

AD-A114 846

NATIONAL AERONAUTICAL ESTABLISHMENT OTTAWA (ONTARIO) F/G 2/6  
BRIEF OUTLINE OF AN AERIAL PLANTING CONCEPT FOR FORESTRY APPLIC--ETC(U)  
OCT 81 A D WOOD

UNCLASSIFIED

NAE-LR-607

NRC-19782

NL



END  
DATE  
FILMED  
6 82  
DTIC

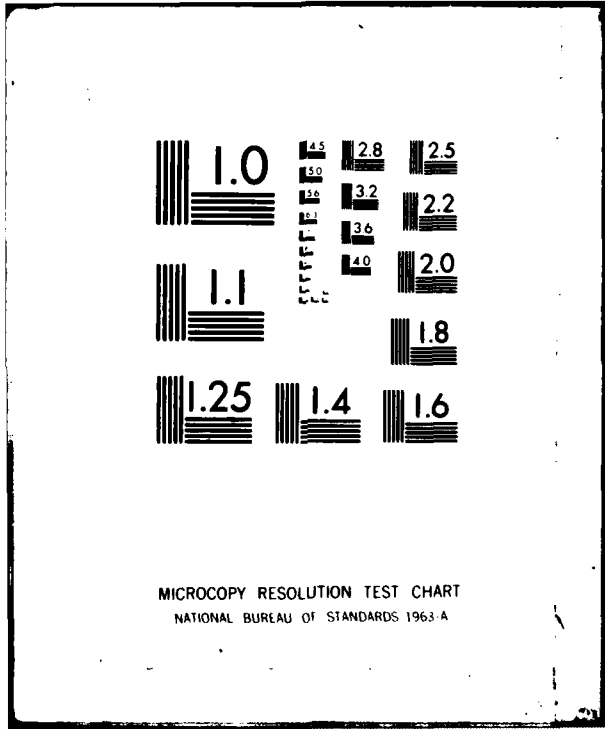

MICROCOPY RESOLUTION TEST CHART  
NATIONAL BUREAU OF STANDARDS 1963-A

AD A114846



National Research  
Council Canada

Conseil national  
de recherches Canada

1

# BRIEF OUTLINE OF AN AERIAL PLANTING CONCEPT FOR FORESTRY APPLICATIONS

by

A. D. Wood

National Aeronautical Establishment

OTTAWA

OCTOBER 1981

DTIC  
ELECTE  
MAY 25 1982  
S D

B

**DISTRIBUTION STATEMENT A**  
Approved for public release  
Distribution Unlimited

AERONAUTICAL REPORT

LR-807

NRC NO. 19782

Canada

82 05 25 155

**BRIEF OUTLINE OF AN  
AERIAL PLANTING CONCEPT FOR FORESTRY APPLICATIONS**

**BREF EXAMEN DU  
PRINCIPE DE PLANTATION PAR VOIE AÉRIENNE APPLIQUÉ À LA FORESTERIE**

**by/par**

**A.D. Wood**

**A.D. Wood, Head/Chef  
Flight Research Laboratory/  
Laboratoire des recherches en vol**

**G.M. Lindberg  
Director/Directeur**

**ABSTRACT**

↙ An aerial planting concept for forestry applications is briefly described and examples are given of the results obtained during biological and flight experiments with a prototype system. In this system newly-developed, seed-containing planting darts are sequentially ejected from several dispensers installed on a light helicopter, which is also fitted with high-accuracy, short-range, navigational-guidance equipment. Continuing development entails further testing in the field and a more detailed examination of manufacturing aspects. ↗

**RÉSUMÉ**

Description sommaire du principe de plantation par voie aérienne, appliqué à la foresterie. Exemples de résultats obtenus lors d'expériences biologiques et de vols expérimentaux avec un système prototype. Ce nouveau système fait appel à l'éjection, à intervalles programmés, de flèches contenant des graines, à partir de plusieurs distributeurs installés sur un hélicoptère léger qui est également doté d'instruments de guidage et de navigation de courte portée, mais de haute précision. Le perfectionnement du système exige plus d'essais sur le terrain et un examen plus détaillé des aspects relatifs à la fabrication.



(ii)

Accession For	
NTIS GRA&I	<input checked="" type="checkbox"/>
DTIC TAB	<input type="checkbox"/>
Unannounced	<input type="checkbox"/>
Justification	
<b>PER LETTER</b>	
By	
Distribution/	
Availability Codes	
Dist	Avail and/or Special
<b>A</b>	

## CONTENTS

	Page
ABSTRACT .....	(ii)
INTRODUCTION .....	1
PLANTING-DART DESIGN .....	1
SYSTEM CONCEPT .....	2
DEVELOPMENT AND TESTING .....	5
OPERATIONAL UTILIZATION .....	10
ACKNOWLEDGEMENTS .....	10
REFERENCES .....	10

## ILLUSTRATIONS

Figure		Page
1	Aerial Planting-Dart Characteristics .....	2
2	Schematic View of Light Helicopter Equipped With Four Dispensers .....	3
3	Test Helicopter With Two Prototype Dispensers .....	3
4	Aerial Reforestation Support Requirements .....	4
5	Representative Specimens of Three Species Used in Greenhouse Tests of Darts. Douglas Fir, Black Spruce and Jack Pine After 100 Days .....	5
6	Dart With Jack Pine Seedlings in April 1981 After Over-Wintering at Petawawa .....	6
7	Penetration of Two Darts Dropped at Petawawa. Soil Cut Away to Show Detail .....	6
8	Dart Impact Pattern for Part of Three Tracks Flown at 300 Ft. Using Single Prototype Dispenser and Navigational Guidance .....	7
9	Vertical Photograph Showing Darts Ejected From Port and Starboard Dispensers During Flight Drop Tests at Ottawa .....	8
10	Iron Bridge Field Trials. Examples of Darts Shortly After Impact .....	9
11	Iron Bridge Field Trials. Examples of Darts With Fins Unsealed Following Exposure to Overnight Showers .....	9

## BRIEF OUTLINE OF AN AERIAL PLANTING CONCEPT FOR FORESTRY APPLICATIONS

### INTRODUCTION

With approximately 60 million acres of cut-over or burned forest land in Canada inadequately stocked and another half-million acres being added to this total every year, there is growing recognition that mechanized re-planting, as one aspect of improved forest management, is urgently needed to reverse this trend (Refs. 1 and 2). In parallel with efforts being made elsewhere in Canada to develop mechanized planting techniques utilizing surface vehicles, the Flight Research Laboratory undertook to investigate the possibility of developing an aerial planting system. This project, originated in 1976 at the instigation of the Forest Management Institute of Environment Canada, has now reached the stage where limited field trials of a prototype system are being planned and implemented.

There is a difference between aerial planting and aerial seeding. The latter technique is not new and is in operational use in several countries, including Canada, in specific areas where its special advantages and limitations are appropriate. Seeds are either scattered in a broadcast fashion or are pelletized in clay and ejected sequentially from dispensers carried by a low-flying aircraft. Seeds or pellets released in this way do not penetrate the ground surface and are therefore subject to a high rate of attrition, which may be reduced to acceptable levels by taking suitable measures to prepare the site as a seed-bed (Refs. 3, 4 and 5).

In contrast, the aerial planting concept described here requires seeds and a quantity of selected growth medium to be containerized within small darts which, on release from the aircraft, are intended to penetrate the ground surface. The broad purpose is to improve, by a large factor, the prospect for germination and subsequent growth by providing an immediately favourable environment within the dart and, as a result of ground penetration, early access to underlying mineral soil by the developing roots. A capability for establishing a favourable pathway through growth-inhibiting surface debris could greatly reduce or conceivably, in some circumstances, eliminate the need for site preparation, leading, for example, to potential applications in re-generating forest areas recently destroyed by fire or in rapid re-planting after logging.

While the planting dart is the key element in the system which has been under development, it would be of no practical value in the absence of an effective method for releasing large numbers of darts in such a way as to achieve a satisfactory and predictable distribution on the ground. Furthermore, the dart impact patterns resulting from successive sorties should be contiguous so that an even distribution is obtainable over large areas. Planting dart design and testing has therefore proceeded in parallel with accompanying measures to provide compatible dispensing and aircraft guidance equipment.

This outline is intended as the fore-runner of a more comprehensive report on the development of the aerial planting system.

### PLANTING-DART DESIGN

The numerous functions to be performed and requirements to be met by the planting-dart from the time of manufacture until it has served its purpose in establishing a new seedling on site have entailed many compromises leading to the present design.\* A low unit cost potentiality has been a primary consideration, since preliminary estimates of system operating costs showed this to be the most significant factor in achieving economic viability. The dart consists of a combination of paper and plastic components. The paper container is basically a cropped cone or pyramid formed from a

---

\* Patents pending

flat blank and subsequently folded in such a way as to acquire fin surfaces which also provide closure for the container at their trailing edges. A ballast-plug, matching the internal shape of the forward part of the container, and a corresponding external nose-cap lock together, clamping the paper component and forming an integrated dart assembly as illustrated in Figure 1. The seed and growth material are accommodated in the cavity available aft of the ballast-plug and forward of the fins. This planting-dart configuration lends itself to meeting the essential criteria of aerodynamic stability, low drag and ability to penetrate on impact with the ground. It is also amenable to filling with growth medium and seed, since this can be done prior to the final operation of folding to establish the fins and sealing with water-soluble adhesive.

Other criteria governing the design include sufficient ruggedness to withstand handling and impact loads, good reproducibility in production quantities, automatic unsealing of the fins during rainfall after planting, rapid paper deterioration after planting to facilitate root egress and the absence of features which impede subsequent seedling development.

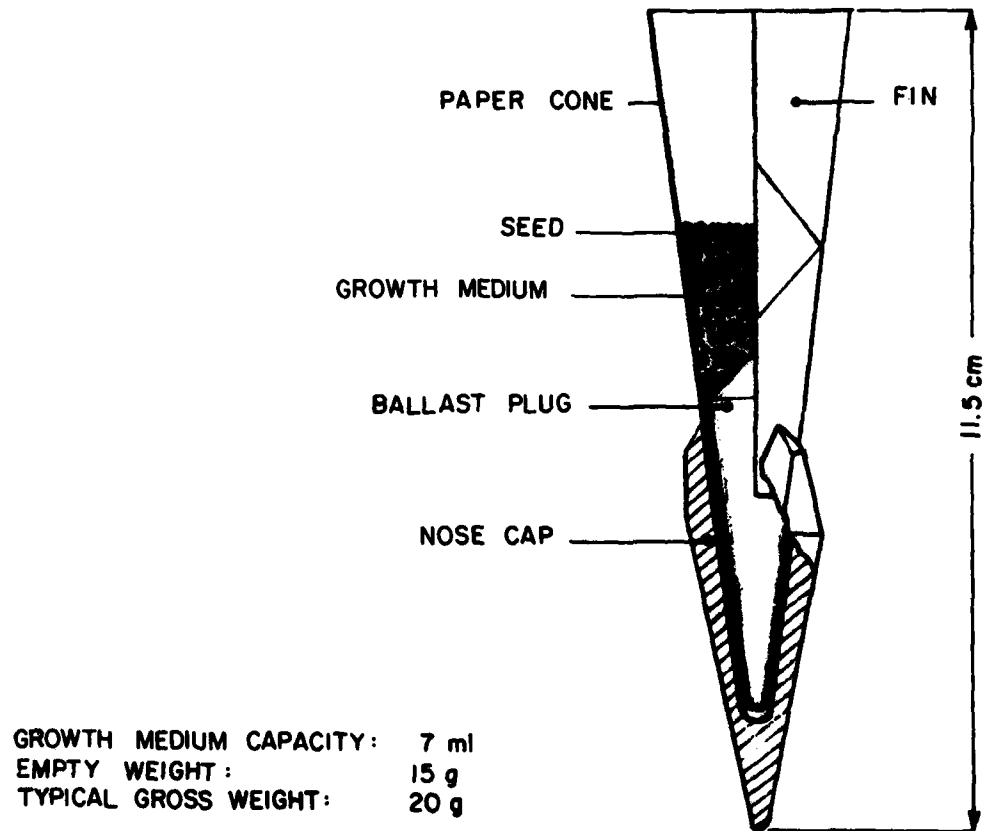
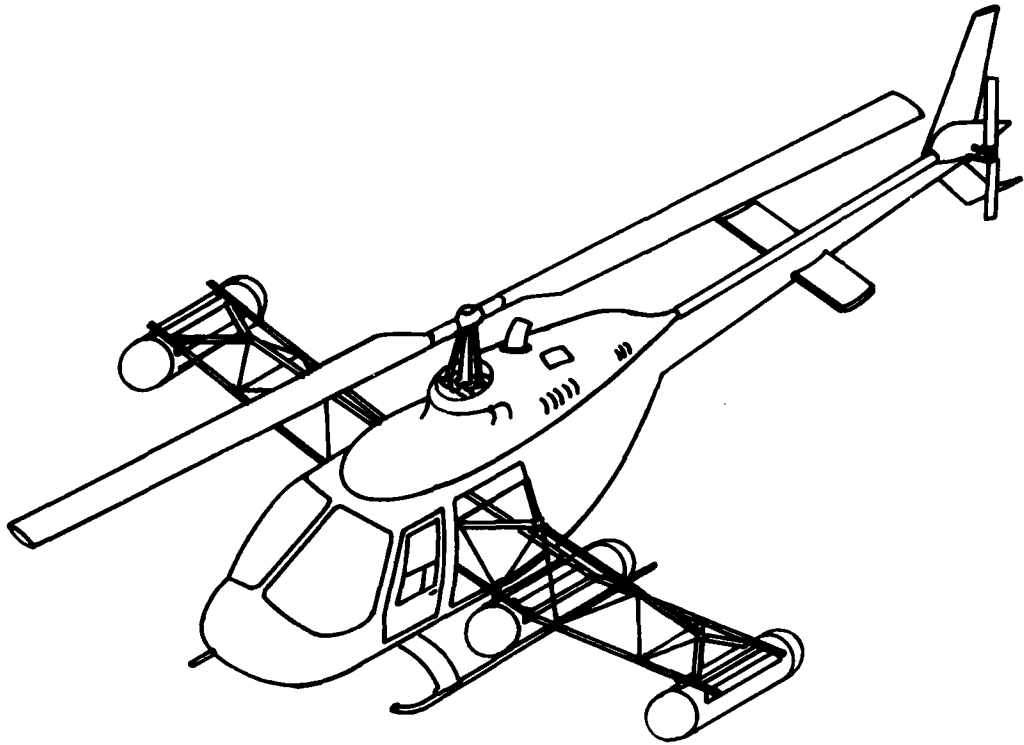

FIG. 1: AERIAL PLANTING-DART CHARACTERISTICS

#### SYSTEM CONCEPT

Forest stand densities in Canada vary considerably with tree species and region. For densities typically in the range 600 to 1200 stems per acre the average spacing between trees is from six to 10 ft. The task of the delivery system, therefore, is to lay down a carpet of darts with this average spacing or some equivalent spacing which allows for anticipated attrition from various causes.



**FIG. 2: SCHEMATIC VIEW OF LIGHT HELICOPTER EQUIPPED WITH FOUR DISPENSERS**

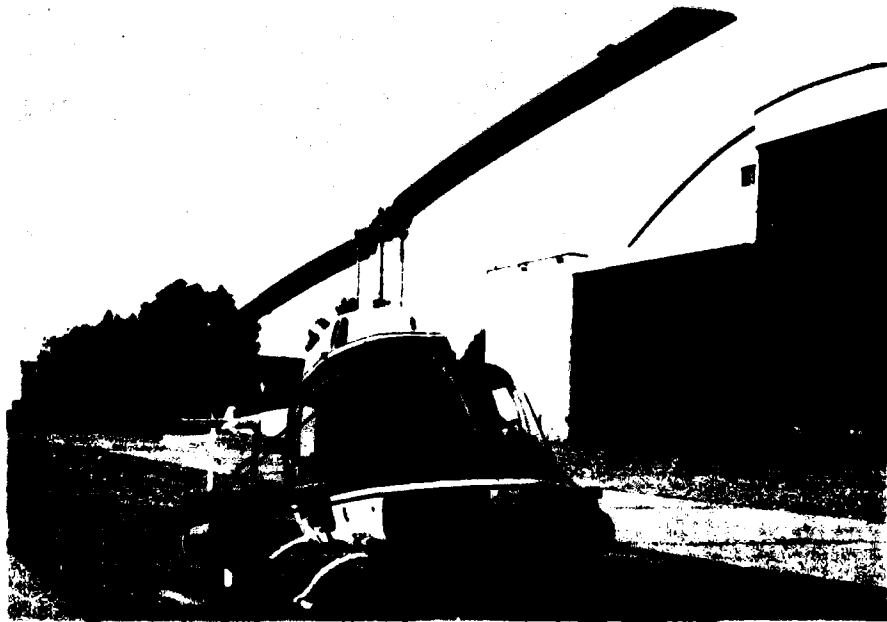

**FIG. 3: TEST HELICOPTER WITH TWO PROTOTYPE DISPENSERS**

To carry out this task a light helicopter equipped with a high-accuracy, short-range, micro-wave navigational guidance system was considered to be the most suitable vehicle, at least in the early stages of development of the aerial planting technique. A schematic view of such a helicopter with four equally-spaced dart dispensers transversely mounted is shown in Figure 2. A photograph of the test helicopter equipped with two dispensers is shown in Figure 3. Each dispenser\* has a 400-dart capacity and has been designed to eject darts sequentially at equal intervals at rates up to 10 darts per second. A principal feature is the re-chargeable magazine, the object being to expedite turn-around between planting sorties by the rapid replacement of magazines. In addition the removable magazines provide a convenient means for storing and transporting planting-darts following manufacture.

Figure 4 illustrates the support requirements associated with a hypothetical aerial reforestation operation. The helicopter is located as close as possible to the area to be planted in order to minimize transit time between planting sorties. Micro-wave transponders are set up to give line-of-sight coverage of the designated area with intersections between position lines preferably close to being orthogonal. An adequate supply of charged magazines is kept at the helicopter loading station and replenished by truck transport or other appropriate means, empty magazines being returned to the manufacturing facility for re-charging with planting-darts.

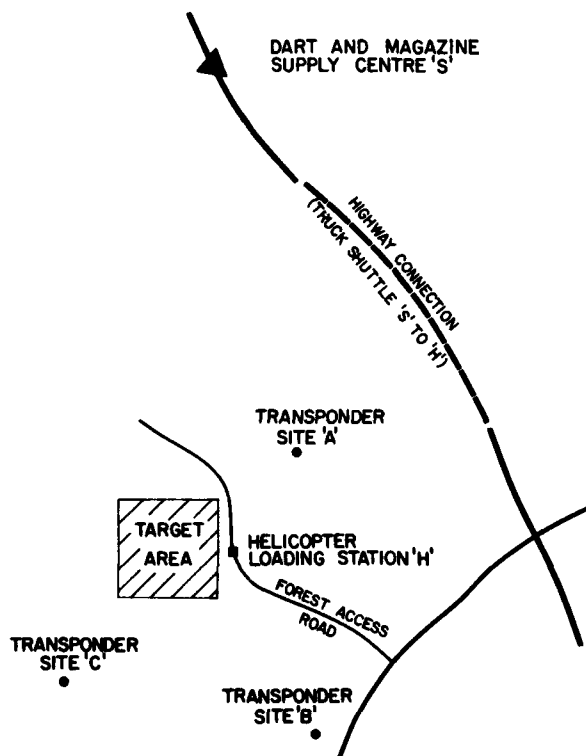

FIG. 4: AERIAL REFORESTATION SUPPORT REQUIREMENTS

Assuming, for the sake of example, an intended average dart spacing of 6.5 ft., the number of darts planted per acre amounts to 1030. Thus the helicopter with a full load would plant 1.55 acres with 1600 darts on each sortie and would require 413 sorties to plant one square mile with 660,800 darts. With the loading station close to or within the area designated for planting, sortie cycle times comparable with those characteristic of operations such as aerial fertilizing are plausible. Using a sortie cycle time of five min., the total time required to plant one square mile is 34.4 hours, possibly a one-week task for one helicopter, given suitable weather.

\* Patents pending

## DEVELOPMENT AND TESTING

The inter-disciplinary nature of this project has necessitated a close integration of biological and engineering considerations. The choice of paper and plastic materials, particularly in achieving a combination of bio-degradability and adequate weight while avoiding toxicity, the evolution of plug and nose-cap shapes to promote favourable root configurations, the composition and quantity of growth medium, the effects of exterior soil characteristics, depth of dart penetration and fin opening after unsealing and the influence of various watering schedules have all been the subject of biological testing. Several seed species have been used and in some cases greenhouse tests, carried out under contract at the University of Toronto, have been supplemented by similar field plantings at the Petawawa National Forestry Institute.

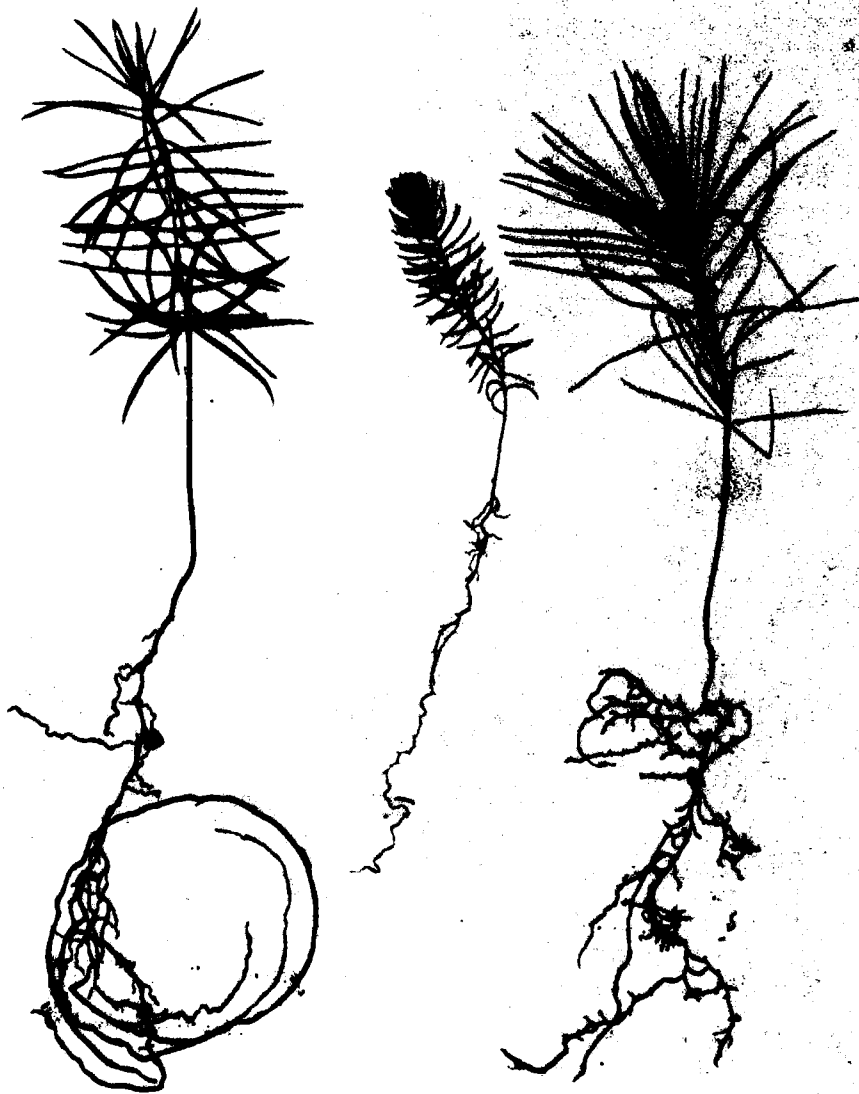

**FIG. 5: REPRESENTATIVE SPECIMENS OF THREE SPECIES USED IN GREENHOUSE TESTS OF DARTS. DOUGLAS FIR, BLACK SPRUCE AND JACK PINE AFTER 100 DAYS.**

Figure 5 shows specimens of three species removed from greenhouse-planted darts after 100 days. Figure 6 shows Jack Pine seedlings after over-wintering in one of the darts planted in 1980 at Petawawa. The potential of the planting-dart in establishing a vigorous seedling with good root and foliage development is illustrated by these examples.



**FIG. 6: DART WITH JACK PINE SEEDLINGS IN APRIL 1981  
AFTER OVER-WINTERING AT PETAWAWA**



**FIG. 7: PENETRATION OF TWO DARTS DROPPED AT PETAWAWA.  
SOIL CUT AWAY TO SHOW DETAIL.**

Early flight experiments indicated that to penetrate a compact soil from a convenient altitude above ground of, say, 300 ft. a dart would need to weigh about 20 g. Impact velocities as high as 160 ft. per sec. were measured directly using a high-speed camera technique. Penetration may be adjusted, however, to suit a particular terrain and soil by pre-selecting a suitable dart weight through, for example, the choice of plastic material and by varying the flight altitude above ground. Figure 7 illustrates the penetration of darts dropped into a humus-covered, loamy sand at Petawawa. Soil has been cut away to show the nose-cap and the paper cone, which remained intact even with excessive penetration.

Testing of the dispenser design and of the navigational guidance system used to establish accurate flight tracks was conducted at Ottawa using permanently-sealed dummy darts ballistically and aerodynamically similar to those intended for planting. The measured dart ejection rate of the present dispenser is eight darts per sec., to be increased to the design figure of 10 darts per sec. with continuing development. An on-board computer in the commercially-available navigational guidance system converts positional information into steering signals with respect to a selectable series of parallel tracks. Cross-track errors and along-track position are presented to the pilot, so that the capability exists for matching the dart patterns from successive sorties without unacceptable overlapping or gaps. Flight tests are being made to determine the accuracy with which it is possible to fly tracks with this system, which has a capability for measuring distance to within  $\pm 10$  ft.

Flight drop tests have also been made using the navigational guidance system and with either one or two dispensers ejecting darts. Figure 8, transcribed from aerial photographs, shows the dart impact pattern for part of three parallel tracks flown at 300 ft. with one dispenser in operation. Figure 9 is a photograph taken with the same 70 mm vertically-mounted camera during the course of a similar flight drop test with two dispensers in operation. In this photograph darts ejected from both the port and starboard dispensers are visible for some distance below the helicopter. White and coloured tiles used to mark dart impact positions in previous drops and to provide photogrammetric references are also visible.

In June 1981, with the cooperation of the Great Lakes Forest Research Centre of Environment Canada and the Ontario Ministry of Natural Resources, a field trial of the prototype system was conducted near Iron Bridge, 50 miles East of Sault Ste. Marie. A small part of a cleared area which had been windrowed for use as a seed orchard was assigned to the project for this trial. Two transponders were set up on high ground within five miles of the site. Drops from a single dispenser were made along several tracks on two successive days for a total of approximately 700 darts.

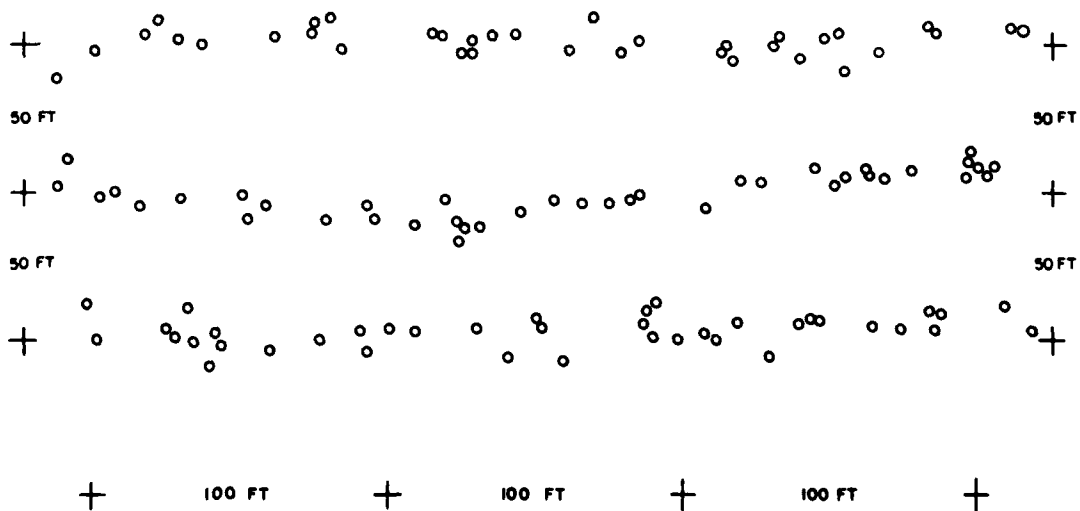

**FIG. 8: DART IMPACT PATTERN FOR PART OF THREE TRACKS FLOWN AT 300 FT. USING SINGLE PROTOTYPE DISPENSER AND NAVIGATIONAL GUIDANCE**

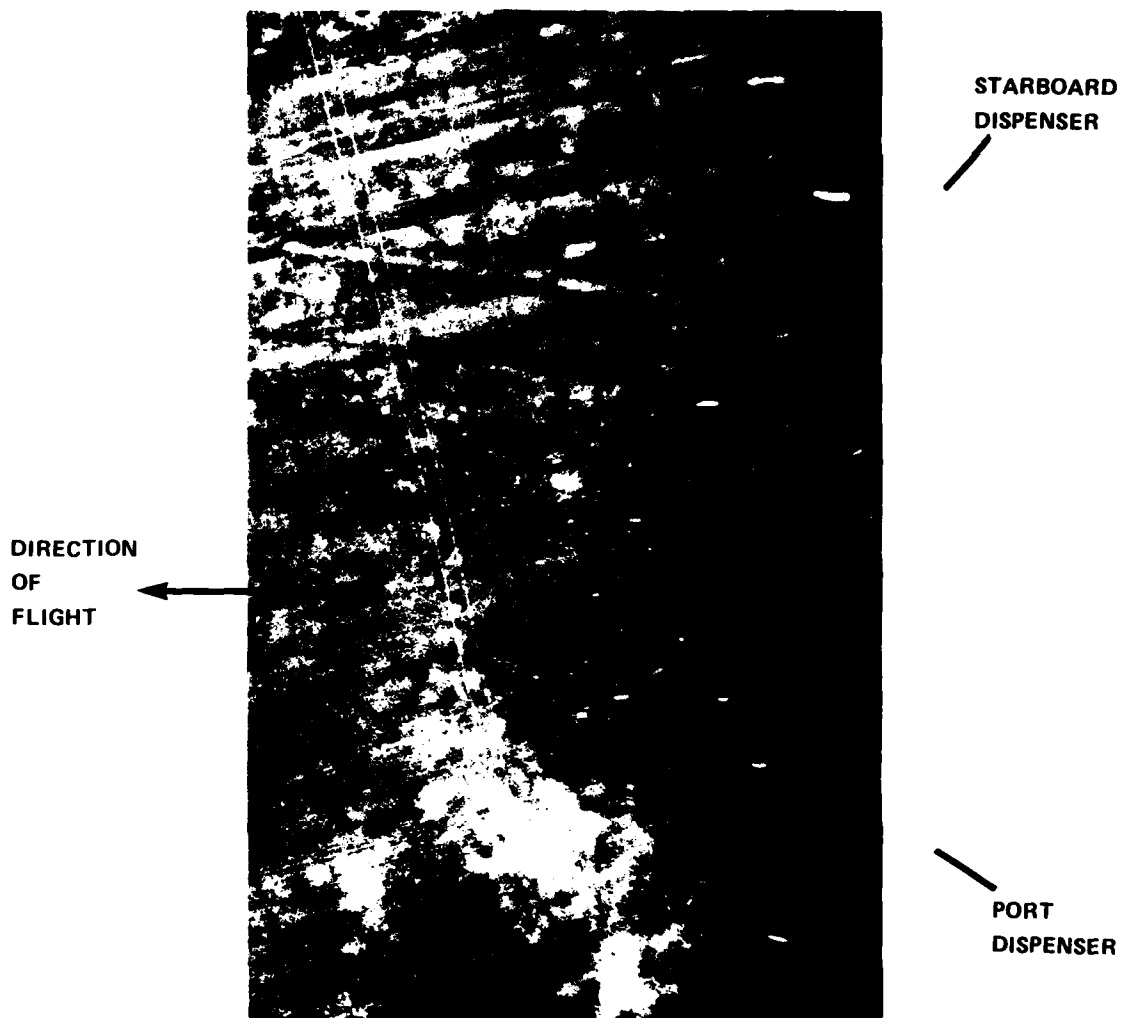

**FIG. 9: VERTICAL PHOTOGRAPH SHOWING DARTS EJECTED FROM PORT AND STARBOARD DISPENSERS DURING FLIGHT DROP TESTS AT OTTAWA**

Figure 10 shows two examples of darts photographed on June 11 shortly after impact. The tiles appearing in the photographs were again used to mark impact positions. Figure 11 shows two further examples of darts dropped on June 11 but photographed on June 12. Overnight showers unsealed the fins of darts dropped on June 11 and they can be seen fully open the following morning, illustrating this aspect of the concept.

This trial provided valuable first experience of prototype system operation and testing in the field, particularly with respect to navigational guidance and dispenser system operations. Locating and marking darts for positional determination by aerial photography was difficult, as anticipated, whenever surface litter or undergrowth provided concealment; a problem less of operational than of experimental significance. Useful subsequent biological monitoring of this particular trial was unfortunately severely compromised by a period of dry weather which prevailed after the operation and by the use of a dry, nutrient-deficient growth medium in the darts, poorly suited to the light, sandy soil found at the site. Future trials of this type would be better carried out earlier in the spring, or possibly just before winter, using a growth medium more closely optimized with respect to the anticipated site characteristics and season.



(a)



(b)

**FIG. 10: IRON BRIDGE FIELD TRIALS. EXAMPLES OF DARTS SHORTLY AFTER IMPACT.**



(a)



(b)

**FIG. 11: IRON BRIDGE FIELD TRIALS. EXAMPLES OF DARTS WITH FINS UNSEALED FOLLOWING EXPOSURE TO OVERNIGHT SHOWERS.**

Since the economic viability of aerial planting as a reforestation technique will greatly depend upon prospective costs as well as upon success in establishing thriving seedlings, early attention has been given to critical production aspects. The supply of paper cones at low cost is known to be feasible. Plastic components in the heavy material required are obtainable using commercial injection-moulding facilities. Costs are reducible by introducing multi-cavity moulds as the quantities required increase. Mechanized assembly, filling, sealing and storage (in magazines) bears some resemblance to the production of other manufactured goods such as shot-shells, pyrotechnics or, for that matter, containerized seedlings now grown in large numbers in nurseries. The costs associated with mechanized assembly and subsequent processes are as yet uncertain, however, pending further investigation.

At the present stage in development an ultimate unit cost per dart of under ten cents when produced in very large numbers (many millions) does not appear unattainable. Utilized in an

operational scenario of the kind already described, the total cost per dart planted may not need to exceed 15 cents. Given an adequate success rate, the cost per established seedling then falls within the range applicable to planting by other methods in many reforestation situations. Economic viability is not, therefore, an unrealistic target.

#### OPERATIONAL UTILIZATION

In considering a concept of aerial reforestation, the Flight Research Laboratory, with assistance from others, has sought to establish feasibility by inter-disciplinary experimental validation of the essential elements. Further field trials of these elements and of the prototype system as a whole are now practical and should be conducted in selected areas. Progress towards more extensive operational utilization of the aerial planting technique necessitates some further examination of dart manufacturing processes and equipment requirements. The results of on-going field trials and manufacturing studies, together with the work already carried out by the Laboratory, should then constitute an adequate foundation for decisions concerning employment of the aerial planting technique on an operational scale.

#### ACKNOWLEDGEMENTS

Mr. C.R. Silversides of the Canadian Forestry Service, Environment Canada, was instrumental in initiating this project and has given valuable encouragement throughout, as has Dr. D.F.W. Pollard, also of CFS, who carried out some preliminary germination and growth experiments. Dr. J.L. Farrar of A.D. Revill Associates and the University of Toronto has provided expert assistance with subsequent systematic biological testing.

#### REFERENCES

1. Reed, F.L.C. and Associates Ltd. *Forest Management in Canada, Vol. 1.*  
Forest Management Institute Information Report  
FMR-X-102, January 1978.
2. Walters, J.  
Silversides, C.R. *Injection Planting of Containerized Tree Seedlings.*  
Forest Management Institute Information Report  
FMR-X-120, February 1979.
3. Griffin, R.H.  
Carr, B.W. *Aerial Seeding of Spruce in Maine.*  
Direct Seeding Symposium, Timmins, Ontario: Canadian  
Forestry Service Publication 1339, September 1973.
4. Riley, L.F. *The Effect of Seeding Rate and Seedbed Availability on  
Jack Pine Stocking and Density in North-Eastern Ontario.*  
Canadian Forestry Service Report O-X-318, August 1980.
5. Mann, W.F., Jr.  
Campbell, T.E.  
Chappell, T.W. *Status of Aerial Row Seeding.*  
Forest Farmer, November/December 1974.

DATE  
FILME  
— 88