

AD-A114 908

DAVID W TAYLOR NAVAL SHIP RESEARCH AND DEVELOPMENT CE--ETC F/6 17/2
POSEIDON BUOY ROLL CONTROL EVALUATION. (U)
JAN 82 C A HOLBERGER

UNCLASSIFIED

DTNRDC/SPD-1027-01

NL

101
200 4

17

END

DATE

FILED

6-82

DTIC

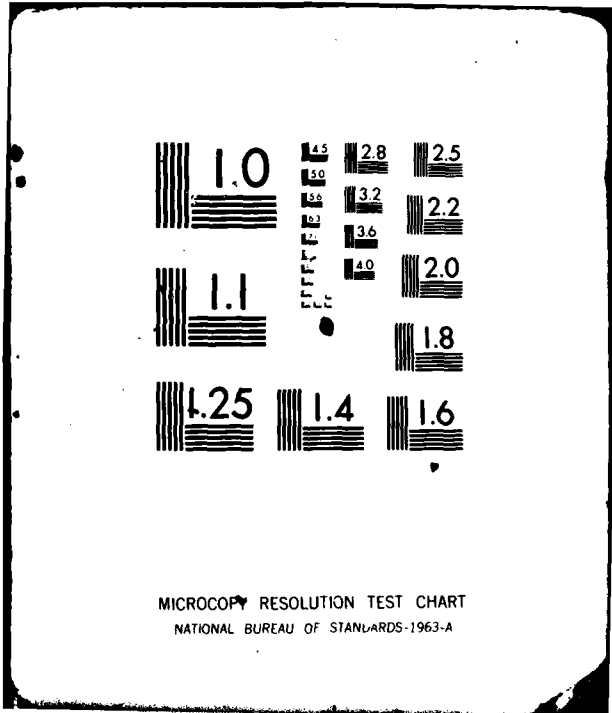

MICROCOPY RESOLUTION TEST CHART
NATIONAL BUREAU OF STANDARDS-1963-A

12

DTNSRDC/SPD 1027-01

DAVID W. TAYLOR NAVAL SHIP RESEARCH AND DEVELOPMENT CENTER



Bethesda, Maryland 20084

AD A 114908

POSEIDON BUOY ROLL
CONTROL EVALUATION

by

C. A. Holberger

APPROVED FOR PUBLIC RELEASE: DISTRIBUTION UNLIMITED

SHIP PERFORMANCE DEPARTMENT
DEPARTMENTAL REPORT

S DTIC
ELECTE
MAY 27 1982
D
E

January 1982

DTNSRDC/SPD 1027-01

DTIC FILE COPY

POSEIDON BUOY ROLL CONTROL EVALUATION

82 05 27 098

MAJOR DTNSRDC ORGANIZATIONAL COMPONENTS

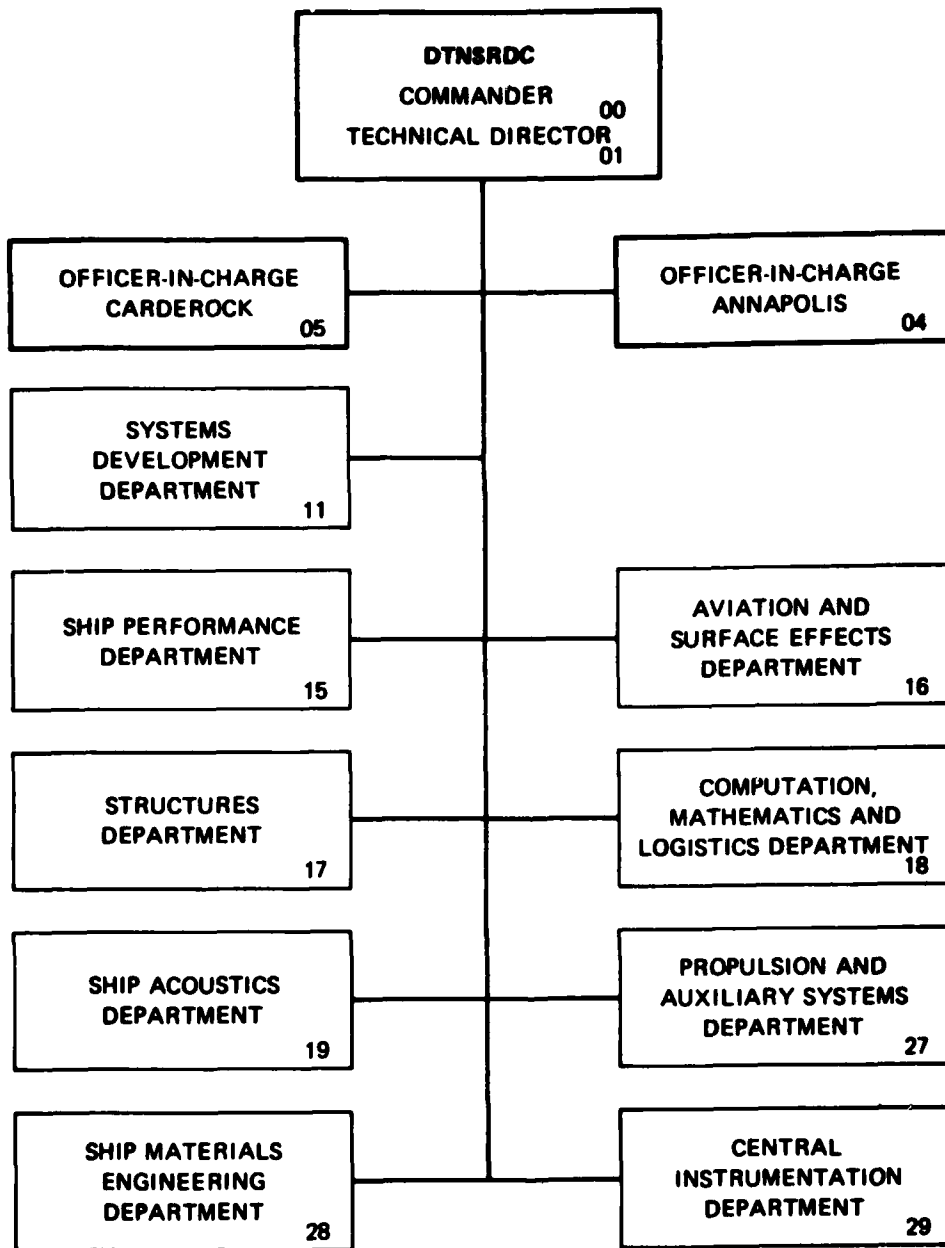

UNCLASSIFIED

SECURITY CLASSIFICATION OF THIS PAGE (When Data Entered)

REPORT DOCUMENTATION PAGE		READ INSTRUCTIONS BEFORE COMPLETING FORM
1. REPORT NUMBER DTNSRDC/SPD 1027-01	2. GOVT ACCESSION NO. AD-A114908	3. RECIPIENT'S CATALOG NUMBER
4. TITLE (and Subtitle) POSEIDON BUOY ROLL CONTROL EVALUATION		5. TYPE OF REPORT & PERIOD COVERED Departmental
		6. PERFORMING ORG. REPORT NUMBER DTNSRDC/SPD 1027-01
7. AUTHOR(s) C. A. Holberger		8. CONTRACT OR GRANT NUMBER(s)
9. PERFORMING ORGANIZATION NAME AND ADDRESS David Taylor Naval Ship R&D Center Ship Performance Department Bethesda, Maryland 20084		10. PROGRAM ELEMENT, PROJECT, TASK AREA & WORK UNIT NUMBERS ELEMENT 64502N TASK AREA X0742300 DTNSRDC W.U. 1541-406
11. CONTROLLING OFFICE NAME AND ADDRESS Naval Electronic Systems Command Washington, D. C. 20363		12. REPORT DATE January 1982
		13. NUMBER OF PAGES 18
14. MONITORING AGENCY NAME & ADDRESS (if different from Controlling Office)		15. SECURITY CLASS. (of this report) UNCLASSIFIED
		15a. DECLASSIFICATION/DOWNGRADING SCHEDULE
16. DISTRIBUTION STATEMENT (of this Report) APPROVED FOR PUBLIC RELEASE: DISTRIBUTION UNLIMITED		
17. DISTRIBUTION STATEMENT (of the abstract entered in Block 20, if different from Report)		
18. SUPPLEMENTARY NOTES		
19. KEY WORDS (Continue on reverse side if necessary and identify by block number) Communications buoys Roll control Antenna system dynamics		
20. ABSTRACT (Continue on reverse side if necessary and identify by block number) The POSEIDON Buoy roll control mechanism was evaluated to determine the best configuration of gain, pendulum moment, rudder span, and chord length. The results indicate that a 3 to 1 gain; a 34-in. lb (3.84-Nm) pendulum moment; a 4.5-in. (11.4-cm) rudder span; and a 2.81-in. (7.14-cm) chord length providing a 31.2 percent pivot point, with reference to the leading edge of the flap, yields a combination that minimizes roll.		

DD FORM 1473
1 JAN 73

EDITION OF 1 NOV 65 IS OBSOLETE
S/N 0102-014-6601

UNCLASSIFIED
SECURITY CLASSIFICATION OF THIS PAGE (When Data Entered)

UNCLASSIFIED

SECURITY CLASSIFICATION OF THIS PAGE(When Data Entered)

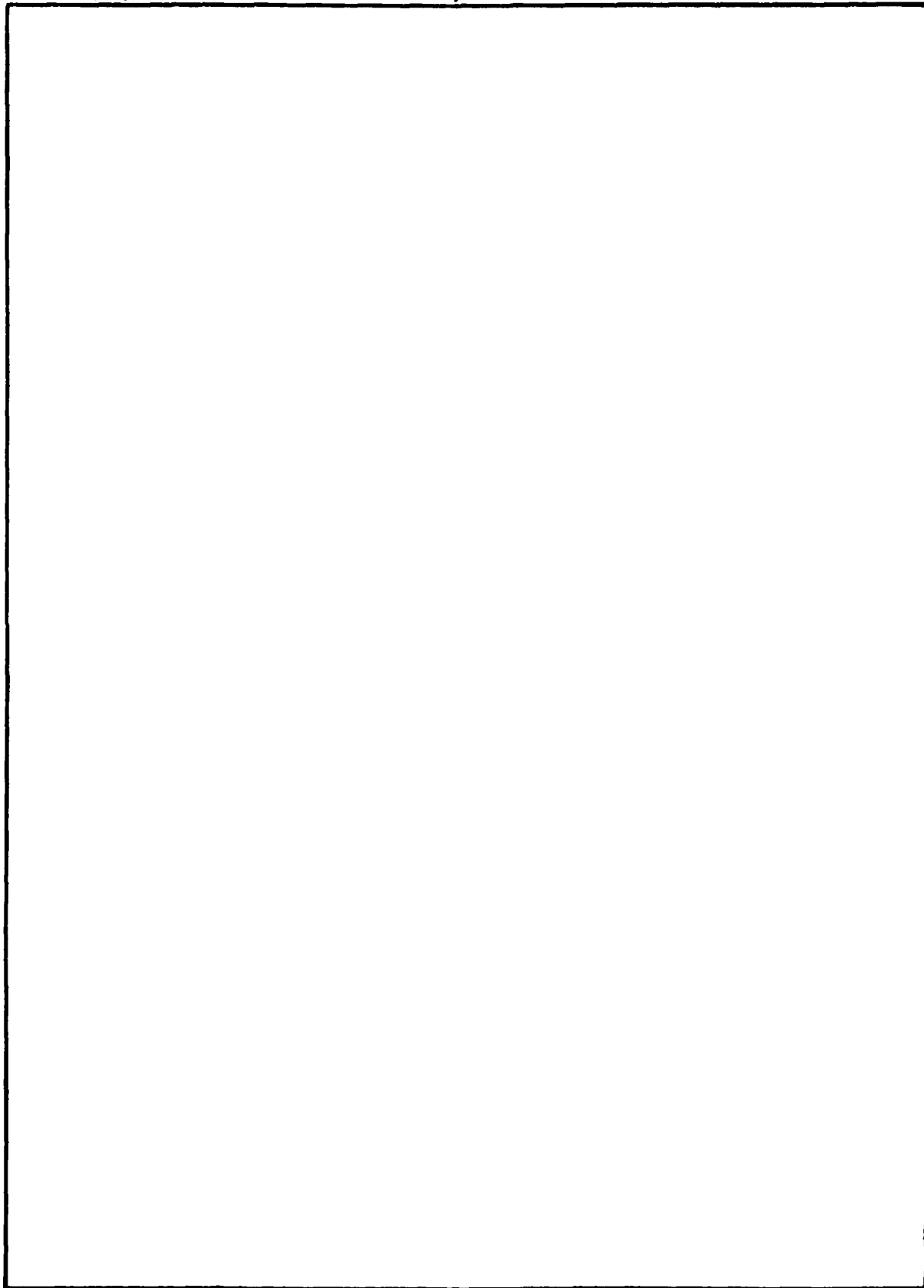

UNCLASSIFIED

SECURITY CLASSIFICATION OF THIS PAGE(When Data Entered)

TABLE OF CONTENTS

	Page
LIST OF FIGURES	iii
LIST OF TABLES	iv
ABSTRACT	1
ADMINISTRATIVE INFORMATION	1
INTRODUCTION	1
EXPERIMENTAL APPARATUS AND INSTRUMENTATION	2
PROCEDURES	2
RESULTS	11
CONCLUSIONS	16
RECOMMENDATIONS	16

LIST OF FIGURES

1 - General Towing Arrangement in the Deep-Water Basin	3
2 - Roll Control Mechanism of Aft End of POSEIDON Buoy	5
3 - Schematic of Roll Control Mechanism	7
4 - Buoy Reference Plane and Sign Conventions	10
5 - Roll Angle as a Function of the Number of Wedges for Various Gain Values	14
6 - Roll Angle and Rudder Deflection as a Function of Speed for Various Chord Lengths	15

Accession For	
NTIS GRA&I	<input checked="" type="checkbox"/>
DTIC TAB	<input type="checkbox"/>
Unannounced	<input type="checkbox"/>
Justification	
By _____	
Distribution/	
Availability Codes	
Dist	Avail and/or Special
A	

LIST OF TABLES

	Page
1 - Roll Control Variables	8
2 - Measurement System Transducer Characteristics	9
3 - Roll Control Effectiveness as a Function of Speed for Various Pendulum Moments	12
4 - Roll Control Effectiveness as a Function of Speed for Two Rudder Spans	13

ABSTRACT

The POSEIDON Buoy roll control mechanism was evaluated to determine the best configuration of gain, pendulum moment, rudder span, and chord length. The results indicate that a 3 to 1 gain; a 34-in. lb (3.84-Nm) pendulum moment; a 4.5-in. (11.4-cm) rudder span; and a 2.81-in. (7.14-cm) chord length providing a 31.2 percent pivot point, with reference to the leading edge of the flap, yields a combination that minimizes roll.

ADMINISTRATIVE INFORMATION

The experimental evaluation described in this report was funded by the Naval Electronic System Command Element 64502N, Task Area X0742300, David Taylor Naval Ship Research and Development Center Work Unit 1-1548-406.

INTRODUCTION

The David Taylor Naval Ship Research and Development Center (DTNSRDC) has a continuing effort supporting the submarine towed communications program under the sponsorship of the Naval Electronics Systems Command (NAVELEX PME-110) and the technical management of the Naval Sea Systems Command (NAVSEA 61Y4). Under this program it has been determined that during the construction of submarine communications buoys slight eccentricities are unavoidable. These deviations from symmetry cause the buoy to have an inherent dynamic roll. To compensate for this roll, dynamic trim tests must be conducted in the towing basin on each buoy prior to Fleet use.

The POSEIDON Towed Buoy Antenna which is currently under investigation for application in the AN/BSQ-5 program will have a speed requirement higher than buoy systems have had in the past. This higher speed makes the dynamic trim even more critical.

To reduce the roll induced by buoy asymmetries and ultimately eliminate the requirement for dynamically trimming each buoy, a roll control mechanism was designed, fabricated, and then evaluated in the deep-water basin of DTNSRDC.

Buoy roll and the roll control rudder angles were measured for a series of roll control gains, chord lengths, pendulum moments, and rudder lengths for various buoys asymmetries to determine an optimum configuration. This report describes the mechanism and the experimental procedures. Recommendations for a final configuration are made.

EXPERIMENTAL APPARATUS AND INSTRUMENTATION

The roll control towing evaluations were performed in the deep-water basin of DTNSRDC. The basin is 277-ft (84.6-m) long, 51-ft (16-m) wide, and 22-ft (7-m) deep and is filled with fresh water at about 68°F (20°C). The towing arrangement is shown in Figure 1. A depressor, simulating a submarine, is suspended from the towing carriage. The buoy is connected to the depressor with a 5-ft (1.5-m) length of 0.5-in. (1.27-cm) diameter, double-armored cable.

The roll control mechanism shown in Figures 2 and 3 consists of a simple pendulum connected to the rudder by two pivotal reverse linkage arms. As the buoy rolls port-side down, the pendulum swings to port causing the rudder to deflect to starboard. This action causes a yawing and rolling moment which decreases the buoy's roll angle.

The design of this device allows for five rudder gain settings, two rudder spans, two pendulum moments, and five chord lengths which are obtained by adding tabs of various thickness to the trailing edge of the rudder. These values are shown in Table 1.

The following instrumentation was used in the towing tank evaluation:

1. Two pendulum potentiometers mounted on the buoy keel to measure buoy pitch and roll angles
2. A rotational potentiometer mounted on the roll-control rudder to measure rudder angle
3. A ring-gage dynamometer mounted at the depressor to measure buoy tension
4. A magnetic pick-up on the towing carriage to measure velocity

These parameters were recorded on a six-channel strip-chart recorder. Their ranges and accuracies are listed in Table 2. The buoy reference planes and sign conventions are shown in Figure 4.

PROCEDURES

A series of 15-deg angle wedges 3-in. (7.6-cm) long with a 1.5-in. (3.8-cm) chord were placed on the outside of the vertical stabilizer of the buoy to induce a roll angle. As many as four wedges totaling 12-in. (30.5-cm) on the port stabilizer and two wedges totaling 6-in. (15.2-cm) on the starboard stabilizer were used. These wedge configurations and their dimensions are listed in Table 1.

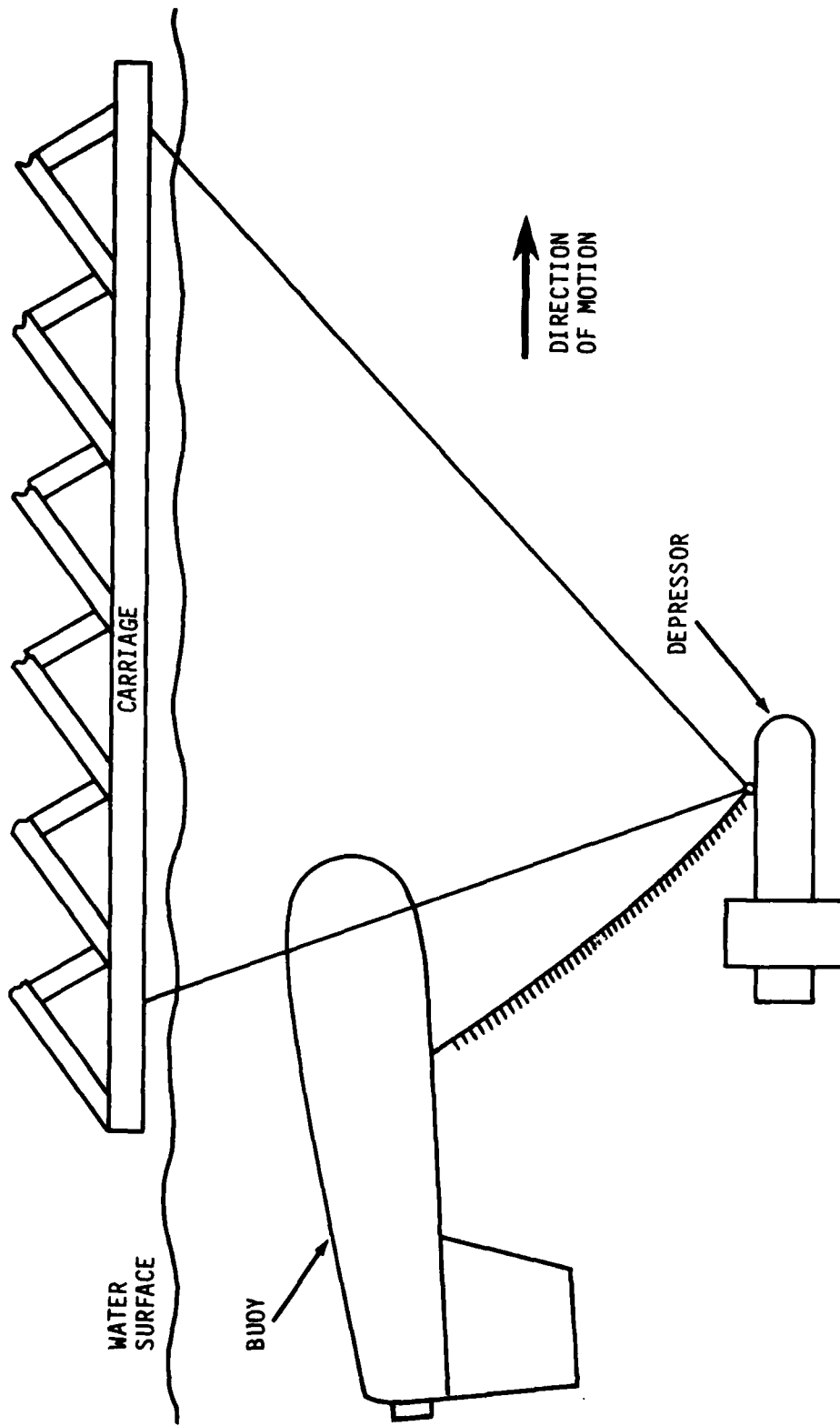

Figure 1 - General Towing Arrangement in the Deep-Water Basin

THIS PAGE INTENTIONALLY LEFT BLANK



PSD 6768-12-81

Figure 2a - Roll Control Mechanism on Aft End of
POSEIDON Buoy, Cover On



PSD 6770-12-81

Figure 2b - Roll Control Mechanism, Cover Off
Figure 2 - Roll Control Mechanism on Aft End of POSEIDON Buoy

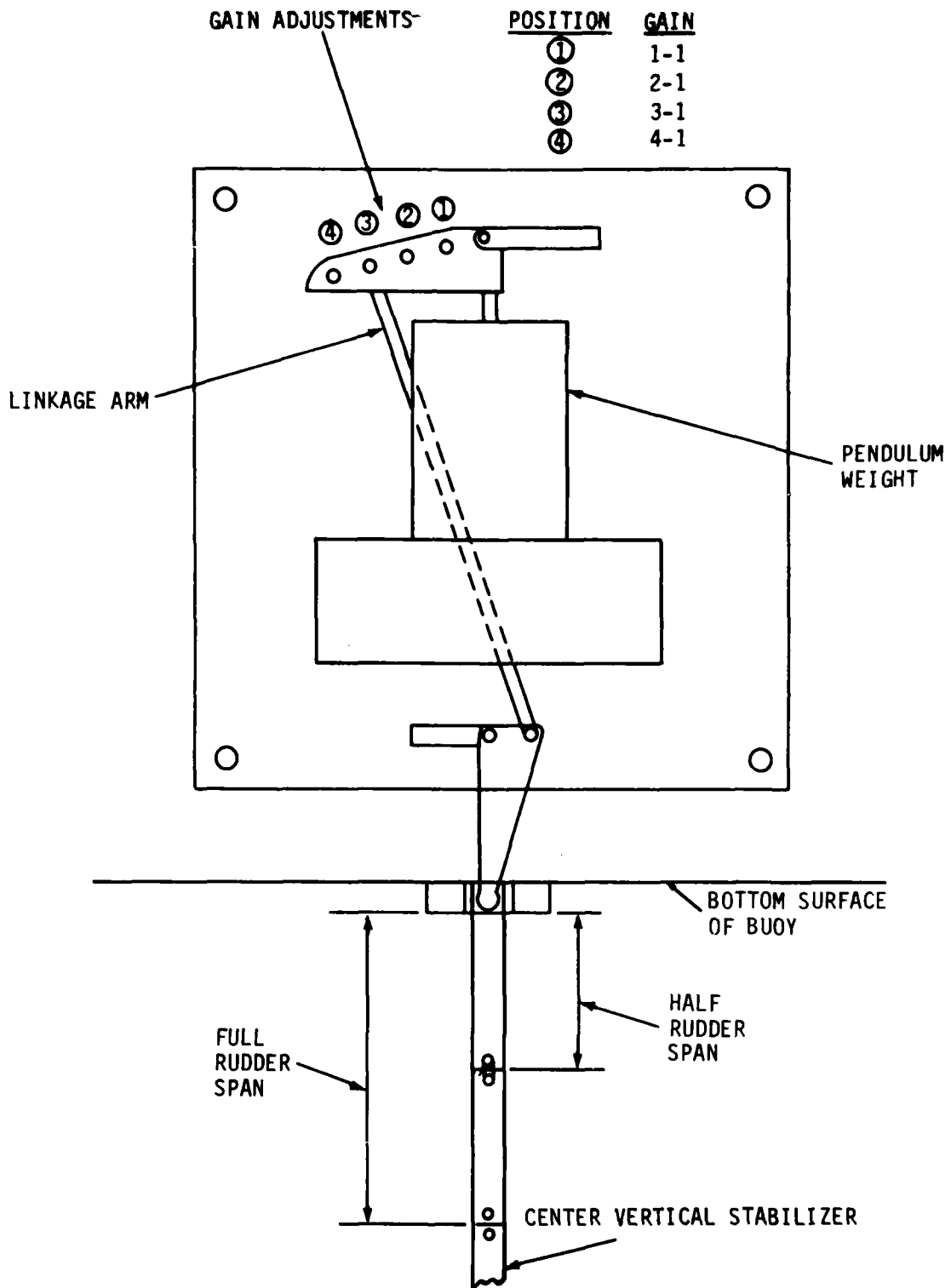

Figure 3 - Schematic of Koll Control Mechanism

TABLE 1 - ROLL CONTROL VARIABLES

Variables	Values of Variables					
Pendulum Moment (in. lb) (Nm)	2.4	3.4				
	2.71	3.84				
Rubber Span (in.) (cm)	4.5	9.0				
	11.43	22.86				
Pendulum Linkage Gain	Fixed	1 to 1	2 to 1	3 to 1	4 to 1	
Rudder Tab No.	-	1	2	3	4	
Chord Length (in.) (cm)	2.75	2.81	2.91	3.0	3.0	
	6.98	7.14	7.39	7.62	7.85	
Pivot Point (percentage)	31.8	31.2	30.1	29.2	28.3	
No. of Wedges and Side	4 PT*	3 PT	2 PT	1 PT	0	1 STB* 2 STB
Total Wedge Length (in.) (cm)	12.0	9.0	6.0	3.0	0	3.0 6.0
	30.5	22.9	15.2	7.6	0	7.6 15.2
* PT = Port Side, STB = Starboard Side						

TABLE 2 - MEASUREMENT SYSTEM TRANSDUCER CHARACTERISTICS

Measurement	Transducer	Range	Accuracy
Roll Angle	Potentiometer	-20 deg to +20 deg	±0.5 deg
Rudder Angle	Potentiometer	14 deg starboard to 20 deg port	±0.5 deg
Speed	Magnetic Pick-up	0-20 knots (0-10.4 m/s)	±0.1 knot (±0.05 m/s)
Buoy Tension	Strain Gage	0-4,000 lb (0-17,800 N)	±20 lb (±89N)
Pitch Angle	Potentiometer	-20 deg to +20 deg	±0.5 deg

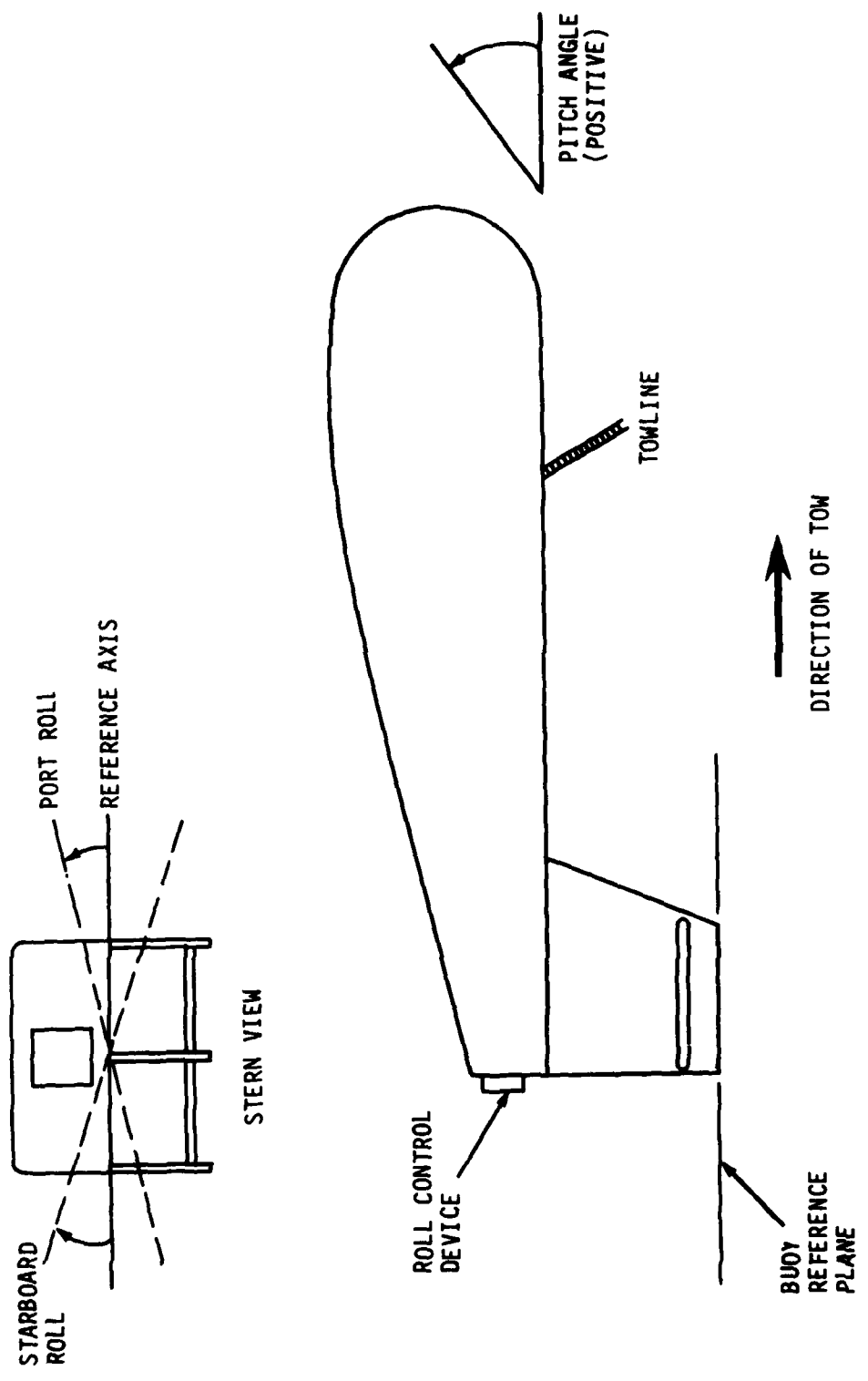

Figure 4 - Buoy Reference Plane and Sign Conventions

The first set of runs were made with the roll control fixed at 0 deg to determine the effect of known asymmetries on the roll angle. The roll angle then was measured for the seven-wedge configurations through a speed range from 6 to 14 knots (3.2 to 7.4 m/s). With the roll control free, the gain, the chord length, the pendulum moment, and the rudder spans were varied one at a time. Using known induced roll angles for specific wedge-speed configurations, the action of the mechanism and its effect on buoy roll were observed to determine the best configuration of the above variables.

RESULTS

Results for this evaluation are divided into four categories: pendulum moment, rudder span, gain setting, and chord length.

Characteristic data comparing the two pendulum moment values evaluated are shown in Table 3. In general, for equal conditions, a greater pendulum moment deflected the rudder more, and the resulting roll was less.

Characteristic data comparing the two rudder spans evaluated are shown in Table 4. The half-rudder of 4.5-in. (11.4-cm) had a greater deflection and reduced roll more than the full 9.0-in. (22.4-cm) rudder.

Buoy roll results as a function of wedge configuration for various gain settings and the standard "fixed" condition are shown in Figure 5. Initial trials using the 1 to 1 setting were not effective at all. From the scatter in the 2 to 1 to 4 to 1 gain data, it is apparent that there is no significant advantage in any of these values.

Roll and rudder angles for four chord lengths are shown in Figure 6. Increasing the chord length effectively moves the center of pressure on the rudder aft. A chord length too short would have the center of pressure forward of the pivot point. This could tend to make the rudder unstable. A chord length too long would move the center of pressure aft of the pivot point. The flow force at this position acts opposite to the roll control action, thereby stabilizing the rudder at an angle smaller than necessary. This analysis holds up generally, as seen in Figure 6. Data supporting the unstable condition are not presented. On a performance basis the optimum chord length can be determined.

Tab No. 3 (3.0-in. (7.62-cm) chord length or 29.2 percent pivotal) provides less rudder deflection and less roll correction than either Tabs No. 2, No. 1, or

TABLE 3 - ROLL CONTROL EFFECTIVENESS AS A FUNCTION OF SPEED FOR VARIOUS PENDULUM MOMENTS

Pendulum Moment in. lb (Nm)	Carriage Speed kt (m/s)	Rudder Angle degrees Starboard	Roll Angle degrees Port	Uncorrected Roll Angle degrees Port
24 (2.71)	6 (3.1)	0.8	1.0	0.
	8 (4.1)	1.2	2.0	1.0
	10 (5.2)	2.0	3.5	2.0
	12 (6.2)	2.5	5.0	5.0
	14 (7.2)	3.0	8.5	10.0
34 (3.84)	6 (3.1)	2.5	1.0	0.
	8 (4.1)	3.2	2.0	1.0
	10 (5.2)	4.0	2.5	2.0
	12 (6.1)	4.0	4.5	5.0
	14 (7.2)	6.0	7.0	10.0
CONDITIONS: Gain: 3 to 1, Tab Nos. 4, 5 Rudder, Wedges Nos. 2, 3, 4 Port				

TABLE 4 - ROLL CONTROL EFFECTIVENESS AS A FUNCTION OF SPEED FOR TWO RUDDER SPANS

Rudder Length in. (cm)	Speed knots (m/s)	Rudder Angle degrees Port	Roll Angle degrees Starboard	Uncorrected Roll Angle degrees Starboard
9.0 (22.9)	6 (3.1)	1.0	2.0	3.0
	8 (4.1)	1.5	3.0	4.3
	10 (5.2)	2.0	3.8	7.2
	12 (6.2)	2.0	5.0	10.2
	14 (7.2)	2.5	6.5	15.0
4.5 (11.4)	6 (3.1)	2.5	1.0	3.0
	8 (4.1)	3.0	2.0	4.3
	10 (5.2)	5.0	3.0	7.2
	12 (6.2)	7.0	3.5	10.2
	14 (7.2)	8.5	4.5	15.0
CONDITIONS: Gain: 3-1, Tab No. 3, 34 in. lb moment, wedges Nos. 3, 4 STB				

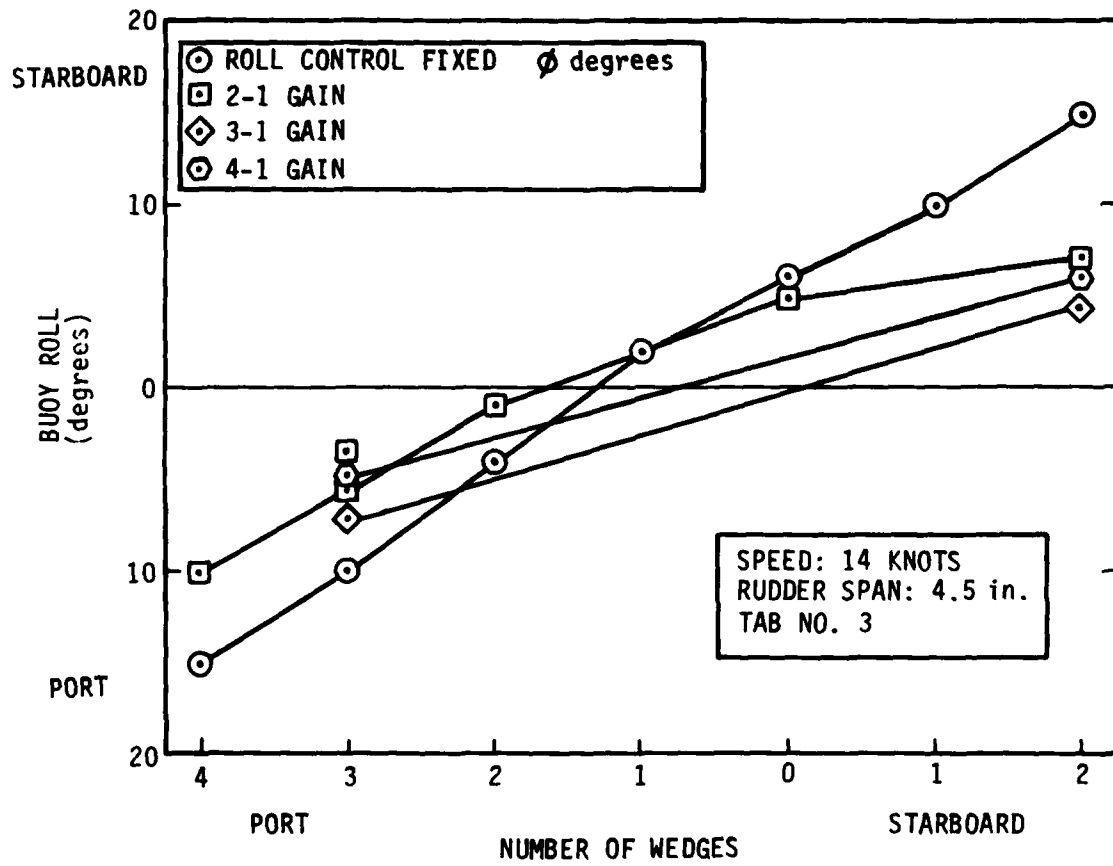

Figure 5 - Roll Angle as a Function of the Number of Wedges for Various Gain Values

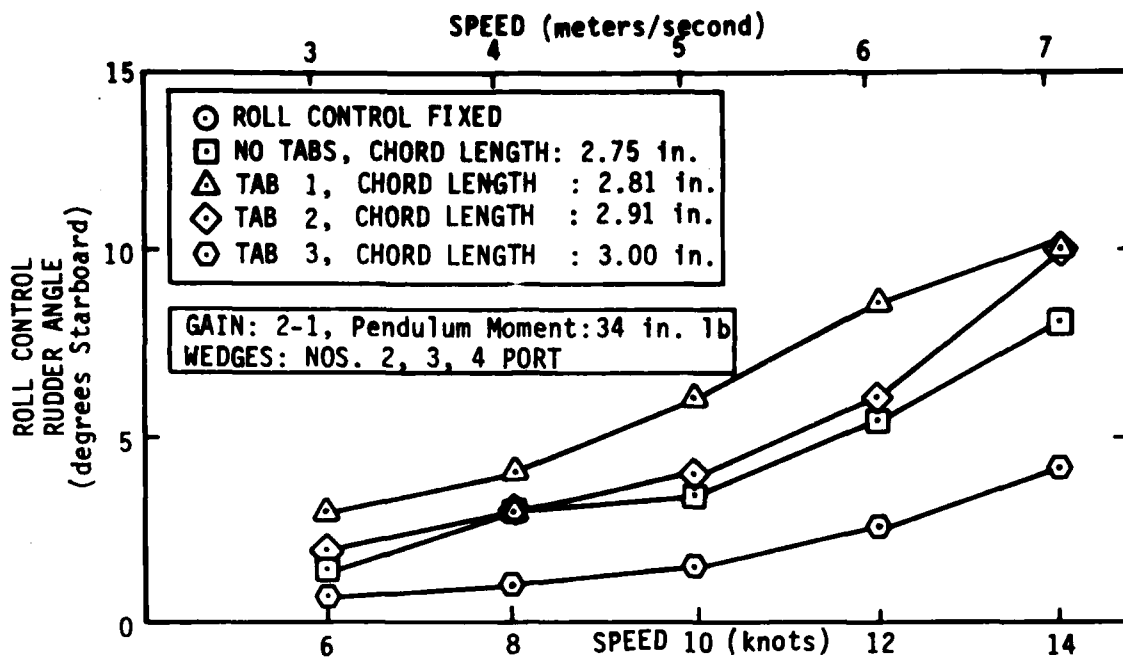

Figure 6a - Roll Control Rudder Angle as a Function of Speed for Various Chord Lengths

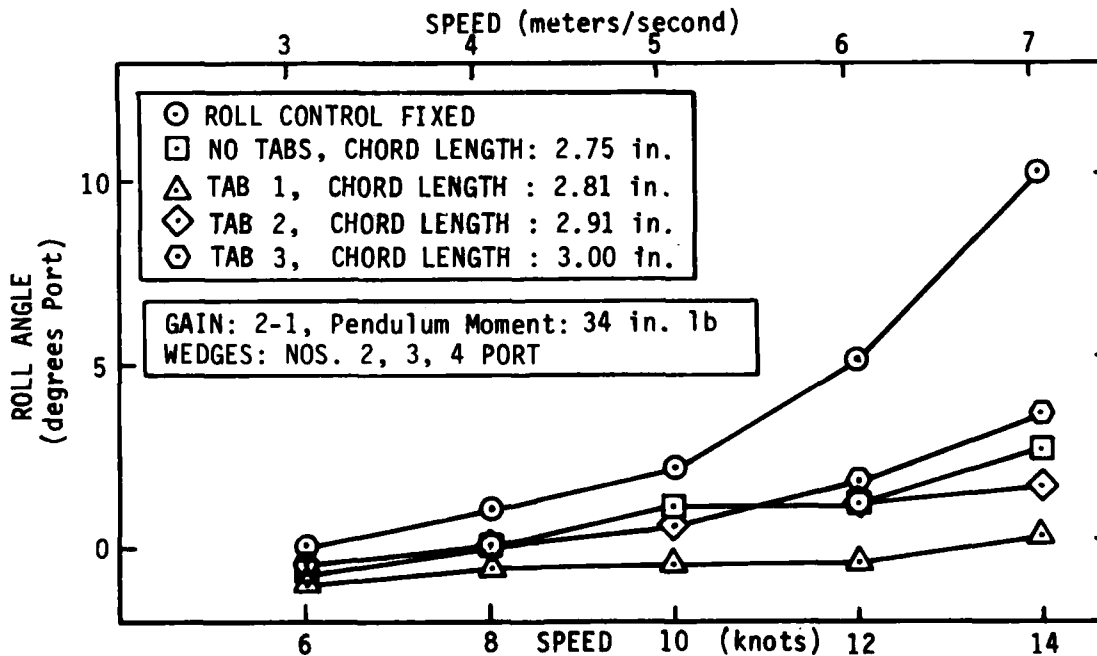

Figure 6b - Roll Angle as a Function of Speed for Various Chord Lengths

Figure 6 - Roll Angle and Rudder Deflection as a Function of Speed for Various Chord Lengths

no tabs at all. Using no tabs (2.75-in. (6.98-cm) chord length or 3.8 percent pivotal) provides less rudder deflection and less roll correction than Tabs No. 1 or No. 2. Tab No. 1 (2.81-in. (7.14-cm) chord length or 31.2 percent pivotal) has a generally higher rudder deflection than Tab No. 2 (2.91-in. (7.39-cm) chord length or 30.1 percent pivotal), and the Tab No. 1 roll correction is also better than Tab No. 2.

CONCLUSIONS

The following conclusions are based on the results of this evaluation:

1. The greater pendulum moment of 34 in. lb (3.84 Nm) is more effective than 24 in. lb (2.71 Nm).
2. The 4.5-in. (11.4-cm) rudder span is more effective than the 9.0-in. (22.9-cm) span.
3. A variation in the gain factor between 2 to 1 and 4 to 1 had little impact on the effectiveness of the roll control system; however, a minimum gain of 2 to 1 is required.
4. Tab No. 1 with a (2.8-in. (7.14-cm) chord length or 31.2 percent pivotal) provides the best roll correction of the chord lengths evaluated.

RECOMMENDATIONS

Based on the results obtained from this investigation, the following recommendations are made:

1. Use a pendulum weight that provides a moment of 34-in. lb (3.81-Nm).
2. Use a 4.5-in. (11.4-cm) rudder span.
3. Use a rudder gain value of 3 to 1.
4. Use a chord length of 2.81 in. (7.14 cm) which provides a 31.2 percent pivot location.

DTNSRDC ISSUES THREE TYPES OF REPORTS

1. DTNSRDC REPORTS, A FORMAL SERIES, CONTAIN INFORMATION OF PERMANENT TECHNICAL VALUE. THEY CARRY A CONSECUTIVE NUMERICAL IDENTIFICATION REGARDLESS OF THEIR CLASSIFICATION OR THE ORIGINATING DEPARTMENT.

2. DEPARTMENTAL REPORTS, A SEMIFORMAL SERIES, CONTAIN INFORMATION OF A PRELIMINARY, TEMPORARY, OR PROPRIETARY NATURE OR OF LIMITED INTEREST OR SIGNIFICANCE. THEY CARRY A DEPARTMENTAL ALPHANUMERICAL IDENTIFICATION.

3. TECHNICAL MEMORANDA, AN INFORMAL SERIES, CONTAIN TECHNICAL DOCUMENTATION OF LIMITED USE AND INTEREST. THEY ARE PRIMARILY WORKING PAPERS INTENDED FOR INTERNAL USE. THEY CARRY AN IDENTIFYING NUMBER WHICH INDICATES THEIR TYPE AND THE NUMERICAL CODE OF THE ORIGINATING DEPARTMENT. ANY DISTRIBUTION OUTSIDE DTNSRDC MUST BE APPROVED BY THE HEAD OF THE ORIGINATING DEPARTMENT ON A CASE-BY-CASE BASIS.

FILMED
— 8