

AD-A114 986

DEFENCE RESEARCH ESTABLISHMENT OTTAWA (ONTARIO)
A DATA ACQUISITION SYSTEM FOR A COARSE OPTICAL POWER SPECTRUM E--ETC(U)
MAY 81 D L DESAULNIERS, C BROCHU, F PAQUET

F/G 20/6

UNCLASSIFIED

NL

1 1/2
2 1/2
3 1/2
4 1/2
5 1/2
6 1/2
7 1/2
8 1/2
9 1/2
10 1/2
11 1/2
12 1/2



END
DATE
FILMED
6 82
DTIC

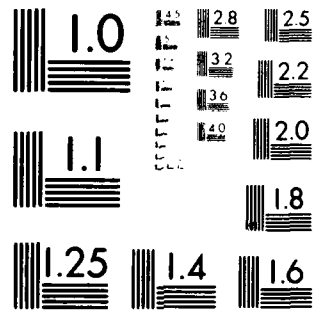

MICROCOPY RESOLUTION TEST CHART
NATIONAL BUREAU OF STANDARDS-1963-A

AD A 114986

3

RESEARCH AND DEVELOPMENT BRANCH

DEPARTMENT OF NATIONAL DEFENCE
CANADA

DEFENCE RESEARCH ESTABLISHMENT OTTAWA

TECHNICAL NOTE NO. 81-5

A DATA ACQUISITION SYSTEM
FOR A COARSE OPTICAL POWER SPECTRUM ESTIMATOR

by

D.L. Desaulniers, C. Brochu and F. Paquet

Remote Sensing
Electronics Division

DTIC
ELECTE
MAY 26 1982
H D.

PROJECT NO.
33D00

MAY 1981
OTTAWA

DISTRIBUTION STATEMENT A
Approved for public release;
Distribution Unlimited

UNCLASSIFIED

ABSTRACT

This report describes the data acquisition system of a coarse optical power spectrum estimator (COPSE). The major components of the data system including the RS-WD6420 detector and the operating software are described and calibration data are presented. This report is intended to function primarily as a comprehensive operating manual.

RÉSUMÉ

Le but de cette note technique est de fournir un mode d'emploi détaillé à l'usager d'un système d'acquisition de données pour un estimateur de spectre de puissance optique à faible résolution. On y décrit les composantes principales du système, soient le détecteur RS-WD6420 et les logiciels appropriés, ainsi que les procédures de calibration.



Accession For	
NTIS GRA&I <input checked="" type="checkbox"/>	
DTIC TAB	
Unannounced	
Justification	
By _____	
Distribution/	
Availability Codes	
Dist	Avail and/or Special
A	

UNCLASSIFIED

UNCLASSIFIED

TABLE OF CONTENTS

	<u>PAGE</u>
<u>ABSTRACT/RÉSUMÉ</u>	iii
<u>TABLE OF CONTENTS</u>	v
<u>LIST OF ILLUSTRATIONS</u>	vii
<u>LIST OF VARIABLES</u>	ix
1.0 <u>INTRODUCTION</u>	1
2.0 <u>RS-WD6420 DETECTOR</u>	1
2.1 <u>Detector Geometry</u>	1
2.2 <u>Response</u>	6
3.0 <u>ELECTRONIC SUBSYSTEM</u>	11
3.1 <u>Multiplex</u>	11
3.2 <u>Interface</u>	11
3.3 <u>A/D Converter</u>	17
4.0 <u>SOFTWARE</u>	21
4.1 <u>NOVA A/D Converter Program</u>	21
4.2 <u>COPSE Data Processing Program</u>	21
5.0 <u>REFERENCES</u>	24
<u>APPENDIX A: DATA ACQUISITION SYSTEM</u>	25
A.1 <u>Functional Diagrams</u>	26
A.2 <u>Specifications</u>	30
<u>APPENDIX B: NOVA A/D CONVERTER PROGRAM</u>	33
B.1 <u>Program Listing</u>	34
B.2 <u>Operating Instructions</u>	39

v

UNCLASSIFIED

UNCLASSIFIED

TABLE OF CONTENTS (Cont'd)

	<u>PAGE</u>
<u>APPENDIX C: XEROX COPSE DATA PROCESSING PROGRAM</u>	45
C.1 <u>Program Listing</u>	46
C.2 <u>Operating Instructions</u>	49
C.3 <u>Examples of Program Output</u>	51

UNCLASSIFIED

UNCLASSIFIED

LIST OF ILLUSTRATIONS

	<u>PAGE</u>
FIGURE 1 COPSE DATA ACQUISITION SYSTEM	2
FIGURE 2 RS-WD6420 DETECTOR FACE PLATE	3
FIGURE 3 RS-WD6420 DETECTOR MOUNTED IN A PRECISION POSITIONER ...	4
FIGURE 4 RS-WD6420 DETECTOR RING WIDTH VERSUS RING NUMBER	7
FIGURE 5 RS-WD6420 DETECTOR RING AREA VERSUS RING NUMBER	8
FIGURE 6 RS-WD6420 DETECTOR RELATIVE SENSITIVITY VERSUS RING NUMBER	9
FIGURE 7 RS-WD6420 DETECTOR RELATIVE SENSITIVITY VERSUS WEDGE NUMBER	10
FIGURE 8 RS-WD6420 DETECTOR, INTERFACE AND MULTIPLEX	12
FIGURE 9 DATA ACQUISITION ELECTRONIC SUBSYSTEM	13
FIGURE 10 8 BIT A/D CONVERTER CONVERSION RELATIONSHIP	18
FIGURE 11 TIME RESPONSE OF DATA ACQUISITION SYSTEM	20
FIGURE 12 FORMAT OF FILE HEADER RECORD	22
FIGURE 13 COPSE DATA ACQUISITION SYSTEM FLOW CHART	27
FIGURE 14 RS-WD6420 DETECTOR, INTERFACE AND MULTIPLEX	28
FIGURE 15 FEATURES OF DATA ACQUISITION SYSTEM	29
FIGURE 16 THE NOVA 1200 COMPUTER AND ITS ACCESSORIES	40

UNCLASSIFIED

UNCLASSIFIED

LIST OF VARIABLES

e_q	quantization error
E_n	Energy detected by the nth photo-diode
E_1	energy detected by the first photo-diode
F_n	relative light sensitivity of the nth diode
G	gain
H_n	halation constant for the nth diode
$I(R, \theta)$	intensity distribution in polar co-ordinates
i	current
i_n	current output from the nth photo-diode
$ i_n $	absolute value of the output current from the nth photo-diode
$\Delta i_n $	incremental change in the current
k	sample number
K	number of representative samples
LSB	value of the least significant bit of the A/D converter (LSB = $10 \div 256$)
L_n	digital output of the A/D converter for the nth diode
L_n^k	the kth digital output of the A/D converter for the nth diode
$\overline{L_n}$	average of the digital outputs of the A/D converter for the nth diode
M	scaling factor
n	photo-diode element number ($n = 1, 2, \dots, 32$ for the rings and $n = 33, 34, \dots, 64$ for the wedges)
R	radial distance
R_{n1}, R_{n2}	lower and upper radial limits for the nth diode
S_k	kth sample

UNCLASSIFIED

LIST OF VARIABLES (Cont'd)

θ angular distance

$\theta_{n_1}, \theta_{n_2}$ lower and upper angular limits for the nth diode

v voltage

$v_m(n)$ multiplex voltage output for the nth diode

$v_I(n)$ interface voltage output for the nth diode

$\Delta v_I(n)$ incremental change in the interface voltage output for the nth diode

$v_{Iq}(n)$ estimate of the interface voltage output for the nth diode

v_{OFF} offset voltage

x

UNCLASSIFIED

1.0 INTRODUCTION

Optical power spectrum analysis has become an important tool in many areas of research. It has been found to be useful in such diverse fields as image quality analysis [1], disease screening [2] and pattern recognition studies [3]. Determining the optical power spectrum of a transparency involves estimating the square of the modulus of the Fourier transform of its amplitude distribution. Under proper conditions, this distribution is proportional to the intensity distribution of the Fraunhofer pattern found in the back focal plane of a transform lens whose input is the coherently illuminated transparency. However, precise measurement of an optical power spectrum is difficult, time consuming and could very easily involve large data loads. For this reason, many researchers have turned to coarse sampling [1], [2], [3] and [4], sacrificing detail in the estimated pattern for increased speed and data compression.

Recognition Systems of Van Nuys, California market a series of segmented solid state detectors which are very useful for high speed parallel sampling of a Fraunhofer pattern. A data acquisition system was assembled incorporating one of these detectors (the 64-element WD-6420) into a coarse optical power spectrum estimator (COPSE).

The system consists of the detector, an electronic sub-system and software for a NOVA 1200 mini-computer and Xerox Sigma 9 computer using nine track magnetic tape (See figure 1). The user has a choice of several gains and biases, log or linear mode of operation, automatic or manual sampling and a variable sampling frequency. The signals coming from the 64 photo-diodes in the detector are first multiplexed onto one channel. The multiplexed signal is amplified, biased and amplified again before it is sampled and digitized. The digital samples are then stored on the magnetic tape for later processing. The major components of the system are described below. The implementation of the system to estimate optical power spectra will be reported in subsequent publications.

2.0 RS-WD6420 DETECTOR

2.1 Detector Geometry

Figure 2 shows a schematic of the face plate of the RS-WD6420 detector. The detector is mounted (figure 3) in a precision positioner that allows for four degrees of freedom. It is composed of 32 independent ring and wedge elements plus two 20° dead scratch pads. The rings provide information on the spatial-frequency profile of the detected pattern and the wedges on the direction profile. See Table I for dimensions and areas [5].

The 64 elements are mesa-diffused silicon photo-diodes. They are on a common substrate and operate in the photovoltaic or current mode. Each contains a gold conductor and is separated from the next by a light-insensitive region. The first, and only circular element, is used for alignment and to approximate the zero frequency (zero order) of the detected pattern. The

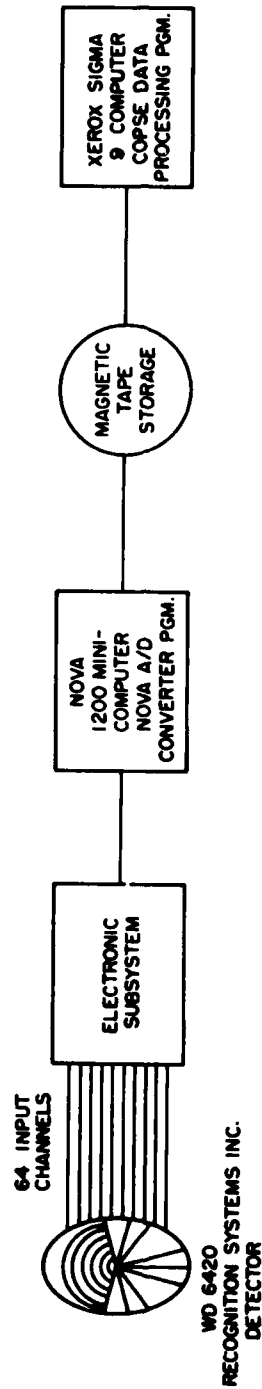

FIGURE 1 - COPSE DATA ACQUISITION SYSTEM

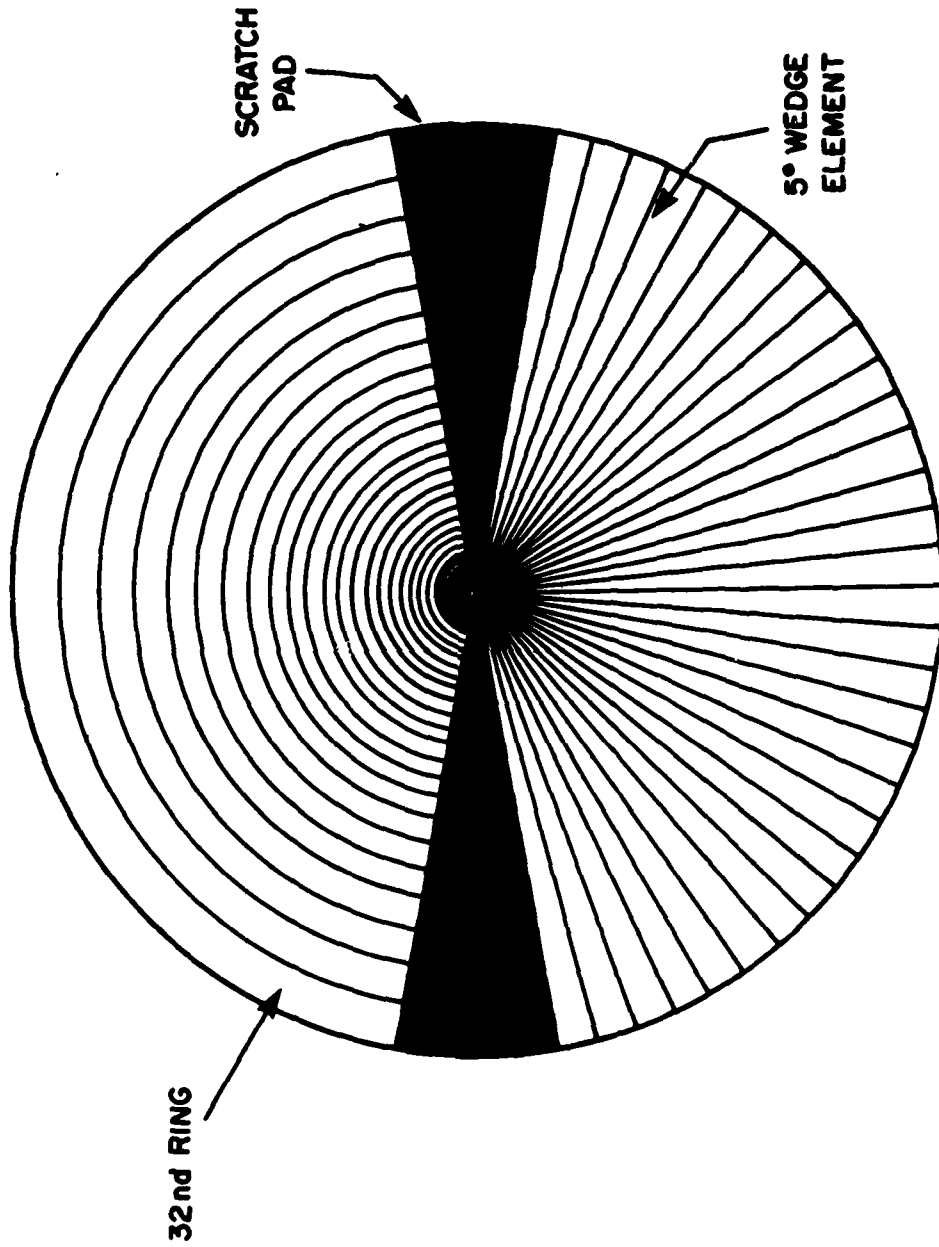

FIGURE 2 - RS-WD6420 DETECTOR FACE PLATE

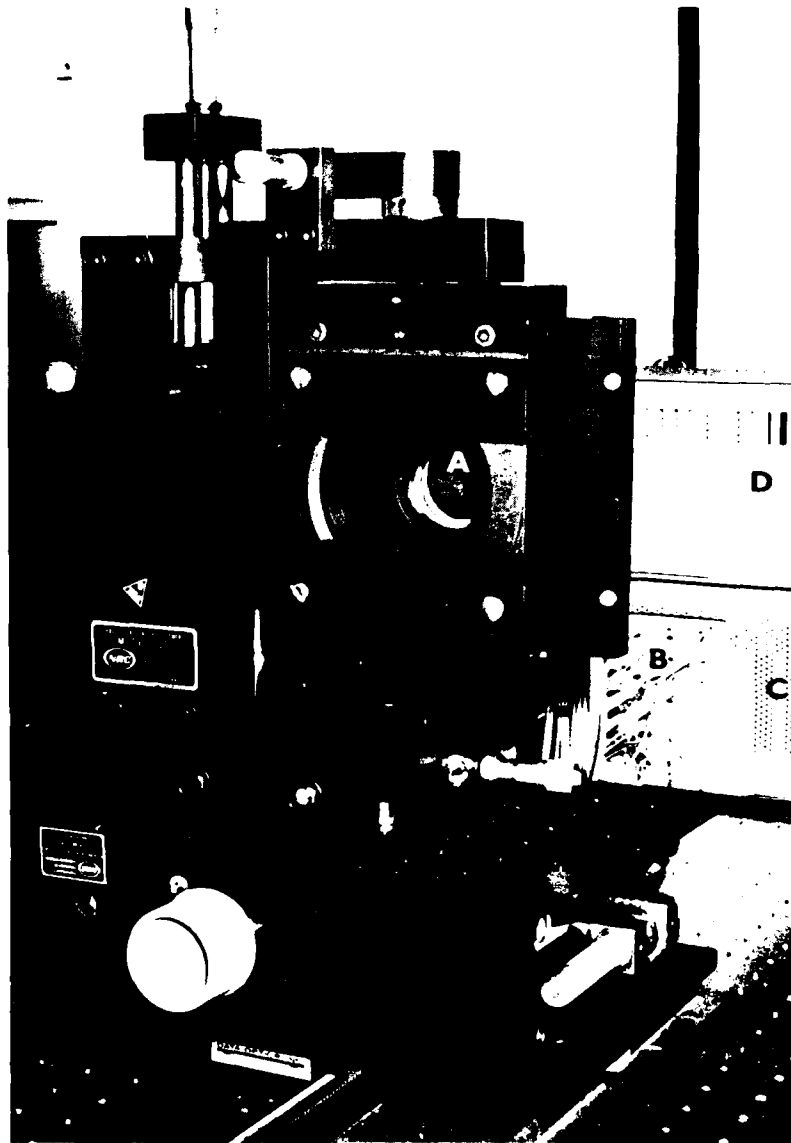

FIGURE 3 - RS-WD6420 DETECTOR MOUNTED IN A PRECISION POSITIONER

- A. RS-WD6420 Detector*
- B. 64 Channel O/F's from Detector*
- C. Back of Multiplex*
- D. Back of Interface*

TABLE I

RS-WD6420 DETECTOR DIMENSIONS

(FROM DATA SUPPLIED BY MANUFACTURER)

ELEMENT NUMBER	ANGLE (deg.)	INNER RADIUS (mm.)	INNER RADIUS METAL CONDUCTOR (mm.)	OUTER RADIUS METAL CONDUCTOR (mm.)	OUTER RADIUS (mm.)	WIDTH (mm.)	AREA (mm. ²)
1	360.0	0	0.051	0.051	0.102	0.102	0.032
2	160.0	0.165	0.193	0.218	0.244	0.079	0.030
3	160.0	0.307	0.351	0.376	0.419	0.112	0.088
4	160.0	0.483	0.539	0.564	0.622	0.140	0.176
5	160.0	0.686	0.757	0.782	0.853	0.168	0.306
6	144.2	0.917	1.001	1.026	1.113	0.196	0.435
7	147.5	1.176	1.273	1.298	1.395	0.219	0.639
8	149.9	1.458	1.527	1.593	1.702	0.244	0.903
9	151.6	1.765	1.885	1.910	2.032	0.267	1.212
10	152.9	2.096	2.223	2.248	2.390	0.295	1.612
11	160.0	2.466	2.604	2.629	2.769	0.302	2.024
12	160.0	2.845	2.995	3.020	3.170	0.325	2.517
13	160.0	3.246	3.409	3.434	3.594	0.348	3.081
14	160.0	3.670	3.843	3.868	4.041	0.371	3.719
15	160.0	4.117	4.300	4.326	4.511	0.394	4.437
16	160.0	4.587	4.780	4.806	5.001	0.414	5.203
17	160.0	5.078	5.283	4.309	5.517	0.439	6.125
18	160.0	5.593	5.809	5.834	6.053	0.460	7.063
19	160.0	6.129	6.358	6.383	6.612	0.483	8.133
20	160.0	6.688	6.927	6.952	7.191	0.503	9.253
21	160.0	7.267	7.531	7.557	7.795	0.528	10.576
22	160.0	7.872	8.146	8.171	8.420	0.549	11.901
23	160.0	8.496	8.781	8.806	9.065	0.569	13.328
24	160.0	9.142	9.426	9.451	9.733	0.592	14.927
25	160.0	9.810	10.104	10.130	10.424	0.615	16.648
26	160.0	10.500	10.805	10.831	11.138	0.638	18.495
27	160.0	11.214	11.529	11.555	11.872	0.658	20.387
28	160.0	11.948	12.276	12.301	12.629	0.681	22.488
29	160.0	12.705	13.043	13.068	13.409	0.704	24.728
30	160.0	13.485	13.835	13.858	14.209	0.724	27.009
31	160.0	14.285	14.646	14.671	15.032	0.747	29.528
32	160.0	15.108	15.479	15.504	15.875	0.767	32.085
33 to 64	5.0	1.168	-	-	15.364	-	8.81

widths and areas of the remaining 31 rings increase with ring number (figures 4 and 5). Consequently, the detector provides finer sampling near the zero order where most of the information in a diffraction pattern is found. The coarser high frequency sampling tends to average out the noise and produce a more stable and representative spectrum.

Conversely, the 32 wedges are of equal area. They have an inner radius of 1.168 mm., an outer radius of 15.364 mm., and an included angle of 5°. Therefore, they don't provide any directional information for that part of the detected pattern covered by the first six rings.

2.2 Response

The photo-diodes do not have equal sensitivity to light. Using the data supplied by the manufacturer, a plot of sensitivity (normalized to that of the first ring) with element number takes the form of the curves in figures 6 and 7. Furthermore, the detector is covered by a glass plate which is anti-reflection coated for 6328 Angstroms. This plate protects the photo-diodes from damage but it also causes a halation effect similar to that which occurs in film: a halo appears around any focused spot on the detector. So, letting $I(R,\theta)$ represent the intensity distribution in polar co-ordinates (R,θ) of the pattern to be sampled, the energy measured by the nth diode is

$$E_n = \int_{R_{n1}}^{R_{n2}} \int_{\theta_{n1}}^{\theta_{n2}} R I(R,\theta) d\theta dR \quad (1)$$

where (R_{n1}, R_{n2}) and $(\theta_{n1}, \theta_{n2})$ are its radial and angular limits respectively. Consequently, the magnitude of its output current i_n is

$$|i_n| = \frac{E_n}{F_n} + E_1 H_n \quad (2)$$

where F_n relative sensitivity for the nth diode
 H_n halation constant for the nth diode
 E_1 energy detected by the first ring

$$\int_{R_{11}}^{R_{12}} \int_0^{360} R I(R,\theta) d\theta dR \quad (3)$$

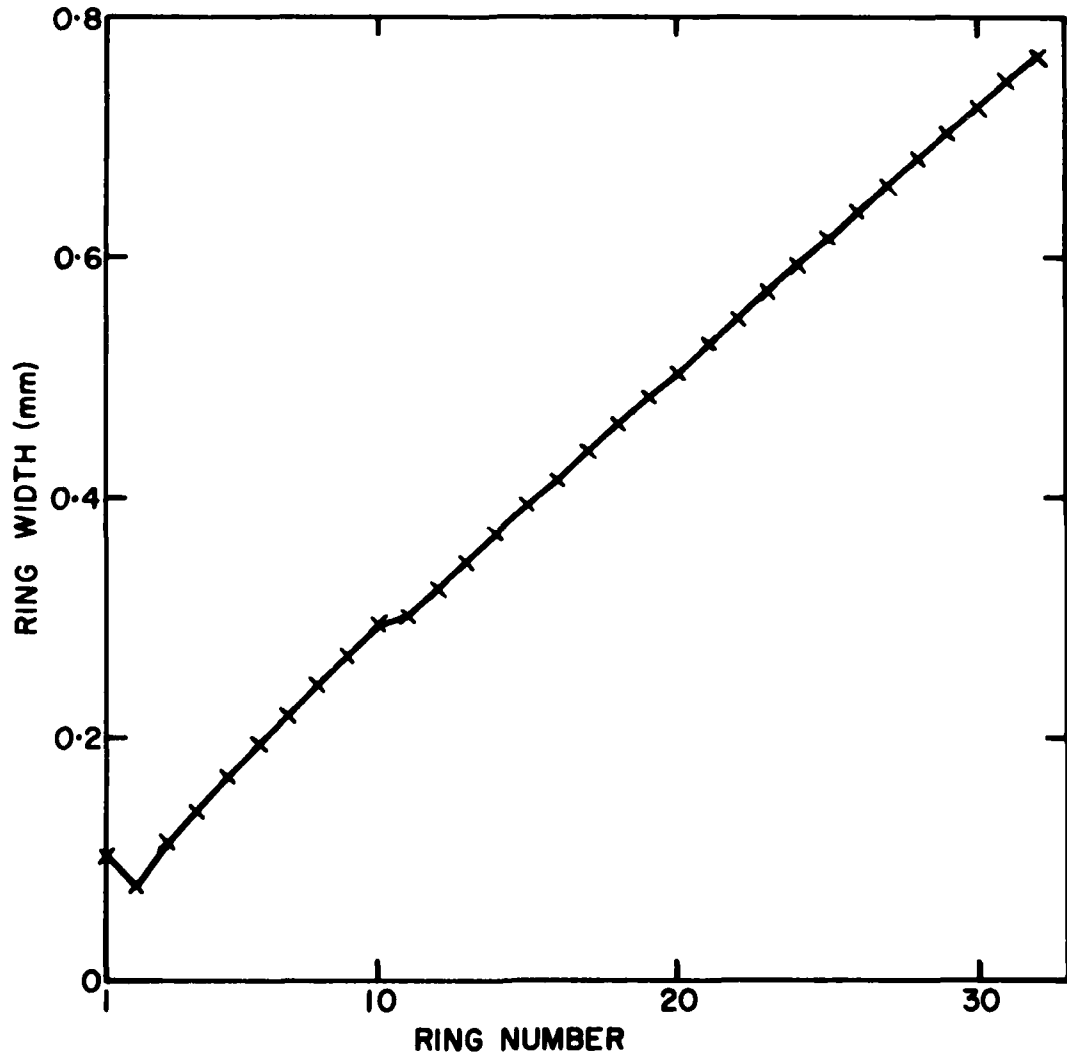

FIGURE 4 - RE-W 6420 DETECTOR PING WIDTH VERSUS RING NUMBER

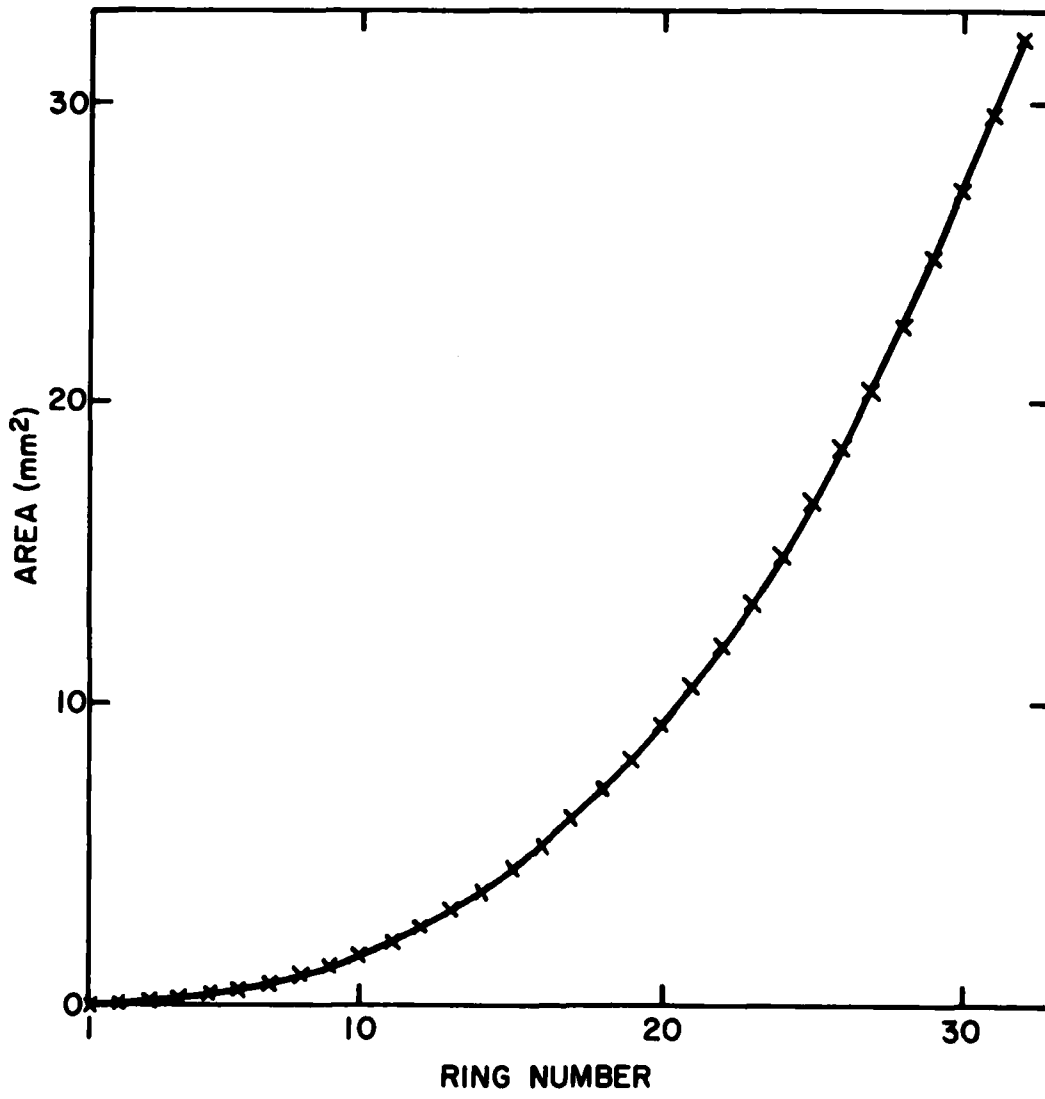

FIGURE 5 - EC-FIG-450 REFLECTOR RING AREA VERSUS RING NUMBER

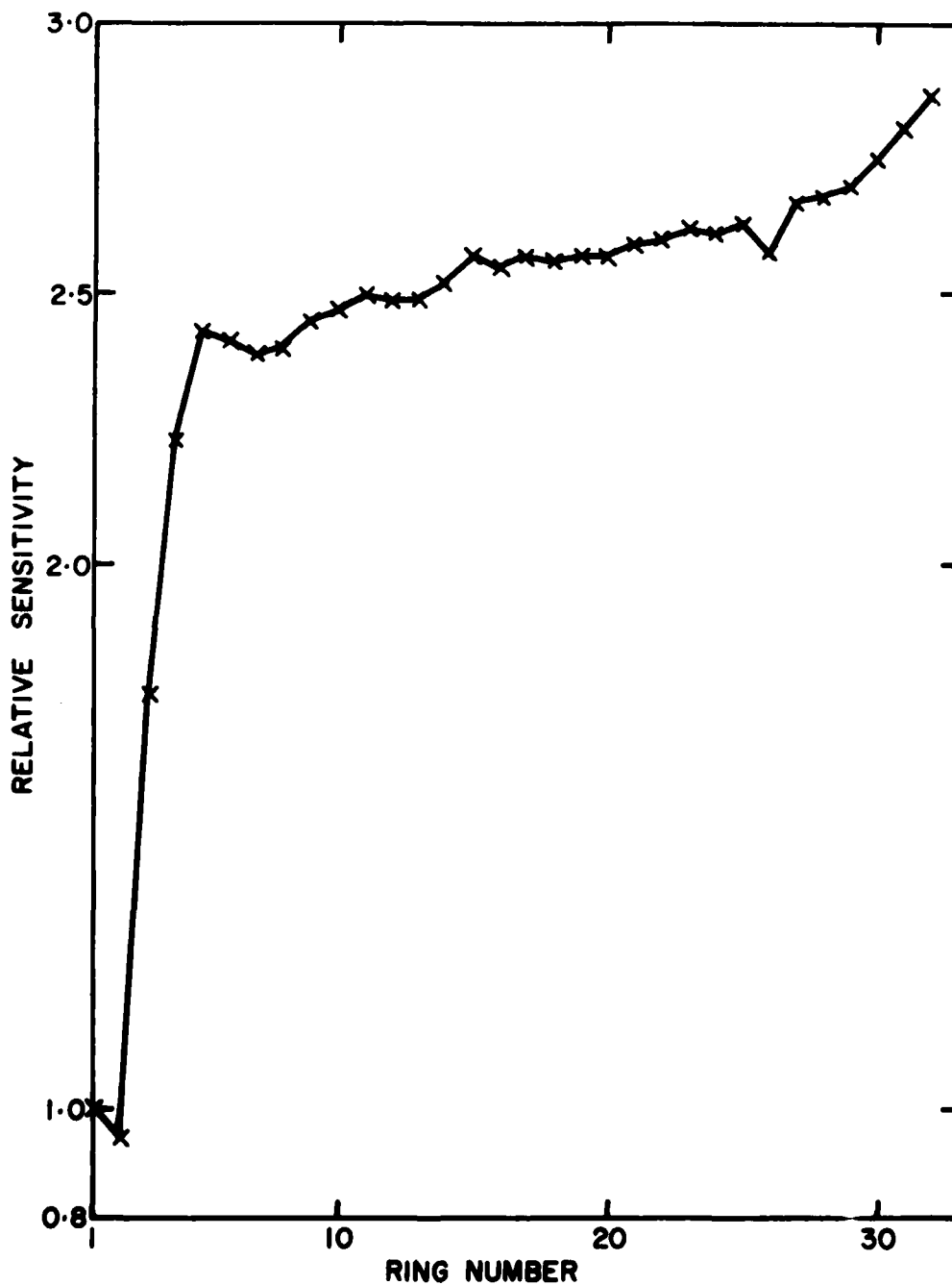

FIGURE 1 - RE-BOUNDED DETECTOR RELATIVE SENSITIVITY VERSUS RING NUMBER

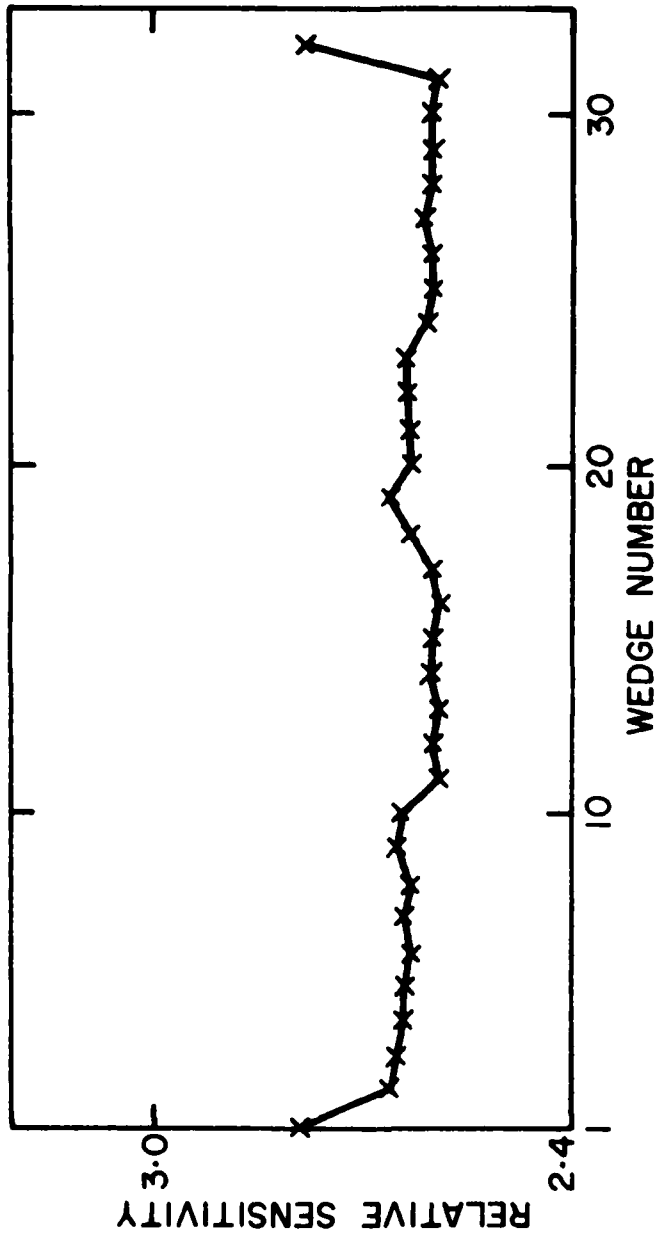

FIGURE 7 - RS-WD642C DETECTOR RELATIVE SENSITIVITY VERSUS WEDGE NUMBER

Note, i_n has reversed polarity and

n = element number

$n = 1, 2, 3, \dots, 64.$

(4)

The first 32 element numbers are the ring numbers; the last 32, the wedge numbers.

3.0 ELECTRONIC SUBSYSTEM

The electronic subsystem (figures 8 and 9) is composed of three devices: a multiplex, an interface and an 8 bit Data General A/D converter.

3.1 Multiplex

The signals coming from the 64 photo-diodes are first passed to the 64 input channels of the multiplex where they are switched either manually or automatically onto one channel. The switching is accomplished so as to reduce leakage currents and cross talk. Whenever one of the channels is switched, the other 63 are grounded.

The multiplex gives the user the choice of two modes of operation: log and linear. In linear mode, the output of the multiplex is essentially across a 10K resistive load. Letting $V_m(n)$ represent the multiplex output voltage for the n th diode,

$$V_m(n) = -|i_n| \times 10^4 \text{ volts.} \quad (5)$$

In log mode, the Analog Device model 752P logarithmic transconductor in the multiplex accepts only negative currents. It has a reference current of 10 μ amps and is adjusted to give two volts per decade:

$$V_m(n) = 2 \log_{10} \left(\frac{10 \mu\text{amps}}{|i_n|} \right) \text{ volts.} \quad (6)$$

3.2 Interface

The A/D converter has an input voltage range of only 0 to 10 volts. To fully utilize this range, the interface supplies the user with a choice of three gains: 0.833, 1 and 5; two scaling factors: 1 and 10; and seven offset voltages: 0, 2, 4, 6, 8, 10 and 12 volts.

$$V_I(n) = -C [N V_m(n) + V_{OFF}] \text{ volts.} \quad (7)$$

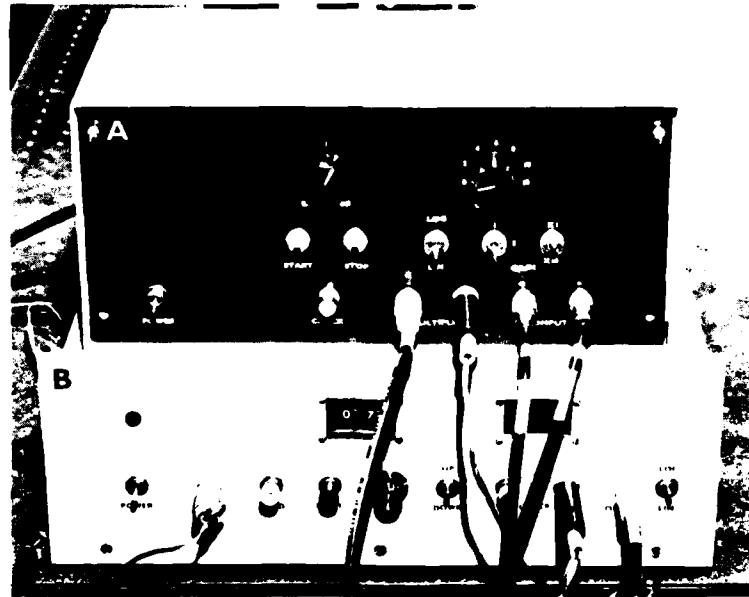
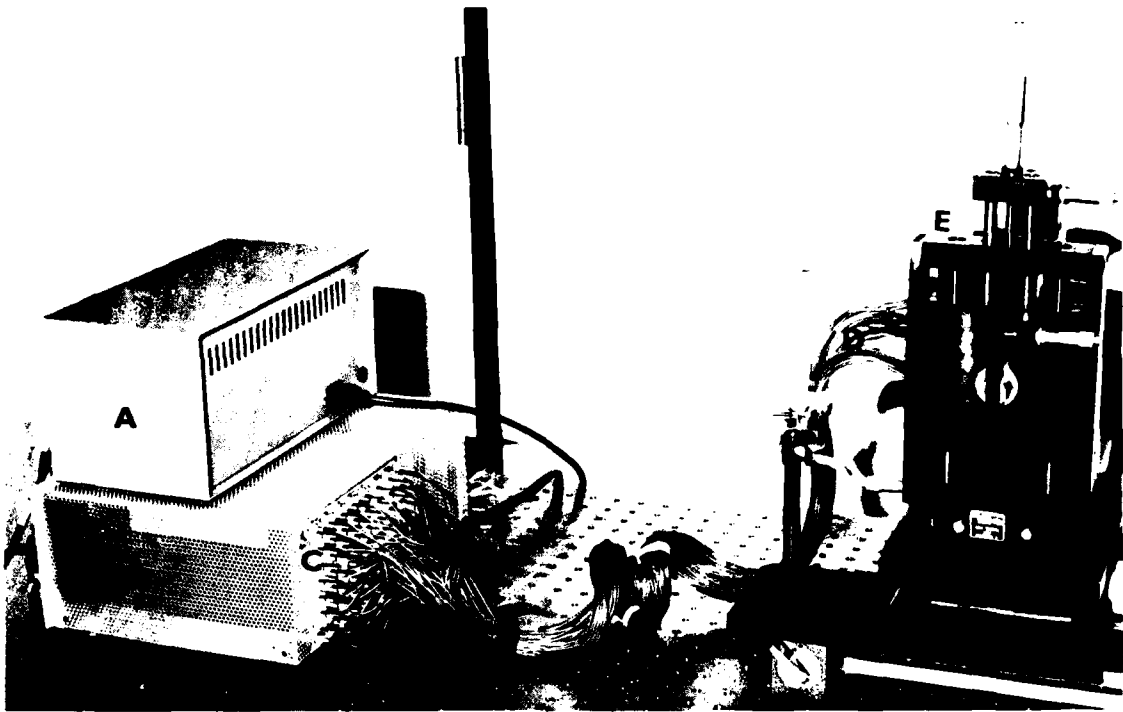

FIGURE 8 - RS-WD6420 DETECTOR, INTERFACE AND MULTIPLEX

- A. Interface
- B. Multiplex
- C. 64 Input Channels of Multiplex
- D. 64 Output Channels of RS-WD6420 Detector
- E. Mounted RS-WD6420 Detector

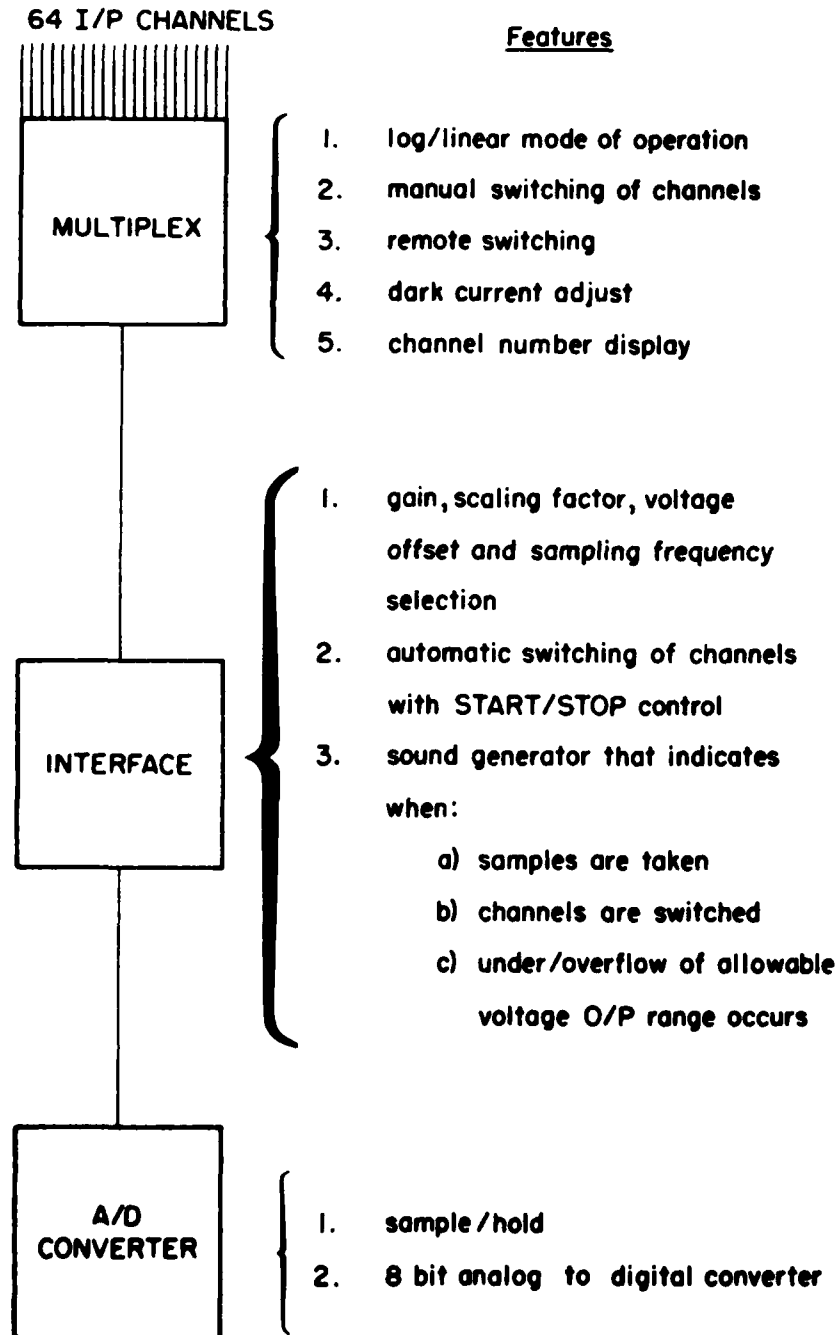

FIGURE 2 - A/D ACQUISITION ELECTRONIC SUB-SYSTEM

where $V_I(n)$ = interface output voltage for the nth diode

G = gain

M = scaling factor

V_{OFF} = voltage offset.

Substituting for $V_m(n)$ from (5) yields, for the linear mode of operation,

$$V_I(n) = G (M |i_n| \times 10^4 - V_{OFF}) \text{ volts.} \quad (8)$$

Hence, for $V_I(n)$ to be within the input voltage range of the A/D converter,

$$\frac{0.1}{M} \left(\frac{10}{G} + V_{OFF} \right) \geq |i_n| \geq \frac{0.1}{M} V_{OFF} \text{ milliamps} \quad (9)$$

The absolute diode current ranges according to equation 9 are listed in Table II for various combinations of gain, scaling factor and voltage offset. The blank entries correspond to where $|i_n|$ does not fall within the recommended input diode current range given in Appendix A for the multiplex on linear.

The scaling factor M is used only on linear but the interface does supply, on log, an additional 8 volt offset:

$$V_I(n) = -G [V_m(n) + V_{OFF} - 8] \text{ volts.} \quad (10)$$

Combining equations (6) and (10) and solving $|i_n|$ it can be shown that, for $V_I(n)$ to be within the range of the A/D converter on log,

$$10 \frac{5}{G} + \frac{V_{OFF}}{2} \geq |i_n| \geq 10 \frac{V_{OFF}}{2} \text{ nanoamps.} \quad (11)$$

The absolute diode current ranges according to equation 11 are listed in Table III. The blank entries are where $|i_n|$ does not fall within the recommended input diode current range on log for the multiplex.

TABLE II
ABSOLUTE DIODE CURRENT RANGES ON LINEAR

IN MILLIAMPS

V_{OFF} (Volts)	G = 0.833, M = 1	G = 0.833, M = 10	G = 1, M = 1	G = 1, M = 10	G = 5, M = 1	G = 5, M = 10
0	- to 1.2	- to 0.12	- to 1.0	- to 0.10	- to 0.2	- to 0.02
2	0.2 to -	0.02 to 0.14	0.2 to 1.2	0.02 to 0.12	0.2 to 0.4	0.02 to 0.04
4	0.4 to -	0.04 to 0.16	0.4 to -	0.04 to 0.14	0.4 to 0.6	0.04 to 0.06
6	0.6 to -	0.06 to 0.18	0.6 to -	0.06 to 0.16	0.6 to 0.8	0.06 to 0.08
8	0.8 to -	0.08 to 0.20	0.8 to -	0.08 to 0.18	0.8 to 1.0	0.08 to 0.10
10	1.0 to -	0.1 to 0.22	1.0 to -	0.10 to 0.20	1.0 to 1.2	0.10 to 0.12
12	- to -	0.12 to 0.24	- to -	0.12 to 0.22	- to -	0.12 to 0.14

TABLE III
ABSOLUTE DIODE CURRENT RANGES ON LOG

V_{OFF} (Volts)	LOW VALUE OF $ i_n $	HIGH VALUE OF $ i_n $		
		$G = 0.833$	$G = 1$	$G = 5$
0		1.006 milliamps	0.1 milliamps	10.0 namps
2	0.01 μ amps	-	1.0 milliamps	0.1 μ amps
4	0.1 μ amps	-	-	1.0 μ amps
6	1.0 μ amps	-	-	10.0 μ amps
8	10.0 μ amps	-	-	0.1 milliamps
10	0.1 milliamps	-	-	1.0 milliamps
12	1.0 milliamps	-	-	-

The ratio of $\Delta V_I(n)$, an incremental change in $V_I(n)$, to that in $|i_n|$; $\Delta|i_n|$, is

$$\frac{V_I(n)}{\Delta|i_n|} = G \times M \times 10^4 \quad (12)$$

on linear and

$$\frac{\Delta V_I(n)}{\Delta|i_n|} = \frac{0.869 G}{|i_n|} \quad (13)$$

on log. Obviously, log should be used whenever, for a given scaling factor M,

$$|i_n| \leq \frac{86.9}{M} \text{ } \mu\text{amps} \quad (14)$$

and especially when

$$|i_n| \leq 8.69 \text{ } \mu\text{amps} \quad (15)$$

since it gives better resolution in the low diode current range than does the linear mode.

3.3 A/D Converter

The analog-to-digital converter, one of several that can be obtained from Data General for its NOVA 1200 mini-computer, can do a maximum of 62 K conversions per second [6]. It consists of a sample and hold unit plus an 8 bit successive-approximation converter. The SAMPLE/HOLD samples the output of the interface for a short period of time and then holds the sample constant during its digital conversion. The converter essentially divides its 10 volt input range into 256 levels and assigns an unique binary integer code to the levels (figure 10). The code for each level corresponds to the nominal mid-range voltage of the level [7]. $V_I(n)$ is consequently coded with a binary number whose decimal equivalent L_n satisfies

$$\frac{L_n - 0.5}{25.6} \leq V_I(n) \leq \frac{L_n + 0.5}{25.6} \quad (16)$$

where L_n is an integer between 0 and 255. Reversing the process results in $V_I(n)$ being approximated by

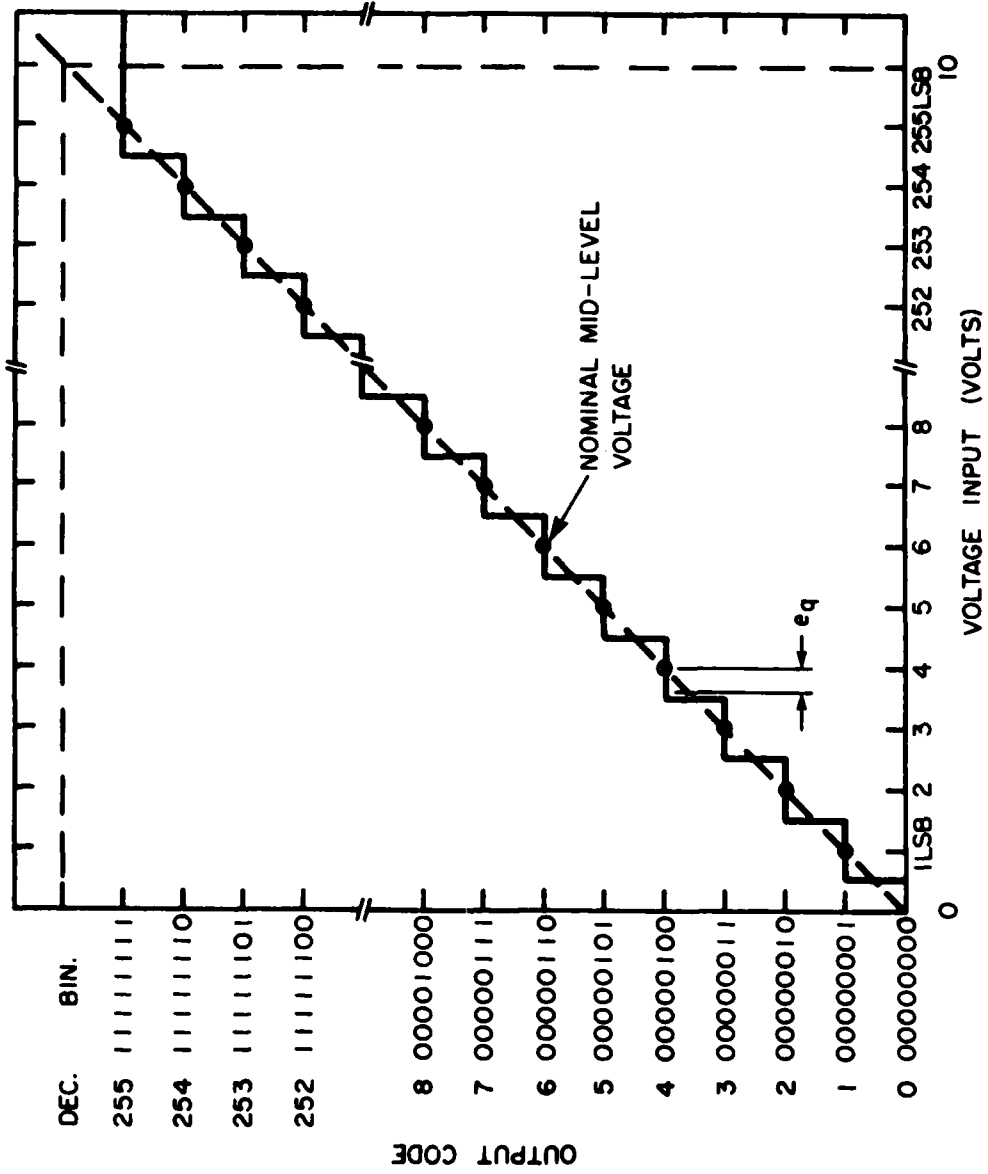

FIGURE 10 - 8 BIT A/D CONVERTER CONVERSION RELATIONSHIP
 (LSB = 10/256, e_q = QUANTIZATION ERROR)

$$V_{Iq}(n) = \frac{L_n}{25.6} \quad (17)$$

Note, the subscript q denotes the operation of quantization.

Quantization introduces an irreducible error

$$e_q = V_I(n) - V_{Iq}(n) \quad (18)$$

that is dependent on the number of levels. This error has a value of zero at the mid-points and, in this case, -0.0781 and 0.0781 volts at the lower and upper ends of each level.

The interface sends a series of triggering pulses to the SAMPLE/HOLD unit of the A/D converter; the frequency of which is under the control of the user. After each set of 64 pulses have been sent, the multiplex automatically switches to the next input channel. Thus, during one sampling cycle, the 64 diodes are each sampled 64 times making a total of 4096 samples.

On linear, the system response is critically damped. The sampling frequency doesn't matter. On the other hand, the lower the input diode current, the slower will be the response of the logarithmic amplifier in the multiplex. Referring to figure 11, when the absolute value of the diode current is less than 10 nanoamps, the system tends to have an exponential-like response. For diode currents with magnitudes greater than 10 nanoamps, it has a faster response but there is some ringing. Obviously, if the A/D converter is triggered to sample before the logarithmic amplifier has had enough time to adjust to the change in its input, the resulting sample will not be representative of the input diode current; for example, sample $S_k + 1$ in figure 11.

Therefore, system speed has to be balanced with the number of non-representative samples that can be tolerated. According to Appendix A, the logarithmic amplifier has a 1 msec. time constant when the diode current is -3 nanoamps. It follows then, to successfully sample the entire recommended diode current range on log, the sampling frequency should be less than 1000 Hz. Tests done in the lab showed that, with a sampling frequency of 2490 Hz, only those diodes whose output current magnitudes were greater than 1 μ amp were free from bad samples. In fact, some diodes had as many as sixteen bad samples. At 500 Hz, there was still a problem with currents less than 10 nanoamps in magnitude but, at the most, only three samples per diode were out of specification. It is recommended that the user work with sampling frequencies of the order of 500 Hz or less and be prepared to drop the first four samples of each diode.

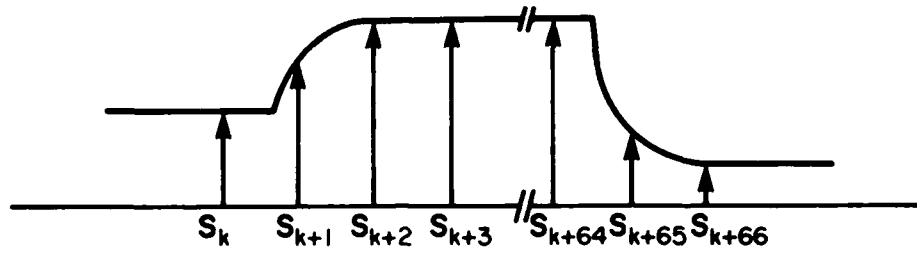

(a)

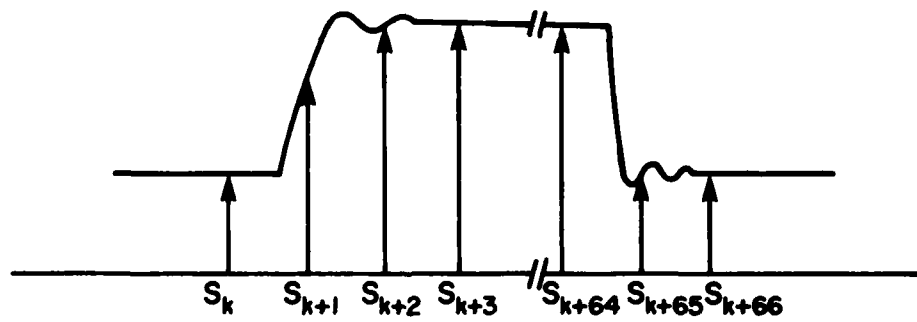

(b)

FIGURE 11 - TIME RESPONSE OF DATA ACQUISITION SYSTEM

(a) $|i_p| < 10 \text{ nA}$ (b) $|i_p| > 10 \text{ nA}$ $(s_k: k\text{th sample})$

4.0 SOFTWARE

4.1 NOVA A/D Converter Program

The NOVA A/D Converter program, run on the NOVA 1200 mini-computer, stores the sampled 8 bit binary codes on a 9 track magnetic tape. A listing of the program along with a detailed set of operating instructions can be found in Appendix B. The codes are stored one per 16 bit word, 4096 per data record. A data record, therefore, contains the samples from one complete sampling of the detector. The Program is interactive. It queries the user as to which tape file to store the data on, the number of data records and, after the asked for number of records have been stored, whether or not to continue. If the answer is yes, the new records are stored in the next sequential file on the tape. The program also stores information concerning the experiment in the first record of the file. The format of this 73 character long header record (figure 12) is critical since it is instrumental in the subsequent processing of the samples.

4.2 COPSE Data Processing Program

The APL COPSE data processing program is run on a Xerox Sigma 9 computer. A listing of the program plus operating instructions is given in Appendix C. The main function of the program is to read-in, clean-up and process the data on the tape from one experiment. The program first reads in the header record, converts it into ASCII characters and decodes it to determine the number of data records in the file, the mode of operation and the interface settings of the experiment. The data records are then each assigned a sampling frequency, gain, voltage offset, scaling factor, and neutral density transmittance before they are read in one-by-one and processed. During the processing, the binary samples in each record are converted to their integer decimal equivalents. If the user wishes, the samples are plotted as a function of element number and, using these plots, the user has the option of specifying the number of samples to drop per diode. The default number is four. The program next calculates the average of the remaining samples. Letting L_n^k represent the kth digital output of the A/D converter for the nth diode, it calculates

$$\bar{L}_n = \frac{1}{K} \sum_{k=1}^K L_n^k \quad (19)$$

where k is the number of representative samples per diode for each of the diodes. Thus $|i_n|$ is estimated to be, via equations (5), (6), (8), (10) and (17),

$$|i_n| = \frac{0.1}{M} \left(\frac{\bar{L}_n}{25.6 G} + V_{OFF} \right) \quad \text{milliamps} \quad (20)$$

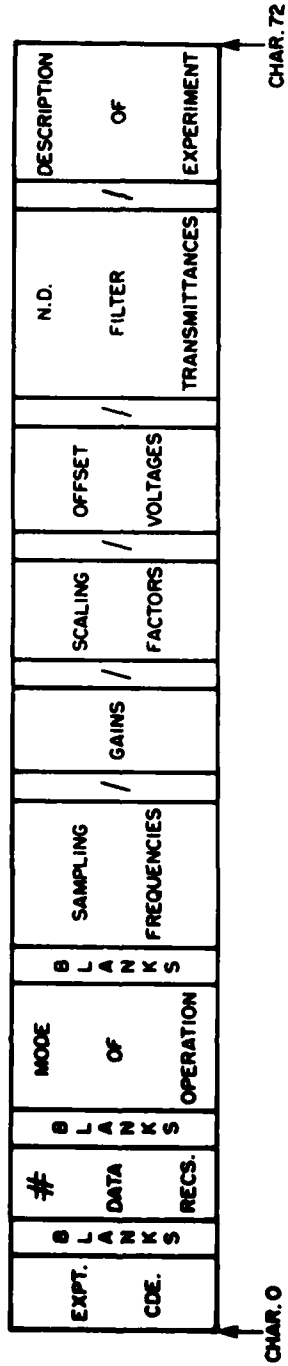

FIGURE 13 - FORMAT OF FILE HEADER RECORD

on linear and

$$|i_n| = 10 \left(\frac{\bar{L}_n}{51.2 \text{ G}} + \frac{V_{OFF}}{2} \right) \text{ nanoamps} \quad (21)$$

on log.

The program does not correct for dark currents since the coarse resolution of the A/D converter makes this correction insignificant. However, before the detected optical power spectrum can be estimated, the following would have to be corrected for:

1. relative light sensitivity of the photo-diodes
2. uneven illumination of the input transparency
3. halation effects
4. time fluctuations in the illuminating light.

Furthermore, if the optical power spectrums of two or more transparencies are to be compared, the difference between their average film densities have to be taken into account. Since these corrections depend on the geometry of the optical segment of COPSE system, they will be discussed only in a future report.

5.0 REFERENCES

1. N.B. Nill. Scene Power Spectra: The Moment as an Image Quality Merit Factor. Applied Optics vol. 15, no. 11, p 2846 1976.
2. R.P. Kruger, E.L. Hall and A.F. Turner. Hybrid Optical-Digital Radiography Based System Lung Disease Detectors. Applied Optics vol. 16, no. 10, p. 2637, 1977.
3. R.D. Leighty and G.E. Lukes. New Approach to Automated Optical/Digital Pattern Recognition. PROC. SPIE vol. 185, p.120, 1979.
4. G.E. Lukes. Rapid Screening of Aerial Photography by OPS Analysis. PROC. SPIE vol. 117, p. 89, 1977.
5. WD6430 Detector Technical Specifications. Recognition Systems Inc.
6. How to Use the NOVA Computer. Data General Corporation, 1971.
7. Analog - Digital Conversion Handbook. Analog Devices Inc. 1972.

UNCLASSIFIED

25

APPENDIX A
DATA ACQUISITION SYSTEM

UNCLASSIFIED

A.1. Functional Diagrams

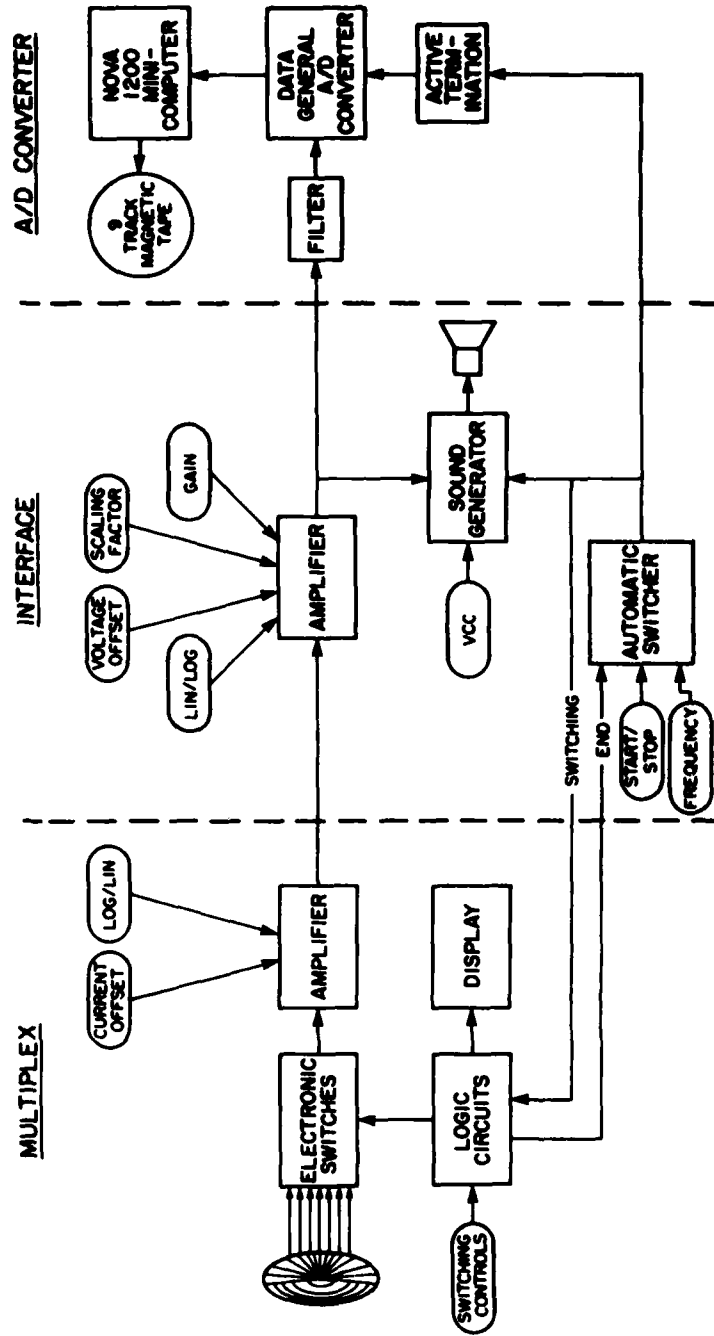

FIGURE 13 - COPSE DATA ACQUISITION SYSTEM FLOW CHART

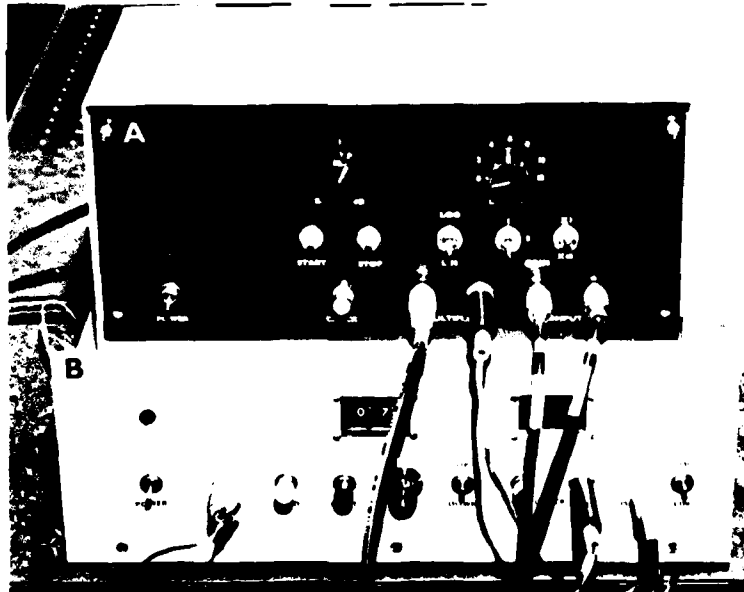
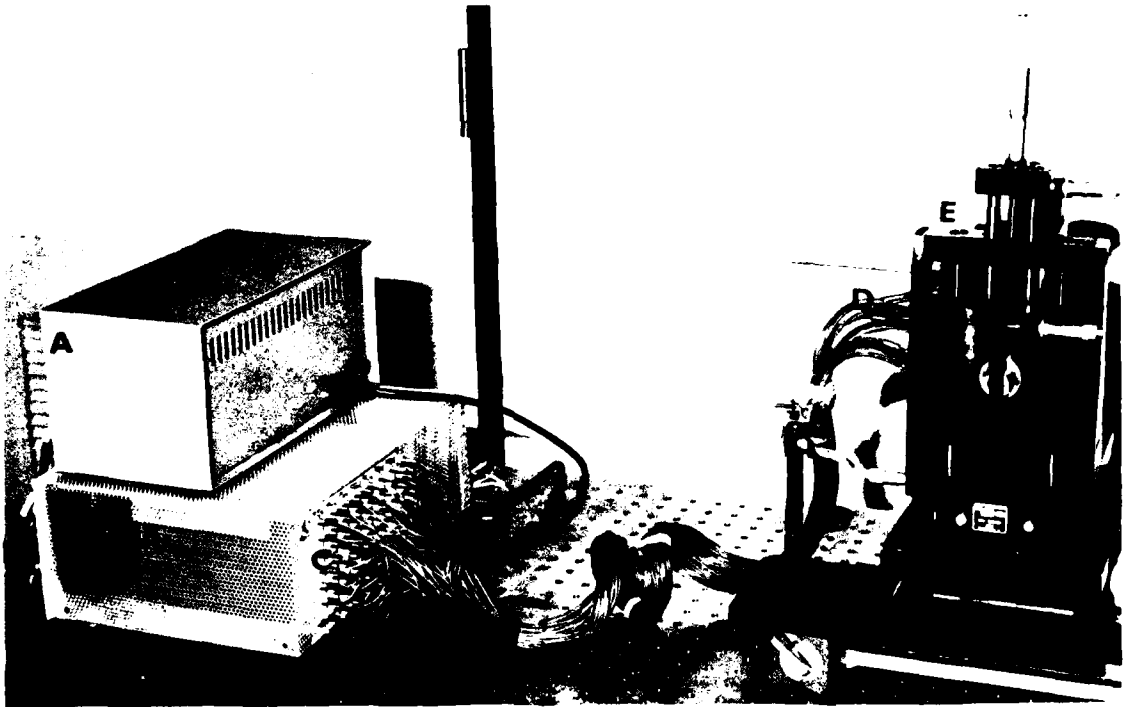

FIGURE 14 - RS-WD6420 DETECTOR, INTERFACE AND MULTIPLEX

- A. Interface
- B. Multiplex
- C. 64 Input Channels of Multiplex
- D. 64 Output Channels of RS-WD6420 Detector
- E. Mounted RS-WD6420 Detector

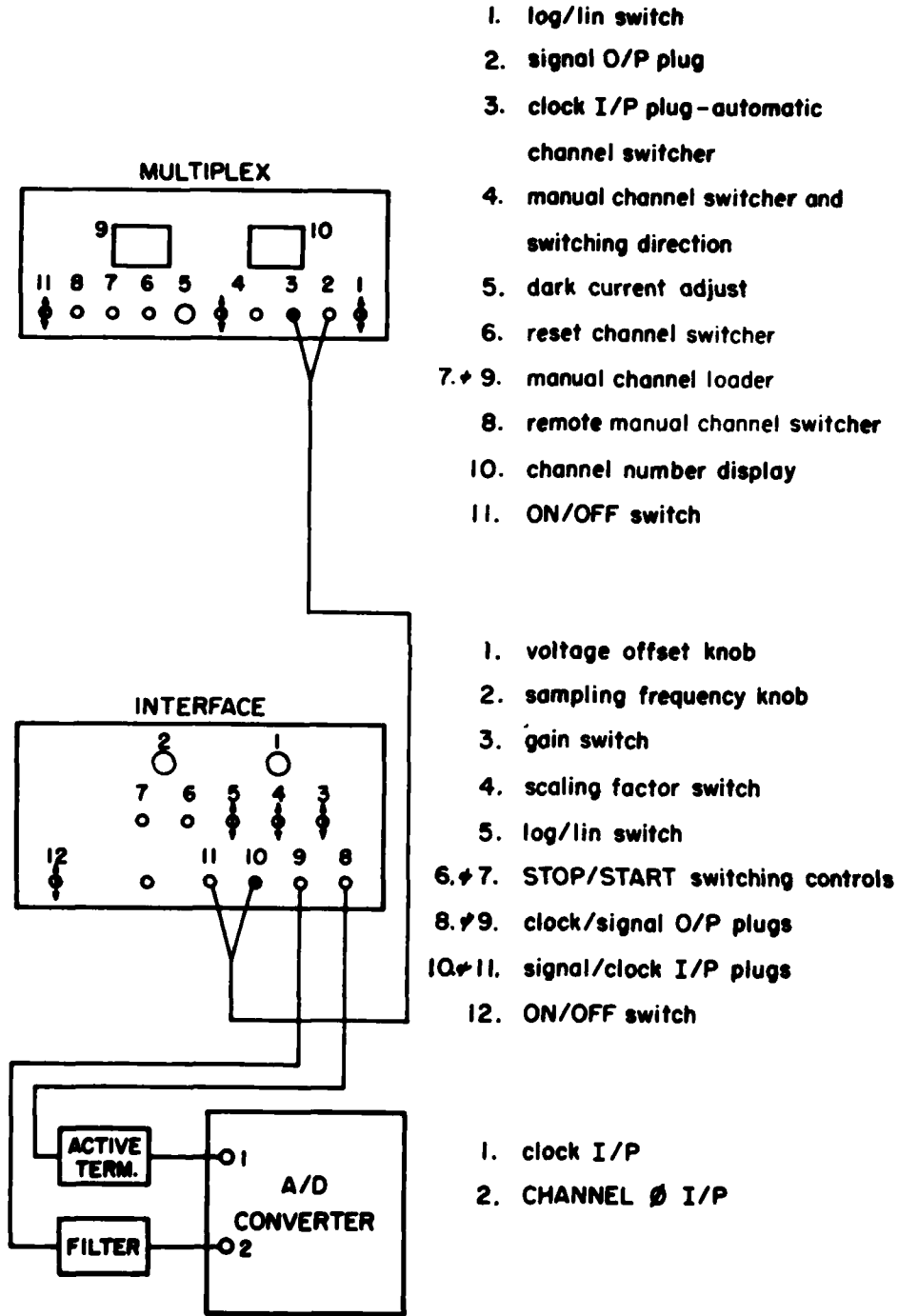

FIGURE 15 - FEATURES OF DATA ACQUISITION SYSTEM

A.2. SpecificationsMultiplex

1. Transfer Function : on linear $V = -|i| \times 10^4$ volts
on log $V = 2 \log_{10} \left(\frac{10 \mu\text{amps}}{|i|} \right)$ volts
2. Output Voltage : -13.5 to 13.3 volts into a 1 M Ω resistor
 ± 13.0 volts into a 1 K Ω resistor
3. Input Current : on linear -15* namps to -1.3 namps
on log - 3* namps to -1.0 namps
(* for 10% accuracy)
4. Time Response : on linear 30 μsec to be within 1%
on log
 $|i| < 10$ namps time constant $\approx \frac{3}{|i|} \times 10^{-9}$ sec.
 $|i| = 100$ namps 0.9 msec. to be within 1%
= 1 μamps 0.2 msec. to be within 1%
= 10 μamps 50 μsec . to be within 1%
= 0.1 namps 20
to 1 namps 20 μsec . to be within 1%
5. Switch Leakage Current : 200 pamps (open I/P)
300 pamps on channels 30 & 35
(the channels are numbered 0 to 63)
6. Output Voltage Drift : ± 20 μvolts withing 2 hrs.
7. Offset Voltage (Trimpot): ± 100 μvolts

Interface

1. Transfer Function : on linear $V = -G(M V_{in} + V_{OFF})$ volts
on log $V = -G(V_{in} + V_{OFF})$ volts

- 2. Output Voltage : -0.05 to 10.2 volts
- 3. 3 dB Frequency Cut-Off : 58 KHz when $G = 5$
18 KHz when $G M = 50$
- 4. Input Bias Current Error: ± 0.2 namps
- 5. Output Voltage Drift : < 5 μ volts
- 6. Scaling Factor, Gain & Voltage Offset Precision: 0.03%
- 7. Sampling Frequency : 1.2 Hz to 2.6 KHz
- 8. Test Clock Output : 28 μ sec. TTL O/P with a 27 Ω resistor
- 9. Sampling Pulse : 0.6 μ sec. +2 volts into a 50 Ω resistor

Filter - low pass RLC, 2^o order

- 1. 3 dB Cut-off Frequency : 40 KHz
- 2. I/O DC Resistance : 600 Ω

Active Termination

- 1. Input Impedance : 50 Ω to ground with I/P voltage of 0 to 2 volts
- 2. Output : open collector
500 Ω to 5 volts (500 Ω resistor in A/D converter)
 I_c max. (sink) \approx 100 milliamps

UNCLASSIFIED

33

APPENDIX B
NOVA A/D CONVERTER PROGRAM

UNCLASSIFIED

B.1 Program Listing

The following program listing does not include the NOVA library subroutines: TAPE, TYO, TY1 and ACCEPT, which are called by the program.

```

INC      1,1      SZR
JMP      .-2

JSR      @.TYO      ;HEADER RECORD PROMPT
M3
JSR      @.TYI      ;INPUTS ASCII CODE FOR INFO.
BUFA     ;HEADER RECORD
JSR      @.TAPE     ;WRITE INFO. RECORD ON TAPE
50
BUFA
C37
;
JSR      @.TYO      ;NO OF RECORDS PROMP
M4
JSR      @.ACCEPT   ;INPUT NO OF RECORDS
-1
NREC
JMP      A4

;
.TYI:    TYI      ;CHARACTER TELETYPE
.TYO:    TYO      ;I/O ROUTINES
.TAPE:   TAPE     ;TAPE ROUTINE
.ACCE:   ACCEPT   ;NUMERICAL TELETYPE
;INPUT ROUTINE
FN:      0        ;FILE NO
WDCT:    -4096.   ;NEGATIVE RECORD WORD COUNT
NREC:    0        ;NO OF RECORDS
CONT:    0        ;CONTINUE CODE
.ADR1:   ADR1     ;ADDRESSES OF ADCV
.ADR2:   ADR2     ;STORAGE BUFFERS
.BUFA:   BUFA
C37:     -37.
;
;
A4:      SUB      0,0      ;FIRST/FINAL CHANNEL SELECT
LDA      1,.ADR1     ;ADDRESS OF BUFFER 1
LDA      2,WDCT     ;NEGATIVE WORD COUNT
SKPBZ    ADCV      ;WAIT FOR ADCV TO BE FREE
JMP      .-1
DOA      0,ADCV     ;LOAD ADCV CHANNEL REGISTER
DOB      1,ADCV     ;LOAD ADCV ADDRESS COUNTER
DOCP     2,ADCV     ;LOAD ADCV WORD COUNTER, START ADC
SKPBZ    ADCV      ;WAIT FOR ADCV TO FINISH
JMP      .-1
;
TAP1:    JSR      @.TAPE ;WRITE BUFFER 1 ON TAPE
50
ADR1     -4096.
DSZ      NREC      ;CHECK ALL RECORDS DONE
JMP      A3        ;NO
JMP      OUT       ;YES
;
A3:      SUB      0,0      ;FIRST/FINAL CHANNEL SELECT

```



```
DR1:      .BLK      4096.  
ADR2:      .BLK      4096  
;  
;  
          .END      START  
;
```

B.2 Operating Instruction (See figure 16)

1. Turn on the

- a) A/D converter
- b) NOVA computer and computer console
- c) the teletype
- d) 256 K word fixed head disc located in the cabinet below the teletype
- e) tape drive, interface and fan.

The data and clock cables from the interface should be connected to the first input channel and the oscillator input respectively of the converter. The magnetic tape transport select should be on zero.

2. If the Infrared Spectrometer has been used since the last time the program was run, the Disc Operating System (DOS) must be bootstrapped from tape and installed in the fixed head disc. However, the Spectrometer must first be turned on by

- a) opening the valve of its nitrogen gas coolant (the needle on the dial with the red lettering should move)
- b) turning on its power supply

to disable any interrupts from it. It can be turned off once the A/D converter program is running. To bootstrap and install the DOS

- a) Mount the 28K magnetic tape
 - i) press the LOAD/UNLOAD button on the tape drive
 - ii) mount the tape without a WRITE ring (The FILE PROTECT light will come on)
 - iii) press the LOAD/UNLOAD button again and close the cabinet door
 - iv) press the FORWARD button (The tape will advance until the loadpoint, marked by a silver strip, is reached. The loadpoint is the logical beginning of the tape.)
 - v) press the REMOTE button to put the tape unit on line.
- b) On the computer console, there are 16 data switches through which binary addresses and data can be supplied, and a series of operating switches. Using these switches, a loader program which loads the system from the magnetic tape, is first stored at locations 376_8 and 377_8 in the computer by
 - i) entering the address 376_8
 - ii) lifting the EXAMINE switch
 - iii) entering the instruction code 60122_8
 - iv) lifting the DEPOSIT switch.



- A. *Tape Drive Controls*
- B. *Tape Drive Cabinet Door*
- C. *Tape Drive Interface*
- D. *Tape Drive Fan*
- E. *A/D Converter*
- F. *A/D Converter Clock Input* }
- G. *A/D Converter Data Input* } *From Interface Unit*
- H. *Computer on/off Switch*
- I. *Computer Console on/off Key*
- J. *Data Switches*
- K. *Operation Switches*
- L. *Teletype on/off Switch*
- M. *Fixed Head Disc on/off Switch*
- N. *Nitrogen Gas Coolant For Spectrometer*
- O. *Spectrometer Power Switch*
- P. *Data Cables from Interface Unit*

FIGURE 16 - THE NOVA 1200 COMPUTER AND ITS ACCESSORIES

Next, the instruction to jump to location 377₈ is stored at 377₈ by

- i) entering the address 377₈
- ii) depressing the DEPOSIT NEXT switch.

The stored instructions are executed by

- i) entering the address 376₈
- ii) lifting the RESET switch and then the START switch.

- c) If all has gone well, the message

FULL (ϕ) OR PARTIAL (I)?

will be printed by the teletype. The system is asking the user if he wishes a full or partial initialization of the DOS file directory. A partial initialization is done only when the DOS has been loaded already.

- d) File 16 on the tape contains the DOS and the A/D program so, to load the converter program key in

LOAD/V MT0:16

on the teletype. The teletype will list the programs loaded and will respond with the ready message:R.

- e) Dismount the DOS tape by

- i) pressing the STOP/START button on the tape drive to take the tape unit off-line
- ii) pressing the LOAD/UNLOAD button and dismounting the tape.

- f) Install the fixed head disc as the only device from which the DOS can be bootstrapped by keying in

INSTALL SYS.SV

The teletype will answer back with the ready message. Now, if at any time, the DOS has to be re-bootstrapped, the same procedure is followed as before except that instead of the instruction previously stored at loc. 376₈, the instruction to start the fixed head disc is stored instead. The code for this instruction is 60120₈ and the teletype will respond with the messages

DOS REV 05

R

- 3. Mount the data tape and call the NOVA A/D converter program.

- a) Mount a data tape with a WRITE ring on the tape drive. The FILE PROTECT light should not go on.
- b) Key in, to call the NOVA A/D converter program,

COPSE

The program will be loaded into core starting at loc. 1000₈. To restart the program

- i) depress the STOP operating switch
- ii) enter the address 1000₈
- iii) lift the RESET switch and then the START switch

5. Run the NOVA A/D converter program.

- a) The teletype will respond with the message

A/D CONVERTER

INPUT TAPE FILE NO. >

asking the user to key in the file number on the tape where the data is to be stored. The number should be one greater than the number of files already on the tape.

- b) The teletype will then answer back with the prompt

INPUT COMMENTS (UP TO 73 CHARACTERS)

for the user to type in the header record. This is the first record in the file and contains information concerning the experiment. It's format (figure 11) is as follows

- i) experimental code - character string used to identify the data file
- ii) at least one blank
- iii) number of data records in the file - the number of times the RS-WD6420 detector is to be completely sampled during one experiment
- iv) optional blanks
- v) mode of operation - LG for log, LN for linear
- vi) optional blanks
- vii) sampling frequency in hertz in order of usage - default of 500
- viii) a slash
- ix) gains in order of usage - default of 1
- x) slash
- xi) scaling factors in order of usage - default of 1
- xii) slash
- xiii) offset voltages - default of 0
- xiv) slash
- xv) neutral density transmittance settings - default of 1

- xvi) slash
- xvii) description of experiment - short character string containing information the user might think is important.

Note, the processing program assumes a one-to-one correspondence between the number of data records and the gain, scaling factor, offset voltage, transmittance and sampling frequency entries. If, for any of these settings, the number of entries is less than the number of data records, the last entry is assumed to apply to the overflow.

- c) Next, the prompt

NO OF RECORDS >

will be printed asking the user to type in the number of data records. Sampling will only begin after the START button on the interface has been pressed. After each record has been stored on the tape, the Start button has to be pressed again.

- d) When the asked for number of records have been stored, the message

ENTER 1 TO CONT., 0 TO STOP >

will appear on the teletype's output. Keying in 1 causes the program to re-cycle. The new records are stored in the next file on the tape. Keying in 0 rewinds the tape.

UNCLASSIFIED

45

APPENDIX C
XEROX COPSE DATA PROCESSING PROGRAM

UNCLASSIFIED

C.1 Program Listing

A listing of the main program RDCOPSE is given along with that of its three subroutines: ASC, CPIX1 and PLOTT.

```

▽ RDCOPSE FN
[1]  *
[2]  * DATA PROCESSING PROGRAM
[3]  * COARSE OPTICAL POWER SPECTRUM ESTIMATOR
[4]  *
[5]  STRP 5;ε')SET □ IN DC/','FN,',';SIZE=8192';BL←70ρ' '
[6]  DES+I[N+ρI]+HDR;I←('/'=HDR+ASC,φ37 2ρ□)/173 * DECODE HEADER
RECORD
[7]  EXPCDE←HDR[1-1+J1+HDR[1I[1]]1' '];I←I,(1+I)+15-N
[8]  →S2;A←HDR[J1+1J2-J1+1],HDR[J2+1+1I[1]-J2+2];OP←HDR[J2+1];→(
(I[1]+1)=J2+HDR[1I[1]]1'L')/S1
[9]  S1:OP+'N';A←HDR[J1+1I[1]-J1+1]
[10] S2:→S4;SF←NRρ500;NR←A;→(2≠ρ1,A←εA)/S3
[11] S3:SF←SF,(NR+1-ρ0,SF)ρ-1+0,SF←1+A;NR←A[1]
[12] S4:G←G,(NR+1-ρG,0)ρ-1+1,G←εHDR[I[1]+1I[2]-I[1]+1]
[13] M←M,(NR+1-ρM,1)ρ-1+1,M←εHDR[I[2]+1I[3]-I[2]+1]
[14] VOFF←VOFF,(NR+1-ρVOFF,0)ρ-1+0,VOFF←εHDR[I[3]+1I[4]-I[3]+1]
[15] TR←TR,(NR+1-ρTR,1)ρ-1,TR←εHDR[I[4]+1I[5]-I[4]+1]
[16] *
[17] S5:'EXPT. NO. = ' ; EXPCDE; ' DESCRIPTION- ' ; DES; ER * O/P
EXPT. CONSTANTS
[18] 'NO OF DATA RECORDS = ' ; NR
[19] 'SAMPLING FREQUENCIES = ' ; SF
[20] 'MODE OF OPERATION = L'; ((OP='G'),(OP='N'))/'OI'; OP
[21] 'GAINS = ' ; G
[22] 'SCALING FACTORS = ' ; M
[23] 'OFFSET VOLTAGES = ' ; VOFF
[24] 'ATTENUATOR TRANSMITTANCES = ' ; TR
[25] *
[26] DO←(NR,64)ρ0;I←64ρ0;N←I;□ * PROCESSING OF DATA RECORDS
[27] S6:'RECORD ' ; N; ' PLOTT SAMPLES; -(1) FOR YES,(0) FOR NO'; D←
64 64ρCPIX1□
[28] DS←□; PLOTT N; →(∼PL+□)/S7
[29] S7:→(OP='G')/S8; I←VOFF[N]+((+/(((DSρ0),NSρ1)/D))+ (25.6×G[N]
×NS+64-DS+(∼PL),PL)/4,DS))
[30] →S9; DO[N;]←0.1×I+M[N]; CT←'MILLIAMPS' * LINEAR MODE OF OPERA
TION
[31] S8:DO[N;]←10*((I-6)+2); CT←'MICROAMPS' * LOG MODE OF OPERATI
ON
[32] S9:BL; BL; 'PROCESSED DATA-RECORD NO. ' ; N; ' |I| IN ' ; CT; ER *
OUTPUT PROCESSED DATA
[33] , 'A1'ΔFM'RING'; , 'A6'ΔFM' ' ; , 'A1'ΔFM'INTENSITY'; , 'A6'ΔFM' ' ;
, 'A1'ΔFM'WEDGE'; , 'A6'ΔFM' ' ; , 'A1'ΔFM'INTENSITY'
[34] 'I2,X7,F10.3,X6,I2,X8,F10.3'ΔFM(132;DO[N;132];132;DO[N;32+
32]); BL; BL
[35] *
[36] 'PROCESSED DATA RECORD NO. ' ; N; ' NORMALIZED TO ' ; MX; ' ' ; CT;
ER; □; K←1; MX←[DO[N;]
[37] AXES; WD 0 6 0 6; SCL -3 66 -0.05 1.1
[38] S10:→(64≥K+K+1)/S10;(K,(DO[N;K]+MX))PUT' *
[39] *
[40] →(NR≥N+N+1)/S6; ER; □
▽

```

```

▽ PLOTT N
[1]  A
[2]  A PLOTTING ROUTINE PHOTO-DIODES SAMPLES
[3]  A
[4]  L2+2.9;I+1;W1+L1+0;'RECORD NO. = ';N;' PAGE ';PG;PG+1;ER
[5]  S1:MAX+2+[/D[I;];MIN+-2+L/D[I;]
[6]  L2+2.9+L1+((L1=0)×(W1≠0))×3.1;+(5.8≥W2+W1+0.25×(MAX-MIN)/
S2
[7]  ER;□;+(L1≠0)/S2;W2+((W≤6),(W>6))/(W,6);W1+0
[8]  'RECORD NO. = ';N;' PAGE ';PG;PG+PG+1
[9]  S2:AXES;( -3,(MAX-MIN)÷2)PUT I;SCL -3 66,MIN,MAX;WD L1,L2,
W1,W2
[10] W1+W2+0.25;J+1
[11] S3:+(64≥J+J+1)/S3;(J,D[I;J])PUT'x'
[12] 'DROP ?NO. OF SAMPLES';ER;□;+(64≥I+I+1)/S1
▽

▽ Z+ASC V
[1]  Z+ASCEB ΔλL V
[2]  A ROUTINE TO TRANSLATE A CHARACTER ARRAY FROM ASCII TO EB
CDIC
▽

▽ Z+CPIX1 P;M
[1]  Z+(-M÷2)†,Q65535 65536†26 ΔF P.(M+4|ρP)ρNUL
[2]  A GIVE THE DECIMAL VALUE OF A HALF WORD CHAR STRING .
▽

```

C.2 Operating Instructions

1. Working with magnetic tapes in APL is difficult. Therefore, the first thing the user must do is dump the desired data file onto an APL public disc pack. To do this, the following instructions are executed on a terminal after the user has logged on

a) !M PLEASE MOUNT TAPE FT# nnnn (NO RING)
This is a message to the operator telling him to mount tape FT# nnnn.
(Note, nnnn stands for the serial number of the tape.)

b) !ERROR
All the messages the tape deck sends to the operator will now appear on the terminals screen. The tape deck sends the operator the message

S: MOUNT 9TA80, nnnn

until he complies with the request. The message

O: M A80

will then be sent by the operator

c) !PCL

d) >SPF FT# nnnn,m
This tells the tape deck to space forward m files. m should be one less than the desired file number.

e) >C FT# nnnn (1-1000) to DC/FN
Copies the data file onto the workspace named FN by the user. FN is a character string, usually COPSE followed by a file number. The system responds with

...COPYING

and, after the copying is complete, with

— — EOF — — ENCOUNTERED AFTER M

M gives the number of records in the file.

f) >REM FT# nnnn
Remove the tape from the tape deck. The system will send the operator the message

S: SAVE 9TA60, nnnn

until he has complied with the request. The operator will then send the message

O: S A80

g) >E

2. Working on a Techtronic terminal, the user executes the following instructions after he has logged on

```
!APL
```

```
)LOAD COPSE.420L
```

```
RDCOPSE FN
```

to call the COPSE data processing program. Remember FN is a character string. It must be enclosed in quotes.

3. The program will first decode and output the contents of the header record but it will wait for the user to press the carriage return before continuing giving the user time to copy the information.

4. Next, the message

```
RECORD 1 PLOTT SAMPLES? - (1) FOR YES, (0) FOR NO
```

and prompt for the answer

```
0:
```

appears on the screen. If the user elects to plot the samples, they are plotted as a function of element number after which the program prompts with

```
DROP? NO. OF SAMPLES
```

```
0:
```

asking the user how many samples he wishes to drop from each group of 64.

5. The estimates of $|i_n|$ for each diode are listed. Then, the program waits till the user presses the carriage return before it plots the estimates normalized to their largest value as a function of element number. Another carriage return signals the program to read in the next record and to repeat steps 4 and 5. The process continues until all of the data records in the file has been read in and processed.

C.3. Examples of Program Output

EXPT. NO. - 13 DESCRIPTION - FREQ. TEST 5
NO OF DATA RECORDS - 9
SAMPLING FREQUENCIES - 100 200 300 2490 2490 2490 2490 2490
MODE OF OPERATION - LOG
GAINS - 1 1 1 1 1 1 1 1 1
SCALING FACTORS - 1 1 1 1 1 1 1 1 1
OFFSET VOLTAGES - 0 4 4 4 4 4 4 4 4
ATTENUATOR TRANSMITTANCES - 0 1.9 1 1 1 1 1 1 1

RECORD NO. 2 PAGE 1

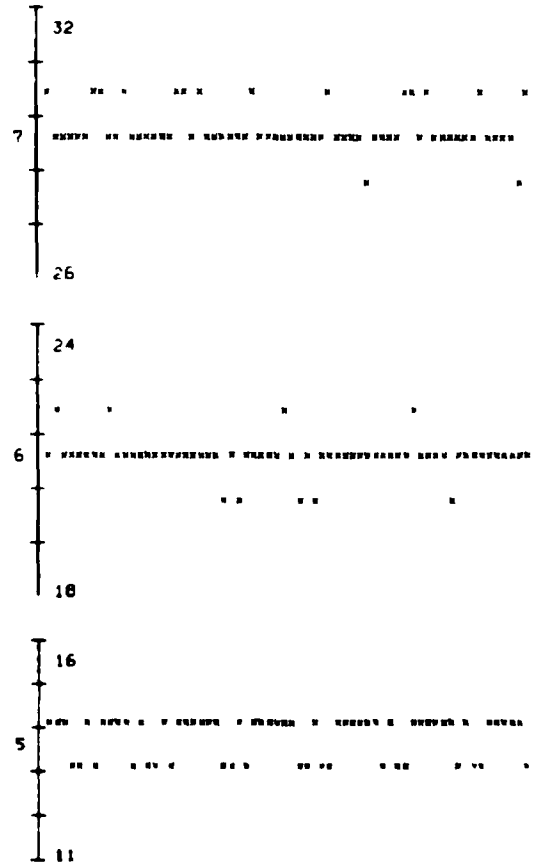
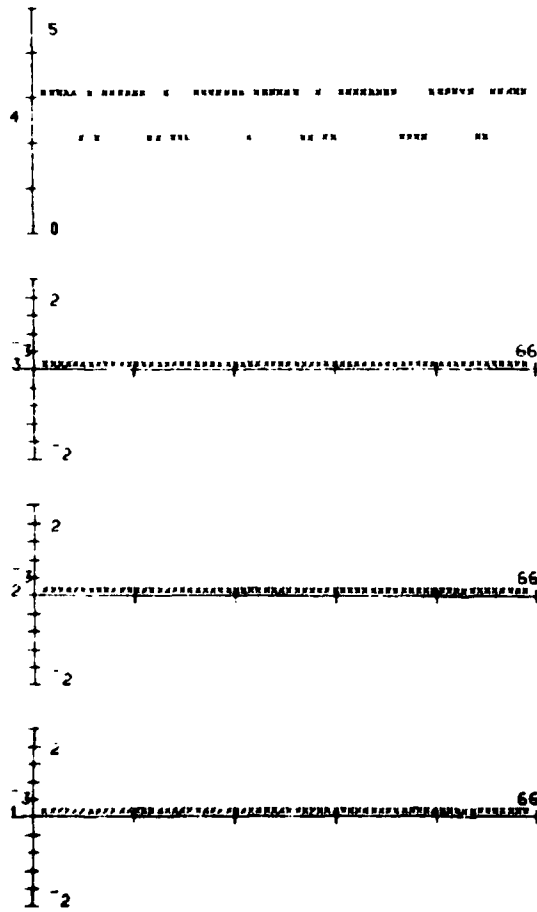

UNCLASSIFIED

PROCESSED DATA-RECORD NO. 1 III IN MICROAMPS

RING	INTENSITY	WEDGE	INTENSITY
1	0.021	1	1.548
2	0.122	2	1.492
3	0.060	3	1.482
4	0.117	4	1.331
5	0.191	5	1.274
6	0.279	6	1.222
7	0.411	7	1.192
8	0.583	8	1.141
9	0.773	9	1.145
10	1.020	10	1.115
11	1.278	11	1.163
12	1.604	12	1.185
13	2.000	13	1.223
14	2.445	14	1.270
15	2.989	15	1.322
16	3.536	16	1.407
17	4.114	17	1.496
18	4.797	18	1.582
19	5.437	19	1.687
20	6.268	20	1.806
21	7.118	21	1.908
22	8.058	22	2.088
23	8.970	23	2.220
24	10.068	24	2.393
25	11.040	25	2.616
26	12.079	26	2.847
27	13.216	27	3.071
28	14.341	28	3.345
29	15.125	29	3.668
30	15.253	30	3.954
31	17.119	31	4.271
32	19.111	32	4.656

UNCLASSIFIED

PROCESSED DATA RECORD NO. 1 NORMALIZED TO 18.01003527 MICROAMPS

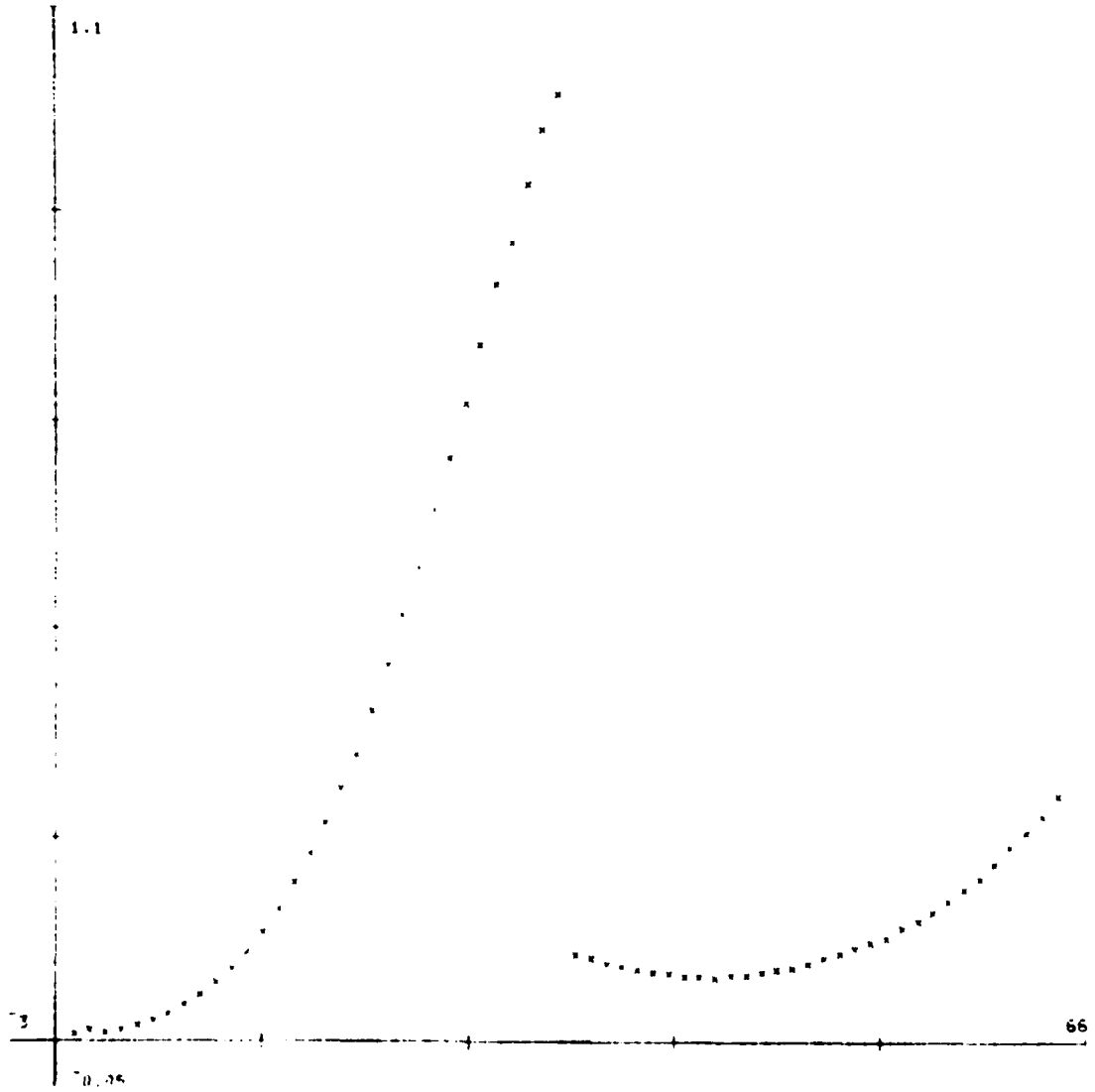

UNCLASSIFIED

Security Classification

DOCUMENT CONTROL DATA - R & D		
(Security classification of title, body of abstract and indexing annotation must be entered when the overall document is classified)		
1 ORIGINATING ACTIVITY Defence Research Establishment Ottawa, National Defence Headquarters Ottawa, Ontario, K1A 0Z4	2a. DOCUMENT SECURITY CLASSIFICATION UNCLASSIFIED	
	2b. GROUP IV	
3 DOCUMENT TITLE DATA ACQUISITION SYSTEM FOR A COARSE OPTICAL POWER SPECTRUM ESTIMATOR (U)		
4 DESCRIPTIVE NOTES (Type of report and inclusive dates) Technical Note		
5 AUTHOR(S) (Last name, first name, middle initial) Desaulniers, D.L.; Brochu, C.; & Paquet, F.		
6 DOCUMENT DATE May 1981	7a. TOTAL NO OF PAGES 58	7b. NO. OF REFS 7
8a. PROJECT OR GRANT NO. 33D00	9a. ORIGINATOR'S DOCUMENT NUMBER(S) DREO TN # 81-5	
8b. CONTRACT NO.	9b. OTHER DOCUMENT NO.(S) (Any other numbers that may be assigned this document) N/A	
10 DISTRIBUTION STATEMENT Distribution is unlimited		
11 SUPPLEMENTARY NOTES N/A	12. SPONSORING ACTIVITY CRAD/DREO	
13 ABSTRACT This report describes the data acquisition system of a coarse optical power spectrum estimator (COPSE). The major components of the data system including the RS-WD6420 detector and the operating software are described and calibration data are presented. This report is intended to function primarily as a comprehensive operating manual.		

KEY WORDS

OPTICAL POWER SPECTRUM
 PHOTO-DIODES
 A/D CONVERTER
 SEGMENTED SOLID STATE DETECTOR
 DATA PROCESSING

INSTRUCTIONS

1. **ORIGINATING ACTIVITY** Enter the name and address of the organization issuing the document.
- 2a. **DOCUMENT SECURITY CLASSIFICATION** Enter the overall security classification of the document including special warning terms whenever applicable.
- 2b. **GROUP** Enter security reclassification group number. The three groups are defined in Appendix 'M' of the DRB Security Regulations.
3. **DOCUMENT TITLE** Enter the complete document title in all capital letters. Titles in all cases should be unclassified. If a sufficiently descriptive title cannot be selected without classification, show title classification with the usual one-capital-letter abbreviation in parentheses immediately following the title.
4. **DESCRIPTIVE NOTES** Enter the category of document, e.g. technical report, technical note or technical letter. If appropriate, enter the type of document, e.g. interim, progress, summary, annual or final. Give the inclusive dates when a specific reporting period is covered.
5. **AUTHOR(S)** Enter the name(s) of author(s) as shown on or in the document. Enter last name, first name, middle initial. If military, show rank. The name of the principal author is an absolute minimum requirement.
6. **DOCUMENT DATE** Enter the date (month, year) of Establishment approval for publication of the document.
- 7a. **TOTAL NUMBER OF PAGES** The total page count should follow normal pagination procedures, i.e., enter the number of pages containing information.
- 7b. **NUMBER OF REFERENCES** Enter the total number of references cited in the document.
- 8a. **PROJECT OR GRANT NUMBER** If appropriate, enter the applicable research and development project or grant number under which the document was written.
- 8b. **CONTRACT NUMBER** If appropriate, enter the applicable number under which the document was written.
- 9a. **ORIGINATOR'S DOCUMENT NUMBER(S)** Enter the official document number by which the document will be identified and controlled by the originating activity. This number must be unique to this document.
- 9b. **OTHER DOCUMENT NUMBER(S)** If the document has been assigned any other document numbers (either by the originator or by the sponsor), also enter this number(s).
10. **DISTRIBUTION STATEMENT**: Enter any limitations on further dissemination of the document, other than those imposed by security classification, using standard statements such as:
 - (1) "Qualified requesters may obtain copies of this document from their defence documentation center."
 - (2) "Announcement and dissemination of this document is not authorized without prior approval from originating activity."
11. **SUPPLEMENTARY NOTES** Use for additional explanatory notes.
12. **SPONSORING ACTIVITY** Enter the name of the departmental project office or laboratory sponsoring the research and development. Include address.
13. **ABSTRACT** Enter an abstract giving a brief and factual summary of the document, even though it may also appear elsewhere in the body of the document itself. It is highly desirable that the abstract of classified documents be unclassified. Each paragraph of the abstract shall end with an indication of the security classification of the information in the paragraph (unless the document itself is unclassified) represented as (TS), (S), (C), (R), or (U).

The length of the abstract should be limited to 20 single-spaced standard typewritten lines, 7½ inches long.
14. **KEY WORDS**: Key words are technically meaningful terms or short phrases that characterize a document and could be helpful in cataloging the document. Key words should be selected so that no security classification is required. Identifiers, such as equipment model designation, trade name, military project code name, geographic location, may be used as key words but will be followed by an indication of technical context.

DATE
ILME
— 88