

AD-A115 103

SONEX LTD RICHLAND WA  
BOREHOLE SONAR INVESTIGATIONS AT IDAHO SPRINGS, COLORADO AND MA--ETC(U)  
FEB 82

F/G 17/1

DAAK70-81-C-0241

NL

UNCLASSIFIED

1 of 1  
AD-A115 103

END
DATE
FILED
7 82
DTIC

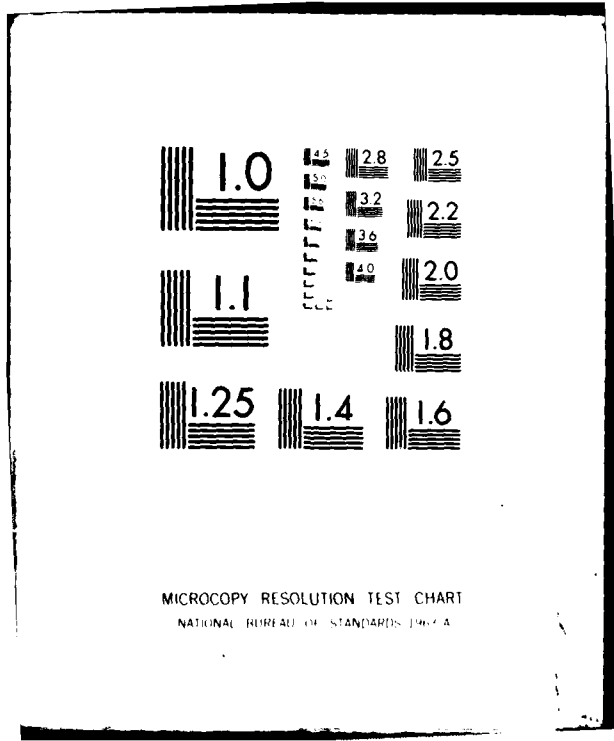

MICROCOPY RESOLUTION TEST CHART  
NATIONAL BUREAU OF STANDARDS-1963-A

12

DAAK70-81-C-0241

AD A115103

**BOREHOLE SONAR INVESTIGATIONS**

at

**IDAHO SPRINGS, COLORADO  
and  
MANATEE SPRINGS, FLORIDA**

**Conducted by**

**SONEX, LTD.  
Richland, Washington  
99352**

**Sponsored by**

**US ARMY  
Mobility Equipment Research and Development Command  
Fort Belvoir, Virginia**

**February 1982**

**SDTIC  
ELECTRONIC  
JUN 3 1982  
A**

This document has been approved  
for public release and sale; its  
distribution is unlimited.

**8 2 05 17 097**

DTIC FILE COPY

#### NOTICE

This program was conducted by SONEX under the sponsorship of the Department of the Army, U.S. Army Mobility Equipment Research and Development Command. This document is disseminated in the interest of information exchange.

The contents of this report reflect the findings and opinions of SONEX and the author, who are responsible for the facts and accuracy of the data herein. The contents do not necessarily reflect the official views or policy of the Department of the Army. This report does not constitute a standard, a specification, or a regulation.

DAAK70-81-C-0241

**BOREHOLE SONAR INVESTIGATIONS**

at

**IDAHO SPRINGS, COLORADO  
and  
MANATEE SPRINGS, FLORIDA**

**Conducted by**

**SONEX, LTD.  
Richland, Washington  
99352**

**Sponsored by**

**US ARMY  
Mobility Equipment Research and Development Command  
Fort Belvoir, Virginia**

**February 1982**



Accession For	
DTIC	<input checked="" type="checkbox"/>
IC	<input type="checkbox"/>
Unannounced	<input type="checkbox"/>
Justification	
Distribution/	
Availability Codes	
Avail and/or	
Special	
Dist	A

## TABLE OF CONTENTS

List of Figures -----	i
List of Tables -----	ii
Abstract -----	iii
Preface -----	iv
INTRODUCTION AND SUMMARY -----	1
Idaho Springs, Colorado -----	2
Manatee Springs, Florida -----	4
TECHNIQUES -----	5
Borehole Sonar -----	5
Crosshole Sonar (SX-7) -----	6
Pulse-echo Sonar (SX-8) -----	9
INSTRUMENTATION -----	13
General -----	13
Transmitter (SX-7) -----	13
Receiver (SX-7) -----	14
Transmitter/Receiver (SX-8) -----	14
Filter Amplifier -----	15
Waveform Digitizer -----	15
Control Computer -----	15
Data Printer -----	18
X-7 Plotter -----	18
Control Module -----	20
Winches -----	20
IDAHO SPRINGS, COLORADO -----	23
Site Description -----	23
Field Activities -----	25
Representative Data -----	30
Tunnel Detection -----	37
Tunnel Location -----	43
Pulse-echo Sonar -----	48
Velocity Determinations -----	48
MANATEE SPRINGS, FLORIDA -----	49
Site Description -----	49
Field Activities — 1980 -----	49
Field Activities — 1981 -----	53
Representative Data -----	54
Cavity Detection -----	57
Cavity Location -----	62
CONCLUSIONS -----	65
RECOMMENDATIONS -----	67
APPENDIX A   V <sub>p</sub> V <sub>s</sub> Determinations — Idaho Springs, CO	
APPENDIX B   Sonar Logs — Idaho Springs, CO	
APPENDIX C   Sonar Logs — Manatee Springs, FL	

## TABLE OF FIGURES

	Page
1. Before and After Surveys-----	3
2. Signal Delay Caused by Tunnel-----	6
3. Tunnel Reconnaissance Procedure-----	7
4. Tunnel Location Procedure-----	8
5. SX-8 Signal Record-----	9
6. Horizontal Beam Pattern — SX-8-----	11
7. Block Diagram of SX-7 Borehole Sonar-----	12
8. Typical SX-7 Probes-----	15
9. Prototype SX-7-----	17
10. Graphics Plotter Output-----	19
11. Typical Crosshole Data Record-----	21
12. Idaho Spring Test Site Borehole Layout-----	22
13. Crosshole Surveys Between Holes 6 and 7-----	24
14. Common Depth and Vertical Offset Patterns-----	32
15. Comparison of Tunnel Anomaly With Normal Data-----	33
16. Fan Patterns-----	34
17. Pre Tunnel Fan Data-----	35
18. Post Tunnel Fan Data-----	36
19. Tunnel Detection by Borehole Sonar-----	38
20. Tunnel Detected Through Ten Meters-----	39
21. Tunnel Detected Through Fourteen Meters-----	40
22. Tunnel Detected Through Twenty Meters-----	42
23. Vertical Offset Crosshole Data-----	44
24. Vertical Offset Method of Tunnel Location-----	45
25. Location and Cross Section of CSM Tunnel-----	46
26. CSM Tunnel Located Through Twenty Meters-----	47
27. Borehole and Cavity Map — Manatee Springs-----	51
28. Crosshole Section C3 to C4-----	52
29. Crosshole Sections C2 to C3 and C2 to C5-----	53
30. Composite Section C3 to C4-----	55
31. Composite Data from C1 to C5, C2, C3 and C4-----	56
32. Crosshole Sections C2 to C3-----	58
33. Crosshole Sections C2 to C5-----	59
34. Crosshole Section C3 to C4-----	60
35. Crosshole Section C3 to C4 — Enlarged-----	61
36. Cave Location by Borehole Sonar-----	63

## LIST OF TABLES

	<b>Page</b>
1. Borehole Collar Elevations — Idaho Springs-----	23
2. Idaho Springs Test Site Data Files — 1980 Pre Tunnel-----	26
3. VpVs Data Files-----	27
4. Idaho Springs Test Site Data Files — 1981-----	28
5. Manatee Springs Test Site Data Files — 1980 & 1981-----	50

## ABSTRACT

Tunnel and cavity detection are of paramount importance for security and construction requirements. The development and implementation of tools for detection is being sponsored by the Department of the Army to fulfill many of these needs.

Borehole sonar, using equipment by SONEX, was used at two sites, Idaho Springs, Colorado and Manatee Springs, Florida, to detect and locate a manmade tunnel, and a water-filled cave. Crosshole sonar techniques were used with the receiver and transmitter in separate holes separated horizontally by 20 to 89 feet and vertically by 0 to 20 feet.

The results demonstrate that even under poor conditions the SX-7 borehole sonar can be used to reliably detect, locate, and define tunnels between holes spaced up to 65 feet (30 meters) apart. Under normal or optimal conditions, detection up to 100 feet or more should be possible. Water-filled caves are detectable, and in the one example seen, a distinctive signature was noted.

Further experimentation is desirable to develop characteristic signal signatures for differing rock conditions and tunnel or void-fill materials. Additional development for tuneable sonic sources is warranted to achieve optimum penetration without losing target resolution. Additional resolution in cavity and void mapping can be gained by holographic processing of the phase-shifted crosshole signals. Research into implementation of this should be considered.

In summary, the SX-7 borehole sonar is well-suited now for field use in detecting and mapping tunnels, caves and similar targets, and could be immediately deployed in the field. Additional development could increase both the detection and the resolution.

## **Preface**

This final report, prepared for the Mobility Equipment Research and Development Command, covers a demonstration of the SONEX SX-7 borehole sonar for tunnel and cavity detection.

The work was performed under Contract No. DAAK70-81-C-0241, and was performed solely by SONEX of Richland, Washington. SONEX is the manufacturer of the SX-7, and provides sales of the equipment and of services associated with the equipment.

We would like to express our thanks to the staff of the Geophysics Branch of MERADCOM for their support in the conduct of this program, especially to Mr. Ray Dennis and Mr. Don Granahan for their support in the field; and to Mr. Stafford Cooper and Mr. Bob Ballard of the Corps of Engineers, Waterways Experiment Station, for their invaluable assistance.

## INTRODUCTION AND SUMMARY

The ability to detect underground cavities is critical to safe and successful operations in several areas of national importance. This ability is critical to defense when the cavities are military infiltration tunnels such as those the North Koreans drove through the demilitarized zone. It is critical to the energy program when the cavities are natural or man-made faults that affect the integrity of a nuclear power plant site. It is critical to safety when the cavities are abandoned coal mines that disrupt or destroy new mining operations if encountered unexpectedly. Without a fully developed ability to detect underground cavities, our nation faces possible breaches of security, human injuries and fatalities, and economic losses. Without this ability, it faces the possibility of another disaster such as the Teton Dam collapse in the mid-70's, which may have been caused by an undetected cavity or cavity system.

Because of the severity of the potential impact to safety and the national economy, many agencies of the federal government have initiated programs to develop or discover adequate cavity-detection methods. One continuous effort has been fielded by the United States Army. Research, development, and experimentation have been funded by the Mobility Equipment Research and Development Command (MERADCOM) at Fort Belvoir, Virginia, and the Corps of Engineers, Waterways Experimental Station (WES) at Vicksburg, Mississippi, among others.

In 1980 and 1981 we were privileged to conduct a series of tunnel and cavity detection demonstrations for MERADCOM and WES. The equipment used was the SX-7 Borehole Sonar operating in the crosshole mode. This report summarizes the results of the demonstrations and includes data presented in February 1981 covering the 1980 tests.

Two very different types of anomalies were studied. The first, at Idaho Springs, Colorado, was a man-made tunnel, roughly 8 feet by 8 feet, in faulted and fractured hard-rock. The 1980 tests were conducted before the tunnel was constructed. The 1981 tests were conducted after the tunnel was constructed using the same boreholes as used in 1980. This provided a definitive demonstration of the SX-7 capabilities for tunnel detection. Experiments were also conducted with various probe combinations. P-wave and S-wave velocities were calculated, to the degree possible, between pairs of holes.

The second anomaly, at Manatee Springs, Florida, was a water-filled cave in a low density marlstone. The location and size of the main cave were estimated by divers. The tests showed the response from a water-filled anomaly in a rock with a sonic velocity very close to that of water. The capability to transmit over long distances and detect the presence of a cavity was demonstrated.

The demonstrations for MERADCOM and WES were conducted with the SX-7 crosshole sonar. In each demonstration, the goals were to establish

- that sonic energy can be transmitted and received over moderate distances under non-ideal rock conditions, and
- that the resultant crosshole signals can be used to determine the presence of a cavity between the two holes and, in some degree, to describe the shape and location of the cavity.

Neither Manatee Springs, Florida, nor Idaho Springs, Colorado, provided what would be considered ideal — or even normal — conditions for crosshole sonar, which operates best in a hard-rock environment.

In normal rock, the velocity of the sonic pressure waves ( $V_p$ ), used as an indicator of rock density, typically ranges from 15,000 to 20,000 feet per second (fps). If all other conditions are the same, higher rock

density is accompanied by higher sonic velocity and better signal transmission. In contrast, the apparent  $V_p$  observed at Idaho Springs ranged from 7,600 fps to 13,000 fps, and the apparent  $V_p$  observed at Manatee Springs was even lower, ranging from 6,000 fps to 9,000 fps except for a thin, hard layer near the Ocala-Williston contract, where a distinctively high  $V_p$  of about 15,000 fps was observed. In spite of the poor transmissibility, useful tunnel or cavity detection data was obtained over reasonable distances, up to 20 meters at Idaho Springs and up to 89 feet (27 meters) at Manatee Springs.

### **Idaho Springs, Colorado**

At Idaho Springs a tunnel was driven as a control target for tunnel identification tests. Six holes were drilled; a line of four holes bracketing the planned tunnel centerline, and a pair of holes to the east of the line also bracket the tunnel. However, one of these could not be used for sonic tests.

Again, there were two primary tasks. The first was to test the ability of the borehole system to operate in broken rock. The second was to provide background sonic data prior to tunnel construction so that they can be compared with data taken in an identical manner after the tunnel passes the line of boreholes. This would provide positive proof that the tunnel itself is the cause of the sonic anomaly.

The tests were successful. A good set of baseline data was recorded in 1980 for comparison with the "post-tunnel" data. The major difficulties encountered were keeping the holes water-filled and a mine-noise level that prevented the use of the low-frequency end of the sonic range.

Transmission was readily achieved in 1980 between pairs of holes spaced nominally 10 meters apart (holes No. 6 and No. 7, and holes No. 7 and No. 8). Transmission was also successful through 20 meters of rock from hole No. 6 to hole No. 8. Transmission was unsuccessful through 20 meters of rock from hole No. 7 to hole No. 5. One cause for the lack of success was the apparent increase in noise whenever the receiver probe was in hole No. 5. Further, it was impossible to keep this hole filled with water; the available water supply was exhausted in about 90 minutes.

The baseline survey was conducted from a depth of 142 feet to 181 feet using holes No. 6 and 7. The centerline of the tunnel passes between these holes at a depth of about 160 feet. The comparison of the pre-tunnel baseline survey and the post-tunnel survey conducted in 1981 provides the best data ever obtained on the response of the borehole sonar system to a man-made cavity.

In 1981 the stations of the baseline survey were reoccupied, and a new set of data, the post-tunnel data, was recorded. *Figure 1* shows the comparison of the baseline survey data from 1980 (1A) and the post-tunnel data from 1981 (1B). The loss of signal in the section from 157 to 166 feet deep (seen in 1B) is consistent with what is expected from an air-filled cavity.

Further surveys using offset transmitter and receiver locations enabled us to define the center point of the tunnel anomaly, and to define the outer boundaries of the anomaly. These conform well with the mapped tunnel location.

After the comparison data was taken, a set of crosshole data was taken between all pairs of holes to derive P-wave and S-wave velocities at one-half foot intervals throughout the holes. Six pairs of holes were evaluated. The data is presented in the appendix and discussed in the section entitled *Velocity Determinations*.

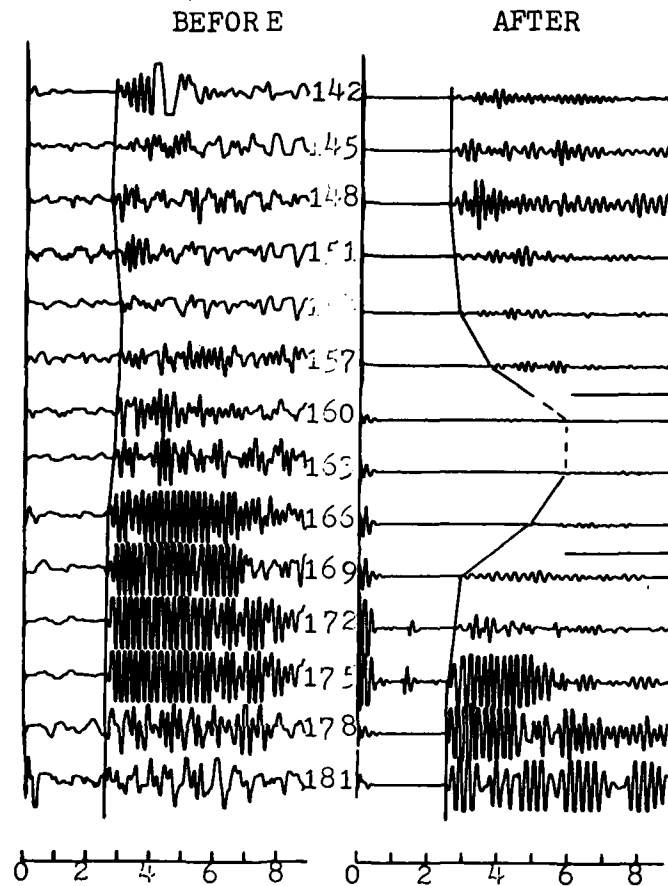

Figure 1. **Before and After Surveys** of Holes 6 and 7 showing the effect of the tunnel in the AFTER survey. Signal amplitude is down. Signal arrival time is delayed. Note the effect of the distressed halo around the tunnel, 151-157 and 169-171. Tunnel height can be estimated directly from the AFTER data, about 9 feet.

Experiments were conducted successfully demonstrating two newly-designed transmitter probes. In one new probe the size and shape of the spark chamber was changed. The chamber is larger than the original chamber. Received signal comparisons — in air — indicate that the new chamber, used with the original electronic section, is approximately five times as energetic. The second probe tested is smaller than the original and is designed to fit into a two-inch diameter hole. This required a redesign of the probe electronics. The redesigned electronics appear to be approximately twice as energetic as the original probe.

Experiments with a piezoelectric transmitter, operating at high frequencies (22 kHz) showed that the nature of the rock at Idaho Springs was such that we could not penetrate 10 meters. In similar tests in a dense limestone in Honduras we were able to receive good signal levels through 30 meters with the same system. Because of the reduction in transmission range the SX-8 pulse-echo sonar did not provide useful tunnel location data.

All data from all tests were recorded on magnetic diskettes during the field tests. Copies of the diskettes were given to MERADCOM. Data files were also copied to digital tape cassettes and given to MERADCOM.

### ***Manatee Springs, Florida***

The demonstration and experiments at Manatee Springs were designed around an existing cave system in sedimentary rocks. Four test borings were drilled in line perpendicular to and straddling the axis of one arm of the cave system. A fifth boring was drilled some 70 feet to the side of the line. There were two primary tasks. The first was to test the ability of the borehole system to operate in low-density rock. If adequate signal transmission could be obtained, the second task was to test the ability of the system to indicate the presence of the cave.

Both tasks were completed. Good signal transmission was achieved through an intervening distance of approximately 89 feet between holes C4 and C1. The ability to detect the presence of a cave was clearly demonstrated.

At the time of the 1980 field investigation, the cave between holes C2 and C3 was believed to extend vertically from a depth of about 105 feet to about 115 feet. Reviewing the records of the crosshole survey, it was seen that the sonic signal almost disappeared in the 106- to 120-foot deep range. Because of this coincidence between the expected anomaly position and the signal response — and because all crosshole surveys to that time had been conducted in rock with sonic velocities much greater than the sonic velocity of water — it was assumed that the reduced signal transmission indicated the presence of a cave.

Additional information received in January 1981 showed the cave to be much higher, starting at a depth of 91 feet and extending to 107 feet. Re-examining the records, strong signal transmissions were noted in this interval. The assumption was that the water-filled cave is a better transmission medium for sonic energy than the surrounding rock, and the amount of signal energy reflected or scattered at the boundaries of the cave is inconsequential. Unfortunately, because of the assumed cave location most of the 1980 investigations were conducted starting at a depth of 100 feet and going down to 120 feet. The main zone of interest received only a cursory look. For this reason, additional tasks were conducted in 1981. A more detailed study was made of the vertical interval from 80 to 120 feet. Crosshole data from C4 to C5, from C3 to C2, and from C2 to C5 were compared to see if a signature can be recognized for a water-filled cave.

The additional data confirmed that the water-filled cavity has a recognizable signal. The signature can be easily recognized in the close spaced pairs of holes, and can be seen even where the holes are up to 85 feet apart. Offset crosshole surveys were used to plot the limits of the cave location which correspond closely to the cave cross-section mapped by divers. An indication of a second cave area between C3 and C4 was seen.

## TECHNIQUES

### **Borehole Sonar**

Density anomalies in rock can be located by the use of sonic energy. **Borehole Sonar by Sonex** provides a means of investigating rock and concrete masses. Cavities, voids, cracks and fractures, as well as changes in material density and sonic velocity, can be detected. Applications include tunnel and cave detection, concrete inspection, open pit blasting, oil well location and geologic mapping.

The word SONAR (SOund Navigation And Ranging) was coined in the early 1940's to describe the British invention that used sonic beams for undersea target detection. The original sonar devices used arrays of Rochelle salt crystals, or quartz crystals as the piezoelectric elements (transducers) that transformed electrical pulses into mechanical pulses generating sound waves. The sonic beams reflected from targets (ships, U-boats, shoals, etc.), and in striking the transducers created electrical pulses which were recognized as the target signals.

The time elapsing between the initiation of the sonic pulse and the reception of the target signal could be accurately measured. The nominal velocity of sound in water was known to be about 1500 meters per second so the distance to the reflecting target could be accurately determined. The target bearing could be determined by rotating the transducer array to get the strongest possible reflected target signal.

Crosshole sonar (**Sonex SX-7**) is used to interrogate from hole to hole. As the transmit and receive probes are raised up the holes the sonic velocity and amplitude are noted. These can be used to quickly and easily infer the relative density of the material. In general, the higher the sonic velocity, the higher the density of the transmission medium. This technique is especially valuable when planning drill-and-blast patterns in large open-pit mining operations. Significant savings in drilling time, explosives useage, and reduced secondary blasting costs can be achieved.

The ability to detect density changes makes the SX-7 an ideal tool for cavity, void, and tunnel detection. The absence of rock in the cavity or tunnel represents a major reduction in density. The sonic signal is greatly delayed. The cavity or tunnel walls represent significant impedance mismatches which reflect and scatter large portions of the sonic energy. The received signal is thus greatly reduced in amplitude as well as being delayed in arrival.

The SX-7 can interrogate between holes up to fifty meters apart to determine the relative sonic velocity of the intervening material. The maximum allowable hole spacing is established by the sonic transmissibility of the media, the desired target resolution and the sonic transmitter used with the SX-7. Proper understanding of these variables is necessary for successful application.

Pulse-echo sonar (**Sonex SX-8**) is more directly analogous to ocean sonar. Transmission and reception take place at the same location. Only one borehole is required. The SX-8 uses the reflected sonic energy to detect and locate targets in the rock. Any change in rock density or elasticity can create a reflecting surface. The directionality built into the SX-8 probe allows us to determine target bearing. Distance to the target is determined as the sonic velocity times the elapsed travel time.

The SX-8 lends itself to detection of targets when it is impractical to drill multiple holes. Relative rock density and the degree of fracturing can be estimated. Targets such as lost oil wells, caves and ore veins can be mapped. The SX-8 can see one hundred feet or more from the borehole location under optimum conditions. Wells over 10,000 feet deep can be used.

### Crosshole Sonar (SX-7)

The **Sonex Crosshole Sonar (SX-7)** uses two sonar probes, one to transmit and one to receive sonic energy, and can be used to determine sonic velocities between pairs of holes. The SX-7 can therefore be used to detect anomalies in the crosshole sonic velocities, and changes in sonic velocities over a period of time. Thus the SX-7 becomes a useful tool for geologic investigation for cavities, fractures and other phenomenon which affect the crosshole sonic velocity. In the crosshole mode the SX-7 looks for the first arrival of a signal from hole to hole. This signal will have traveled by the fastest path (usually the most direct path) from the transmitter to the receiver. The travel time (T) can be accurately determined, and the distance (D) is known. Knowing T and D we can calculate the sonic velocity (V):  $V = D/T$ .

Usually we would expect the pressure wave component of the signal to arrive first, so V would be  $V_p$ . Another sonic velocity component is  $V_s$ , the shear wave. In seismic terms, velocity is usually expressed in feet per second or meters per millisecond. Throughout this report,  $V_p$  and  $V_s$  will be presented in feet per second (fps).

Now that we have a separate receiver and transmitter and can determine sonic velocities, we can use this crosshole sonar mode to determine sonic velocity anomalies or changes in sonic velocity over time. If we know that  $V_p$  for a given section or a given geologic formation is 20,000 fps, we would expect that a signal traveling between two boreholes 100 feet apart would take 5 milliseconds.

$$T = D/V_p$$

$$T = 100 \text{ ft}/20,000 \text{ fps} = 0.005 \text{ seconds} = 5 \text{ milliseconds}$$

If the signal takes a significantly longer time, say 6 milliseconds, we can infer that a reduced sonic-velocity zone is present somewhere between the receiver and the transmitter.

The crosshole method and the SX-7 probes were the primary tools used in the cavity detection evaluation program at Idaho Springs and at Manatee Springs. As shown, a low velocity material between two boreholes will delay the travel of a sonic signal between the holes.

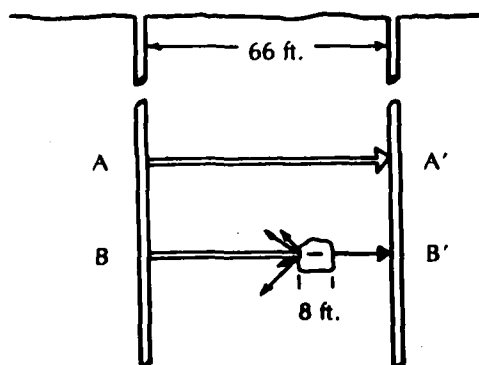

A-A': THROUGH 66 FEET OF ROCK  
( $V_p = 13,000 \text{ fps}$ )

$$T = 66 + 13,000 = 5.1 \text{ msec}$$

- NO TUNNEL

B-B': THROUGH 58 FEET OF ROCK  
AND 8 FEET OF AIR  
( $V_p = 1,100 \text{ fps}$ )

$$T = (58 + 13,000) + (8 + 1,100) = 11.7 \text{ msec}$$

- PROBABLE TUNNEL

**Figure 2. Signal Delay Caused by Tunnel.** This example shows the degree of signal delay which can be caused by a typical tunnel. The delay-deviation from normal depends on the ratio of tunnel size to hole spacing, and the ratio of normal rock sonic velocity to the sonic velocity in air (or water if the tunnel is water-filled).

The granitic rocks at Idaho Springs have  $V_p$  values ranging from 8,000 to 13,000 fps. The air in the tunnel has a nominal  $V_p$  of 1,100 fps.

Rock = 13,000 fps

Air = 1,100 fps

Figure 2 shows the time calculations for the air-filled tunnel. An eight-foot-wide tunnel between two boreholes 66 feet (20 meters) apart changes the sonic signal travel time from 5.1 ms to 11.7 ms, greater than twice the normal time. Above or below the tunnel the normal  $V_p$  travel time will be noted.

Figure 3 shows how the SX-7 is used to detect a tunnel. The transmitter probe and the receiver probe are placed in their respective holes, separated by a known horizontal distance, and at the same elevation. As they are raised or lowered together in the holes the crosshole sonic signals are recorded. The effects of changes in the geologic material will cause some slight differences in the observed arrival times, but if a tunnel is present the observed arrival time will change significantly as calculated in Figure 2 and shown clearly in Figure 1.

The height of the tunnel may be estimated by measuring the vertical distance between the mid-points as the upper and lower slopes of the signal delay curve. In Figure 1 this estimated distance is nine feet. Since the data were recorded at three foot intervals the vertical resolution is  $\pm 3$  feet.

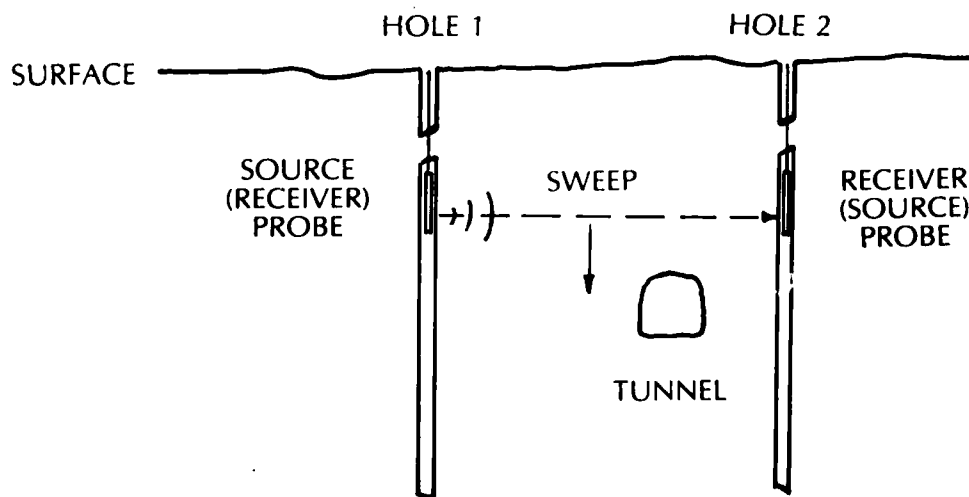

Figure 3. **Tunnel Reconnaissance Procedure.** Downhole surveys are used to detect arrival-time anomalies in through-transmission mode with the SX-7 crosshole sonar. The transmitter and receiver are kept at equal elevations as they traverse the holes. This type of survey can be run and the data recorded at the rate of about two vertical stations per minute with the SX-7.

Figure 4 shows the method used to locate the tunnel horizontally between the holes after it has been detected using the common-depth survey. The upper and lower limits of the anomaly are determined by taking the mid-point of the delay slope as an estimated point. The transmitter is positioned at the mid-point of the detected anomaly.

The receiver is then placed several feet above the transmitter and lowered through the anomalous zone, noting when the signal arrival time is changed. This procedure is then repeated with the receiver placed in the center of the zone and the transmitter moved vertically. In this manner it is possible to estimate the horizontal location of the tunnel.

Another method is to offset the receiver and transmitter by some known distance and then raise them together keeping the same vertical offset. Again the tunnel can be seen by the signal delay caused by the lower sonic velocity. The receiver should be positioned above the transmitter in some series and below the transmitter in some for best definition. The maximum offset used is dependent upon the system's ability to transmit through the medium. In any event, maximum offset should be no less than the anomaly height.

These crosshole patterns can be repeated to derive very detailed size and location information. These data may be interpreted through holographic or tomographic methods using high-speed computers with large memory capacity or floating point array processors. This amount of data is not always necessary for tunnel detection and location. Visual examination and hand plotting of selected data is often sufficient.

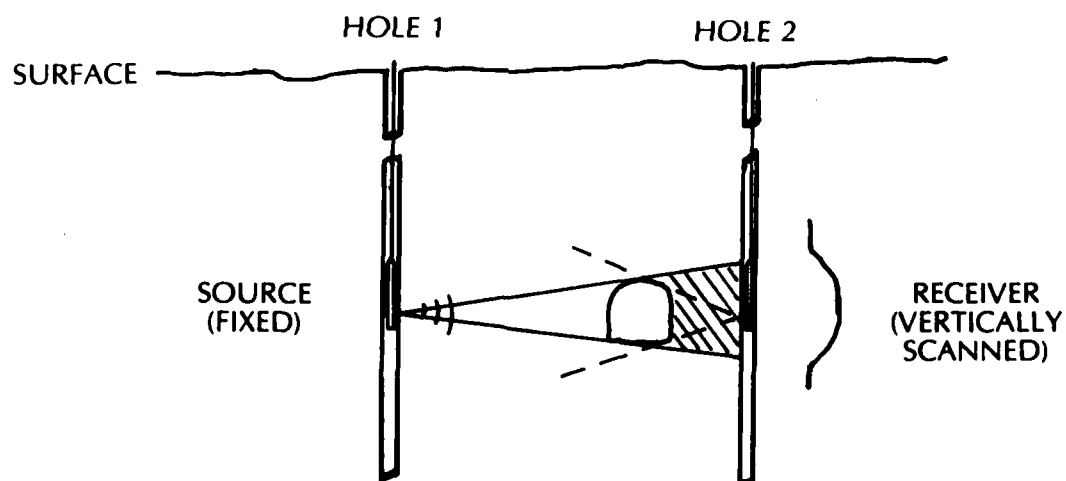

Figure 4. **Tunnel Location Procedure.** First-arrival measurements are obtained at vertical increments in order to obtain detailed information about the scattered wavefront. One probe is held stationary and the other scanned along the hole. The "shadow" of the anomalous zone, shown as a signal delay deviation, defines the limits of the shape and location of the anomaly cross-section. Many of the scanned "fan patterns" can be recorded as seen in Figure 6C.

### **Pulse Echo Sonar (SX-8)**

The **Sonex SX-8 Pulse Echo Sonar** is directly analogous to ocean sonar devices. The SX-8 transducers which generate and detect the sonic signals are piezoelectric ceramic elements similar to those in use on some present-day sonar devices. The signals are transmitted through rock instead of through water, and the targets are other boreholes, cavities, veins, faults and similar features; but the principles are the same. Reflected sonic pulses strike the receiver transducer and are transformed into electrical pulses with some recognizable frequency and amplitude characteristics.

The elapsed time between signal initiation and signal reception can be measured to hundredths of a millisecond. If the velocity of sound in the specific rock mass is known, the distance to the reflector can be accurately calculated. The transmitters and receivers of the SX-8 system are designed to be directional. The transducer probes can be rotated in the hole to determine the bearing to the target by optimizing the signal amplitude.

A typical pulse echo record is seen in *Figure 5*. The full scale across the record is equivalent to 50 feet. Full time scale equals 5ms; the  $V_p$  of the rock equals 20,000 fps; thus full scale travel equals 100 feet (out and back), or 50 feet one way, to the reflecting surface.

Each pulse on the record is a signal received by the receiver, however, because of the complexity of the geologic environment these are not all primary reflected P-waves. Some are S-waves, some are reverberations of primary signals, some are refracted signals, and some are signals from within the holes. The SONEX CAGE (Computer Assisted Geologic Evaluation) program must be used to interpret the data fully for geologic logging.

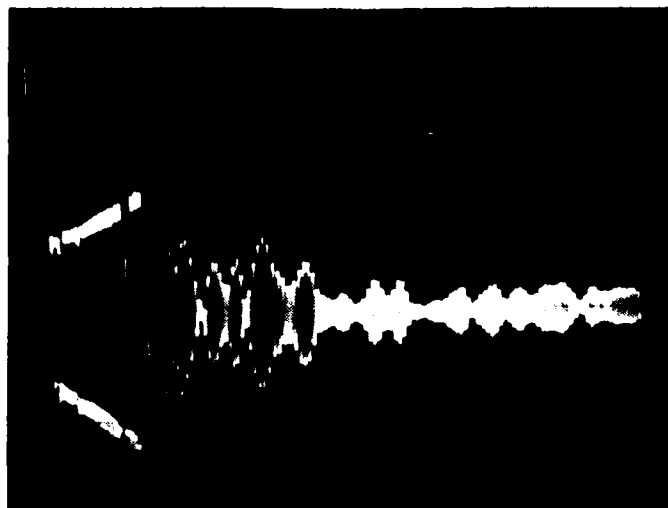

*Figure 5. SX-8 Signal Record. Full scale equals five milliseconds.*

The measured directional pattern of a pulse-echo probe is shown in *Figure 6*. The transmitter propagation pattern is shown as a solid line. The receiver sensitivity pattern is shown as a dashed line.

It is possible to use the SX-8 generated data without computer interpretation when the targets being sought are discrete, well defined features such as boreholes, tunnels, faults and cavities. In such cases a visual inspection of a section of the raw data can often locate the target.

An obvious advantage of the pulse echo method is that one can look out in any direction from the search hole. It is not necessary to have a receive hole in the search plane. The limitation is that one must analyze the data much more thoroughly, thus there is a greater risk of overlooking a target.

An optimum program calls for the use of both methods. The crosshole method can be deployed quickly, and analyzed quickly, in the field, for a reconnaissance tool. In areas where targets such as cavities are seen, or their presence is suspected, or in areas where target detection is more critical, the pulse echo may also be used to extend the area surveyed. Equipment used in both of the borehole sonar systems is more fully described below.

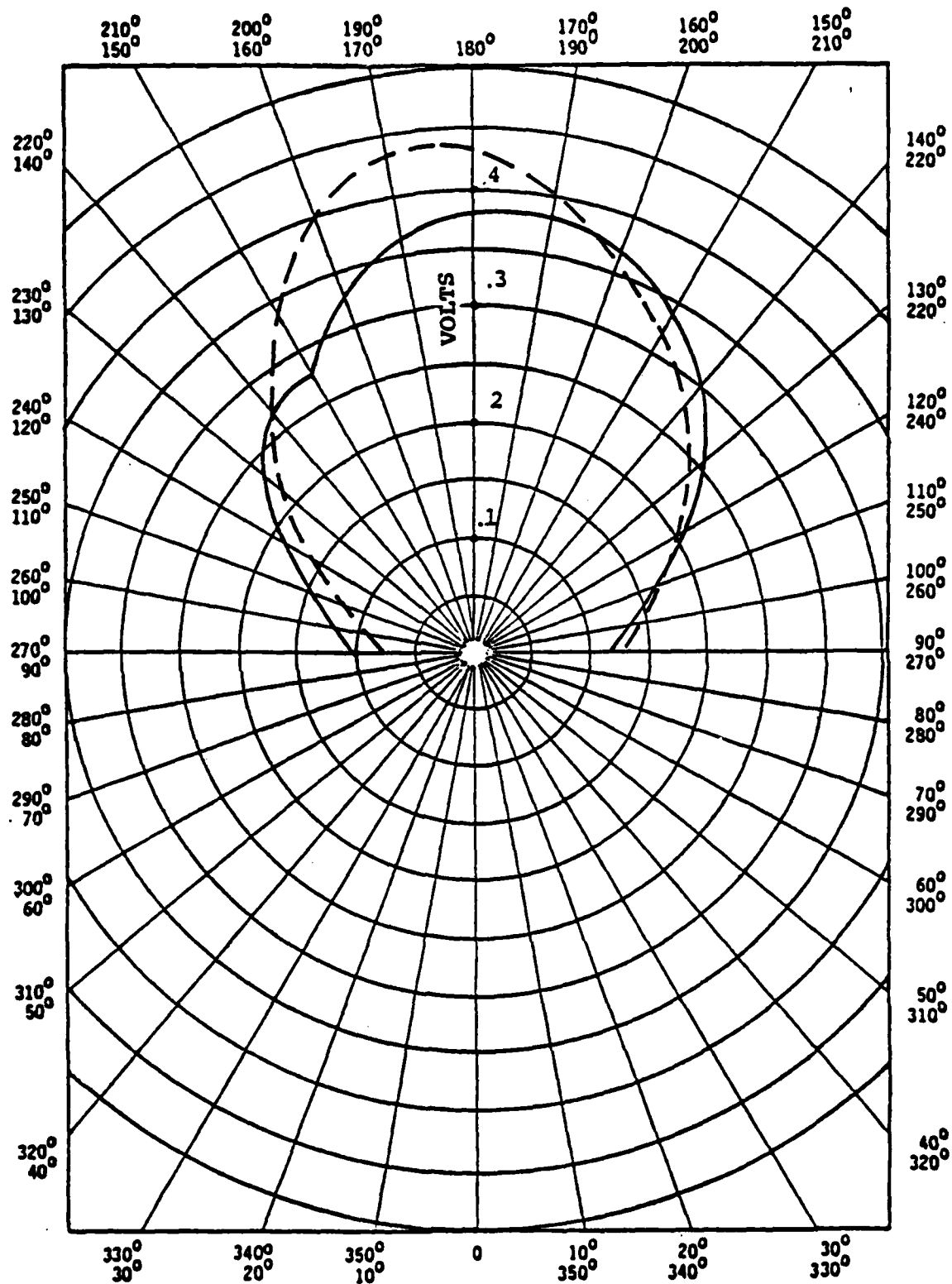

Figure 6. **Horizontal Beam Pattern—SX-8.** Directional 25-kHz PZT transducer in a concrete medium. Horizontal separation between the two elements is 120 inches.

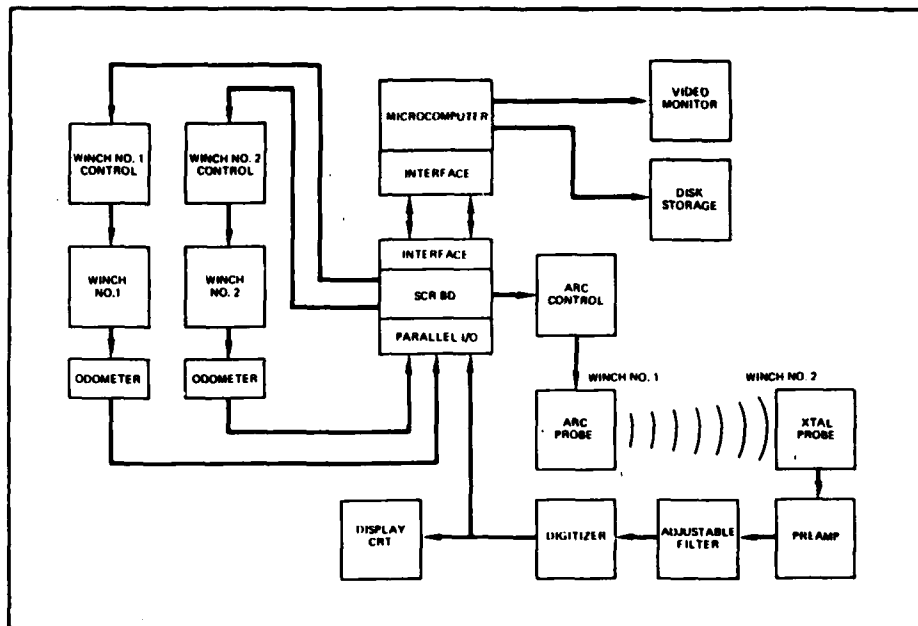

Figure 7. **Block Diagram of SX-7 Borehole Sonar.** The microcomputer (top, center) is the control center of the system, running the winches to position the probes, receiving and displaying the crosshole signals, and storing the data for permanent record. the ARC PROBE is an SX-117 transmitter probe; the XTAL PROBE is an SX-114 receiver probe. The DISPLAY CRT (lower left) is an optional device not required for normal operation.

## INSTRUMENTATION

### **General**

The SONEX Borehole Sonar equipment is field rugged. SONEX equipment is designed for field use under severe environmental conditions. Systems have been used from arctic conditions to subtropical humidity, at elevations ranging from 280 m. below sea level in Hokkaido (Japan) to 3900 m. above sea level in Colorado (USA).

The equipment is easy to ship. When the system is packed for shipment (with all the necessary peripherals, spare parts, test equipment and tools) the SX-7 and SX-8 together weigh less than 500 Kg. Equipment can be readily transported by air using commercial air freight services. On land it can be transported, and operated, from a nine passenger van, pickup truck, or similar vehicle.

The borehole sonar does not require special power considerations. The power requirement is for 2KW of 110 VAC. Typically a 3KW or larger generator is used in case the generator is downrated by less than optimum operation. The system can accept normal power level fluctuations. Each module has a separate regulated power supply.

A borehole sonar system can be considered as consisting of three functional subsystems:

1. Signal transmit and receive probes
2. Data control, display and recorders
3. Probe winches and winch controls

A block diagram of the crosshole sonar (SX-7) system is shown in *Figure 7*. The transmit and receive probes are shown in the lower right. The probe winches and winch controls are shown on the left. The remainder of the diagram represents the data control, display and recorders segments. The major difference between the SX-7 and the SX-8 as far as the block diagram is concerned is that the SX-8 would show only one probe.

The tests conducted at Idaho Springs, Colorado, and at Manatee Springs, Florida, used the crosshole sonar mode. The transmitter was a high-energy, low-frequency sonic source; the receiver was a broad-band piezo-electric ceramic element. Each unit was built into a downhole probe that operated on a four-conductor armored steel cable. Two computer-controlled winches moved the probes to the desired vertical positions. A small commercial computer with custom software and hardware provided control of the winches and stored the received signal data on magnetic diskettes. The same computer was used to recall and plot the data on an X-Y plotter or on a graphic printer. A commercial transient-waveform digitizer and an adjustable filter were used to condition the amplified receive-signal prior to display and storage.

### **Transmitter (SX-7)**

A proprietary-design spark-generating transmitter was used for the sonic source in the demonstrations. The sonic signal was generated by discharging a stored electrical charge through an electrolytic fluid in a chamber of the probe. This spark discharge provided a high energy output at a relatively low sonic frequency.

The output frequency is largely a function of the physical design of the spark chamber. On the probe used in the borehole demonstrations, the spark chamber produced a wide-band pulse in the 0.5 to 8.0 kHz range, apparently centered around 4 kHz. It is difficult to calculate the output frequency spectrum more precisely because there is some effect from the transmit and receive borehole sizes, the nature of the intervening rock, and the frequency characteristics of the receiving transducer and amplifiers.

In operation, a charge of 1,500-2,000 volts is stored in the downhole probe and discharged through a relay upon command from the surface. This method provides a crisper, sharper pulse of energy than techniques that store the charge at the surface and discharge through long connecting cables. The probe can be used at great depths — over 10,000 feet — with essentially no change in the shape or strength of the sonic pulse. Surface-generated spark devices usually are limited to a few hundred feet of cable; beyond that length, cable impedance degrades the pulse to the point of uselessness. Experiments with the size and shape of the spark chamber showed that the frequency and peak power output can be improved by improved design.

The sparker probe is 2.5 inches in diameter and 9 feet long. Its weight in air is nominally 60 pounds. It is fitted with a Gearhardt-Owens type head, which can be used to mate with most standard four-conductor armored logging cables. The sparker and receiver can be interchanged on either support winch cable.

#### **Receiver (SX-7)**

The borehole sonar receiver probe consists of a lead-zirconate-titanate (PZT) piezoelectric ceramic element and a two-stage audio-frequency amplifier. The transducer has a nearly flat reception response from 1 to 10 kHz.

The two-stage audio frequency amplifier is a proprietary design that provides high noise rejection and 64-db amplification in an extremely low-noise circuit. The amplifiers are designed to operate under high heat conditions if necessary.

The probe is 1.25 inches in diameter and 4 feet long. It weighs less than 10 pounds in air. For deep hole applications, or holes with high-viscosity fluid filling, a sinker bar or outer shell is used to increase the weight. Typical transmitter and receiver probes are shown in *Figure 8*.

#### **Transmitter/Receiver (SX-8)**

The SX-8 probe contains a single sonar element which acts first as the transmitter, and then as the receiver. This dual purpose transducer is built to a proprietary design for Sonex. The PZT ceramic elements are designed to be narrow-band, operating at nominally 22 kHz.

In the transmit mode the transducer can be driven by a 700-volt spike pulse triggered from the surface module, or it can be driven by a 22 kHz input signal which can be varied from 3 to 10 cycles in duration. The receiver contains filter and amplification circuitry similar to that in the SX-7 receiver probe.

The active probe element is acoustically shielded so that the transmit beam and receiver sensitivity are both directional. *Figure 6* in the previous section shows the achieved directionality with one SX-8 probe design.

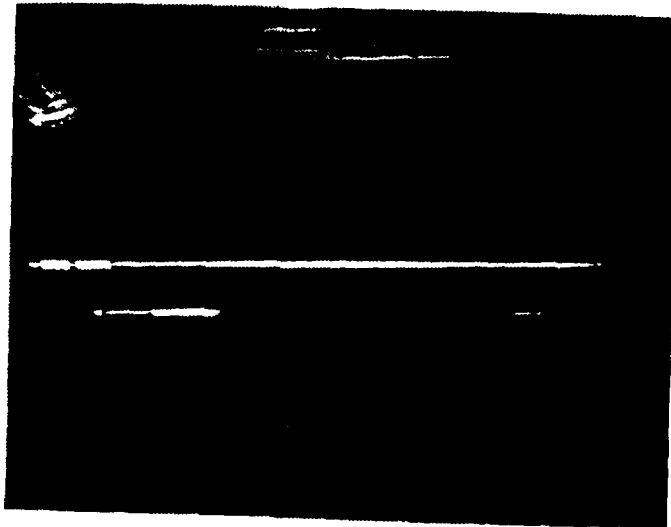

- A) **Spark Transmitter Probes.** The smaller sonde was assembled to work in undersized holes. The large sonde is 2-5/8" maximum diameter, the small sonde is 2" maximum diameter.

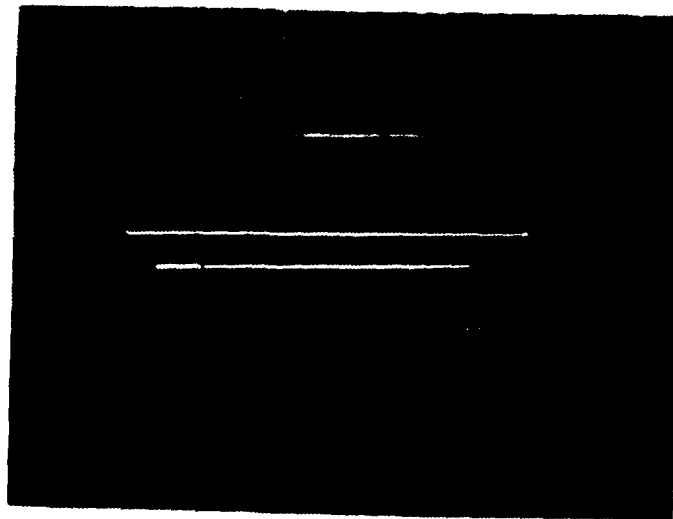

- B) **Receiver Probes.** 10 kHz and 22 kHz. Each is less than 2" maximum diameter. For scale the floor tiles are 10" square.

Figure 8. **Typical SX-7 Probes**

### **Filter Amplifier**

The detected amplified signal is transmitted up the logging cable, through the slip rings, and input to a ITHACO 4213 Electronic Filter. This module provides selectable band-pass filtering and an additional 40-db signal amplification. The filtered signal is output to the waveform digitizer.

### **Waveform Digitizer**

A Biomation 805 Transient Waveform Recorder is used to digitize and hold the analog signal train. The signal is sampled and digitized at 2,048 points. In a nominal 10-millisecond signal train, each digitized point represents about 5 microseconds.

The waveform digitizer also provides nine levels of selectable signal attenuation, from 0.1 to 50 in 1-2-5 sequence. This attenuation is used to keep the amplified signal within the limits of the digitize, record, and display system capabilities.

The digitized signal can be displayed immediately on a cathode ray tube (CRT) storage monitor. The signal is also output from the digitizer to the control computer on command from the computer.

### **Control Computer**

A small, commercially available computer (Apple II with 48-k RAM and two diskette drives) was adapted to provide a means for operator input, logging function control, and signal data storage. Proprietary software and hardware were developed to dedicate the Apple II to this purpose.

The basic computer program first requests the operator to define the starting elevations of the two winch-supported probes. Then, the operator is asked to what depth the probes should be moved for the survey, and the computer automatically runs the winches until the proper elevations are reached.

At the start of each logging sequence the operator inputs the data file identifying the number, the date, and the digitized sample time interval. He also instructs the computer how far each probe should be moved between crosshole sonar measurements. It is possible to move both probes an equal distance (e.g., five feet) simultaneously; or one probe can be held stationary while the other is moved. The speed at which the probes are moved is set on the winch-control panel and can be controlled from 0 to nominally 20 feet per minute.

When the two probes are properly positioned according to the instructions given to the computer, the computer arms the waveform digitizer to accept one signal-data string. Then, the operator is advised that the system is ready, and he manually fires the spark probe with a panel-mounted pushbutton.

The received and digitized signal data are displayed immediately on the CRT storage monitor, are written out to diskette storage by the computer, and are then displayed as computer output on a small video monitor. At this point, the operator can accept or reject the signal. This option is included so that he can adjust the filter amplifier systems to compensate for changing rock conditions if necessary.

If the operator accepts the record, the computer instructs the winches to move the probes to the next data-taking position. If the record is rejected, the operator can:

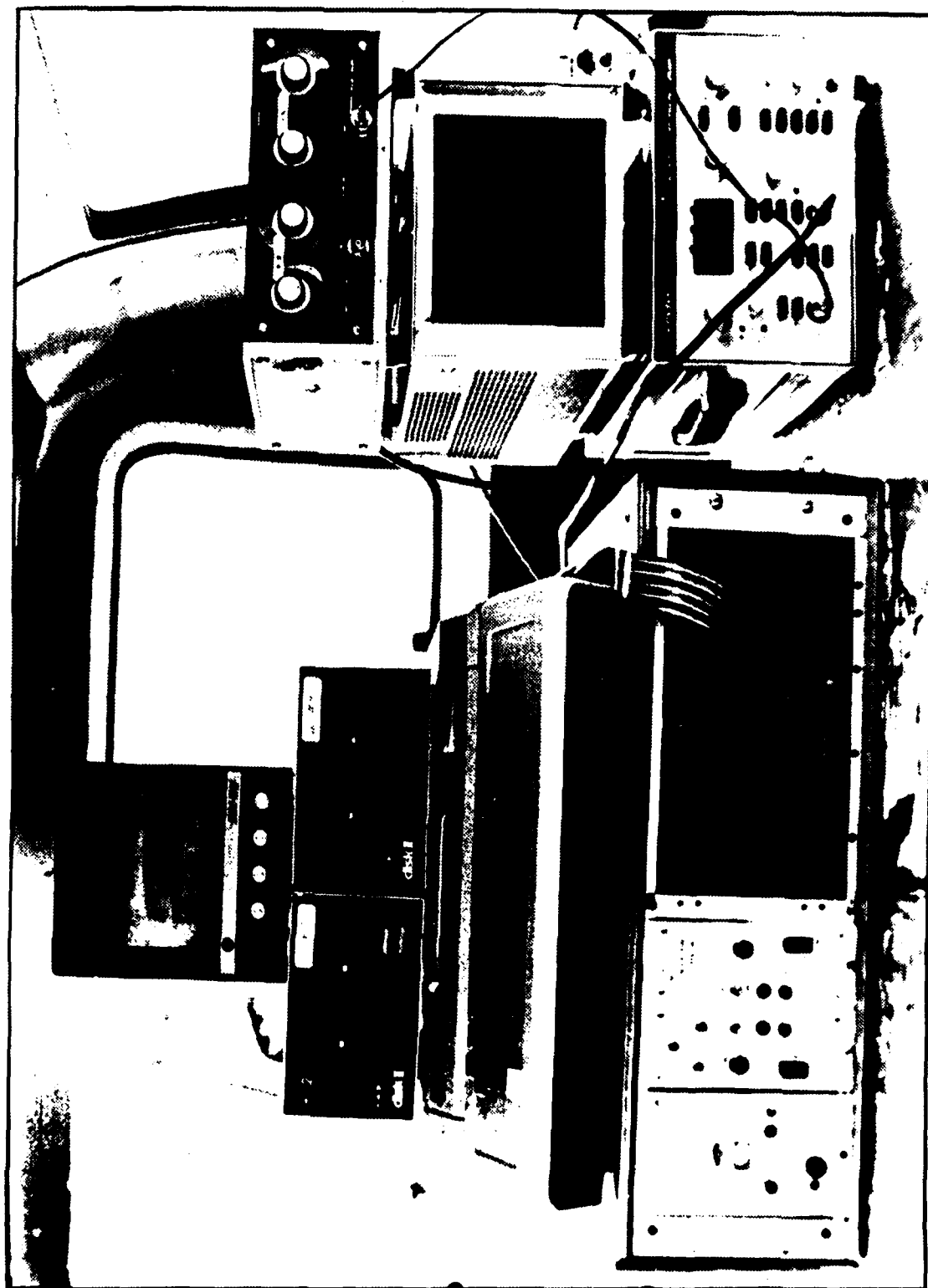

Figure 9. *Prototype SX-7*

1. Repeat the data-taking process using new filter and gain parameters if desired. The new data are written over the old data on the file to avoid duplication and erroneous data.
2. Terminate the logging set.
3. Call for a display of the record from the last data-taking position and then go to Option 1 or 2.

### **Data Printer**

A versatile graphic printer-plotter is interfaced to the central computer. The sonar signal displayed on the video monitor is immediately printed on the printer for a permanent record. The data records from up to 1,000 data positions can be sequentially printed to provide an easily interpretable section.

The printer can also be used for other purposes. Data which has been recorded on the disks during a logging process can be recalled from the disk at a later date and printed in the same format as the field data were printed, or in one of several other formats. Programs can be entered into the computer to change the print mode, and also to change the vertical or horizontal scale, and to combine signals. *Figure 10A* shows a data run from Colorado. The receiver is moved down the hole while the transmitter is stationary. The irregularities are caused by fractured rock. Another program computes the signal energy envelope, and prints the positive half of the envelope. This demodulated signal is sometimes more easy to work with during interpretation.

The printer is also useful in the print mode to list data file numbers, and to print the output of analytical programs. One such program (*DATAANAL*) allows the operator to display records on the video screen and to pick the P-wave and S-wave arrivals with a video cursor. The data are automatically entered into the computer and analyzed to derive:

1. P-wave and S-wave arrival times
2.  $V_p$  and  $V_s$
3.  $V_p/V_s$  ratios
4. Poisson's ratio

*DATAANAL* compensates for measured borehole deviation, and also for slope distance if the transmitter and receiver are not at the same elevation. *Figure 10B* shows this capability. This program was used to plot  $V_p$  and  $V_s$  for the MERADCOM contract requirements.

The printer-plotter can be used for other work when the borehole sonar is not being used in the field. Because the central computer is a general purpose computer which can be used for other purposes when not being used for geologic logging, the printer can be used with it to produce reports, documents, and technical data.

### **X-Y Plotter**

Although not physically part of the borehole sonar system, the data plotter is an important peripheral and can be any analog X-Y plotter. The records and files attached were plotted on an Esterline-Angus XY575 plotter.

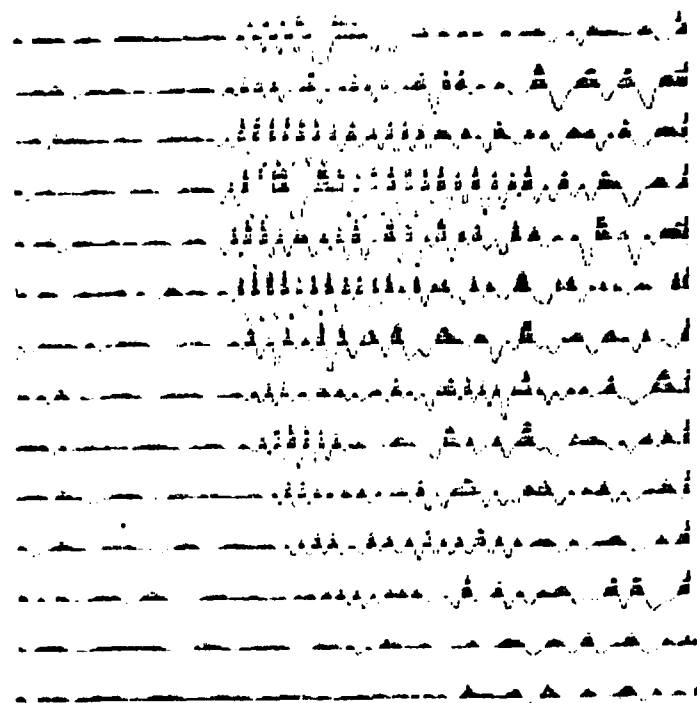

DEPTH		ARRIVAL		VELOCITY		POISSON'S	
XMIT	RCV	P-WAVE	S-WAVE	P-WAVE	S-WAVE	VP/VS	RATIO
142	142	2.78	5.53	11776	5921	1.98	.33
142	145	2.62	5.57	12538	5912	2.12	.356
142	148	2.65	5.47	12542	6089	2.05	.345
142	151	2.62	5.41	12947	6284	2.06	.345
142	154	2.69	5.53	12982	6305	2.05	.345
142	157	2.78	5.41	12949	6664	1.94	.319
142	160	2.91	5.5	12849	6793	1.89	.305
142	163	2.97	5.53	13090	7031	1.86	.297
142	166	3.07	5.88	13238	6903	1.91	.313
142	169	3.25	6.29	13031	6745	1.93	.317
142	172	3.38	6.55	13125	6784	1.93	.317
142	175	3.6	6.83	12895	6805	1.89	.306
142	178	4.11	7.37	11836	6604	1.79	.273
142	181	4.84	8.07	10523	6314	1.66	.218

Figure 10. **Graphics Plotter Output.**

- A) A data printout from crosshole work in Colorado is shown. Notice that as the receiver is moved down the hole the distance increases and the arrival time increases.
- B) The results of the arrival-time analysis program (DATAANAL) are tabulated. Both A and B were printed on the printer-plotter using software developed by SONEX.

In use, the data files are read from the diskettes by the control computer. Each file represents a sonic signal train. The file is displayed on a video monitor just as it was seen in the field. Unless the operator rejects the data, they are played out to the analog plotter and the computer goes back to the diskette for the next sequential file. The operator can set the X and Y scales of the plotted data.

In *Figure 11*, a single data signal is shown in three forms. *Figure 11A* is a photograph of the signal as it would be seen in the field or on the video monitor during the plotting process. A time scale, marked in milliseconds, appears at the bottom of the photograph.

*Figure 11B* shows what the signal would look like if plotted on the data plotter using the same vertical and horizontal (Y and X) scale. The plotted data appear smoother because the plotter can plot each of the 1,768 data samples individually. The video monitor has only 280 pixels, so roughly every sixth data sample can be shown.

*Figure 11C* shows the same data, but it has been reduced in vertical scale and is slightly elongated in the horizontal. This scale was used for most of the data file sets included in the report. Using the reduced vertical scale, most of the individual crosshole surveys can be presented in their entirety on a single page. The basic recorded data are not affected by the plotting. If it is appropriate to select a different plotting scale or method to compare the pre-tunnel and post-tunnel data, this can be done easily.

The record shown in *Figure 11* is data taken at Idaho Springs, Colorado. The transmit and receive probes are 190 feet deep in boreholes No. 6 and No. 7, respectively. The first sonic arrival (P-wave arrival) occurred at about 2.9 milliseconds; a second arrival (possibly the S-wave) occurred at about 4.9 milliseconds. Holes No. 6 and No. 7 are about 33 feet (10 meters) apart; therefore, the apparent P-wave velocity is about 11,400 fps and the apparent S-wave velocity is about 6,700 fps.

### **Control Module**

The control module interacts with the computer to provide operator interface. It can be used without the control computer to manually run the winches that raise and lower the probes and to fire the sparker. However, without the computer there is no probe depth information and the signal data cannot be recorded for storage although they can still be displayed on the CRT storage monitor and observed by the operator.

### **Winches**

Two interchangeable winches are included in the system. Each has a three-quarter horsepower variable speed, reversible motor; the nominal capacity for 1,000 feet of 3/16-inch, four-conductor armored logging cable; and weighs approximately 150 pounds. The winches are designed with independent frameworks so that they can be lifted and moved easily by two men. A 20-foot control cable connects each winch to the control module.

The logging cable is equipped with a Gearhardt-Owens type cable head (thus, it can support any other type of downhole probe with a Gearhardt-Owens probe head). Probe power and signal communications are taken off the winch reel through a six-channel gold-contact slip-ring unit.

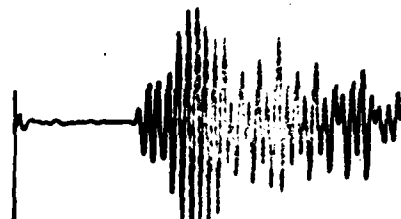
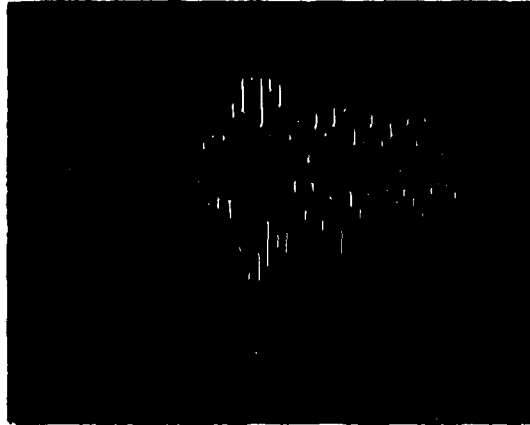

MILLISECONDS



MILLISECONDS

Figure 11. A typical cross-hole data record from Idaho Springs, Colorado. The two holes surveyed were nominally 10 meters apart. Time-zero, the initiation of the sonic pulse, is at the left of the record. Elapsed time between initiation in Hole 7 and reception in Hole 6 is shown in milliseconds at the bottom of each trace.

- A) A photograph of the record displayed in the field on a video monitor
- B) The same data drawn to the same scale on an X-Y plotter.
- C) The same data with the scale changed to permit more traces to be plotted on one sheet for comparison

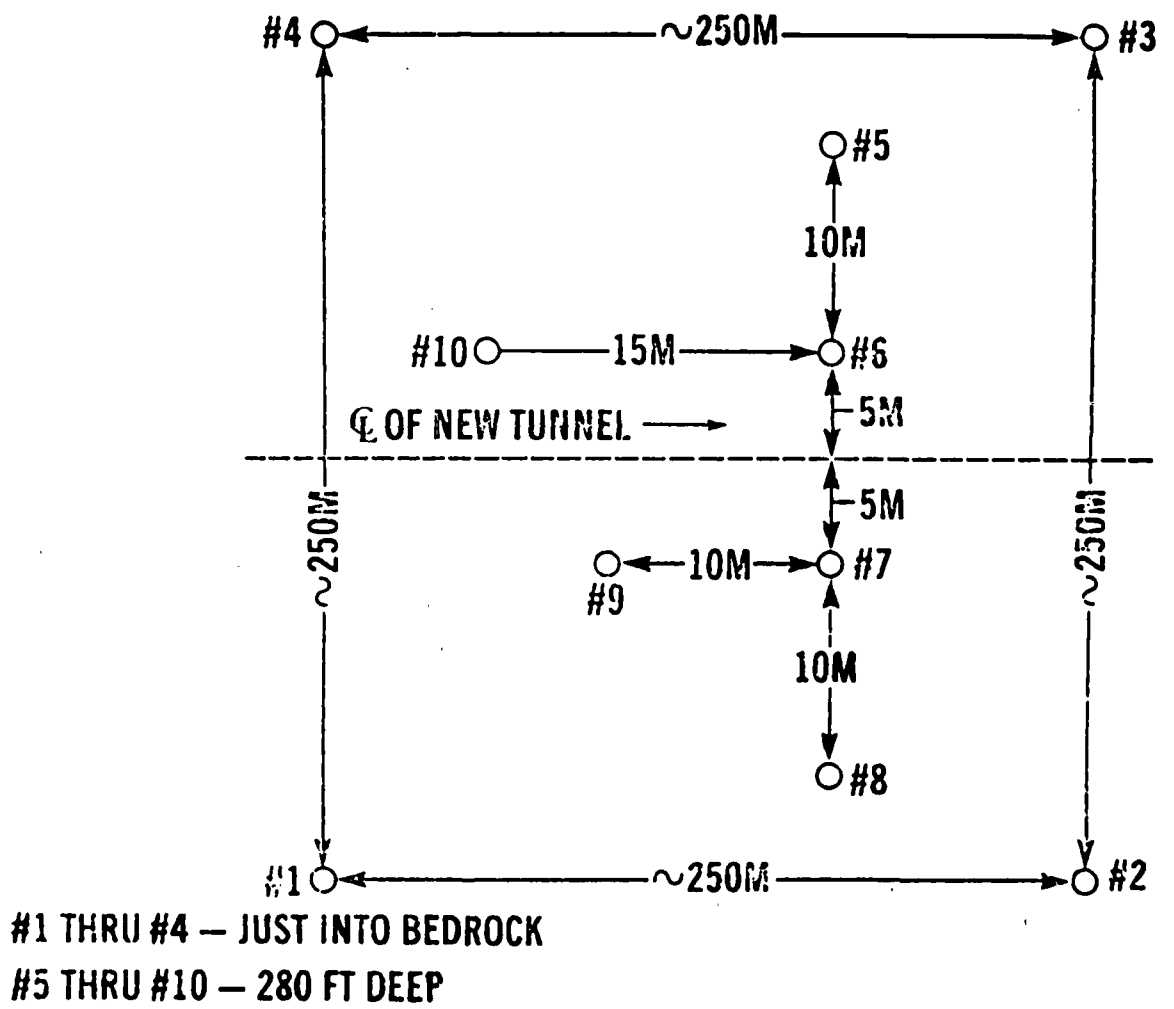

Figure 12. Idaho Springs Test Site Borehole Layout.

## IDAHO SPRINGS, COLORADO

### Site Description

The Idaho Springs field program was conducted at the Colorado School of Mines Experimental Test Mine in Idaho Springs, Colorado. The mine was started as a lead-silver-gold prospect in fractured and veined granitic rocks; and it is now used by the Colorado School of Mines as a teaching site and for mining research and experimentation.

At the site a clearing has been leveled on a spur of rock overlooking the town of Idaho Springs. The cleared area is about 8,400 feet above sea level. Six boreholes have been drilled to depths of about 280 feet. *Figure 13* shows the borehole layout and numbering scheme.

The borehole collar elevations were surveyed by SONEX and C.S.M. personnel. Elevations were taken on top of the PVC casing protruding from each hole. All elevations were calculated relative to the casing-top in hole No. 7. *Table 1* shows the relative elevations. The absolute elevation is not known.

Table 1

### BOREHOLE COLLAR ELEVATIONS

Datum Point - Hole No. 7 Collar

Hole Number	Relative Elevation
5	-8.4'
6	0.0'
7	0.0'
8	-0.8'
9	-0.2'
10	+0.2'

Depths for the SONEX borehole sonar data are referenced to this datum point. The transmit and receive probes measure 8.5 feet and 4.0 feet respectively from the cable connector to the active element at the bottom. Thus when the transmit-probe cable connector was at casing-top level in Hole 7, the probe depth was recorded as 8.5 feet, the location of the active transmit element.

The nature of the rock can be observed in the tunnel that was started at the base of the hill and penetrates to the borehole area. The rock is severely fractured; there are major fractures, faults, and gouge zones present. Because of the drainage provided by the fracturing and the exposed position of the rock spur, the rock is dry. Attempts to fill the boreholes with water have not been successful. Fortunately, it has been possible to keep water in some holes by continuous pumping or continuously recharging from a water truck. (As will be discussed later, water is essential as an energy-coupling medium.)

The tunnel at the base of the rock spur was designed to pass between the boreholes as shown in *Figure 13*. It is about 8 feet by 8 feet, and its roof is 157 feet below ground level at the boreholes. The objective of the field test was to define the geophysical response before the tunnel was completed and after the tunnel had penetrated between the boreholes. This should provide confidence that the geophysical tunnel anomalies seen at tunnel sites are, in fact, valid.

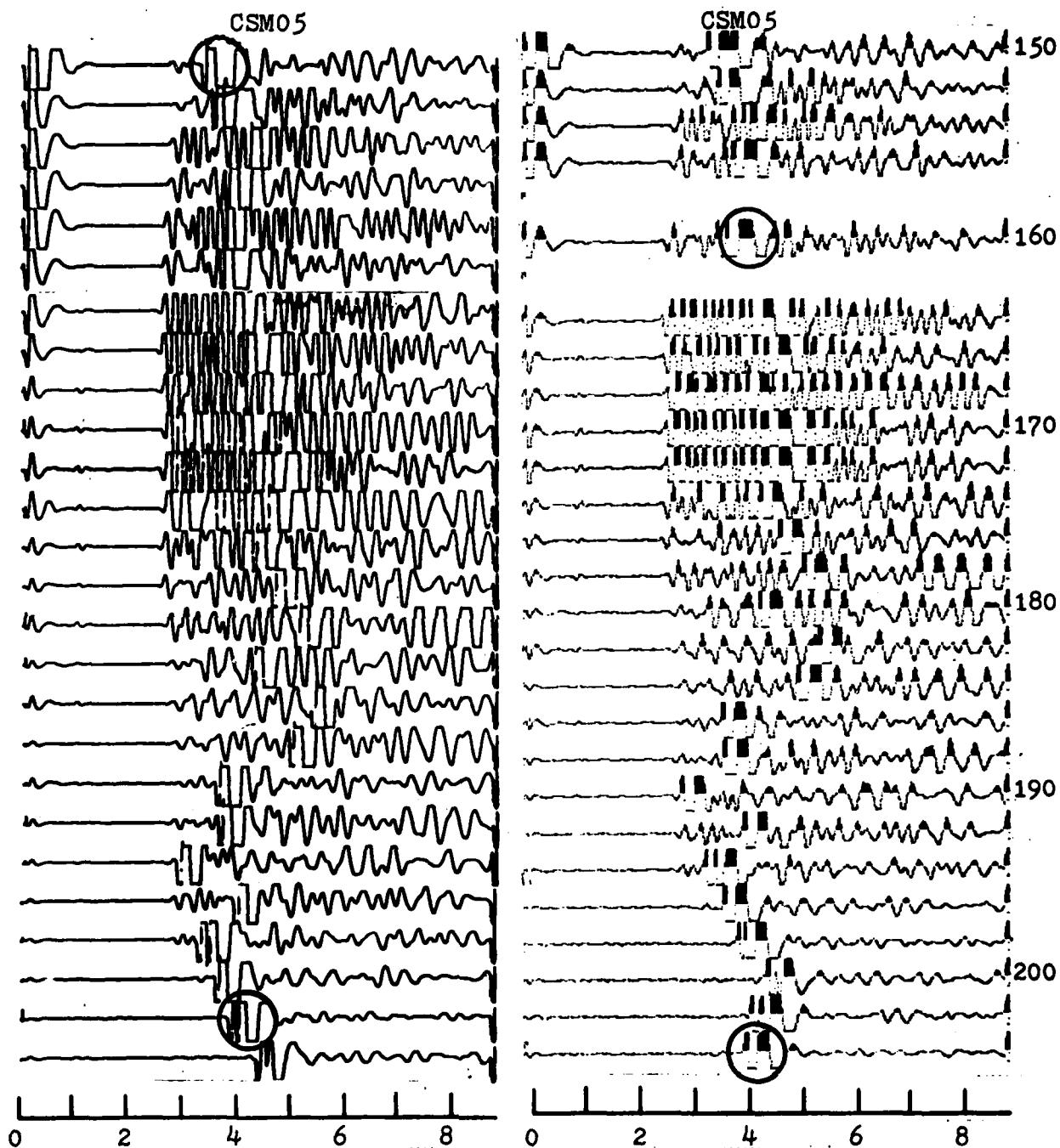

Figure 13. **Crosshole Survey Between Holes 6 and 7**, which are spaced 33 feet apart. Apparent P-wave velocities range from 12,700 fps at 166 feet to 8,250 fps at 200 feet deep. No corrections for hole drift have been included. Data file is CSM05. Circled spikes are caused by interference from the winch motor circuitry. Each trace has one such spike, usually between 4 and 5 milliseconds. Corrections were made so that these do not occur on later surveys. 14A was plotted on the analog X-Y plotter. 14B was plotted on the graphics printer and the scale photographically reduced.

### **Field Activities — 1980**

Field work at Idaho Springs was conducted during two 1-week periods: July 21-25, 1980, and October 13-17, 1980. During the first week it was discovered that the six boreholes that were to be used for the borehole sonar surveys were not water-filled and that the fractured rock was so porous that the holes would not hold water when filled. Many hours were lost while CSM tried to seal the holes by manually adding bentonite to the hole fluid. It became apparent that the most feasible approach would be to arrange a pumping system and a tank at the hole site so that water could be continuously added during the logging process. Since the pumping system and lines could not be immediately set up, it was necessary to leave the site and return at a later date to perform the desired measurements.

Enough work was done in the first week to verify that good crosshole sonar data could be acquired between Holes 6 and 7, which straddle the line of the tunnel advance. Some external noise interference was experienced, but it was not serious enough to affect the data adversely. In October the field crew returned to Idaho Springs to complete the pre-tunnel data acquisition. Five additional days were spent on site. As before, the survey process was disrupted by the lack of water. The pumping system capacity was insufficient to keep some of the holes full of water.

Fortunately, the critical holes — in the center of the pattern and straddling the tunnel centerline — held water well enough. The water level in these holes could be maintained during logging if water was added from the piping system and truck reservoir atop the hill. A full matrix of crosshole data was acquired in these holes from 142 feet down to 181 feet.

Table 2 lists the crosshole files acquired in 180 prior to the completion of the tunnel. The columns show the following data:

DATE:	The date on which the survey was done
FILE NUMBER:	A five-character header which identifies a group of data files. The file name for each file is used to call up individual data records. (File name includes the FILE NUMBER and the T and R depths, i.e., CSM34- 190-190)
HOLE- X'MIT	The number of the hole in which the SX-7 transmitter probe was placed
REC	The number of the hole in which the SX-7 receiver was placed.
T/R POSITION	Transmitter/Receiver (T/R) location data in feet for starting position, ending position and the interval between sample points.
FROM	The probe depth for T and R at the start of a data run.
TO	The probe depth for T and R at the end of a data run.
SPACE	The depth interval between consecutive sample points.
FILTER	The setting of the active filter band pass, given in kilohertz.
TIME	Time in milliseconds for a full data record.

To give an example, data file CSM05 started with the transmitter at 172 feet in Hole 7 and the receiver also at 172 feet in Hole 6 (172-172). The survey ended with the transmitter and the receiver each 254 feet deep in the holes (254-254). In this survey, both the transmitter and receiver were moved two feet between each sample point (2-2).

**TABLE 2**  
**IDAHO SPRINGS TEST SITE — DATA FILES**  
**1980 — PRE-TUNNEL**

DATE	FILE #	HOLE # X'MIT	REC	— TIR POSITION —			FILTER (kHz)	TIME (MS)	REMARKS
				FROM	TO	SPACE			
July 23	CSM05	7	6	172-172	254-254	2-2	1-8	10	Has motor noise spikes
July 25	CSM14	7	6	142-142	166-142	3-0	1-8	10	Lost water in hole
July 25	CSM15	7	6	142-178	178-178	3-0	1-8	10	
July 25	CSM16	7	6	142-145	178-145	3-0	1-8	10	
July 25	CSM17	7	6	142-148	178-148	3-0	1-8	10	Fan Patterns
July 25	CSM18	7	6	142-151	178-151	3-0	1-8	10	
July 25	CSM19	7	6	142-154	178-154	3-0	1-8	10	
July 25	CSM20	7	6	142-157	—	3-0	1-8	10	Lost water-file not used
Oct. 14	CSM30	7	6	142-142	142-181	0-3	2.5-8	10	
Oct. 15	CSM31	7	6	145-142	145-181	0-3	2.5-8	10	
Oct. 15	CSM32	7	6	148-181	148-181	0-3	2.5-8	10	
Oct. 15	CSM33	7	6	151-142	151-181	0-3	2.5-8	10	
Oct. 15	CSM34	7	6	151-142	154-181	0-3	2.5-8	10	
Oct. 15	CSM35	7	6	157-142	157-181	0-3	2.5-8	10	
Oct. 15	CSM36	7	6	160-142	160-181	0-3	2.5-8	10	
Oct. 15	CSM37	7	6	163-142	163-181	0-3	2.5-8	10	Relogged Fan Patterns
Oct. 15	CSM38	7	6	166-142	166-181	0-3	2.5-8	10	
Oct. 15	CSM39	7	6	169-142	169-181	0-3	2.5-8	10	
Oct. 15	CSM40	7	6	172-142	172-181	0-3	2.5-8	10	
Oct. 15	CSM41	7	6	175-142	175-181	0-3	2.5-8	10	
Oct. 15	CSM42	7	6	178-142	178-181	0-3	2.5-8	10	
Oct. 15	CSM43	7	6	181-142	181-181	0-3	2.5-8	10	
Oct. 16	CSM45	8	7	100-100	140-140	10-10	5-6.3	10	
				140-180	180-180	2-2	5-6.3	10	
				180-180	220-220	5-5	5-6.3	10	
Oct. 16	CSM46	8	7	200-200	140-140	5-5	5-6.3	10	
Oct. 16	CSM50	8	6	195-195	150-150	5-5	5-6.3	20	
Oct. 16	CSM52	5	8	180-180		5-5	5-6.3	10	With aluminum screen for noise filter
Oct. 16	CSM53	5	6	180-180		5-5	5-6.3	10	Without aluminum screen
Oct. 16	CSM54	7	9	180-180	120-120	5-5	5-6.3	10	
Oct. 17	CSM55	7	5	180-180			5-6.3	20	Lost water in hole 5, not completed

Data file CSM14 started with the transmitter and receiver at a depth of 142 feet (142-142). At the end of the survey the transmitter was at 166 feet, but the receiver was still at 142 (166-142). The transmitter was raised 3 feet between each measurement, and the receiver remained stationary (3-0). The same notation system was used for tables showing the post-tunnel data and for the data taken at Manatee Springs.

These data provided a good coverage of the pre-tunnel condition of the rock. The next step was to resurvey the holes in 1981 after the tunnel had been excavated past the area of the boreholes.

#### **Field Activities — 1981**

The 1981 field work was conducted over a three-week period from November 4 to Friday November 20, 1981. The crew worked seven days a week to take advantage of the unusually good fall weather in the Colorado Rockies.

During the interval between the 1980 tests and November 1981 an attempt was made by CSM to seal the holes so that they would hold water. One of the six holes, which would not hold water at all in 1980 (No. 5) was improved significantly. The others were no better than in 1980. One hole (No. 10) could not be used at all. The pipe recharge system used in 1980 had been removed so as not to interfere with the surface resistivity tests. We were able to complete the surveys by constantly recharging the holes with water from a water truck, which in turn was filled from a City of Idaho Springs hydrant some 800 feet below the test site. Each truck load required one hour round trip. On some days, four loads were needed.

Data files CSM60 through CS128 were recorded. *Table 4* lists the surveys conducted. On the first day, we verified that the tunnel between Holes 6 and 7 could be detected (CSM61) at a depth of 158 to 166 feet below the collar of Hole 7. A fan pattern was surveyed using Holes 6 and 7 and duplicating the patterns run in 1980, contained in files CSM30 through CSM43. These data, in files CSM71 through CSM84 confirm the ability to define the locus of the tunnel and to describe its cross-sectional size in the plane of the two boreholes.

A second matrix was acquired using the same holes, but exchanging the transmitter-receiver positions to verify that the data were the same. These data are in files CSM85 through CSM99.

A crosshole matrix was acquired using Holes 7 and 5, separated by 20 meters, to demonstrate that the tunnel could be detected in the twenty-meter separation, and that it could be identified and located. These data are in files CSM113 through 118.

Crosshole data were recorded between six pairs of holes so that  $V_p$  and  $V_s$  values could be measured. Sample points were set one-half foot apart in depth. The file numbers and the respective pairs of holes for each file are shown in *Table 3*.

**TABLE 3**  
 **$V_p$   $V_s$  DATA FILES**

<b>File Number</b>	<b>Transmit</b>	<b>Receive</b>	<b>Hole-to-Hole Spacing</b>
CSM64 & 65	7	6	10 meters
CSM66 & 67	6	7	10 meters
CS100	7	8	10 meters
CS102	9	8	14 meters
CS103	6	9	14 meters
CS106	7	9	10 meters
CS107	6	5	10 meters

**TABLE 4**  
**IDAHO SPRINGS TEST SITE — DATA FILES**  
**1981 — POST-TUNNEL**

DATE	FILE #	HOLE # X'MIT	REC	— T/R POSITION —			FILTER (kHz)	TIME (MS)	REMARKS
				FROM	TO	SPACE			
Nov. 4	CSM60	7	6	169-169	230-230	1-1	2.5-8	10	Lost water in hole at 182'
Nov. 4	CSM61	7	6	113-113	190-190	1-1	2.5-8	10	
Nov. 4	CSM62	7	6	150-190	150-190	1-1	2.5-8	10	Lost water at 152'
Nov. 4	CSM63	7	6	150-195	150-195	1-1	2.5-8	10	Lost water-did not complete
Nov. 5	CSM64	7	6	210-210	270-270	.5-.5	2.5-6.3	10	Change filter to 5.0-6.3 at 240'
Nov. 5	CSM65	7	6	270-270	212-212	.5-.5	5-6.3	20	
Nov. 6	CSM66	6	7	210-250	156-156	.5-.5	5-6.3	20	Lost water at 165'
Nov. 7	CSM67	6	7	170-170	170-122	.5-.5	5-6.3	20	Combine with CSM66 to make CSM67-new
Nov. 7	CSM68	6	7	127-127	99-99	.5-.5	5-6.3	20	Run to verify CSM67 data
Nov. 7	CSM71	6	7	142-142	184-142	3-0	5-6.3	10	CSM71 through CSM84
Nov. 7	CSM72	6	7	133-145	184-145	3-0	5-6.3	10	comprise one fan pat-
Nov. 7	CSM73	6	7	142-148	187-148	3-0	5-6.3	10	tern locating the
Nov. 7	CSM74	6	7	139-151	187-151	3-0	5-6.3	10	tunnel anomaly
Nov. 7	CSM75	6	7	139-154	199-154	3-0	5-6.3	10	
Nov. 7	CSM76	6	7	142-157	199-157	3-0	5-6.3	10	
Nov. 11	CSM77	6	7	142-160	181-160	3-0	5-6.3	10	
Nov. 11	CSM78	6	7	139-163	181-163	3-0	5-6.3	10	
Nov. 11	CSM79	6	7	142-166	181-166	3-0	5-6.3	10	
Nov. 11	CSM80	6	7	142-169	181-169	3-0	5-6.3	10	
Nov. 11	CSM81	6	7	142-172	181-172	3-0	5-6.3	10	
Nov. 11	CSM82	6	7	142-175	181-175	3-0	5-6.3	10	
Nov. 11	CSM83	6	7	142-178	181-178	3-0	5-6.3	10	
Nov. 11	CSM84	6	7	142-181	181-181	3-0	5-6.3	10	
Nov. 11	CSM85	7	6	142-142	142-184	0-3	5-6.3	20	CSM85 through CSM99
Nov. 11	CSM87	7	6	145-142	145-181	0-3	5-6.3	20	comprise a reversed
Nov. 11	CSM88	7	6	148-142	148-184	0-3	5-6.3	20	fan pattern locating
Nov. 11	CSM89	7	6	151-142	151-181	0-3	5-6.3	20	the tunnel anomaly.
Nov. 11	CSM90	7	6	154-130	154-181	0-3	5-6.3	20	
Nov. 11	CSM91	7	6	157-142	157-181	0-3	5-6.3	20	
Nov. 11	CSM92	7	6	160-142	160-181	0-3	5-6.3	20	
Nov. 11	CSM93	7	6	163-142	163-181	0-3	5-6.3	20	
Nov. 11	CSM94	7	6	166-142	16-181	0-3	5-6.3	20	
Nov. 11	CSM95	7	6	169-142	169-181	0-3	5-6.3	20	

**TABLE 4 (continued)**  
**IDAHO SPRINGS TEST SITE — DATA FILES**  
**1981 — POST-TUNNEL**

DATE	FILE #	HOLE # X'MIT	REC	— T/R POSITION —			FILTER (kHz)	TIME (MS)	REMARKS
				FROM	TO	SPACE			
Nov. 11	CSM96	7	6	172-142	172-181	0-3	5-6.3	20	
Nov. 11	CSM97	7	6	175-142	175-181	0-3	5-6.3	20	
Nov. 11	CSM98	7	6	178-142	178-184	0-3	5-6.3	20	CSM98 and 99 have high noise caused by improper probe sparking. Data are valid for arrival times
Nov. 11	CSM99	7	6	181-139	181-181	0-3	5-6.3	20	
Nov. 12	CS100	7	8	270-270	59-59	.5-.5	5-6.3	10	
Nov. 13	CS101	9	8	270-270	260-260	.5-.5	5-6.3	10	
Nov. 13	CS102	9	8	270-270	112-112	.5-.5	3.15-4	10	File completed on Nov. 16, lost water
Nov. 13	CS103	6	9	270-270	81-81	.5-.5	3.15-4	10	
Nov. 14	CS104	7	9	130-130	191-191	1-1	5-6.3	20	Increase gain
Nov. 14	CS105	7	9	153-153	130-130	1-1	5-6.3	20	
Nov. 14	CS106	7	9	270-270	60-60	.5-.5	5-6.3	10	
Nov. 16	CS107	6	5	270-270	88-88	.5-.5	5-6.3	10	Changed time scale at 176'
Nov. 16	CS108	7	5	190-190	130-130	1-1	5-6.3	10/20	
Nov. 17	CS109	7	9	185-185	190-190	1-1	1.6-3.15	10	CS109 to CS119 use new spark chamber—better output.
Nov. 17	CS110	7	9	190-190	135-135	1-1	1.6-3.15	10	
Nov. 17	CS111	7	9	190-190	130-130	1-1	1.6-3.15	20	Depth may be 8' off for receiver
Nov. 17	CS112	7	9	132-132	190-190	1-1	1.6-3.15	40	
Nov. 17	CS113	7	5	130-130	188-188	1-1	1.6-4	20	
Nov. 17	CS114	7	5	188-196	130-138	1-1	1.6-4	40	
Nov. 17	CS115	7	5	130-170	190-170	1-0	1.6-4	20	
Nov. 17	CS116	7	5	162-129	162-198	0-1	1.6-4	20	
Nov. 17	CS117	7	5	130-162	190-162	1-0	1.6-4	20	
Nov. 17	CS119	8	5	135-135	185-185	1-1	1.0-2.5	40	
Nov. 19	CS120	7	PE	190	140	1	16-31	10	
Nov. 19	CS121	7	PE	190	130	1	16-31	10	Looking away from tunnel
Nov. 19	CS122	9	PE	140	189	1	16-31	10	Looking towards tunnel
Nov. 19	CS123	9	PE	139	189	1	16-31	10	Looking away from tunnel
Nov. 20	CS124	6	PE	140	190	1	16-31	10	Looking away from tunnel
Nov. 20	CS125	6	PE	190	129	1	16-31	10	Looking toward tunnel
Nov. 20	CS126	6	PE	180	130	1	16-31	10	Omnidirectional
Nov. 20	CS127	7	PE	180	140	1	16-31	10	Omnidirectional
Nov. 20	CS128	8	PE	180	149	1	16-31	10	Omnidirectional

CS120 through 128 use the SX-8 piezoelectric pulse echo probe

Data files CS109 through CS118 demonstrate the use of a new SX-7 spark probe with more energetic sonic output. The data are taken between Holes 7 and 9, a distance of 10 meters; and between Holes 7 and 5, a distance of 20 meters. The latter pair of holes are on opposite sides of the tunnel and show the ability to see the tunnel between widely spaced holes. CS119 was recorded between Holes 5 and 8, a distance of 30 meters.

Data files 120 through 128 used the SX-8 pulse echo sonar.

### **Representative Data**

The following figures contain representative data files from the borehole survey conducted at Idaho Springs. Data have been reproduced from the data recorded on magnetic diskettes. The control computer was programmed to read selected data files in a given survey, in sequential order, and to plot the data record on an analog X-Y plotter.

An alternative way of plotting is to use the graphics printer supported by the system computer. Each method has advantages. The analog device presents a smoother appearance, and is better suited for reproduction. The X and Y scale factors can be changed to allow different data presentations to enhance the overall picture. The digital device is much faster, can be readily used in the field, and in some cases makes the data easier to comprehend. Also with the graphics printer a series of data records can be reviewed while the data is being collected in the field. Additional surveys can be conducted to clear up ambiguous data and surveys can be expanded if the need is apparent.

Both types of data display are used in this report. *Figure 13* shows a comparison of the two plotting methods with approximately the same scale.

*Figure 13* is the first survey conducted between Holes 7 and 6 in July 1980. The bottom depth of the survey is 254 feet; the top depth is 136 feet. Only the portion from 150 to 204 feet is shown. The vertical spacing between data records is two feet. The plot combines data from CSM03 and CSM05 files.

This first survey shows a diversity of rock types evidenced by the variation in signal character, arrival times, and attenuation. The earliest arrival time (2.6 msec) is seen at the 166-foot depth; the latest (4.0 msec) is seen at the 200-foot depth. The apparent P-wave velocities determined by these arrival times are:

166-foot depth = 2.6 msec or  $\sim 12,700$  fps

200-foot depth = 4.0 msec or  $\sim 8,250$  fps

In calculating the velocity, it is assumed that the holes are 33 feet apart throughout their length — as they are at the collar. We know this is not quite true, but at this time the absolute P-wave velocity is not important and no hole-deviation corrections have been made.

This survey also indicates that all the investigated rock is low-density, fractured and faulted, and in other ways below normal as a conductor of sonic energy. The best rock appears to be near the depth of the tunnel, 160-170 feet.

The left hand side of the section equals time-zero, the time of the signal transmission. The first signals at the left hand side of each trace are an electromagnetic phenomenon associated with the spark discharge. These do not represent sonic data. The first-arrival sonic data in this file occurs about 3 milliseconds after time-zero.

**TABLE 5**  
**BOREHOLE DEVIATION**  
 DEVIATION DATA PROVIDED BY MERADCOM

HOLE NO.	BEARING	DISTANCE
5	216°	2.3 m
6	219°	2.3 m
7	165°	0.6 m
8	239°	1.7 m
9	210°	1.5 m
10	213°	2.4 m

**BOREHOLE SEPARATION**

HOLE PAIR	AT SURFACE	AT 270 FEET
5-6	32.8	33.1
6-7	32.8	38.0
7-8	32.8	30.8
8-9	45.9	48.5
7-9	32.8	30.2
6-9	45.9	49.2

In each trace a large spike can be seen, generally at 4 to 5 milliseconds. This is an artifact caused by the winch motor circuitry. In later surveys this was recognized, and the control programs modified to turn off the winch motor circuitry during the data reception time.

Additional surveys were conducted in other pairs of boreholes. *Figure 14A* illustrates the common-depth type of crosshole surveys. File CSM05, reproduced in *Figure 13*, was run in common-depth mode. As the survey was conducted, the transmitter and receiver were kept at equal depths in Holes 7 and 6. The same pattern was used for files BEFOR and AFTER shown in *Figure 15*.

*Figure 15* shows a comparison of crosshole data taken after the tunnel was driven with the baseline data. The tunnel anomaly is clearly seen.

*Figure 15A* is a composite file using the horizontal path as illustrated in *Figure 14A* (equal depths for transmitter and receiver). Data was extracted from files CSM30 through CSM43. This information represents the 1980 baseline survey. In this section the transmitter is in Hole 7 and the receiver is in Hole 6. Some variations in signal arrival time, signal amplitude, and signal frequency are noted. These are normal variations caused by the change in the nature of the rock.

*Figure 15B* is a composite file found in the same manner from files CSM71 through CSM84. This information represents the 1981, post-tunnel data. The transmitter is in Hole 6, the receiver in Hole 7. The effect of the presence of the air-filled tunnel is clearly seen. From 151 to 157 feet, and from 169 to 172 feet, the signal is delayed and reduced in amplitude but still detectable. Between 157 and 169 the crosshole signal almost disappears.

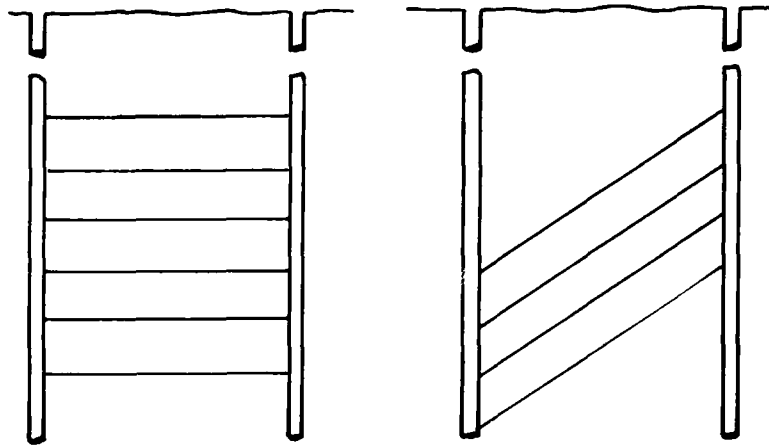

**Figure 14. Common-Depth and Vertical Offset Surveys.** In the common depth mode (A) the transmitter and receiver are moved together and kept at a common depth (elevation) in the hole. In the vertical-offset mode (B) the probes are offset and moved together, retaining the same offset. In different data runs different positive or negative offsets may be used.

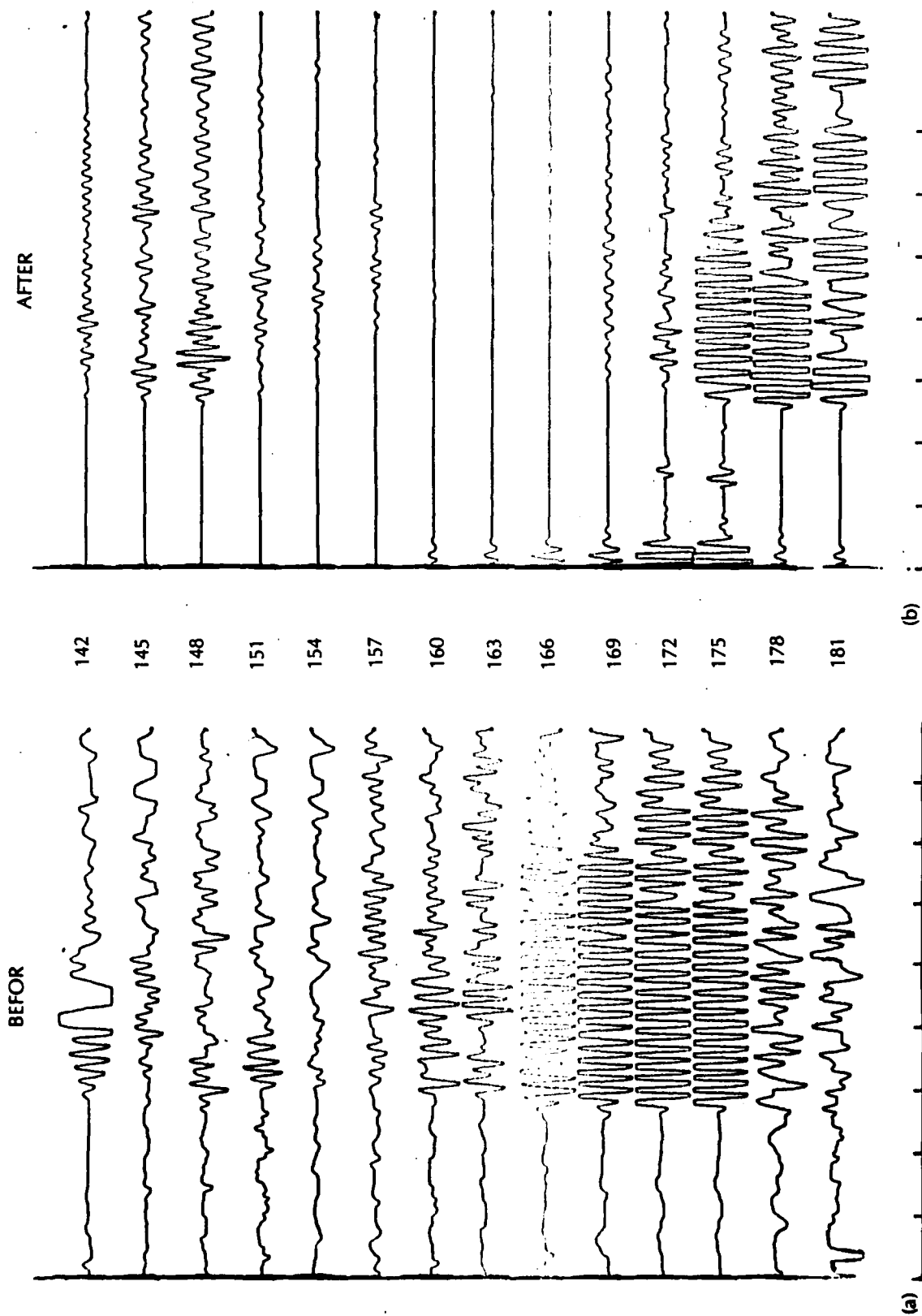

Figure 15. Comparison of Tunnel Anomaly with Normal Data. These two sectors were surveyed before and after the tunnel was driven. The same pair of holes was used, and the survey equipment was the same. The change in the signal strength and arrival time in 166 is attributable solely to the effect from the tunnel.

Figure 15B is diagrammatic of CSM30. The transmitter in Hole 7 was held stationary at 142 feet, and the receiver was lowered in 3-foot increments from 142 feet to 181 feet. The result is a file of 14 data records fanning across the area of interest. Figure 15C is diagrammatic of the combined files CSM30 to CSM43, which cover the area of interest where the tunnel is expected to appear. There are a total of 14 data files with 14 records per file or a total of 196 individual crosshole data records.

Figure 17 contains four of the data files that would make up the 14 files described. File CSM30 data was acquired with the transmitter at 142 feet in Hole 7 and the receiver lowered in 3-foot increments from 142 feet to 181 feet in Hole 6. For file CSM31, the transmitter was stationary at 145 feet and the receiver was lowered from 142 feet to 181 feet. For files CSM32 and CSM33 the transmitter was lowered to 148 feet and 151 feet, respectively, while in each case the receiver was traversed vertically through the 142-foot to 181-foot interval.

After the tunnel was completed, the same process of crosshole surveying was conducted using the same equipment and the same instrument settings. These data are shown in Figure 18. When the comparisons between these data are made, one can unequivocally see the response to the tunnel. Data files CSM85, 87, 88 and 89 are shown in Figure 18.

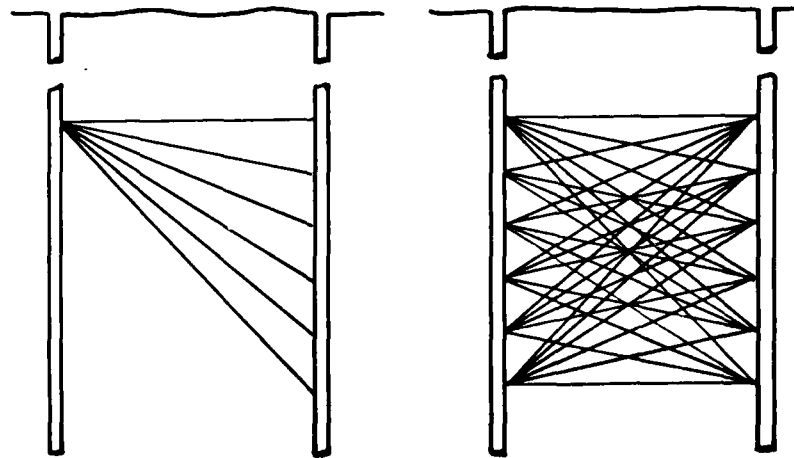

Figure 16. **Fan Patterns.** A single fan (A) is run with one probe held stationary and the other scanned past it in fixed depth increments. The fan may be repeated at many depths (B) to provide excellent coverage of an anomaly.

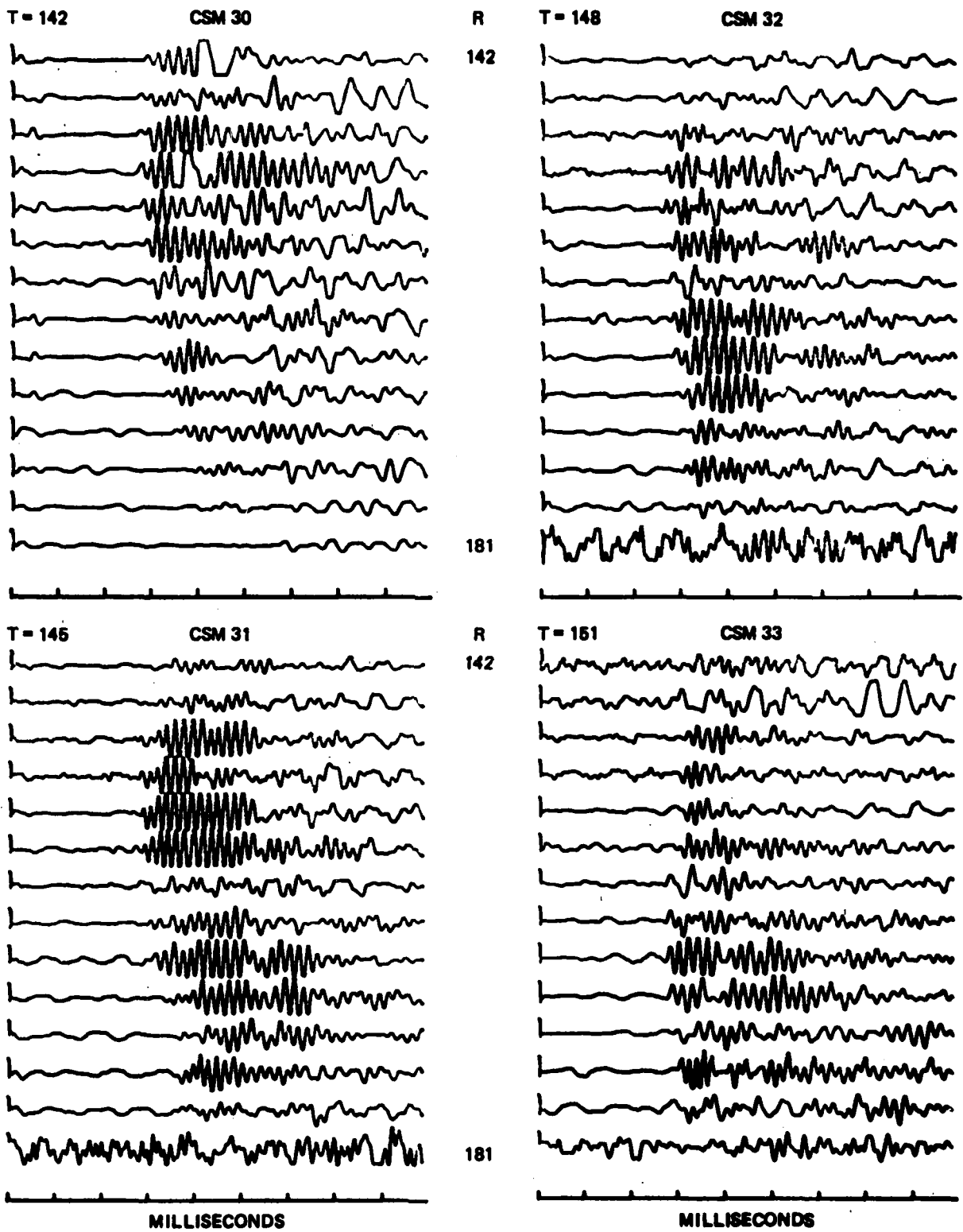

Figure 17. **Pre-Tunnel Fan Data.** Four fan crosshole surveys between Holes 6 and 7. Note the strong noise components in CSM31, 32 and 33 when the receiver is at 181 feet. Data files are CSM30, 31, 32, and 33. Data acquired in 1980.

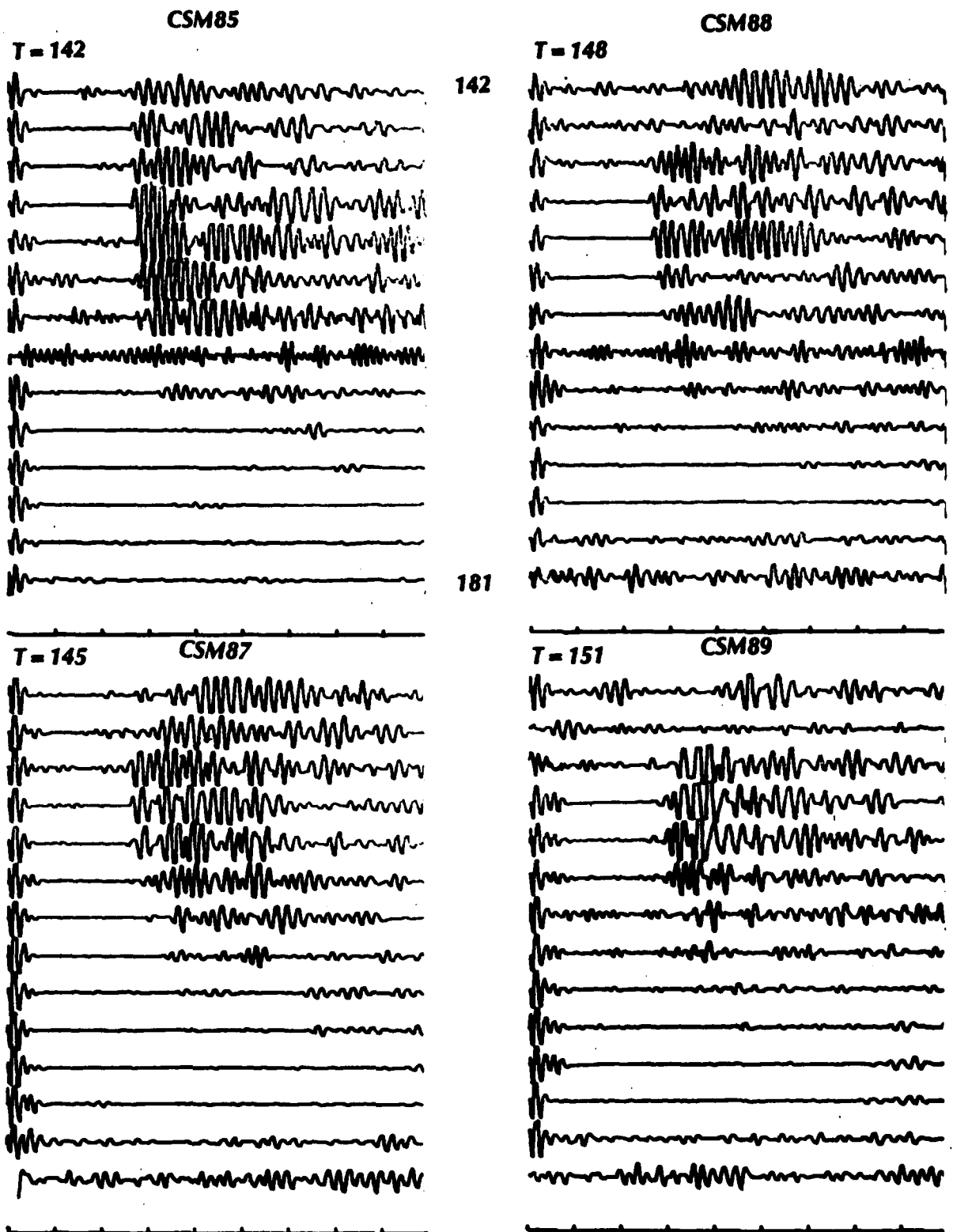

Figure 18. *Post-Tunnel Fan Data.* Four fan-pattern surveys between Holes 6 and 7. Data acquired in 1981. Sample stations are repeats of stations occupied in 1980 for the data shown in Figure 17. Data files are CSM85, 87, 88, and 89. Note the noise when the receiver is at 181 feet is still present.

### **Tunnel Detection**

A tunnel in rock can be detected using crosshole sonar, SX-7. Experimental data confirms that a velocity anomaly is detectable if the anomaly is large enough, and the difference in sonic velocity between the rock and the anomaly are great enough, in relation to the spacing between the transmitter and the receiver.

Figure 2 on page 6 illustrates the effect of an eight-foot air-filled tunnel on the same signal transmitted between two holes 66 feet (20 meters) apart. The sonic velocity of the rock is assumed to be 13,000 fps — about the same as is seen around the tunnel at Idaho Springs, but much lower than is usually seen in competent rock. The sonic velocity of air is about 1,100 fps. Under these parameters the signal delay caused by the presence of the tunnel is 6.6 milliseconds. The normal transmission time is 5.1 ms; the time with anomaly present is 11.7 ms, more than twice as long. Since the SX-7 can measure accurately and resolve time to 0.2 ms, the delay of a tunnel can be easily seen.

If in the case of Figure 2 the tunnel was filled with water instead of air the delay would be less, but would still be readily detectable.

58 feet of rock @	13,000 fps	= 4.46 ms
8 feet of water @	5,000 fps	= 1.60 ms
66 feet through rock and water		= 6.06 ms

The delay attributable to the water-filled tunnel would be 1.0 ms (6.1 ms – 5.1 ms), almost a 20% delay, still well within the range of detectability with the SX-7.

The calculations in Figure 2 and above do not take into consideration the relationship of the size of the anomaly to the transmitter-receiver spacing. Since even a so-called homogenous rock is to some extent a scatterer of sonic frequency waves, there will be some sonic energy which will be scattered and refracted around the anomaly to get to the receiver.

Empirical data indicates that this circumvention of the anomaly does not become an important factor with the SX-7 until the relationship between the transmitter-to-receiver spacing and the anomaly size approach 20 to 1. In the example discussed the ratio is 8.25 to 1 (66' to 8'). In general, when a crosshole survey is planned the maximum hole spacing should not exceed ten times the minimum target to be detected. There is a temptation to develop high-powered sources so that hole-to-hole spacing can be increased — but this may be counter-productive unless one is willing to reduce the degree of resolution obtainable.

Figure 19 shows two data files from the Idaho Springs test site. These are data extracted from several files of fan patterns and represent the common-depth signal from each fan pattern. The left hand section labeled BEFOR contains data acquired as a baseline survey in 1980. The tunnel which has been used as the central target was several tens of feet short of reaching the drillhole area. No effect of the tunnel can be seen. Signal arrival times vary from 2.6 ms to 3.0 ms, equivalent to  $V_p$  values of 12,615 fps and 10,933 fps respectively. The dashed line in Figure 19A denotes the position of the detectable signal first arrival time.

The right hand section labeled AFTER contains data acquired in 1981, after the 8 foot-by-8 foot tunnel had been driven beyond the area below the drill holes. The effect of the tunnel can be seen immediately. The dashed line is the "normal" location of the signal first arrivals transferred from the plot of the BEFOR Section. The solid line defines the signal arrivals for the AFTER section. The same data was seen in Figure 1.

File BEFOR

Transmit # 7	Receive # 6
Start 142	142
End 181	181
Incr. 3	3
Time 10 ms	

(Combined data records from CSM30 to CSM43)

\*\*\* Survey data from October 1980, before the tunnel was completed \*\*\*\*\*

File AFTER

Transmit # 6	Receive # 7
Start 142	142
End 181	181
Incr. 3	3
Time 10 ms	

(Combined data records from files CSM71 to CSM84)

\*\*\* Survey data from November 1981, after the tunnel was completed \*\*\*\*\*

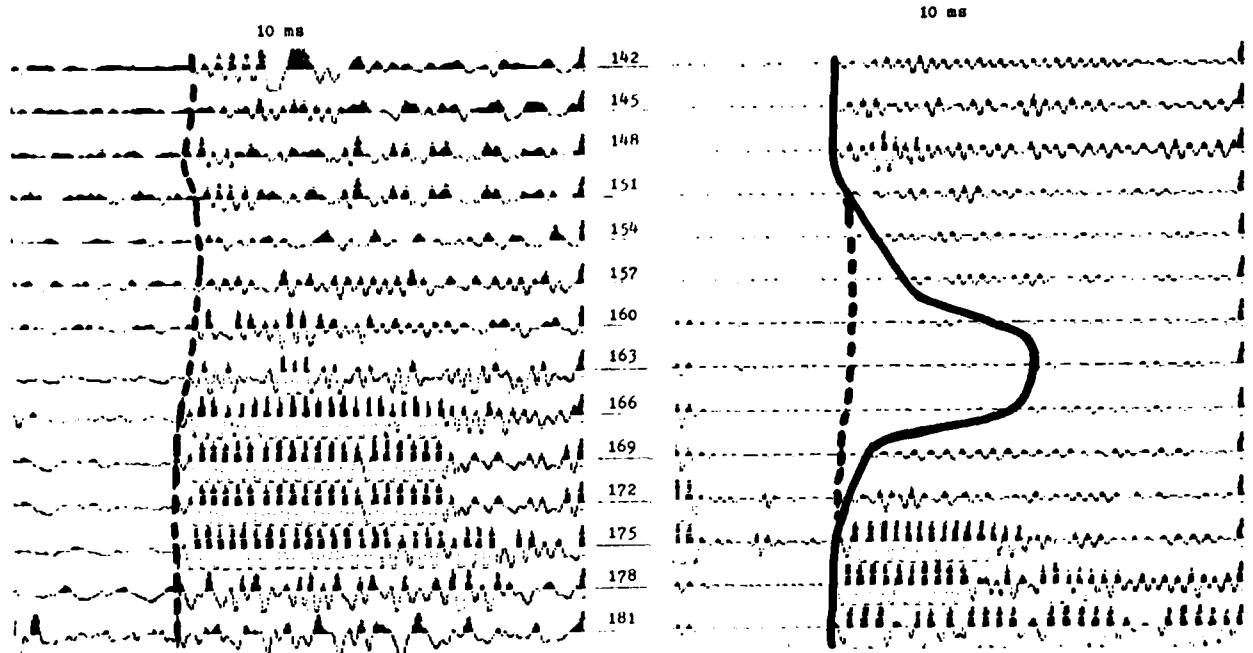

Figure 19. **Tunnel Detection by Crosshole Sonar.** These two files show the before and after comparisons of crosshole sonar data taken with the SONEX SX-7 borehole sonar. The dashed line in A is the normal signal arrival for the vertical section. The solid line in B shows the arrival times detected after the tunnel was completed.

Both sections were surveyed using the same pair of holes (6 and 7), the same depths for the sample points and the same equipment with the same gain and filter settings. The only important difference is the presence of the tunnel between the holes when the data for the AFTER section was taken.

The mean signal arrival time in the BEFOR file is approximately 2.7 milliseconds after the transmit pulse. Since the hole-to-hole separation is 10 meters, about 33 feet, the mean velocity ( $V_p$ ) is approximately 12,222 fps. This is also true for the AFTER file if only the top four and bottom three records are considered. The remaining seven records, representing some 12 feet or more of vertical section show some degree of delay of the crosshole signal. The greatest recognizable delay is at 163 where the crosshole signal arrival time is 5.5 milliseconds, more than twice the normal mean arrival time of 2.7 milliseconds. At 160 the signal is simply not discernable.

The observed  $V_p$  at 163 feet in the AFTER section is 5,500 fps. A velocity reading this low is absolutely incompatible with granitic rocks, no matter how broken or fractured they are. If an anomaly of this magnitude was detected in a tunnel reconnaissance program it would be unquestionable evidence of a tunnel, or other air-filled void.

Figure 20 is another section through Holes 6 and 7 detecting the tunnel. The data file number is CSM62. This corresponds to the AFTER section shown above except that data is shown for every foot vertically instead of every third foot, and the bandpass filter was set lower so that more of the signal is seen. The filter in the files shown in Figure 19 was set at 5-6.3 kHz pass. In Figure 20 the data was filtered to pass 2.5-8 kHz. The lower filter-pass setting enables us to see more of the signal transmitted through the tunnel and around the tunnel. The top three records of file CSM62 were taken when the water in the receiver hole (6) had dropped below the probe level. No crosshole data can be seen since the probe has lost coupling to the hole wall.

The previous two examples were surveys between Holes 6 and 7, a distance of nominally 10 meters. Other pairs of holes were surveyed in order to demonstrate that the tunnel can be seen over longer distances than 10 meters. Figure 21 shows a vertical section between Holes 6 and 9 cutting obliquely across the tunnel. Data is shown on two-foot vertical increments in the common-depth mode. The tunnel can clearly be seen between 160 and 168 feet deep. The file number is CS103.

Figure 22 is a vertical section between Holes 5 and 7, cutting across the tunnel at a right angle. The distance is nominally 20 meters. The tunnel is still clearly evidence from 159 to 165 feet deep. The file number is CS118. To get this data it was necessary to develop a new spark probe for the SX-7. This was discussed in the section on *Instrumentation*.

An attempt was made to transmit over 30 meters with the new probe. Signals were detectable but the signal level was too low to allow us to attempt to detect the tunnel. In more normal rock, such as the metamorphic rock encountered along much of the DMZ in Korea, it should be possible to see through over 30 meters.

# CSM62

File CSM62  
Transmit 02 Receive 04  
Start 150 End 190  
Time 30 sec

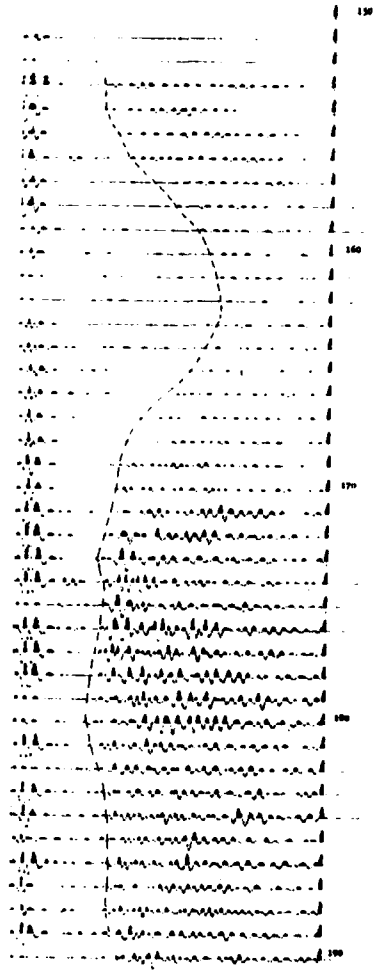

Figure 20. **Tunnel Detected through Ten Meters.** File CSM62 above was run between Holes 6 and 7, ten meters apart. The data is similar to that shown in the AFTER Section, Figure 19; but the sample points were one foot apart vertically, and the filter was set to a lower pass frequency.

# CS103

File CS103  
Transmit # 32  
Start 2:00  
Stop 2:05  
Time 50 sec  
Receive # 32  
Stop 2:05  
Time 50 sec

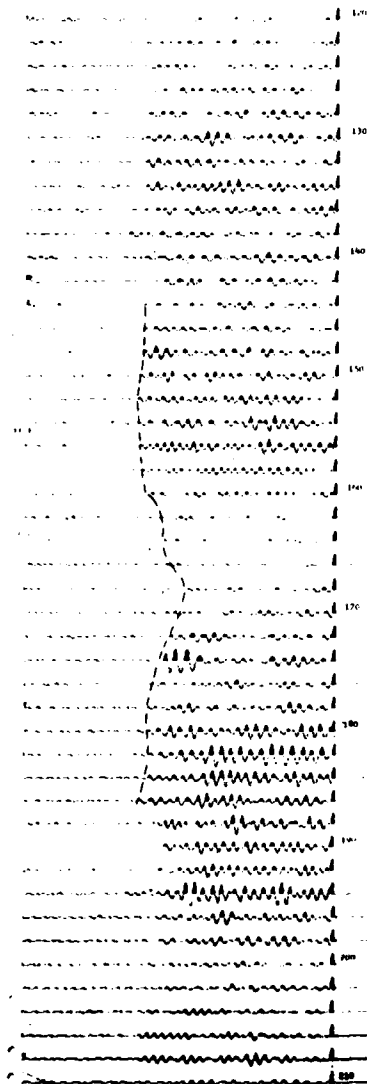

Figure 21. **Tunnel Detected through Fourteen Meters.** File CS103 was run between Holes 6 and 9 in the common-depth mode. The vertical increment is two feet.

# CS118

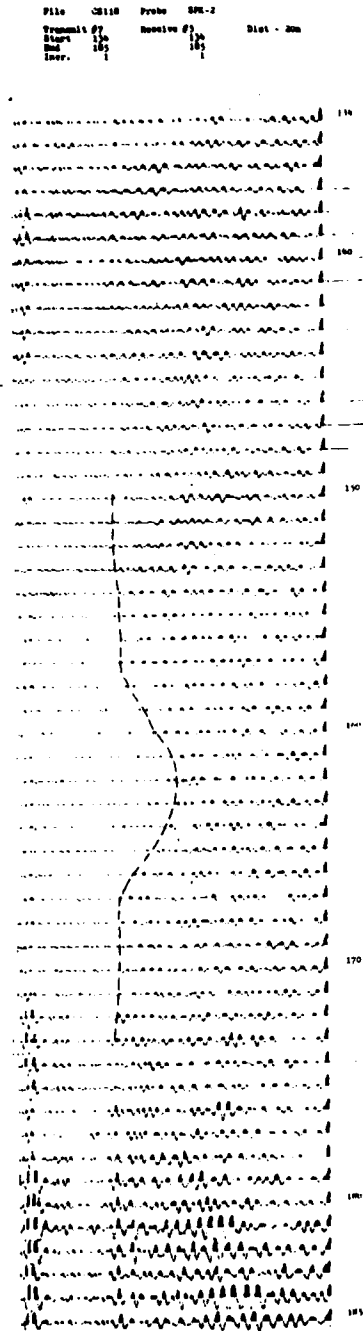

Figure 22. **Tunnel Detected Through Twenty Meters.** File CS118 was run between Holes 7 and 5, a distance of 20 meters. The Common Depth mode is used. Note the clear tunnel anomaly from 158 to 166 feet deep.

### **Tunnel Location**

Previously we have seen how a tunnel may be detected with the SX-7 borehole sonar. *Figures 19, 20, 21 and 22* show borehole sonar data in common depth sections. With these it was easy to determine that a tunnel, 8 to 10 feet high is located between Holes 6 and 7 (10 meters apart), between 6 and 9 (14 meters apart) and between 7 and 5 (20 meters apart). The tunnel roof is at about 157 feet deep, the tunnel floor is at about 166 feet deep.

In order to be able to drill into the tunnel we need better information on the lateral and horizontal position of the tunnel. This information can be obtained in much the same way as the earlier data. Instead of holding the transmitter and receivers at the same elevations, common depth mode, they will be offset some fixed vertical amount so that the sonic wave path is not horizontal, but is inclined either up or down. The tunnel will show up in this oblique section just as it did in the horizontal section, as a delay in the signal arrival time.

*Figure 23* shows two sets of crosshole data between Holes 6 and 7 with the receiver offset nine feet vertically from the transmitter. In *23 A* the receiver, in Hole 6 is nine feet lower than the transmitter in Hole 7. The lowest data record represents the transmitter at 172 feet and the receiver at 181 feet. In *23 B* the receiver is nine feet higher than the transmitter in Hole 7, thus the bottom data record is  $T=181/R=172$ . Sample points are every three feet vertically. Data are extracted from files CSM85 through CSM99.

In each of these oblique sections it is easy to determine the signal delay. The first arrivals have been connected with a dashed line to facilitate picking the center and outer limits of the tunnel anomaly.

On each section the center of the anomaly has been identified. The upper and lower limits of the anomaly have been selected. The exact location of the *outer limits of the anomaly is somewhat arbitrary*. Because of the distressed halo around the tunnel the anomaly is well over eight feet high. For the tunnel location exercise we have selected a point midway along the slope of the delay anomaly.

These sections, together with the appropriate common depth section may be used to determine the location of the tunnel horizontally between the two holes. *Figure 24* shows how this may be done. The solid lines are the upper and lower boundaries of the anomaly as determined from the common depth detection surveys. The dashed lines are the upper and lower anomaly boundaries as determined from the sections in *Figure 23*. By definition the tunnel must lie inside the area bounded by these limits, since outside of these limits there is little or no signal delay.

The location of the center of the anomaly may be estimated by drawing in the centerline as determined from each data section. Where these lines meet should be the center of the anomaly. The centerlines from the sections in *Figure 23* and in *Figure 20* are projected, and form a small triangle which should approximate the center of the anomaly.

As with any estimation, the accuracy and resolution increases with the amount of data used. *Figure 25* shows the projected centerlines from the common depth survey and 14 oblique surveys. The 14 surveys run from  $\pm 3$  foot offset to  $\pm 21$  foot offset and from  $+3$  to  $+21$  foot offset between the transmitter and receiver in increments of three feet. There are three locations where the centerlines converge. These are clustered within a five-foot circle. Since the sample points of the surveys were three feet apart the best resolution can only be three feet. The center of the tunnel should be in the triangle formed by points 1, 2 and 3 in *Figure 25*.

*Figure 25* also shows the cross-section of the anomaly as determined by plotting the upper and lower anomaly limits where these could be determined from the 14 oblique sections. The center point and the cross-section conform quite well.

The dashed square in *Figure 25* is an eight-foot by eight-foot tunnel drawn to scale and centered by the plotted center points. This represents the best estimate of the size and location of the tunnel.

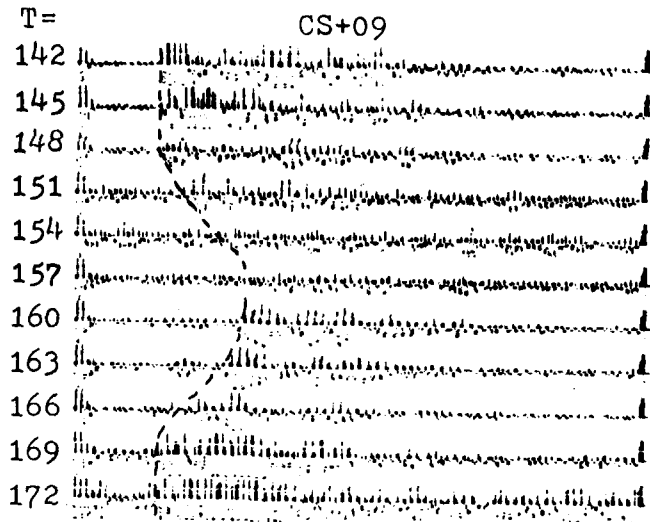

(A) CS+09 The receiver is 9 feet deeper than the transmitter ( $R = T + 9$ )

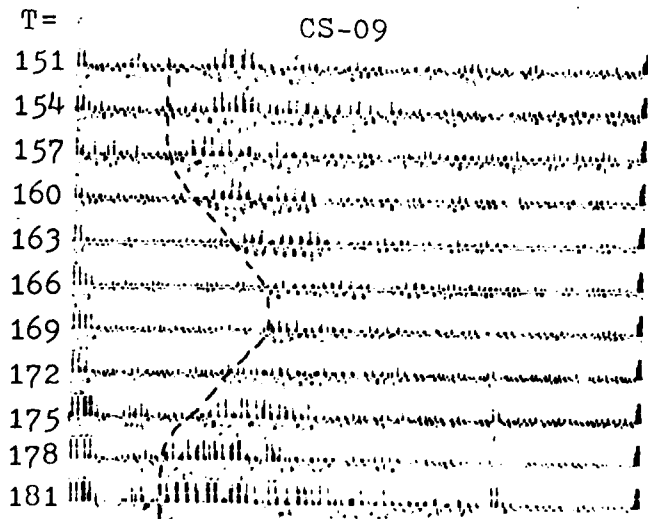

(B) CS-09 The receiver is 9 feet higher than the transmitter ( $R = T - 9$ )

Figure 23. **Vertical Offset Crosshole Data.** The receiver and transmitter are offset vertically and raised together up the holes.

**IDAHO SPRINGS**  
LOOKING EASTWARD (TOWARD THE PORTAL)

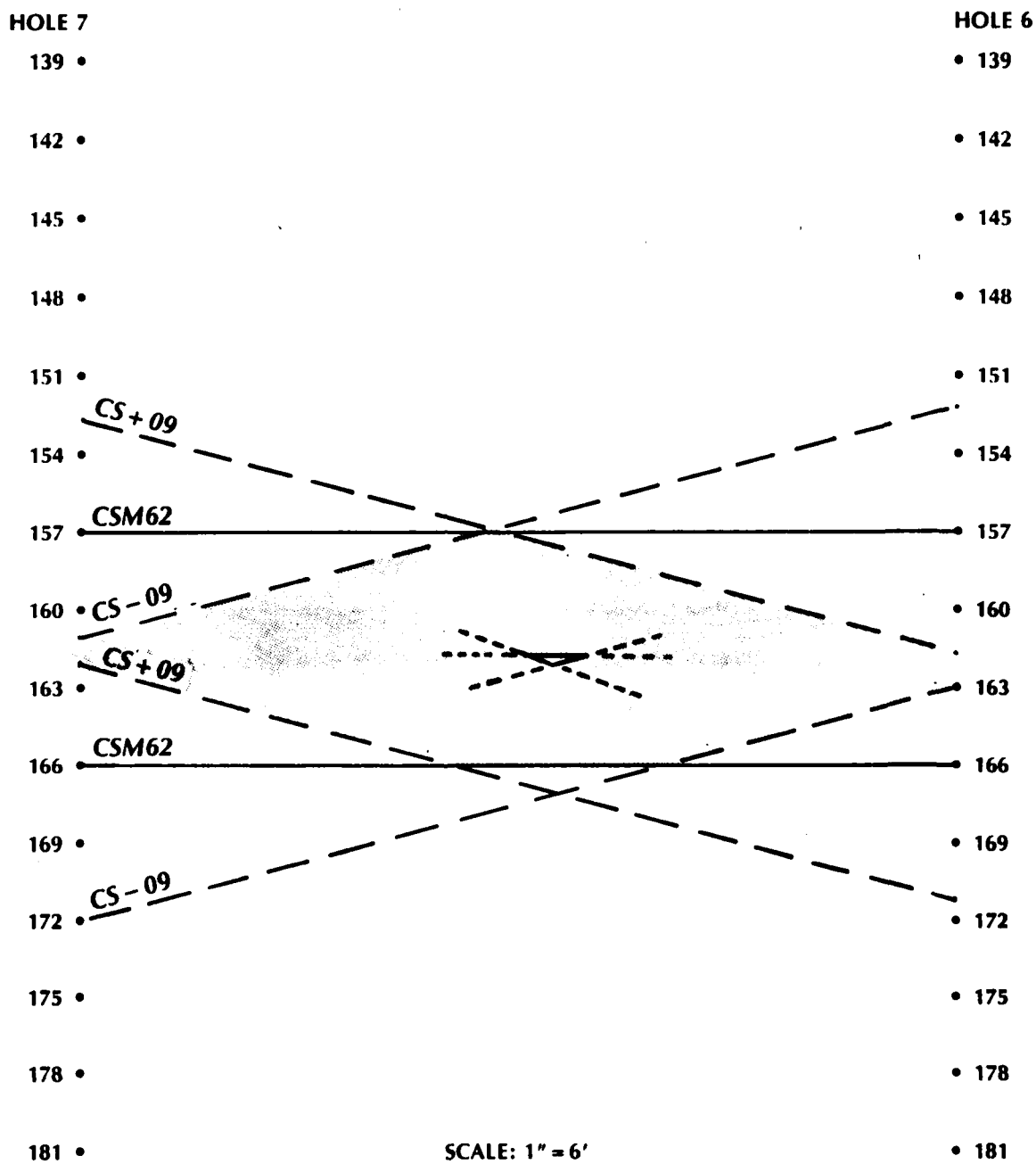

Figure 24. **Vertical Offset Method of Tunnel Location.** The dashed lines are the upper and lower limits of the anomaly area as determined by files CS+09 and CS-09 (Figure 23). The solid lines are from CSM62 (Figure 20). The triangle is the intersection of projected anomaly centerlines.



The tunnel was planned to be midway between Holes 6 and 7, and that is where we project it. What would happen if it were not midway between the two holes surveyed? Fortunately, we can find out because with the new SX-7 probe, borehole sonar surveys were conducted from Hole 5 to Hole 7, a distance of 20 meters.

The tunnel location data was derived in a slightly different manner, one which lends itself well to field reconnaissance and analysis. First, the common-depth mode survey was completed. The vertical location of the anomaly was determined. The transmitter was then placed in Hole 7 at 162 feet deep, approximately the center of the vertical anomaly. The receiver was then raised in Hole 5 from 190 feet to 138 feet, taking oblique angle data every foot. The resultant data section shows the shadow of the tunnel as if it were back-lighted by the transmitter at 162 feet. The angle subtended by the shadow is marked at Hole 7 as CS116 — the appropriate data file. Without knowing anything else about the target it has to fall somewhere between the two arms of angle CS116.

The receiver was then held stationary in Hole 5, first at 170 feet then at 162 feet, while the transmitter was traversed from 130 feet to 190 feet in Hole 7. The two angles formed by the tunnel shadow are CS115 and CS117 respectively. The target by definition must fall within the arms of each of these angles. The only area which satisfies the criteria for possible target location is the diamond-shaped shaded area.

To find the center of the area each of the sides of the diamond was bisected, and lines drawn connecting opposite centerpoints. Where these cross is the best estimate for the location of the anomaly center. The triangle is the location of the anomaly center as plotted in Figure 25. The coincidence of these calculated center points is definitive proof that the SX-7 can be used not only to detect tunnels, and other cavities, but also to locate the estimate the size and shape of the cross-section of the anomaly.

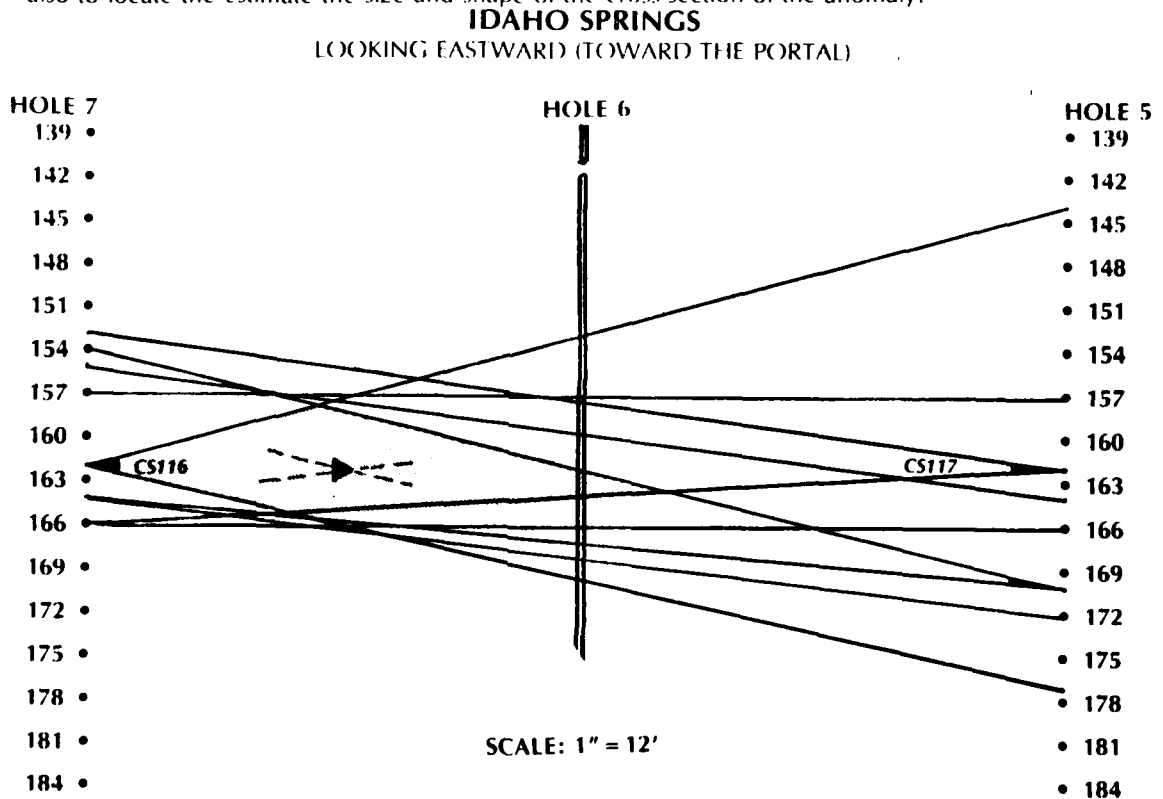

Figure 26. CSM Tunnel Located Through Twenty Meters.

### **Pulse-Echo Sonar**

The SX-8 pulse-echo sonar was used experimentally at Idaho Springs and at Manatee Springs. In each case the first step was to attempt to use the SX-8 piezoelectric transmitter in the crosshole mode. This is done to be sure that the 22 kHz energy will propagate through acceptable distances.

In both locations the rock conditions were too poor to permit transmission over even the minimum 10-meter spacing. Because of this we could not rely on the pulse-echo sonar because we did not know what the usable range would be.

The pulse-echo probes were used at Idaho Springs to gather data in Holes 6, 7 and 9, looking toward the tunnel and looking away from the tunnel in each hole. The results were studied in the field and later in Richland. There does not appear to be any useful data in these logs. The effective range of the high-frequency pulse-echo system in low-velocity, fractured rock is too short. Files CS120 through 128 contain the data from the pulse-echo trials.

### **Velocity Determinations**

A separate part of the Idaho Springs investigation was a requirement to measure P-wave and S-wave velocities and to calculate Poisson's Ratio from the resultant data. Data measurements were taken in one-half foot increments between six pairs of holes. Data measurements were made from the bottom of the holes to as close to the surface as possible. In the top 50 to 100 feet the weathered rock and soil, together with a lack of water in the holes, precluded transmission of crosshole signals. Arrival times were measured with the probes in the common-depth mode.

Velocity determinations were made using the DATAANAL software developed for the purpose by SONEX. This program permits the analyst to call up several sequential data records on the video monitor. The hole-to-hole separation is entered by keyboard. Provisions are made to enter the hole-to-hole distances at different elevations if hole deviation surveys have been made. The computer will distribute the distance change uniformly between recorded distance measurement points. The analyst selects the P-wave arrival time for the first record by moving a cursor on the screen with the graphic control paddle and enters this point into the computer by pressing a control button. He then selects the S-wave arrival time in a like manner and enters it into the computer. He then proceeds to the next data record and performs the same steps.

When all of the records displayed on the screen have been evaluated a new set of records is called up and evaluated in a like manner. When an entire file has been completed the P- and S-wave times, which had been held in a matrix, are used to calculate the appropriate  $V_p$  and  $V_s$  values for each one-half foot and to calculate the ratios  $V_p/V_s$  and Poisson's Ratio. These data, together with the transmitter and receiver depths and the detected arrival times are printed on the graphic printer.

Figure 10, page 19, shows an example of the output of the DATAANAL program on a short section of crosshole data. Note that even though the transmitter and receiver became further apart with each record, the distance compensation segment of the program corrects for this deviation. The  $V_p$  and  $V_s$  calculations are included in Appendix A to this report.

## MANATEE SPRINGS, FLORIDA

### **Site Description**

The Manatee Springs field program was conducted at Manatee Springs State Park, on the Suwanee River near the west coast of Florida. The geology is typical of coastal Florida: flat-bedded limestones, highly fossiliferous, generally soft and permeable. The combination of abundant moisture, salt and fresh water interfacing, and soft rock leads to karstic development including sinkholes, caves, underground springs, and similar phenomena. Sonic velocities range from a low of 5,000 fps to a high of 13,000 fps.

A major underground watercourse is present at Manatee Springs. The spring proper is a sinkhole where the main watercourse ends. An estimated 116,900,000 gallons of fresh water pour out of the cave system daily, "boiling" up in the spring and flowing away to the nearby Suwanee River. Divers have mapped portions of the main underground channels, and they assisted in the investigation of this site by mapping parts of an auxiliary channel to be explored by drilling and geophysics.

This part of the borehole sonar program was conducted under the auspices of the U.S. Army Corps of Engineers, Waterways Experimental Station (WES). In preparation for the program, WES mapped a branch of the main channel and drilled a line of four holes spaced roughly 20 feet apart and straddling the branch channel. A fifth hole was drilled about 70 feet to the northeast along the trend of the branch channel. *Figure 27* shows the layout of these holes, C-1 through C-5.

Manatee Springs proved to be an ideal site for cavity detection experiments with the borehole sonar. The terrain was flat. Access to the site and holes was easy. All holes were filled with water to within a few feet of the surface. The site is located in a Florida state park, and the cooperation and support of the park rangers contributed greatly to the conduct of the program.

### **Field Activities—1980**

Borehole sonar surveys were conducted in several pairs of boreholes. *Table 5* identifies the data files and the holes used. Work was conducted from July 28 through August 1, 1980.

Preliminary geologic sections were provided by WES prior to the start of the program. The assumed location of the branch channel, as well as smaller cavities encountered in the drilling, were shown on these sections. The branch channel extends NE-SW between boreholes C-2 and C-3. The assumed depth to the top of the cavity was 105 feet, and it was believed to extend down to 115 feet.

Since it was believed that the cave was in the interval from 105 to 115 feet deep, most of the emphasis in subsequent surveys was placed on that section of the boreholes. Fanned surveys were run from 100 to 120 feet deep.

The first survey, conducted on July 28, 1980, was between boreholes C-3 and C-4 and is shown in *Figure 27*. P-wave velocities ranged from 6,000 fps to 13,000 fps. The higher velocity occurred in a ledge about 80 feet deep near the Ocala-Williston contact. This ledge was seen in each crosshole survey that had data up to 80 feet.

The second survey was run in holes C-2 and C-3, which are on opposite sides of the cave. From 106 to 114 feet the transmission was reduced to almost nil. Because the cave was expected to be exactly in this interval, and because small cavities had been noted about 115 feet deep in the logs for holes C-2 and C-3, it was assumed that the lack of transmission was the result of lost signal strength at the boundaries of the cave.

(In more competent, denser rock the effect of a cavity is a reduced signal amplitude and delayed signal arrival time.)

**TABLE 5**  
**MANATEE SPRINGS — DATA FILES**  
**1980 AND 1981**

DATE	FILE #	HOLE #		— T/R POSITION —			FILTER (kHz)	TIME (MS)	REMARKS
		X'MIT	REC	FROM	TO	SPACE			
<b>1980</b>									
July 28	MSF01	C3	C4	68-68	158-158	2-2	2-8	10	23 feet
July 29	MSF02	C3	C2	50-50	160-160	1-1	2-8	5	33 feet, includes cave
July 29	MSF04	C3	C2	83-83	121-121	2-2	2-8	10	
July 30	MSF05	C3	C2	87-125	125-125	2-0	2-8	10	
July 30	MSF06	C3	C2	106-120	120-120	2-0	2-8	10	
July 30	MSF07	C3	C2	120-120	120-106	0-2	2-8	10	
July 30	MSF08	C3	C2	100-100	115-100	1-0	2-8	10	
July 30	MSF09	C3	C2	100-100	100-114	0-1	2-8	10	
July 30	MSF10	C3	C5	100-100	124-124	2-2	2-8	10	48 feet, part of cave
July 31	MSF11	C4	C5	100-100	136-136	2-2	2-8	20	41 feet, part of cave
July 31	MSF15	C4	C1	90-90	150-150	**	2-8	20	89 feet, includes cave
July 31	MSF16	C4	C1	10-10	100-100	10-10	.8-8	20	
Aug. 1	MSF17	C4	C1	100-100	130-130	2-2	.8-8	20	
Aug. 1	MSF18	C4	C5	130-130	160-160	10-10	.8-8	20	71 feet
Aug. 1	MSF20	C3	C2	86-118	120-118	2-0	.8-8	10	
Aug. 1	MSF21	C3	C2	96-116	120-116	2-0	.8-8	10	Fan pattern
Aug. 1	MSF22	C3	C2	96-114	120-114	2-0	.8-8	10	
Aug. 1	MSF23	C3	C2	100-108	120-108	2-0	.8-8	10	
<b>1981</b>									
Oct. 20	MSF50	C3	C4	52-52	110-110	1-1	2-8	10	
Oct. 21	MSF51	C2	C5	59-59	120-120	1-1	2-8	10	
Oct. 21	MSF52	C2	C3	69-69	130-130	1-1	2-8	10	
Oct. 21	MSF53	C2	C3	98-120	98-80	0-1	2-8	10	
Oct. 21	MSF54	C2	C3	120-98	64-98	1-0	2-8	10	
Oct. 21	MSF55	C1	C5	69-69	128-128	1-1	.8-8	20	89 feet
Oct. 21	MSF56	C1	C2	70-70	130-130	1-1	.8-8	40	
Oct. 21	MSF57	C1	C3	70-70	130-130	1-1	.8-8	40	
Oct. 21	MSF58	C1	C4	69-69	130-130	1-1	.8-8	40	89 feet

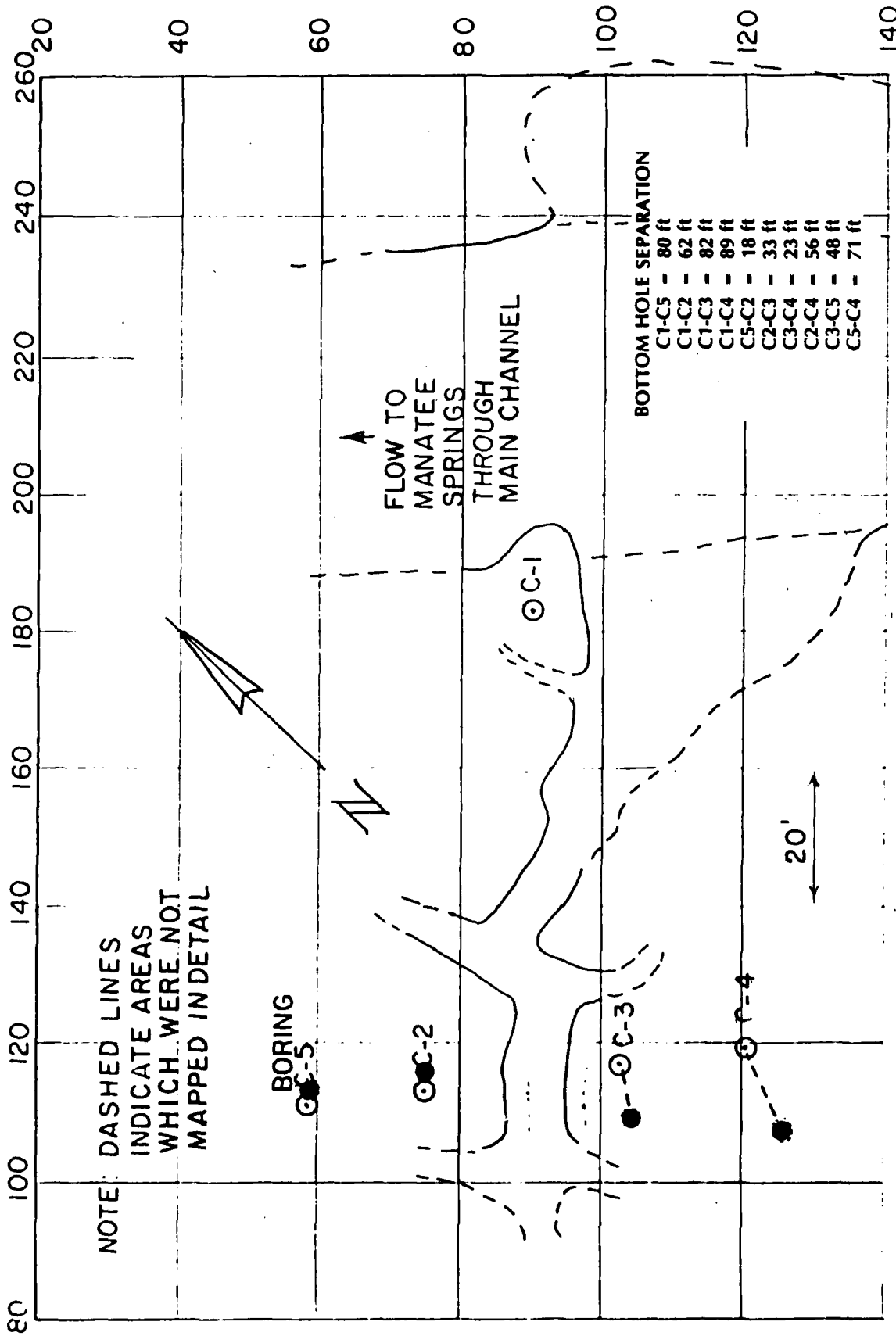

Figure 27. Borehole and Cavity Map — Manatee Springs. Borehole layout and cavity location mapped by divers. Solid circles indicate approximate location of the bottoms of the boreholes according to borehole deviation surveys.

MSF01

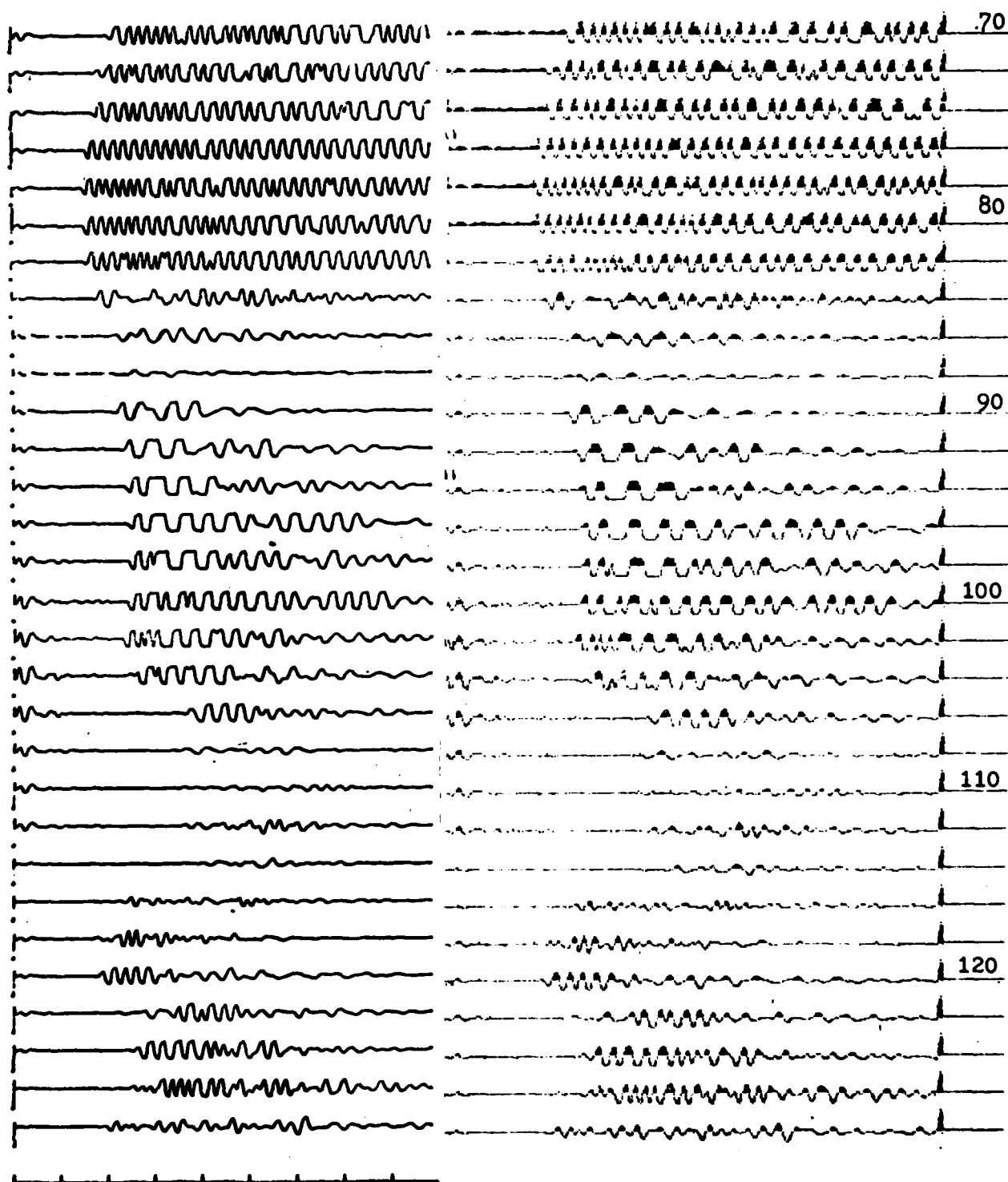

Figure 28. Crosshole Section C-3 to C-4. Crosshole data taken with the transmitter in borehole C-43 and the receiver in borehole C-4. Apparent P-wave velocities range from 16,000 fps at 80 feet deep to 6,700 fps at 110 feet deep. Data file is MSF01. A is plotted on an X-Y plotter, B is the same data plotted on the graphics printer and photographically reduced to the same scale.

Two crosshole surveys run in 1980 are shown in *Figure 29*. Both surveys cross the water-filled cave. MSF04 was run between Holes C-2 and C-3, a distance of about 33 feet. MSF10 was run between C-3 and C-5, a distance of about 48 feet. Based on what was later learned about the location of the cave, the relatively strong signals received through the section from 93 to 105 feet were thought to be strong because of the low attenuation associated with the water.

In comparing the signal character, frequency, and noise, there is a significant difference between the crosshole signals in the vertical section from 99 to 105 feet deep and the crosshole signals in the vertical section from 117 to 124 feet although the arrival times and amplitudes are similar. We speculated that the difference is caused by the upper set of signals passed through the water-filled cavity, and the lower set being essentially in rock all the way. Unfortunately, this signal difference was not apparent until the data records were plotted together. Because the cave was thought to be 10 to 15 feet lower than it actually is, not enough attention was paid to this section of the holes in the 1980 program.

Data files MSF04 through MSF09 and MSF20 through MSF23 are fan patterns centered around the assumed cave location. Files MSF10, 11, 15-17 and 18 are surveys between pairs of holes up to 89 feet apart to determine the range of the SX-7 in low density rock.

The success in being able to transmit through approximately 89 feet of low-density rock, with an apparent P-wave velocity of 10,000 fps or less, was gratifying and somewhat unexpected. What is equally interesting, in light of the apparent difference in signal characteristics seen in *Figure 29*, is a corresponding difference seen in MSF17. The signals seen at 100-106 feet are a greater amplitude even though they arrive later. Referring to the borehole map, *Figure 27*, it can be seen that 30% to 40% of the distance from C-3 to C-1 at the 100-foot elevation may be through the water-filled cave. Again, it is possible that there is a characteristic signature for the water-filled cavity transmission. During the 1980 field program, this part of the boreholes was not thoroughly studied. It would have a more detailed examination in 1981.

#### **Field Activities—1981**

Data received in January 1981, from a new hole (E-1) drilled into the cave shows that the assumed cave elevation was incorrect. The cave actually starts at about 92 feet deep, pinches down at 98 feet deep and swells again extending to 107 feet deep. Because the 1980 field work had concentrated on a lower section of the holes, we returned to Manatee Springs in October 1981 to restudy the holes.

We had also intended to use the new E-1 hole for pulse-echo cavity-sounding experiments with the SX-8 and crosshole experiments from inside the cave to a hole outside of the cave. Unfortunately the hole was not kept open, and these parts of the planned program could not be done.

The 1981 field work was done during the week of October 18 through 23, 1981. The equipment used was the same as used during the 1980 field program.

Data files MSF50, 51 and 52 are data from surveys between the four holes in a line crossing the cave. MSF55, 56, 57 and 58 are data taken with the transmitter probe in the offset hole and the receiver in each of the in-line holes in turn. MSF52, 53 and 54 complete the fan patterns in the upper part of the cave anomaly.

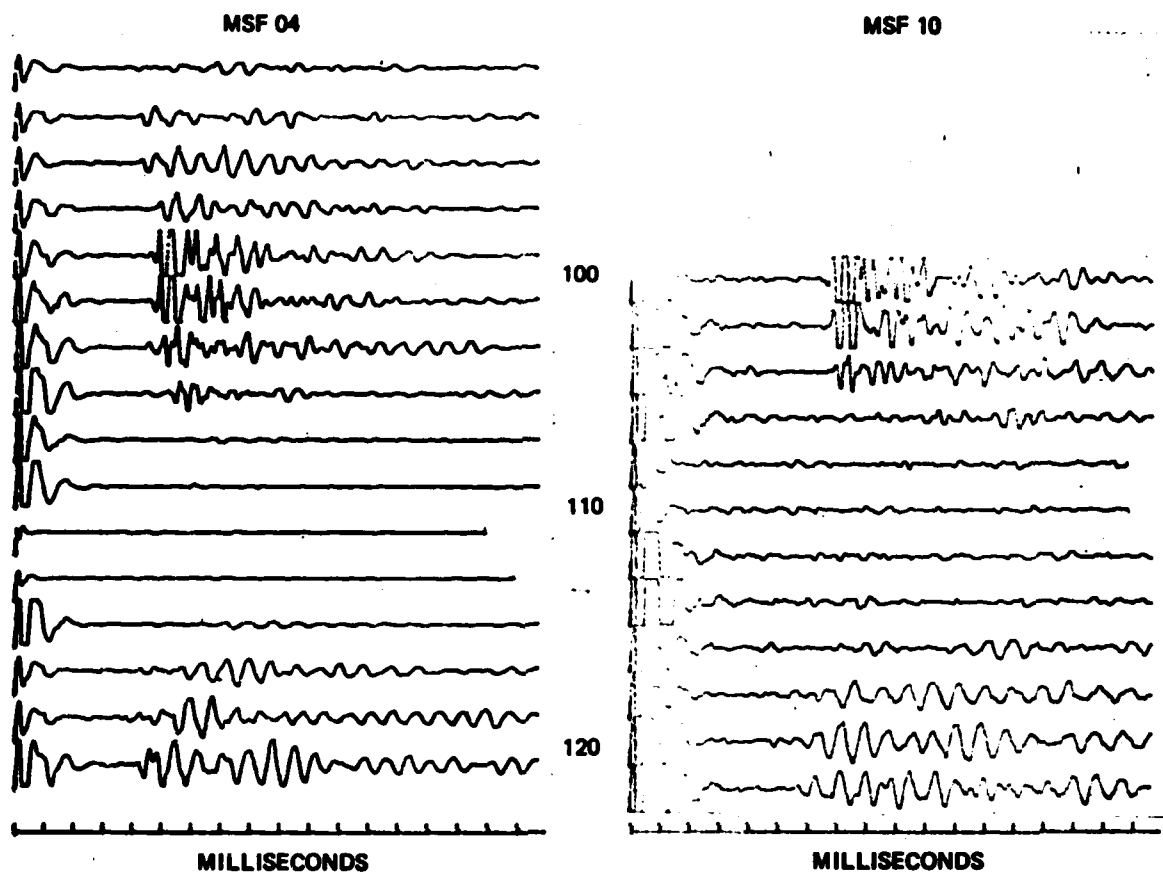

Figure 29. **Crosshole Section C-2 to C-3, and C-2 to C-5.** Two crosshole surveys that apparently show the effects of transmission through a water-filled cave in low-density rock. Survey MSF04 was run with the transmitter in C-3 and the receiver in C-2 separated by about 33 feet. For survey MSF10, the receiver was moved to C-5, a separation of about 48 feet. Borehole C-2 is on one side of the cave; boreholes C-3 and C-5 are on the opposite side. It is interesting to note the difference in the signal character between the 93-105 foot section and the 118-124 foot section. The 1981 field work indicates this signature is distinctive of a water-filled cave.

#### **Representative Data**

Figure 28 is the first survey run at Manatee Springs, MSF01. The transmitter was in C3 and the receiver in C4. The separation between holes is 18 feet at the collar and 23 feet at the bottom of the hole. These files are shown plotted on the X-7 plotter and on the graphics plotter for comparison.

Figure 30 is a composite section using data from files MSF50, 51 and 52. The section is along the line of holes C5, C2, C3 and C4 which crosses the cave (between holes C2 and C3). The differences in the character of the rock are startling.

Figure 31 is a composite using data from files MSF55, 56, 57 and 58. The transmitter in each case was in hole C1. The receiver was in hole C5, C2, C3 and C4 from left to right. The distances between holes are 80 feet, 64 feet, 82 feet, and 89 feet respectively. The vertical increment plotted in Figures 28, 29 and 30 is two feet.

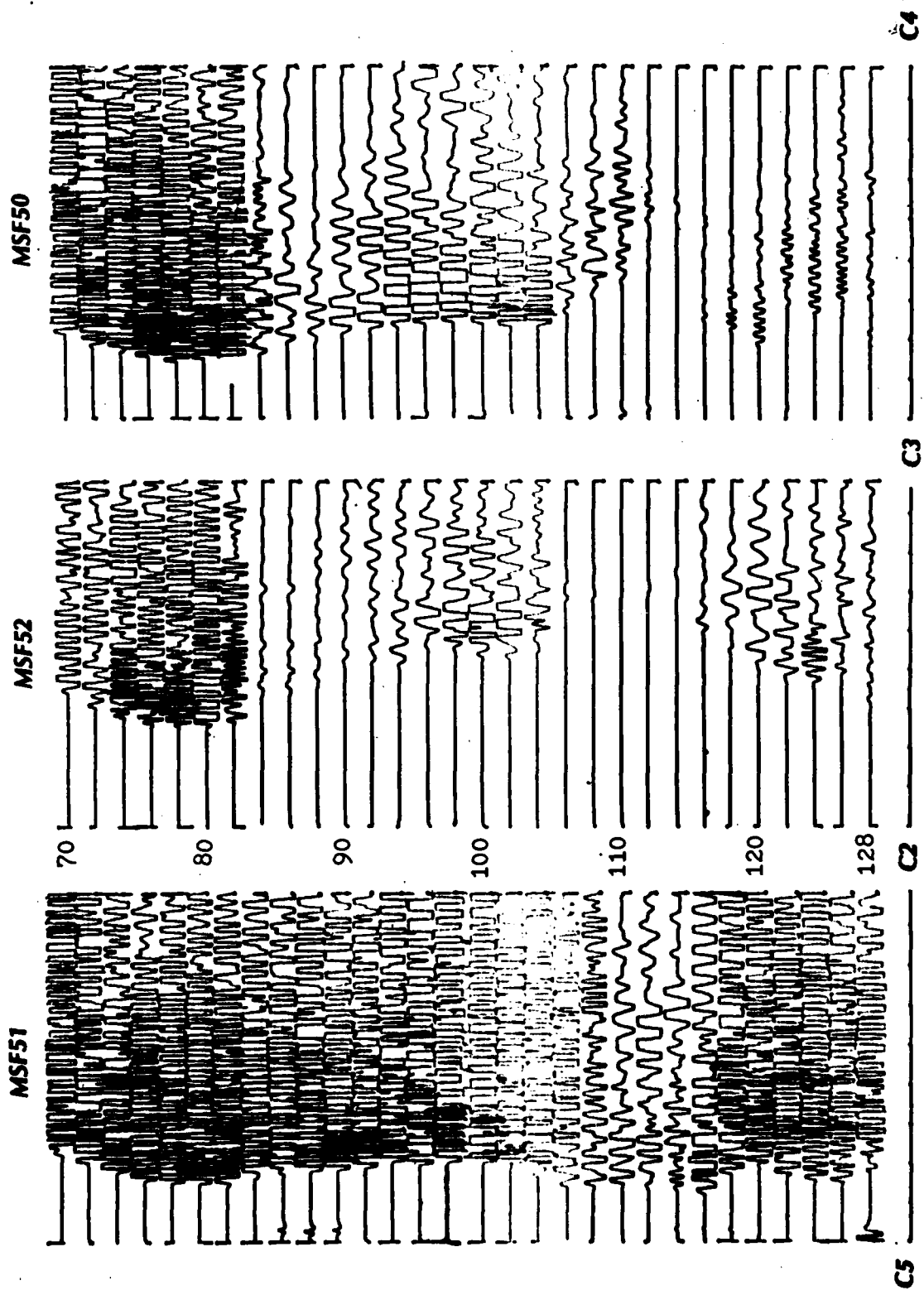

Figure 30. Composite Section Across Cave Area. The data files used are MSF51, 52, and 50 from left to right. The cavity detected by the divers extends from 92 to 105 feet in the center section. Note the strong refracted signal pattern at this point. Also note that a similar pattern occurs, reversed, in the right-hand section. This may indicate a hitherto unknown section of the cave system.

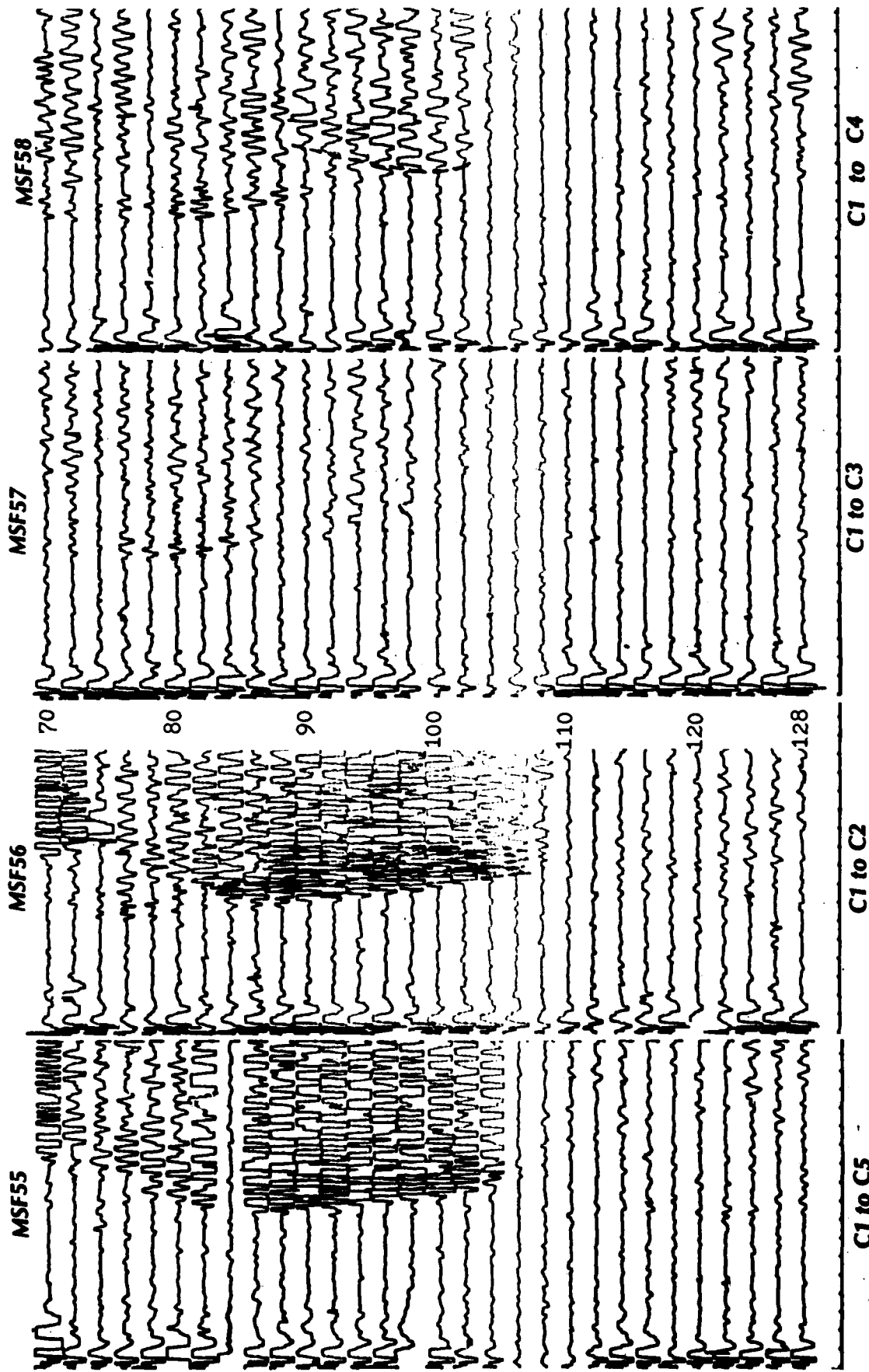

Figure 31. Composite Section from C-1 to C-5, C-2, C-3 and C-4. These sections cover distances of 80, 62, 82 and 89 feet respectively. The water-filled cavity signature can be seen in MSF58. This covers the same section as seen earlier in Figure 29.

### **Cavity Detection**

The presence of a cavity, void, or tunnel normally shows up as a delay in the crosshole signal arrival, and some reduction in signal amplitude. This is because the sonic velocity of the cavity-fill, whether air, water, or mud is normally much lower than the sonic velocity of the surrounding rock.

At Manatee Springs the situation was different. The sonic velocity of the soft limestone rocks in the vertical section containing the cave ranges from 5000 to 7000 feet per second. Since the sonic velocities of the rock and the water in the cave were very similar, there was no appreciable signal arrival time difference. Furthermore, since the water in the cave was a better transmission medium for sonic energy than the soft, vuggy rock, the signals received through the cave area were stronger than those which traveled through the rock above and below the cave.

Figure 32 is file MSF52 between Holes C2 and C3, crossing the known cave. The cave extends for 92 feet to 107 feet. Below the cave there is a zone of soft rock with many small cavities and openings. This zone, from roughly 100 to 116 feet may represent the main aquifer. This is the vertical section with uniformly the poorest sonic transmissibility.

The signals seen in the vertical section corresponding to the cave are distinguished by a change in frequency from the normal and relatively high signal amplitude as was noted in the brief examples seen in 1980. The most distinguishing feature is the flat convex (viewed from the transmitter) pattern centered at 98 feet and traceable above this point to 88 feet and below this point to 109 feet. The uniformity of the pattern, coupled with its coinciding with the known cave section are empirical proof that this signature indicates a water-filled cave.

One possible explanation is that sound waves hitting the cavity wall are radiating through the water as if from a point source. They then travel a longer path from transmitter to receiver, but because of the lower attenuation of the water are arriving at the receiver with greater peak power than the straight through signals.

A second consideration is that the convex wave pattern is what one would expect if a plane were passed through a plane-concave or concave-convex lens. Although the cave is known to pinch in at 98 feet it seems too much of a coincidence that this change in the width of the cave is uniform enough to explain the very regular convex pattern. The first hypothesis seems more likely.

In any event the signals are distinctive enough in frequency, amplitude, and pattern as to be used as a guide to cave detection. This combination may also be seen in Figure 31, file MSF57, the section from C1 to C3 which intersects the cave.

From C1 to C4 in the same figure the pattern is not discernable, possibly because the ratio of rock to water in the crosshole path is significantly greater; Perhaps simply because the lower signal to noise ratio in MSF58 obscures the pattern.

This distinctive pattern is totally absent from file MSF51, the section between C2 and C5 a distance of about 19 feet. Figure 33 shows that this section has uniformly good transmission, even in the supposed aquifer zone the  $V_p$  is high and a good signal level is detected.

However, File MSF50 in Figure 34 provides a very interesting picture in light of what was seen in Figure 32. From 88 feet to 104 feet a shallow concave parabola is seen, reversed from the direction of the pattern in Figure 32. This pattern of arrivals occurs close to but not simultaneously with the first arrival. At the top and bottom of the parabola it is the first arrival. In the center it traces the first arrival by up to one-quarter millisecond. Figure 35 is an enlargement of this section showing the time relationship of the signals in better detail.

In addition, a convex pattern is seen starting from 81 feet to 96 feet where it intersects the previously mentioned concave pattern. The interference pattern formed by these two patterns is apparent in the trailing signals from 95 to 105 feet.

The implication to be gained from this section of data is that there may well be an unrecognized arm of the cave system which extends between C3 and C4 at roughly the same elevation as the one recognized between C3 and C2. If so it may be even larger, in width than the original cave, and extend higher up in the section.

File: B2P1      Probe: CR-1  
Transmit # 2      Receive # 1  
Start    50           50  
End     130           130  
Incr.    1           1  
Time    10.00

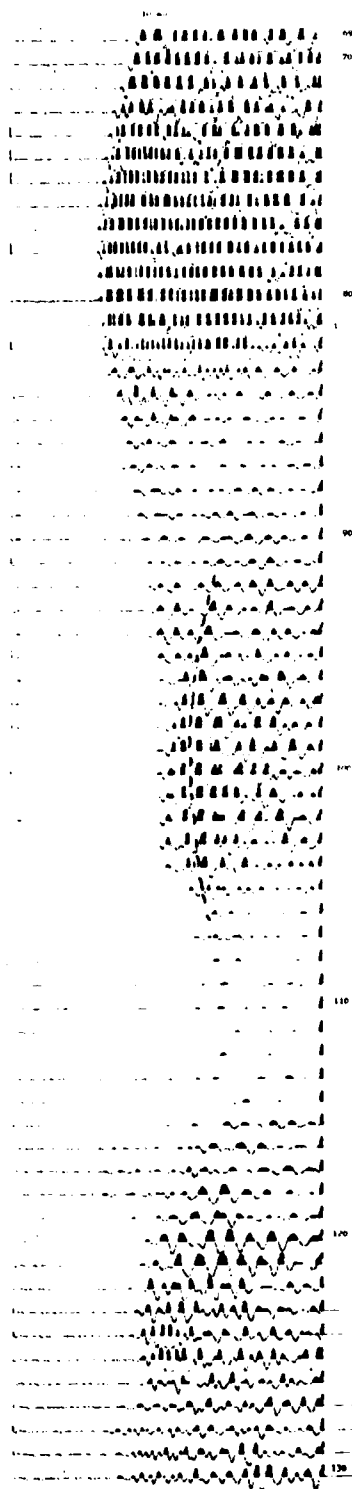

Figure 32. **Crosshole Section C-2 to C-3.** This section shows the cave signature as a convex parabola between 92 and 106 feet. The zone below the cave is soft rock with abundant small cavities.

Figure 33

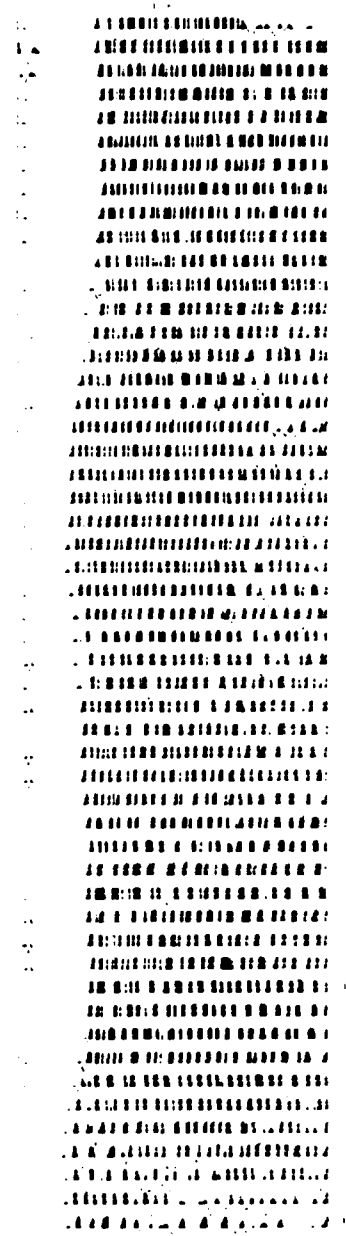

Figure 33. Crosshole Section C-2 to C-5.

File No. 100-100000-1  
Transmit to: Director  
Date: 10/10/50  
Page: 10  
Time: 10:00

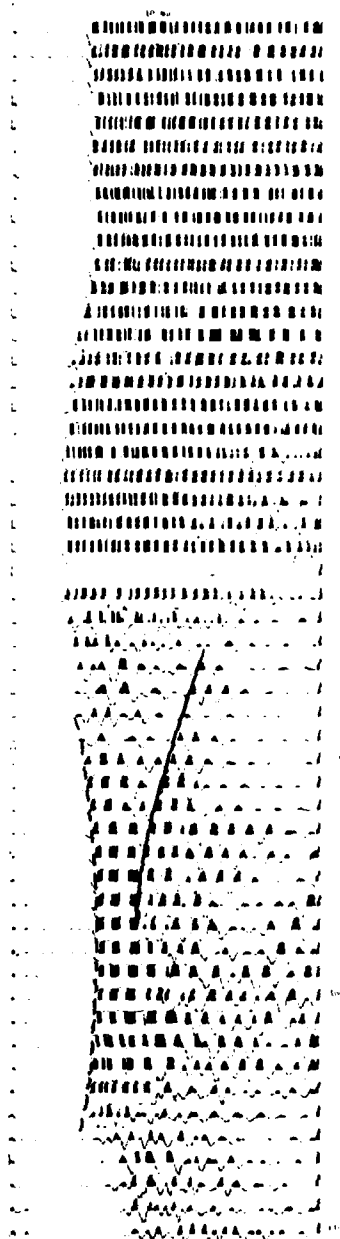

Figure 34. Crosshole Section C-3 to C-4.

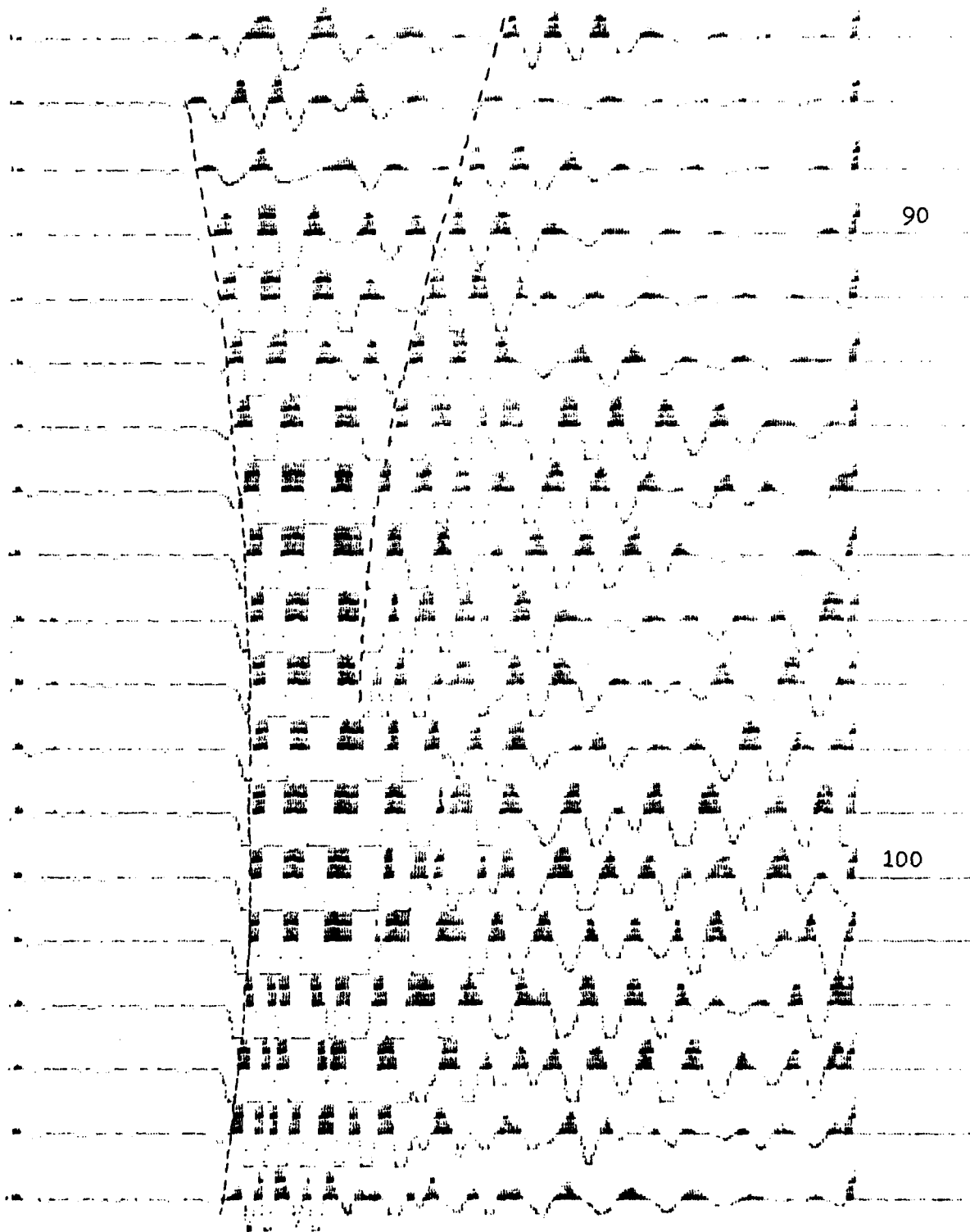

Figure 35. **Crosshole Section C-3 to C-4, Enlarged.** Note the convex and concave parabola and the apparent phase reversal on the first arrivals from 84-88 as compared with the arrivals from 90-106.

### **Cavity Location**

The cave has been detected. It is determined to run from 92 feet to 105 feet deep from the data shown in *Figure 32*, the common depth crosshole survey. We now need to know where it is horizontally between C2 and C3.

We will use the same techniques used to define the tunnel location at Idaho Springs. After establishing the upper and lower anomaly limits with the common depth survey the transmitter is placed approximately in the center of the vertical zone, at 98 feet deep and the receiver is scanned down the opposite hole from 80 to 120 feet. The upper and lower limits of the cave "shadow" are marked off and plotted in *Figure 36*. (In this case the "shadow" is the zone in which the distinctive water transmission signals can be seen.) The receiver is then moved to 98 feet in its hole and the transmitter scanned from 80 feet to 120 feet and the detected limits transferred to the plot. File MSF53 and MSF54 contain those data.

We have additional data from the 1980 field program in the form of fan patterns which help to define the lower limits of the cave. These are contained in files MSF08, 09, 10, 21 and 23.

All of these data have been plotted in *Figure 35*. The source of each plotted line is noted. The diamond shaped area defined by the shadow lines must contain the cave. We do not have enough information to describe the width of the cave. The rock and water  $V_p$  values are so close that there is no significant delay of the signal.

The irregular cross section plotted on *Figure 36* is the cave cross section as drawn by WES from data supplied by divers. The cave outline conforms well to the sonar location data.

There is information in the form of interference patterns and refraction patterns which could lend itself to advance processing using holographic interpretation. This concept is one which has been used experimentally by the Bureau of Mines and other researchers, including the author, and offers promise for extracting more useful data out of sonic signal suites.

MANATEE SPRINGS  
LOOKING NORTHEAST

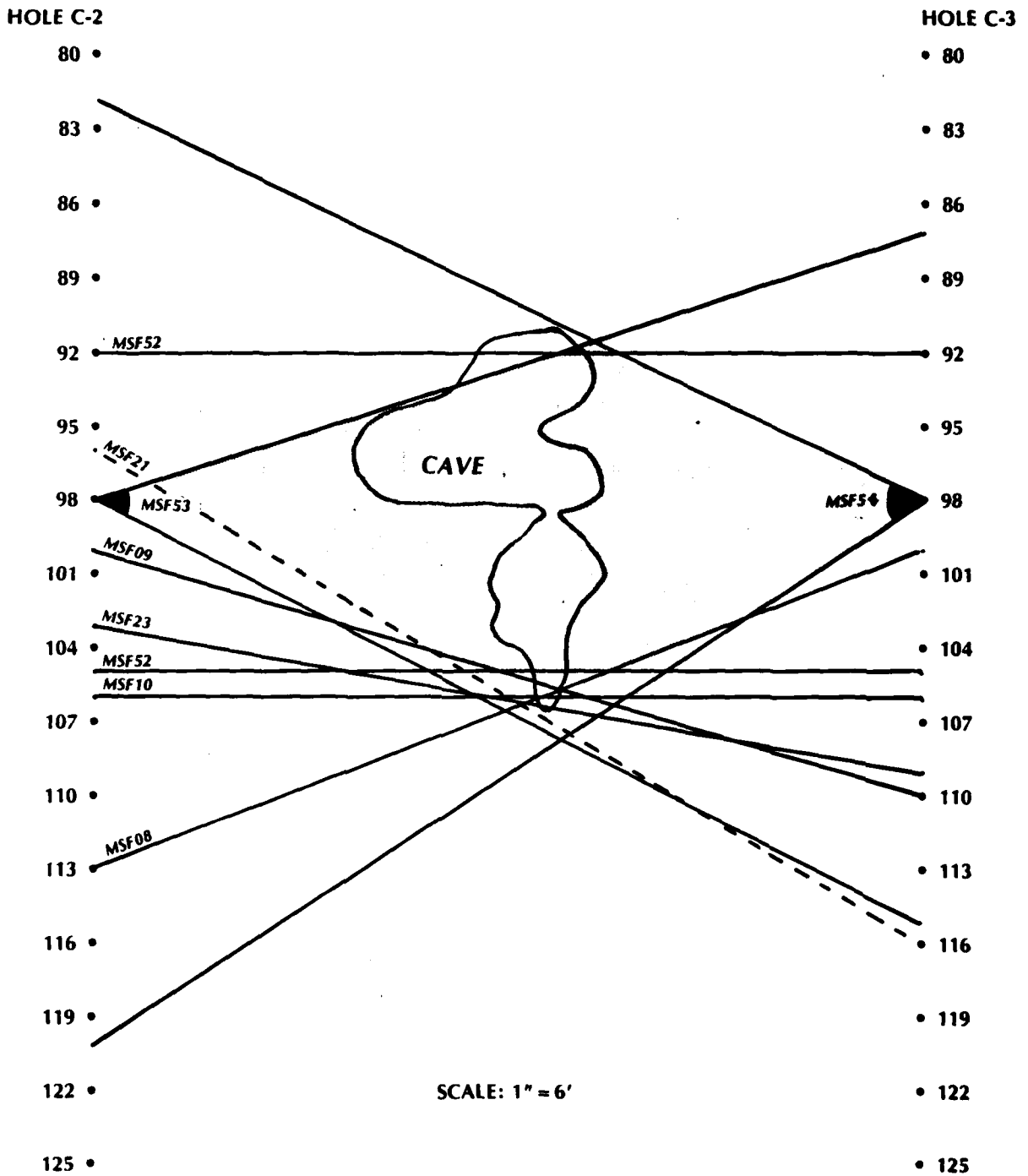

Figure 36. **Cave Location by Borehole Sonar.** The sonar data located the cave within the shaded diamond shape. The cave cross section shown is plotted from data provided by divers to the Corps of Engineers.

## Conclusions

The demonstrations of the SX-7 borehole sonar for detection and location of air-filled tunnels were successful. The eight-by-eight foot tunnel driven at the Colorado School of Mines Test Site at Idaho Springs was easily seen in the common-depth crosshole sonar surveys.

The tunnel could be detected when the hole-to-hole spacing was 10 meters, when it was 14 meters, and even when it was 20 meters. At 30 meters separation, the received signal-to-noise ratio was so low that no useful tunnel detection data could be seen.

Comparisons of the data with data from sonar surveys in 1980, before the tunnel existed, gave positive proof that the anomalies seen in 1981 are directly caused by the tunnel, not by geologic phenomenon.

The size and location of the tunnel between pairs of holes could be determined using the SX-7 in the offset depth mode, and by plotting the tunnel "shadow." The tunnel limits were plotted in one case when the hole-to-hole separation was 10 meters, and in one case where the separation was 20 meters. The center of the anomaly was also plotted for each case. The plotted limits coincided well, although the limits were better defined in the short spacing example since there was more data to work with. The plotted center points from the two cases coincided perfectly.

The SX-8 pulse-echo technique could not be demonstrated. The rock at both Idaho Springs and at Manatee Springs was too attenuative to the higher frequency sonic energy. Suitable pulse-echo ranges could not be achieved.

At Manatee Springs the SX-7 clearly detected the water-filled cave which was previously mapped by divers. The vertical depths of the sonar anomaly coincide well with the mapped depths. A second cave area was detected in an area where no cave had previously been recognized or mapped.

The location and size of the first cave cross-section was plotted using the anomaly shadow method. Time did not permit full investigation of the second cave anomaly.

Experiments with the sonic transmitters of the SX-7 showed that the useable power output and output frequency can be varied by changes in the physical chamber design and in the spark-circuit design. Increases up to five times the power of the original system were demonstrated. Further experimentation and design changes may be expected to provide further increases.

Velocity determinations at Idaho Springs were made by visually picking the P-wave and S-wave arrival times. Data was measured at one-half foot intervals and the results presented in Appendix A.

The results conclusively demonstrate that the SX-7 borehole sonar provides a valuable tool for tunnel and cavity detection and location.

## Recommendations

Demonstration of tunnel detection and location and of cave detection and location has been successfully performed. The equipment used for these demonstrations was the prototype SX-7 borehole sonar by SONEX.

The system is ready to be deployed in the field to complement and support other tunnel detection methods.

Further effort should go into three areas:

### 1. Development of Geophysical Signatures

The experience at Manatee Springs showed that certain types of target anomalies have characteristic signatures. The pattern formed by the water-filled cave is distinctive and easily recognizable. Added cavity detection experience at a wide variety of sites and geologic environments should be acquired with a view to cataloging the characteristic signatures of different situations. This information will be most useful in aiding the analyst in describing detected anomalies.

Deployment of one SX-7 system with a tunnel detection team in an actual search operation will be one way of gaining additional experience.

### 2. Develop New Source Designs

The piezoelectric and spark transmitter of the SX-7 are suitable for a variety of situations. Tests have shown that changing the electric circuitry of the probe, and changing the physical dimension of the spark chamber can dramatically affect the probe performance.

Experiments should be made with new source designs to evaluate potential improvements in frequency, amplitude and signal duration. The goal is to optimize transmissibility without losing resolution.

### 3. Holographic Analysis

The received data from Manatee Springs showed interference patterns and phase-shifted data similar to that derived from a through-transmission hologram. It can be plainly seen that the pattern is caused by the refraction and reflection of the pseudo-plane wave as it passes through the target cave. As such the pattern must contain information describing the cross-sectional shape of the cave.

Holographic image analysis is capable of decoding these interference patterns. Experiments done by the Bureau of Mines and other researchers have shown that these techniques can be used successfully in geologic investigations. This interpretive method should be explored.

DATE  
FILMED  
7-8