

APPLIED

1 OF 5
AD
A115 131

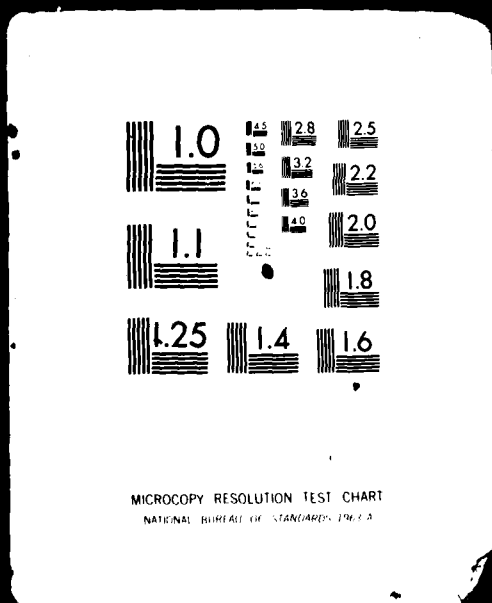

MICROCOPY RESOLUTION TEST CHART
NATIONAL BUREAU OF STANDARDS-1963-A

2

AD A115131

DESIGN STUDY FOR
MOUNTING THE CLASS 30
MEDIUM ARMORED VEHICLE LAUNCHED
BRIDGE AND LAUNCH MECHANISM
ON A SUITABLE TRAILER

WILLIAM P. HIDDEN
ARTHUR D. LITTLE, INC.
ACORN PARK
CAMBRIDGE, MA 02140

DECEMBER 1981

FINAL REPORT

prepared for

U.S. ARMY MOBILITY EQUIPMENT RESEARCH
AND DEVELOPMENT COMMAND
FORT BELVOIR, VIRGINIA 22060

CONTRACT NO.
DAAK70-79-D-0036

TASK ORDER NO. 0021

Copy available to DTIC does not
permit fully legible reproduction /

DTIC FILE COPY

This document has been approved
for public release; its
distribution is unlimited.

DTIC
ELECTRONIC
JUN 04 1982
S
E

Arthur D. Little, Inc.

DISCLAIMER NOTICE

THIS DOCUMENT IS BEST QUALITY PRACTICABLE. THE COPY FURNISHED TO DTIC CONTAINED A SIGNIFICANT NUMBER OF PAGES WHICH DO NOT REPRODUCE LEGIBLY.

DESIGN STUDY FOR MOUNTING THE CLASS 30
MEDIUM ARMORED VEHICLE LAUNCHED BRIDGE
AND LAUNCH MECHANISM ON A SUITABLE TRAILER

FINAL REPORT

Contract No. DAAK70-79-D-0036
Task Order No. 0021

Prepared for

U.S. Army Mobility Equipment
Research and Development Command
Fort Belvoir, Virginia 22060

by

Arthur D. Little, Inc.
Cambridge, MA 02140

86618-01

December 1981



Accession For	
NTIS GRA&I	<input checked="" type="checkbox"/>
DTIC TAB	<input type="checkbox"/>
Unannounced	<input type="checkbox"/>
Justification	<i>Dr on file</i>
By	
Distribution/	
Availability Codes	
and/or	
Dist	
Final	
<i>A</i>	<i>CP</i>

The views, opinions, and/or findings contained in this report are those of the authors and should not be construed as an official Department of the Army position, policy, or decision, unless so designated by other documentation.

UNCLASSIFIED

SECURITY CLASSIFICATION OF THIS PAGE (When Data Entered)

REPORT DOCUMENTATION PAGE		READ INSTRUCTIONS BEFORE COMPLETING FORM
1. REPORT NUMBER	2. GOVT ACCESSION NO. AD-A115131	3. RECIPIENT'S CATALOG NUMBER
4. TITLE (and Subtitle) Design Study for Mounting the Class 30 Medium Armored Vehicle Launched Bridge and Launch Mechanism on a Suitable Trailer		5. TYPE OF REPORT & PERIOD COVERED Final Report 6/81 - 12/81
		6. PERFORMING ORG. REPORT NUMBER 86618-01
7. AUTHOR(s) William P. Hidden		8. CONTRACT OR GRANT NUMBER(s) DAAK70-79-D-0036 Task Order 0021
9. PERFORMING ORGANIZATION NAME AND ADDRESS Arthur D. Little, Inc. Acorn Park Cambridge, MA 02140		10. PROGRAM ELEMENT, PROJECT, TASK AREA & WORK UNIT NUMBERS
11. CONTROLLING OFFICE NAME AND ADDRESS US Army Mobility Equipment Research and Development Command (MERADCOM) Fort Belvoir, VA 22060		12. REPORT DATE December 1981
		13. NUMBER OF PAGES 183
14. MONITORING AGENCY NAME & ADDRESS (if different from Controlling Office) N/A		15. SECURITY CLASS. (of this report) UNCLASSIFIED
		15a. DECLASSIFICATION/DOWNGRADING SCHEDULE
16. DISTRIBUTION STATEMENT (of this Report) <div style="border: 1px solid black; padding: 5px; width: fit-content; margin: 0 auto;"> <p>This document has been approved for public release; its distribution is unlimited.</p> </div>		
17. DISTRIBUTION STATEMENT (of the abstract entered in Block 20, if different from Report)		
18. SUPPLEMENTARY NOTES		
19. KEY WORDS (Continue on reverse side if necessary and identify by block number) Trailer Mounted Light Assault Bridge Double-Scissors Bridge Scissors Bridge Flip-Launch Bridge Beam-Launch Bridge		
20. ABSTRACT (Continue on reverse side if necessary and identify by block number) Descriptions are provided for seven different preliminary system designs for Class 30 trailer-mounted and -launched assault bridges. Findings, conclusions, and recommendations are given regarding a comparison of the systems including technical, operational, and cost trade-offs. X		

SUMMARY

This report summarizes the work conducted under the study entitled "Design Study for Mounting the Class 30 Medium Armored Vehicle Launched Bridge and Launch Mechanism on a Suitable Trailer." The report includes the following material:

- o Descriptions (including drawings) of preliminary designs of the trailer-mounted and -launched Class 30 assault bridge, based on seven concepts.
- o Estimated cost to design and build two prototype systems.
- o Comparison of the seven preliminary designs, including technical, operational, and cost trade-offs.
- o Recommendation of the preferred concept with supporting rationale.

The study concluded that the preferred concept is a scissors bridge based on the existing bridge and launch mechanism design, but incorporating modifications that improve air and ground transport and functional characteristics. Also included is a mechanized system for narrowing the bridge to permit loading it into C-141 aircraft.

This concept was preferred by a small margin over a similar concept that narrows the bridge for air transport manually by means of detachable deck extensions. Also, the scissors-bridge and double-scissors bridge concepts are judged to meet the requirements of the Revised Draft Required Operational Capability for the Light Assault Bridge, TRADOC ACN 67203, dated 15 September 81, except for cross-country mobility characteristics. If cross-country mobility is of overriding importance, a double-scissors bridge design, which folds into a more compact package, would become the preferred concept. All versions of the trailer-mounted bridge appear inferior in cross-country mobility capability to typical military trailer-mounted equipment; however, the double-scissors bridge has significantly better cross-country mobility characteristics than the other concepts considered in this study.

PREFACE

This report is submitted to the U.S. Army Mobility Equipment Research and Development Command (MERADCOM), Fort Belvoir, Virginia 22060, by Arthur D. Little, Inc., 20 Acorn Park, Cambridge, Massachusetts 02140, and was prepared under Task Order No. 0021 of Contract No. DAAK-70-79-D-0036. This report was prepared under the guidance of Messrs. Gerald Wilber, Richard Helmke, and George Williams as the technical points of contact, and Mr. Kenneth Dean as the COTR. Questions of a technical nature should be directed to William P. Hidden, (617) 864-5770, the Technical Program Manager and principal investigator of the study. The Administrative Program Manager was Roger G. Long, and other investigators included Robert H. Bode, Thomas P. Howard, Richard S. Lindstrom, and Robert M. Lucas.

TABLE OF CONTENTS

	Page
Report Documentation Page	1
Summary	3
Preface	5
Table of Contents	7
List of Figures	11
List of Tables	13
1.0 INTRODUCTION AND SUMMARY	15
1.1 Background	15
1.2 Objective	16
1.3 Scope of Work	16
1.4 Findings	18
1.5 Conclusions	22
1.6 Recommendations	23
2.0 TASK I. SCISSORS BRIDGE, MINIMUM MODIFICATION	25
2.1 System Characteristics	25
2.2 Bridge	25
2.3 Launch Mechanism	28
2.4 Launch Sequence	28
2.5 Retrieval Sequence	30
3.0 TASK IIA. SCISSORS BRIDGE, MODIFIED	33
3.1 System Characteristics	33
3.2 Bridge	33
3.3 Launch Mechanism	34
3.4 Launch Sequence	34
3.5 Retrieval Sequence	36
4.0 TASK IIB. SCISSORS BRIDGE, MODIFIED	39
4.1 System Characteristics	39
4.2 Bridge	39
4.3 Launch Mechanism	41
4.4 Launch Sequence	41
4.5 Retrieval Sequence	43

TABLE OF CONTENTS (Continued)

	Page
5.0 TASK IIIA. FLIP-LAUNCH BRIDGE	47
5.1 System Characteristics	47
5.2 Bridge	47
5.3 Launch Mechanism	48
5.4 Launch Sequence	49
5.5 Retrieval Sequence	52
6.0 TASK IIIB. BEAM-LAUNCH BRIDGE	55
6.1 System Characteristics	55
6.2 Bridge	55
6.3 Launch Mechanism	56
6.4 Launch Sequence	57
6.5 Retrieval Sequence	59
7.0 TASK IIIC1. DOUBLE-SCISSORS BRIDGE	63
7.1 System Characteristics	63
7.2 Bridge	63
7.3 Launch Mechanism	64
7.4 Launch Sequence	65
7.5 Retrieval Sequence	66
8.0 TASK IIIC2. DOUBLE-SCISSORS BRIDGE	69
8.1 System Characteristics	69
8.2 Bridge	69
8.3 Launch Mechanism	70
8.4 Launch Sequence	70
8.5 Retrieval Sequence	72
9.0 TRAILER	75
9.1 Required Characteristics	75
9.2 Compliance with MIL-C-52437B(ME)	83
10.0 HYDRAULIC POWER SUPPLY	85

TABLE OF CONTENTS (Continued)

	Page
11.0 AIR TRANSPORT	87
11.1 Conformity with Requirements	87
11.2 Preparation for Loading	87
11.3 Loading Procedure	88
11.4 Off-Loading Procedure	97
11.5 Preparation for Ground Transport	97
12.0 COST ESTIMATES	99
12.1 Introduction	99
12.2 Methodology	99
13.0 COMPARISON OF SYSTEM CONCEPTS	109
13.1 Introduction	109
13.2 Trade-Off Analysis	141
14.0 COMPOSITE	155
14.1 Summary	155
14.2 Bridge	155
14.3 Launch Mechanism	159
14.4 Trailer	159
APPENDIX A – PRELIMINARY DESIGN DRAWINGS	161

LIST OF FIGURES

Figure No.		Page
1	Conceptual Design: Deck Extensions	27
2	Existing Trailer Design, 8-Wheel Suspension	78
3	Deflection Characteristics of 8-Wheel Suspension	79
4	Existing Trailer Design, 4-Wheel Suspension	80
5	Existing 4-Wheel Suspension Design	81
6	Task I Scissors Bridge: Rearward Loading Into C-141 Aircraft	90
7	Task IIA Scissors Bridge: Rearward Loading Into C-141 Aircraft	91
8	Task IIB Scissors Bridge: Rearward Loading Into C-141 Aircraft	92
9	Task IIIA Flip-Launch Bridge: Rearward Loading Into C-141 Aircraft	93
10	Task IIIB Beam-Launch Bridge: Rearward Loading Into C-141 Aircraft	94
11	Task IIIC1 Double-Scissors Bridge: Rearward Loading Into C-141 Aircraft	95
12	Task IIIC2 Double-Scissors Bridge: Rearward Loading Into C-141 Aircraft	96
13	Task I Scissors Bridge, Air and Ground Transport Configurations	115
14	Task IIA Scissors Bridge, Air and Ground Transport Configurations	116
15	Task IIB Scissors Bridge, Air and Ground Transport Configurations	117
16	Task IIIA Flip-Launch Bridge, Air and Ground Transport Configurations	118
17	Task IIIB Beam-Launch Bridge, Air and Ground Transport Configurations	119
18	Task IIIC1 Double-Scissors Bridge, Air and Ground Transport Configurations	120
19	Task IIIC2 Double-Scissors Bridge, Air and Ground Transport Configurations	121
20	Concept of Composite Bottom Chord	156

LIST OF TABLES

Table No.		Page
1	Salient Characteristics of System Concepts	19
2	Summary of Estimated Costs	20
3	Summary of Concept Comparison Trade-Offs	21
4	Estimated Cost, Task I Scissors Bridge	100
5	Estimated Cost, Task IIA Scissors Bridge	101
6	Estimated Cost, Task IIB Scissors Bridge	102
7	Estimated Cost, Task IIIA Flip-Launch Bridge	103
8	Estimated Cost, Task IIIB Beam-Launch Bridge	104
9	Estimated Cost, Task IIIC1 Double-Scissors Bridge	105
10	Estimated Cost, Task IIIC2 Double-Scissors Bridge	106
11	Bridge, General Characteristics	110
12	Bridge, Physical Characteristics	112
13	System, Logistical Characteristics, Air Transport	122
14	Estimated Weights	123
15	System, Logistical Characteristics, Ground Transport	127
16	System, Operational Characteristics, Launch	131
17	Control Functions	133
18	System, Operational Characteristics, Retrieval	138
19	System, RAM Characteristics	139
20	System, General Characteristics	142

1.0 INTRODUCTION AND SUMMARY

This report summarizes the results of a design study in which seven concepts for a Class 30 trailer-mounted and -launched assault bridge were investigated and compared. These concepts included three scissors-type bridges, a flip-launch bridge, a beam-launch bridge, and two double-scissors-type bridges. The comparison included technical, operational, and cost trade-offs.

1.1 Background

Both the Army and the Marine Corps urgently need an air-transportable lightweight bridging system to support light infantry in rapid deployment force operations. The revised draft Required Operation Capability for the Light Assault Bridge, 15 September 1981, cites the following operational deficiency:

Sophisticated Threat target acquisition capability, weapons accuracy, and weapon response time dictate, that during the 1980's time frame, friendly forces will require the mobility to rapidly maneuver on the battlefield, maintain dispersion and quickly mass to concentrate fires. These maneuvers must take place with no time delays being caused by gap obstacles covered by fire. The Army does not have the capability for light forces to cross gaps in stride under fire. Because of the worldwide threat, the U.S. Army has the requirement to rapidly deploy light forces quickly. The Armored Vehicle Launched Bridge (AVLB), which is mounted on a M60 or M48 tank chassis, is the current Army standard assault bridge. It is too heavy and too large for strategic airlift in the designated C-141 aircraft and is not compatible with light force operations. Lightweight bridges which are currently

available (M4T6 dry span, M2 Bailey and Medium Girder Bridge) are manpower-intensive and slow to construct, making them inappropriate for an assault operation.

In 1971, an Army-designed Class 30 medium armored vehicle launched bridge with a 60-foot span was built and tested in prototype form. Although the project was terminated before publication of a report, the testing is considered to have been generally successful. This system, which comprised a scissors bridge and hydraulically actuated launch mechanism utilizing an overhead cantilever launch technique, provided the starting point for this study, in which trailer-mounted and -launched versions of the existing design are compared to other concepts.

1.2 Objective

The objective of this task order was to determine the configuration and development cost for a lightweight, light load class, high-mobility assault bridge for the Light Division.

1.3 Scope of Work

The scope of this study included the following tasks:

- o Task I. Prepare a preliminary design representing the minimum modification required to adapt the existing Army design of a Class 30 medium armored vehicle launched bridge for mounting on a suitable trailer.

- o Task II. Investigate modifications to the Task I bridge and launch system to reduce mass and bulk and to improve system mobility and function. Under this task, two preliminary designs were prepared:
 - Task IIA. A scissors-bridge system modified to improve air and ground transport characteristics and eliminate hydraulics from the bridge.

- Task IIB. Further modification of a scissors-bridge system to provide mechanized narrowing for air transport.

- o Task III. Prepare preliminary designs based on a flip-launch bridge concept, suggested by the U.S. Army Mobility Equipment Research and Development Command (MERADCOM), and a contractor-selected concept. The contractor originally selected a beam-launch bridge concept utilizing a telescoping traverse beam which is part of the trailer frame. When it became apparent that all concepts under consideration had poor cross-country mobility characteristics, a double-scissors bridge concept was also included. This concept utilizes the same launch mechanism as the Task II concepts, but folds into a shorter package, therefore having better cross-country mobility characteristics than any of the other concepts. MERADCOM has also built and tested a prototype bridge of this type.

Therefore, Task III included preparation of the following preliminary designs:

- Task IIIA. Flip-launch bridge system.
- Task IIIB. Beam-launch bridge system.
- Task IIIC1. Double-scissors bridge system.
- Task IIIC2. Double-scissors bridge system modified to provide mechanized narrowing for air transport.

Also included in the scope of work were:

- o Preparation of an estimated cost to design and build two prototype systems for each of the concepts under consideration.

- o Comparison of all concepts, including technical, operational, and cost trade-offs, and a recommendation for the preferred concept.

Table 1 summarizes the salient characteristics of the seven system concepts. Complete descriptions of the concepts appear in Chapters 2 through 8. The preliminary design layout drawings are included in Appendix A.

During the study, considerable effort was expended in determining how to meet the requirement of air transportability in C-130 aircraft, as originally required by the draft Required Operation Capability (ROC). When the study was in progress for approximately two months, this requirement was eliminated, and the C-141 was designated as the only aircraft to be used. This change had an important impact on the problems involved in narrowing the bridge for air transport, since the maximum cargo widths permitted for loading are 99 inches in the C-130 aircraft and 111 inches in the C-141 aircraft.

1.4 Findings

1.4.1 Cost Estimates

Table 2 summarizes the estimated costs to design and build two prototype systems for each concept. Detailed cost estimates are provided in Tables 4 through 10 in Chapter 12.

1.4.2 Comparison of Concepts

Table 3 summarizes the comparison of the seven concepts, including technical, operational, and cost trade-offs. A detailed listing of the trade-offs and a discussion of the supporting rationale are provided in Chapter 13.

TABLE 1. SALIENT CHARACTERISTICS OF SYSTEM CONCEPTS

	<u>Task I</u>	<u>Task IIA</u>	<u>Task IIB</u>	<u>Task IIIA</u>	<u>Task IIIB</u>	<u>Task IIIC1</u>	<u>Task IIIC2</u>
System Concept	Scissors Bridge Minimum Modification	Scissors Bridge Modified	Scissors Bridge Modified	Flip-Launch Bridge	Beam-Launch Bridge	Double-Scissors Bridge	Double-Scissors Bridge
Bridge Span	60 ft	60 ft	60 ft	23 m	23 m	60 ft	60 ft
Bridge Folding	Single Fold Downward	Single Fold Downward	Single Fold Downward	Double Fold Upward	Double Fold Upward	Double Fold Downward	Double Fold Downward
Method of Narrowing for Air Transport	Manually Detachable Deck Extensions	Manually Detachable Deck Extensions	Folding Cross-Bracing Mechanized Narrowing	Manually Detachable Deck Extensions	Manually Detachable Deck Extensions	Manually Detachable Deck Extensions	Folding Cross-Bracing Mechanized Narrowing
Launch Method	Overhead Cantilever	Overhead Cantilever	Overhead Cantilever	Cantilever	Traverse Beam in Trailer	Overhead Cantilever	Overhead Cantilever

TABLE 2. SUMMARY OF ESTIMATED COSTS
(Dollars)

	Development Cost ^a	Construction Cost 2 Systems	Total Cost 2 Systems
Task I. Scissors Bridge	235,000	445,000	680,000
Task IIA. Scissors Bridge	285,000	455,000	740,000
Task IIB. Scissors Bridge	330,000	470,000	800,000
Task IIIA. Flip-Launch Bridge	520,000	615,000	1,135,000
Task IIIB. Beam-Launch Bridge	620,000	630,000	1,250,000
Task IIIIC1. Double-Scissors Bridge	335,000	500,000	835,000
Task IIIIC2. Double-Scissors Bridge	395,000	535,000	930,000

^aTo be used only for relative comparisons between bridge systems.

TABLE 3. SUMMARY OF CONCEPT COMPARISON TRADE-OFFS

System Concept	Task I Scissors Bridge Minimum Modification	Task IIA Scissors Bridge Modified	Task IIB Scissors Bridge Modified	Task IIA Flip-Launch Bridge	Task IIR Beam-Launch Bridge	Task IIIC1 Double-Scissors Bridge	Task IIIC2 Double-Scissors Bridge
Overall Dimensions Air Transport	38 ft, 4 in. Long 110 in. Wide 92 in. High 84 in. Rear Height	38 ft, 0 in. Long 110 in. Wide 92 in. High 78 in. Rear Height	38 ft, 0 in. Long 110 in. Wide 96 in. High 78 in. Rear Height	42 ft, 6 in. Long 110 in. Wide 88 in. High 88 in. Rear Height	42 ft, 3 in. Long 110 in. Wide 88 in. High 88 in. Rear Height	30 ft, 9 in. Long 110 in. Wide 90 in. High 86 in. Rear Height	30 ft, 9 in. Long 110 in. Wide 94 in. High 90 in. Rear Height
Overall Dimensions Ground Transport	38 ft, 4 in. Long 130 in. Wide 132 in. High	38 ft, 0 in. Long 110 in. Wide 102 in. High	38 ft, 0 in. Long 110 in. Wide 102 in. High	42 ft, 6 in. Long 130 in. Wide 94 in. High	42 ft, 3 in. Long 130 in. Wide 94 in. High	30 ft, 9 in. Long 130 in. Wide 100 in. High	30 ft, 9 in. Long 110 in. Wide 100 in. High
Overall Weight	19,900 lb ^a 17,700 lb ^b 2	20,100 lb ^a 17,400 lb ^b 1	20,600 lb ^a 18,600 lb ^b 1	23,900 lb ^a 3	24,700 lb ^a 3	19,900 lb ^b 2	20,600 lb ^b 2
Air Transport Loading Difficulty ^c	2	2	1	3	3	2	2
Ground Transport Preparation ^c	2	2	1	3	3	2	1
Cross-Country Mobility ^c	3	2	2	4	4	1	1
Launch & Retrieval Characteristics ^c	1	1	1	3	3	2	2
RAM Characteristics ^c	1	1	1	2	2	1	1
Estimated Cost for Prototypes	\$680,000	\$740,000	\$800,000	\$1,135,000	\$1,250,000	\$835,000	\$930,000
Development Risk	Very Low	Low	Low	High	Very High	Low	Low

^aWeight with 8-wheel, 12 x 16.5 tire suspension.

^bWeight with 4-wheel, 14 x 17.5 tire suspension.

^cNumerical ratings are comparative; lower numbers indicate better ratings.

1.5 Conclusions

1.5.1 Task IIIA Concept (Flip-Launch Bridge) and Task IIIB Concept (Beam-Launch Bridge)

These concepts compare less favorably with all other concepts in most of the important criteria. Their only superior characteristic is their longer span. Should a span longer than 60 feet become a required or desired configuration, the double-scissors concepts offer the better basis for designing a longer bridge.

1.5.2 Task I Concept (Scissors Bridge with Minimum Modification of Existing Army Design)

The modifications necessary to improve the aircraft loading and cross-country mobility characteristics of this concept and to remove the hydraulics from the bridge (i.e., the changes embodied in the Task IIA concept) are relatively low in additional cost and development risk. The Task I concept should therefore be eliminated from consideration.

1.5.3 Task IIA and IIB Scissors-Bridge Concepts vs Task IIIC1 and IIIC2 Double-Scissors Bridge Concepts

The single-scissors bridge concepts have advantages over the double-scissors bridge concepts in aircraft loading, launch and retrieval characteristics, RAM characteristics, and cost. The Task IIA and IIB concepts are therefore preferred over the Task IIIC1 and IIIC2 concepts. However, if cross-country mobility becomes an overriding consideration, then the double-scissors bridge concepts would be preferred because of their significantly better (although still only fair) mobility characteristics. All four concepts are capable of satisfying all important requirements of the draft ROC except for cross-country mobility.

1.5.4 Task IIA Scissors Bridge vs Task IIB Scissors Bridge

The manually detachable deck extensions of the Task IIA concept and the folding cross-bracing of the Task IIB concept are considered to be approximately equal in degree of complexity. The mechanized narrowing of the

Task IIB concept offers advantages in that it provides ease of preparation for ground transport after unloading from the aircraft, and in its ability to be towed to the launch site in the narrow width if desired. The Task IIB concept is therefore the preferred system, although the choice over the Task IIA concept is close.

1.6 Recommendations

Based on the above conclusions, we recommend that the Task IIB concept, scissors bridge with folding cross-bracing and mechanized narrowing, be the basis for design of the prototype trailer-mounted assault bridge systems. However, we also recommend that scale models of the Task I, Task IIA and IIB, and Task IIIC1 and IIIC2 concepts be built and studied at the earliest possible date. This will provide greater insight into the relative merits of the concepts and will identify potential development problems at an early stage.

2.0 TASK I. SCISSORS BRIDGE, MINIMUM MODIFICATION

2.1 System Characteristics

This system concept is illustrated in preliminary design form in Appendix A, Drawing E-4193-007, Sheet 1. It represents the minimum modification required to adapt the existing Army design of a Class 30 assault-bridge and tank-chassis-mounted launch mechanism to a trailer-mounted and -launched configuration. The bridge is a single-fold scissors-type with geared hinges in the bottom chords and a folding mechanism actuated by a hydraulic cylinder mounted on the bridge. The bridge is launched by the overhead cantilever method, using a fully automatic remote-controlled mechanism actuated by hydraulic cylinders powered by a diesel-engine-driven supply unit mounted on the trailer.

2.2 Bridge

The dimensions of this bridge are as follows:

Span: 60 ft

Overall Length: 62 ft, 6 in.

Roadway Width: 126 in.

Overall Width (including curbs): 130 in.

Air Transport Width: 110 in.

Ground Transport Width: 130 in.

The bridge is identical to the existing Army design defined by MERADCOM Drawings D13219E1071 through D13219E1087, except for the following changes:

- o Modification of the extruded aluminum bottom chords to compensate for the lower tensile strength of 7005-T53 aluminum as compared to the 7039-T53 aluminum specified in the drawings. This change is necessary since 7039 aluminum is no longer used in Army bridges because of stress

corrosion problems. The thickness of the bottom chords was increased from 0.44 to 0.47 in.

- o Addition of deck extensions to the outer edges of the treadways; detachable to narrow the bridge to 110 in. for loading in the C-141 aircraft. These extensions are in 4 ft lengths and are manually attached to the bridge after it is unloaded from the aircraft by means of slidable-engaging, interlocking, extruded aluminum channels welded to the edges of the deck and the extensions. The extensions have upstanding curbs to prevent vehicles from sliding off the bridge. These curbs are attached to the extensions by fasteners that are designed to fail under overload conditions without damaging the deck extensions. The deck extensions are stowed in a compartment on the trailer frame under the bridge during air transport. Figure 1 presents a conceptual design for these deck extensions.

- o Repositioning of the outer girders to achieve the 110 in. air transport width.

Construction materials are:

Deck: 7005-T53 aluminum extrusion (existing design)

Bottom chords: 7005-T53 aluminum extrusion (slightly modified existing design)

Girder webs: 6061-T6 aluminum sheet

Attachments, etc.: 6061-T6 aluminum plate and sheet

Cross-bracing: 7005-T53 aluminum extrusions and 6061-T6 aluminum plate

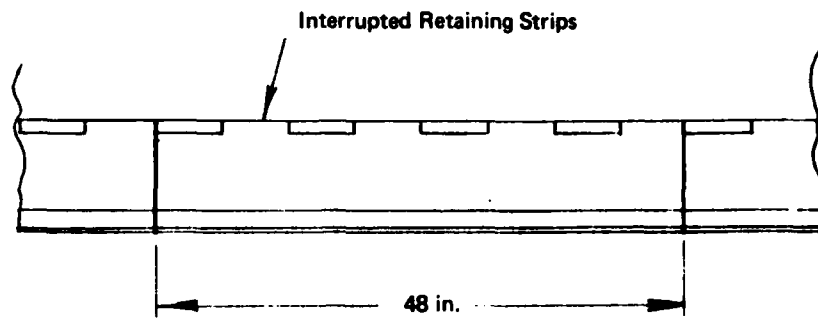

Section Length

Plan View, Scale: $\frac{3}{4}''=1'$

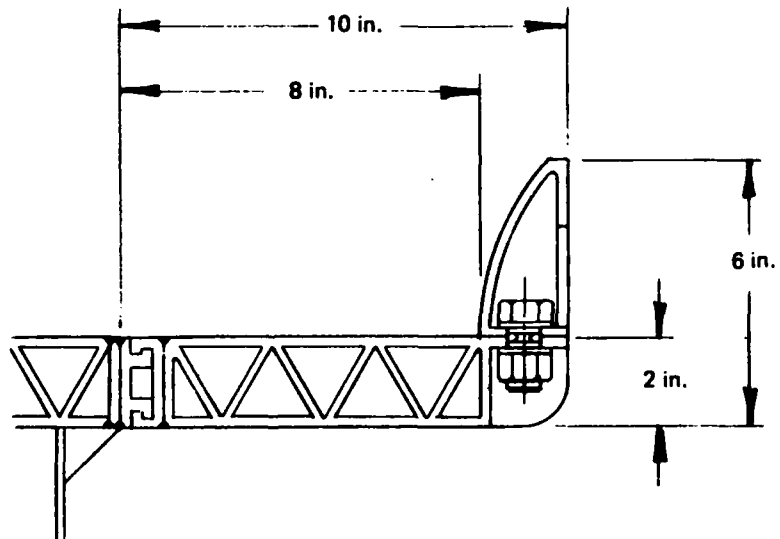

Sectional View, Scale: $\frac{1}{4}$ Size

FIGURE 1 CONCEPTUAL DESIGN: DECK EXTENSIONS

Folding linkage and pick-up sockets: T-1 steel

Hinges and pins: 4340 steel

Curbs: 7005-T53 aluminum extrusion (new design)

2.3 Launch Mechanism

With one exception, the launch mechanism is identical to the existing Army design defined by the unnumbered preliminary drawings which accompanied the Statement of Work for this Task Order. The pivot point for the launch boom was moved to a lower position to adapt to the trailer mounting and to keep the height of the bridge in the stowed position at the rear of the trailer from exceeding the limit for loading in the C-141 aircraft. This change made it necessary to relocate the boom actuating cylinders and their mounting points. No change was made in the operation of the launch mechanism, however.

2.4 Launch Sequence (Appendix A, Drawing E-4193-007, Sheet 2)

1. Position trailer. This step is accomplished while communicating with observing personnel in an accompanying vehicle.
2. Start power supply engine. This step is done from inside the tow vehicle by using the glow plug switch and starter push button on the remote control panel. It can be done while the trailer is being moved into position.
3. Deploy outriggers. Hydraulic cylinders rotate the outriggers to a vertical position. The cylinders are controlled by a solenoid valve actuated from inside the tow vehicle by 3-position (extend-off-retract) push buttons on the remote control panel. (All of the following launch functions are controlled in the same way.) Estimated time is 15 seconds.

4. Lower outriggers to level the trailer laterally. The outriggers are controlled separately. Estimated time is 30 seconds.
5. Raise bridge. The launch boom is rotated approximately 90 degrees by extending its actuating cylinders, raising the bridge to an approximately vertical position. Estimated time is 30 seconds.
6. Unfold and lower bridge on far bank. These operations are performed simultaneously by extending the launch tongue cylinders to lower the bridge and retracting the folding cylinder to unfold the bridge. The operator must coordinate the two operations so that the bridge is fully unfolded before it lands on the far bank. Estimated time is 90 seconds.
7. Retract lock pins. Hydraulic cylinders retract the lock pins, disengaging them from the pick-up sockets in the toes of the bridge ramps. Estimated time is 5 seconds.
8. Lower bridge on near bank. The tongue cylinders are extended as required to set the bridge down on the near bank. On a bank with lateral slope, adjusting the outriggers may be necessary to lower the bridge to an equilibrium position. Estimated time is 10 seconds.
9. Raise and stow outriggers. Estimated time 15 seconds.
10. Disengage launch mechanism from bridge. The trailer is towed forward to withdraw the tongue cross-pin from the pick-up slots in the bridge and break the hydraulic connections. This can be done before the outriggers are fully stowed. Estimated time is 15 seconds.

11. Stow launch mechanism. Boom and tongue actuating cylinders are retracted. This can be done while driving away. Estimated time is 80 seconds.
12. Shut off power unit engine and drive away. Estimated total launch time is 3.5 minutes.

2.5 Retrieval Sequence

1. Position trailer. This step requires communicating with personnel on the ground or in an accompanying vehicle.
2. Start power unit engine.
3. Extend boom and tongue actuating cylinders. Estimated time is 80 seconds.
4. Engage launch mechanism with bridge. This step is done by lowering the tongue and backing up the trailer until the cross-pin of the tongue is seated in the pick-up slots of the bridge and the hydraulic connections are engaged. Direct supervision by the operator is required. Estimated time is 60 seconds.
5. Deploy and lower outriggers. Estimated time is 30 seconds.
6. Raise bridge off near bank. The tongue actuating cylinders are partially retracted, lifting the bridge until the lock pins are aligned with the pick-up sockets in the toes of the bridge ramps. Estimated time is 20 seconds.
7. Engage lock pins. Estimated time is 5 seconds.
8. Raise and fold bridge. The tongue actuating cylinders are retracted to lift the bridge off the far bank. The folding cylinder is then allowed to extend against pressure to control the folding mechanism as the weight of the ramp

folds the bridge. Simultaneously, the tongue cylinders are retracted, lifting the bridge to a vertical position. Estimated time is 90 seconds.

9. Lower bridge onto trailer. The boom actuating cylinders are retracted to rotate the boom and lower the bridge. Estimated time is 30 seconds.
10. Raise and slow outriggers. Estimated time is 15 second.
11. Shut off power unit engine and drive away. Estimated total retrieval time is 5.5 minutes.

3.0 TASK IIA. SCISSORS BRIDGE, MODIFIED

3.1 System Characteristics

This system concept is illustrated in preliminary drawing form in Appendix A, Drawing E-4193-008. It is similar to the Task I system, but incorporates the following improvements:

- o Removal of the folding cylinder from the bridge, eliminating the need for hydraulic connections to the bridge (a potential source of trouble) and removing the vulnerable hydraulic cylinder and lines from the bridge.
- o Lowering of the near end of the bridge by 6 in. when stowed on the trailer, easing the aircraft loading operation.

3.2 Bridge

Dimensions of this bridge are the same as the Task I system as follows:

Span: 60 ft .
Overall Length: 62 ft, 6 in.
Roadway Width: 126 in.
Overall Width (including curbs): 130 in.
Air Transport Width: 110 in.
Ground Transport Width: 130 in.

The bridge is identical to the Task I preliminary design except that the folding mechanism was changed to provide for actuation by a hydraulic cylinder mounted on the launch mechanism rather than on the bridge. The folding mechanism is a linkage similar in principle to the folding linkage in the Army design. It is of symmetrical design and is actuated by tubular tension members from either side of the bridge. The tension members are

connected to sliding frames, one frame in each half of the bridge. Sockets in the sliding frames are engaged by a cross-pin on the piston rod of the actuating cylinder mounted on the launch mechanism tongue.

3.3 Launch Mechanism

The launch mechanism for this concept is similar to the Task I preliminary design except for the following changes:

- o The actuating cylinders for the boom and tongue are located between, rather than in line with, the longitudinal members of the boom and tongue. This alinement permits the launch mechanism members to nest more compactly in stowed position on the trailer, reducing the height of the rear end of the bridge.
- o A hydraulic cylinder was mounted longitudinally in the center of the tongue to actuate the modified folding system of the bridge.

3.4 Launch Sequence (Appendix A, Drawing E-4193-007, Sheet 2)

1. Position trailer. This step is accomplished while communicating with observing personnel in an accompanying vehicle.
2. Start power supply engine. This step is done from inside the tow vehicle by using the glow plug switch and starter push button on the remote control panel. It can be done while the trailer is being moved into position.
3. Deploy outriggers. Hydraulic cylinders rotate the outriggers to a vertical position. The cylinders are controlled by a solenoid valve actuated from inside the tow vehicle by 3-position (extend-off-retract) push buttons on the remote control panel. (All of the following

launch functions are controlled in the same way.)
Estimated time is 15 seconds.

4. Lower outriggers to level the trailer laterally. The outriggers are controlled separately. Estimated time is 30 seconds.
5. Raise bridge. The launch boom is rotated approximately 90 degrees by extending its actuating cylinders, raising the bridge to an approximately vertical position. Estimated time is 30 seconds.
6. Unfold and lower bridge onto far bank. These operations are performed simultaneously by extending the launch tongue cylinders to lower the bridge and retracting the folding cylinder to unfold the bridge. The operator must coordinate the two operations so that the bridge is fully unfolded before it lands on the far bank. Estimated time is 90 seconds.
7. Retract lock pins. Hydraulic cylinders retract the lock pins, disengaging them from the pick-up sockets in the toes of the bridge ramps. Estimated time is 5 seconds.
8. Lower bridge onto near bank. The tongue cylinders are extended as required to set the bridge down on the near bank. The folding cylinder is pivotally mounted on the tongue, so that the cylinder remains in alignment with the bridge as the tongue rotates with respect to the bridge during the lowering motion. On a bank with lateral slope, adjusting the outriggers may be necessary to lower the bridge to an equilibrium position. Estimated time is 10 seconds.
9. Raise and stow outriggers. Estimated time is 15 seconds.

10. Disengage tongue cross-pin from bridge. The trailer is towed forward approximately 8 in. to withdraw the tongue cross-pin from the pick-up slots in the bridge. This can be done before the outriggers are completely stowed. During this operation, the piston rod of the folding cylinder is allowed to extend 8 in., since the piston rod end is still connected to the bridge folding mechanism. Estimated time is 15 seconds.
11. Disengage folding cylinder piston rod from bridge and stow launch mechanism. The tongue actuating cylinder is retracted to lift the folding cylinder piston rod end out of engagement with the bridge folding mechanism. The boom and tongue actuating cylinders are then retracted simultaneously to stow the launch mechanism. Estimated time is 80 seconds.
12. Shut off power unit engine and drive away. Estimated total launch time is 3.5 minutes.

3.5 Retrieval Sequence

1. Position trailer. This step requires communicating with personnel on the ground or in an accompanying vehicle.
2. Start power unit engine.
3. Extend boom and tongue actuating cylinders. Estimated time is 80 seconds.
4. Extend folding cylinder. This step is done only if the bridge is being picked up at the opposite end from which it was launched. Estimated time is 30 seconds.
5. Engage launch mechanism with bridge. The tongue is lowered until the piston rod end of the folding cylinder is seated

in the slot of the sliding frame of the bridge folding mechanism. The tongue is then lowered farther until the cross-pin rests on the pick-up slots, and the trailer is backed until the cross-pin is seated in the pick-up slots. This will require supervision by an operator on the ground. Estimated time is 60 seconds.

6. Deploy and lower outriggers. Estimated time is 30 seconds.
7. Raise bridge off near bank. The tongue actuating cylinders are partially retracted, lifting the bridge until the lock pins are alined with the pick-up sockets in the toes of the bridge ramps. Estimated time is 20 seconds.
8. Engage lock pins. Estimated time is 5 seconds.
9. Retract folding cylinder. This step is done only if the bridge is being picked up at the opposite end from which it was launched. Estimated time is 20 seconds.
10. Raise and fold bridge. The tongue actuating cylinders are retracted to lift the bridge off the far bank. The folding cylinder is then allowed to extend against pressure to control the folding mechanism as the weight of the ramp folds the bridge. Simultaneously, the tongue cylinders are retracted, lifting the bridge to a vertical position. Estimated time is 90 seconds.
11. Lower bridge onto trailer. The boom actuating cylinders are retracted to rotate the boom and lower the bridge. Estimated time is 30 seconds.
12. Raise and stow outriggers. Estimated time is 15 seconds.

13. Shut off power unit engine and drive away. Estimated total retrieval time is as follows:

- o From launch end: 5.5 minutes.
- o From opposite end: 6.4 minutes.

4.0 TASK IIB. SCISSORS BRIDGE, MODIFIED

4.1 System Characteristics

This system concept is illustrated in preliminary design form in Appendix A, Drawing E-4193-009. It is similar to the Task IIA system. The only difference is that the required narrowing of the bridge for loading in the C-141 aircraft is accomplished by moving the treadways closer together rather than by removable deck extensions. The narrowing and widening operations are performed by the launch mechanism. The bridge is widened in two ways: under power after unloading from the aircraft, or if desired, the bridge can be towed to the launch site in the narrow configuration and widened under power by remote control just before launch.

4.2 Bridge

The dimensions of this bridge are as follows:

Span: 60 ft

Overall Length: 62 ft, 6 in.

Roadway Width: 126 in.

Overall Width (including curbs): 130 in.

Air Transport Width: 110 in.

Ground Transport Width: 110 or 130 in.

The bridge is similar to the Task IA preliminary design except for the following changes:

- o The decks do not have detachable edge extensions. Each treadway has a 1-piece, 45 in. wide deck like the existing Army design. Upstanding curbs identical to those used in the Task I and Task IIA designs are attached to the outer edges of the decks by means of fasteners designed to fail under overload conditions without damaging the deck.

- o The vertical braces were modified by adding hinges to permit the braces to fold as the bridge is narrowed for air transport. The vertical braces of each half of the bridge are connected by a longitudinal rod. When the bridge is widened and unfolded, the ends of the rods in the two halves of the bridge butt each other, locking the braces in the straight position. The braces are lightly spring-loaded, by torsion springs in the pivots, toward the folded position to break the toggle effect at the beginning of the bridge-narrowing operation.

- o The mountings at one end of the longitudinal braces were provided with elongated slots to permit the braces to collapse as the bridge is narrowed. When the bridge is widened, the pins in the ends of the braces seat against the ends of the slots, and the braces function as tension members.

- o The folding mechanism of the Task IIA concept was modified to permit the bridge to be narrowed. Two folding linkages are mounted on the sides of the girders between the treadways and are actuated by tubular tension members from either side of the bridge. The tension members are connected to sliding frames, one frame in each half of the bridge. These frames slide in elongated slots in the inside wall of each girder, and telescope through the girders when the bridge is narrowed for transport. The area around the slots in the girders must be reinforced to provide a section modulus equivalent to that of the present design. Sockets in the sliding frames are engaged by a cross-pin on the piston rod of the actuating cylinder mounted on the launch mechanism tongue.

4.3 Launch Mechanism

The launch mechanism is the same as the Task IIA preliminary design except that a bridge-narrowing and -widening mechanism was added. Two tubular cross-members were added to the tongue, each containing two cylindrical slides on which are mounted the pick-up pins that engage the four pick-up sockets in the bridge. These slides can be driven inward or outward by two lead screws driven through a connecting shaft and gear-boxes by a hydraulic motor. This narrows the bridge for air transport or widens it for deployment while the pick-up pins remain engaged in the pick-up sockets. The lead screws are protected from dust and dirt by flexible accordian-type boots.

4.4 Launch Sequence (Appendix A, Drawing E-4193-007, Sheet 2)

1. Position trailer. This step is accomplished while communicating with observing personnel in an accompanying vehicle.
2. Start power supply engine. This step is done from inside the tow vehicle by using the glow plug switch and starter push button on the remote control panel. It can be done while the trailer is being moved into position.
3. Deploy outriggers. Hydraulic cylinders rotate the outriggers to a vertical position. The cylinders are controlled by a solenoid valve actuated from inside the tow vehicle by 3-position (extend-off-retract) push buttons on the remote control panel. (All of the following launch functions are controlled in the same way.) Estimated time is 15 seconds.
4. Lower outriggers to level the trailer laterally. The outriggers are controlled separately. Estimated time is 30 seconds.
5. Widen bridge to 130 in. If desired, this step can be done before reaching the launch site. The boom cylinders are

actuated to lift the bridge slightly off the supports. The hydraulic motor is then operated to rotate the lead screws and drive the bridge to its full width. During the widening operation, parallelism of the two sides of the bridge is maintained by the vertical braces, which are interconnected by rods as previously described. Estimated time is 30 seconds.

6. Raise bridge. The launch boom is rotated approximately 90 degrees by extending its actuating cylinders, raising the bridge to an approximately vertical position. Estimated time is 30 seconds.
7. Unfold and lower bridge on far bank. These operations are performed simultaneously by extending the launch tongue cylinders to lower the bridge and retracting the folding cylinder to unfold the bridge. The operator must coordinate the two operations so that the bridge is fully unfolded before it lands on the far bank. Estimated time is 90 seconds.
8. Withdraw pick-up pins from sockets in toes of bridge ramp. The hydraulic motor is actuated, causing the lead screws to move the pick-up slides inward. In this position, the inboard pick-up pins have been withdrawn from the sockets in the ramp toes, but the outboard pick-up pins remain engaged with the pick-up slots on the sides of the bridge girders. The near end of the bridge is thus still supported by the outboard pick-up pins. Estimated time is 15 seconds.
9. Lower bridge on near bank. The tongue cylinders are extended as required to set the bridge down on the near bank. The folding cylinder is pivotally mounted on the tongue, so that the cylinder remains in alignment with the bridge as the tongue rotates with respect to the bridge during the lowering motion. On a bank with lateral slope,

adjusting the outriggers may be necessary to lower the bridge to an equilibrium position. Estimated time is 10 seconds.

10. Raise and stow outriggers. Estimated time is 15 seconds.
11. Disengage outboard pick-up pins from bridge. The trailer is towed forward to withdraw the outboard pick-up pins from pick-up slots in the bridge. This step can be done before the outriggers are completely stowed. Estimated time is 15 seconds.
12. Disengage folding cylinder piston rod from bridge and stow launch mechanism. The tongue actuating cylinder is retracted to lift the folding cylinder piston rod end out of engagement with the bridge folding mechanism. The boom and tongue actuating cylinders are then retracted simultaneously to stow the launch mechanism. Estimated time is 80 seconds.
13. Shut off power unit engine and drive away. Estimated total launch time is as follows:
 - o 3.7 minutes if bridge is widened before reaching launch site.
 - o 4.2 minutes if bridge is widened at launch site.

4.5 Retrieval Sequence

1. Position trailer. This step requires communicating with personnel on the ground or in an accompanying vehicle.
2. Start power unit engine.
3. Extend boom and tongue actuating cylinders. Estimated time is 80 seconds.

4. Extend folding cylinder. This step is done only if the bridge is being picked up at the opposite end from which it was launched. Estimated time is 30 seconds.
5. Engage launch mechanism with bridge. The tongue is lowered until the piston rod end of the folding cylinder is seated in the slot of the sliding frame of the folding mechanism. The tongue is then lowered farther until the outboard pick-up pins rest on the pick-up slots of the bridge, and the trailer is backed up until the pick-up pins are seated in the pick-up slots. This will require supervision by an operator on the ground. Estimated time is 60 seconds.
6. Deploy and lower outriggers. Estimated time is 30 seconds.
7. Raise bridge off near bank. The tongue actuating cylinders are partially retracted, lifting the bridge until the inboard pick-up pins are aligned with the pick-up sockets in the toes of the bridge ramps. Estimated time is 20 seconds.
8. Engage pick-up pins. The hydraulic motor is actuated, causing the lead screws to move the pick-up slides outward. This drives the inboard pick-up pins into the sockets in the toes of the bridge ramps, and the outboard pick-up pins through the pick-up slots into sockets in the girder sides. Estimated time is 15 seconds.
9. Retract folding cylinder. This step is done only if the bridge is being picked up at the opposite end from which it was launched. Estimated time is 20 seconds.

10. Raise and fold bridge. The tongue actuating cylinders are retracted to lift the bridge off the far bank. The folding cylinder is then allowed to extend against pressure to control the folding mechanism as the weight of the ramp folds the bridge. Simultaneously, the tongue cylinders are retracted, lifting the bridge to a vertical position. Estimated time is 90 seconds.
11. Lower bridge onto trailer. The boom actuating cylinders are retracted to rotate the boom and lower the bridge. Estimated time is 30 seconds.
12. Raise and stow outriggers. Estimated time is 15 seconds.
13. Shut off power unit engine and drive away. Estimated total retrieval time is:
 - o From launch end: 5.7 minutes.
 - o From opposite end: 6.5 minutes.

5.0 TASK IIIA. FLIP-LAUNCH BRIDGE

5.1 System Characteristics

This system concept is illustrated in preliminary design form in Appendix A, Drawing E-4193-010, Sheet 1. It utilizes a bridge with two upwardly folding ramps that are folded and unfolded by mechanisms actuated by hydraulic cylinders mounted on the trailer. The bridge is launched by the cantilever method, using a fully automatic remotely controlled mechanism actuated by hydraulic cylinders and motors powered by a diesel-engine-driven supply unit mounted on the trailer. The trailer is required to have telescoping rails so that the tow vehicle can be moved forward to provide clearance to unfold the forward ramp of the bridge.

5.2 Bridge

The dimensions of the bridge are as follows:

Span: 24 meters 78 ft, 9 in.

Overall Length: 81 ft, 3 in.

Roadway Width: 126 in.

Overall Width (including curbs): 130 in.

Air Transport Width: 110 in.

Ground Transport Width: 138 in.

The bridge comprises a center section and two upwardly folding ramps with geared pivots in the deck. The basic construction of the center section and ramps is the same as the Task I bridge, each section having two treadways connected by cross-bracing. Each treadway is made up of an extruded 7005-T53 aluminum deck of the same design as in Task I and two bottom chords of extruded 7005-T53 aluminum, connected by reinforced webs fabricated from 6061-T6 aluminum sheet. The ramps are locked in the unfolded position by shot pins which connect the lower chords. The shot pins are operated by pinning mechanisms actuated by the folding mechanisms. The bridge is

narrowed for air transport by means of detachable deck edge extensions, as in the Task I concept. However, in this case, because the deck surfaces fold against each other, the curbs must be capable of folding flat when the bridge ramps are folded. In the folded position, the curbs extend 4 in. beyond the edge of the deck extensions on both sides, adding a total of 8 in. to the overall width for ground transport.

5.3 Launch Mechanism

Several mechanisms, mounted on the trailer and remotely controlled from the tow vehicle, are needed to launch and retrieve the flip-launch bridge:

- o Ramp folding mechanism. This mechanism consists of two hydraulic cylinders, each raised to engage with the bridge folding mechanism by a small hydraulic cylinder.
- o Bridge launching drive. This pair of pinions is driven by a hydraulic motor through a gearbox. The pinions engage with racks on the bridge to launch or retrieve the bridge.
- o Bridge lowering arm. This arm is pivoted at the rear of the trailer and is supported by two chains actuated by hydraulic cylinders.
- o Outriggers. Two separately controlled telescoping hydraulic outriggers are pivoted at the rear of the trailer. Each is deployed by a small hydraulic cylinder.
- o Telescoping rail locks. The telescoping rails of the trailer are locked in travel or launch position by two shot pins actuated by small hydraulic cylinders.
- o Lunette height adjustment. A lead screw driven by a hydraulic motor is provided to lower the front end of the trailer to the ground as required during launch under some bank conditions.

5.4 Launch Sequence (Appendix A, Drawing E-4193-010, Sheet 2)

1. Position trailer. This step is accomplished while communicating with observing personnel in an accompanying vehicle.
2. Start power supply engine. This step is done from inside the tow vehicle by using the glow plug switch and starter push button on the remote control panel. It can be done while the trailer is being moved into position.
3. Lower front of trailer. The front end of the trailer is lowered to ground level, using the lunette height adjusting lead screw. Estimated time is 15 seconds.
4. Deploy outriggers. The outriggers are deployed and lowered far enough to fix the trailer in position. Estimated time is 15 seconds.
5. Extend trailer rails. The lock pins are removed from the trailer rails, and the tow vehicle is driven forward to pull the rails out to their extended position. Estimated time is 30 seconds.
6. Position outriggers. The outriggers are lowered as required to level the trailer laterally and to raise the rear end of the trailer high enough so that the far end of the bridge will be above the far bank when the bridge is extended across the gap. Estimated time is 30 seconds.
7. Unfold bridge ramps. The piston rods of the ramp folding cylinders are extended, and the slotted piston rod ends are raised to engage with the cross-pins in the sliding links of the ramp folding mechanism. The pistons are then retracted, and the sliding links actuate the ramp folding arms. These arms act as levers to raise the ramps to the

vertical position. As the ramps become vertical, the rollers at the lower end of the arms enter guide tracks on the side of the bridge girders. As the ramps are lowered to the extended position, the arms act as compression members, with their lower ends guided by the tracks. Estimated time is 90 seconds.

8. Lock ramps. The ramps are locked in the extended position by pinning mechanisms similar to those used in the reinforced dry support bridge described in U.S. Army MERADCOM Report 2301, June 1980.¹ These mechanisms are actuated by pintles mounted on the ramp folding arms, which are telescoping members containing heavy compression springs which urge the arms toward their extended position. As the ramps descend with the hydraulic pistons resisting, the springs are compressed. When the ramps are fully down, the pistons are then fully retracted, and the resulting final motion of the outer sections of the arms actuates the pinning mechanisms. The ramp folding cylinders are lowered. Estimated time is 10 seconds.

9. Launch bridge. The bridge is launched across the gap by the launching drive. This pair of pinions are driven by a hydraulic motor through a gear reducer that is mounted between the trailer rails at the rear. The chains have projected lugs which engage drive racks attached to the edge of each inner girder of the bridge. The bridge is supported by rollers on the frame of the trailer. As the bridge approaches the fully extended position, it is supported only by the rollers mounted on the sides of the launch arm, which engage continuous tracks attached to the lower inside edges of the bridge girders. Estimated time is 60 seconds.

1. "System of Bridges for 1985 and Beyond - U.S. Technical Feasibility Tests; Part 4A: Reinforced Dry-Support Bridge -- Structural," U.S. Army MERADCOM, Report No. 2301, June 1980.

10. Back up tow vehicle. In cases of extreme bank conditions (i.e., far bank is higher than the near bank, and the near bank sloping is toward the gap), it will be necessary to back up the tow vehicle during the launching operation to telescope the trailer rails so that by the time the toe of the bridge ramp clears the front end of the fixed portion of the trailer frame, the rails will be fully telescoped to their travel position. This, in combination with the compound outriggers being fully extended, causes the trailer frame to assume an angle of approximately 10 degrees. This angle is required to launch the bridge sufficiently upward to compensate for the combination of maximum bank differential height (approximately 8 ft), maximum slope toward the gap (equivalent to approximately 8 ft at the far end), bridge droop at maximum extension (approximately 2 ft at the far end), and trailer frame deflection (equivalent to approximately 2.5 ft at the far end).

11. Lower far end of bridge. When the bridge is fully extended across the gap, the launching drive is stopped. The far end of the bridge is lowered to the ground by raising the outriggers, which lowers the trailer tires to the ground. Estimated time is 30 seconds.

12. Move trailer forward. The tow vehicle is driven forward a short distance until the bridge ramp is clear of the trailer and outriggers, with the near end of the bridge supported only by the rollers of the launch arm. Estimated time is 15 seconds.

13. Lower near end of bridge. The launch arm is lowered, lowering the near end of the bridge to the ground. Estimated time is 15 seconds.

14. Disengage launch arm from bridge. The tow vehicle is driven forward to disengage the launch arm rollers from the bridge tracks. The launch arm is raised. Estimated time is 15 seconds.
15. Stow telescoping rails. The outriggers are lowered to fix the trailer in position, and the tow vehicle is backed up to push the telescoping rails into the trailer frame. The lock pins are inserted. This step will not have to be done at this point if bank conditions made it necessary during the launch. Estimated time is 30 seconds.
16. Shut off power unit and drive away. Estimated total launch time is 6 minutes.

5.5 Retrieval Sequence

1. Position trailer. This step requires communicating with personnel on the ground or in an accompanying vehicle.
2. Start power unit engine.
3. Lower launch arm. Estimated time is 15 seconds.
4. Engage launch arm with bridge. The tow vehicle is backed up to engage the rollers of the launch arm in the tracks of the bridge. Estimated time is 15 seconds.
5. Deploy outriggers. The outriggers are deployed and lowered as required to level the trailer. Estimated time is 15 seconds.
6. Extend trailer rails. The lock pins are removed from the trailer rails, and the tow vehicle is driven forward to extend the rails. If required by extreme bank conditions as described in Step 10 of the launch sequence, the front

end of the trailer is lowered to the low hitch position, and the trailer rails are not extended until the bridge has been partially withdrawn.

7. Lift near end of bridge. The launch arm is raised, lifting the near end of the bridge. Estimated time is 30 seconds.
8. Lift far end of bridge. The outriggers are extended, lifting the far end of the bridge off the ground. Estimated time is 30 seconds.
9. Retrieve bridge. The launching drive pulls the bridge onto the trailer. Estimated time is 60 seconds.
10. Lower rear end of trailer. The outriggers are actuated to lower the rear end of the trailer, but with the outriggers still fixing the trailer in position. Estimated time is 15 seconds.
11. Fold ramps. The ramp folding cylinders are raised until the piston rod ends are engaged with the sliding links. The piston rods are extended, first causing the folding arms to actuate the pinning mechanism to unlock the ramps and then folding the ramps into the stowed position. Estimated time is 90 seconds.
12. Stow trailer rails. The tow vehicle is backed up, pushing the trailer rails into the stowed position, and the lock pins are re-inserted. Estimated time is 15 seconds.
13. Raise and stow outriggers, and return lunette to towing height. Estimated time is 15 seconds.
14. Shut off power unit and drive away. Total estimated retrieval time is 5.3 minutes.

6.0 TASK IIIB. BEAM-LAUNCH BRIDGE

6.1 System Characteristics

This system concept is illustrated in preliminary design form in Appendix A, Drawing E-4193-011, Sheet 1. It utilizes a bridge similar basically to the Task IIIA flip-launch bridge, with two hinged ramps which are folded and unfolded by hydraulic cylinders mounted on the trailer. The launching method is, however, different from the cantilever launch used in the flip-launch concept. A light telescoping beam, which is part of the trailer frame, is extended across the gap and set down on the far bank. The bridge is then unfolded and rolled across the launch beam, the telescoping beam is retracted, and the near end of the bridge is set down. The principal advantage of this concept is that it avoids the heavy bending moments and loads at the fulcrum that are present in all the other concepts because of their cantilever launching method.

6.2 Bridge

The dimensions of this bridge are as follows:

Span: 24 meters (78 ft, 9 in.)

Overall Length: 81 ft, 1 in.

Roadway Width: 126 in.

Overall Width (including curbs): 130 in.

Air Transport Width: 110 in.

Ground Transport Width: 138 in.

The bridge comprises a center section and two upwardly folding ramps with geared pivots in the deck. The basic construction of the center section and ramps is the same as the Task I bridge, each section having two treadways connected by cross-bracing. Each treadway is made up of an extruded 7005-T53 aluminum deck of the same design as in Task I, and two bottom chords of extruded 7005-T53 aluminum, connected by reinforced webs fabricated from

PRECEDING PAGE BLANK-NOT FILLED

6061-T6 aluminum sheet. The ramps are locked in the unfolded position by shot pins which connect the lower chords, operated by pinning mechanisms actuated by the folding mechanisms. The bridge is narrowed for air transport by means of detachable edge extensions, as in the Task I concept. However, in this case, because the deck surfaces fold against each other, the curbs must be capable of folding flat when the bridge ramps are folded. In the folded position, the curbs extend 4 in. beyond the edges of the deck extensions on both sides, adding a total of 8 in. to the overall width for ground transport.

6.3 Launch Mechanism

Several mechanisms, mounted on the trailer and remotely controlled from the tow vehicle, are needed to launch the retrieve the beam-launch bridge:

- o Ramp folding mechanism. This mechanism consists of two hydraulic cylinders, each raised to engage with the bridge folding mechanism by a small hydraulic cylinder.

- o Launch beam and drives. This beam consists of three movable rectangular sections telescoped within a stationary fourth section which is part of the trailer frame. A chain drive actuated through a gearbox by a hydraulic motor extends the first movable section. The sprockets of the chain drive are mounted on the stationary beam section, and the lower strands of chain are attached to the first movable beam section. A wire rope drive with sheaves mounted on the first section extends the second section. The lower strands of the rope are attached to the stationary section and the upper strands to the second section. Similarly, the third section is extended by a wire rope drive with sheaves mounted on the second section and the upper strands attached to the third section. All sections move simultaneously until the beam is fully extended.

- o Bridge launching drive. This pair of chains is driven by a hydraulic motor by means of a gearbox mounted under the main beam of the trailer. Projecting pins on the chains engage drive slots attached to the lower inside edge of each inner girder of the bridge. Rollers mounted on the cross-braces which rest on the top of the launch beam support the bridge.
- o Bridge lowering arms. These arms are pivoted in the rear of the trailer and are actuated by hydraulic cylinders trunnion-mounted on the trailer frame.
- o Outriggers. Two separately controlled telescoping hydraulic outriggers are pivoted at the rear of the trailer, each deployed by a small hydraulic cylinder.

6.4 Launch Sequence (Appendix A, Drawing E-4193-011, Sheet 2)

1. Position trailer. This step is accomplished while communicating with observing personnel in an accompanying vehicle.
2. Start power supply engine. This step is done from inside the tow vehicle using the glow plug switch and starter push button on the remote control panel. It can be done while the trailer is being moved into position.
3. Unhitch trailer and lower front end. The tow vehicle is detached from the trailer and moved forward to provide clearance to unfold the front bridge ramp. The front end of the trailer is lowered to the ground. Estimated time is 60 seconds.
4. Deploy and position outriggers. The outriggers are deployed and lowered as required to level the trailer laterally and to raise the rear end of the trailer high

enough so that the launch beam will be above the far bank when extended across the gap. Estimated time is 45 seconds.

5. Extend launch beam. The telescoping launch beam is extended across the gap by its drive. Estimated time is 60 seconds.
6. Lower launch beam. The outriggers are retracted, setting the end of the launch beam down on the far bank. Estimated time is 15 seconds.
7. Unfold bridge ramps. The piston rods of the ramp folding cylinders are extended, and the slotted piston rod ends are raised to engage with the cross-pins in the sliding links of the ramp folding mechanism. The pistons are then retracted, and the sliding links actuate the ramp folding arms. These arms act as levers to raise the ramps to the vertical position. As the ramps approach vertical, the rollers at the lower end of the arms enter guide tracks on the side of the bridge girders. As the ramps are lowered to the extended position, the arms act as compression members, with their lower ends guided by the tracks. Estimated time is 90 seconds.
8. Lock ramps. The ramps are locked in the extended position by pinning mechanisms similar to those used in the reinforced dry support bridge described in the U.S. Army MERADCOM Report 2301, June 1980.¹ These mechanisms are actuated by pintles mounted on the ramp folding arms, which are telescoping members containing heavy compression springs which urge the arms toward their extended position. As the ramps descend with the hydraulic pistons resisting, the springs are compressed. When the ramps are

1. Ibid.

fully down, the pistons are then fully retracted, and the resulting final motion of the outer sections of the arms actuates the pinning mechanisms. The ramp folding cylinders are lowered. Estimated time is 10 seconds.

9. Launch bridge. The bridge is driven across the beam by the launching drive. Estimated time is 60 seconds.
10. Retract launch beam. When the bridge reaches the far side of the gap, the launching drive is stopped, and the launch beam is fully retracted into the trailer frame, leaving the far end of the bridge resting on the bank. Estimated time is 60 seconds.
11. Lower bridge. The launch arms actuated by two hydraulic cylinders lower the near end of the bridge to the ground. Estimated time is 15 seconds.
12. Stow outriggers. Estimated time is 15 seconds.
13. Hitch trailer. The tow vehicle is backed up, and the tow hitch is re-engaged. Estimated time is 60 seconds.
14. Disengage launch arms from bridge. The trailer is moved forward to disengage the launch arms from the lift points of the bridge. The launch arms are raised. Estimated time is 15 seconds.
15. Shut off power unit engine and drive away. Total estimated launch time is 8.2 minutes.

6.5 Retrieval Sequence

1. Position trailer. This step requires communicating with personnel on the ground or in an accompanying vehicle.

2. Start power unit engine.
3. Lower launch arm. Estimated time is 15 seconds.
4. Engage launch arm with bridge. The tow vehicle is backed up to engage the rollers of the launch arm in the tracks of the bridge. Estimated time is 15 seconds.
5. Deploy outriggers. The outriggers are deployed and lowered as required to level the trailer. Estimated time is 15 seconds.
6. Unhitch trailer. The tow vehicle is detached from the trailer and moved forward to provide clearance to retrieve the bridge. Estimated time is 60 seconds.
7. Lift bridge. The launch arms raise the near end of the bridge until the upper surface of the tracks attached to the inner sides of the bridge girders contacts the rollers at the outer end of the launch beam, and the drive pins of the launch drive engage in the drive slots on the bridge girders. Estimated time is 30 seconds.
8. Extend launch beam. The launch beam is fully extended. Its far end is being supported by rollers at the end of the beam riding on the tracks on the bridge girders. Estimated time is 60 seconds.
9. Retrieve bridge. The launch drive pulls the bridge back across the launch beam. Estimated time is 60 seconds.
10. Lift launch beam. The outriggers are lowered as required to lift the far end of the launch beam off the ground. Estimated time is 30 seconds.
11. Retract launch beam. Estimated time is 60 seconds.

12. Raise and stow outriggers. Estimated time is 15 seconds.
13. Fold ramps. The ramp actuating cylinders are raised until the piston rod ends engage with the sliding links. The piston rods are extended, first making the actuating arms cause the pinning mechanisms to unlock the ramps, and then moving the ramps into the stowed position. Estimated time is 90 seconds.
14. Hitch trailer. The tow vehicle is backed up, and the tow hitch is re-engaged. Estimated time is 60 seconds.
15. Shut off power unit and drive away. Total estimated retrieval time is 8.5 minutes.

7.0 TASK IIIC1. DOUBLE-SCISSORS BRIDGE

7.1 System Characteristics

This system concept is illustrated in preliminary design form in Appendix A, Drawing E-4193-012. It incorporates features which provide the following advantages over the Task I and II scissors bridges:

- o Improved cross-country mobility characteristics as a result of the reduced overall length of the bridge and trailer.
- o Lower profile during launch and retrieval. This double-fold scissors-type bridge has two sets of geared hinges in the bottom chords, and two folding linkages, each actuated by two hydraulic cylinders mounted on the bridge. The overhead cantilever method launches the bridge by a fully automatic, remote-controlled mechanism actuated by hydraulic cylinders. These cylinders are powered by a diesel-engine-driven supply unit mounted on the trailer.

7.2 Bridge

The dimensions of this bridge are as follows:

Span: 60 ft

Overall Length: 62 ft, 6 in.

Roadway Width: 126 in.

Overall Width (including curbs): 130 in.

Air Transport Width: 110 in.

Ground Transport Width: 130 in.

The basic design of the bridge is similar to the Task I scissors bridge except for the following changes:

- o Addition of a second set of folding hinges in the bottom chords.
- o Addition of a second folding mechanism. The folding mechanism for this bridge must be designed for heavier loads, since the unfolding moments will be approximately 2.1 times greater than those for the Task I bridge. Because of the heavier loads, two 5 in. cylinders are needed to actuate each folding mechanism, compared with one 5 in. cylinder for the single folding mechanism in the Task I bridge.
- o Modification of the folding linkages to handle compression loads in the translating links. In this design, one bridge ramp must be folded up under the center span during retrieval. The translating link must carry a compression load during this part of the retrieval sequence; in the Task I concept, the translating link is required to carry only tension. As shown in the drawing, arcuate tracks were added around the pivot points for the rotating links. These tracks guide rollers attached to the expanding links, restraining them from expanding into the range of the linkage positions in which the translating link is required to carry a compression load. The expanding links are, however, free to expand when necessary to permit the ramps to be fully unfolded.

7.3 Launch Mechanism

The launch mechanism is similar to the Task I preliminary design, but was modified to fold more compactly in the stowed position on the trailer so that the bridge rests directly on the trailer bed. To accomplish this, the actuating cylinders for the boom and tongue are located between, rather than in line with, the longitudinal members of the boom and tongue.

7.4 Launch Sequence (Appendix A, Drawing E-4193-012, Sheet 2)

1. Position trailer. This step is accomplished while communicating with observing personnel in an accompanying vehicle.
2. Start power supply engine. This step is done from inside the tow vehicle using the glow plug switch and starter push button on the remote control panel. It can be done while the trailer is being moved into position.
3. Deploy outriggers. Hydraulic cylinders rotate the outriggers to a vertical position. The cylinders are controlled by a solenoid valve actuated from within the tow vehicle by 3-position (extend-off-retract) push buttons on the remote control panel. (All of the following launch functions are controlled in the same way.) Estimated time is 15 seconds.
4. Lower outriggers to level the trailer laterally. The outriggers are controlled separately. Estimated time is 30 seconds.
5. Launch bridge. The operator coordinates actuation of the boom, tongue, and both pairs of folding cylinders to raise and unfold the bridge simultaneously and to set it down on the far bank. Estimated time is 180 seconds.
6. Retract lock pins. Hydraulic cylinders retract the lock pins, disengaging them from the pick-up sockets in the toes of the bridge ramps. Estimated time is 5 seconds.
7. Lower bridge on near bank. The tongue cylinders are extended as required to set the bridge down on the near bank. On a bank with lateral slope, adjusting the outriggers may be necessary to lower the bridge to an equilibrium position. Estimated time is 10 seconds.

8. Raise and stow outriggers. Estimated time is 15 seconds.
9. Disengage launch mechanism from bridge. The trailer is towed forward to withdraw the tongue cross-pin from the pick-up slots in the bridge and to break the hydraulic connections. This step can be done before the outriggers are fully stowed. Estimated time is 15 seconds.
10. Stow launch mechanism. Boom and tongue actuating cylinders are retracted. (This step can be done while driving away.) Estimated time is 80 seconds.
11. Shut off power unit and drive away. Estimated total launch time is 4.5 minutes.

7.5 Retrieval Sequence

1. Position trailer. This step requires communicating with personnel on the ground or in an accompanying vehicle.
2. Start power unit engine.
3. Extend boom and tongue actuating cylinders. Estimated time is 80 seconds.
4. Engage launch mechanism with bridge. This step is done by lowering the tongue and backing up the trailer until the cross-pin of the tongue is seated in the pick-up slots of the bridge and the hydraulic connections are engaged. Direct supervision by the operator is required. Estimated time is 60 seconds.
5. Deploy and lower outriggers. Estimated time is 30 seconds.
6. Raise bridge off near bank. The tongue actuating cylinders are partially retracted, lifting the bridge until the lock

pins are alined with the pick-up sockets in the toes of the bridge ramps. Estimated time is 20 seconds.

7. Engage lock pins. Estimated time is 5 seconds.
8. Raise and fold bridge, and stow it on trailer. The operator coordinates actuation of the boom, tongue, and both pairs of folding cylinders to raise and fold the bridge simultaneously and lower it onto the trailer. Estimated time is 3 minutes.
9. Raise and stow outriggers. Estimated time is 15 seconds.
10. Shut off power unit engine and drive away. Estimated total retrieval time is 6.5 minutes.

8.0 TASK IIIC2. DOUBLE-SCISSORS BRIDGE

8.1 System Characteristics

This system concept is illustrated in preliminary design form in Appendix A, Drawing E-4193-013. It is similar to the Task IIIC1 system except that the bridge is narrowed for loading in the C-141 aircraft by moving the treadways closer together rather than by removable deck extensions. Narrowing and widening operations are accomplished through the launch mechanism. The bridge can be widened under power after unloading from the aircraft, or it can be towed to the launch site in the narrow configuration and widened under power by remote control just before launch.

8.2 Bridge

The dimensions of this bridge are as follows:

Span: 60 ft

Overall Length: 62 ft, 6 in.

Roadway Width: 126 in.

Overall Width (including curbs): 130 in.

Air Transport Width: 110 in.

Ground Transport Width: 110 or 130 in.

The bridge is similar to the Task IIIC1 preliminary design except for the following changes:

- o The decks do not have detachable edge extensions. Each treadway has a 1-piece deck that is 45 in. wide, like the existing Army design. Upstanding curbs identical to those used in the Task I, IIA, IIB, and IIIC1 designs are attached to the outer edges of the decks by means of fasteners designed to fail under overload conditions without damaging the deck.

PRECEDING PAGE BLANK-NOT FILLED

- o Addition of hinges to the vertical braces permit the braces to fold as the bridge is narrowed for air transport. A rod connects the vertical braces of each bridge section. When the bridge is widened and unfolded, the ends of the rods in the three sections of the bridge butt each other, locking the braces in the straight position. The braces are lightly spring-loaded toward the folded position by torsion springs in the pivots to break the toggle effect at the beginning of the narrowing operation.

- o The mountings at one end of the longitudinal braces were provided with elongated slots to permit the braces to collapse as the bridge is narrowed. When the bridge is widened, the pins in the ends of the braces seat against the ends of the slots and the braces function as tension members.

8.3 Launch Mechanism

The launch mechanism is similar to the Task IIIC1 preliminary design except that a mechanism was added to narrow and widen the bridge. Two tubular cross-members were added to the tongue, each containing two cylindrical slides. The pick-up pins which engage the four pick-up sockets in the bridge are mounted on these slides. An hydraulic motor can drive these slides inward or outward by two lead screws driven through a connecting shaft and gearboxes, narrowing the bridge for air transport or widening it for deployment, while the pick-up pins remain engaged in the pick-up sockets. The lead screws are protected from dust and dirt by flexible accordion-type boots.

8.4 Launch Sequence (Appendix A, Drawing E-4193-012, Sheet 2)

1. Position trailer. This step is accomplished while communicating with observing personnel in an accompanying vehicle.

2. Start power supply engine. This step is done from inside the tow vehicle using the glow plug switch and starter push button on the remote control panel. It can be done while the trailer is being moved into position.
3. Deploy outriggers. Hydraulic cylinders rotate the outriggers to a vertical position. The cylinders are controlled by a solenoid valve actuated from within the tow vehicle by 3-position (extend-off-retract) push buttons on the remote control panel. (All of the following launch functions are controlled in the same way.) Estimated time is 15 seconds.
4. Lower outriggers to level the trailer laterally. The outriggers are controlled separately. Estimated time is 30 seconds.
5. Widen bridge to 130 in. This step can be done, if desired, at any time before reaching the launch site. The boom cylinders are actuated to lift the bridge slightly off the supports. The hydraulic motor is then operated to rotate the lead screws and drive the bridge to its full width. During the widening operation, the two sides of the bridge are maintained parallel by the vertical braces, which are interconnected by rods as described above. Estimated time is 30 seconds.
6. Launch bridge. The operator coordinates actuation of the boom, tongue, and both pairs of folding cylinders to raise and unfold the bridge simultaneously and set it down on the far bank. Estimated time is 180 seconds.
7. Withdraw pick-up pins from sockets in toes of bridge ramp. The hydraulic motor is actuated, causing the lead screws to move the pick-up slides inward. In this position, the inboard pick-up pins are withdrawn from the sockets in the

ramp toes, but the outboard pick-up pins remain engaged with the pick-up slots on the sides of the bridge girders. Thus, the near end of the bridge is still supported by the outboard pick-up pins. Estimated time is 15 seconds.

8. Lower bridge on near bank. The tongue cylinders are extended as required to set the bridge down on the near bank. On a bank with lateral slope, adjusting the outriggers may be necessary to lower the bridge to an equilibrium position. Estimated time is 10 seconds.
9. Raise and stow outriggers. Estimated time is 15 seconds.
10. Disengage outboard pick-up pins from bridge. The trailer is towed forward to withdraw the outboard pick-up pins from the pick-up slots in the bridge. This step can be done before the outriggers are completely stowed. Estimated time is 15 seconds.
11. Stow launch mechanism. Boom and tongue actuating cylinders are retracted. (This step can be done while driving away.) Estimated time is 80 seconds.
12. Shut off power unit engine and drive away. Estimated launch time is as follows:
 - o 4.7 minutes if the bridge is widened before reaching the launch site.
 - o 5.2 minutes if the bridge is widened at the launch site.

8.5 Retrieval Sequence

1. Position trailer. This step requires communicating with personnel on the ground or in an accompanying vehicle.

2. Start power unit engine.
3. Extend boom and tongue actuating cylinders. Estimated time is 80 seconds.
4. Engage launch mechanism with bridge. The tongue is lowered until the outboard pick-up pins rest on the pick-up slots of the bridge, and the trailer is backed up until the outboard pick-up pins are seated in the pick-up slots. This step requires supervision by an operator on the ground. Estimated time is 60 seconds.
5. Deploy and lower outriggers. Estimated time is 30 seconds.
6. Raise bridge off near bank. The tongue actuating cylinders are partially retracted, lifting the bridge until the inboard pick-up pins are aligned with the pick-up sockets in the toes of the bridge ramps. Estimated time is 20 seconds.
7. Engage pick-up pins. The hydraulic motor is actuated, causing the lead screws to move the pick-up slides outward. This drives the inboard pick-up pins into the sockets in the toes of the bridge ramps, and the outboard pick-up pins through the pick-up slots into sockets in the girder sides. Estimated time is 15 seconds.
8. Raise and fold bridge, and stow it on trailer. The operator coordinates actuation of the boom, tongue, and both pairs of folding cylinders to raise and fold the bridge simultaneously and lower it onto the trailer. Estimated time is 3 minutes.
9. Raise and stow outriggers. Estimated time is 3 minutes.
10. Shut off power unit engine and drive away. Estimated total retrieval time is 6.7 minutes.

9.0 TRAILER

9.1 Required Characteristics

The special requirements of the assault bridge system preclude the use of a standard commercially available trailer with only minor modification. The trailer is (to a greater degree in some of the concepts than in others) an integral part of the launch and retrieval system and will require special design that should consider the characteristics described below.

9.1.1 Frame Construction

During launch and retrieval, a heavy bending moment is exerted on the trailer frame because of the cantilever method of handling the bridge, except for the Task IIIB beam-launch bridge. The longitudinal frame members of the trailer must therefore be designed for greater strength than would be required if their only function were to carry the payload. In addition, provision must be made to house the hydraulic power supply system in front of the bridge; this provision requires special frame construction in the drawbar area. Meeting these requirements with an efficient, low-weight structure compatible with air transport necessitates special design of the trailer frame for the application.

The trailer frames for the scissors and double-scissors bridge systems, as shown in the preliminary design drawings, are fabricated from 6061-T6 aluminum I and channel sections. Approximately equivalent weight can be achieved by steel construction, using formed sections of T-1 high strength steel.

The Task IIIA flip-launch and IIIB beam-launch bridge systems require additional unusual trailer frame design. The flip-launch bridge trailer frame has dual longitudinal rectangular tubular beams to accommodate the required telescoping drawbar rails. The beam-launch bridge trailer frame is built around a large, central, rectangular tubular beam which houses the telescoping launch traverse beam.

9.1.2 Running Gear and Suspension

Because of the poor cross-country mobility characteristics inherent in varying degrees in the concepts as a result of the overall length and configuration of the bridge/trailer combination, the design of the suspension requires special attention. The preliminary design drawings indicate two suspension innovations to enhance cross-country mobility.

The first is the use of a 2-position attachment of the suspension to the trailer frame. Each preliminary design drawing shows, in solid lines, the position of the wheels for ground transport. Also shown, in phantom lines, is a second wheel position, farther to the rear and higher, which is used for air transport. The ground transport position limits the static load on the tow hitch to 1000 lb, and raises the trailer frame to improve approach and departure angles and to provide clearance for suspension deflection. Loading the system into C-141 aircraft in that configuration would not be feasible. Therefore, before loading, the front jackpost and rear outriggers are deployed and lowered to jack up the trailer frame and take the weight off the suspension. The running gear is then detached from the frame and moved to the rear air transport position.

In the scissors bridge, flip-launch, and beam-launch concepts, the two positions are far enough apart so that the suspension can simply be bolted to the frame at the two positions. In the double-scissors bridge concept, the two positions are so close together that the difference in height would have to be achieved by means of removable spacers or by pinned connections to side plates extending downward from the frame.

The preliminary design drawings indicate a 6 in. difference in height between the air transport position and the ground transport position. A greater increase in height would further improve approach and departure angles, but at the expense of a higher center of gravity. The prototype trailers should be designed to permit the testing of different suspension heights to determine the optimum height for best overall cross-country mobility characteristics.

The second innovation is the use of an 8-wheel leaf spring suspension (except in the Task IIIC1 and IIIC2 concepts) to provide high-flotation characteristics. The use of this suspension is not feasible in the Task IIIC1 and IIIC2 concepts because of the shorter trailer; there would be interference between the inner wheels and the launch mechanism. This suspension, shown in an existing trailer design in Figure 2, comprises two independent units, each having four 12.00-16.50 tires, which are mounted directly under longitudinal frame members of each side of the trailer. Each of these units is highly flexible about the lateral and longitudinal axes, as shown in Figure 3, assuring excellent load distribution among the tires. The fact that the suspension is made up of two separate units facilitates the repositioning of the running gear for air transport. The disadvantages of the 8-wheel suspension are the added weight and cost: the 8-wheel, 12.00-16.50 tire suspension is estimated to be approximately 2200 lb heavier than a more conventional 4-wheel suspension using 14.00-17.50 tires. A suspension of this type in an existing trailer design is illustrated in Figures 4 and 5.

The 4-wheel suspension would have adequate load capacity for the scissors and double-scissors bridges, but not for the flip-launch and beam-launch bridges. The cross-country mobility characteristics of the 4-wheel suspension would presumably not be as good as those of the 8-wheel suspension. It would be possible to test both types of suspension in the prototype systems (except for the Task IIIC1 and IIIC2 concepts) to determine whether the 8-wheel suspension provides enough mobility improvement to justify the weight and cost trade-offs.

Both suspension innovations described above, the 2-position suspension and the 8-wheel suspension, were suggested by a representative of Eidal International Corporation, Albuquerque, New Mexico, and Figures 2 through 5 are included through the courtesy of that company. Eidal International provided the most helpful information of the trailer manufacturers contacted during the study. Also, Eidal has successfully applied the 8-wheel suspension in oil field equipment trailers.

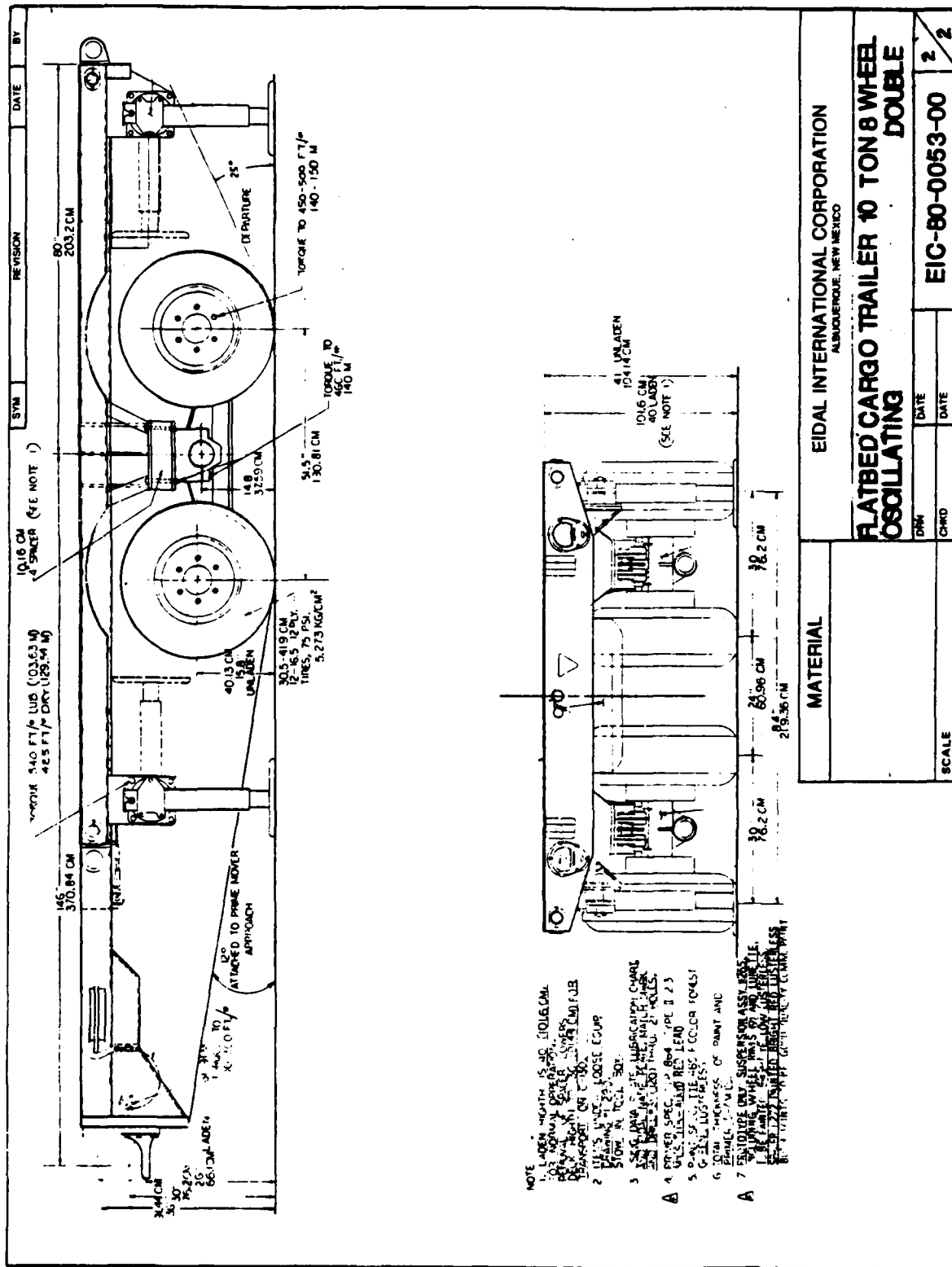
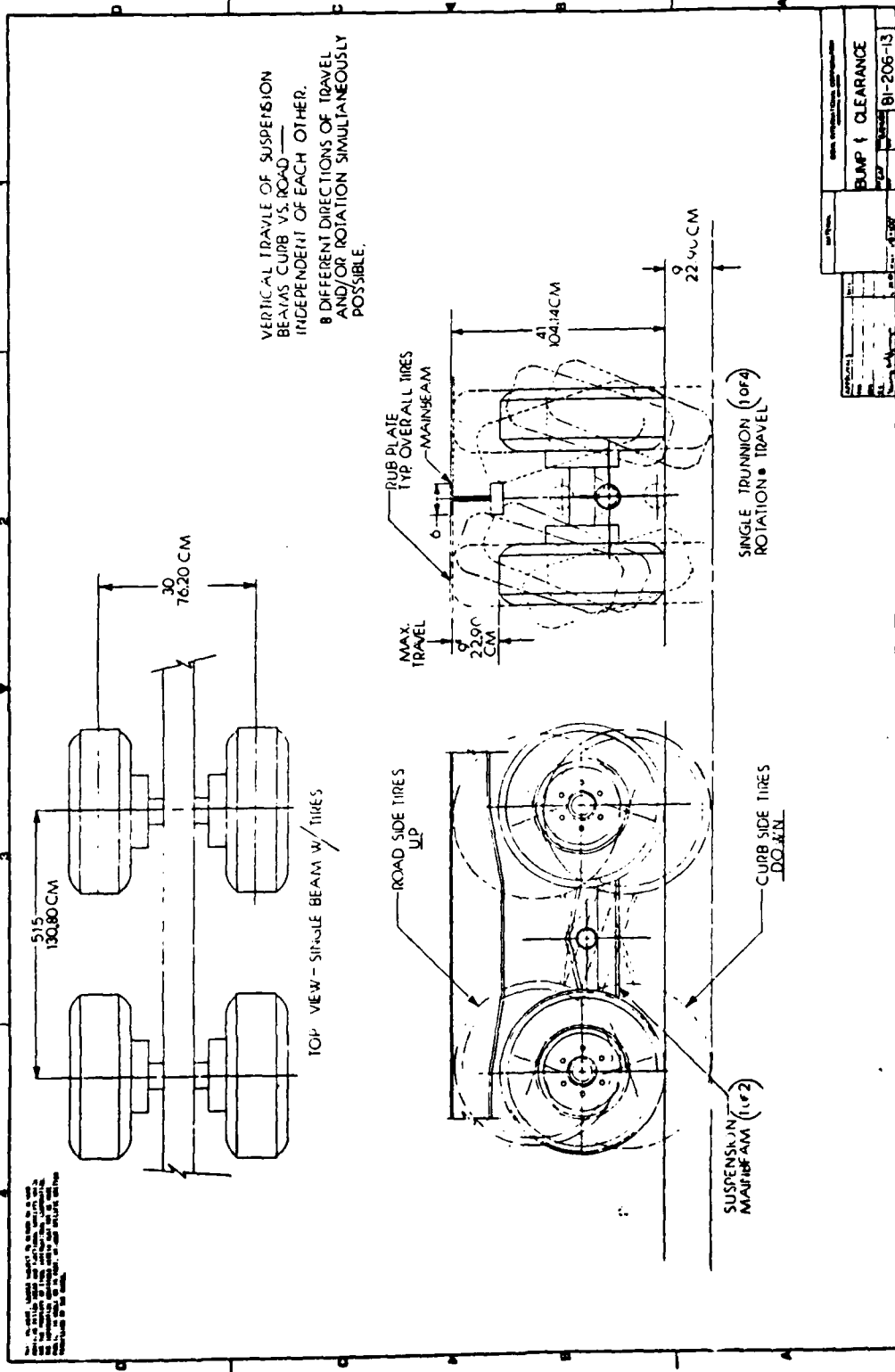

FIGURE 2 EXISTING TRAILER DESIGN, 8-WHEEL SUSPENSION



Enclosure 5

FIGURE 3 DEFLECTION CHARACTERISTICS OF 8-WHEEL SUSPENSION



FIGURE 5 EXISTING 4-WHEEL SUSPENSION DESIGN

Source: Eidal International Corporation, Albuquerque, New Mexico

9.1.3 Tow Hitch

The tow lunette requires sufficient vertical adjustment to accommodate the difference in height among the tow pintles of all of the potential tow vehicles. In all concepts except the Task I, IIA, and IIB scissors bridges, an additional, substantial vertical adjustment of the lunette is required during loading in C-141 aircraft to avoid interference between the rear of the bridge and the top of the cargo space. A rack and pinion mechanism actuated by handcrank through a small gearbox can provide this adjustment. It can also be used to position the lunette for towing, which is locked in place by a bolted clamp for ground transport. In the case of the Task I, IIA, and IIB scissors bridge concepts, the lunette can simply be bolted to the front of the drawbar at different heights to accommodate the tow vehicles.

In all concepts except the Task IIIB beam-launch system, a large upward force is exerted on the tow hitch during the cantilever launch. This force amounts to approximately 3600 lb for the single-scissors bridges and 8700 lb for the double-scissors bridges. The lunette assembly will have to be designed for this load, and all potential tow vehicles will have to be checked to determine whether their tow pintle mountings are capable of accepting the load.

9.1.4 Brakes

Since the tracked tow vehicles will not have an air supply available on-board to actuate trailer brakes, a hydraulic surge or inertial braking system will have to be provided. Surge brakes will complicate the design of the lunette assembly, and surge braking may not be adequate in view of the mass of the system. Also, because of the mass of the tow vehicle, it is not certain that trailer braking will be necessary with tracked vehicles. During detailed design of the system, braking requirements will have to be carefully analyzed to select and specify the most appropriate braking method. There are three evident possibilities at this time:

- o Surge brakes only, for both wheeled and tracked tow vehicles.

- o Air brakes only; no braking when towed by a tracked vehicle.
- o Hydraulic brakes, actuated by an air-over-hydraulic system when the tow vehicle has an air supply, and by surge when no air supply is available.

9.2 Compliance with MIL-C-52437B(ME)

The trailer for the assault bridge system will conform with many of the requirements of MIL-C-52437B(ME), Military Specification, Chassis, Trailer, Single- and Multi-Axle, Class CCE, Size 14. However, it will have to deviate from several of these requirements to meet the special needs of this application. These deviations include:

- o Trailer curb weight. Keeping trailer curb weight within the specified 4000 lb maximum does not appear feasible. Preliminary estimates of the trailer weight for the various system concepts range from 6000 to 9700 lb, depending upon the type of suspension used.
- o Overall length. Only the trailer for the double-scissors bridge concepts (Tasks IIIC1 and IIIC2) meets the maximum trailer length specification of 300 in.
- o Overall width. The trailers for all concepts exceed the maximum width specification of 96 in. The running gear should utilize the full 110 in. width permitted by aircraft loading restrictions to achieve maximum stability in cross-country travel.
- o Trailer bed height. Because of the great overall length of bridge and trailer, raising the bed height far above the specified 30 in. maximum is necessary to achieve approach and departure angles which are reasonable for cross-country travel.

10.0 HYDRAULIC POWER SUPPLY

All system concepts utilize the same hydraulic power supply unit design. This unit is powered by a 4-cylinder air-cooled diesel engine which must be capable of an output of approximately 27 horsepower (hp) at 2000 revolutions per minute (rpm) on an intermittent-duty basis. The engine incorporates a glow-plug starting system and solenoid-actuated electric starter. The engine is directly coupled to a hydraulic vane pump capable of delivering 10 gallons per minute (gpm) at 2000 rpm at a continuous pressure of 2500 pounds per square inch (psi) and an intermittent pressure of 3000 psi. A pilot-operated relief valve controls system pressure. A 20 gallon reservoir is required.

The control valves are 3-position closed-center double-solenoid valves actuated by remote control from the cable-connected control panel. A total of 9 to 12 control valves is required, depending upon the concept.

For maximum protection, the hydraulic power supply unit is located between the main longitudinal beams of the trailer. To estimate the weight, we assumed that the unit would be protected by 1 in. aluminum armor on all sides and on the top.

PRECEDING PAGE BLANK-NOT FILMED

11.0 AIR TRANSPORT

11.1 Conformity with Requirements

The draft ROC requires that the light assault bridge be transportable in the C-141 family of aircraft. Permissible preparation time for aircraft loading is 30 minutes, and permissible time to prepare the bridge system for ground transport after off-loading from the aircraft is 30 minutes.

All of the preliminary designs described in Chapters 2 through 8 are capable of meeting these requirements. However, the air transportability characteristics of the concepts differ, primarily with respect to the preparation time required before loading and after off-loading, and the degree of difficulty of the loading and off-loading operations. The air transportability characteristics of the concepts are discussed and compared in Chapter 13.

In all concepts, the trailer with the bridge in place can be loaded in and off-loaded from the C-141 aircraft by its tow vehicle, and can be transported without exceeding the load or space limitations of the aircraft. If the tow vehicle and trailer are to be transported together, the tow vehicle can be driven forward up the loading ramp into the aircraft, towing the trailer behind it. If the tow vehicle is not to be transported, it can push the trailer backward up the ramp into the aircraft.

11.2 Preparation for Loading

In all concepts, two operations must be performed to prepare the trailer and bridge for air transport. These operations are as follows:

1. Moving the trailer running gear to a position to the rear of and higher than the ground transport position. The purpose of this operation is to reduce the rear overhang and the rear height of the bridge on the trailer to avoid

interferences with the ground, loading ramp, or top of the cargo space. This operation must be performed for all concepts if the trailer is to be pushed backwards into the aircraft, but only in the Task IIIA and IIIB concepts if the tow vehicle and trailer are to be driven forward into the aircraft. To move the running gear, the trailer is jacked up to take the weight off the suspension, using the outriggers at the rear, actuated by the hydraulic power unit and a manually operated jackpost at the front. The running gear is then unbolted from the trailer frame and rolled to the air transport position, the trailer is lowered, and the running gear is rebolted to the frame.

2. Narrowing the bridge from its full deployed width of 130 in to the air transport width of 110 in. In the Task I, IIA, IIIA, IIIB, and IIIC1 concepts, this operation is done by manually removing and stowing the detachable deck edge extensions as described in Chapter 2. In the Task IIB and IIIC2 concepts, it is accomplished under power by operating the launch mechanism to raise the bridge slightly off the trailer and actuating the bridge narrowing mechanism to move the treadways inward. The details of bridge and launch mechanism design required to accomplish this are described in Chapter 4.

The estimated times required to prepare the system for both forward and backward loading in the aircraft is included in Chapter 13 for all concepts.

11.3 Loading Procedure

11.3.1 Forward Loading

In all concepts, the tow vehicle is driven forward up the loading ramp, with the trailer following. In all cases, the required 6 in. clearance from door and cargo compartment sides and top is maintained.

In all except the Task IIIC1 and IIIC2 concepts, there is little clearance between the ground and the rear end of the bridge or trailer when the trailer wheels are just starting up the ramp. However, even if there is some contact with the ground in that position, it should not be a problem.

11.3.2 Rearward Loading

In all concepts, with the running gear in the air transport position, the trailer can be pushed backward onto the loading ramp by the tow vehicle without the rear end of the bridge or trailer striking the ramp. In the Task I, IIA, and IIB concepts, the trailer can be pushed up the ramp and into the cargo compartment without any adjustments being made during the process. In the Task I concept, the rear end of the bridge clears the top of the cargo space by approximately 4 in., while in the Task IIA and IIB concepts, the specified 6 in. clearance is maintained. In the Task IIIA, IIIB, IIIC1, and IIIC2 concepts, the front of the trailer must be raised when the trailer has reached the point where its wheels are approaching the top of the ramp. This step is necessary to avoid interference between the top rear end of the bridge and the top of the cargo compartment. It is accomplished by vertical adjustment of the trailer lunette, using a manually operated mechanism as described in Chapter 9. At the time this adjustment must be made, the tow hitch is readily accessible from ground level. Figures 6 through 12 show, for each concept, the critical position where there is minimum clearance between the rear end of the bridge and the top of the cargo space. The amount of lunette adjustment required to maintain a 6 in. clearance from the top of the cargo compartment is shown for each concept in these figures. When the loading operation has been completed, the tow hitch is uncoupled, and the tow vehicle drives down the ramp.

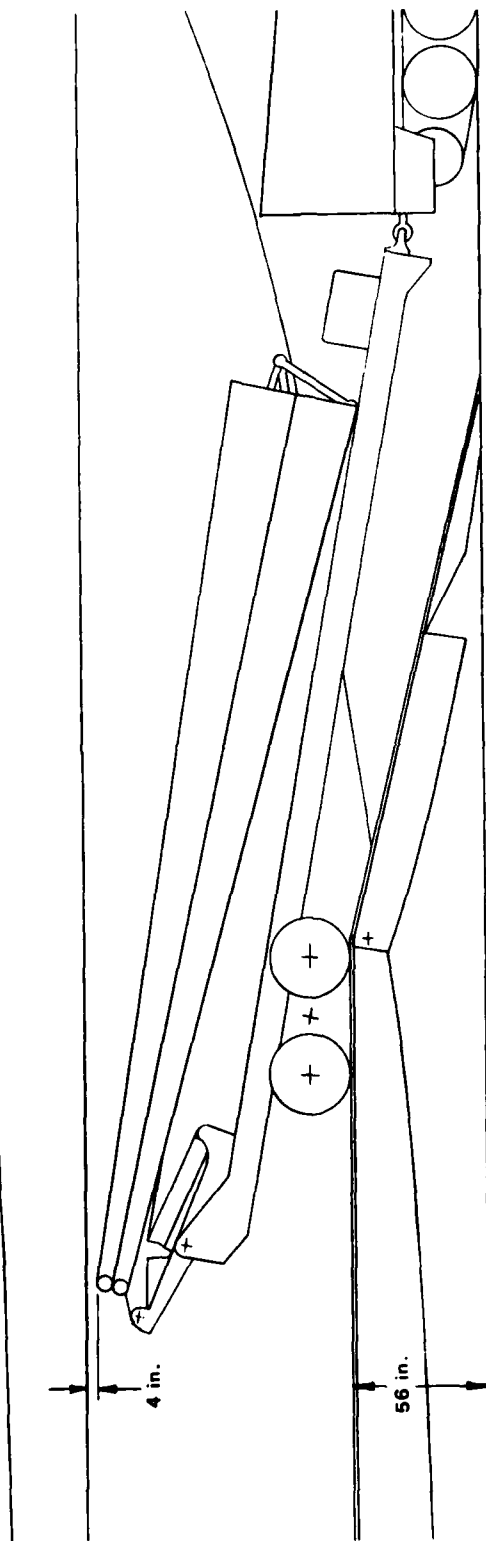

FIGURE 6 TASK I SCISSORS BRIDGE: REARWARD LOADING INTO C-141 AIRCRAFT

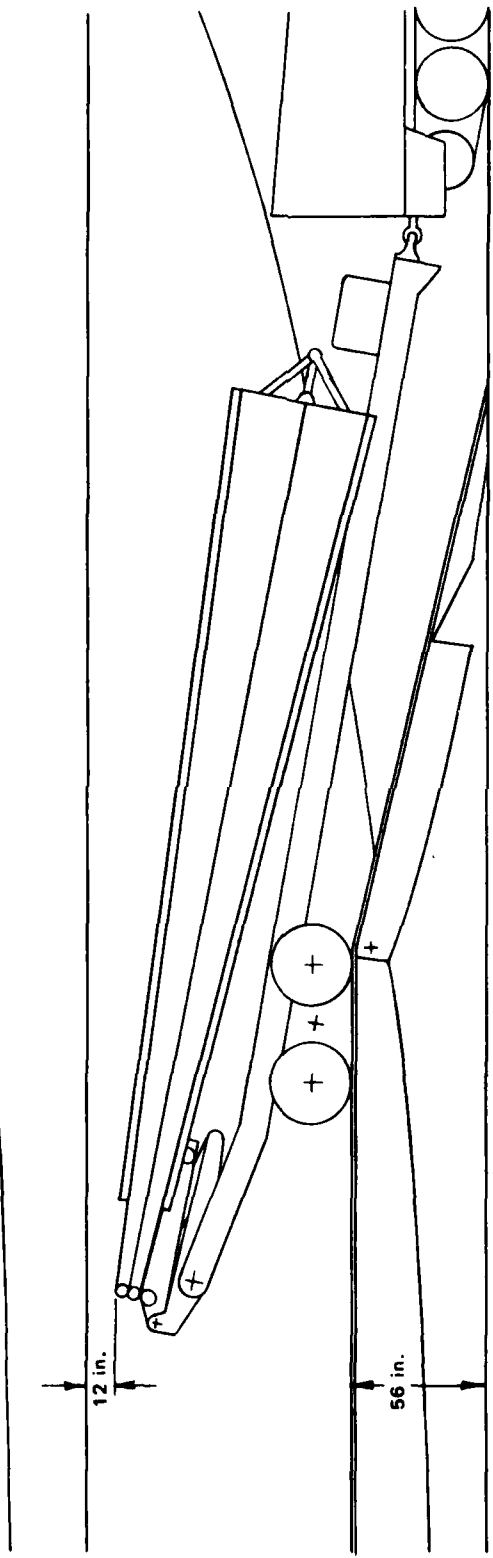

FIGURE 7 TASK IIA SCISSORS BRIDGE: REARWARD LOADING INTO C-141 AIRCRAFT

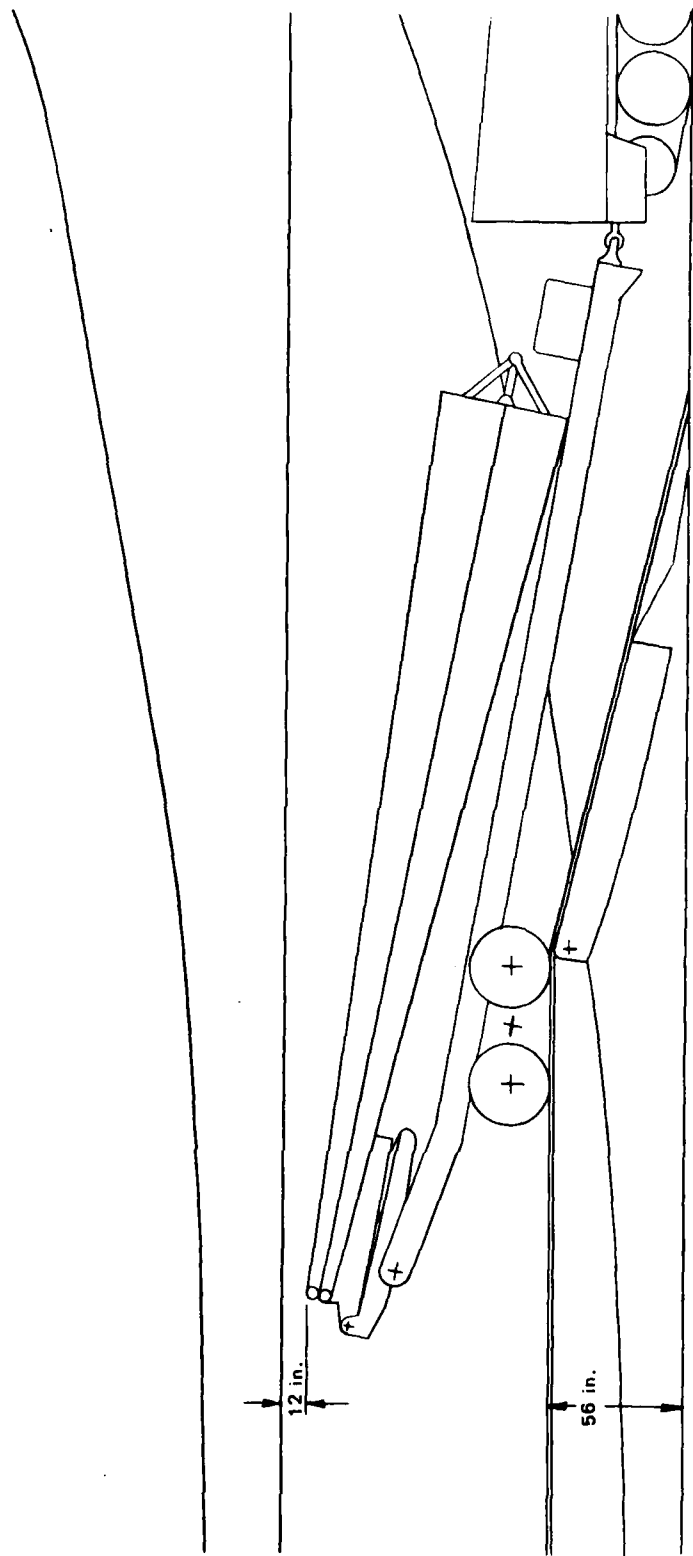

FIGURE 8 TASK IIB SCISSORS BRIDGE: REARWARD LOADING INTO C-141 AIRCRAFT

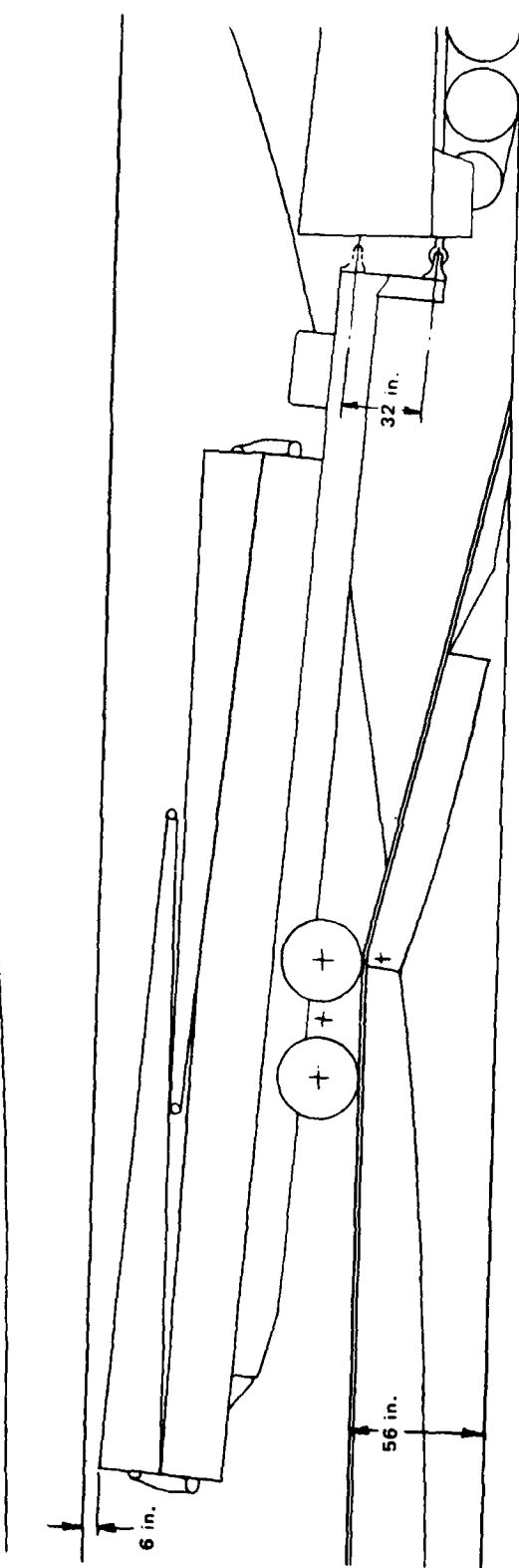

FIGURE 9 TASK IIIA FLIP-LAUNCH BRIDGE: REARWARD LOADING INTO C-141 AIRCRAFT

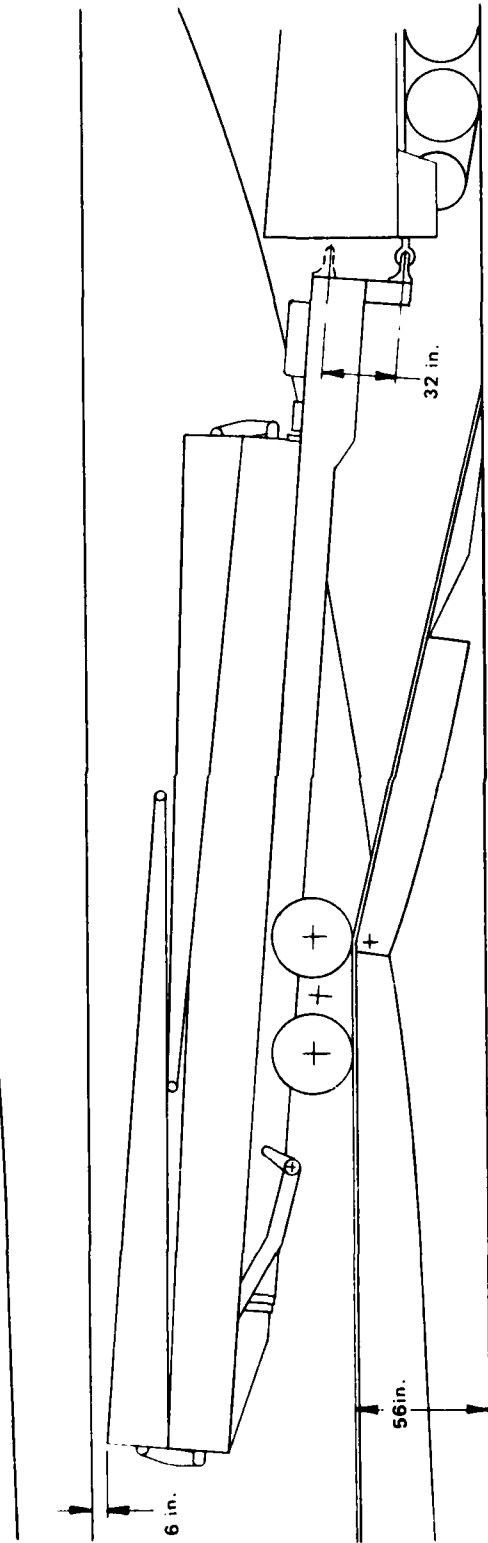

FIGURE 10 TASK IIIB BEAM LAUNCH BRIDGE: REARWARD LOADING INTO C-141 AIRCRAFT

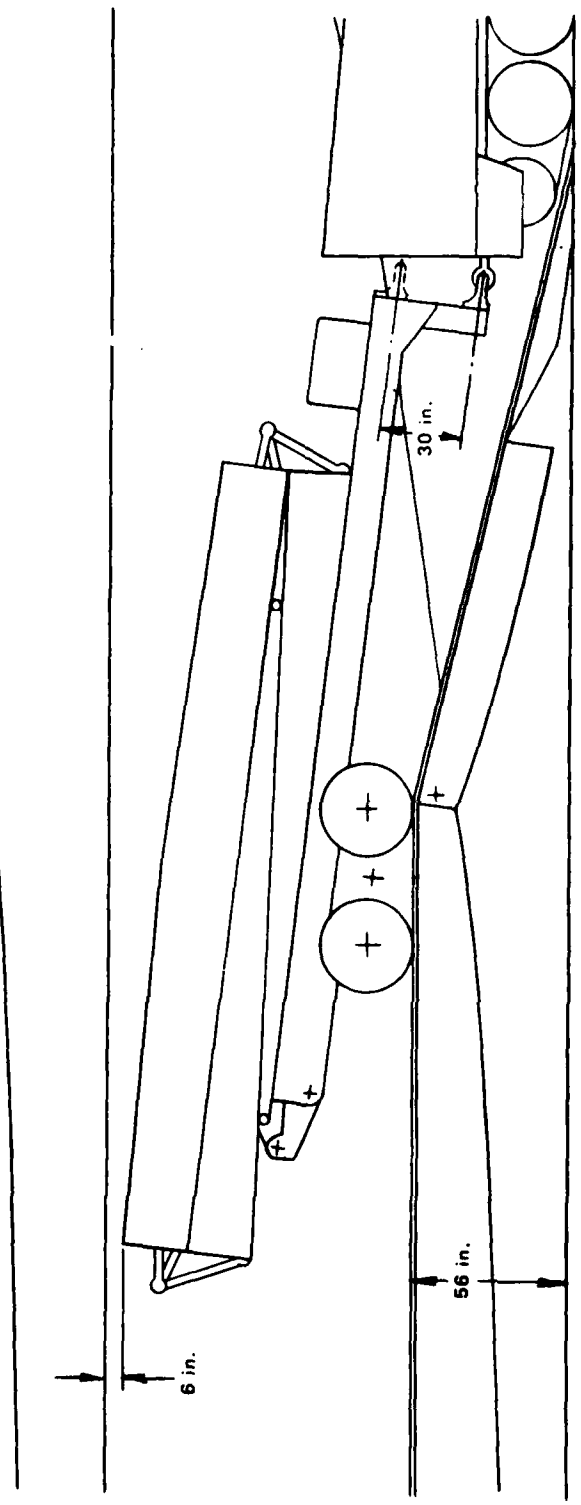

FIGURE 11 TASK III C1 DOUBLE-SCISSORS BRIDGE: REARWARD LOADING INTO C-141 AIRCRAFT

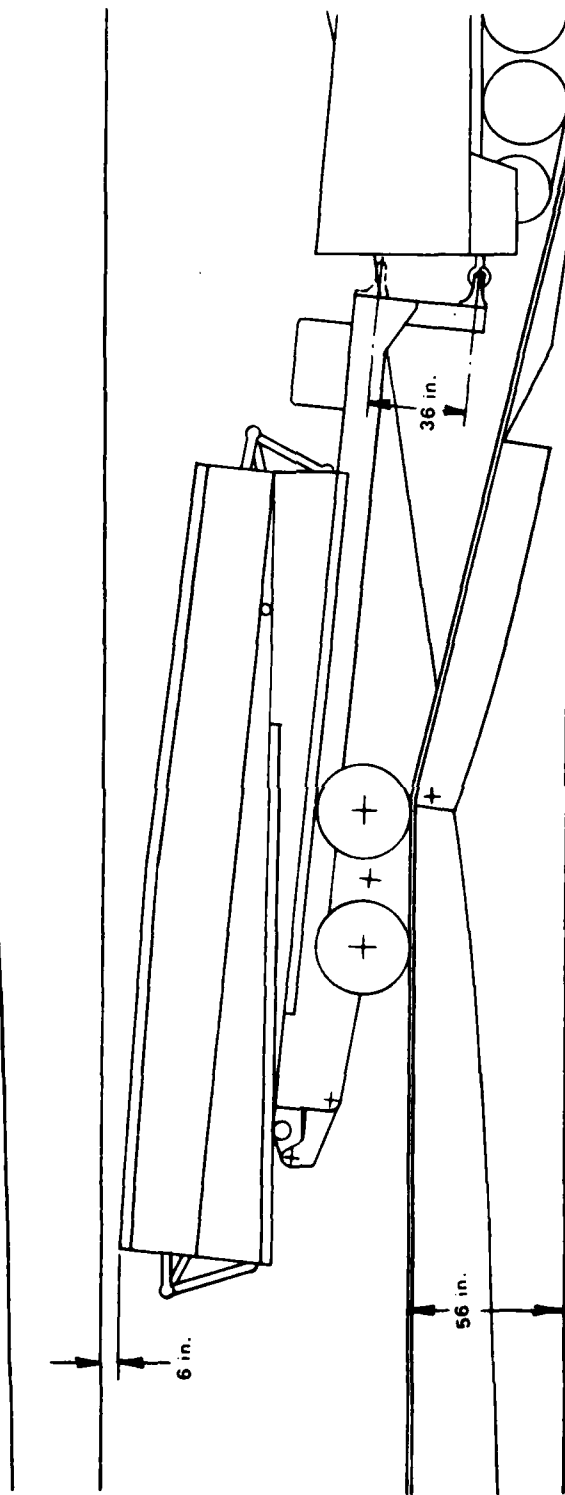

FIGURE 12 TASK III C2 DOUBLE-SCISSORS BRIDGE: REARWARD LOADING INTO C-141 AIRCRAFT

11.4 Off-Loading Procedure

11.4.1 Off-Loading After Forward Loading

When the tow vehicle and trailer are loaded by the forward loading procedure, they are unloaded by backing the tow vehicle out of the aircraft and down the ramp, with the trailer preceding the vehicle. In all except the Task IIIC1 and IIIC2 concepts, as the trailer wheels approach the bottom of the ramp, there is close clearance and possibly some contact between the rear end of the bridge or trailer and the ground.

11.4.2 Off-Loading After Rearward Loading

When the trailer is loaded by the rearward loading procedure, the first steps in off-loading are to back the tow vehicle up the ramp and couple the tow hitch. The tow vehicle is then driven down the ramp, pulling the trailer behind it. In the Task IA, IIA, and IIB concepts, no adjustments are required during this operation. In the Task IIIA, IIIB, IIIC1, and IIIC2 concepts, at a point when the trailer wheels are part way down the ramp, the lunette must be returned to its normal towing height, using the manual procedure described in Section 11.3.2. This step must be done before the trailer wheels reach the bottom of the ramp or the rear end of the bridge or trailer will strike the ramp.

11.5 Preparation for Ground Transport

After off-loading the system, if the trailer running gear is in the air transport position it must be moved to the ground transport position by the method described in Section 11.2. In addition, the bridge must be widened to its deployed width. In concepts IA, IIA, IIIA, IIIB, and IIIC1, this is done by manually attaching deck edge extensions as described in Chapter 2. In concepts IIB and IIIC2, it is accomplished under power by the launch mechanism, reversing the

procedure described in Section 11.2. However, in concepts IIB and IIIC2, deployment of the bridge to operating width may be delayed until reaching the launch site, if desired. The estimated time required to prepare the system for ground transport after off-loading is the same as the preparation time for loading shown in Table 15 in Chapter 13 for all concepts.

12.0 COST ESTIMATES

12.1 Introduction

The cost for design and construction of two prototype systems was estimated for each of the system concepts described in Chapters 2 through 8. Table 2 in Chapter 1 summarized these estimates; Tables 4 through 10 presents the estimates in more detail for each concept.

12.2 Methodology

12.2.1 Development Costs

Design tasks were listed for each concept, and engineering, design, and detail drafting times were estimated for each task. Parametric costs were calculated at \$40 per hour, including overhead, G&A, and fee. The development cost includes a rough estimate of the time of contractor personnel and should be used only for relative comparisons between bridging systems. The cost of time spent by government personnel is not included.

12.2.2 Construction Costs

The drawings of the Army design of the bridge and launch mechanism were used to estimate the costs of the Task I scissors-bridge concept. Included were materials and labor costs for making each part, and labor cost for assembly and checkout. This Task I estimate was then used as the baseline cost for estimating the other concepts. For the other scissors and double-scissors-bridge concepts, the costs of additional parts and operations were estimated and added to the baseline cost. For the flip-launch and beam-launch bridge concepts, material and labor costs were extrapolated from the baseline cost estimate, using factors based on relative size and weight.

TABLE 4. ESTIMATED COST, TASK I SCISSORS BRIDGE

	Bridge		Launch Mechanism		Total System		Total 2 Systems	
	Hr	Cost	Hr	Cost	Hr	Cost	Hr	Cost
Development Costs: ^a								
Engineering ^b	280	11,200	640	25,600			920	36,800
Design ^b	320	12,800	520	20,800			840	33,600
Detailing ^b	240	9,600	440	17,600			680	27,200
Sub-Total	840	33,600	1,600	64,000			2,440	97,600
Tooling								75,000 ^c
Debugging & Rework								61,600 ^c
Total Development								234,200
Construction Costs:								
Raw Materials		27,400 ^d		3,800 ^d		31,200		62,400
Purchased Components		2,200		22,000		24,200		48,400
Hardware & Misc.		1,100		3,300		4,400		8,800
Spare Parts								11,400
Sub-Total		30,700		29,100		59,800		131,000
Labor ^b	1,400	56,000	1,000	40,000	2,400	96,000	4,800	192,000
Sub-Total		86,700		69,100		155,800		323,000
Set-Up Charges						50,000		20,000
Trailer								100,000
Total Construction								443,000
Total Cost								677,200

^aTo be used only for relative comparisons between bridges.

^b\$40 per hour, including overhead, G&A, and fee.

^c10% x total costs.

^dIncludes 20% scrap allowance.

TABLE 5. ESTIMATED COST, TASK IIA SCISSORS BRIDGE

	Bridge		Launch Mechanism		Total Systems	
	Hr	Cost	Hr	Cost	1 System	2 Systems
Development Costs: ^a						
Engineering ^b	360	14,400	660	26,400		40,800
Design ^b	400	16,000	630	25,200		41,200
Detailing ^b	340	13,600	610	24,400		38,000
Sub-Total	1,100	44,000	1,900	76,000		120,000
Tooling						75,000 ^c
Debugging & Rework						87,300 ^c
Total Development						282,300
Construction Costs:						
Raw Materials		27,900 ^d		4,800 ^d		32,700
Purchased Components				24,200		24,200
Hardware & Misc.		700		3,700		4,400
Spare Parts						11,300
Sub-Total		28,600		32,700		61,300
Labor ^b	1,460	58,400	1,020	40,800	2,480	99,200
Sub-Total		87,000		73,500		160,500
Set-Up Charges						20,000
Trailer						50,000
Total Construction						100,000
Total Cost						452,300
						734,600

^aTo be used only for relative comparisons between bridges.

^b\$40 per hour including overhead, G&A, and fee.

^c15% x (labor & materials) + 10% x (tooling + setup + trailer).

^dincludes 20% scrap allowance.

TABLE 6. ESTIMATED COST, TASK IIB SCISSORS BRIDGE

	Bridge		Launch Mechanism		Total Systems	
	Hr	Cost	Hr	Cost	1 System	2 Systems
<u>Development Costs:</u> ^a						
Engineering ^b	390	15,600	740	29,600		45,200
Design ^b	370	18,800	790	31,600		50,400
Detailing ^b	410	16,400	770	30,800		47,200
Sub-Total	1,270	50,800	2,300	92,000		142,800
Tooling						68,000
Debugging & Rework						117,600 ^c
Total Development						328,400
<u>Construction Costs:</u>						
Raw Materials		28,100 ^d		4,800 ^d	32,900	65,800
Purchased Components				25,900	25,900	51,800
Hardware & Misc.		700		4,000	4,700	9,400
Spare Parts						12,200
Sub-Total		28,800		34,700	63,500	139,500
Labor ^b	1,460	58,400	1,200	48,000	106,400	212,800
Sub-Total		87,200		82,700	169,900	352,000
Set-Up Charges					50,000	18,000
Trailer						100,000
Total Construction						470,000
Total Cost						798,400

^aTo be used only for relative comparisons between bridges.

^b\$40 per hour including overhead, G&A, and fee.

^c20% x (labor + materials) + 10% x (tooling + setup + trailer).

^dIncludes 20% scrap allowance.

TABLE 7. ESTIMATED COST, TASK IIIA FLIP-LAUNCH BRIDGE

	Bridge		Launch Mechanism		Total	
	Hr	Cost	Hr	Cost	1 System	2 Systems
Development Costs: ^a						
Engineering ^b	920	36,800	920	36,800		73,600
Design ^b	960	38,400	840	33,600		72,000
Detailing ^b	880	35,200	870	34,800		70,000
Sub-Total	2,760	110,400	2,630	105,200		215,600
Tooling						70,000
Debugging & Rework						234,600 ^c
Total Development						520,200
Construction Costs:						
Raw Materials		38,300 ^d		3,800 ^d	42,100	84,200
Purchased Components				22,000	22,000	44,000
Hardware & Misc.		2,700		3,300	6,000	12,000
Spare Parts						11,200
Sub-Total		41,000		29,100	70,100	151,400
Labor ^b	2,700	108,000	1,000	40,000	3,700	296,000
Sub-Total		108,000		40,000	148,000	447,400
Set-Up Charges					75,000	18,000
Trailer						150,000
Total Construction						615,400
Total Cost						1,135,600

^aTo be used only for relative comparisons between bridges.

^b\$40 per hour including overhead, G&A, and fee.

^c30% x (labor & materials) + 15% x (tooling + setup + trailer).

^dIncludes 20% scrap allowance.

TABLE 8. ESTIMATED COST, TASK IIIB BEAM-LAUNCH BRIDGE

	Bridge		Launch Mechanism		1 System		2 Systems	
	Hr	Cost	Hr	Cost	Hr	Cost	Hr	Cost
Development Costs:^a								
Engineering ^b	860	34,400	1,120	44,800			1,980	79,200
Design ^b	960	38,400	1,070	42,800			2,030	81,200
Detailing ^b	880	35,200	1,090	43,600			1,970	78,800
Sub-Total	2,700	108,000	3,280	131,200			5,980	239,200
Tooling								85,000
Debugging & Rework								293,900 ^c
Total Development								618,100
Construction Costs:								
Raw Materials		37,200 ^d		7,000 ^d		44,200		88,400
Purchased Components				22,000		22,000		44,000
Hardware & Misc.		1,500		5,500		7,000		14,000
Spare Parts								11,600
Sub-Total		38,700		34,500		73,200		158,000
Labor ^b	2,050	82,000	2,000	80,000	4,050	162,000	8,100	324,000
Sub-Total		120,700		114,500		235,200		482,000
Set-Up Charges						65,000		18,000
Trailer								130,000
Total Construction								630,000
Total Cost								1,248,100

^aTo be used only for relative comparisons between bridges.

^b\$40 per hour including overhead, G&A, and fee.

^c35% x (labor + materials) + 15% x (tooling + setup) + 20% trailer.

^dIncludes 20% scrap allowance.

TABLE 9. ESTIMATED COST, TASK I11C1 DOUBLE-SCISSORS BRIDGE

	Bridge		Launch Mechanism		Total	
	Hr	Cost	Hr	Cost	1 System	2 Systems
Development Costs:^a						
Engineering ^b	440	17,600	660	26,400	1,100	44,000
Design ^b	560	22,400	630	25,200	1,190	47,600
Detailing ^b	500	20,000	610	24,400	1,110	44,400
Sub-Total	1,500	60,000	1,900	76,000	3,400	136,000
Tooling						75,000
Debugging & Rework						122,800 ^c
Total Development						333,800
Construction Costs:						
Raw Materials		28,200 ^d		2,200 ^d		60,800
Purchased Components		9,000		22,000		62,000
Hardware & Misc.		2,000		3,300		10,600
Spare Parts						14,500
Sub-Total		39,300		27,500		147,900
Labor ^b	1,850	74,000	1,060	42,400	2,910	232,800
Sub-Total		113,200		69,900		380,700
Set-Up Charges						20,000
Trailer						100,000
Total Construction						500,700
Total Cost						834,500

^aTo be used only for relative comparisons between bridges.

^b\$40 per hour, including overhead, G&A, and fee.

^c20% x (labor + materials) + 10% x (tooling + setup + trailer).

^dIncludes 20% scrap allowance.

TABLE 10. ESTIMATED COST, TASK IIIC2 DOUBLE-SCISSORS BRIDGE

	Bridge		Launch Mechanism		Total Systems	
	Hr	Cost	Hr	Cost	1 System	2 Systems
Development Costs:^a						
Engineering ^b	470	18,800	740	29,600		48,400
Design ^b	630	25,200	790	31,600		56,800
Detailing ^b	570	22,800	770	30,800		53,600
Sub-Total	1,670	66,800	2,300	92,000		158,800
Tooling						70,000
Debugging & Rework						162,800 ^c
Total Development						391,600
Construction Costs:						
Raw Materials		28,800 ^d		4,800		33,600
Purchased Components		9,000		23,700		32,700
Hardware & Misc.		2,000		3,500		5,500
Spare Parts						15,300
Sub-Total		39,800		32,000		71,800
Labor	1,980	79,200	1,250	50,000	3,230	129,200
Sub-Total		119,000		82,000		201,000
Set-Up Charges						417,300
Trailer						18,000
Total Construction						100,000
Total Cost						535,300
						926,900

^aTo be used only for relative comparisons between bridges.

^b\$40 per hour, including overhead, G&A, and fee.

^c25% x (labor + materials) + 10% x (tooling + setup + trailer).

^dIncludes 20% scrap allowance.

The following unit costs for materials and labor were used in formulating the estimates:

o Raw materials:

Aluminum extrusions, 7005-T53	\$3.85/lb
Aluminum bar, 70750T651	3.30/lb
Aluminum sheet and plate, 6061-T6	1.90/lb
Steel, T-1, ASTM A514, Gr. F	1.30/lb
Steel, 4340	1.00/lb
Steel, 4140	0.80/lb
Steel, A36	0.80/lb

MERADCOM was the source for the cost of 7005-T53 aluminum extrusions, based on previous purchase of deck extrusions, converted to 1982 dollars. The source for the remaining raw materials was telephone quotations from local vendors, converted to 1982 dollars.

o Purchased Components: The costs of major purchased components were obtained by using telephone quotations from local vendors and converting them to 1982 dollars. Costs for hardware and miscellaneous components were estimated.

o Labor: \$40 per hour, including overhead, G&A, and fee.

12.2.3 Trailer Cost

Several trailer manufacturers produced trailer cost quotations based on preliminary drawings and applicable sections of MIL-C-52437B(ME), CCE version. These estimates ranged from \$5,400 to \$16,731 per unit, but were not considered to reflect a realistic

AD-A115 131

LITTLE (ARTHUR D) INC CAMBRIDGE MA F/8 13/2
DESIGN STUDY FOR MOUNTING THE CLASS 30 MEDIUM ARMORED VEHICLE L--ETC(U)
DEC 81 W P HIDDEN DAAK78-79-D-8036
ADL-86618-01 NL

UNCLASSIFIED

2 of 5
2 of 1

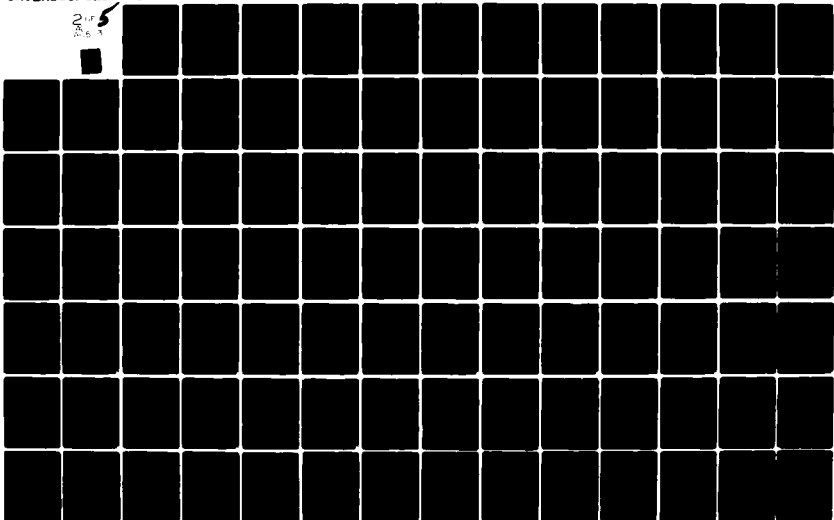

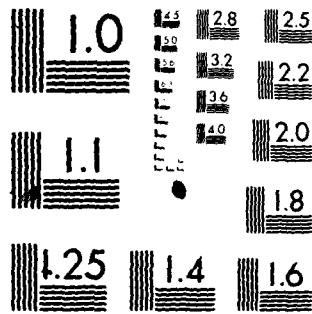

MICROCOPY RESOLUTION TEST CHART
NATIONAL BUREAU OF STANDARDS 1963-A

assessment of the special requirements of the application. The trailer manufacturer that appeared to have the best appreciation of the magnitude of the applications, Eidal International Corporation declined to submit a quotation until design details were established. Thus, with no accurate information available, ROM estimates were used for trailer cost.

13.0 COMPARISON OF SYSTEM CONCEPTS

13.1 Introduction

The characteristics used to compare the seven system concepts are discussed in this section.

13.1.1 Bridge, General Characteristics

Table 11 presents the general characteristics of the bridge for each concept. These characteristics are discussed below:

Number of Hinge Points: Self-explanatory

Ramp Folding Direction: Self-explanatory

Pinning Mechanisms: Since their hinges are in their upper surfaces, the flip-launch and beam-launch bridges require pinning mechanisms to connect the bottom chords. The scissors and double-scissors bridges, which are hinged at the bottom, require no pinning mechanisms, an advantage for simplicity and reliability reasons.

Type of Folding Mechanism: The folding mechanism in the scissors bridges must only exert tension to unfold the bridge during launch or control its folding during retrieval; gravity provides the folding force. In the flip-launch, beam-launch, and double-scissors bridge, the folding mechanisms must be capable of exerting both tension and compression forces to power the movement of the ramps in both directions, complicating the design of the folding mechanisms and resulting in the use of rollers operating in tracks.

Hydraulic Cylinders in Bridge: Locating the hydraulic cylinders that operate the folding mechanisms in the bridge

TABLE 11. BRIDGE, GENERAL CHARACTERISTICS

Characteristic	Task I	Task IIA	Task IIB	Task IIIA	Task IIIB	Task IIIC	Task IIIC2
	Scissors	Scissors	Scissors	Flip-Launch	Beam-Launch	Double Scissors	Double Scissors
No. of Hinge Points	1	1	1	2	2	2	2
Ramp Folding Direction	Down	Down	Down	Up	Up	Down	Down
Pinning Mechanisms	No	No	No	Yes	Yes	No	No
Type of Folding Mechanism	Linkage Existing Design Tension Only	Linkage Tension Only	Linkage Tension Only	Link-Beam & Track Tension and Compression	Link-Beam & Track Tension and Compression	Linkage & Track Tension and Compression	Linkage & Track Tension and Compression
Hydraulic Cylinders in Bridge	Yes	No	No	No	No	Yes	Yes
Method of Narrowing for Air Transport	Detachable Deck Edge Extensions	Detachable Deck Edge Extensions	Folding Cross-Bracing	Detachable Deck Edge Extensions	Detachable Deck Edge Extensions	Detachable Deck Edge Extensions	Folding Cross-Bracing
Curbs	Integral	Integral	Integral	Must Fold when Ramps are Folded	Must Fold when Ramps are Folded	Integral	Integral

rather than in the launch mechanism is considered a disadvantage because it requires the use of hydraulic disconnects at the launch mechanism/bridge interface, and the cylinder is exposed to damage during use of the bridge.

Method of Narrowing for Air Transport: Two methods of narrowing the bridge for air transport are used in the concepts. In one method, manually detachable deck-edge extensions are used. They are stowed on or under the trailer frame during air transport and are attached after unloading from the aircraft. In the other method, the bridge has folding cross-bracing, and the launch method is capable of narrowing and widening the bridge either under power or by handcrank. This facilitates preparing the bridge for ground travel after unloading it from the aircraft. It also permits ground transport to the launch site in the narrow configuration, if desirable.

Curbs: In the flip-launch and beam-launch bridges, since the top surfaces of the deck fold flat against each other when the ramps are folded, the curbs must be capable of folding flat when the bridge is stowed and then moving into operating position as the ramps are unfolded before launch. In the scissors and double-scissors bridges, this complication is not necessary; the curbs can be integral with the deck or deck extensions.

13.1.2 Bridge, Physical Characteristics

Table 12 presents the physical characteristics of the bridge. These characteristics for the deployed bridge are discussed below:

Span: The minimum span allowed by the draft ROC is 60 feet. A 23 meter (m) span was listed in a previous draft ROC as a desirable characteristic, but is not so listed in the revised draft ROC, dated 15 September 1981.

TABLE 12. BRIDGE, PHYSICAL CHARACTERISTICS

Characteristic	Task I	Task IIA	Task IIB	Task IIIA	Task IIIB	Task IIIC1	Task IIIC2
	Scissors	Scissors	Scissors	Flip-Launch	Beam-Launch	Double Scissors	Double Scissors
<u>Deployed:</u>							
Span	60 ft	60 ft	60 ft	24m (78ft, 9 in.)	24m (78ft, 9 in.)	60 ft	60 ft
Overall Length	62 ft, 6 in.	62 ft, 4 in.	62 ft, 4 in.	81 ft, 1 in.	81 ft, 1 in.	62 ft, 4 in.	62 ft, 4 in.
Roadway Width	3.2m (126 in.)	3.2m (126 in.)	3.2m (126 in.)	3.2m (126 in.)	3.2m (126 in.)	3.2m (126 in.)	3.2m (126 in.)
Overall Width	130 in.	130 in.	130 in.	130 in.	130 in.	130 in.	130 in.
Space Between Treadways	36 in.	36 in.	36 in.	36 in.	36 in.	36 in.	36 in.
Height, Incl. 4 in. Curbs	31 in.	31 in.	31 in.	34 in.	34 in.	31 in.	31 in.
Toe Height	6 in.	4 in.	4 in.	4 in.	4 in.	4 in.	4 in.
<u>Folded:</u>							
Length	32 ft, 6 in.	33 ft, 0 in.	33 ft, 0 in.	36 ft, 0 in.	36 ft, 0 in.	25 ft, 10 in.	25 ft, 10 in.
Width, Ground Transport	130 in.	130 in.	110 in.	136 in.	136 in.	130 in.	130 in.
Width, Air Transport	110 in.	110 in.	110 in.	110 in.	110 in.	110 in.	110 in.
Height, without Curbs	54 in.	54 in.	54 in.	50 in.	50 in.	50 in.	50 in.
Height, Incl. Curbs	62 in.	62 in.	62 in.	50 in.	50 in.	58 in.	58 in.
Weight, Estimated	7,000 lb	7,000 lb	7,100 lb	9,500 lb	9,200 lb	7,500 lb	7,600 lb

Overall Length: Self-explanatory.

Roadway Width: This clear roadway width inside the curbs is the same for all concepts.

Overall Width: This overall width including the curbs is the same for all concepts.

Space Between Treadways: This open space is not covered by infill decking and is the same for all concepts.

Height Including 4 in. Curbs: This overall height at the center of the bridge is from the bottom of the bottom chords to the top of the curbs.

Toe Height: This height is the outside diameter of the tubes which form the toes of the bridge. The Trilateral Design and Test Code requires a maximum toe height of 100 millimeters (3.94 inches).

The physical characteristics for the folded bridge are discussed below:

Length: This measurement is the folded length of the bridge only, including any projection of the folding mechanism.

Width, Ground Transport: This measurement is the overall width of the bridge only, with deck-edge extensions, if any, in place. The Task IIB and IIIC2 bridges can be transported to the launch site in either a 110 in. or a 130 in. width. The 138 in. width of the flip-launch and beam-launch bridges is due to the folded curbs.

Width, Air Transport: This measurement is the overall width of the bridge only, after preparation for air transport. It is the

same for all concepts and is within the 111 in. maximum width specified for loading in C-141 aircraft.

Height, without Curbs: This overall height of the folded bridge does not include the curbs.

Height, including Curbs: This overall height of the folding bridge includes the curbs. The curbs do not add to the folded height in the flip-launch and beam-launch bridge.

Weight, Estimated: These weight estimates are based on a calculation of the weight of the existing Army bridge design, and extrapolation based on size and feature differences to estimate bridge weights for the other concepts.

13.1.3 System, Logistical Characteristics, Air Transport

Figures 13 through 19 illustrate the air transport configurations for the seven concepts. The logistical characteristics for air transport are presented in Table 13 and are discussed below.

Weight, Estimated, with 8-Wheel, 12.00-16.50 Tire Suspension: A breakdown of the estimated weights is shown in Table 14.

Weight, Estimated, with 4-Wheel, 14.00-17.50 Tire Suspension: The 4-wheel suspension reduces system weights by 2200 lb. This suspension is not considered feasible for the flip-launch and beam-launch bridges because of their greater weights and poor cross-country mobility characteristics. There is insufficient space for the 8-wheel suspension in the double-scissors bridge concepts because of the short trailer and the configuration of the launch mechanism.

Meets C-141 Cargo Limitations: All concepts conform to overall dimensional limitations and floor loading limitations for C-141 aircraft.

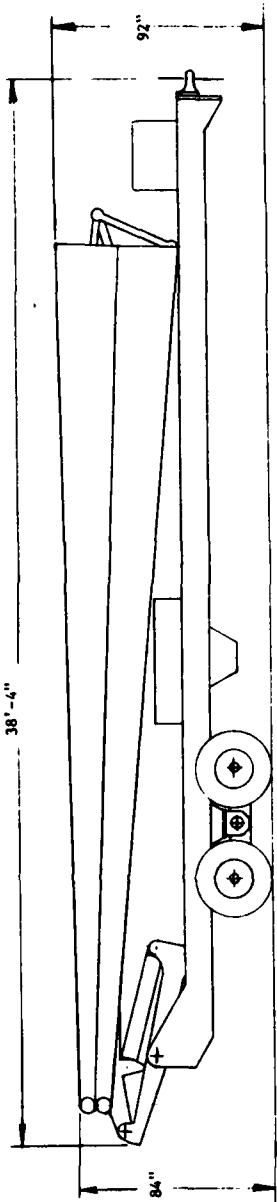

Air Transport Configuration

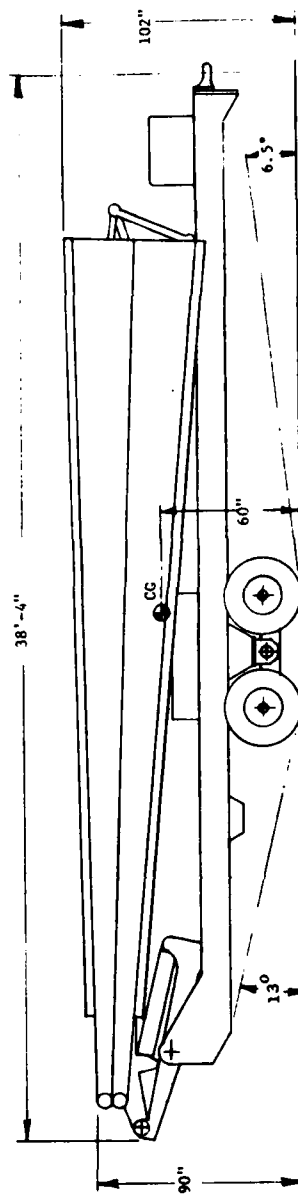

Ground Transport Configuration

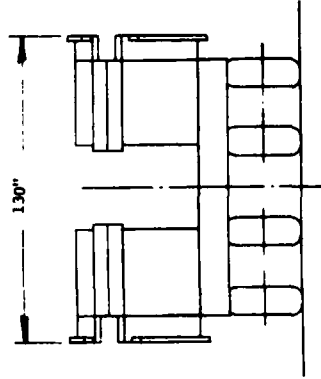
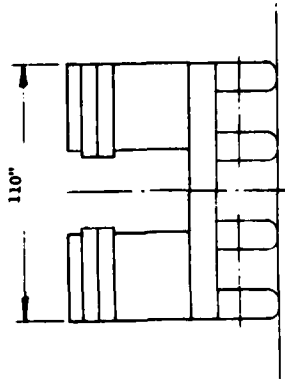
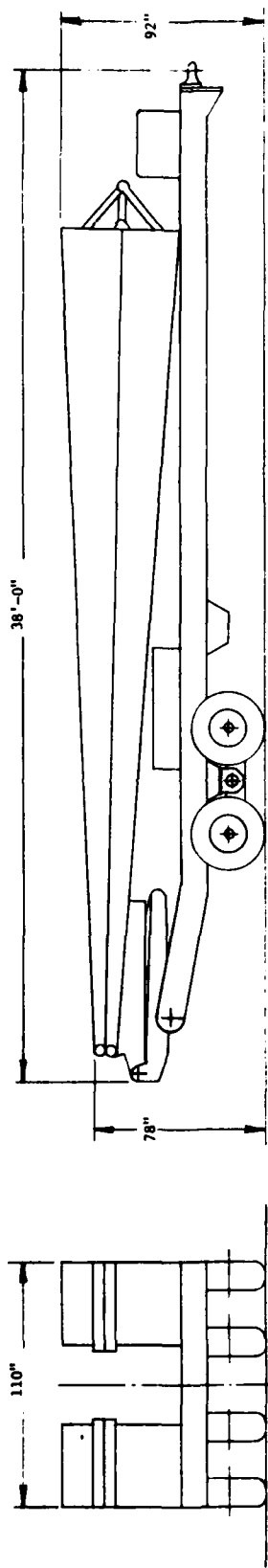
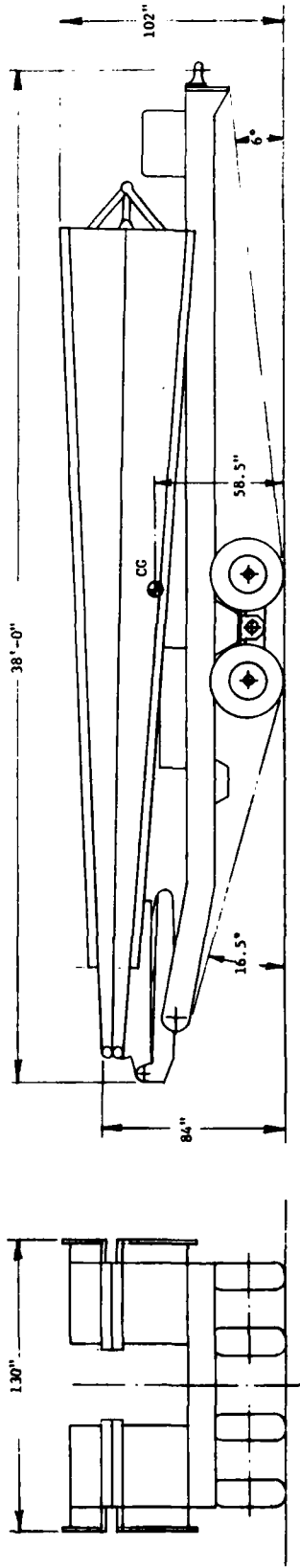

FIGURE 13 TASK I SCISSORS BRIDGE, AIR AND GROUND TRANSPORT CONFIGURATIONS



Air Transport Configuration



Ground Transport Configuration

FIGURE 14 TASK IIA SCISSORS BRIDGE, AIR AND GROUND TRANSPORT CONFIGURATIONS

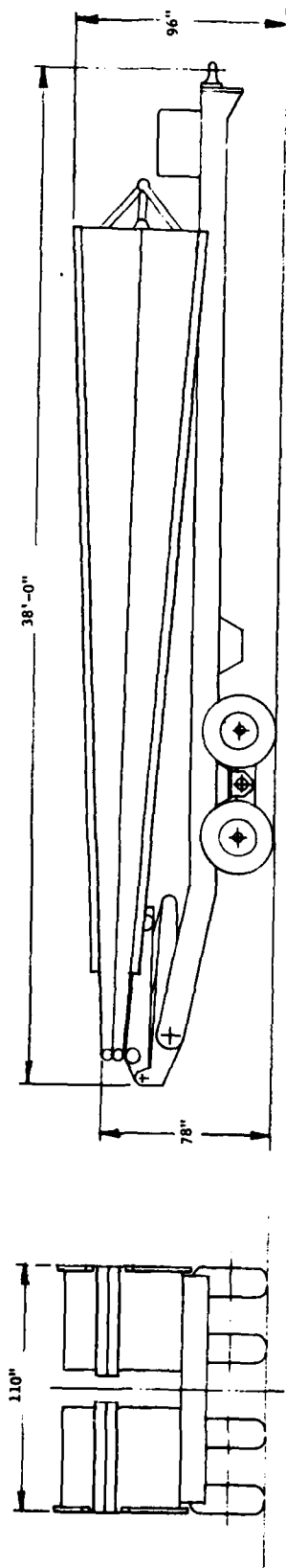

Air Transport Configuration

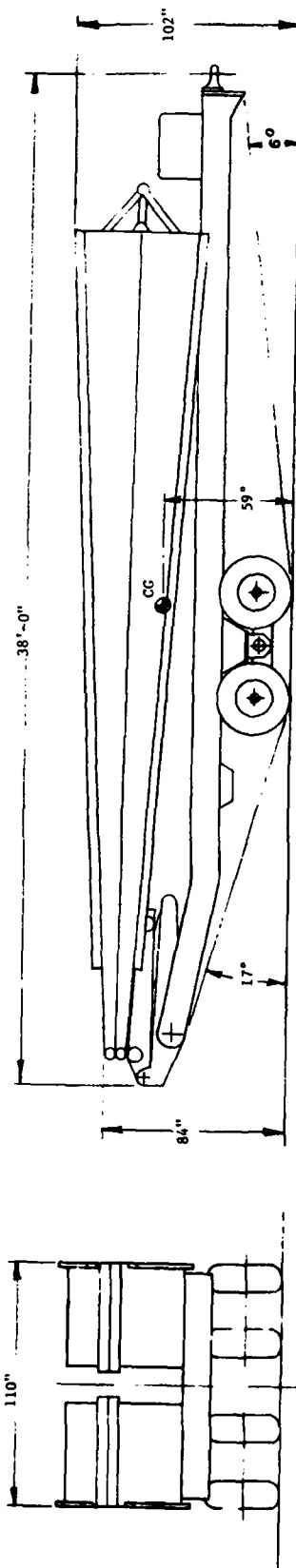

Ground Transport Configuration

FIGURE 15 TASK IIB SCISSORS BRIDGE, AIR AND GROUND TRANSPORT CONFIGURATIONS

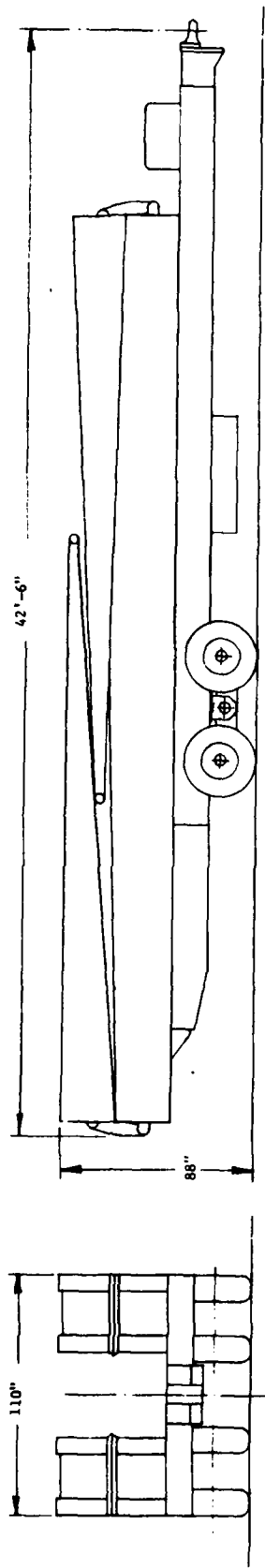

Air Transport Configuration

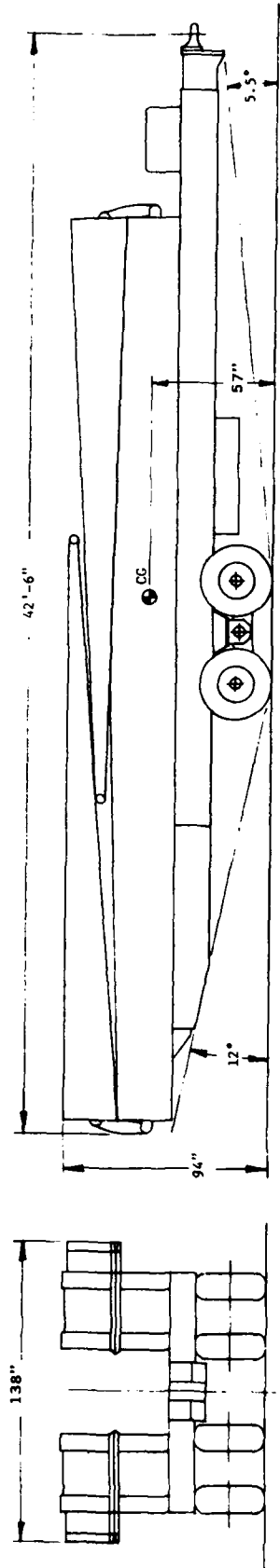

Ground Transport Configuration

FIGURE 16 TASK IIIA FLIP-LAUNCH BRIDGE, AIR AND GROUND TRANSPORT CONFIGURATIONS

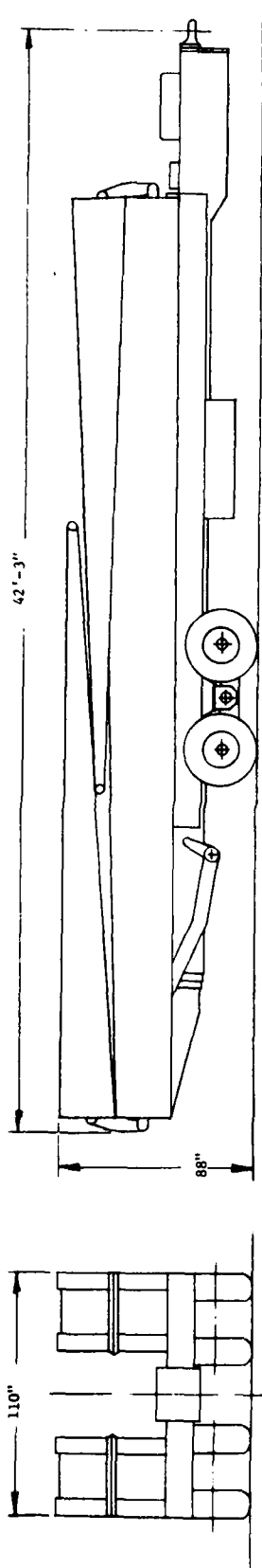

Air Transport Configuration

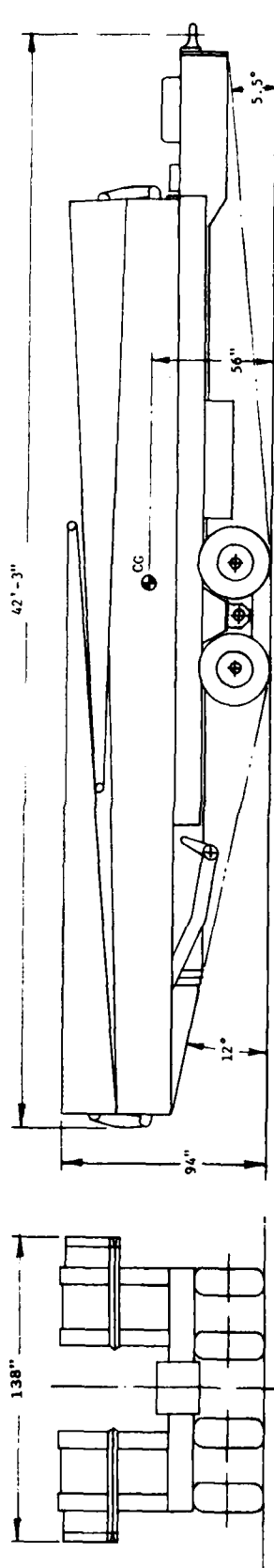

Ground Transport Configuration

FIGURE 17 TASK III B BEAM-LAUNCH BRIDGE, AIR AND GROUND TRANSPORT CONFIGURATIONS

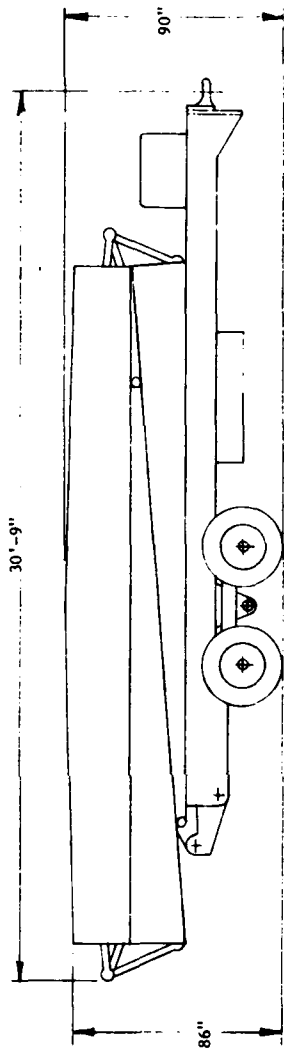

Air Transport Configuration

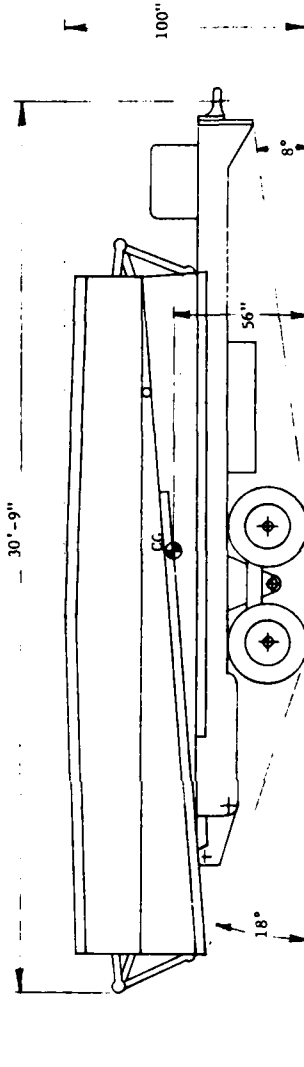

Ground Transport Configuration

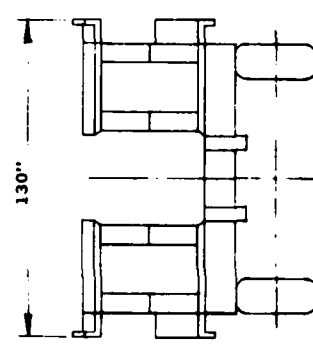
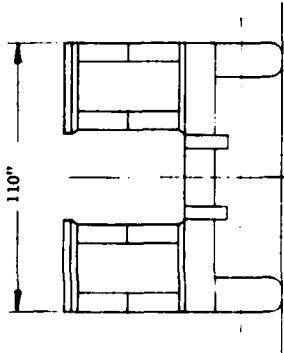
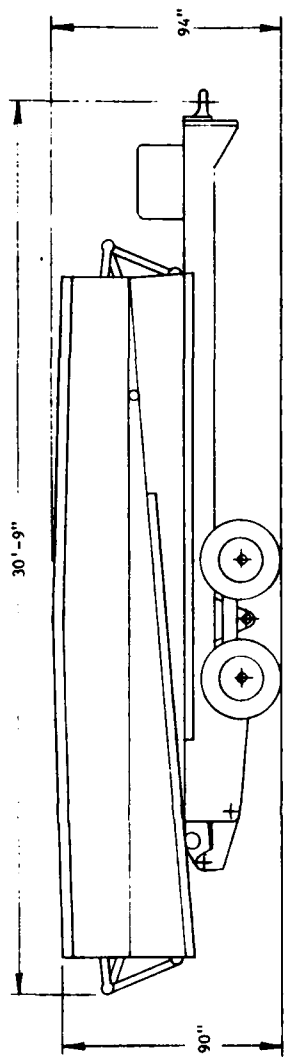
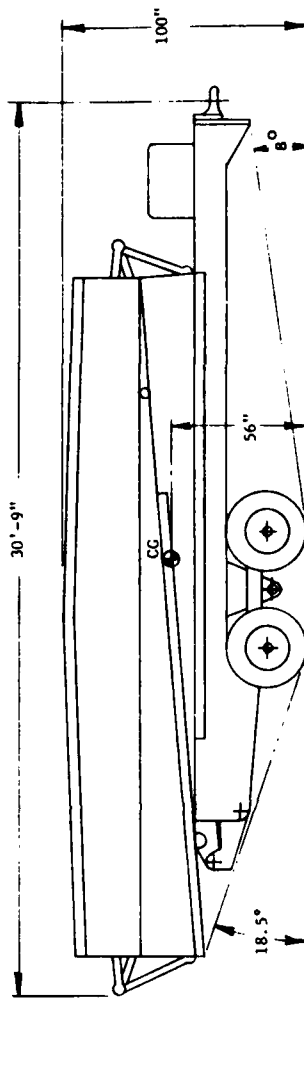

FIGURE 18 TASK III C1 DOUBLE-SCISSORS BRIDGE, AIR AND GROUND TRANSPORT CONFIGURATIONS



Air Transport Configuration



Ground Transport Configuration

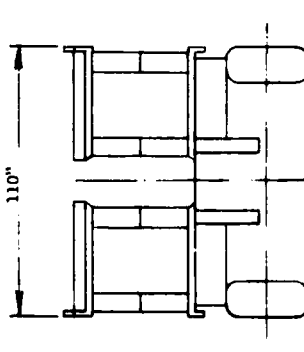
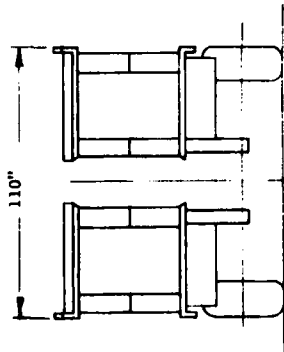

FIGURE 19 TASK IIIC2 DOUBLE-SCISSORS BRIDGE, AIR AND GROUND TRANSPORT CONFIGURATIONS

TABLE 13. SYSTEM, LOGISTICAL CHARACTERISTICS, AIR TRANSPORT

Characteristic	Task I Scissors	Task IIA Scissors	Task IIB Scissors	Task IIIA Flip-Launch	Task IIIB Beam-Launch	Task IIIC1 Double Scissors	Task IIIC2 Double Scissors
Air Transport (C-141):							
Weight, Estimated, With 8-Wheel, 12.00-16.5 Suspension	19,900 lb	20,100 lb	20,800 lb	23,900 lb	24,700 lb	Not Feasible	Not Feasible
Weight, Estimated With 4-Wheel, 14.00-17.5 Suspension	17,700 lb	17,900 lb	18,600 lb	Not Feasible	Not Feasible	17,700 lb	18,400 lb
Meets C-141 Load Limitations	Yes	Yes	Yes	Yes	Yes	Yes	Yes
Overall Length	38 ft, 4 in.	38 ft, 0 in.	38 ft, 0 in.	42 ft, 6 in.	42 ft, 3 in.	30 ft, 9 in.	30 ft, 9 in.
Overall Width	110 in.	110 in.	110 in.	110 in.	110 in.	110 in.	110 in.
Overall Height	92 in.	92 in.	96 in.	88 in.	88 in.	90 in.	94 in.
Height at Rear	84 in.	78 in.	78 in.	88 in.	88 in.	86 in.	90 in.
Required Lunette Height Adjustment During Rearward Loading ^a	None	None	None	32 in.	32 in.	30 in.	36 in.
Loading Difficulty (Forward) ^b	2	2	2	2	2	1	1
Loading Difficulty (Rearward) ^b	1	1	1	3	3	2	2
Loading Equipment	Tow Vehicle	Tow Vehicle	Tow Vehicle	Tow Vehicle	Tow Vehicle	Tow Vehicle	Tow Vehicle
Estimated Load Preparation Time (Forward Loading)	15 min, 2 Men or 30 min, 1 Man	15 min, 2 Men or 30 min, 1 Man	5 min, 1 Man	30 min, 2 Men	30 min, 2 Men	15 min, 2 Men or 30 min, 1 Man	5 min, 1 Man
Preparation Requirements (Forward Loading)	Remove & Stow Deck Extensions	Remove & Stow Deck Extensions	Narrow Bridge	Move Suspension Remove & Stow Deck Extensions	Move Suspension Remove & Stow Deck Extensions	Remove & Stow Deck Extensions	Narrow Bridge
Estimated Load Preparation Time (Rearward Loading)	25 min Two Men	25 min Two Men	15 min Two Men	30 min Two Men	30 min Two Men	25 min Two Men	15 min Two Men
Preparation Requirements (Rearward Loading)	Move Suspension Remove & Stow Deck Extensions	Move Suspension Remove & Stow Deck Extensions	Move Suspension Narrow Bridge	Move Suspension Remove & Stow Deck Extensions	Move Suspension Remove & Stow Deck Extensions	Move Suspension Remove & Stow Deck Extensions	Move Suspension Narrow Bridge
Preparation Equipment	On-Board Equipment & Hand Tools	On-Board Equipment & Hand Tools	On-Board Equipment & Hand Tools	On-Board Equipment & Hand Tools	On-Board Equipment & Hand Tools	On-Board Equipment & Hand Tools	On-Board Equipment & Hand Tools

^aIn all concepts, no lunette height adjustment is required during forward loading.

^bNumerical ratings are comparative; lower numbers indicate better ratings.

TABLE 14. ESTIMATED WEIGHTS
(Pounds)

	<u>Bridge</u>	<u>Launch Mechanism</u>	<u>Hydraulic Power Unit</u>	<u>Trailer</u>	<u>Total System</u>
Task I Scissors Bridge	7,000	2,200	2,000	8,700 ^a	19,900
Task IIA Scissors Bridge	7,000	2,400	2,000	8,700 ^a	20,100
Task IIB Scissors Bridge	7,100	3,000	2,000	8,700 ^a	20,800
Task IIIA Flip-Launch Bridge	9,500	2,700	2,000	9,700 ^a	23,900
Task IIIB Beam-Launch Bridge	9,200	4,800	2,000	8,700 ^a	24,700
Task IIIC1 Double Scissors Bridge	7,500	2,200	2,000	6,000 ^b	17,700
Task IIIC2 Double Scissors Bridge	7,600	2,800	2,000	6,000 ^b	18,400

^aTrailer weight is based on 8-wheel suspension.
4-wheel suspension would be approximately 2200 lb lighter.

^bTrailer weight is based on 4-wheel suspension.

Overall Length: This measurement is the overall length with the bridge stowed on the trailer.

Overall Width: This overall width of the bridge and trailer is with the bridge in the air transport configuration.

Overall Height: This overall height of the bridge and trailer is with the trailer suspension in the air transport position, taken at the highest point of the bridge. The highest point of the scissors bridges is at the front of the trailer. The highest points of the flip-launch bridges are at the front and rear. The highest point of the double-scissors bridges is at the center of the bridge, but front and rear heights are only 4 in. less.

Height at Rear: This height at the rear of the bridge provides a measure of how difficult it is to load the trailer into the aircraft in the rearward direction. The critical position is at the top of the ramp: the greater the rear height of the bridge, the greater the problem of interference with the top of the cargo space.

Required Lunette Height Adjustment During Rearward Loading: While the trailer is being pushed up the ramp by the tow vehicle, the lunette must be adjusted vertically this distance from its normal tow position to avoid encroaching on the 6 in. clearance required between the top rear of the bridge and the top of the cargo space. The Task I, IIA, and IIB scissors-bridge concepts can be loaded without adjustment of the lunette, although the Task I bridge encroaches into the 6 in. clearance zone by about 2 in.

Loading Difficulty (Forward): In all concepts, the tow vehicle can be driven forward up the ramp, towing the trailer, without any adjustments being required during the loading procedure. This procedure should be slightly less difficult in the double-scissors bridge concepts because they have greater clearance between the rear end of the bridge and the ground when the trailer wheels are just starting up the ramp.

Loading Difficulty (Rearward): This assessment of the overall difficulty of loading the trailer in the rearward direction in the C-141 aircraft takes into account the overall dimensions and configuration of each concept. Even though considerably longer than the double-scissors bridge concepts, the scissors bridges should be easier to load in the rearward direction because of their lesser rear height.

Loading Equipment: In all concepts, loading the trailer in the aircraft by means of only the tow vehicle should be possible.

Estimated Load Preparation Time (Forward Loading): This estimated time is required to prepare the bridge and trailer for forward loading in the C-141. In the Task IIIA and IIIB concepts, the running gear must be moved to the air transport position, which is considered a 2-man task.

Preparation Requirements (Forward Loading): These operations must be performed to prepare the bridge and trailer for forward loading in the C-141.

Estimated Load Preparation Time (Rearward Loading): This is an estimate of the time required for two men to prepare the bridge and trailer for rearward loading in the C-141. Moving the suspension is considered a 2-man task.

Preparation Requirements (Rearward Loading): These operations must be performed to prepare the bridge and trailer for rearward loading in the C-141.

Preparation Equipment: Only on-board equipment (front jackpost and rear outriggers) and handtools are needed to prepare the bridge and trailer for air transport. The hydraulic power supply must be powered up to operate the outriggers.

13.1.4 System, Logistical Characteristics, Ground Transport

Figures 13 through 19 illustrate the ground transport configuration of all concepts. The logistical characteristics for ground transport are presented in Table 15 and are discussed below:

Weight, Estimated, with 8-Wheel, 12.00-16.50 Tire Suspension: A breakdown of the estimated weights was shown in Table 14. This suspension is not feasible for the double-scissors bridge concepts because of insufficient space.

Weight, Estimated, with 4-Wheel, 14.00-17.50 Tire Suspension: The 4-wheel suspension reduces system weights by 2200 lb. The 4-wheel suspension is not considered feasible for the flip-launch and beam-launch bridges because of the greater weights and comparatively poor cross-country mobility characteristics of those concepts.

Overall Length: This measurement is the overall length with the bridge stowed on the trailer.

Overall Width: This measurement is the overall width of the bridge. The Task IIB and IIIC2 concept bridges can be transported to the launch at either a 110 in. or 130 in. width. The width of the trailer is 110 in. for all concepts.

Overall Height: This measurement is the overall height of the bridge and trailer taken at the highest point of the bridge, with the trailer suspension in the ground transport position.

C.G. Height: This measurement is the estimated height of the center of gravity of the entire system above the ground, with the suspension in the ground transport position. A lower center of gravity aids in negotiating lateral slopes in cross-country travel.

TABLE 15. SYSTEM, LOGISTICAL CHARACTERISTICS, GROUND TRANSPORT

Characteristic	Task I Scissors	Task IIA Scissors	Task IIB Scissors	Task IIIA Flip-Launch	Task IIIB Beam-Launch	Task IIIC Double Scissors	Task IIIC2 Double Scissors
Ground Transport:							
Weight, Estimated, W. 4-Wheel, 14.00-17.5 Suspension	19,900 lb	20,100 lb	20,800 lb	23,900 lb	24,700 lb	19,900 lb	20,600 lb
Weight, Estimated W. 8-Wheel, 14.00-17.5 Suspension	17,700 lb	17,900 lb	18,600 lb	Not Feasible	Not Feasible	17,700 lb	18,400 lb
Overall Length	38 ft, 4 in.	38 ft, 0 in.	38 ft, 0 in.	42 ft, 6 in.	42 ft, 3 in.	30 ft, 9 in.	30 ft, 9 in.
Overall Width	130 in.	130 in.	110 in.	138 in.	138 in.	130 in.	110 in.
Overall Height	102 in.	102 in.	102 in.	94 in.	94 in.	100 in.	100 in.
C. G. Height	60 in.	58.5 in.	59 in.	57 in.	56 in.	56 in.	56 in.
Approach Angle	6.5°	6°	6°	5.5°	5.5°	8°	8°
Departure Angle	13°	16.5°	17°	12°	12°	18°	18.5°
Overall Highway Mobility ^a	5	4	3	6	7	2	1
	All Exceed Length and Width Limitations in MIL-C-52437B (ME)						
Overall Cross- Country Mobility ^a	2	2	2	3	3	1	1
Positioning for Launch & Retrieval ^a	2	2	2	3	3	1	1
Est. Preparation Time after Unloading from AC (Forward Loading)	15 min, 2 Men or 30 min, 1 Man	15 min, 2 Men or 30 min, 1 Man	5 min, 1 Man	30 min, 2 Men	30 min, 2 Men	15 min, 2 Men or 30 min, 1 Man	5 min, 1 Man
Preparation Requirements (Forward Loading)	Install Deck Extensions	Install Deck Extensions	Widen Bridge (Optional)	Move Suspension Install Deck Extensions	Move Suspension Install Deck Extensions	Install Deck Extensions	Widen Bridge (Optional)
Est. Preparation Time after Unloading from AC (Rearward Loading)	25 min, 2 Men	25 min, 2 Men	15 min, 2 Men	30 min, 2 Men	30 min, 2 Men	25 min, 2 Men	15 min, 2 Men
Preparation Requirements (Rearward Loading)	Move Suspension Install Deck Extensions	Move Suspension Install Deck Extensions	Move Suspension Widen Bridge (Optional)	Move Suspension Install Deck Extensions	Move Suspension Install Deck Extensions	Move Suspension Install Deck Extensions	Move Suspension Widen Bridge (Optional)
Preparation Equipment	On-Board Equip- ment & Hand Tools	On-Board Equip- ment & Hand Tools	On-Board Equip- ment & Hand Tools	On-Board Equip- ment & Hand Tools	On-Board Equip- ment & Hand Tools	On-Board Equip- ment & Hand Tools	On-Board Equip- ment & Hand Tools

^aNumerical ratings are comparative; lower numbers indicate better ratings.

Approach Angle: Figures 13 through 19 indicate this angle for the seven concepts. The angles for all concepts are smaller than for other typical military trailers intended for cross-country travel (see Figures 2 and 4).

Departure Angle: Figures 13 through 19 indicate this angle for the seven concepts. The angles for all concepts are smaller than for other typical military trailers intended for cross-country travel. The double-scissors concepts have the largest departure angles. However, in the Task IIA and IIB scissors-bridge concepts, the design can be modified to increase the rear height by about 4 in. This modification would reduce the aircraft loading clearance to exactly the required 6 in. and would increase the ground transport departure angles to be approximately equal to those of the double-scissors concepts.

Overall Highway Mobility: This rank is a comparative assessment of the overall highway travel characteristics of the concepts. The double-scissors bridge concepts receive the best rating because of their shorter length, but all concepts exceed the length and width limitations of MIL-C-52437B(ME), CCE version.

Overall Cross-Country Mobility: This rank is a comparative assessment of the overall cross-country mobility characteristics of the concepts. The double-scissors bridge concepts receive the best rating because of shorter length, lower center of gravity, and larger approach angles, but none of the concepts has cross-country mobility characteristics equal to typical military-trailer-borne equipment.

Positioning for Launch and Retrieval: This rank is a comparative assessment of the overall ease of positioning the trailer for launch or retrieval. Overall length is the principal criterion.

Estimated Preparation Time After Unloading From Aircraft (Forward Loading): This estimate time is required to prepare the bridge and trailer for towing to the launch site after unloading them from the forward-loaded position in the C-141. In the Task IIIA and IIIB concepts, the running gear must be moved to the ground transport position, which is considered a 2-man task. The estimated times for the Task IIB and IIIC2 concepts include widening the bridge to deployed width, although this can be done on the way to or at the launch site if desired.

Preparation Requirements (Forward Loading): These operations must be performed to prepare the bridge and trailer for towing to the launch site after unloading them from the forward-loaded position in the C-141.

Estimated Preparation Time after Unloading from Aircraft (Rearward Loading): This estimated time is for two men to prepare the bridge and trailer for towing to the launch site after unloading them from the rearward-loaded position in the C-141. Moving the suspension is considered a 2-man task. The estimated times for the Task IIB and IIC2 concepts include widening of the bridge to deployed width, although this can be done on the way to or at the launch site if desired.

Preparation Requirements (Rearward Loading): These operations must be performed to prepare the bridge and trailer for towing to the launch site after unloading them from the rearward-loaded position in the C-141.

Preparation Equipment: Only on-board equipment (front jackpost and rear outriggers) and handtools are needed to prepare the bridge and trailer for ground transport. The hydraulic power supply must be powered up to operate the outriggers (it is desirable to check this out operationally before proceeding to the launch site). In the Task IIB and IIIC2 concepts, the bridge must be widened under power.

13.1.5 System, Operational Characteristics, Launch

Table 16 presents the operational characteristics for system launch. These characteristics are discussed below:

Launch Method: Self-explanatory.

Launch Mechanism: Self-explanatory.

Estimated Launch Time after Positioning Trailer: These estimated launch times take into account the mass of the bridge, the difficulty of controlling each step, and the capacity of the hydraulic power supply. The estimated launch times for the flip-launch and beam-launch bridges exceed the 5 minute maximum time permitted by the draft ROC.

Manning: The tow vehicle driver and the launch operator can launch the bridges, with assistance in positioning the trailer from an observer in another vehicle. In an emergency, the bridges could probably be launched successfully by the tow vehicle driver, provided he is trained in the operation of the launch mechanism.

Skill Level: No new or special Military Occupation Specialty (MOS) identifier is required to support the operational capability of any of the concepts.

Launch Procedure Complexity: This comparative rating of the complexity of the launch procedure takes into account the number and relative difficulty of the functions required.

Number of Control Functions: The control functions are identified in Table 17.

Operator Exposure Outside Vehicle: The only concept requiring personnel to leave the tow vehicle during launch is the beam-launch bridge, which requires that the trailer be unhitched from and rehitched to the tow vehicle.

TABLE 16. SYSTEM, OPERATIONAL CHARACTERISTICS, LAUNCH

Characteristic	Task I Scissors	Task IIA Scissors	Task IIB Scissors	Task IIIA Flip-Launch	Task IIIB Beam-Launch	Task IIIC1 Double Scissors	Task IIIC2 Double Scissors
<u>Launch:</u>							
Launch Method	Overhead Cantilever	Overhead Cantilever	Overhead Cantilever	Cantilever	Traverse Beam (in trailer)	Overhead Cantilever	Overhead Cantilever
Launch Mechanism	Boom & Tongue Min Modification of Army Design	Boom & Tongue Modified	Boom & Tongue Modified	Rack & Pinion Lowering Arm	Telescoping Beam Chain Drive Lowering Arm	Boom & Tongue Modified	Boom & Tongue Modified
Estimated Launch Time after Positioning Trailer	3.5 min	3.5 min	3.7 min ^a 4.2 min ^b	6.0 min	8.2 min	4.5 min	4.7 min ^a 5.2 min ^b
Manning							
Skill Level							
Launch Procedure Complexity	Low	Low	Low	High	High	Medium	Medium
No. of Control Functions	9	9	9	12	11	10	10
Operator Exposure Outside Vehicle	None	None	None	None	Unhitch & Rehit Trailer	None	None
Launch in Poor Visibility (Smoke)	Good Feasibility	Good Feasibility	Good Feasibility	More Difficult	More Difficult	Good Feasibility	Good Feasibility
Vulnerability to Small Arms Fire	Less Vulnerable	Less Vulnerable	Less Vulnerable	Sliding Mechanisms Subject to Jamming	Sliding Mechanisms Subject to Jamming	Less Vulnerable	Less Vulnerable
Vulnerability to Artillery Fire	Less Vulnerable	Less Vulnerable	Less Vulnerable	Sliding Mechanisms Subject to Jamming	Sliding Mechanisms Subject to Jamming	Less Vulnerable	Less Vulnerable
Vulnerability to NBC				No Significant Difference Between Systems.			

Driver, Operator, and Observer in other Vehicle, in all Cases.

No New Mos. Requirements, in all Cases.

^a Bridge widened before arrival at launch site.

^b Bridge widened at launch site.

TABLE 16 (CONTINUED)

Characteristic	Task I	Task IIB	Task IIB	Task IIIA	Task IIIE	Task IIIC	Task IIIC2
	Scissors	Scissors	Scissors	Flip-Launch	Beam-Launch	Double-Scissors	Double-Scissors
Length on Bank not Including Tow Vehicle	35 ft	35 ft	35 ft	50 ft	32 ft	23 ft	23 ft
Width	130 in.	130 in.	130 in.	130 in.	130 in.	130 in.	130 in.
Maximum Height During Launch	34 ft	34 ft	34 ft	28 ft	28 ft	25 ft	25 ft
Static Upward Force on Tow Pintle	3,500 lb	3,500 lb	3,600 lb	8,300 lb	0	8,600 lb	8,700 lb
Static Force on Level Bank at Fulcrum	18,200 lb	18,400 lb	19,200 lb	32,200 lb	20,900 lb	23,300 lb	24,100 lb
Max. Lateral Wind Moment at 2.88 lb/sq ft	5,130 lb ft	5,130 lb ft	5,130 lb ft	-	-	4,920 lb ft	4,920 lb ft
Max. Moment Due to 10% Lateral Slope	13,100 lb ft	13,100 lb ft	13,300 lb ft	-	-	18,400 lb ft	13,400 lb ft
Equivalent Fulcrum Force Including Max. Lateral Wind & Slope	22,200 lb	22,400 lb	23,200 lb	32,200 lb	20,900 lb	29,400 lb	30,200 lb
Required Fulcrum Area at 15.95 lb/sq in.	1,390 sq in.	1,400 sq in.	1,450 sq in.	2,020 sq in.	1,310 sq in.	1,840 sq in.	1,890 sq in.
Effect of 10% Longitudinal Slope	Not Significant	Not Significant	Not Significant	Combination of Slope Toward Gap and Higher Far Bank Makes Launch Difficult	Combination of Slope Toward Gap and Higher Far Bank Makes Launch Difficult	Not Significant	Not Significant
Launching to a Higher Far Bank	No Problem	No Problem	No Problem	Not Feasible	Not Feasible	No Problem	No Problem
Safety	All Systems Equally Safe -- Operators not near Bridge or Launch Mechanism.						
Ability To Launch Manually in an Emergency	Not Feasible	Not Feasible	Not Feasible	Not Feasible	May be Possible under some Conditions	Not Feasible	Not Feasible

TABLE 17. CONTROL FUNCTIONS

Function	Task-Concept							
	Actuator	I	IIA	IIB	IIIA	IIIB	IIIC1	IIIC2
Engine Glow Plugs (On-Off)		1	1	1	1	1	1	1
Engine Starter (PB)		1	1	1	1	1	1	1
Deploy Outriggers (Up-Down-Off)		1	1	1	1	1	1	1
Outrigger, Left (Up-Down-Off)	Cylinders	1	1	1	1	1	1	1
Outrigger, Right (Up-Down-Off)	Cylinder	1	1	1	1	1	1	1
Launch Boom (Raise-Lower-Off)	Cylinders	1	1	1	1	1	1	1
Launch Tongue (Raise-Lower-Off)	Cylinders	1	1	1	1	1	1	1
Lock Pins (Extend-Retract-Off)	Cylinder	1	1	1	1	1	1	1
Pickup Pins (Extend-Retract-Off)	Hyd. Motor	1	1	1	1	1	1	1
Folding Linkages (Fold-Unfold-Off)	Cylinders	1	1	1	2	2	2	2
Engage Folding Cylinders (Up-Down-Off)	Cylinders				1	1	1	
Bridge Lowering Arms (Raise-Lower-Off)	Cylinders				1	1	1	
Bridge Launching Drive (Fwd-Rev-Off)	Hyd. Motor				1	1	1	
Rail Lock Pins (In-Out-Off)	Cylinders				1	1	1	
Lunette Height Adjust (Up-Down-Off)	Hyd. Motor				1	1	1	
Telescoping Beam Drive (Fwd-Rev-Off)	Hyd. Motor					1		
Total		9	9	9	12	11	10	10

Launch in Poor Visibility (Smoke): This is an assessment of the relative difficulty of launching the bridge in poor visibility such as under cover of smoke. The scissors and double-scissors bridge concepts are considered easier to launch under such conditions because of their overhead launching method, in which visibility of the far bank should be less important than in the cantilever launch procedures used in the flip-launch and beam-launch bridge concepts.

Vulnerability to Small Arms Fire: The launch mechanisms for the scissors and double-scissors bridges, consisting primarily of pivoted arms, are considered less vulnerable to jamming from the effects of small arms fire than are the sliding mechanisms used in the flip-launch and beam-launch bridge concepts.

Vulnerability to Artillery Fire: Same comments as above.

Vulnerability to NBC: No significant difference between the concepts is apparent.

Length on Bank, not including Tow Vehicle: This measurement is an indication of the extent of level or uniformly sloping space that must be available on the bank to permit successful launch.

Width: This measurement is the same for all concepts.

Maximum Height during Launch: This measurement is the maximum height above the ground reached by any part of the bridge during launch.

Static Upward Force on Tow Pintle: This force is required to counterbalance the system during the cantilever launch and, in general, is directly proportional to the bridge weight and length and inversely proportional to trailer length. The beam-launch

bridge requires no external counterbalancing because the light traverse beam can be counterbalanced by the trailer alone.

Static Force on Level Bank at Fulcrum: This force is the sum of system weight and pintle force.

Maximum Lateral Wind Moment at 2.88 Pounds per Square Foot: This wind pressure is equivalent to a 28.8 knot wind during launch as specified in the Trilateral Design and Test Code. This moment is calculated at the point of maximum exposure of the bridge. In all cases, its effect is relatively small compared to the dead weight loads and is significant only in the scissors and double-scissors concepts.

Maximum Moment due to the 10% Lateral Slope: The 10% lateral slope is specified in the draft ROC. The moment shown in Table 17 is calculated based on the height of the center of gravity of the bridge above the ground.

Equivalent Fulcrum Force, including Maximum Lateral Wind and Slope: This equivalent force is calculated by converting the moments due to wind and lateral slope to equivalent forces and adding them to the level bank fulcrum loads.

Required Fulcrum Area at 15.95 Pounds per Square Inch: This fulcrum or outrigger area, required to support the system on the bank during launch, is based on 15.95 lb/sq. in. in maximum bearing pressure as specified in the Trilateral Design and Test Code.

Effect of 10% Longitudinal Slope: This condition should cause no problems with the overhead cantilever launch bridges, but in combination with a higher far bank, makes launching of the flip-launch and beam-launch bridges more difficult.

Launching to a Higher Far Bank: This should not be a problem with the overhead cantilever launch bridges, but in combination with a slope toward the gap, can make launching of the flip-launch and beam-launch bridges more difficult.

Safety: Because personnel are not required to be near the bridge during launch in any of the concepts, all systems appear equally safe with respect to possible injury from launching accidents.

Ability to Launch Manually in an Emergency: Launching by manual methods in an emergency does not appear to be feasible in any case except the beam-launch concept. In that case, the forces required to extend the traverse beam and roll the bridge across it may be low enough so that the bridge could conceivably be launched by manual methods under favorable conditions, i.e., banks of equal height. However, a crane would be needed to extend the ramps if the on-board unfolding system were not operating.

13.1.6 System, Operational Characteristics, Retrieval

Table 18 presents operational characteristics for system retrieval. These characteristics are discussed below:

Estimated Retrieval Time after Positioning Trailer: These estimated times take into account the mass of the bridge, the difficulty of controlling each step, and the capacity of the hydraulic power supply.

Manning: For all concepts, bridge retrieval can be accomplished by the tow vehicle driver and the launch operator.

TABLE 18. SYSTEM, OPERATIONAL CHARACTERISTICS, RETRIEVAL

Characteristic	Task I Scissors	Task IIA Scissors	Task IIB Scissors	Task IIIA Flip-Launch	Task IIIB Beam-Launch	Task IIIC Double Scissors	Task IIIC2 Double Scissors
<u>Retrieval:</u>							
Estimated Retrieval Time after Positioning Trailer	5.5 min	5.5 min ^a 6.4 min	5.7 min ^a 6.5 min ^b	5.3 min	8.5 min	6.5 min	6.7 min
Manning	Driver and Operator plus Observer in all Cases.						
Operator Exposure Outside Vehicle	Operator must Leave Vehicle to Engage Launch Mechanism with Bridge, in all Cases.						
Retrieval from Either End	Yes	Yes	Yes	Yes	Yes	Yes	Yes
Retrieval Feasible by any Vehicle Capable of Launching Bridge	Yes	Yes	Yes	Yes	Yes	Yes	Yes

^a Retrieval from launch end.

^b Retrieval from opposite end.

Operator Exposure outside Vehicle: In all concepts, the operator must leave the tow vehicle to position the launch mechanism and engage it with the pick-up points of the bridge.

Retrieval from Either End: In all concepts, the bridge can be retrieved either from the launch end or the opposite end. However, in the Task IIA and IIB concepts, retrieval from the opposite end will take a little longer because of the need to reposition the folding mechanism of the bridge.

Retrieval Feasible by any Vehicle capable of Launching the Bridge:
Self explanatory.

13.1.7 System, RAM Characteristics

Table 19 presents the RAM characteristics of the system. These characteristics are discussed below:

Reliability: The operational reliability of the scissors and double-scissors bridge concepts is expected to be superior to that of the flip-launch and beam-launch bridge concepts because of the comparative simplicity of the launch system and mechanism and because all elements of the launch mechanism fully engage with the interface points on the bridge and stay engaged until the bridge is launched across the gap and set down on the far bank. In addition, wide usage of the overhead cantilever launch method has demonstrated that it is feasible and reliable.

Availability: The operational availability of the flip-launch and beam-launch bridge systems is expected to be lower than that of the other concepts because of the greater complexity of the launch mechanisms.

TABLE 19. SYSTEM, RAM CHARACTERISTICS

Characteristic	Task I Scissors	Task IIA Scissors	Task IIB Scissors	Task IIIA Flip-Launch	Task IIIB Beam-Launch	Task IIIC1 Double Scissors	Task IIIC2 Double Scissors
Reliability	Good--Launch Mechanism Locked to Bridge During Launch. Proven System.	Good--Launch Mechanism Locked to Bridge During Launch. Proven System.	Good--Launch Mechanism Locked to Bridge During Launch. Proven System.	Heavily Loaded Moving Interfaces between Launch Mechanism & Bridge Launch Mechanism is Complex.	Moving Interfaces Between Launch Mechanism & Bridge Launch Mechanism is very Complex.	Good--Launch Mechanism Locked to Bridge During Launch. Proven System.	Good--Launch Mechanism Locked to Bridge During Launch. Proven System.
Availability	Good	Good	Good	More Down Time Due to Greater Complexity. Relatively Complex System. Poor Accessibility When Bridge is on Trailer.	More Down Time Due to Greater Complexity. Relatively Complex System. Poor Accessibility.	Good	Good
Maintainability	Conventional Launch Mechanism. Relatively Simple. Good Accessibility.	Conventional Launch Mechanism. Relatively Simple. Good Accessibility.	Conventional Launch Mechanism. Relatively Simple. Good Accessibility.	Conventional Launch Mechanism. Relatively Simple. Good Accessibility.	Conventional Launch Mechanism. Relatively Simple. Good Accessibility.	Conventional Launch Mechanism. Relatively Simple. Good Accessibility.	Conventional Launch Mechanism. Relatively Simple. Good Accessibility.
Tools	All Systems Can Be Designed To Avoid Need for Special Tools except Repair Kits.						
Lubricants	Standard Lubricants Should Be Adequate in all Cases.						
Decomamination	Good Accessibility.	Good Accessibility.	Good Accessibility.	Accessibility not as Good.	Accessibility not as Good.	Good Accessibility.	Good Accessibility.

Maintainability: The scissors and double-scissors bridge systems are expected to be easily maintained because the launch mechanism is conventional and relatively simple. It is also easily accessible even when the bridge is on the trailer, since the launch mechanism and hydraulic power supply are located at the extreme ends of the trailer. The flip-launch and beam-launch bridge systems utilize more complex launch mechanisms, and some elements of the launch mechanisms are located in places where there is comparatively poor accessibility, particularly when the bridge is on the trailer.

Tools: Design of all systems should be possible so that no special tools will be needed other than repair kits.

Lubricants: None of the concepts should require the use of nonstandard lubricants.

Decontamination: The scissors and double-scissors bridge systems have good accessibility for decontamination procedures. The flip-launch and beam-launch systems are not as good in this respect, because they both have long telescoping members.

13.1.8 System, General Characteristics

Table 20 presents the general characteristics of the system. These characteristics are discussed below:

Life: None of the systems appears to have inherent characteristics which would prevent it from being designed for the required life of 5000 Military Load Class 30 (MLC) crossings.

TABLE 20. SYSTEM, GENERAL CHARACTERISTICS

Characteristic	Task I Scissors	Task IIA Scissors	Task IIB Scissors	Task IIIA Flip-Launch	Task IIIB Beam-Launch	Task IIIC1 Double Scissors	Task IIIC2 Double Scissors
Life	All Systems Capable of 5000 MLC 30 crossings.						
Cost for Design and Construction of Two Prototype Systems (Estimated)	\$680,000	\$740,000	\$800,000	\$1,135,000	\$1,250,000	\$835,000	\$930,000
Development Risk	Very Low	Low	Low	High	Very High	Low	Low

Cost for Design and Construction of Two Prototype Systems (Estimated): A breakdown and explanation of the cost estimates are provided in Chapter 12.

Development Risk: The scissors bridge concepts, particularly the Task I concept, are based on widely used principles and an existing prototype design. The double-scissors bridge concept has been demonstrated in prototype form. The flip-launch and beam-launch concepts are new, although some elements of each were used in the bridging for the 80's System.

13.2 Trade-Off Analysis

13.2.1 Summary

The preferred design concept is the Task IIB single-fold scissors bridge with folding cross-bracing that permits narrowing the bridge for air transport. This concept's launch mechanism is capable of narrowing and widening the bridge and performing all launch and retrieval functions, including actuating the bridge folding linkage. However, in view of the relatively poor cross-country mobility characteristics of all concepts, it is possible that cross-country mobility may become an overriding consideration. If so, the Task IIIC2 double-scissors bridge system would become the preferred concept. The selection procedure and rationale, based on the information contained in the previous tables in this chapter, are discussed below.

13.2.2 Comparison of Task IIIA Flip-Launch Bridge to

Scissors-Bridge Concepts

The flip-launch bridge system has the following advantages over the scissors bridge concepts:

Bridge Characteristics: The flip-launch bridge has a 24 m span; however, the draft ROC requires only a 60 ft. (18.3 m) span.

Air Transport Characteristics: No advantages.

Ground Transport Characteristics: Slightly lower overall height.

Launch and Retrieval Characteristics:

- a. Lower launch profile.
- b. Less effect by wind and lateral slope.

RAM Characteristics: No advantages.

General Characteristics: No advantages.

The flip-launch bridge system has the following disadvantages with respect to the scissors bridge concepts:

Bridge Characteristics: The design is considerably more complex because of the need for bottom chord pinning mechanisms and the various features that interface with the launch mechanism.

Air Transport Characteristics:

- a. Greater total weight.
- b. Greater overall length.
- c. Greater height at the rear.
- d. A large adjustment of lunette height required during rearward-loading into the aircraft because of the combination of overall length and height at the rear.

The rearward loading operation for this concept would be comparatively difficult.

- e. Longer preparation time for loading, because the bridge is longer and therefore has more detachable deck extension sections.

Ground Transport Characteristics:

- a. Greater total weight.
- b. Greater overall length.
- c. Smaller angles of approach and departure.
- d. Comparatively poor overall cross-country mobility as a result of the combination of the above three characteristics.
- e. Longer preparation time after unloading from the aircraft because of the greater number of deck extension sections.

Launch and Retrieval Characteristics:

- a. Longer launch time (estimated time exceeds the 5 minute maximum launch time specified in the draft ROC).
- b. More complex launch and retrieval procedures.
- c. Greater vertical load on tow pintle.
- d. Greater fulcrum load on bank.
- e. More space on bank required.
- f. More difficult to launch in poor visibility.
- g. Greater difficulty in launching from a longitudinal slope to a higher far bank.
- h. Greater vulnerability of the launch mechanism to small arms and artillery fire.

RAM Characteristics:

- a. Probability of lower reliability because of the heavily loaded moving interfaces between launch mechanisms and

bridge during launch and retrieval, and the complexity of bridge and launch mechanism.

- b. Probability of lower availability because of the complexity of bridge and launch mechanism.
- c. Inferior maintainability because of the complexity of the bridge and launch mechanism and the poor accessibility to parts of the mechanism when the bridge is on the trailer.
- d. Accessibility for decontamination procedures not as good.

General Characteristics:

- a. Higher estimated cost to design and build prototype systems.
- b. Greater risk of not successfully completing development in time to meet schedule requirements.

It is apparent from the above that the shortcomings of the flip-launch bridge system in comparison with the scissors bridge systems outweigh its advantages. The flip-launch bridge is therefore eliminated from further consideration.

13.2.3 Comparison of Task IIIB Beam-Launch Bridge to
Scissors Bridge Concepts

The beam-launch bridge system has the following advantages with respect to the scissors bridge concepts:

Bridge Physical Characteristics: The beam-launch bridge has a span of 24 m; however, the draft ROC requires only a 60 ft (18.3 m) span.

Air Transport Characteristics: No advantages.

Ground Transport Characteristics: Slightly lower overall height.

Launch and Retrieval Characteristics:

- a. Lower launch profile.
- b. Less effect by wind and lateral slope.
- c. Somewhat lower fulcrum load on bank.
- d. Tow vehicle not required to remain at the launch site during launch.
- e. Manual launching may be possible in an emergency under some conditions.

RAM Characteristics: No advantages.

General Characteristics: No advantages.

The beam-launch bridge has the following disadvantages with respect to the scissors bridge concepts:

Bridge Characteristics: The design is considerably more complex, because of the need for bottom chord pinning mechanisms and the various features that interface with the launch mechanism.

Air Transport Characteristics:

- a. Greater overall length.
- b. Greater height at rear.
- c. Of all concepts, greatest total weight.
- d. A large adjustment of lunette height required during rearward loading into the aircraft because of the combination of overall length and height at the rear. The rearward-loading operation for this concept would be comparatively difficult.
- e. Longer preparation time for loading because the bridge is longer and therefore has more detachable deck extension sections.

Ground Transport Characteristics:

- a. Greater overall length.
- b. Of all concepts, greatest total weight.
- c. Of all concepts, smallest angles of approach and departure.
- d. Relatively poor overall cross-country mobility as a result of the combination of the above three characteristics.
- e. Longer preparation time after unloading from the aircraft because of the greater number of deck extension sections.

Launch and Retrieval Characteristics:

- a. Of all concepts, longest launch and retrieval times.
- b. More complex launch and retrieval procedures.
- c. More difficult to launch in less-than-adequate visibility.
- d. Greater difficulty in launching from a longitudinal slope to a higher far bank.
- e. The trailer required to be unhitched from the tow

vehicle before launch, causing exposure of personnel outside the vehicle. For all other concepts, the launch procedure can be controlled entirely from within the vehicle.

- f. Of all concepts, greatest vulnerability of the launch mechanisms to small arms and artillery fire.

RAM Characteristics:

- a. Probability of lower reliability because of moving interfaces between launch mechanism and bridge during launch and retrieval, and the complexity of the launch mechanism.
- b. Probability of lower availability because of the complexity of the launch mechanism.
- c. Maintainability difficulty because of the complexity of the launch mechanism and restricted accessibility to portions of the launch mechanism.
- d. Accessibility for decontamination procedures not as good.

General Characteristics:

- a. Highest estimated cost to design and build prototype systems.
- b. Greatest risk of not successfully completing development in time to meet schedule requirements.

It is apparent that the disadvantages of the beam-launch bridge system in comparison with the scissors bridge systems far outweigh its advantages. The beam-launch bridge is therefore eliminated from further consideration.

13.2.4 Comparison of Single-Scissors Bridge (Task I, IIA, and IIB)

Concepts to Double-Scissors Bridge (Task IIIC1 and IIIC2)

Concepts

The single-scissors bridge system concepts have the following advantages over the double-scissors bridge system concepts:

Bridge Characteristics:

- a. Less overall complexity: one hinge point vs. two.
- b. Simpler folding mechanisms because they are required to exert only tension.
- c. Lower weight.

Air Transport Characteristics: No lunette height adjustment during rearward loading in the aircraft because of lower height at the rear, although the Task I bridge will clear the top of the cargo space by only about 4 in. The single-scissors concepts are therefore easier to load in the rearward direction than the double-scissors concepts.

Ground Transport Characteristics: No advantages.

Launch and Retrieval Characteristics:

- a. Shorter estimated launch and retrieval times.
- b. Less complex launch and retrieval procedure, because there is only one folding mechanism to operate.
- c. Lower upward load on tow pintle.
- d. Lower fulcrum load on bank.

RAM Characteristics: The single-scissors concepts have a small advantage in reliability, availability, and maintainability because of the simpler construction of the bridge.

General Characteristics: Lower estimated cost for design and construction of prototypes.

The double-scissors bridge concepts have the following advantages over the single-scissors bridge concepts:

Bridge Characteristics: The bridge folds into a more compact package.

Air Transport Characteristics: Shorter overall length.

Ground Transport Characteristics:

- a. Shorter overall length.
- b. Greater angles of approach and departure.
- c. Significantly better cross-country mobility as a result of combination of the above two characteristics.

Launch and Retrieval Characteristics:

- a. Less space on the bank required.
- b. Lower launch height. However, this potential advantage is offset by several factors:
 - o Center of wind pressure is quite high in comparison to total height, so that wind moment is nearly as great as that of the single-scissors bridge.
 - o Center of gravity at maximum launch height is higher than that of the single-scissors bridge, so lateral slope effect is greater.
 - o Longer launch time offsets the value of lower launch profile.

RAM Characteristics: No advantages.

General Characteristics: No advantages.

It is apparent that the single-scissors concepts have several important advantages over the double-scissors concepts; the principal advantage of the double-scissors concepts is cross-country mobility. The single-scissors concepts are therefore preferred. However, none of the concepts offers cross-country mobility characteristics equivalent to typical existing military trailers. Therefore, it is possible that cross-country mobility may

be an overriding consideration that would mandate selection of a double-scissors bridge system.

13.2.5 Comparison of Task I Scissors Bridge Concept to Task II Scissors Bridge Concepts

The Task I concept has the following advantages over the Task II concepts:

Bridge Characteristics: Only new design required is addition of detachable deck extensions.

Air Transport Characteristics: No advantages.

Ground Transport Characteristics: No advantages.

Launch and Retrieval Characteristics: Minimum redesign of existing launch mechanism required.

RAM Characteristics: No advantages.

General Characteristics:

- a. Lower estimated cost to design and build prototype systems.
- b. Lowest risk of not successfully completing development in time to meet schedule requirements.

The Task II concepts have the following advantages over the Task I concept:

Bridge Characteristics: Hydraulic cylinders removed from the bridge.

Air Transport Characteristics: Easier rearward loading into the aircraft as a result of lower height at the rear.

Ground Transport Characteristics: Better cross-country mobility because of the significantly larger departure angle.

Launch and Retrieval Characteristics: No advantages.

RAM Characteristics: No advantages.

General Characteristics: No advantages.

The advantages of the Task II concepts in air and ground transportability characteristics are considered to outweigh the somewhat lower cost and development risk of the Task I concept. The Task I concept is therefore eliminated from further consideration, leaving only a choice between the Task IIA and IIB concepts.

13.2.6 Comparison of Task IIA and Task IIB Scissors Bridge Concepts

The Task IIA concept has the following advantages over the Task IIB concept:

Bridge Characteristics: Slightly lighter weight.

Air Transport Characteristics: Somewhat lower weight.

Ground Transport Characteristics:

- a. Somewhat lower weight.
- b. Somewhat lower overall length.

Launch and Retrieval Characteristics:

- a. Slightly shorter launch and retrieval times.
- b. Slightly lower upward load on fulcrum.
- c. Slightly lower fulcrum load on bank.

RAM Characteristics: No advantages.

General Characteristics:

- a. Somewhat lower cost to design and build prototype systems.
- b. Somewhat lower risk of not successfully completing development in time to meet schedule requirements.

The Task IIB concept has the following advantages over the Task IIA concept:

Bridge Characteristics: No loose pieces to stow.

Air Transport Characteristics: Shorter preparation time.

Ground Transport Characteristics:

- a. Shorter preparation time.
- b. Smaller overall width.

Launch and Retrieval Characteristics: No advantages.

RAM Characteristics: No advantages.

General Characteristics: No advantages.

In the comparison of these two bridge designs, the detachable deck extensions of the Task IIA concept are considered to be equivalent to the folding cross-bracing of the Task IIB concept with respect to complexity. The advantages of the Task IIB concept for ease of preparation after unloading from the aircraft and the ability to be towed to the launch at reduced width are considered more important than the several marginal advantages of the Task IA concept. The Task IIB concept is therefore the selected preferred concept.

14.0 COMPOSITE

14.1 Summary

Under Task II, we investigated application of composite materials to the bridge and launch mechanism members. The use of composite materials in the trailer-mounted assault bridge is not considered feasible in view of the early state of current development of fiber composites in military bridges and the short development time available in this bridge program. Accordingly, the investigation of composite materials was not a major part of this study; however, the approximate impact on weight and cost of the use of such materials was assessed.

14.2 Bridge

Application of a commonly used, commercially available, carbon fiber epoxy composite to the Task I scissors-bridge design provided a basis for estimating weight and cost. The principal opportunity for weight saving is in the main tensile members, which are the bottom chords. In the scissors-bridge design, these members are 7005-T53 aluminum extrusions, each weighing approximately 5.2 lb/ft, or a total of 1290 lb, amounting to about 18% of total bridge weight. Figure 20 illustrates a conceptual method of using the carbon fiber composite in the bottom chords. This configuration is not a suggested design since it was not investigated in detail; it is intended only to be a hypothetical configuration upon which we could base estimates of weight saving and cost impact. The concept takes into consideration the following factors:

- o The composite material is vulnerable to damage and should be located so that it is protected from accidental damage. This implies that the composite should be placed inside the remaining metal portion of the structure.

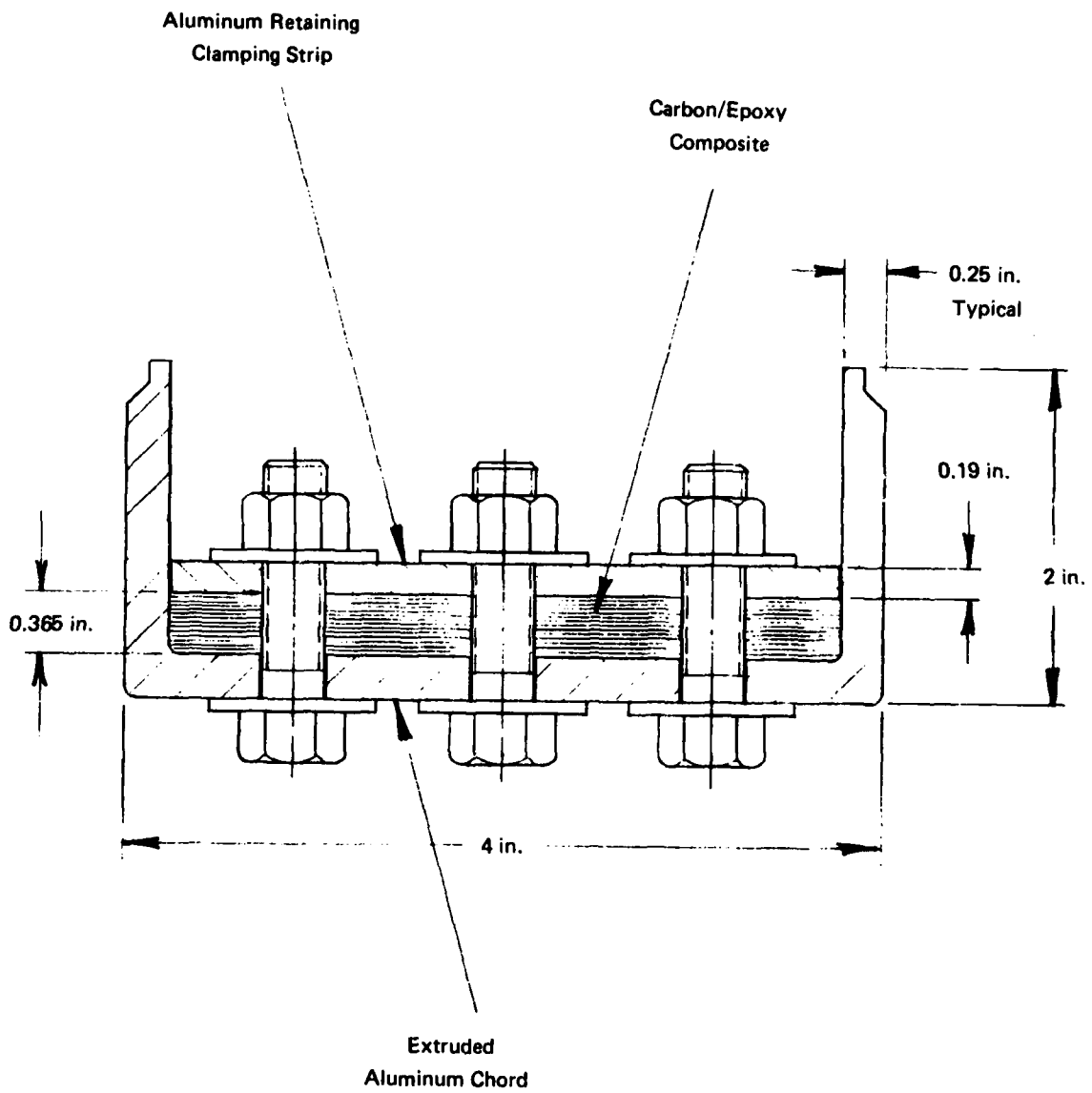

FIGURE 20 CONCEPT OF COMPOSITE BOTTOM CHORD

Wt. of aluminum in composite chord = 2.40 lb/ft	= 74 lb
Wt. of composite in composite chord = 0.78 lb/ft	= <u>24</u> lb
Basic wt. of composite chord = 3.18 lb/ft	= 98 lb
Basic weight saving per chord	= 63 lb
Wt. of aluminum reinforcing sheet	= 9 lb
Wt. of additional fasteners	= <u>7</u> lb
Additional weight	= 16 lb
Net weight saving per chord	= 47 lb
This weight saving is 29% of present chord weight.	
Net weight saving for bridge	= 376 lb
This weight saving is 5.4% of bridge weight.	

This weight saving is likely too small to permit any significant reduction in launch mechanism or trailer weight. It is also too small to have a significant impact on air transportability or cross-country mobility. The bulk and configuration of the bridge and trailer package are more important factors in air and ground transportability, and they are largely dictated by the bridge length and width requirements. The height of the bridge could be reduced somewhat through the use of the composite chord, but at some sacrifice in weight saving, and the significance of the height reduction in transportability would be very small.

The added construction cost for the composite chord is estimated as follows:

Material cost (per bridge):

All aluminum extrusion chord at \$3.85	\$ 4,960
Composite chord:	
Aluminum extrusion at \$3.85/lb	\$ 2,280
Carbon epoxy prepreg at \$70/lb	13,440
Aluminum sheet at \$1.90/lb	140
Fasteners	<u>150</u>
Total material for composite chord	\$16,010
Net added material cost	\$11,050

Labor cost (per bridge) at \$40/hr:

Lay and bond composite prepreg	\$ 2,560
Cut and fasten reinforcing sheet (drill holes)	<u>1,600</u>
Total added labor cost	\$ 4,160
Total added cost per bridge	\$15,210

14.3 Launch Mechanism

Application of composite materials to the scissors-bridge launch mechanism does not appear to offer weight savings that would compensate for the more complicated and costly construction. The parts are relatively small and complex. The basic structure of the two principal components weighs approximately 750 lb. If a 25% weight saving could be achieved, it would amount to approximately 190 lb, and the added cost would be high.

14.4 Trailer

Another possible application for composites is in the main longitudinal beams of the trailer, which must carry a heavy bending moment during launch. The weight of these members in the scissors-bridge trailer is approximately 880 lb. A 25% weight saving would amount to about 220 lb, and the construction would be relatively simple compared to the launch mechanism. However, the composite material would have to be applied in such a way that it would be protected from abuse because the trailer may be used for general-purpose hauling when a bridge is not on board.

APPENDIX A
PRELIMINARY DESIGN DRAWINGS

PRECEDING PAGE BLANK-NOT FILLED

H
G
F
E
D
C
B
A

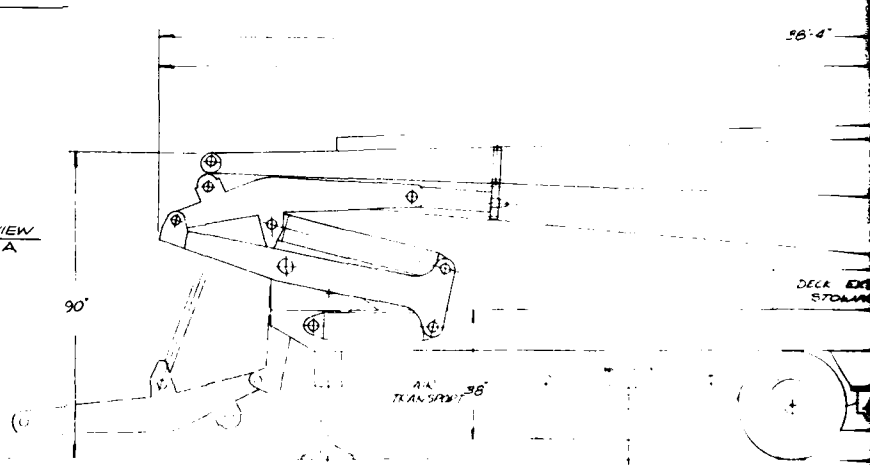
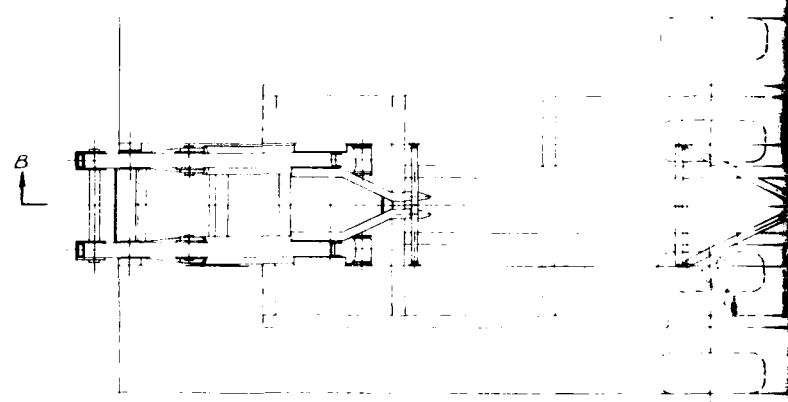
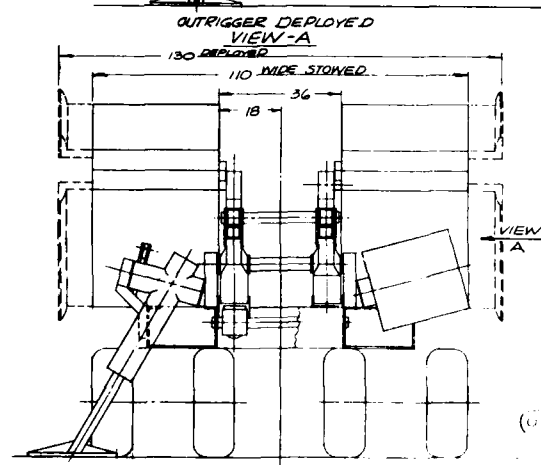
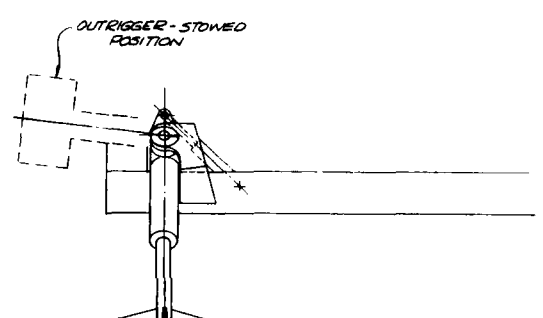

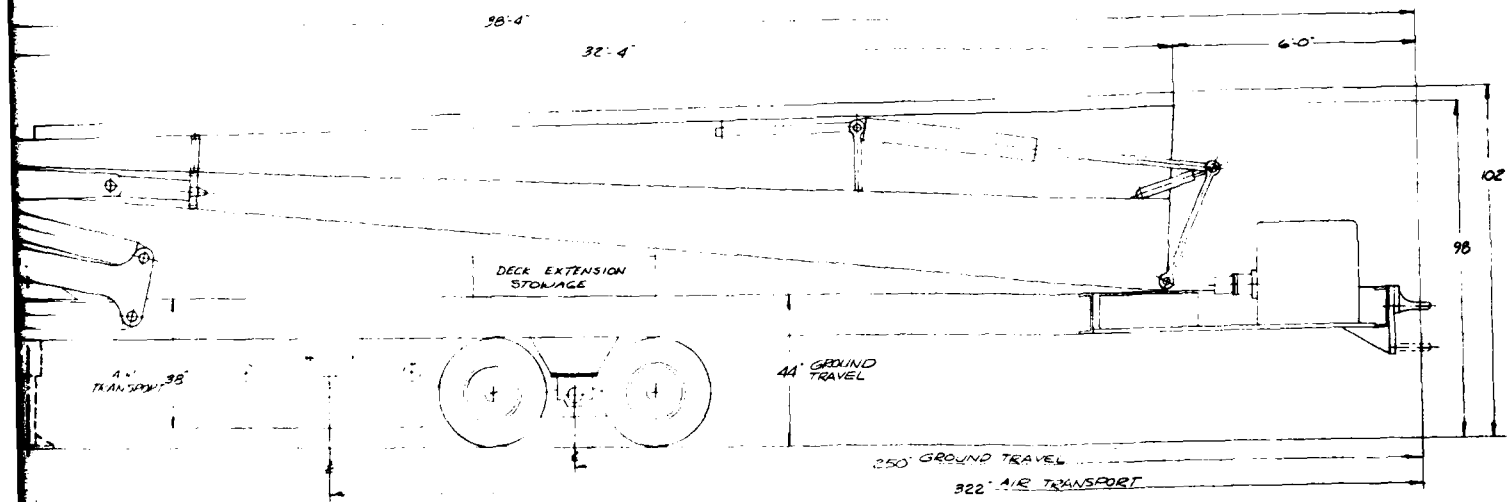
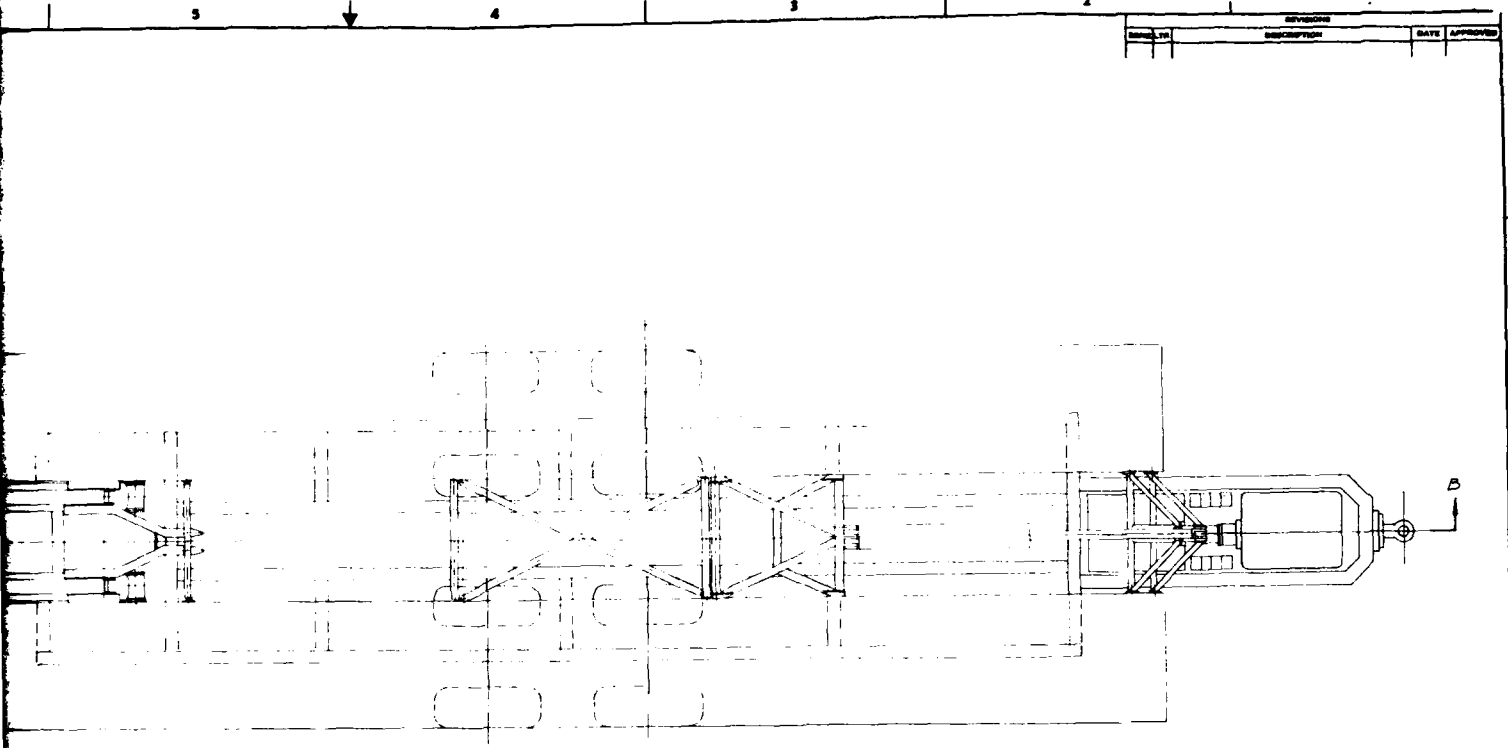

SECTION B-B

REV.	DESCRIPTION	DATE	APPROVED

NO.	REV.	DESCRIPTION	DATE	APPROVED

ARTHUR D. LINDE INC. ENGINEERS ARCHITECTS SURVEYORS 866... CI	LIST OF PARTS CLASS 30 ASSAULT BRIDGE PRELIMINARY DESIGN TASK I. SCISSORS BRIDGE E 75629 4193-007
--	--

E 4193-007

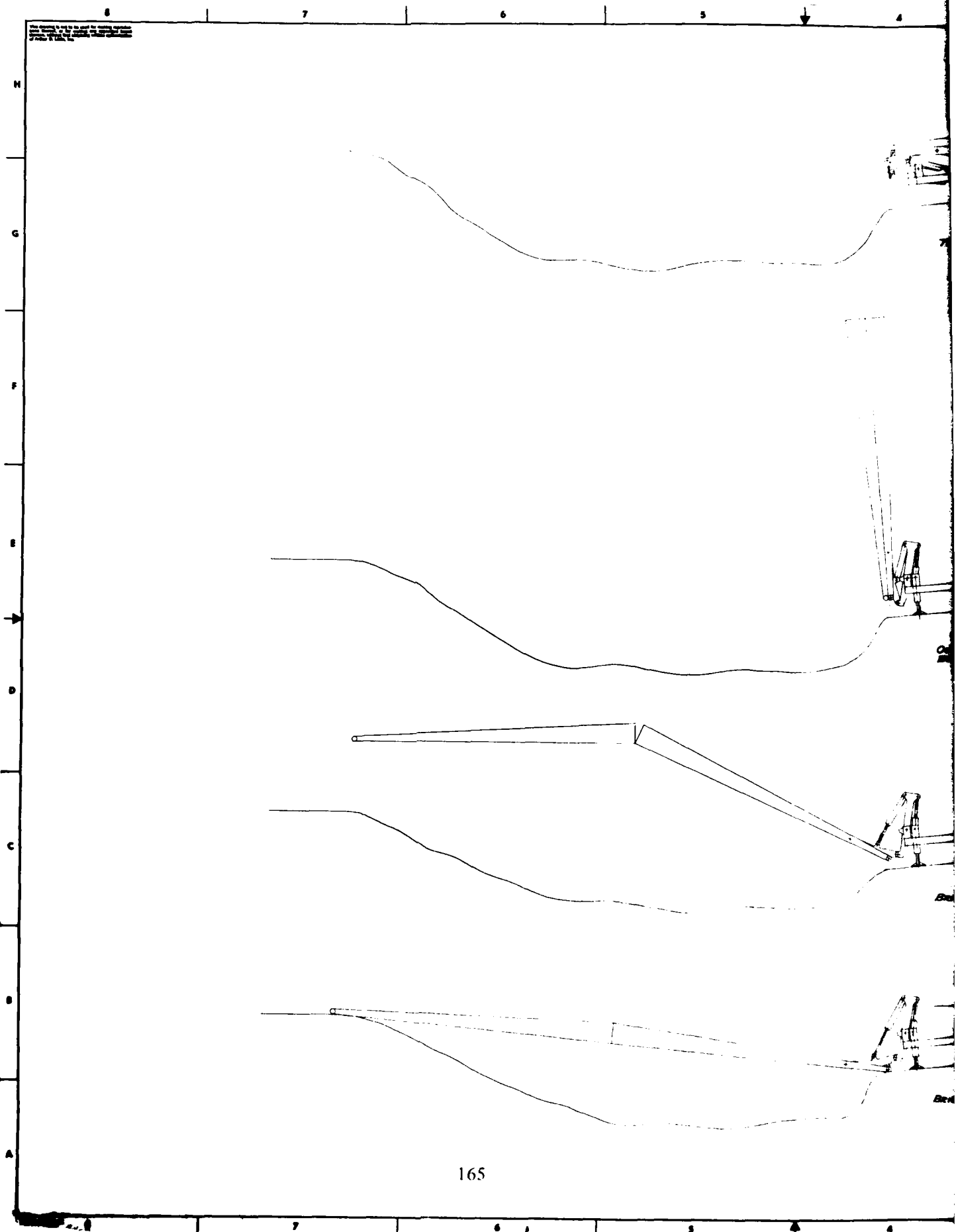

5 4 3 2 1

REVISIONS		
NO.	DESCRIPTION	DATE APPROVED



TRAILER IS POSITIONED.

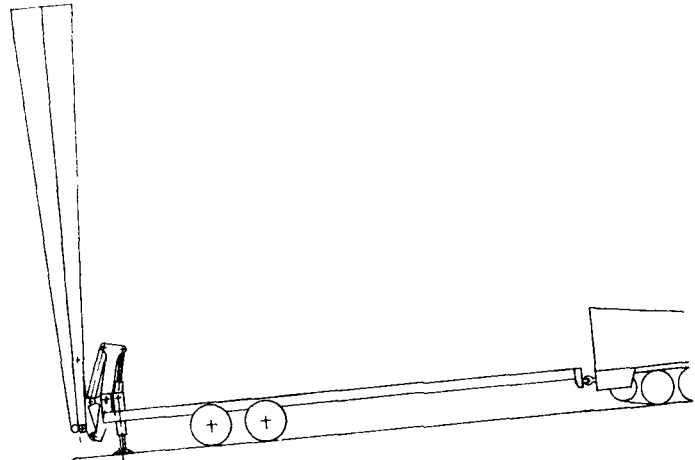

OUTRIGGERS ARE DEPLOYED. BRIDGE IS ELEVATED.

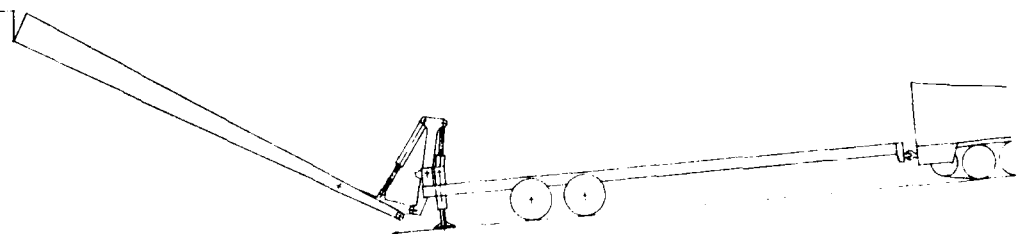

BRIDGE IS PARTIALLY UNFOLDED + LOWERED



BRIDGE IS FULLY EXTENDED + SET DOWN.

14193-007

REV	DATE	DESCRIPTION	APPROVED

WELDER CERTIFICATE NAME: _____ NO. _____ EXPIRES: _____		SCALE DATE DATE: 01/10/88 TIME: 10:15 AM	
DESIGNER NAME: _____ NO. _____		CONTRACT NO. _____	
PROJECT NAME: _____ NO. _____		APPROVED NAME: _____ NO. _____	
LIST OF PARTS Arthur D. Uncle Inc. CLASS 30 ASSAULT BRIDGE PRELIMINARY DESIGN TANK 1 SCISSORS BRIDGE			
REV NO. 1 DATE: 01/10/88		REV NO. 2 DATE: 01/10/88	
REV NO. 3 DATE: 01/10/88		REV NO. 4 DATE: 01/10/88	

5 4 3 2 1

2

THIS DRAWING IS THE PROPERTY OF THE AIR FORCE AND IS LOANED TO YOU BY THE AIR FORCE. IT IS TO BE RETURNED TO THE AIR FORCE AT THE END OF THE LOAN PERIOD.

H
G
F
E
D
C
B
A

7

6

5

4

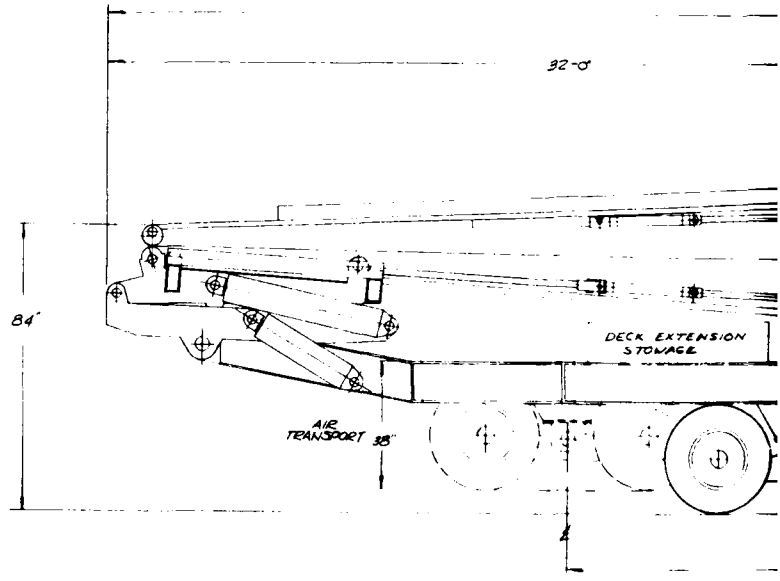
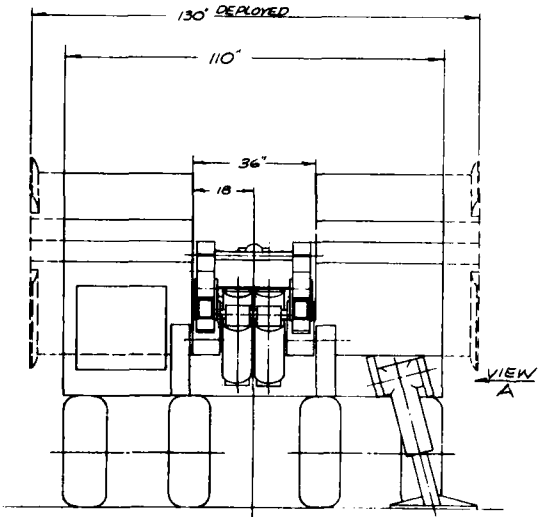
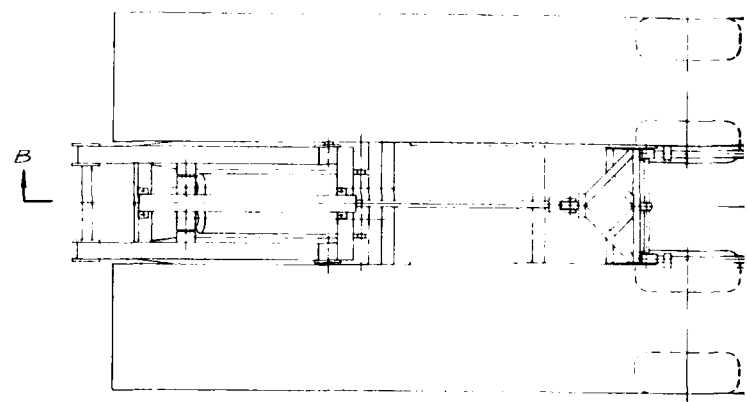

SECTION



VIEW - A OUTRIGGER

8

7

6

5

4

REVISED TO	DESCRIPTION	DATE	APPROVED

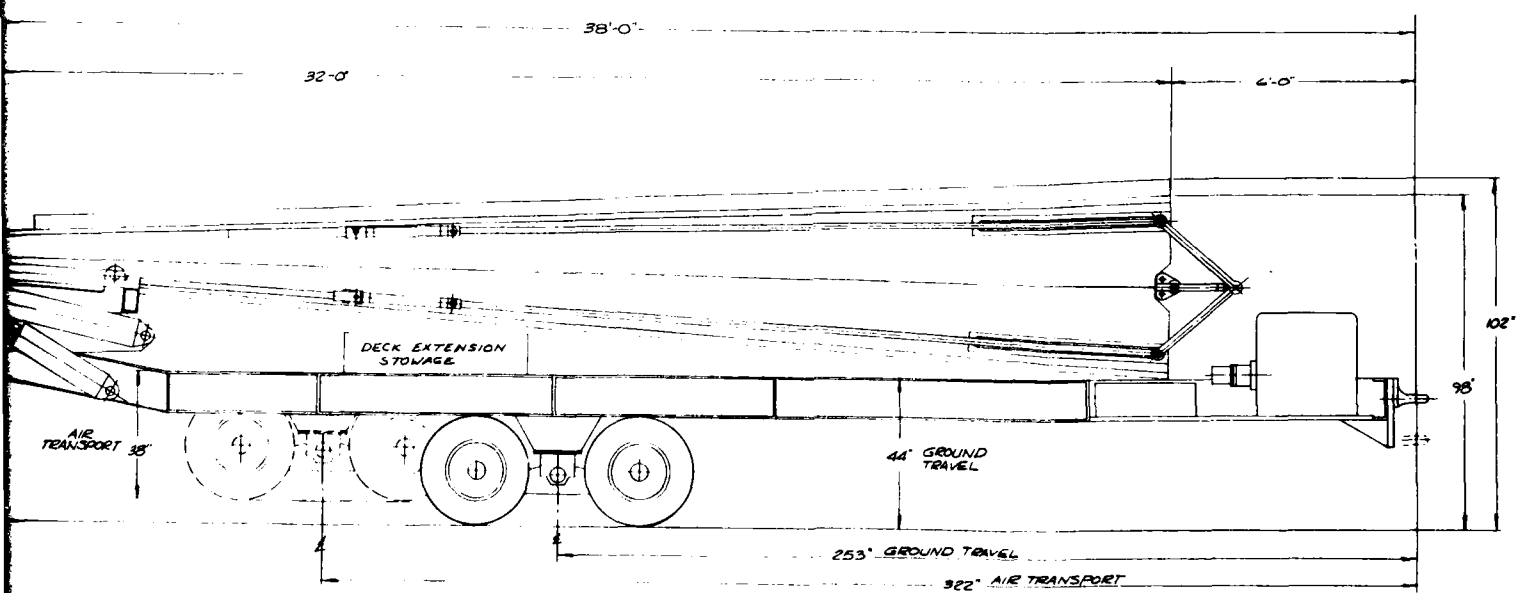
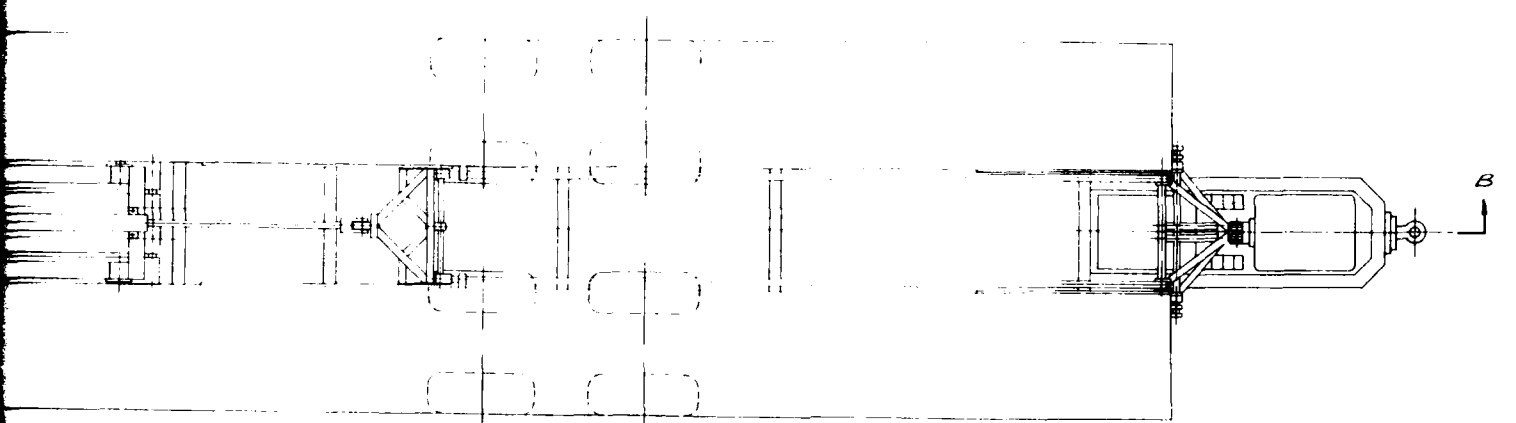

SECTION B-B

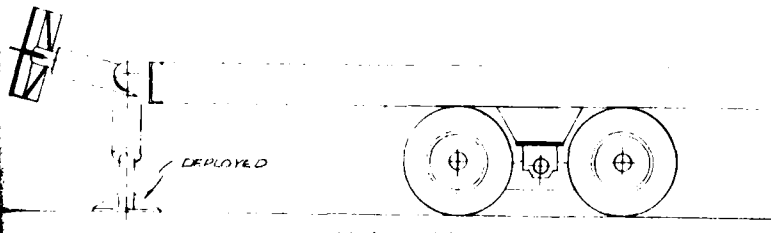

VIEW-A OUTRIGGER STOWED

REVISED TO	DESCRIPTION	DATE	APPROVED

DESIGN APPROVED DATE 10/1/72 DRAWN BY NAME NAM CHECKED BY APPROVED BY DO NOT SCALE THIS DRAWING	MANUFACTURED BY Arthur D Little Inc. CLASS 30 ASSAULT BRIDGE PRELIMINARY DESIGN TASK IIA SCISSORS BRIDGE E 75629 4193-008 06618-C1
---	--

2

THIS DRAWING IS THE PROPERTY OF THE AIR FORCE AND IS LOANED TO YOU BY THE AIR FORCE. IT IS TO BE RETURNED TO THE AIR FORCE AT THE END OF THE LOAN PERIOD. IT IS NOT TO BE REPRODUCED OR TRANSMITTED IN ANY FORM OR BY ANY MEANS, ELECTRONIC OR MECHANICAL, INCLUDING PHOTOCOPYING, RECORDING, OR BY ANY INFORMATION STORAGE AND RETRIEVAL SYSTEM.

H
G
F
E
D
C
B
A

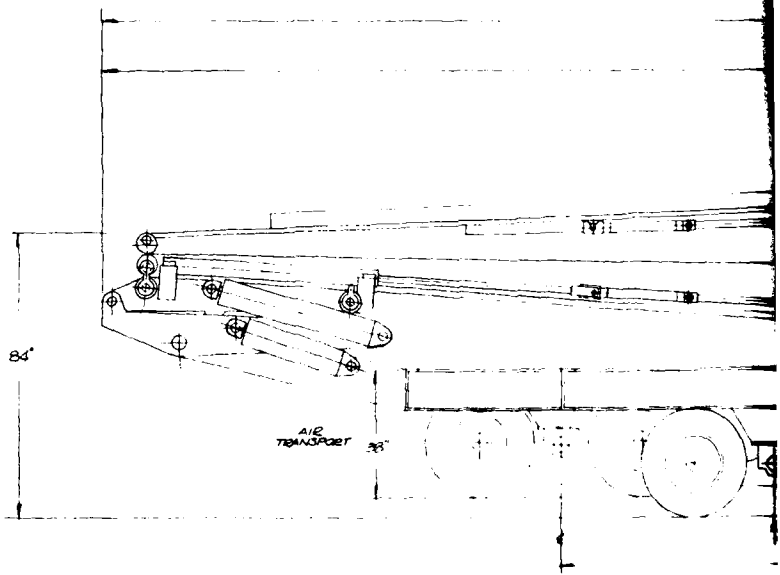
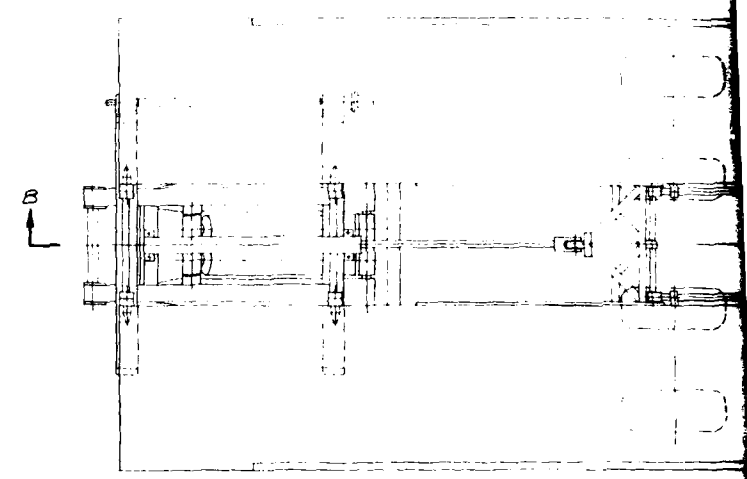
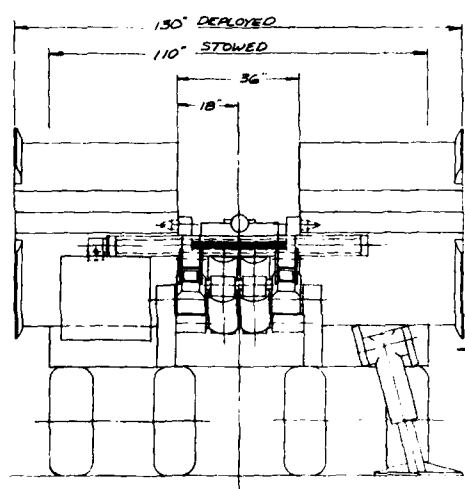

SECTION

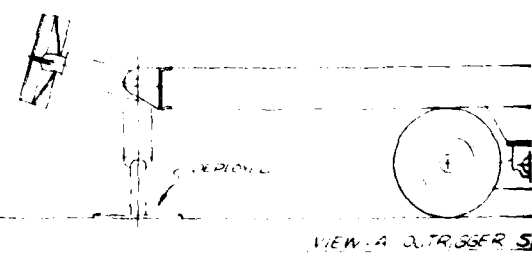

VIEW A (TRANSFER)

5 4 3 2 1

NO.	DESCRIPTION	DATE	APPROVED

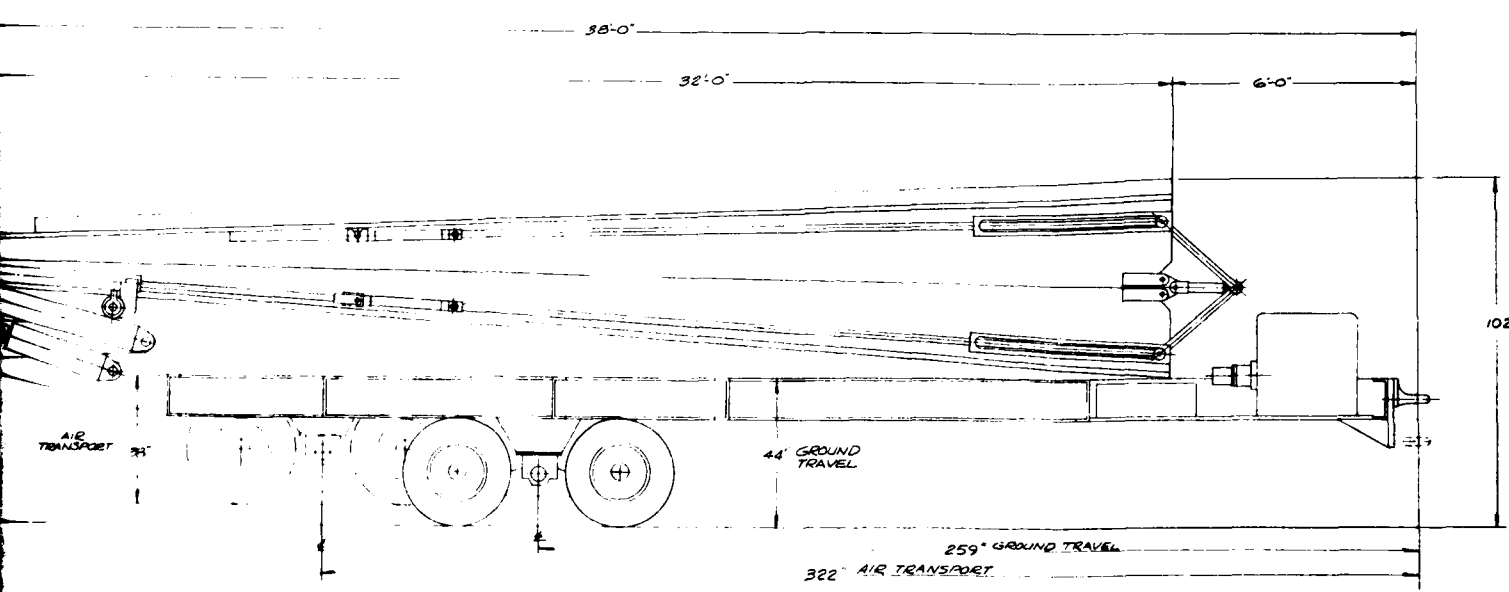
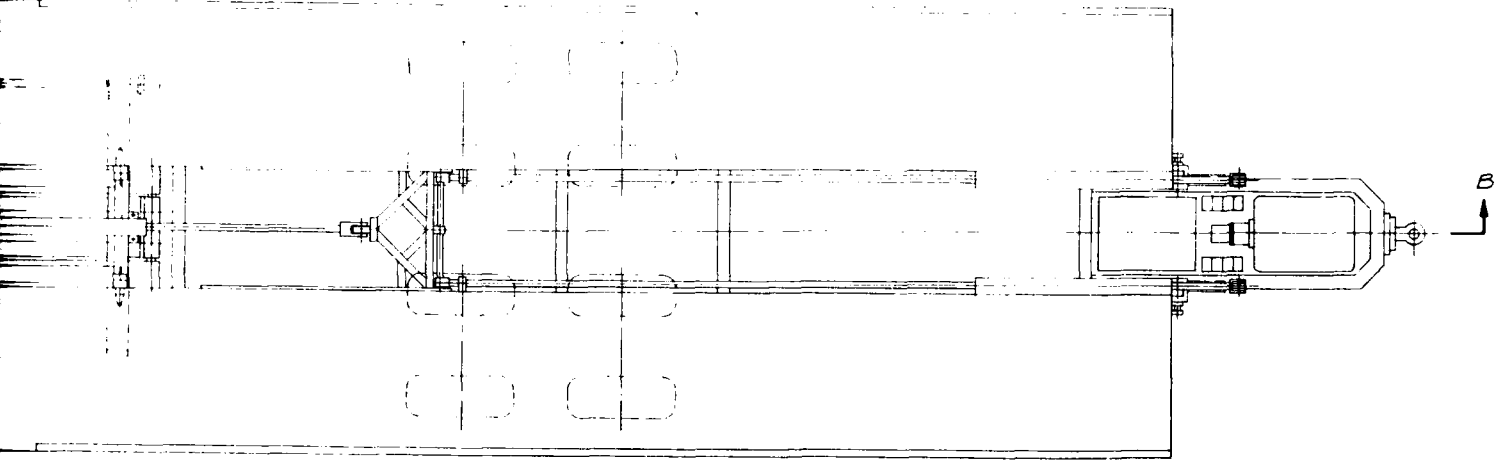

SECTION B-B

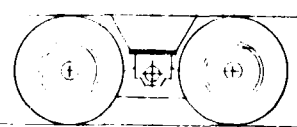
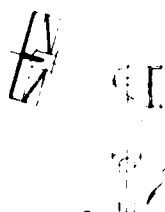

VIEW-A OUTRIGGER STOWED

REV.		DATE	DESCRIPTION	BY	CHKD.

ARTHUR D. LITTLE, INC. CONSULTING ENGINEERS	CLASS 30 ASSAULT BRIDGE PRELIMINARY DESIGN TASK II B. SCISSORS BRIDGE
PROJECT NO. 75629 DRAWING NO. 4193-009	SCALE: AS SHOWN DATE: 12/2/52

5 4 3 2 1

N
G
C
F
E
D
C
B
A

100-5617-1

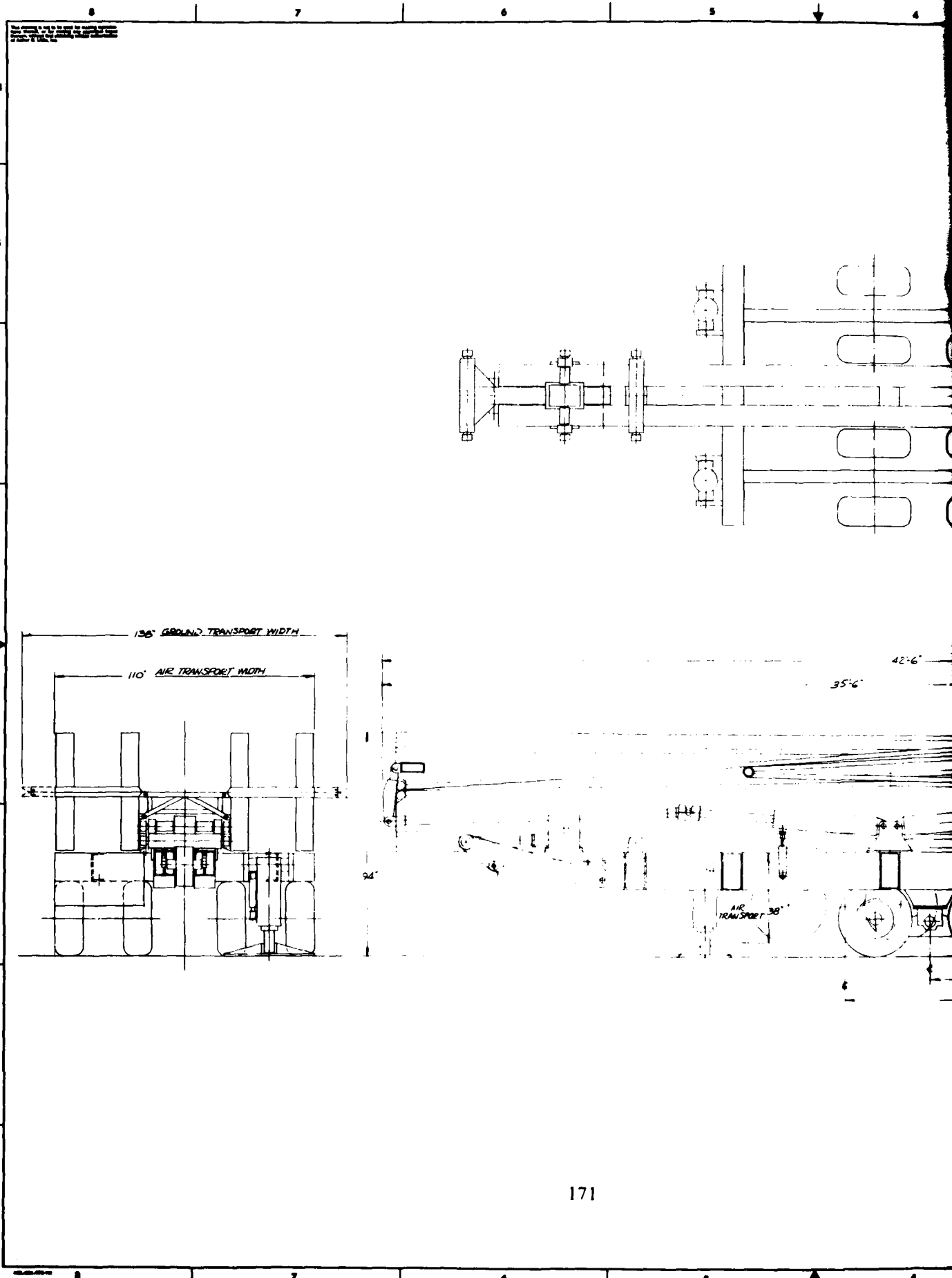

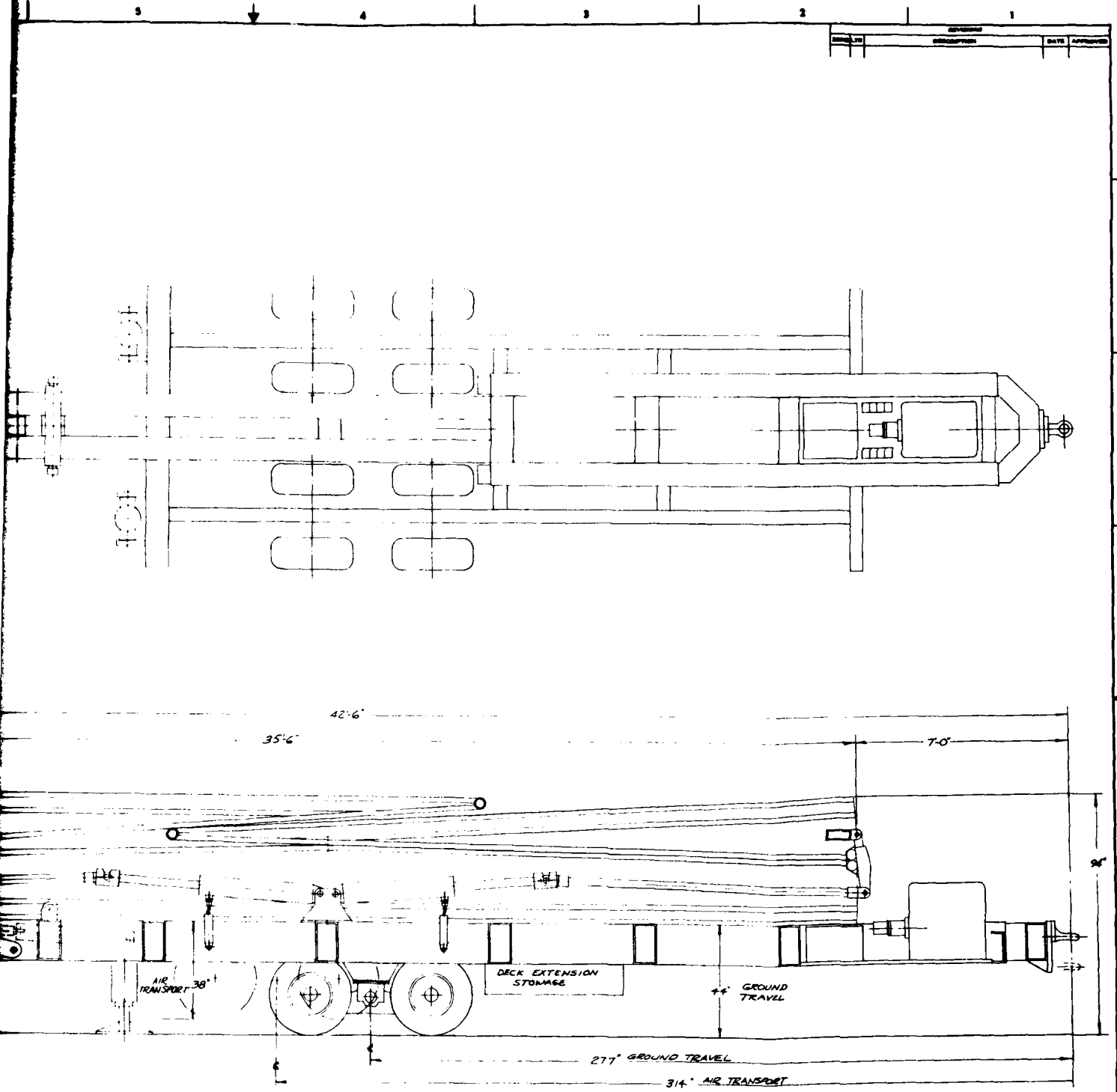

REVISION	DATE	APPROVED

H
G
F
E
D
C
B
A
 1010-517

NO.	DESCRIPTION	QUANTITY	UNIT	PERCENTAGE ON	MATERIAL
LIST OF PARTS					
CLASS 30 ASSAULT BRIDGE PRELIMINARY DESIGN TASK IIA. FLIP-LAUNCH BRIDGE		Arthur D Little Inc. CONSULTING ENGINEERS			
DRAWING NO. 86618-01 DATE 3/1/51		PROJECT NO. 75629 DRAWING NO. 4193-010			
NEXT COPY USED ON APPLICATION		CHECKED BY: [Signature] DATE: 3/1/51			

2

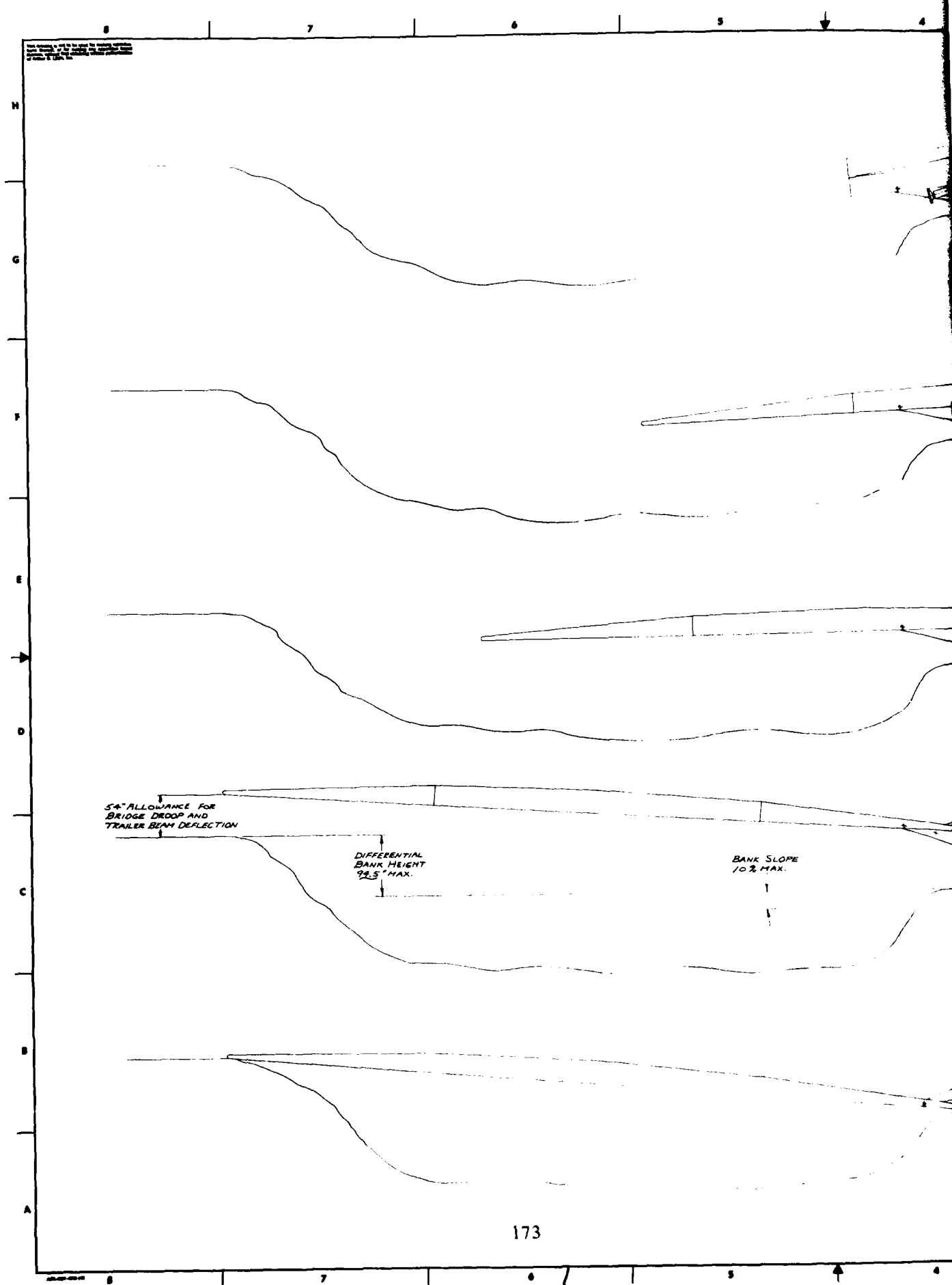

5" ALLOWANCE FOR
BRIDGE DROOP AND
TRAILER BEAM DEFLECTION

DIFFERENTIAL
BANK HEIGHT
94.5" MAX.

BANK SLOPE
10% MAX.

NO.	DESCRIPTION	DATE	APPROVED
-----	-------------	------	----------

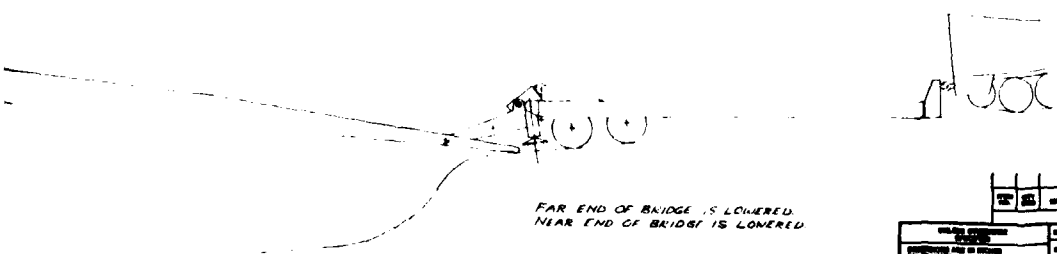
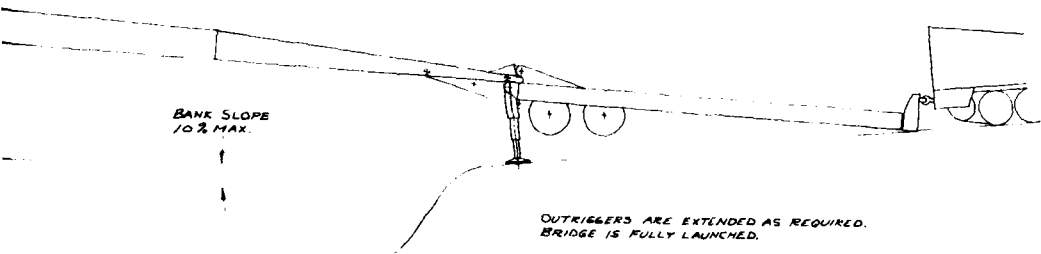
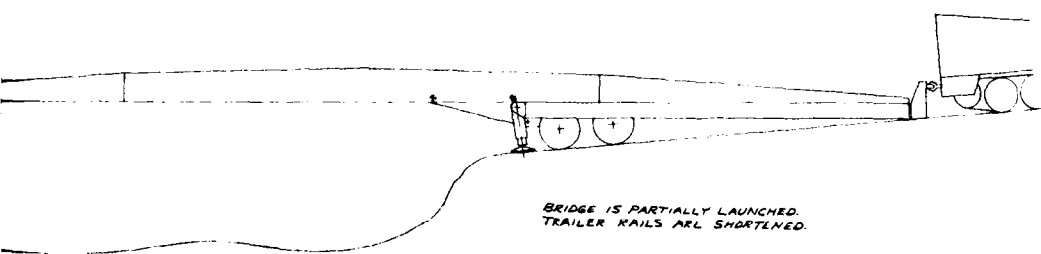
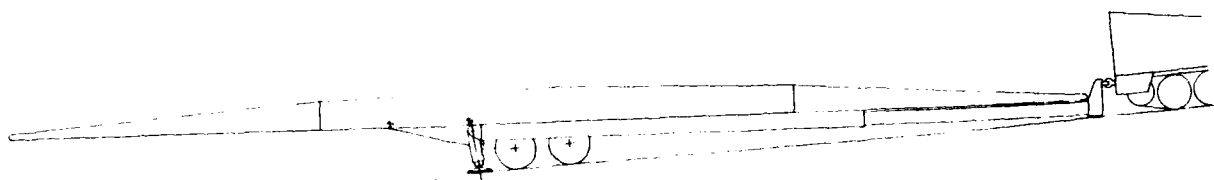
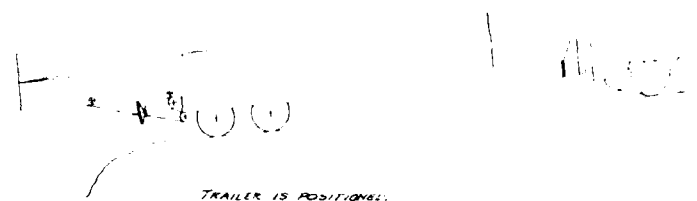

TITLE: CLASS 80 ASSAULT BRIDGE PRELIMINARY DESIGN TABLE TOP LAUNCH BRIDGE LAUNCH SERVICE.	
PROJECT NO.: 75629 DRAWING NO.: 86618-01	SHEET NO.: 1 OF 2 DATE: 4/93-010
COMPANY: Arthur D Little Inc. ADDRESS: 1000 N. 17th St., Suite 100, Phoenix, AZ 85016 PHONE: (602) 955-1100 FAX: (602) 955-1101 WWW: www.adl.com	

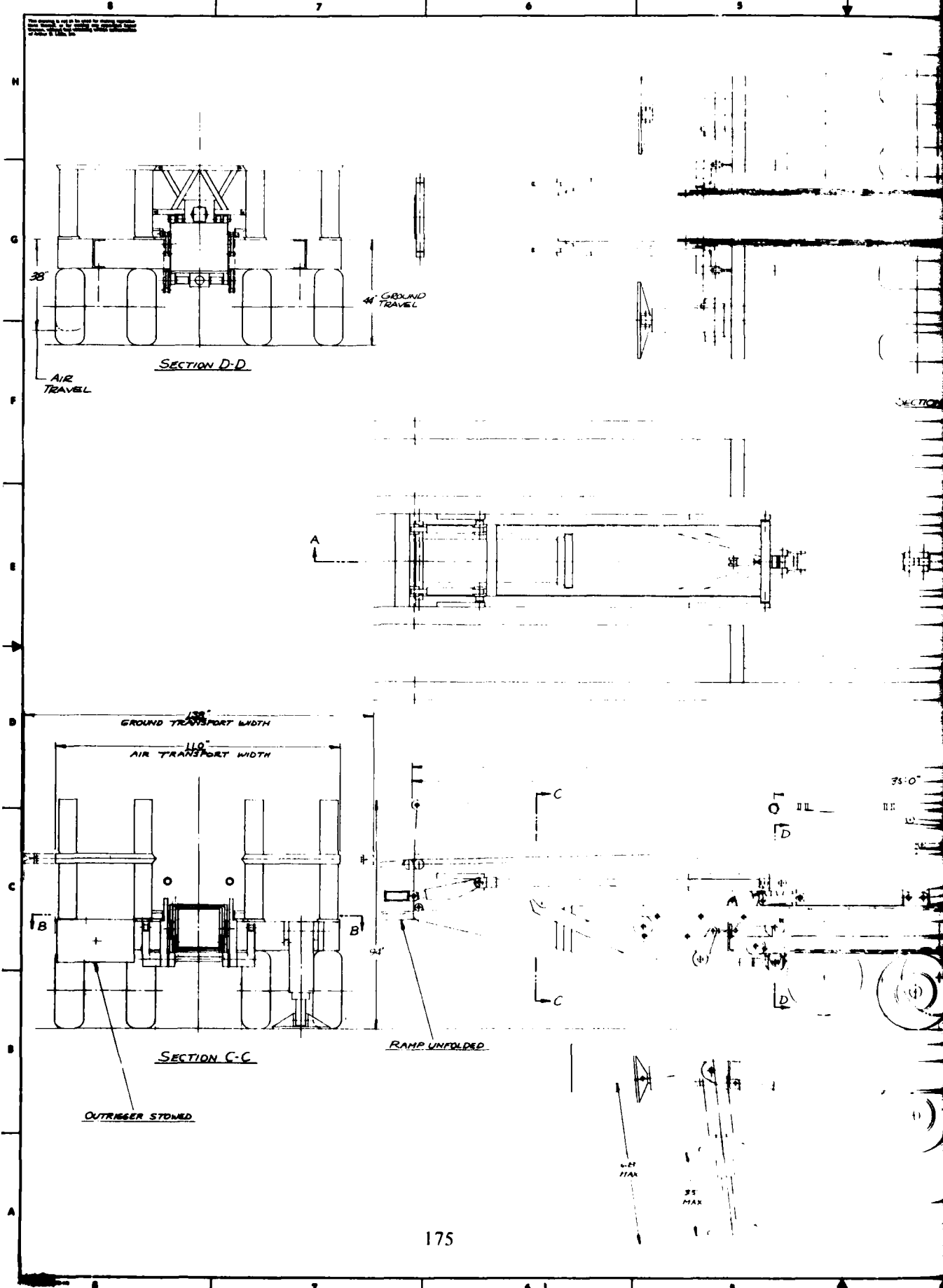

5 4 3 2 1

NO.	REVISION	DATE	APPROVED

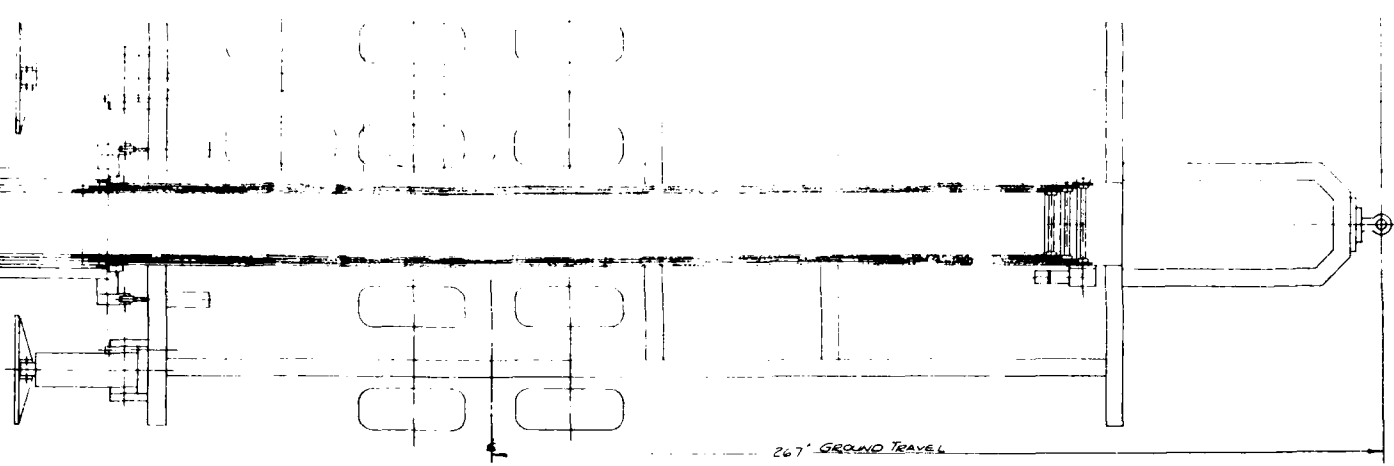

SECTION B-B

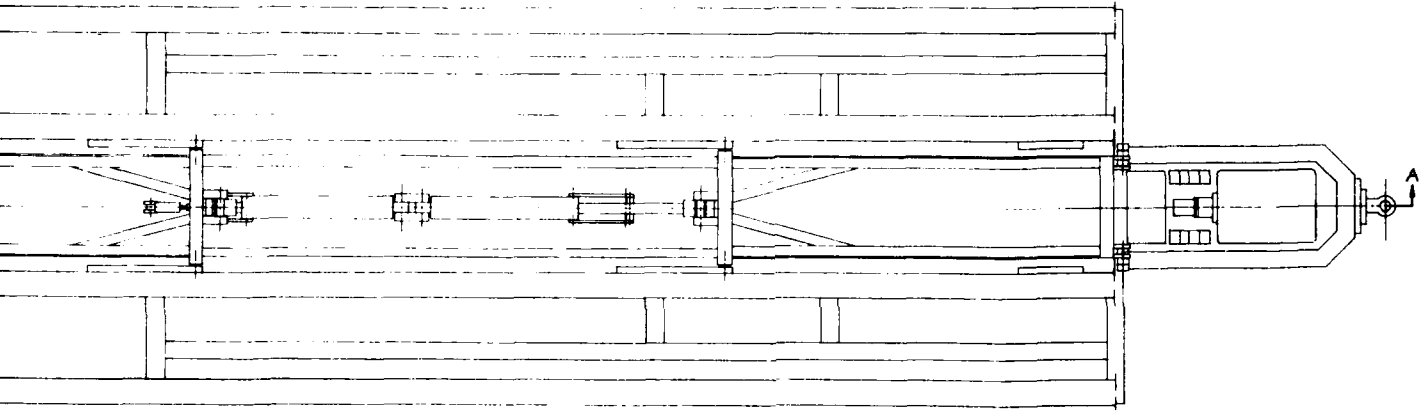

SECTION A-A

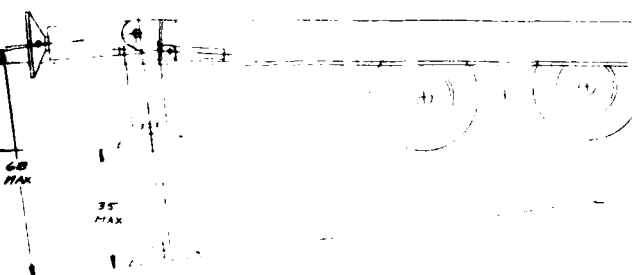
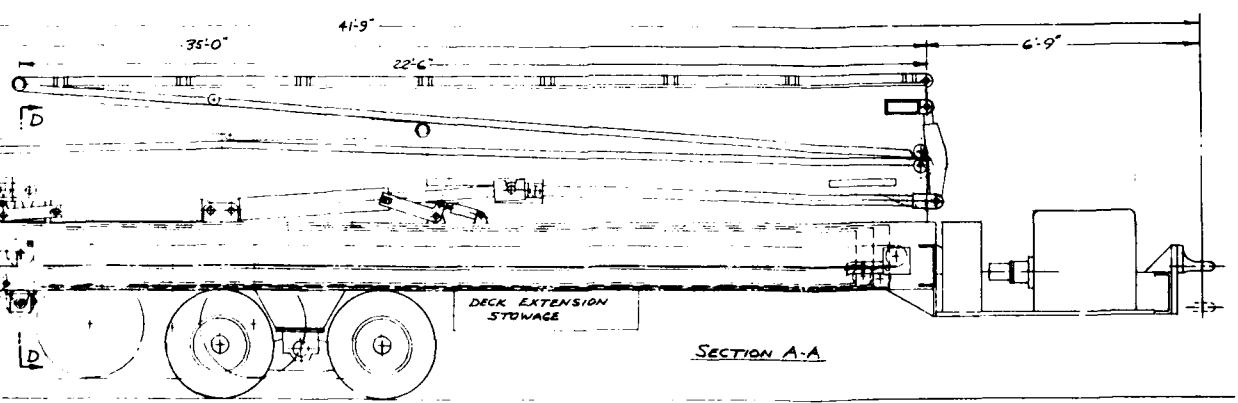

REV		DATE	DESCRIPTION	BY	CHKD

REV		DATE	DESCRIPTION	BY	CHKD

CLASSIFICATION DESIGNATED BY: 2400001 WPH PROJECT: CLASS 30 ASSAULT BRIDGE DRAWING NO: 75629 DATE: 1953-01-11	LIST OF PARTS Arthur D Little Inc. CLASS 30 ASSAULT BRIDGE PRELIMINARY DESIGN TASK II B BERM LAUNCH BRIDGE E 75629 4193-011
--	---

5 4 3 2 1

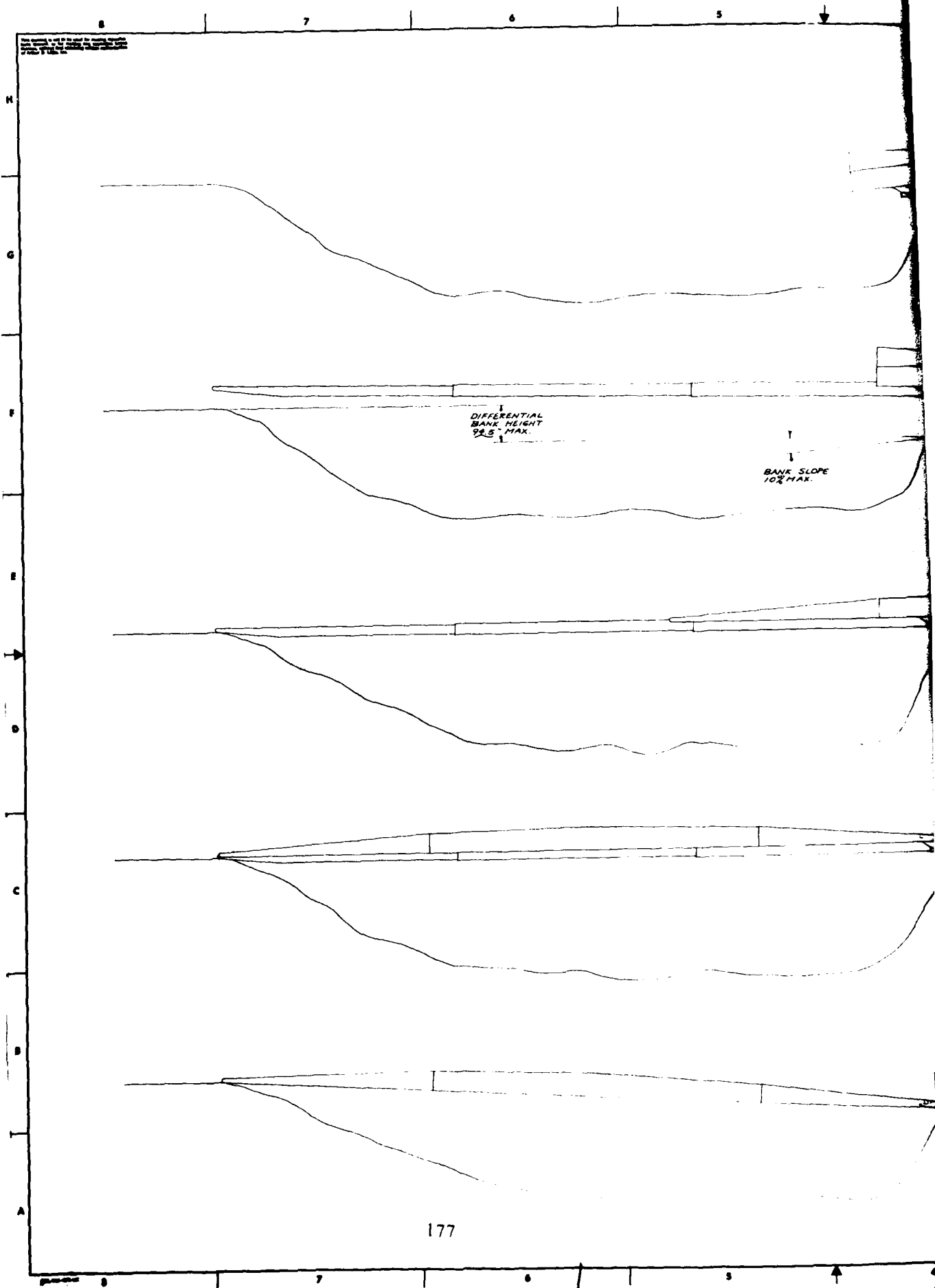

5 4 3 2 1

REV.	DESCRIPTION	DATE	APPROVED

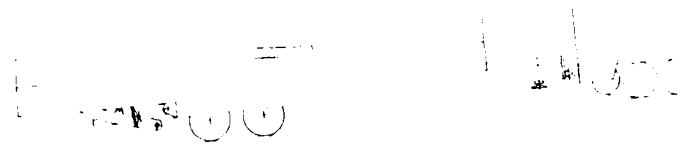

TRAILER IS POSITIONED

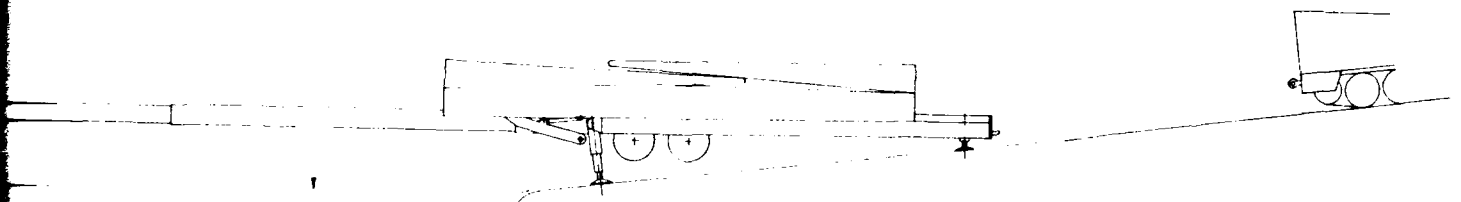

BANK SLOPE 10% MAX.

FRONT OF TRAILER IS LOWERED
OUTRIGGERS ARE DEPLOYED + LOWERED
BEAM IS EXTENDED ACROSS GAP

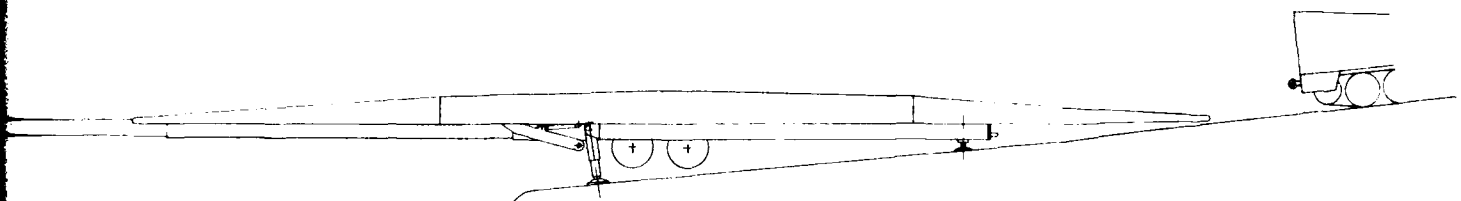

FAR END OF BEAM IS LOWERED.
BRIDGE RAMPS ARE EXTENDED + LOCKED.

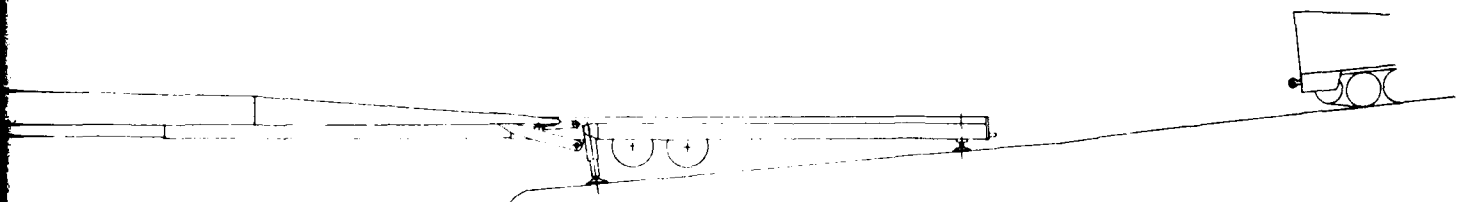

BRIDGE IS ROLLED ACROSS GAP

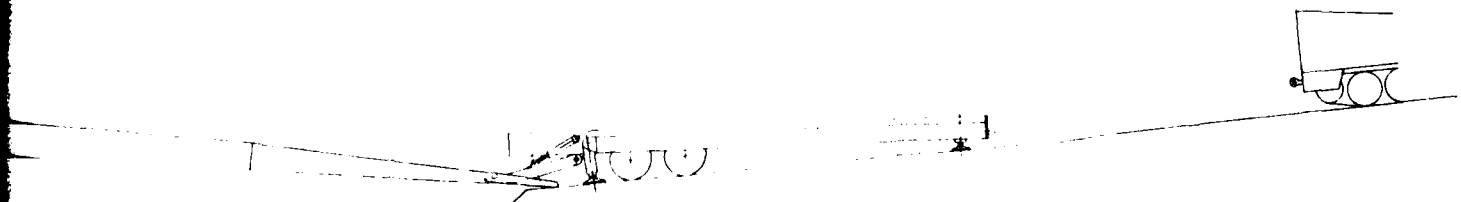

BEAM IS RETRACTED
NEAR END OF BRIDGE IS LOWERED

REV.	NO.	DATE	DESCRIPTION	APPROVED

TITLE: CLASS 30 ASSEMBLY BRIDGE PROJECT: PRELIMINARY DESIGN DRAWING NO.: 75629 DATE: 199-01	LIST OF PARTS Arthur D Little Inc. CONSULTING ENGINEERS 1400 B WYOMING ST PITTSBURGH, PA 15222 PHONE: 412-766-1000 FAX: 412-766-1001 WWW: www.adlittle.com
--	--

DRAWN BY: WJW CHECKED BY: WJW DATE: 199-01	PROJECT NO.: 75629 DRAWING NO.: 193-011 SCALE: AS SHOWN
---	--

5 4 3 2 1

1945

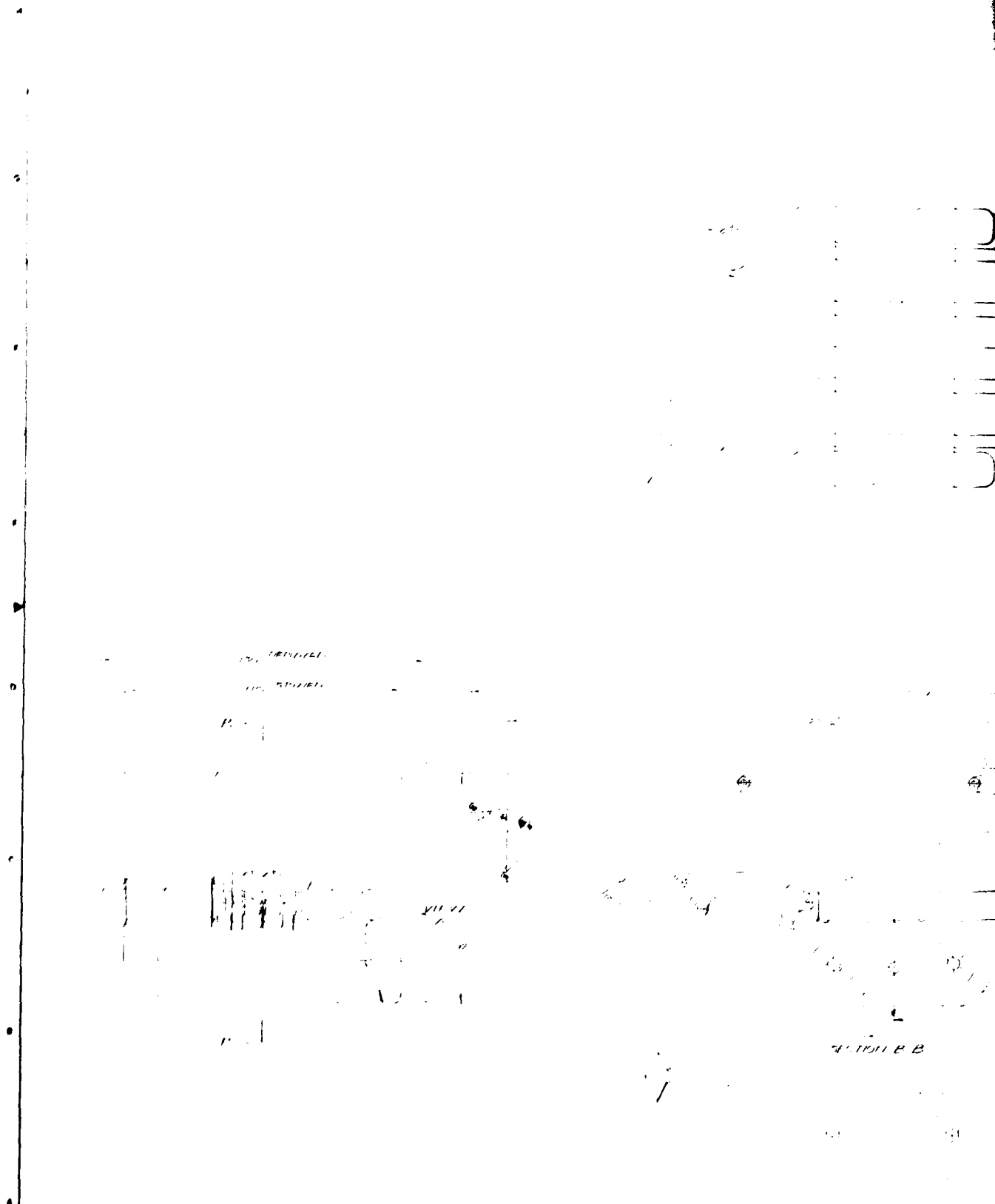

1. DRIVE SHAFT

2. DRIVE SHAFT

3.

4.

5.

6.

7. DRIVE SHAFT

5

4

3

2

1

NO.	DESCRIPTION	DATE	APPROVED

M

G

F

E

D

C

B

A

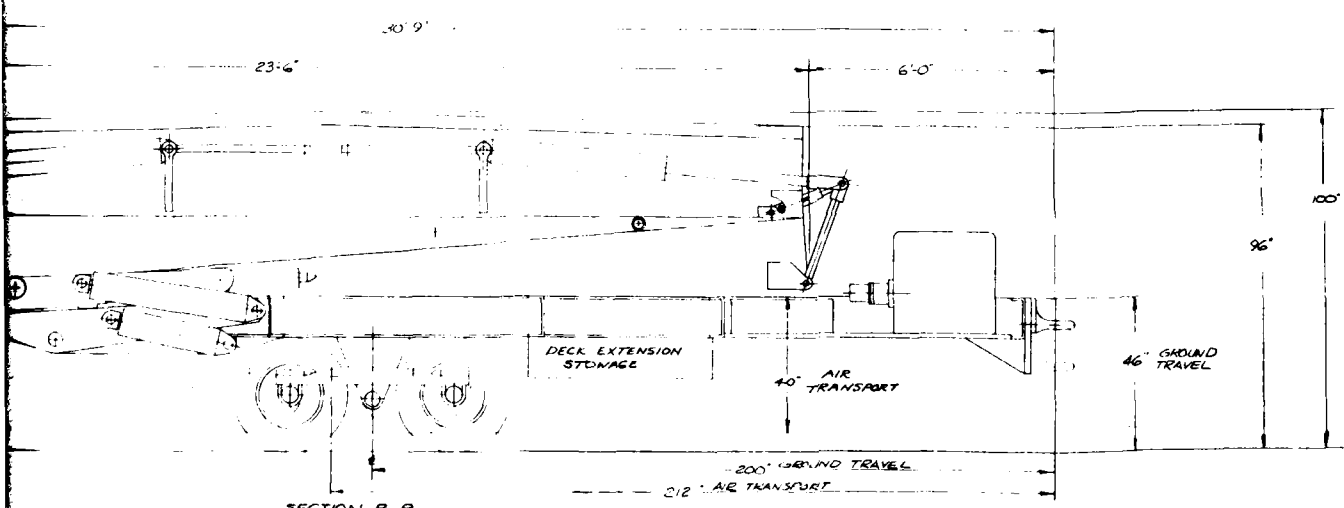
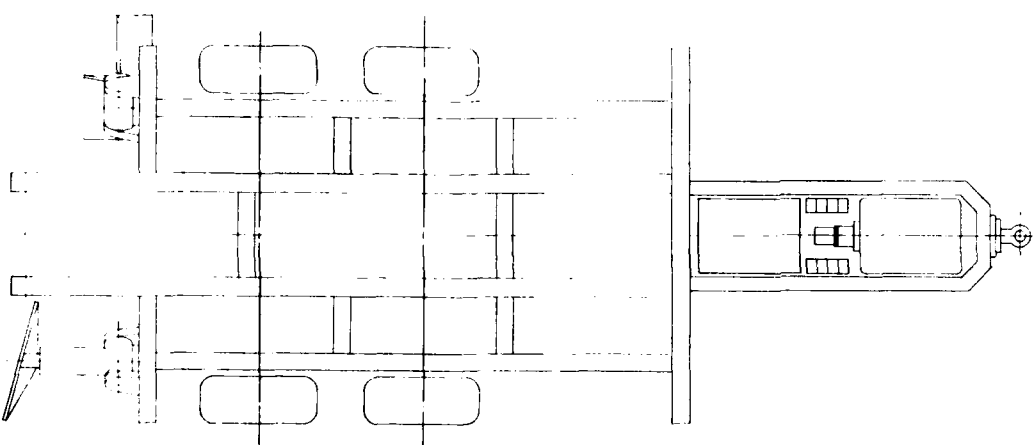

SECTION B-B

VIEW A

E 4193-012

REV.	DATE	DESCRIPTION	BY	CHKD.

DESIGNER CHECKED DATE DRAWN DATE	PROJECT NO. SHEET NO. TITLE	APPROVED DATE	LIST OF PARTS Arthur D Little Inc. CLASS 30 ASSAULT BRIDGE PRELIMINARY DESIGN TASK III (1) DOUBLE SCISSORS BRIDGE SHEET NO. E 75629 4193-012 SCALE 1/4" = 1'-0"
--	-----------------------------------	------------------	--

5

4

3

2

1

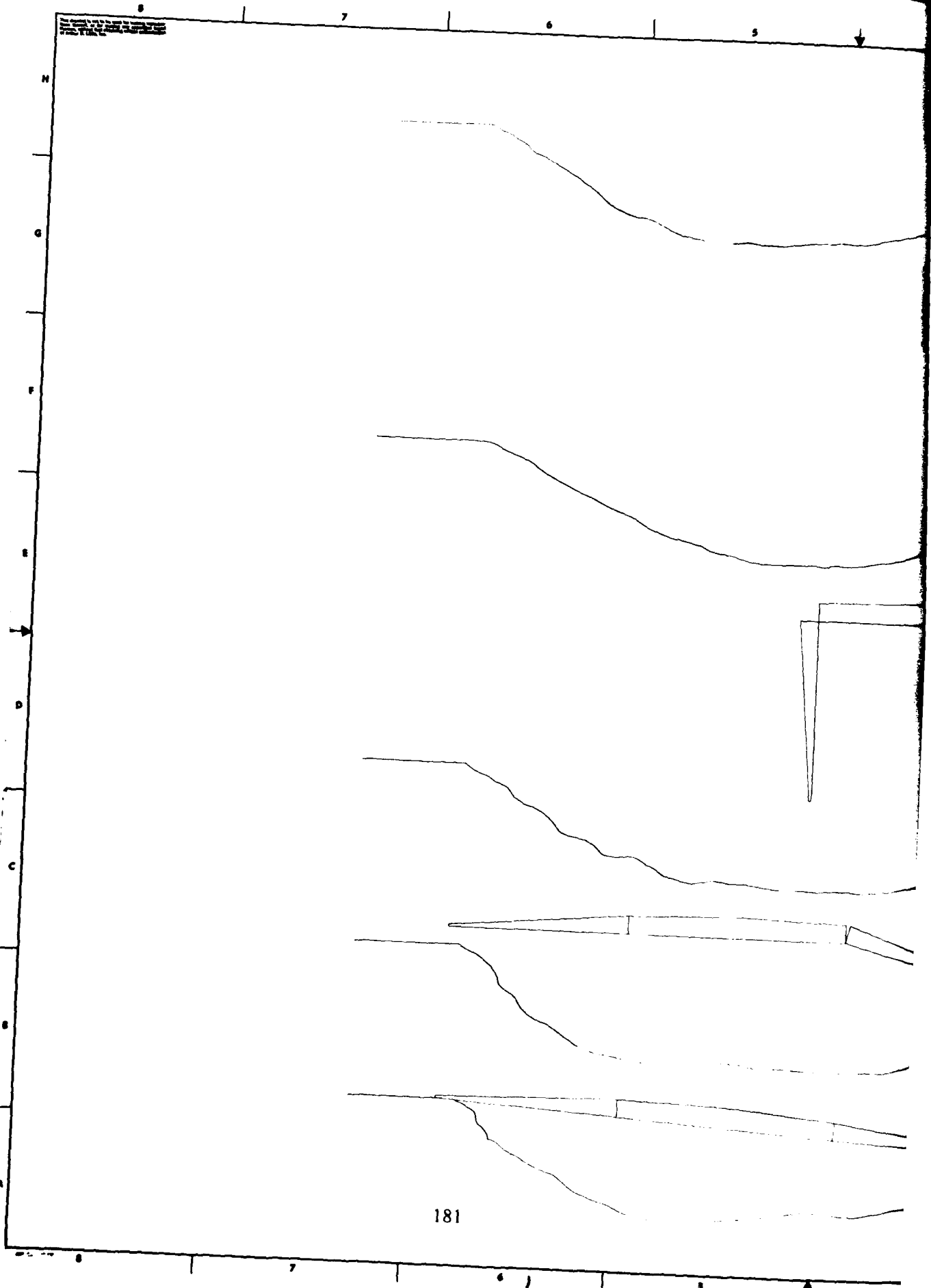

181

5

4

3

2

REVISION	DATE APPROVED



TRAILER IS POSITIONED

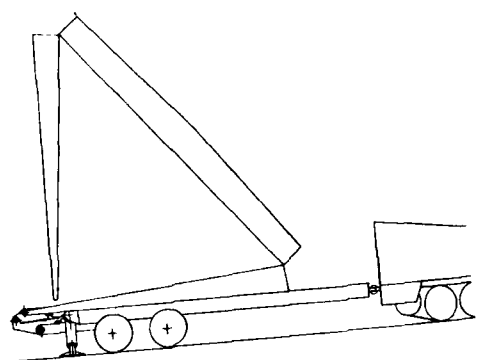

OUTRIGGERS ARE DEPLOYED
BRIDGE PARTIALLY ELEVATED

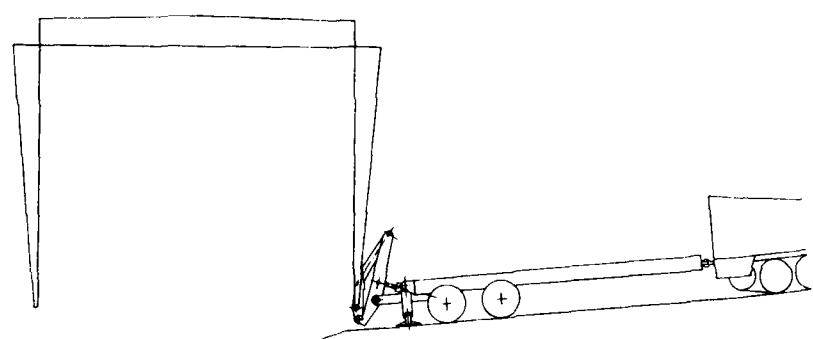

BRIDGE IS ELEVATED + PARTIALLY UNFOLDED

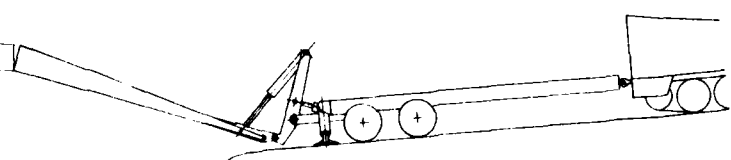

BRIDGE IS PARTIALLY UNFOLDED + LOWERED



BRIDGE IS FULLY EXTENDED + SET DOWN

M

G

F

E

D

C

B

A

10-6627

TITLE: CLASS 30 ASSAULT BRIDGE PRELIMINARY DESIGN TASK III C1 DOUBLE SCISSORS BRIDGE		Arthur D Little Inc. 75629 4193-012	
PROJECT NO: 06618-01 DRAWING NO: 4193-012	DATE: 10/27/81	SCALE: AS SHOWN	SHEET NO: 1 OF 1

2

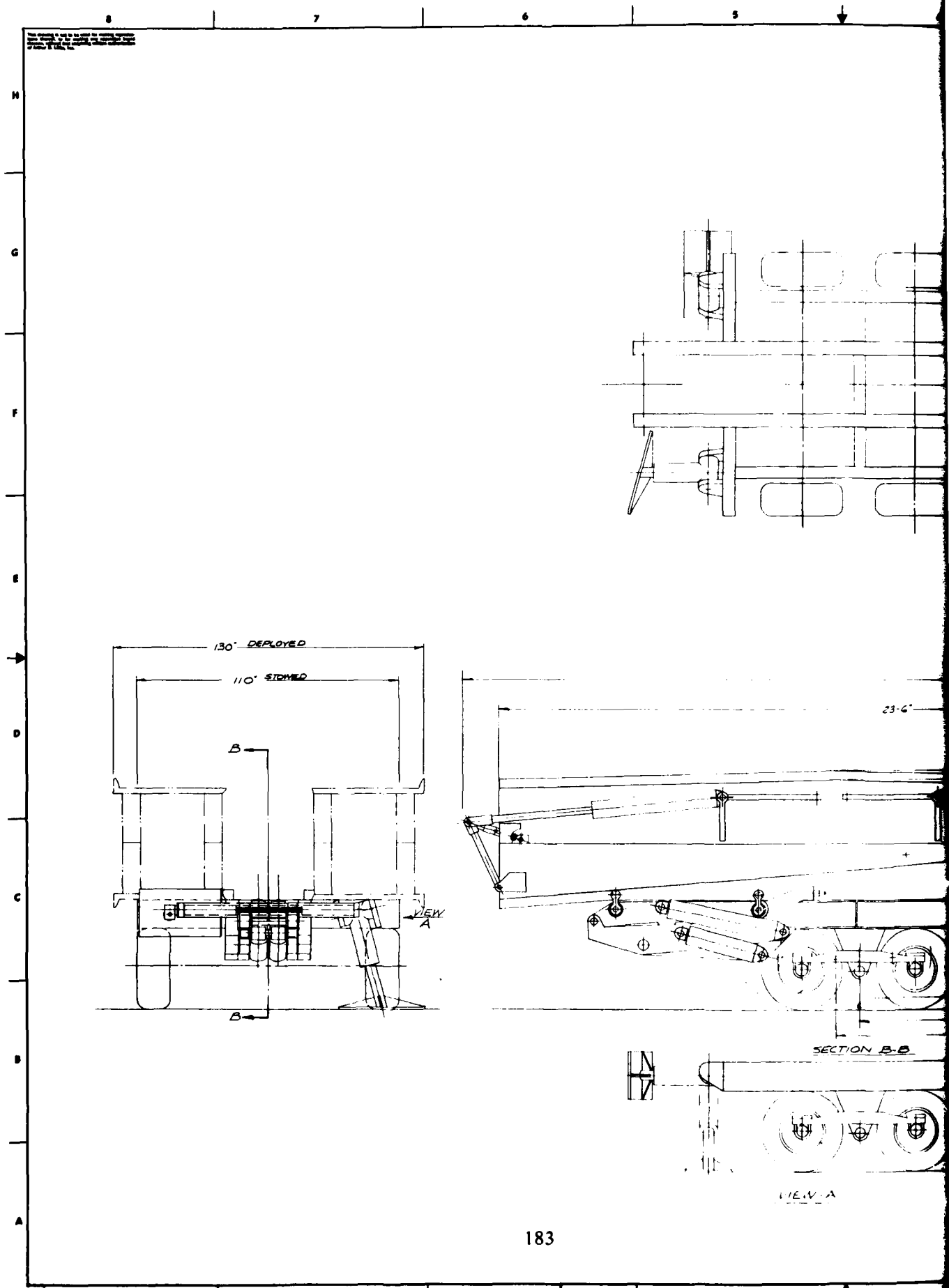

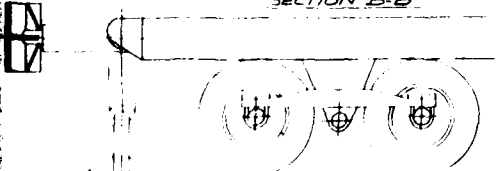
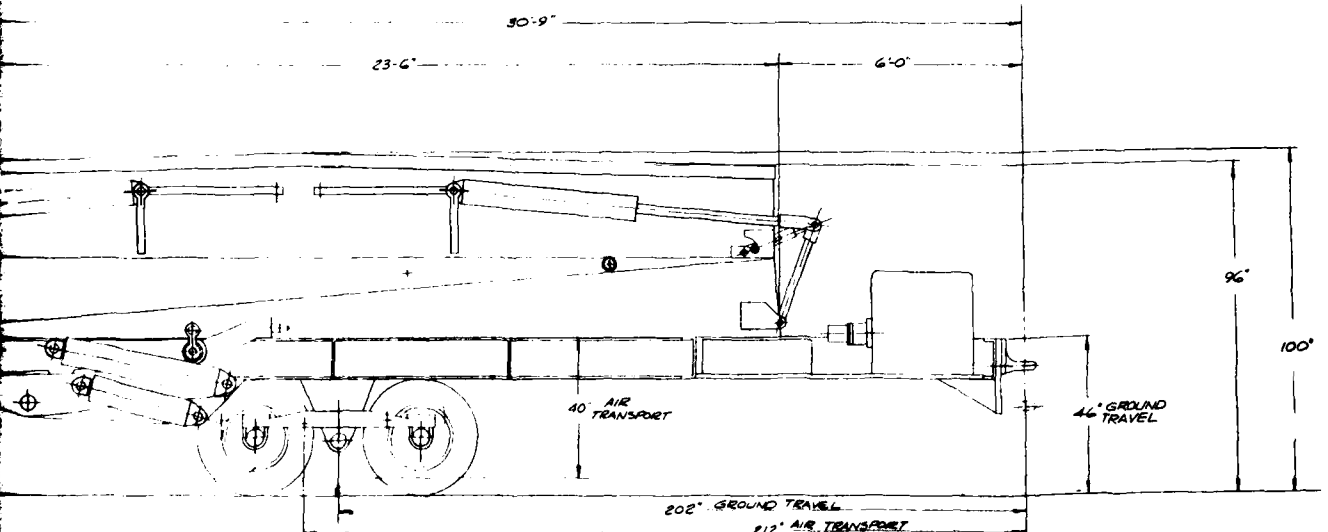
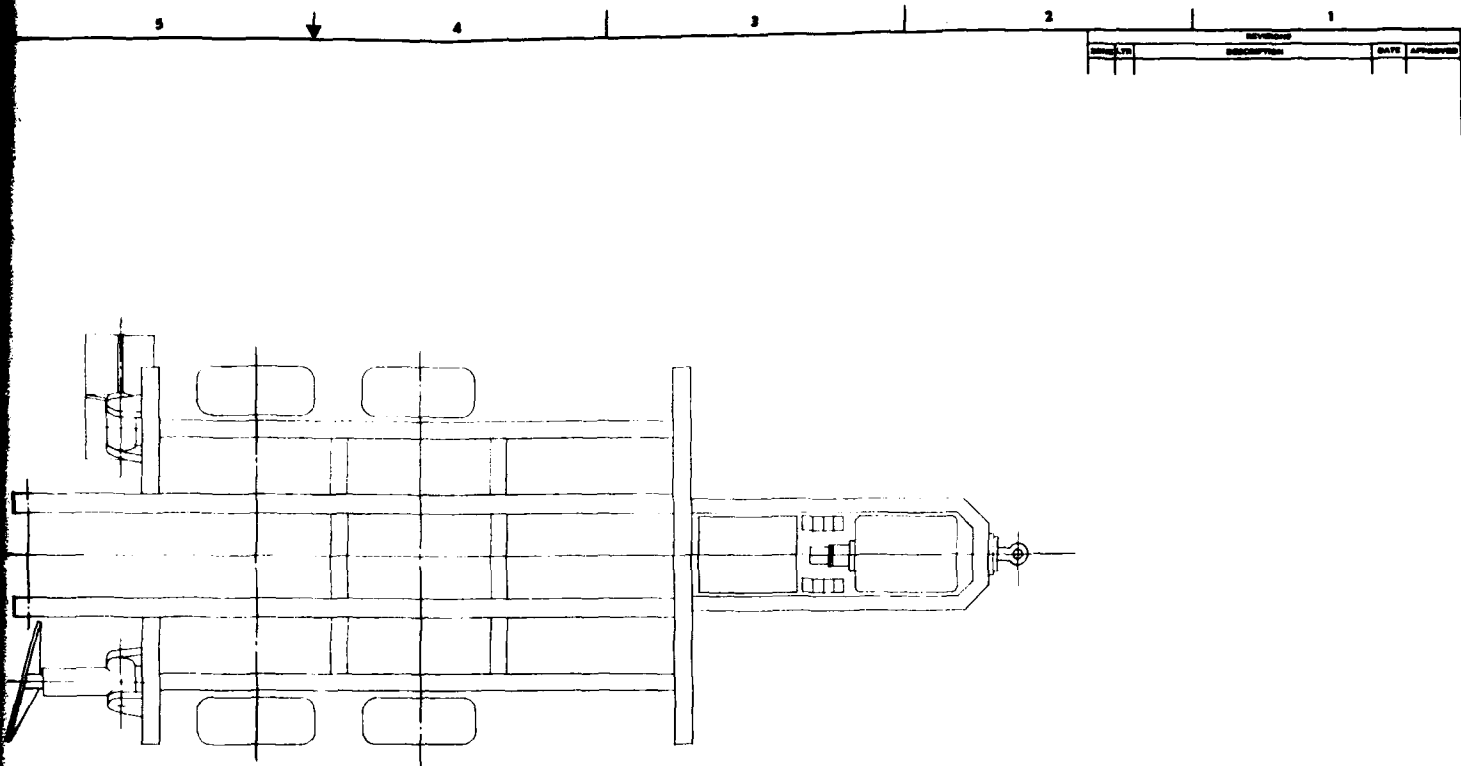

VIEW A

SECTION B-B

REV.	DESCRIPTION	DATE	APPROVED

E 493-013

REV.		DESCRIPTION		DATE		APPROVED	

DESIGNER DRAWN BY CHECKED BY DATE DO NOT SCALE THIS DRAWING TYPED BY APPLICATION	NAME NUMBER DATE PROJECT DRAWING NO. SHEET NO.	LIST OF PARTS Arthur D Little Inc CLASS 30 ASSAULT BRIDGE PRELIMINARY DESIGN TASK III C. DOUBLE SCISSORS BRIDGE E 75629 4193-013 06010-01
--	---	---

2



Arthur D Little, Inc.

Corporate headquarters
Cambridge, Massachusetts

Brussels
London
Madrid
Paris
Rio de Janeiro
San Francisco
São Paulo
Tokyo
Toronto
Washington
Wiesbaden

This drawing is not to be used for making reproductions thereof, or for making any apparatus based thereon, without first obtaining written authorization of Arthur D. Little, Inc.

H

G

F

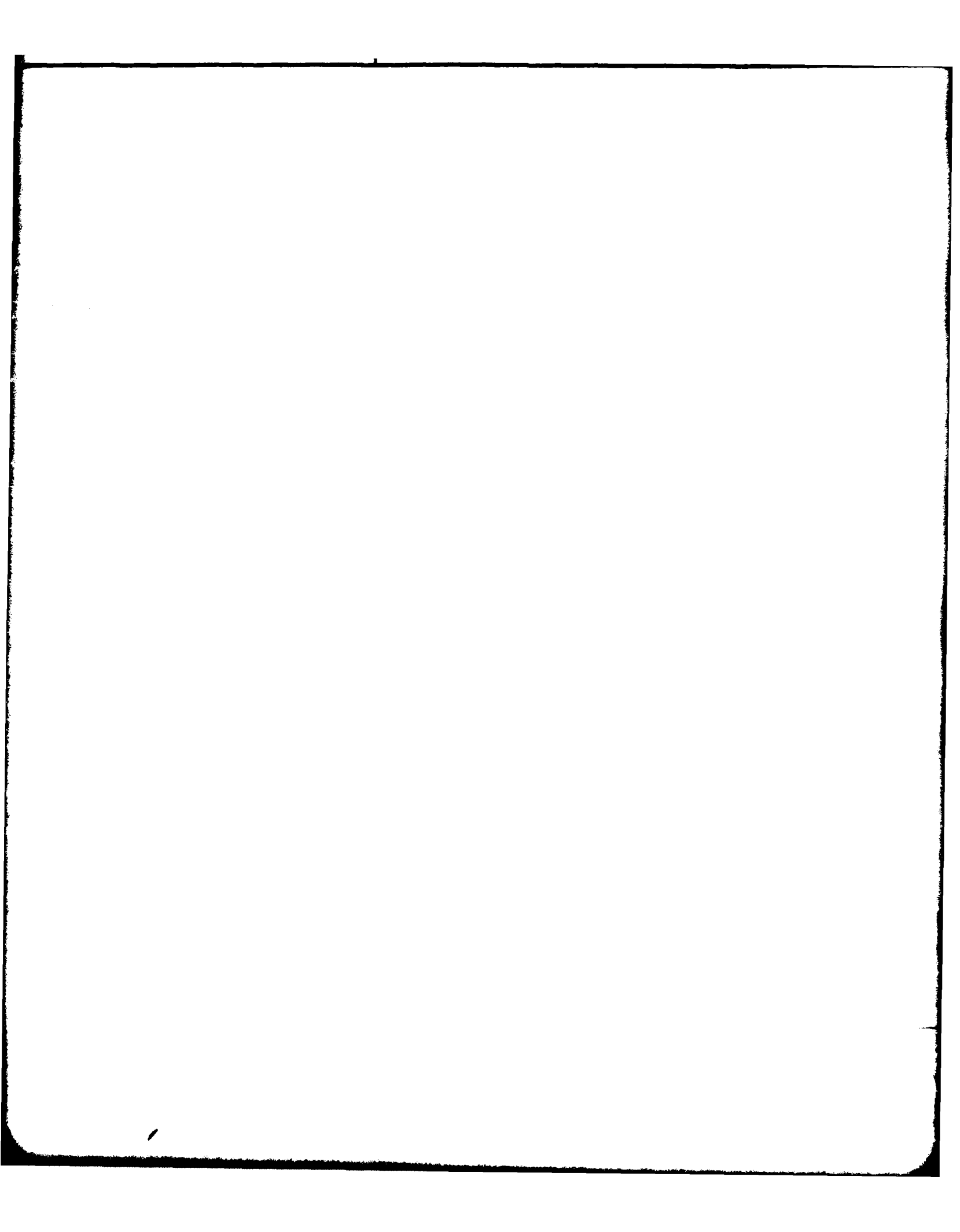

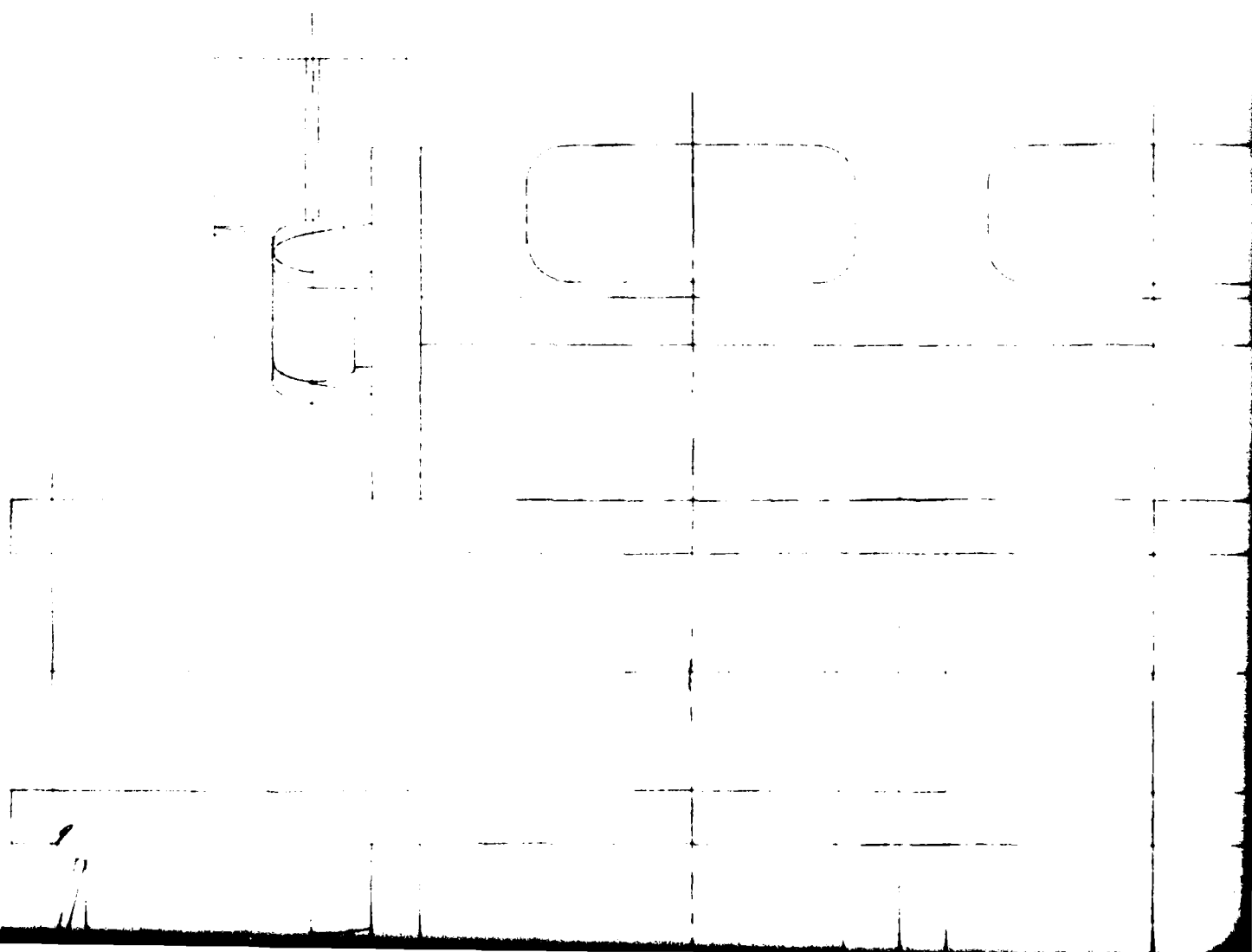

REVISIONS

ZONE LTR

DESCRIPTION

--	--	--



2

5

|

11

6

REVISIONS

ZONE	LTR	DESCRIPTION	DATE	APPROVED

H

G

F

F

7

0

E



D

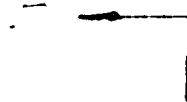

8

9

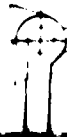
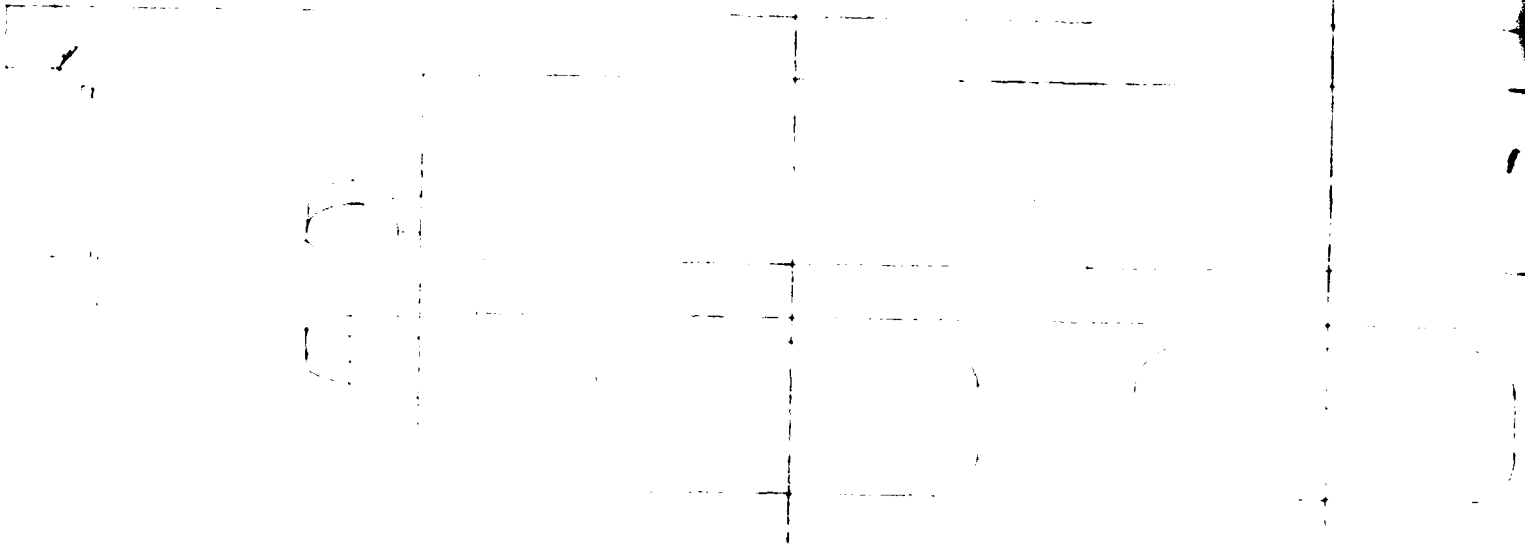

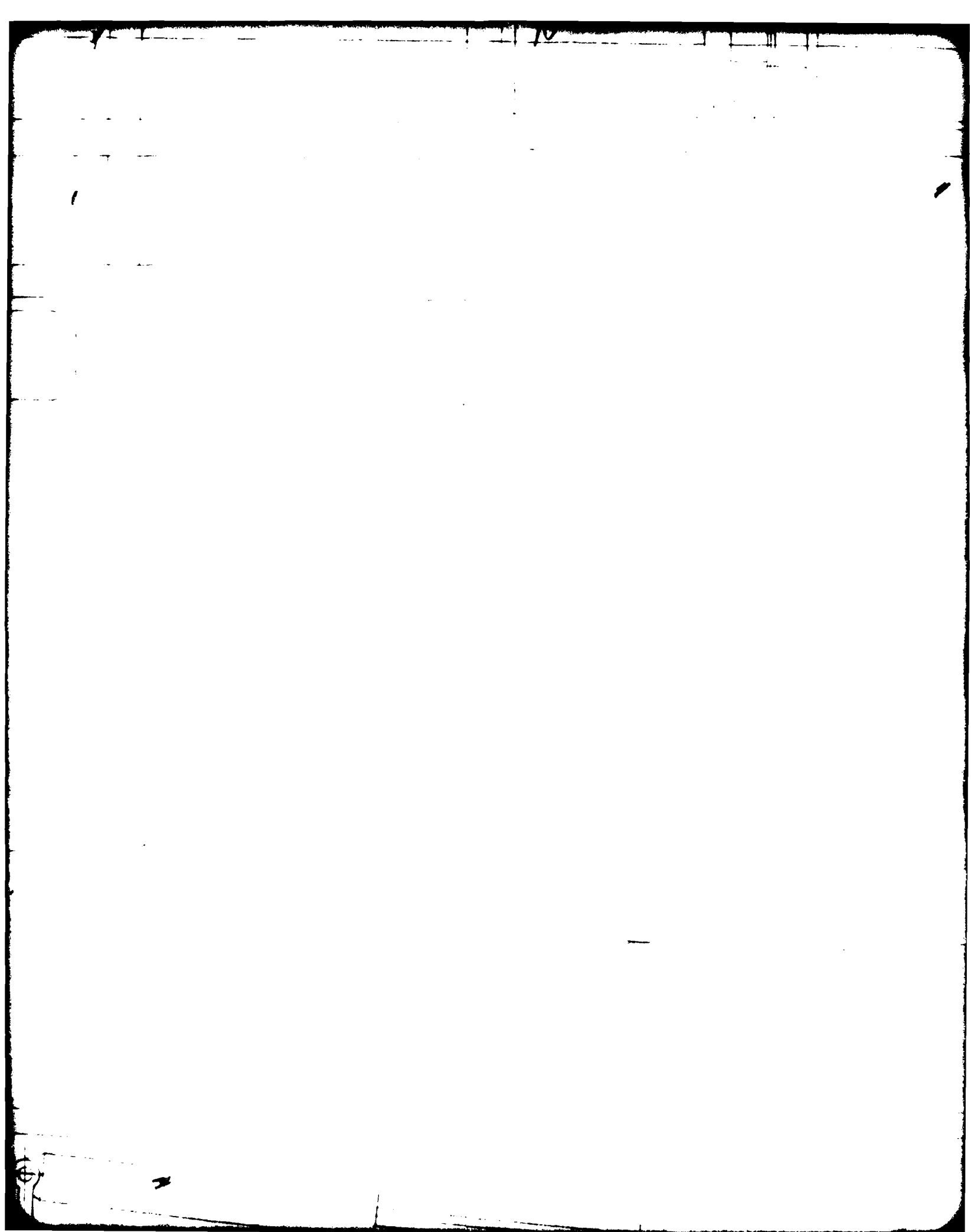

11

1

1

7

1

1

11

11

12

F

E

D



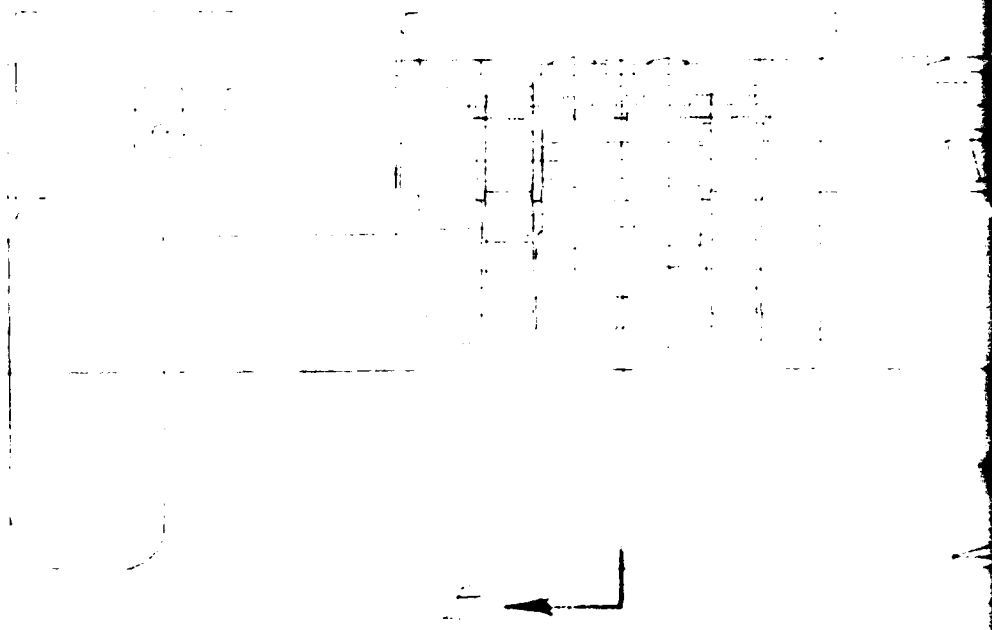

40

13

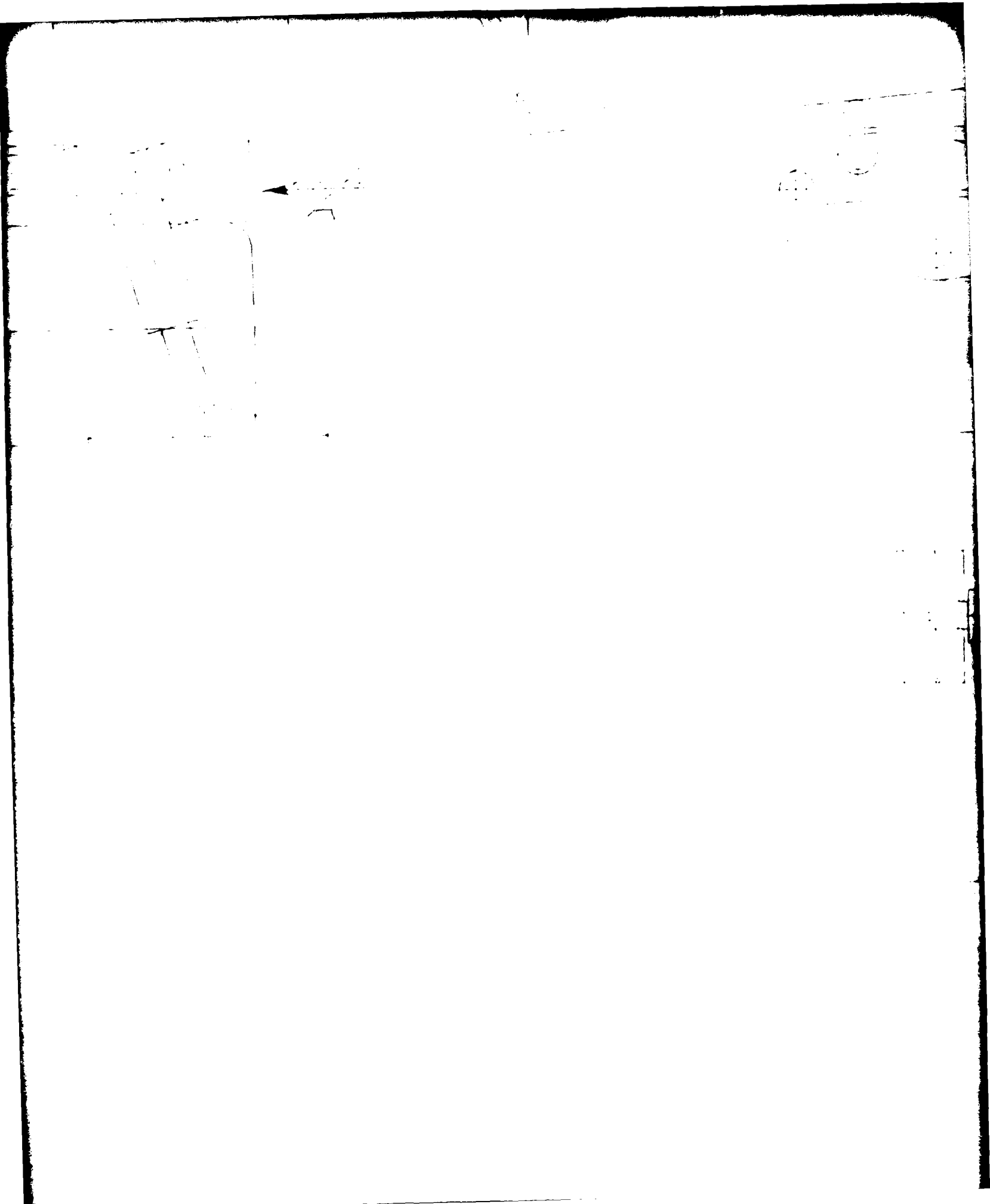

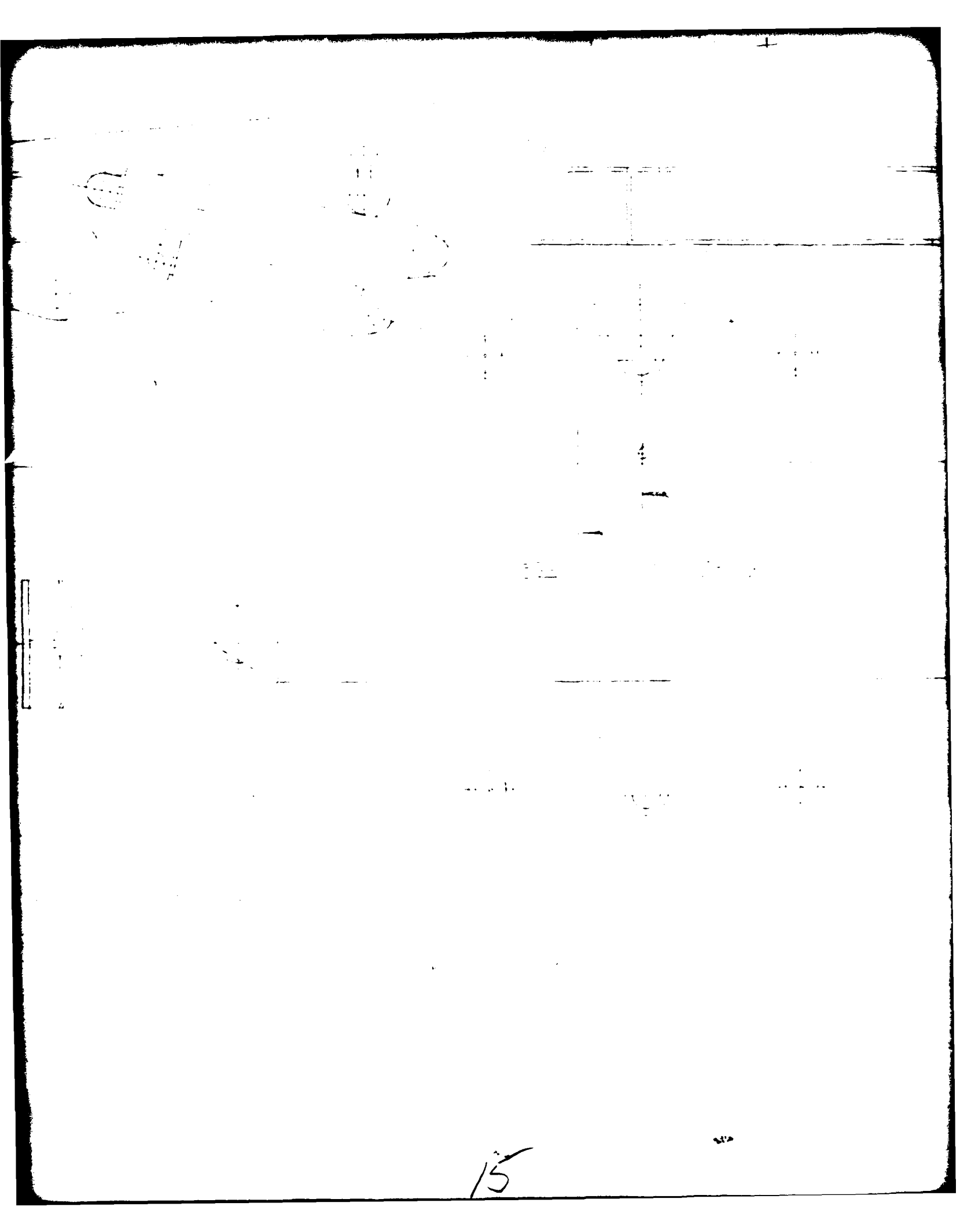

15

NEXT ASSY	USED ON
APPLICATION	

10

SECTION
THRU

ITEM NO.	QTY REQ	PART OR IDENTIFYING NO.	NOMENCLATURE OR DESCRIPTION
LIST OF PARTS			

UNLESS OTHERWISE SPECIFIED		ISSUE DATE:			Art CAMB
DIMENSIONS ARE IN INCHES TOLERANCES:		DRAWN			
DECIMAL .XX = ±.010 .XXX = ±.005	FRACTIONAL ±1/64	CHECKED		5 17	
	ANGULAR ±1°	APPROVED			
FINISHED SURFACES RMS BREAK SHARP CORNERS					
DO NOT SCALE THIS DRAWING					
MATERIAL				SIZE E	CODE IDENT NO. 75629
USED ON		CASE			-17
ON				SCALE	

200
100

Handwritten notes or scribbles at the top left of the page.

REV. 1

B

QTY REQ	PART OR IDENTIFYING NO.	NOMENCLATURE OR DESCRIPTION	MATERIAL
------------	----------------------------	--------------------------------	----------

LIST OF PARTS

	ISSUE DATE:		 <p data-bbox="991 1480 1412 1543">Arthur D. Little, Inc.</p> <p data-bbox="999 1543 1404 1575">CAMBRIDGE, MASSACHUSETTS 02140</p>		
	DRAWN				
MAL	CHECKED				
AR	APPROVED				
S					
		SIZE	CODE IDENT NO.	DRAWING NO.	REVISION
	CASE	E	75629	-17 3.5	
		SCALE			SHEET

A

2

17

1

Handwritten mark or signature at the bottom right.

8

7

This drawing is not to be used for making reproductions thereof, or for making any apparatus based thereon, without first obtaining written authorization of Arthur D. Little, Inc.

H

G

d

1

2

6

4

5

3



4

4

5

4

FILED

30F



AD
A115 131

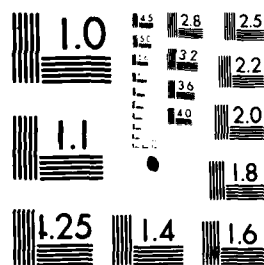

MICROCOPY RESOLUTION TEST CHART
NATIONAL BUREAU OF STANDARDS-1963-A

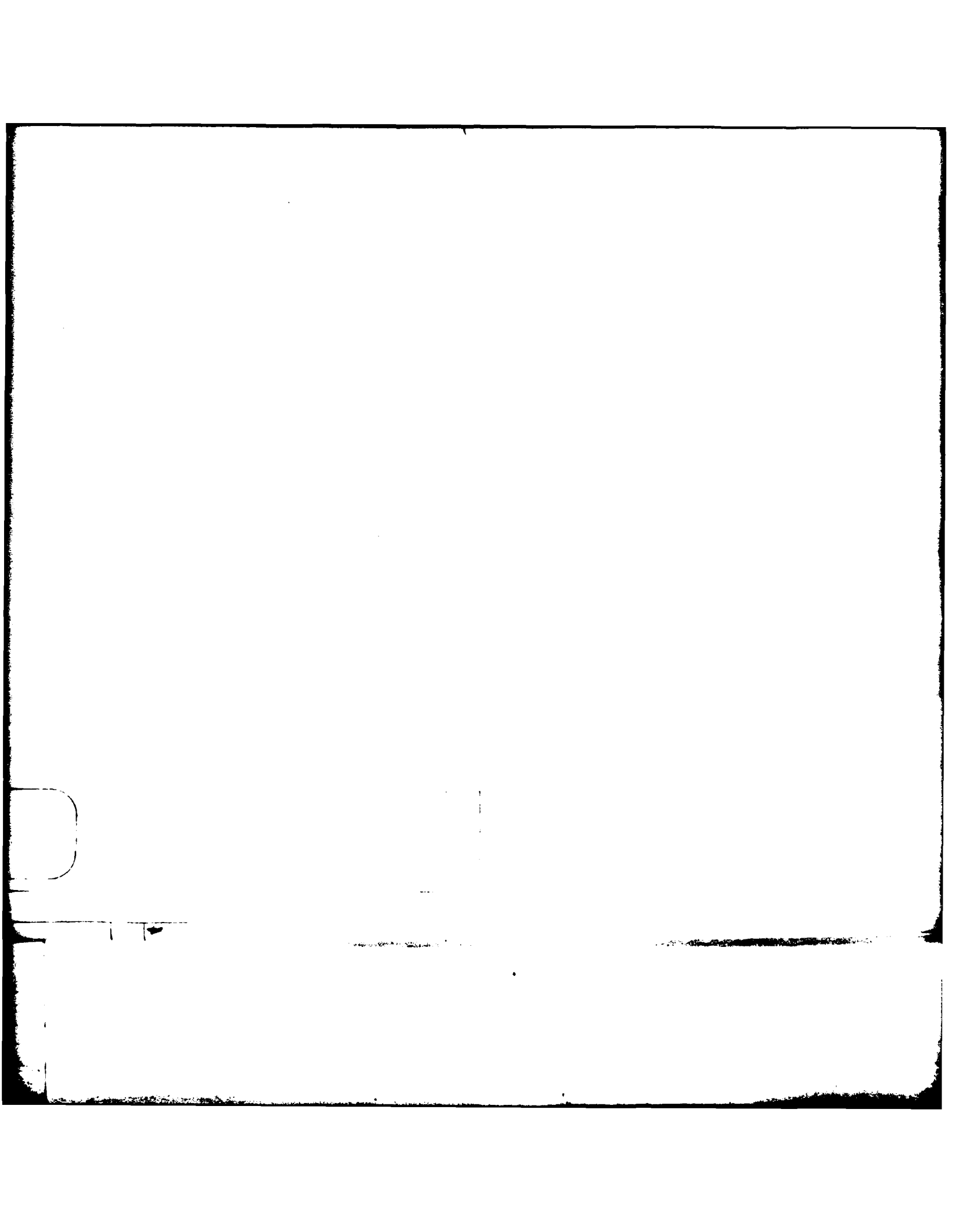

REVISIONS

ZONE LTR

DESCRIPTION

--	--

REVISIONS

ZONE	LTR	DESCRIPTION	DATE	APPROVED

G

↓

7

F

E



8

2

1

7
7

1-1-1

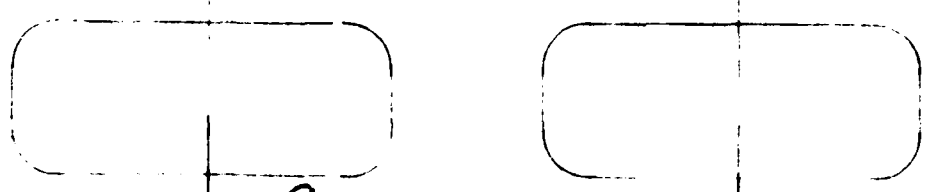

9

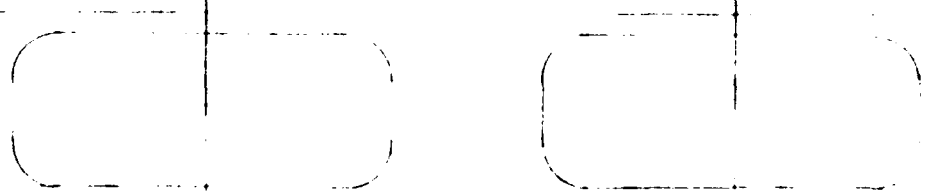

A

10

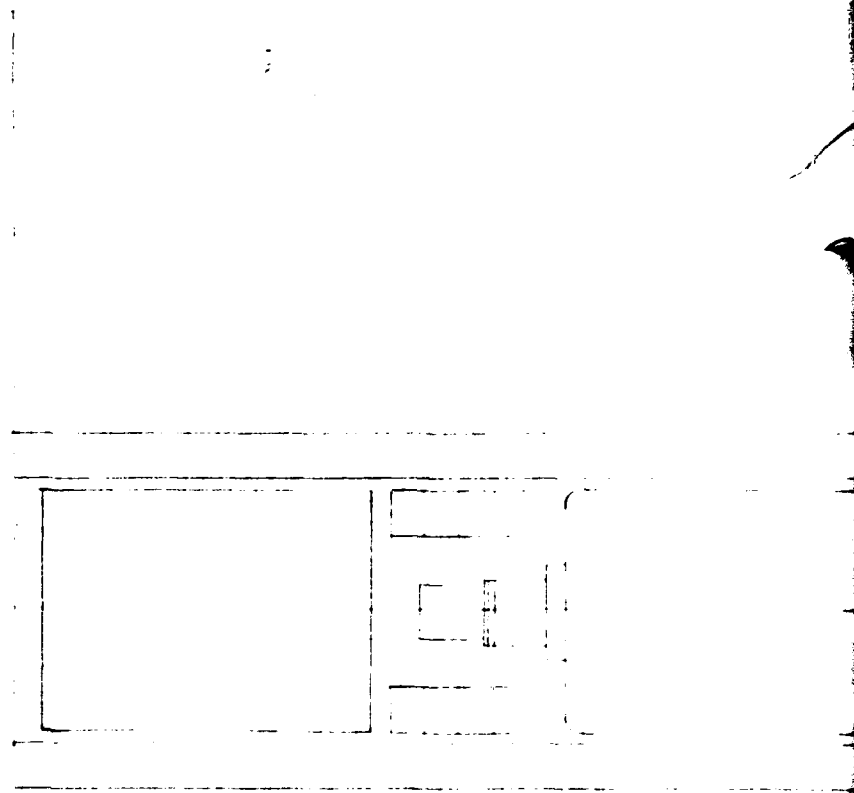



A

13



D

100 200 300

STONES

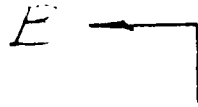

C

57

19

14

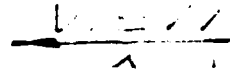
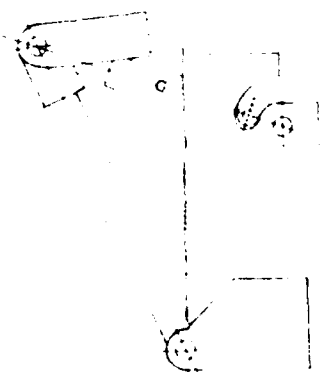

1

v

15

M

29

7

16



17

18

D

C

B

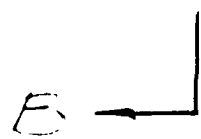

A

ADL-221-478-1M

8

19

7

90"

SECTION 1-5

VIEW 1-5

STORAGE

40° AIR
TO AIRFOOT

NEXT ASSY	USED ON
APPLICATION	

1
2
3
4
5
6
7
8
9
10

76

ITEM NO.	QTY REQ	PART OR IDENTIFYING NO.	NOMENCLATURE OR DESCRIPTION
----------	---------	-------------------------	-----------------------------

LIST OF PARTS

UNLESS OTHERWISE SPECIFIED		ISSUE DATE:		 Arthur <small>RIDGE</small>	
DIMENSIONS ARE IN INCHES TOLERANCES:		DRAWN			
DECIMAL .XX = ± .010 .XXX = ± .005	FRACTIONAL ± 1/64	CHECKED		<i>Handwritten notes:</i> SS 1/4 TASK...	
FINISHED SURFACES RMS BREAK SHARP CORNERS		APPROVED			
DO NOT SCALE THIS DRAWING					
		SIZE CODE IDENT NO. DRAWING			

46

E
REV.

B

A

QTY REQ	PART OR IDENTIFYING NO.	NOMENCLATURE OR DESCRIPTION	MATERIAL
---------	-------------------------	-----------------------------	----------

LIST OF PARTS

	ISSUE DATE:	 Arthur D. Little, Inc. BRIDGE, MASSACHUSETTS 02140			
DRAWN					
CHECKED					
APPROVED					
BAL AR S S	TASK	TASK			
	CASE	SIZE	CODE IDENT NO.	DRAWING NO.	REVISION
	E	E	75629	4157-522	
		SCALE			SHEET 10-2

2 23

1

24

This drawing is not to be used for making reproductions thereof, or for making any apparatus based thereon, without first obtaining written authorization of Arthur D. Little, Inc.

1
DIFFICULTY
- ALL THE
- THE

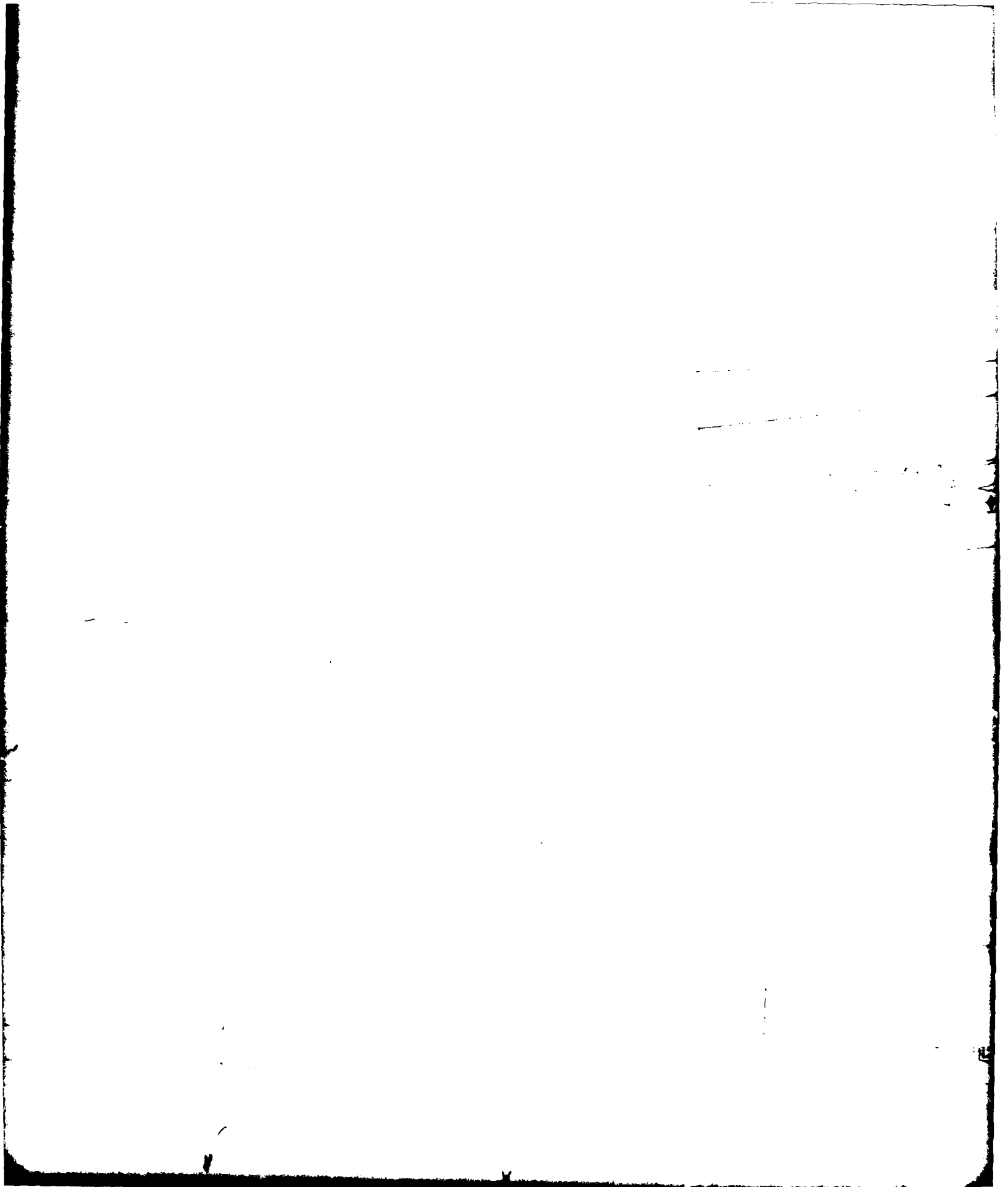

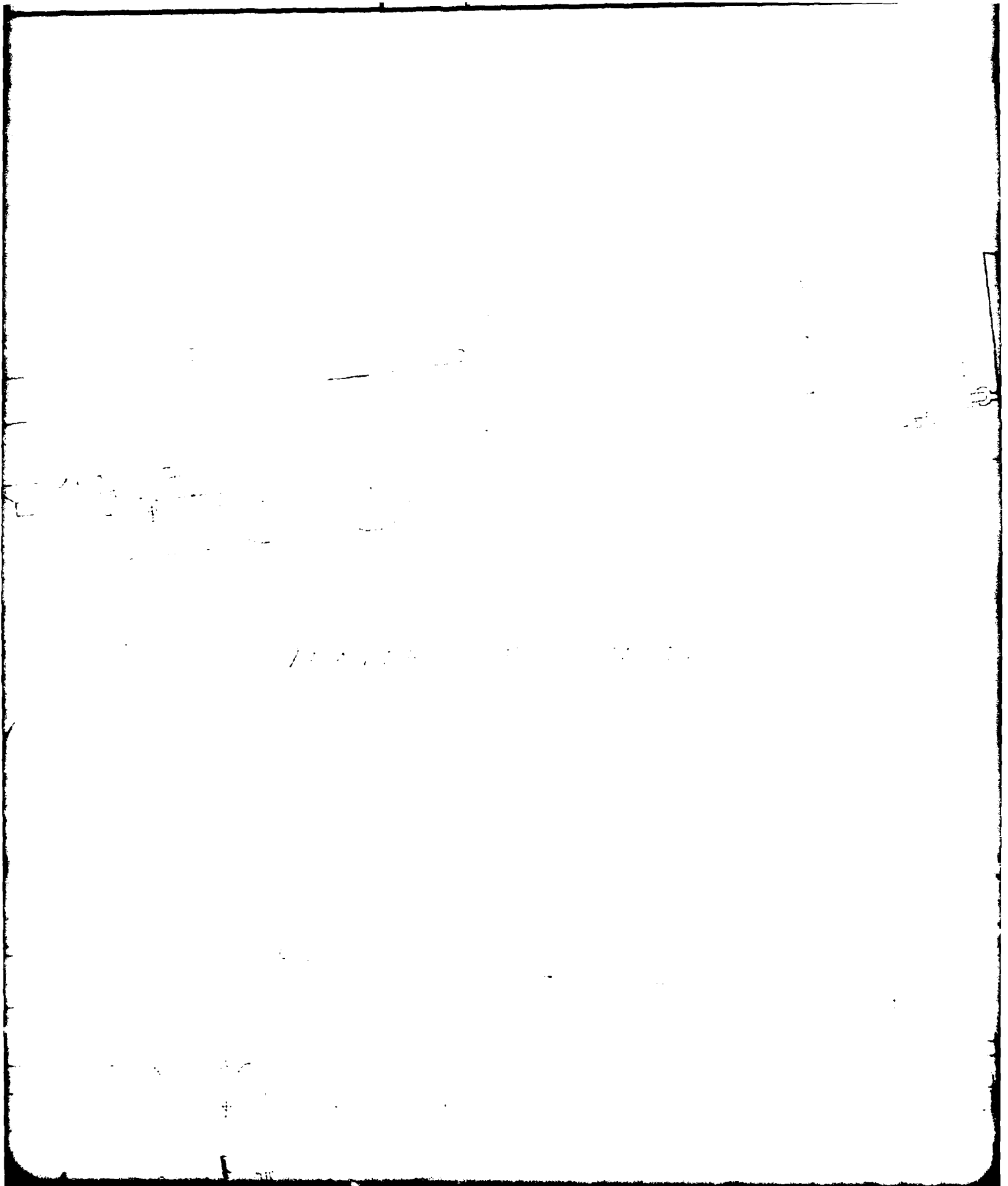

REVISIONS

ZONE LTR

DESCRIPTION

--	--

--

2

5

|

11

6

REVISIONS

ZONE	LTR	DESCRIPTION	DATE	APPROVED

F



E



D

1
1

2000
1000
1000
1000

1

9

380
10

THE UNIVERSITY OF CHICAGO
LIBRARY
540 EAST 57TH STREET
CHICAGO, ILL. 60637

THE UNIVERSITY OF CHICAGO
LIBRARY

1

11

11

11

11

E



11

12

C

B

A

17

1

1

1

8

10

1

1000

BRIDGE NAME ARE EXTENDING SOUTH

16

SECTION 12

D

C

E

4102 211

REV.

12

C

B

A

7

6 19

5

↑ 20

4

3111 RETRACT
3111

UNLESS OTHERWISE SPECIFIED

DIMENSIONS ARE IN INCHES
TOLERANCES:

DECIMAL
.XX = ± .010
.XXX = ± .005

FINISHED SURFACES
BREAK SHARP CORNERS

DO NOT SCALE THIS DRAWING

NEXT ASSY	USED ON
APPLICATION	

MATERIAL

ITEM NO.	QTY REQ	PART OR IDENTIFYING NO.	NOMENCLATURE OR DESCRIPTION	MATERIAL
----------	---------	-------------------------	-----------------------------	----------

LIST OF PARTS

UNLESS OTHERWISE SPECIFIED		ISSUE DATE:		 Arthur D. Little CAMBRIDGE, MASSACHUSETTS			
DIMENSIONS ARE IN INCHES TOLERANCES:		DRAWN				<i>Checked by [Signature]</i> <i>Approved by [Signature]</i> <i>DATE [Date]</i>	
DECIMAL XX = ± .010 XX = ± .005	FRACTIONAL ± 1/64 ANGULAR ± 1°	CHECKED		APPROVED			
FINISHED SURFACES RMS SHARP CORNERS							
DO NOT SCALE THIS DRAWING							
MATERIAL		CASE		SIZE E	CODE IDENT NO. 75629 DRAWING NO. +123 011		

C

E
4-20-51
REV.

B

A

QTY REQ	PART OR IDENTIFYING NO.	NOMENCLATURE OR DESCRIPTION	MATERIAL
------------	----------------------------	--------------------------------	----------

LIST OF PARTS

	ISSUE DATE:	 Arthur D. Little, Inc. CAMBRIDGE, MASSACHUSETTS 02140	
	DRAWN		
MAL	CHECKED	<i>Checked by [unclear] 12-11-51</i> <i>Approved by [unclear]</i> <i>TASK [unclear]</i> <i>DATE [unclear]</i>	
LAR	APPROVED		
MS			
		SIZE E	CODE IDENT NO. 75629
	CASE 25215	DRAWING NO. +122 311	REVISION
		SCALE 1/4" = 1"	SHEET 2 of 3

8

N

7

This drawing is not to be used for making reproductions thereof, or for making any apparatus based thereon, without first obtaining written authorization of Arthur D. Little, Inc.

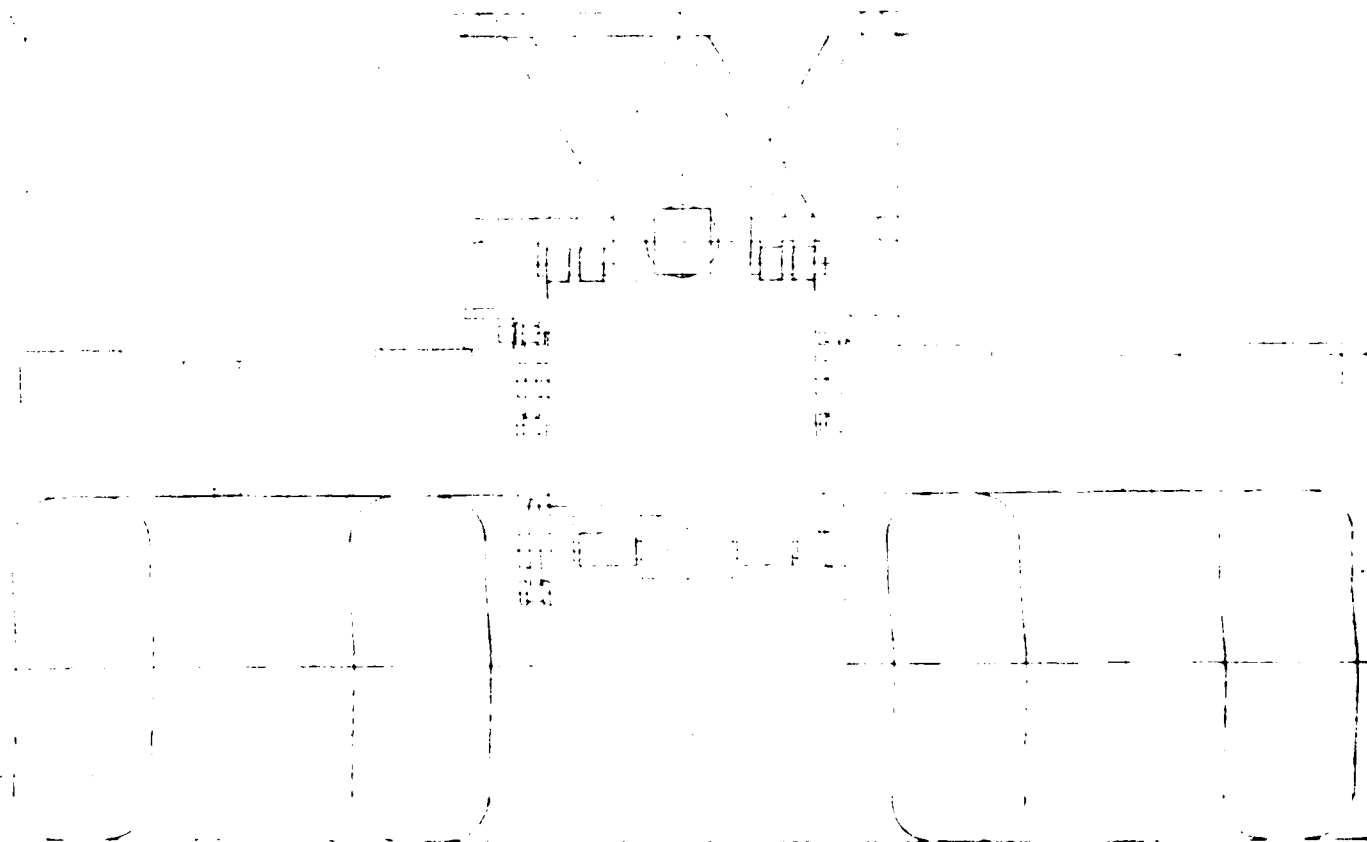

SECTION D-D

A.C.

1

2

6

44 215 100
44 100 100

9

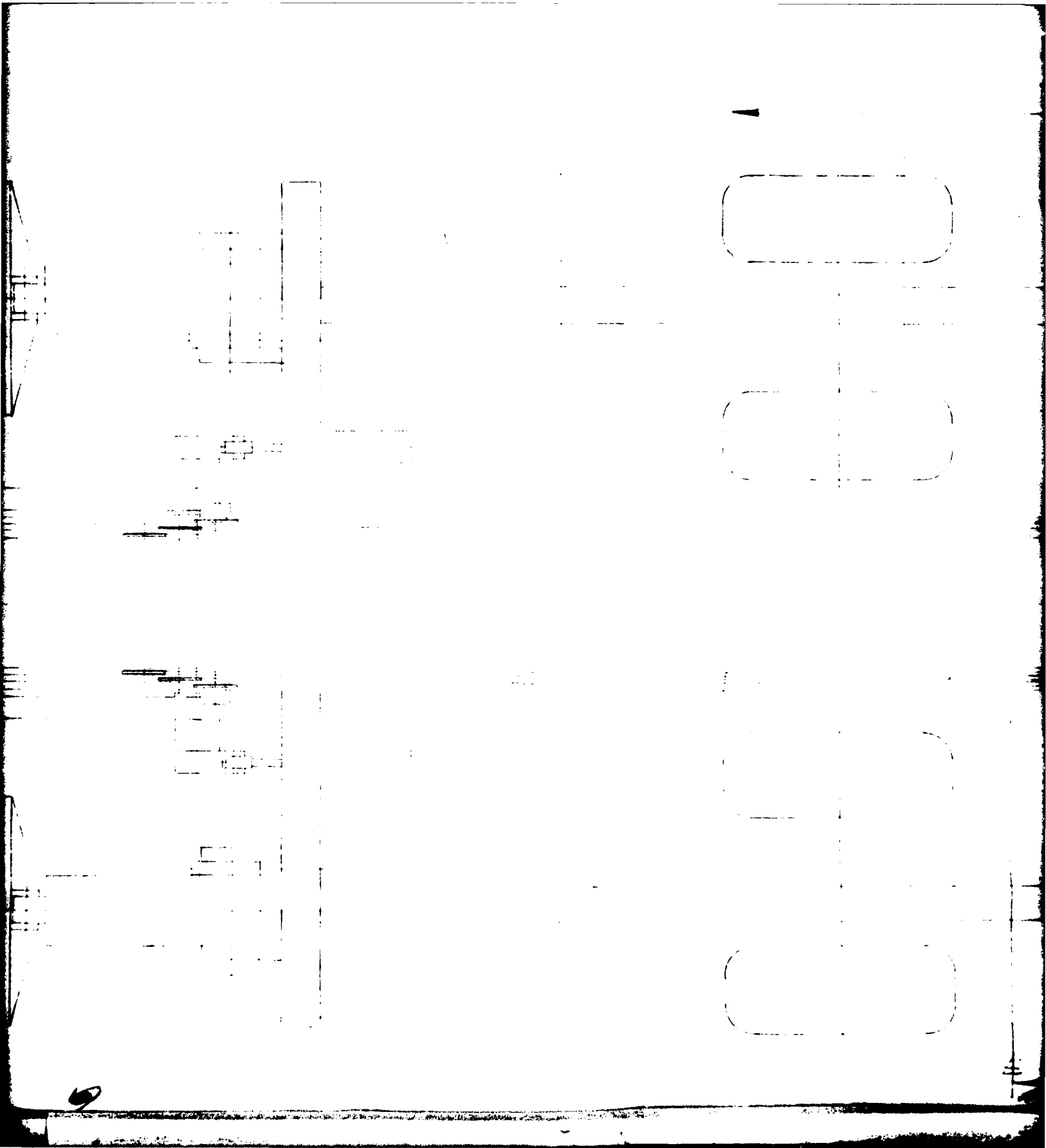

305 AIR TRANSPORT

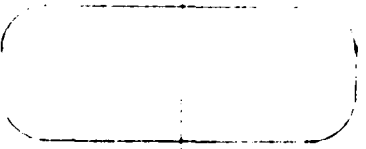
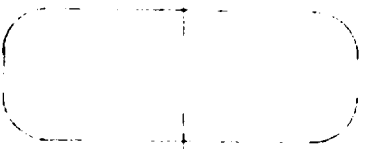
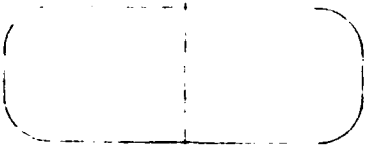

305 AIR TRANSPORT

1

2

5

1

REVISIONS

ZONE LTR

DESCRIPTION

DATE



2

5

1

6

REVISIONS

ZONE	LTR	DESCRIPTION	DATE	APPROVED

H

G

F

9

SECTION D-D

A/C
TRAIL

F

E

D

A



GROUND TRAIL

8

8

A
↑
—

1877

9

1877

1

1

1877

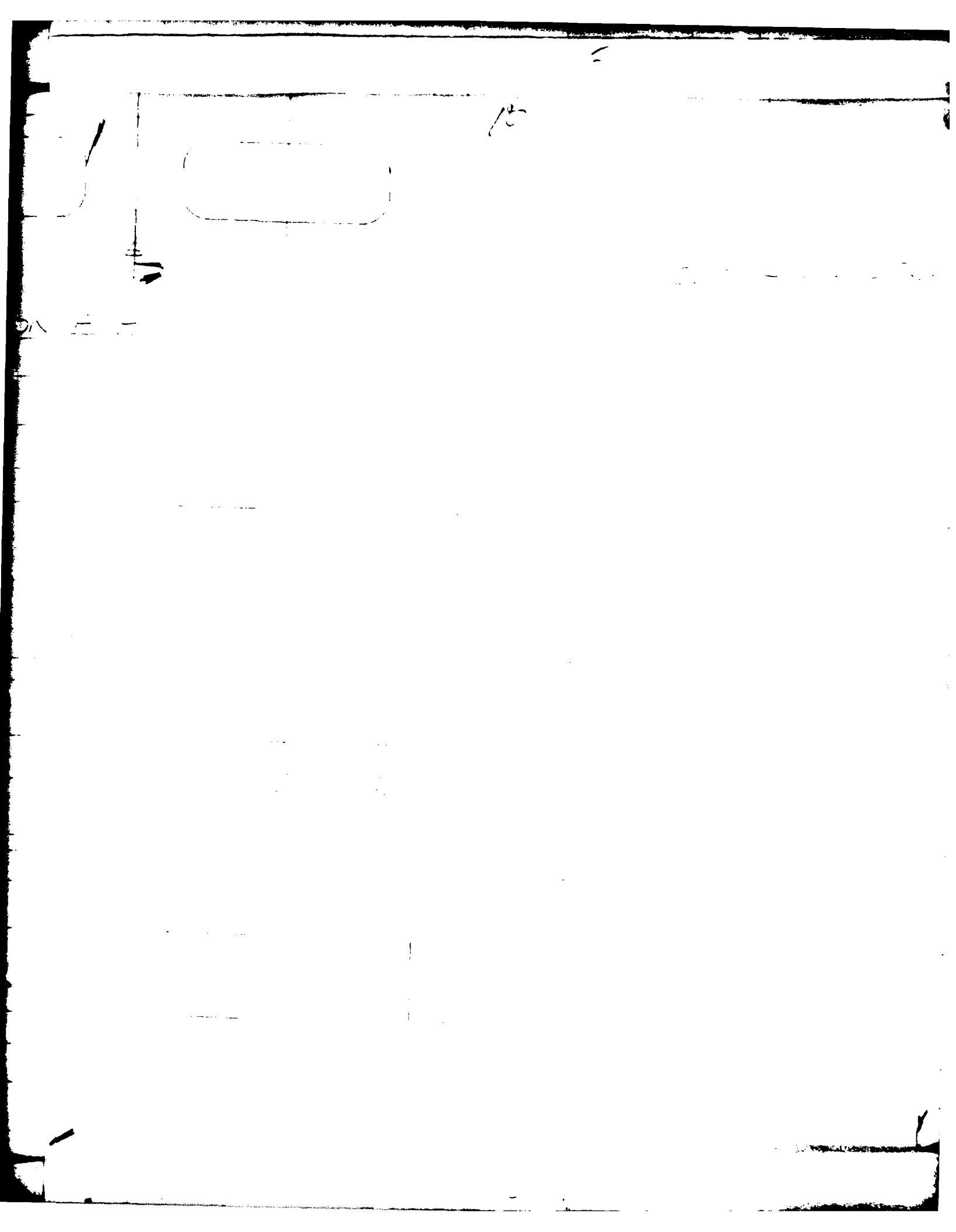

11

11

4

11

11

11

12

F

E

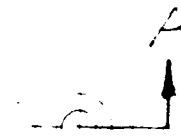

D
A
C
R

125'
GAS...
AIR...

B



SECTION

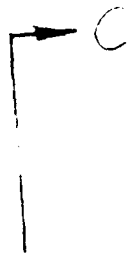

RAMP JUNE 24

p

1

1

D

A

D

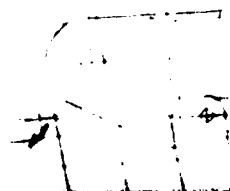
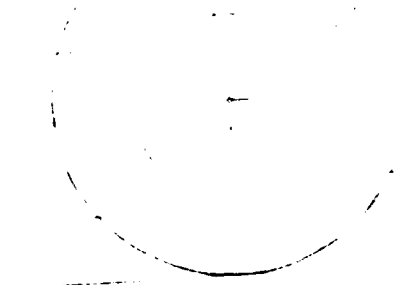

41-3

22-6

DECK PLANNING
STOWAGE

SECTION 100

D

C

E

4/30/11

REV.

B

11

5

11

11

11

11

C

B

B

SECTION 5-5

OUTSIDE STRIP

A

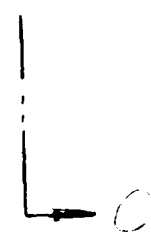
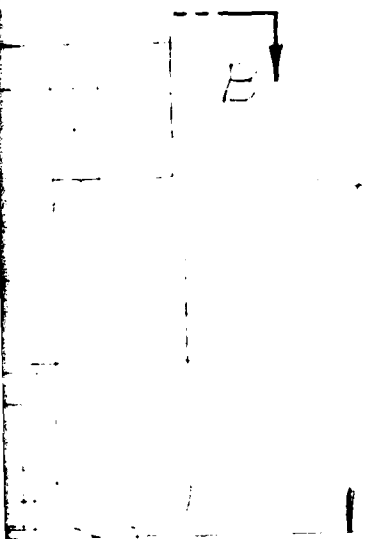

RAMP INSIDE

A N

CS
11/20

12

1



68
MAX.

35
MAX.

1

5

2!



DISCONTINUED
STORAGE

NEXT ASSY	USED ON
APPLICATION	

2507-1-1

ITEM NO.	QTY REQ	PART OR IDENTIFYING NO.	NOMENCLATURE OR DESCRIPTION
----------	---------	-------------------------	-----------------------------

LIST OF PARTS

UNLESS OTHERWISE SPECIFIED		ISSUE DATE:		
DIMENSIONS ARE IN INCHES TOLERANCES:		DRAWN <i>2/1/57</i>		
DECIMAL .XX = ±.010 .XXX = ±.005	FRACTIONAL ±1/64	CHECKED		<i>2507-1-1</i>
	ANGULAR ±1°	APPROVED		
FINISHED SURFACES RMS				
BREAK SHARP CORNERS				
DO NOT SCALE THIS DRAWING				
MATERIAL		SIZE	CODE IDENT NO.	
USED ON		E	75629	
APPLICATION		CASE <i>50019-3</i>	SCALE <i>3/4"</i>	

23 **2**

C

E
1
REV.

B

A

PART OR IDENTIFYING NO.	NOMENCLATURE OR DESCRIPTION	MATERIAL
-------------------------	-----------------------------	----------

LIST OF PARTS

ISSUE DATE:		 Arthur D Little, Inc. CAMBRIDGE, MASSACHUSETTS 02140
DRAWN	24/001-	
CHECKED		
APPROVED		
CASE		SIZE CODE IDENT NO. DRAWING NO. REVISION E 75629 4123-011
SCALE		SHEET 1-3

2

1

24

8

7

This drawing is not to be used for making reproductions thereof, or for making any apparatus based thereon, without first obtaining written authorization of Arthur D. Little, Inc.

H

G

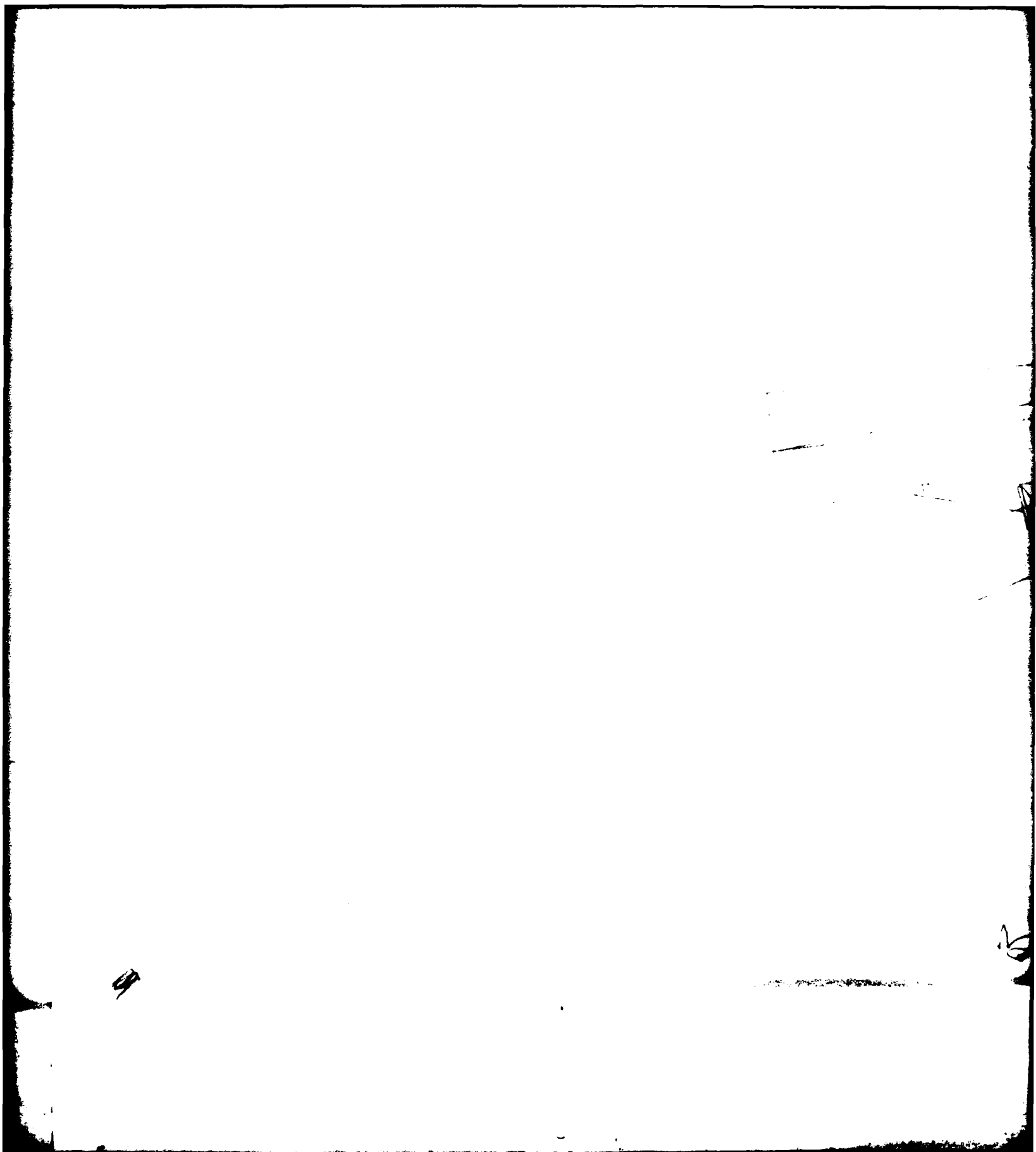

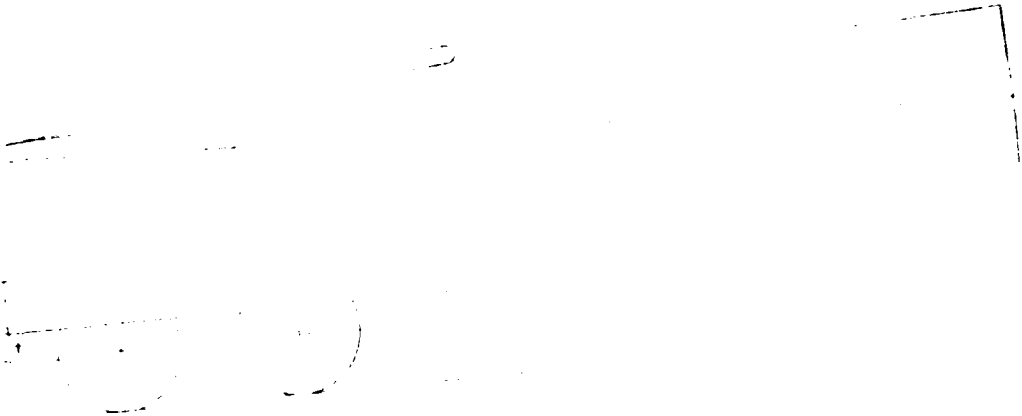

TRANSFORMER

6/29

REVISIONS

ZONE LTR

DESCRIPTION

7

2

5

|

1

1

6

REVISIONS

ZONE	LTR	DESCRIPTION	DATE	APPROVED

H

G

Q

F

—

E



7

1

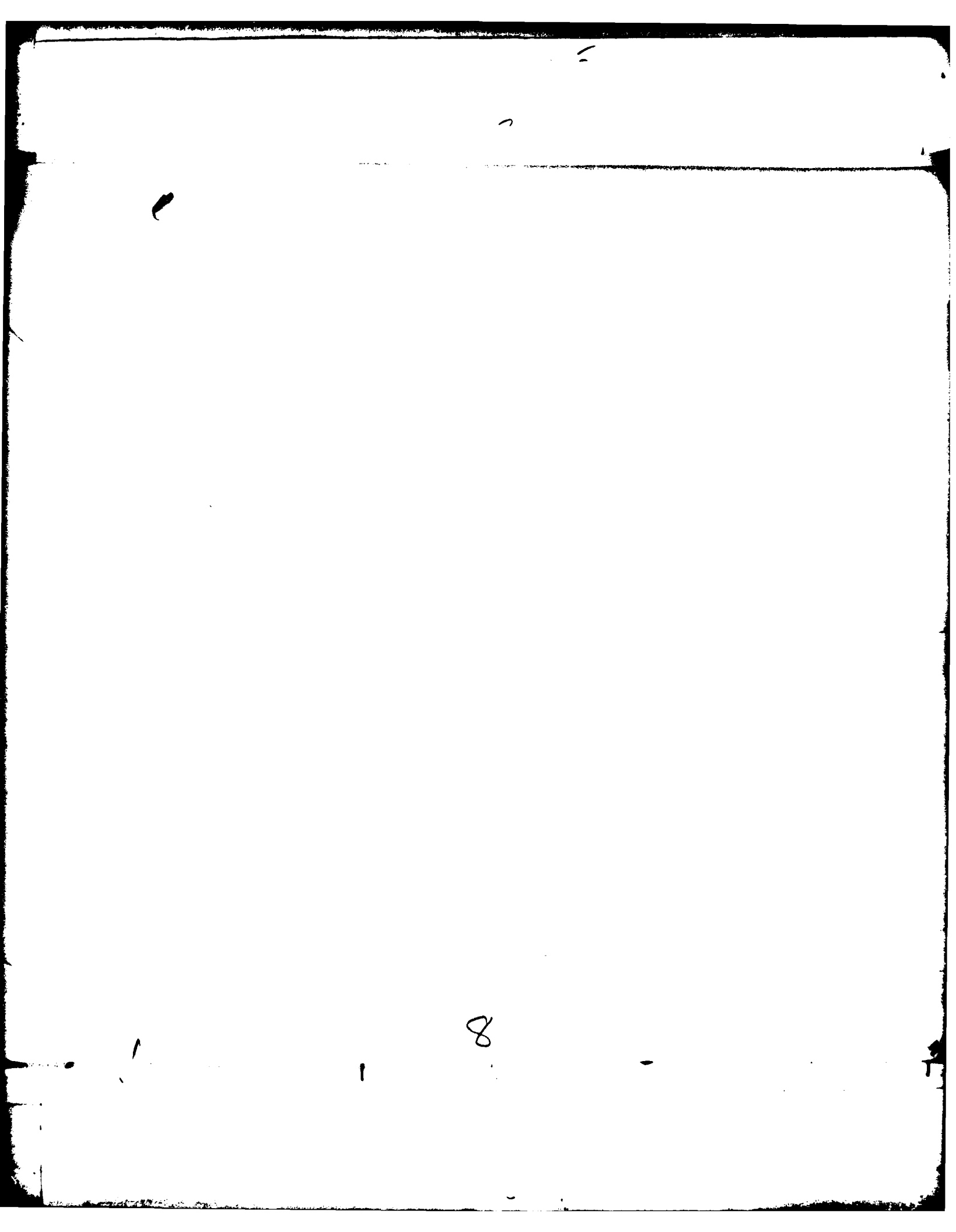

2

2

2

2

9

2
1

1

12

12
12
12

12
12
12
12
12

10

2

1

1111

LOCAL

1

1

11

F

E

11

1

12

D

1
 2
 3
 4
 5
 6
 7
 8
 9
 10
 11
 12
 13
 14
 15
 16
 17
 18
 19
 20
 21
 22
 23
 24
 25
 26
 27
 28
 29
 30
 31
 32
 33
 34
 35
 36
 37
 38
 39
 40
 41
 42
 43
 44
 45
 46
 47
 48
 49
 50
 51
 52
 53
 54
 55
 56
 57
 58
 59
 60
 61
 62
 63
 64
 65
 66
 67
 68
 69
 70
 71
 72
 73
 74
 75
 76
 77
 78
 79
 80
 81
 82
 83
 84
 85
 86
 87
 88
 89
 90
 91
 92
 93
 94
 95
 96
 97
 98
 99
 100

C

B

1
2
3
4
5
6
7
8
9
10
11
12
13
14
15
16
17
18
19
20
21
22
23
24
25
26
27
28
29
30
31
32
33
34
35
36
37
38
39
40
41
42
43
44
45
46
47
48
49
50
51
52
53
54
55
56
57
58
59
60
61
62
63
64
65
66
67
68
69
70
71
72
73
74
75
76
77
78
79
80
81
82
83
84
85
86
87
88
89
90
91
92
93
94
95
96
97
98
99
100

15

Handwritten text, possibly a signature or date, appearing as faint scribbles.

Vertical handwritten marks or characters.

1

10

1

1

17

1000

17

18

D

C

E

REV. 1/2/70

REV.

A

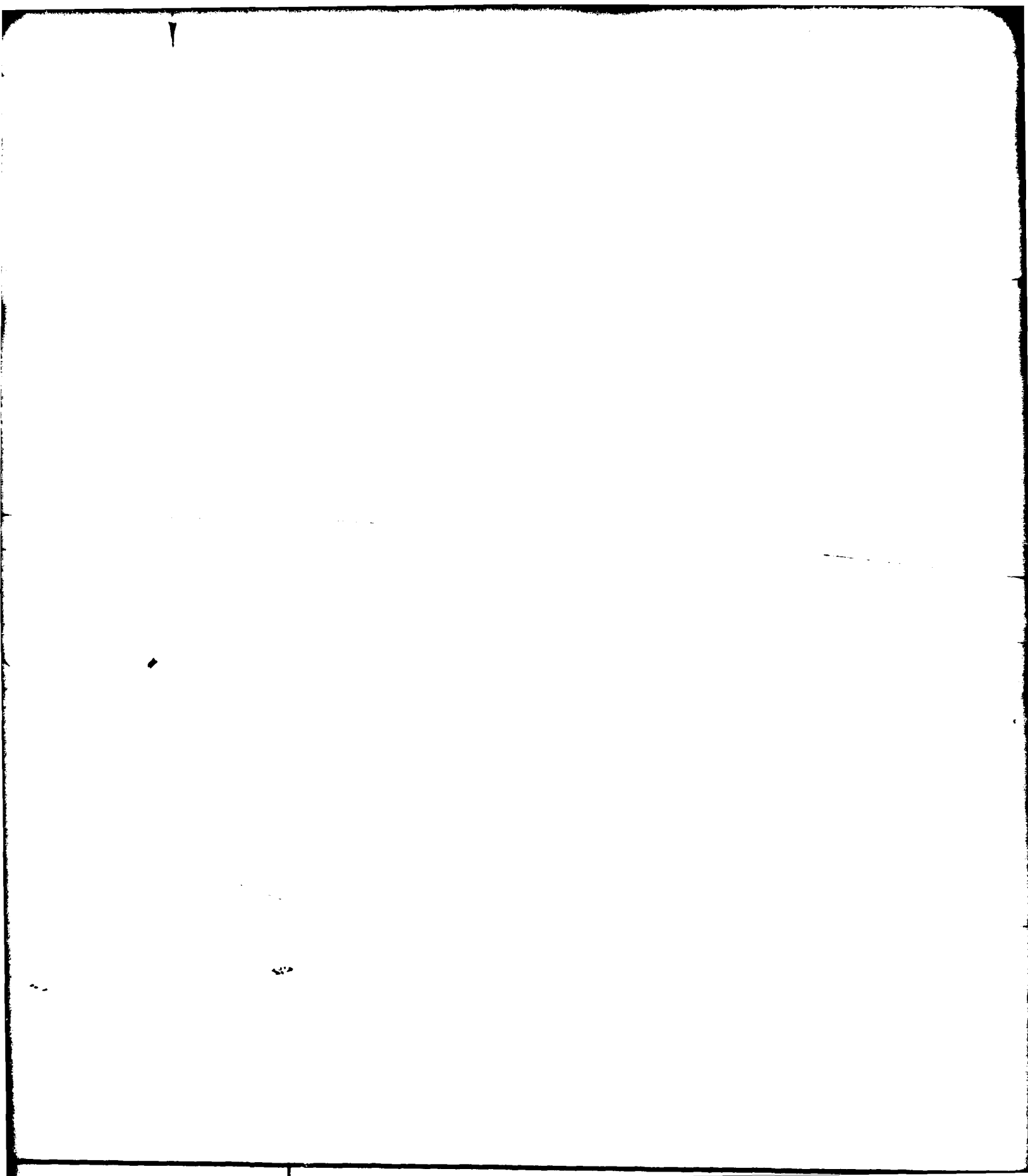

Y
A

2

5

21



4

1

Handwritten text at the top of the page, possibly a title or part number, which is mostly illegible due to fading.

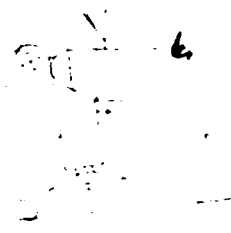

Handwritten text in the middle of the page, likely describing the part or its specifications, but it is very faint and difficult to read.

NEXT ASSY	USED ON
APPLICATION	

UNL
DIMENSIONS & TOLERANCES
DECIMAL .XX = ±.0 .XXX = ±.0
FINISHED SURFACE BREAK SHARP
DO NOT SCALE
MATERIAL

ITEM NO.	QTY REQ	PART OR IDENTIFYING NO.	NOMENCLATURE OR DESCRIPTION
----------	---------	-------------------------	-----------------------------

LIST OF PARTS

UNLESS OTHERWISE SPECIFIED		ISSUE DATE:			Arthur CAMBRIDGE
DIMENSIONS ARE IN INCHES TOLERANCES:		DRAWN <i>10/2</i>			
DECIMAL .XX = ±.010 .XXX = ±.005	FRACTIONAL ±1/64	CHECKED		<i>Approved by D L. M. L. M.</i>	
	ANGULAR ±1°	APPROVED			
FINISHED SURFACES RMS BREAK SHARP CORNERS					
DO NOT SCALE THIS DRAWING					
MATERIAL		CASE <i>806.8-11</i>		SIZE E	CODE IDENT NO. 75629
				SCALE <i>1/4</i>	DRAW <i>4.78</i>

2 *23*

C

E

REV.

B

A

QTY REQ	PART OR IDENTIFYING NO.	NOMENCLATURE OR DESCRIPTION	MATERIAL
---------	-------------------------	-----------------------------	----------

LIST OF PARTS

	ISSUE DATE:	 Arthur D. Little, Inc. CAMBRIDGE, MASSACHUSETTS 02140			
	DRAWN				
AL	CHECKED	<i>APPROVED BY LITTLE</i> <i>REVISION 24 11 1950</i> <i>LA...</i>			
R	APPROVED				
		SIZE	CODE IDENT NO.	DRAWING NO.	REVISION
	CASE	E	75629	4795-010	
	85679-11	SCALE 1/4"		SHEET	24

2

23

1

24

8

7

This drawing is not to be used for making reproductions thereof, or for making any apparatus based thereon, without first obtaining written authorization of Arthur D. Little, Inc.

H

G

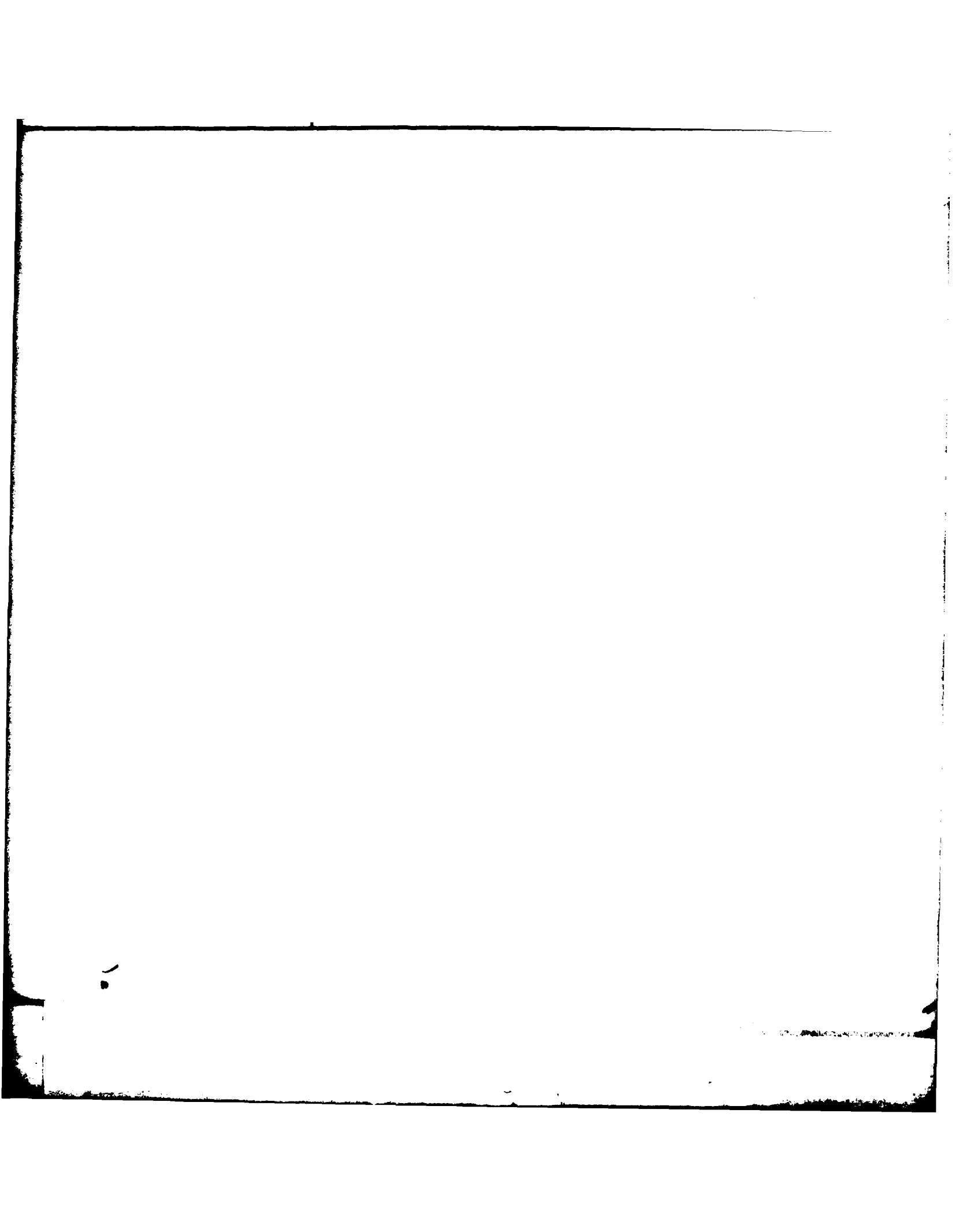

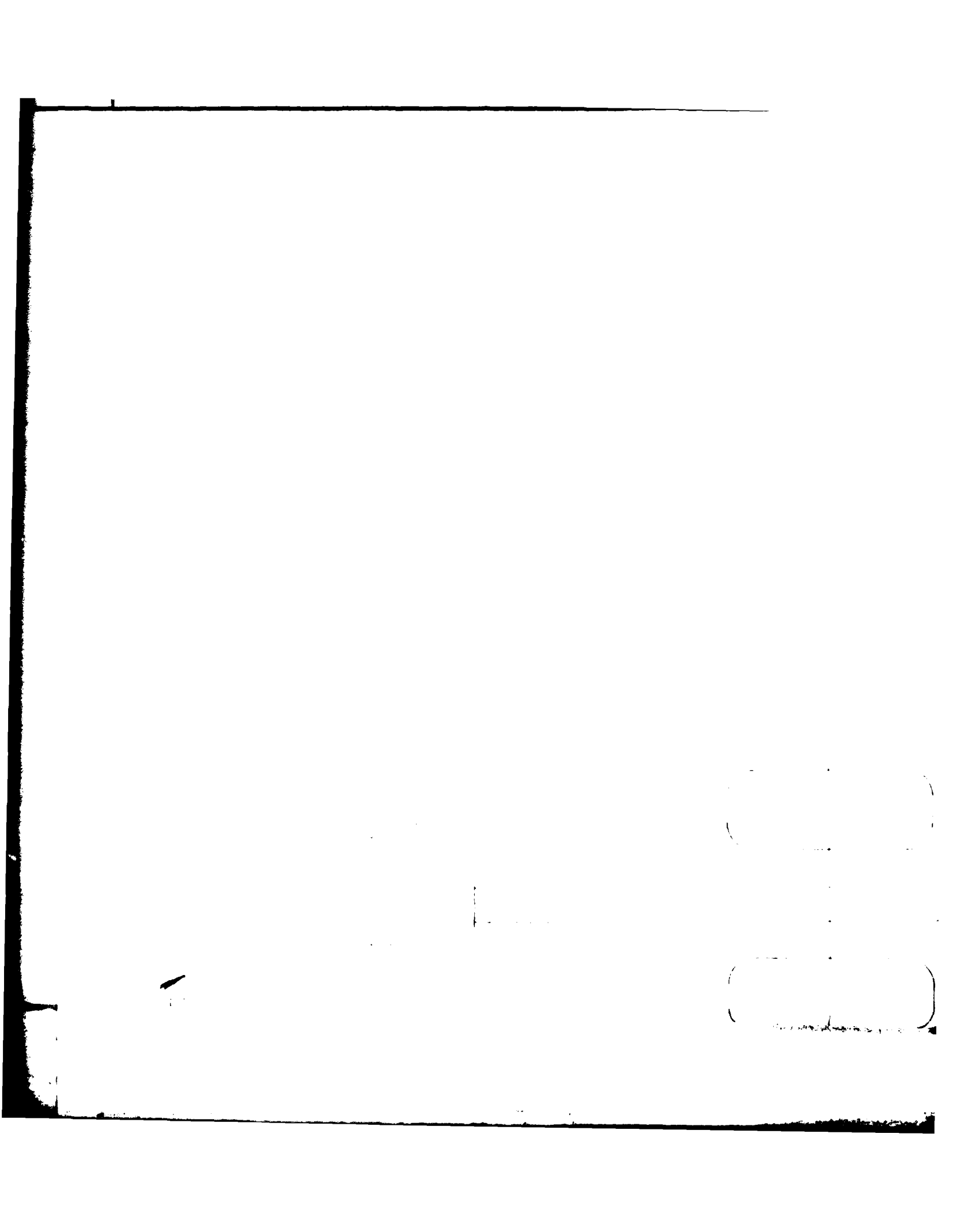

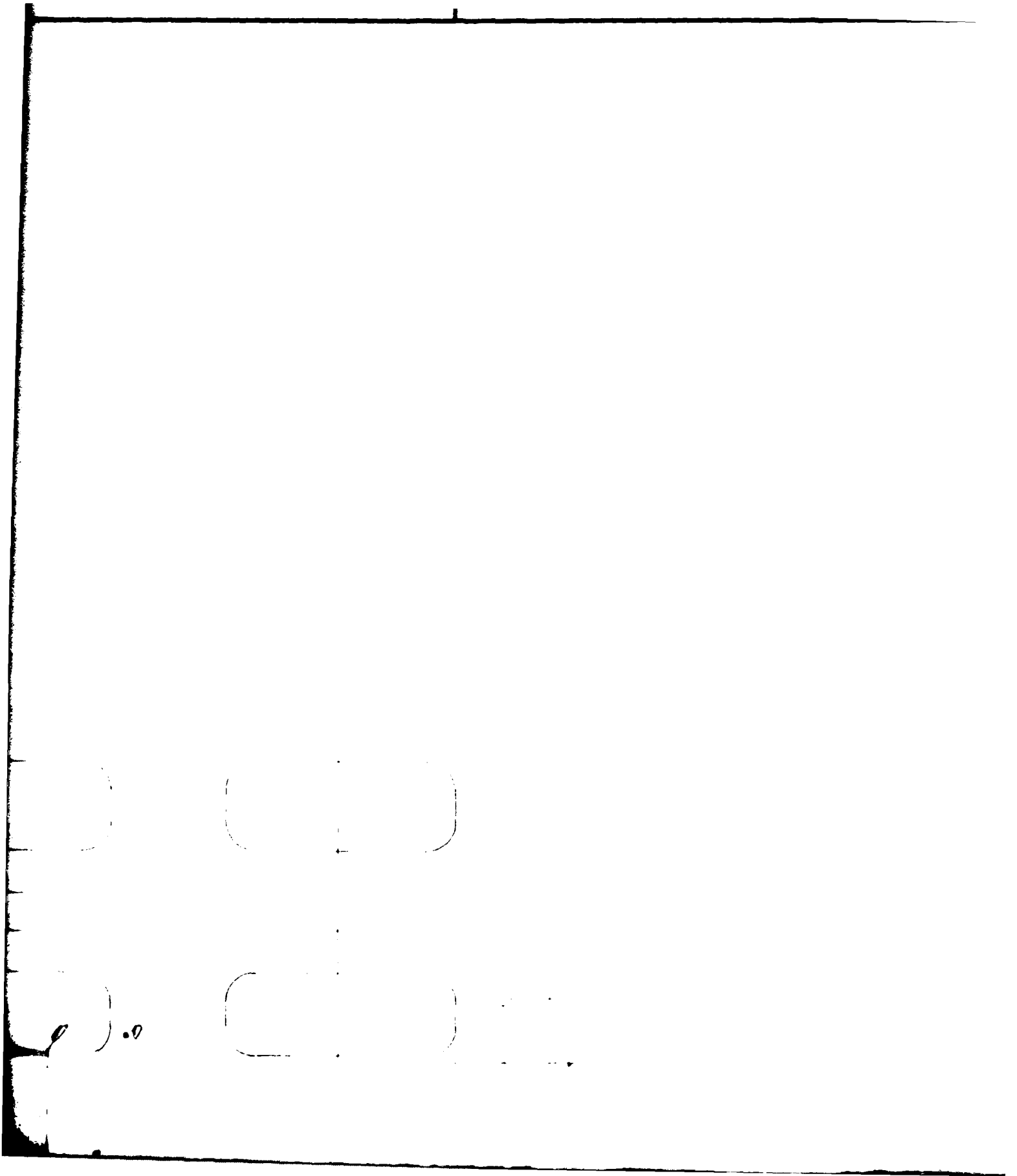

17 FILED

4 OF 5

AD
A/15 131

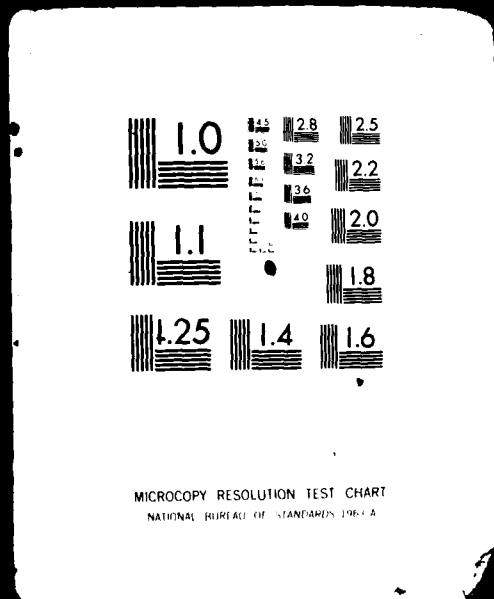

REVISIONS

ZONE LTR

DESCRIPTION

6

2 5

1

6

REVISIONS

ZONE	LTR	DESCRIPTION	DATE	APPROVED

H

G

7

F

E

135 - J. W. N. TRANSPORT

10

0

5

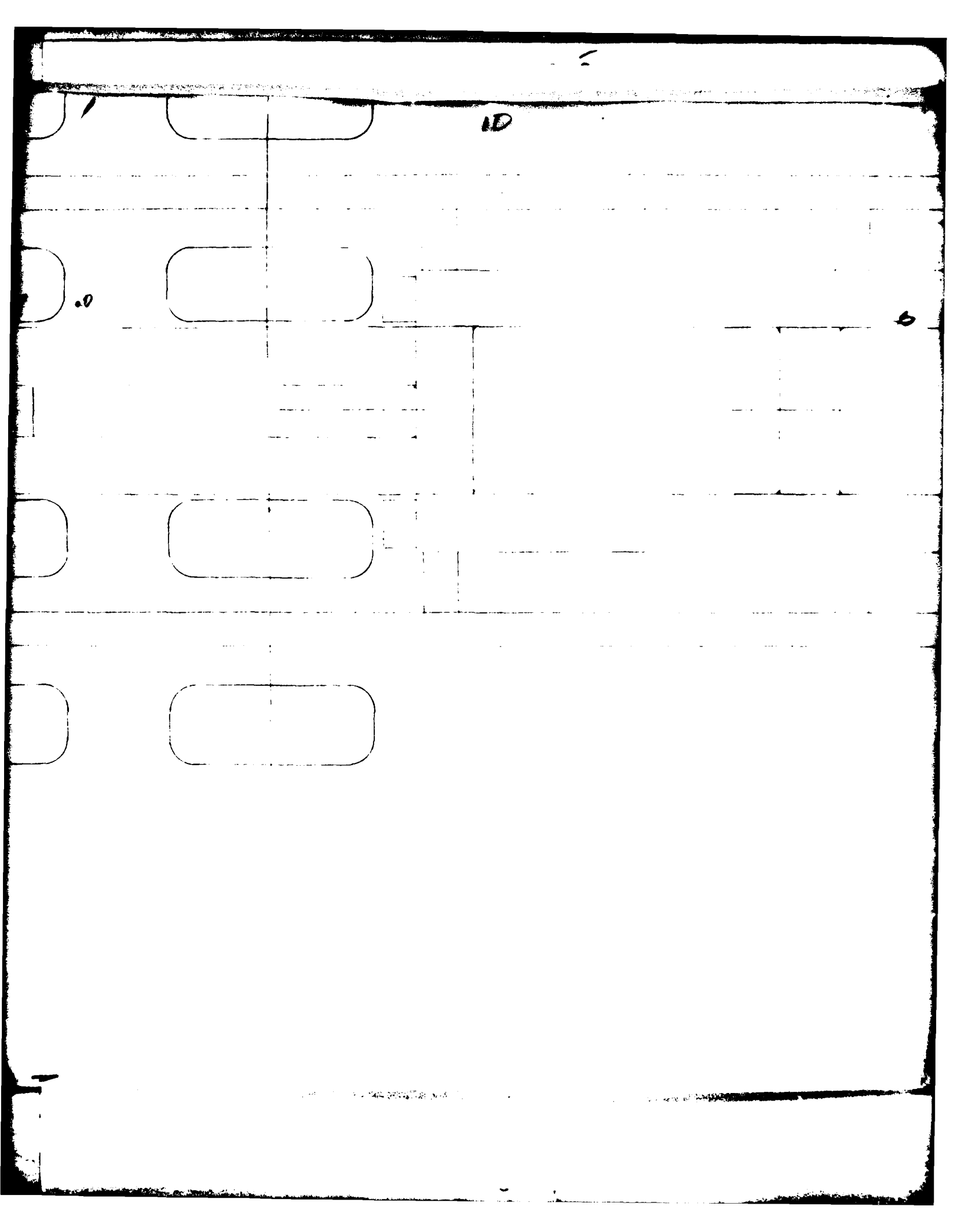

11

6

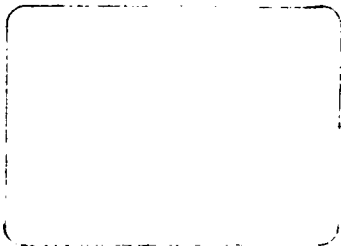

11

1

12



F

E

13

110 111 112 113 114 115 116 117 118 119 120

D

C



14

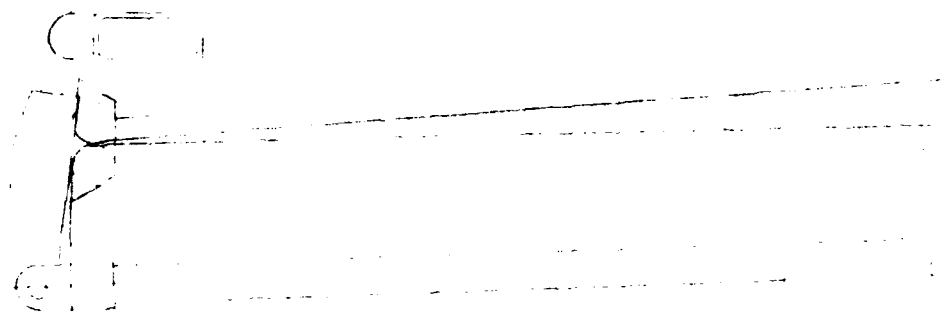

2+

15

406

ENCLOSURE

1947

AIR TRANSPORT - 35

2

3

4

16



1
2
3

DI...
STUM...

44 5/7

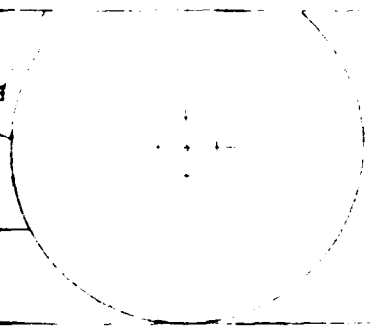

...

4

17

1



4
SHOWING
THAT...

17

18

D

C

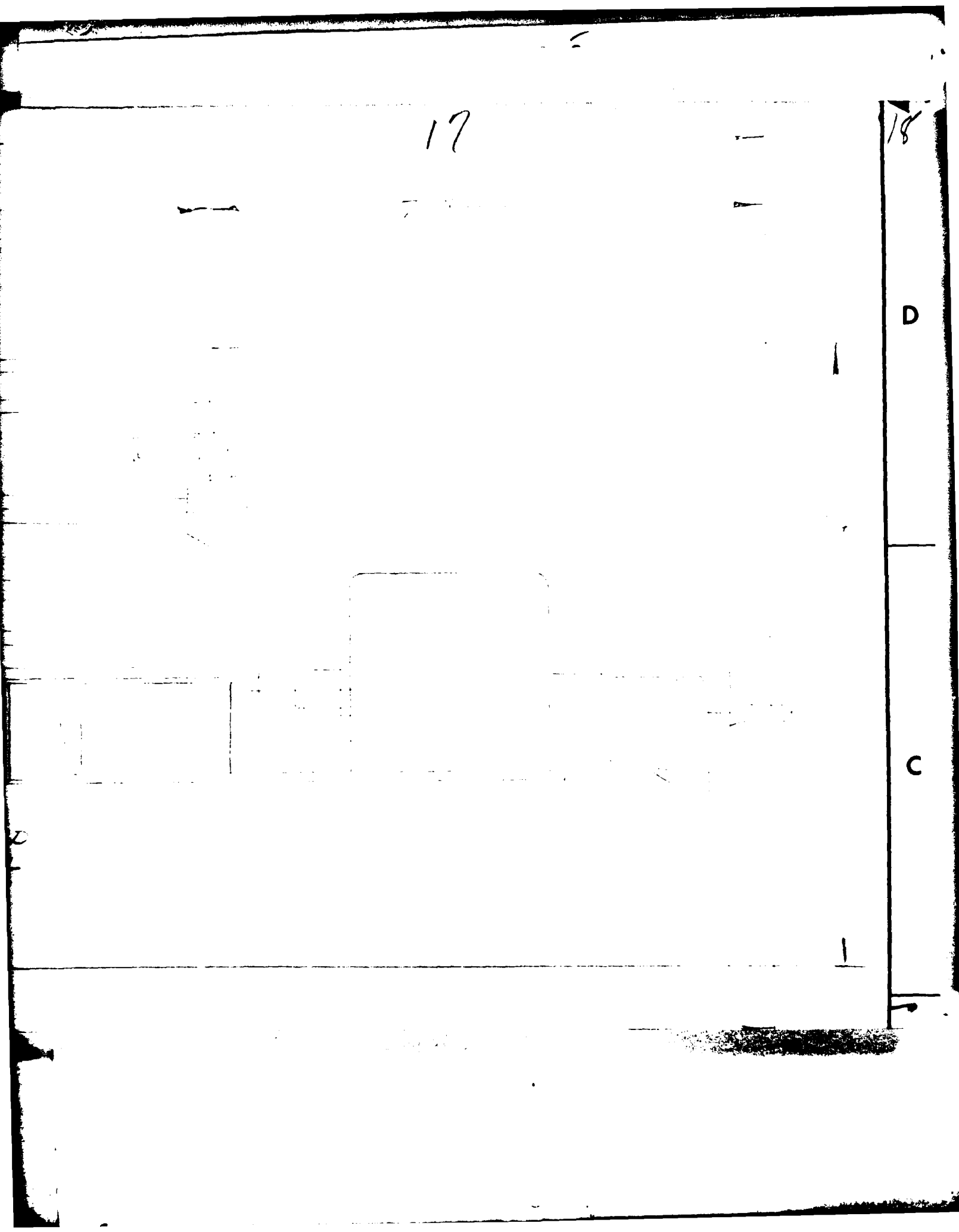

B

A

ADL-221-478-1M

8

19

7

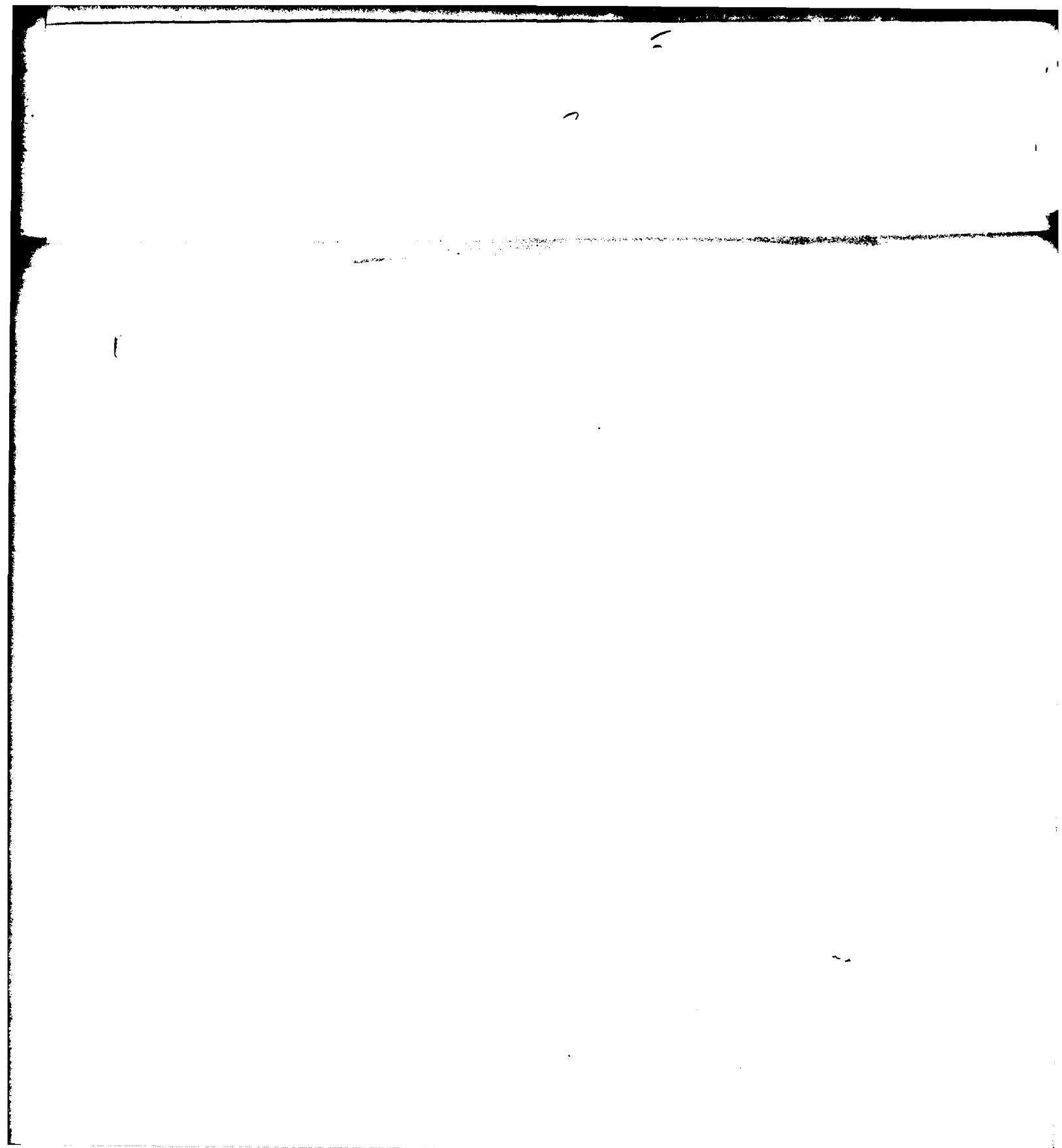

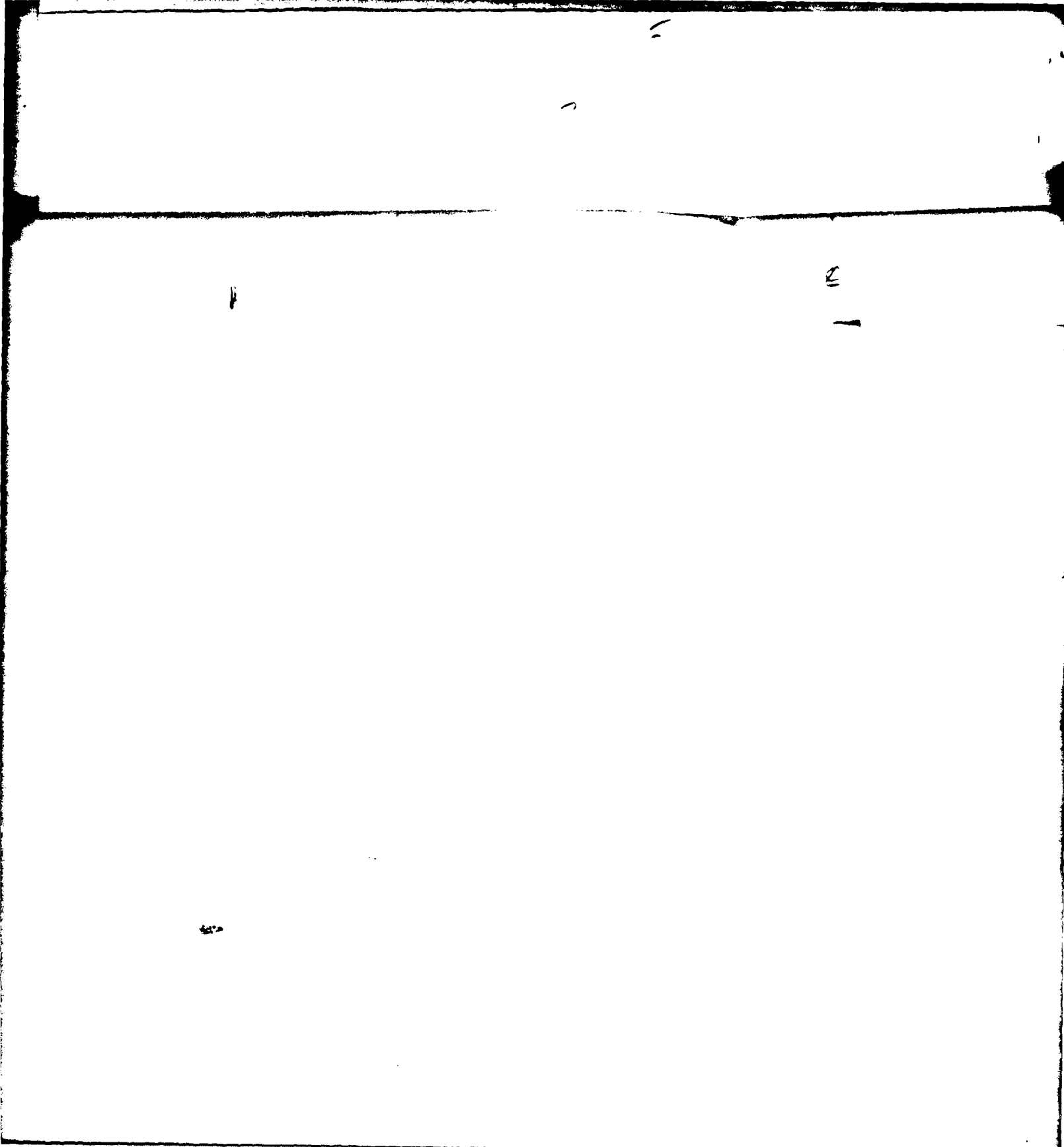

277 210-114

3

NEXT ASSY	USED ON
APPLICATION	

E
REV.

B

PART OR IDENTIFYING NO.

NOMENCLATURE OR DESCRIPTION

MATERIAL

LIST OF PARTS

ISSUE DATE:

DRAWN

CHECKED

APPROVED



Arthur D. Little, Inc.
CAMBRIDGE, MASSACHUSETTS 02140

CLASSIFIED DOCUMENT
PRELIMINARY DESIGN
TERRILL FLIP-LANCHA BRIDGE

A

SIZE

CODE IDENT NO.

DRAWING NO.

REVISION

E

75629

419E

CASE

SCALE

SHEET

2 23

1

24

8

7

This drawing is not to be used for making reproductions thereof, or for making any apparatus based thereon, without first obtaining written authorization of Arthur D. Little, Inc.

H

G

10

11

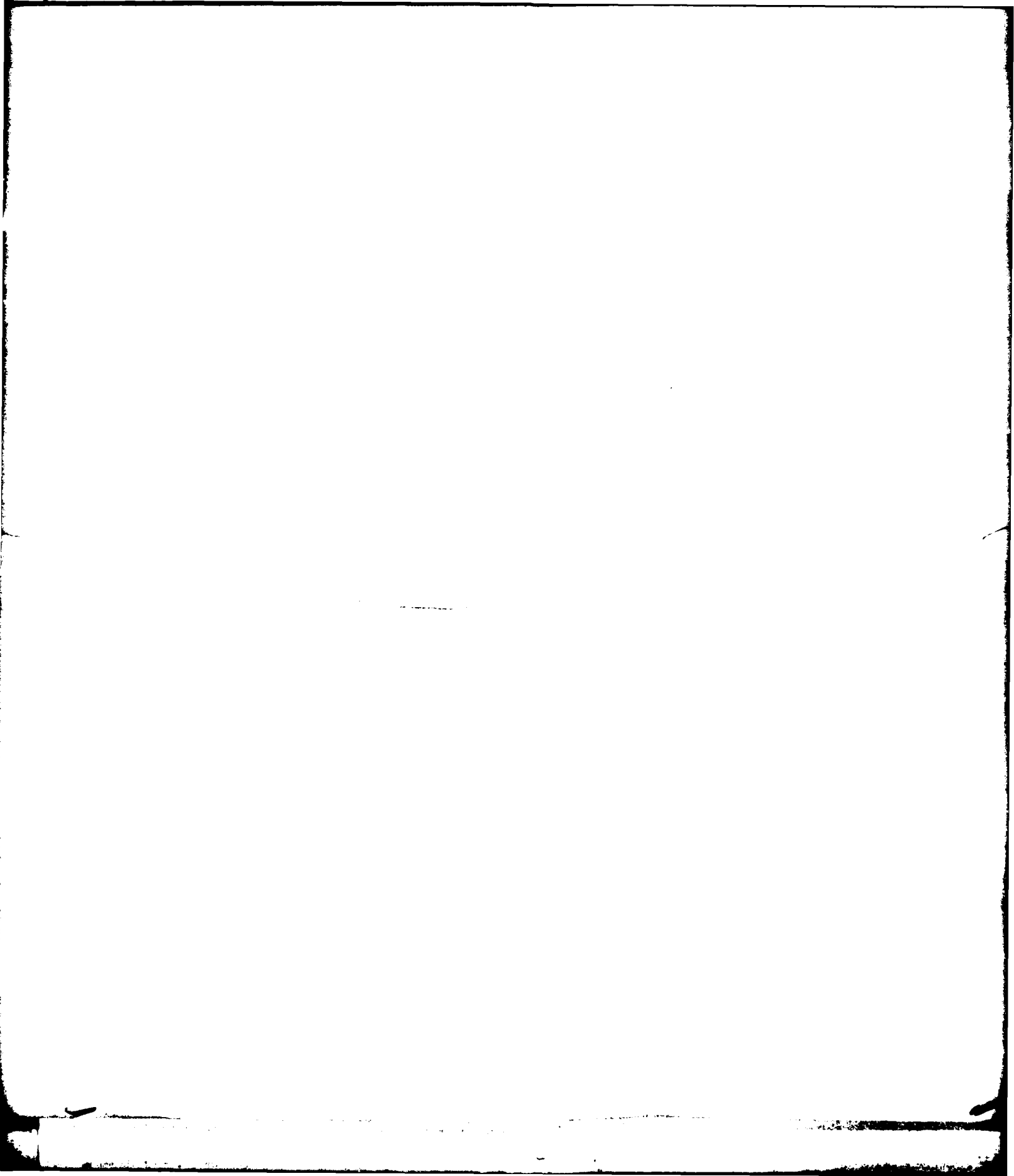

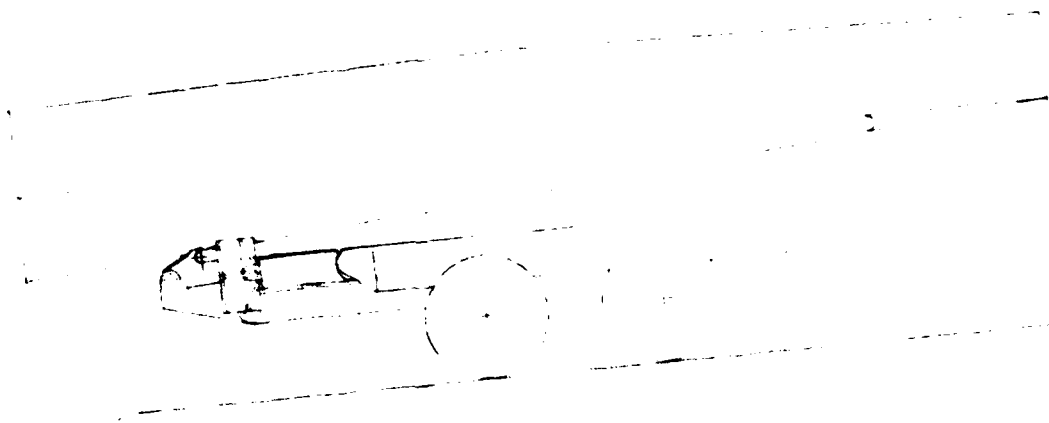

WHEELS ADJUSTED

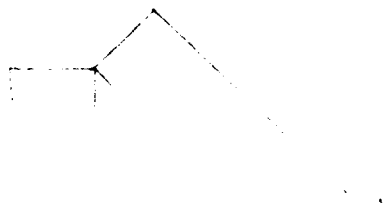

2

5

1

REVISIONS

ZONE LTR

DESCRIPTION

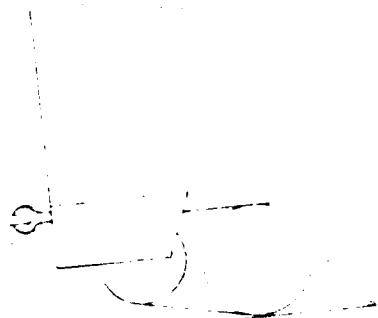

2

5

1

1

6

REVISIONS

ZONE	LTR	DESCRIPTION	DATE	APPROVED

H

C

7

12

F

E



A

46

1

2

3

4

5

9

10



1

2

3

4

11



C
E

11

12

F

E

D



17

c

B

14

1

10

17

ITEM NO.	QTY REQ	PART OR IDENTIFYING NO.	NOMENCLATURE OR DESCRIPTION	MATERIAL
----------	---------	-------------------------	-----------------------------	----------

LIST OF PARTS

UNLESS OTHERWISE

ISSUE DATE:

17

18

C

E
REV.

B

PART OR IDENTIFYING NO.

NOMENCLATURE OR DESCRIPTION

MATERIAL

LIST OF PARTS

ISSUE DATE:

Arthur D Little Inc.

B

A

ADL-221-478-1M

8

19

7

7

1

20

6

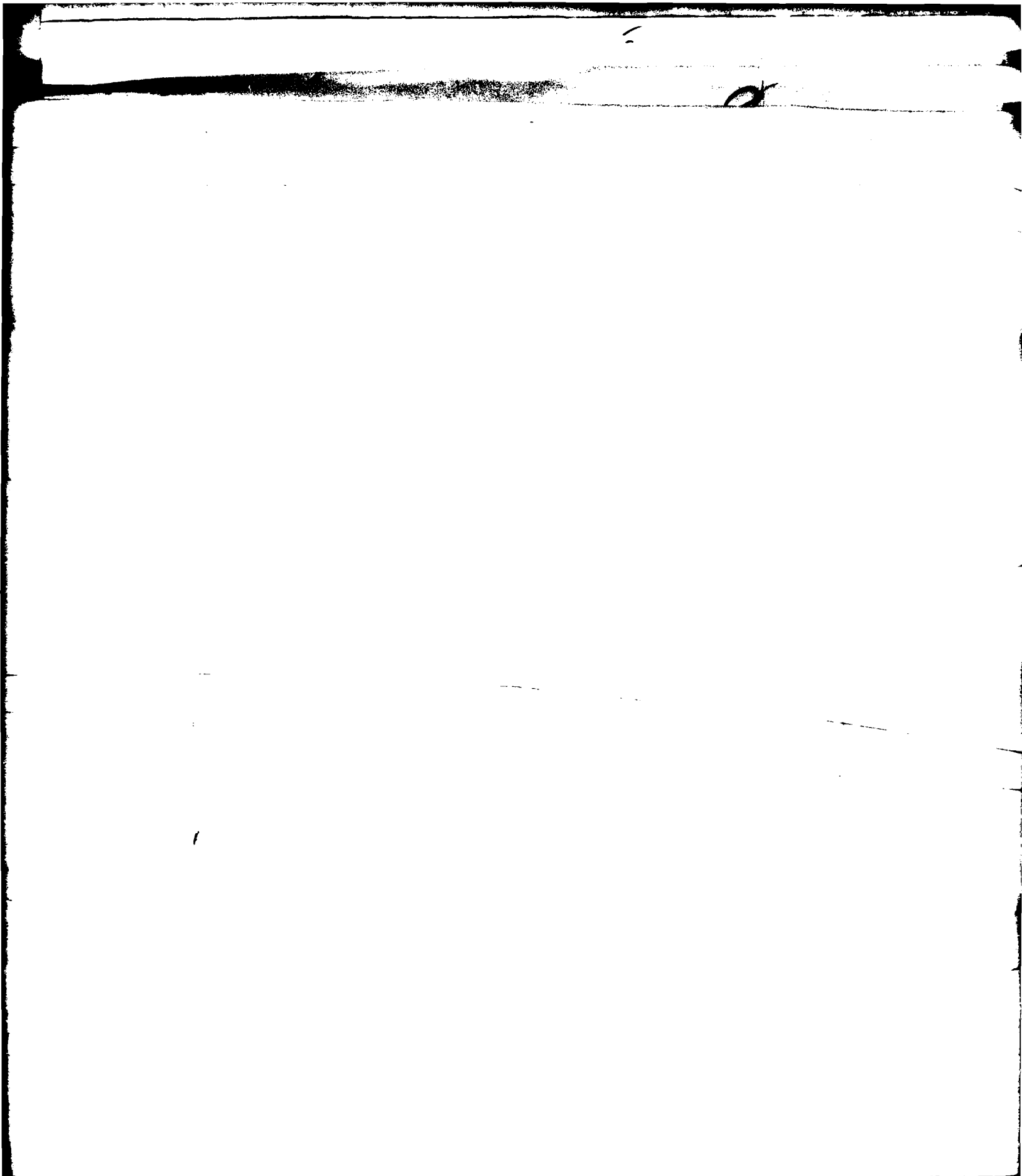

17

22



4

3

NEXT ASSY	U
APPLICATION	

ITEM NO.	QTY REQ	PART OR IDENTIFYING NO.	NOMENCLATURE OR DESCRIPTION
----------	---------	-------------------------	-----------------------------

LIST OF PARTS

UNLESS OTHERWISE SPECIFIED		ISSUE DATE:					
DIMENSIONS ARE IN INCHES TOLERANCES:		DRAWN					
DECIMAL .XX = ± .010 .XXX = ± .005	FRACTIONAL ± 1/64	CHECKED					
	ANGULAR ± 1°	APPROVED					
FINISHED SURFACES RMS BREAK SHARP CORNERS							
DO NOT SCALE THIS DRAWING						SIZE	CODE IDENT NO.
MATERIAL						E	75629
		APPLICATION		CASE		SCALE	

BSY USED ON
 APPLICATION

E
REV.

B

A

PART OR IDENTIFYING NO.	NOMENCLATURE OR DESCRIPTION	MATERIAL
-------------------------	-----------------------------	----------

LIST OF PARTS

ISSUE DATE:	 Arthur D. Little, Inc. CAMBRIDGE, MASSACHUSETTS 02140		
DRAWN			
CHECKED			
APPROVED			
CASE	SIZE	CODE IDENT NO.	DRAWING NO.
3-11-53	E	75629	4125-012
	SCALE		REVISION
			SHEET 1

2-11-53
 3-11-53
 4-11-53
 5-11-53
 6-11-53
 7-11-53
 8-11-53
 9-11-53
 10-11-53
 11-11-53
 12-11-53

2 2 3

1

27

This drawing is not to be used for making reproductions thereof, or for making any apparatus based thereon, without first obtaining written authorization of Arthur D. Little, Inc.

H

G



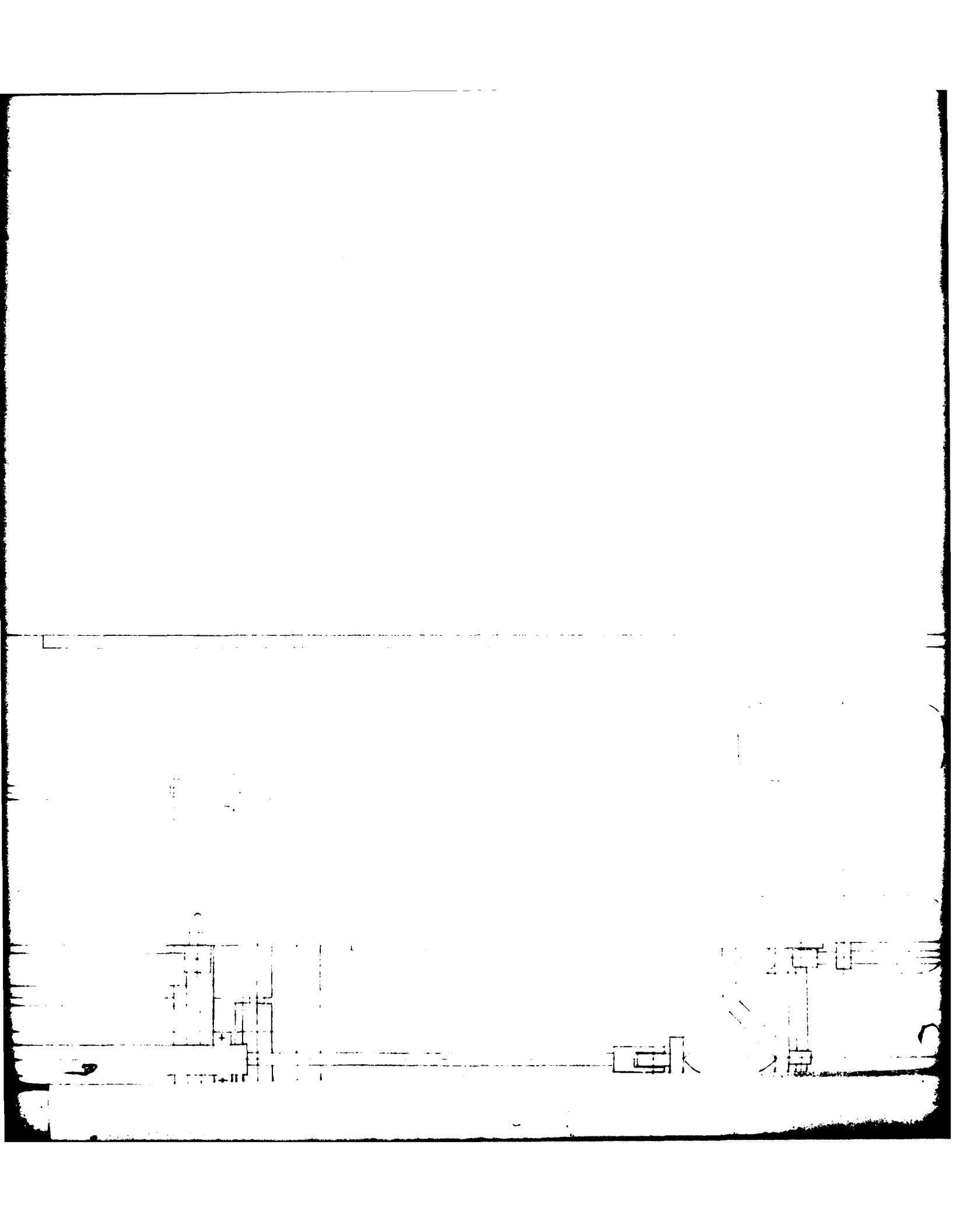

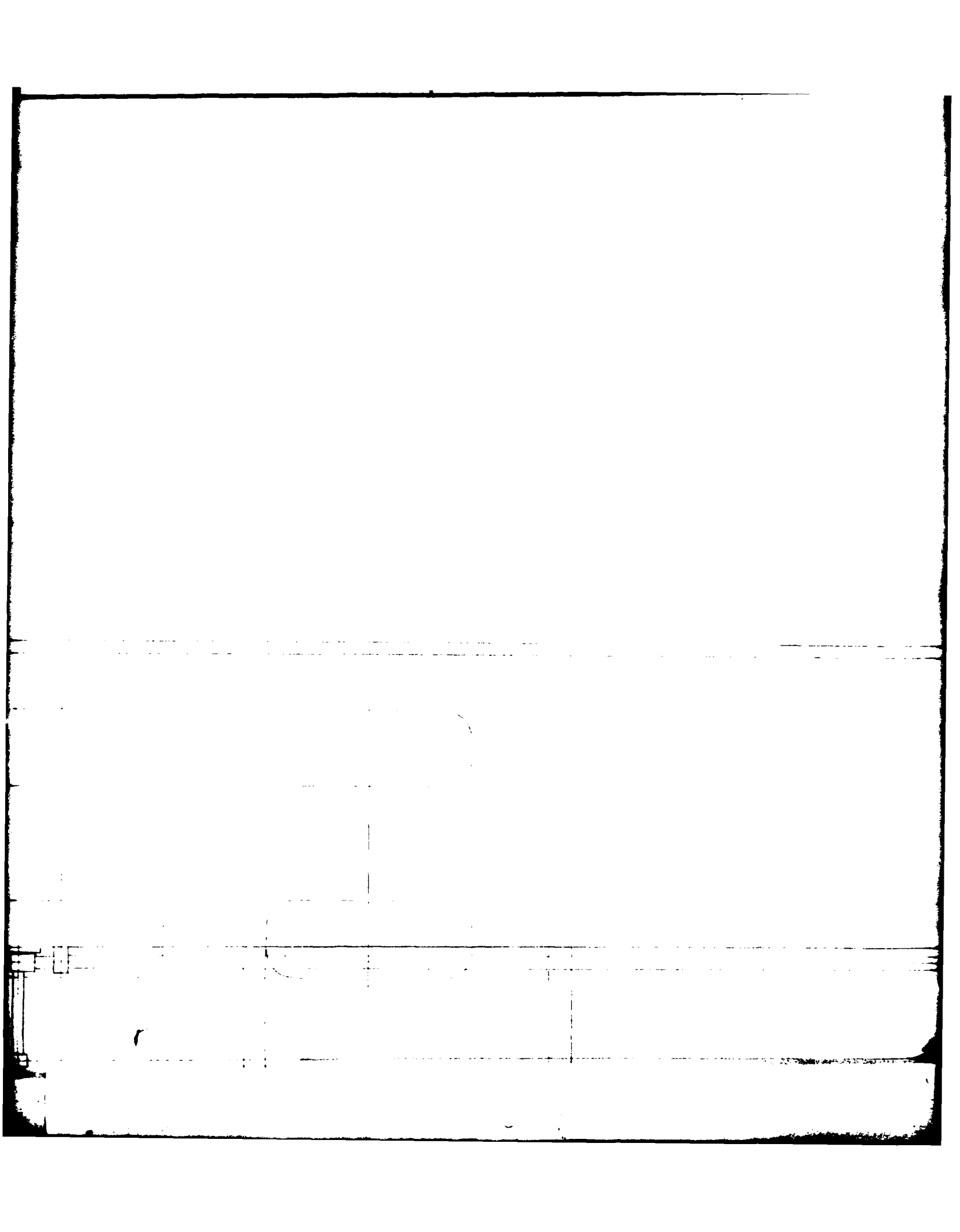

REVISIONS

ZONE LTR

DESCRIPTION

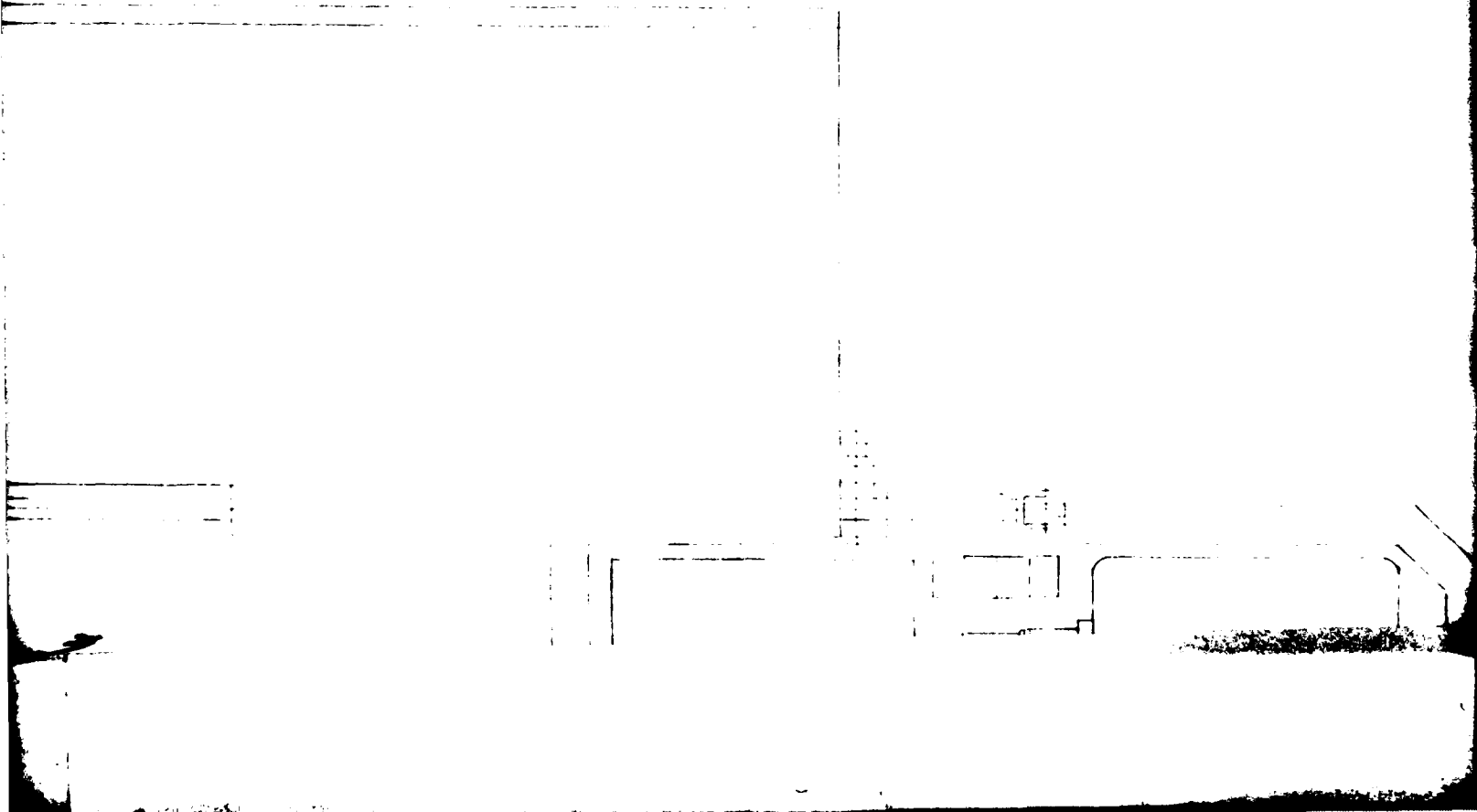

2

5

1

6

REVISIONS

ZONE	LTR	DESCRIPTION	DATE	APPROVED

H

G

E

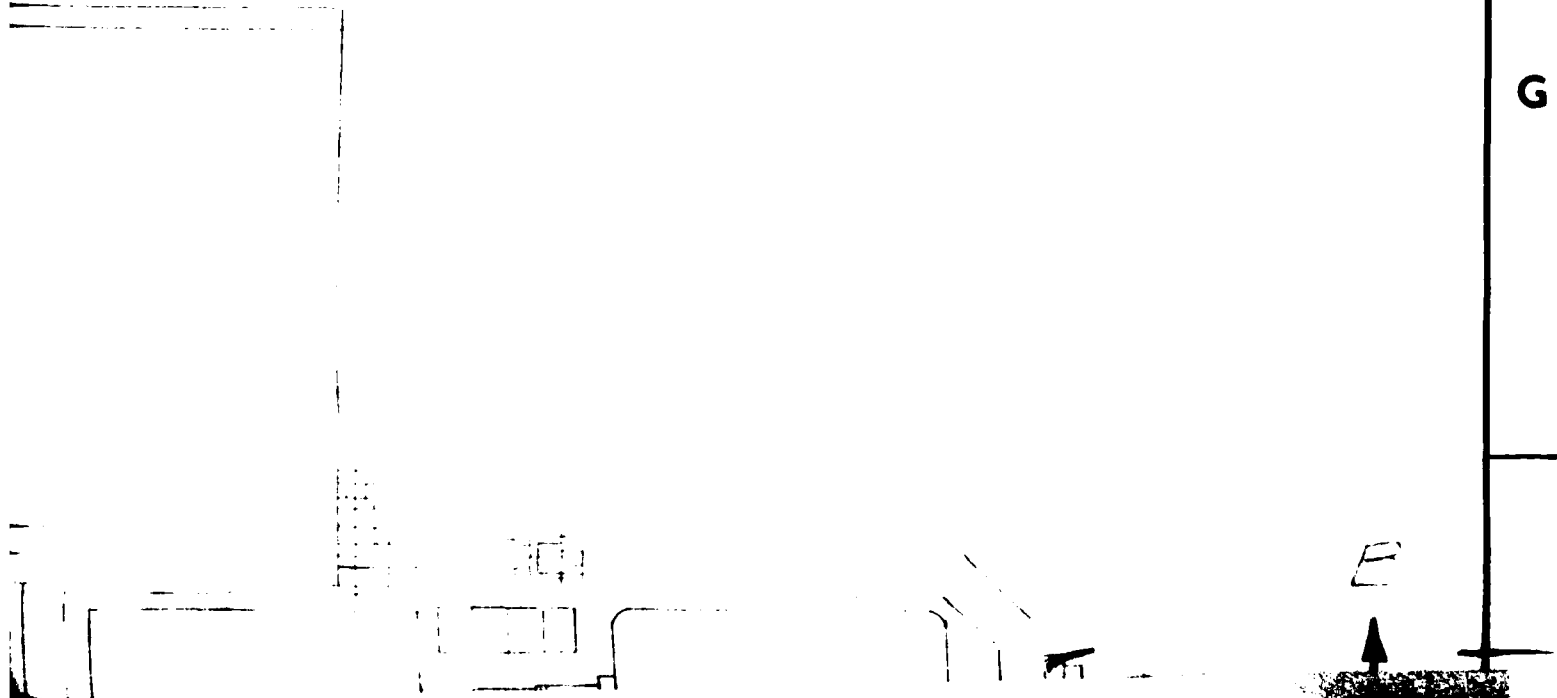

F

E

110° STONE ?

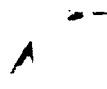
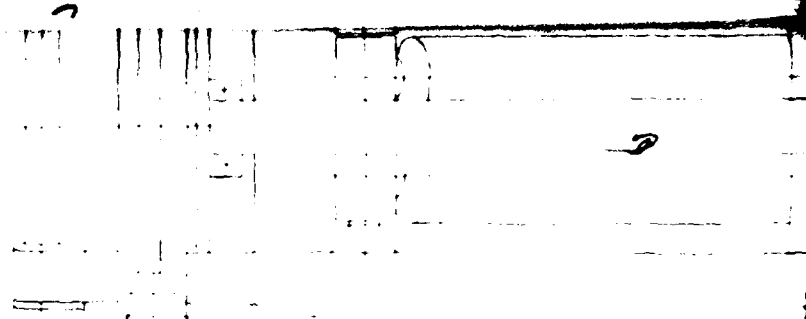

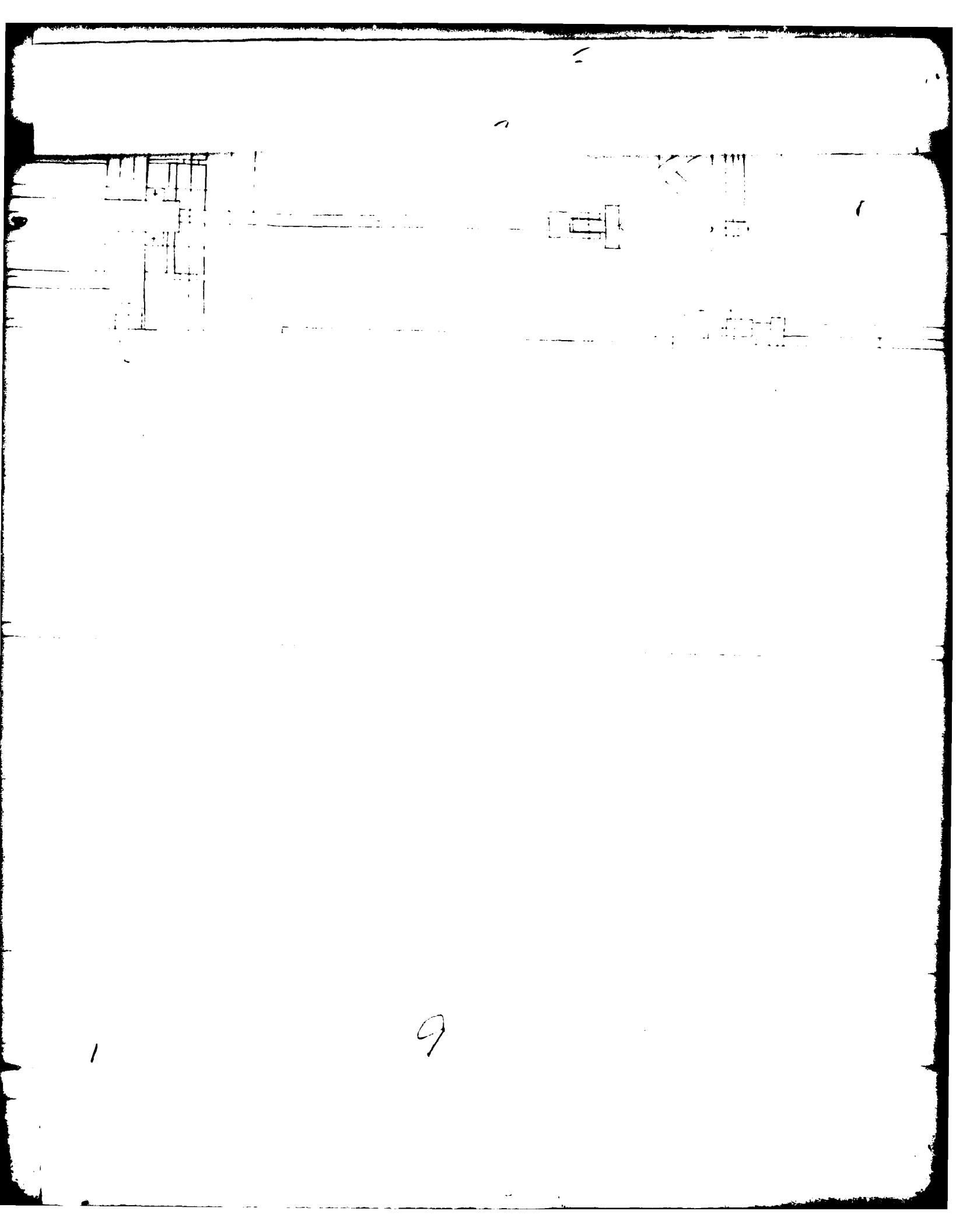

10

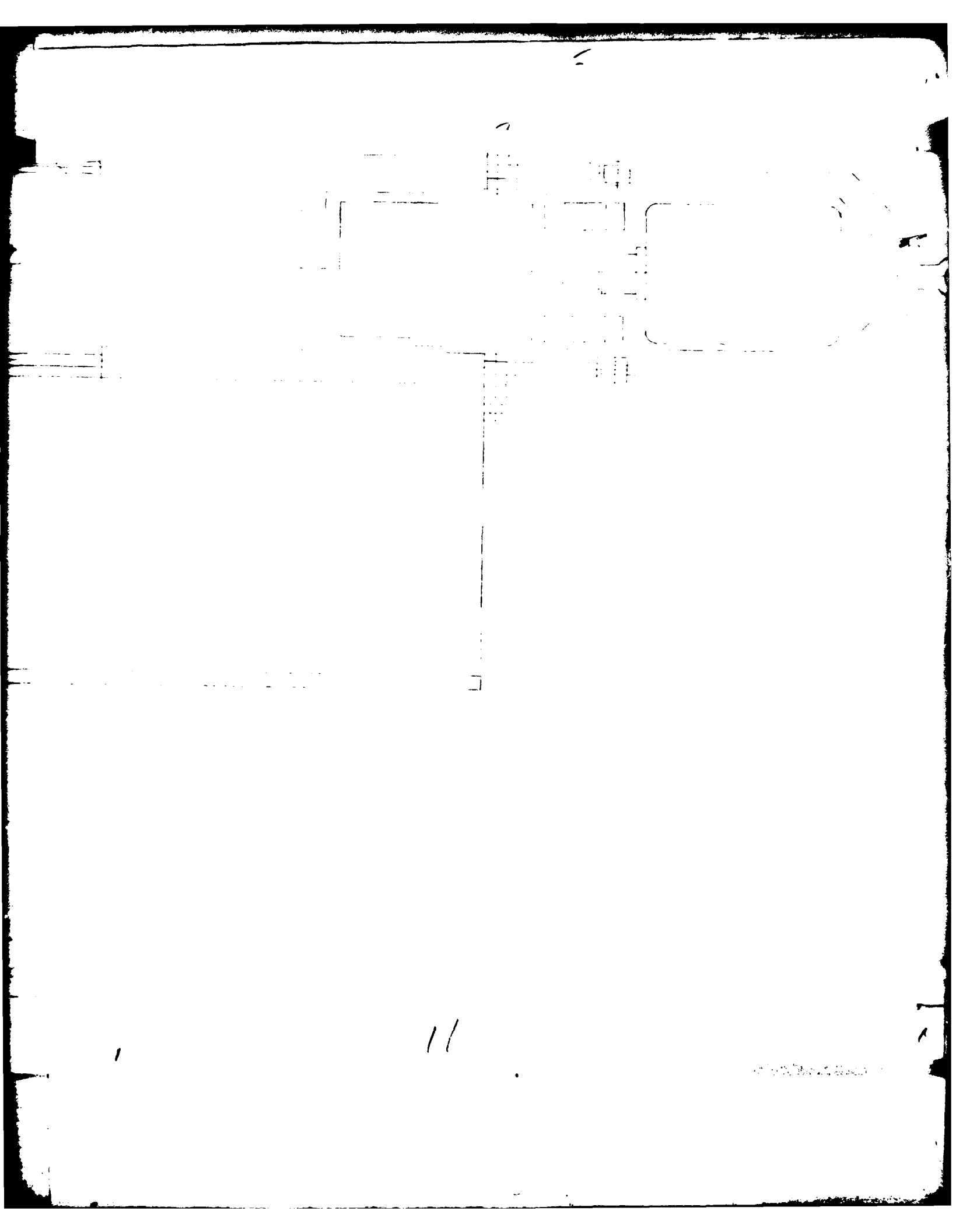

11

1950

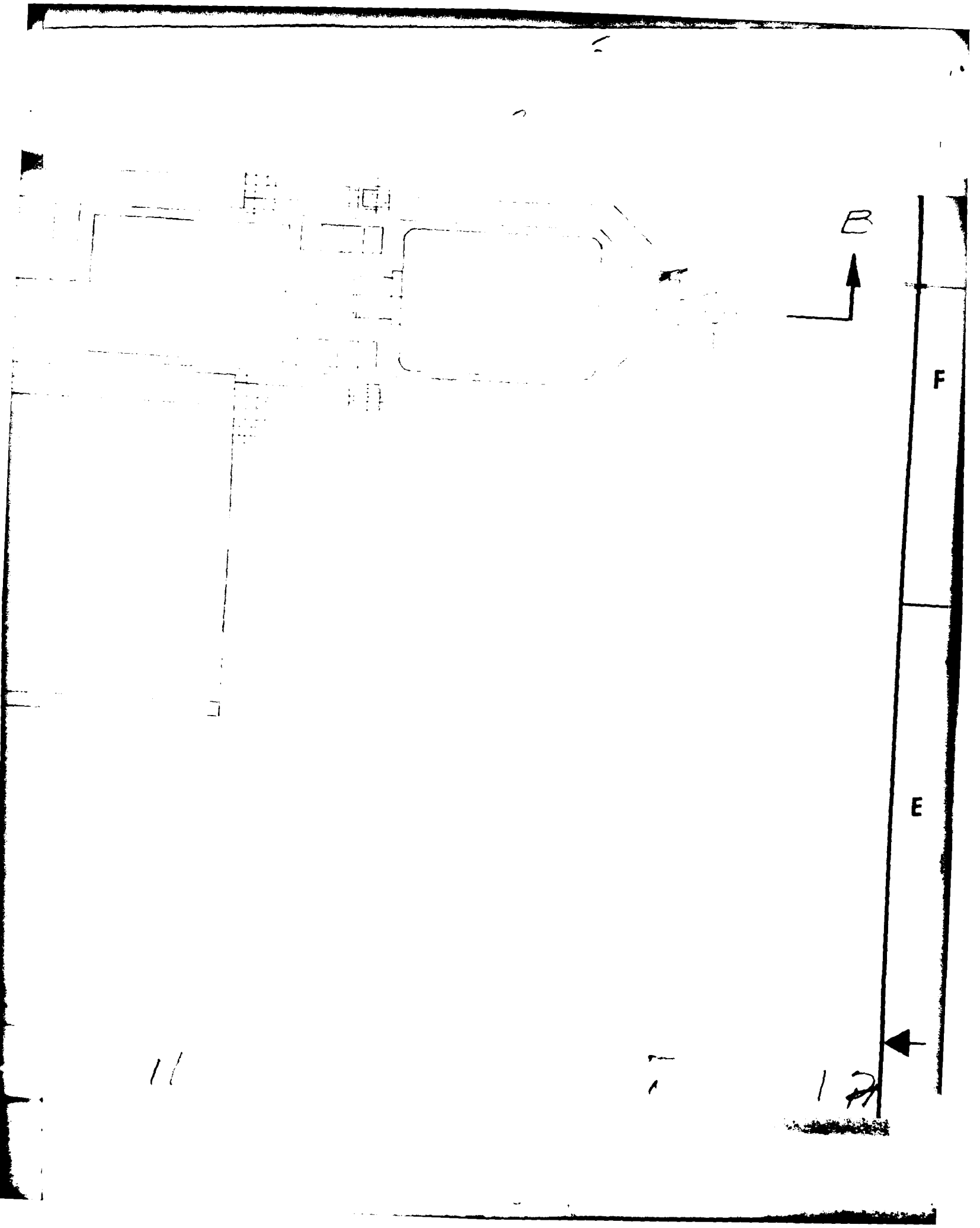

B

F

E

12

11

2

13 30

D

C

B



M

1
2
3
4
5
6
7
8
9
10
11
12

1

2



3



K-E

D

10/15/71

15

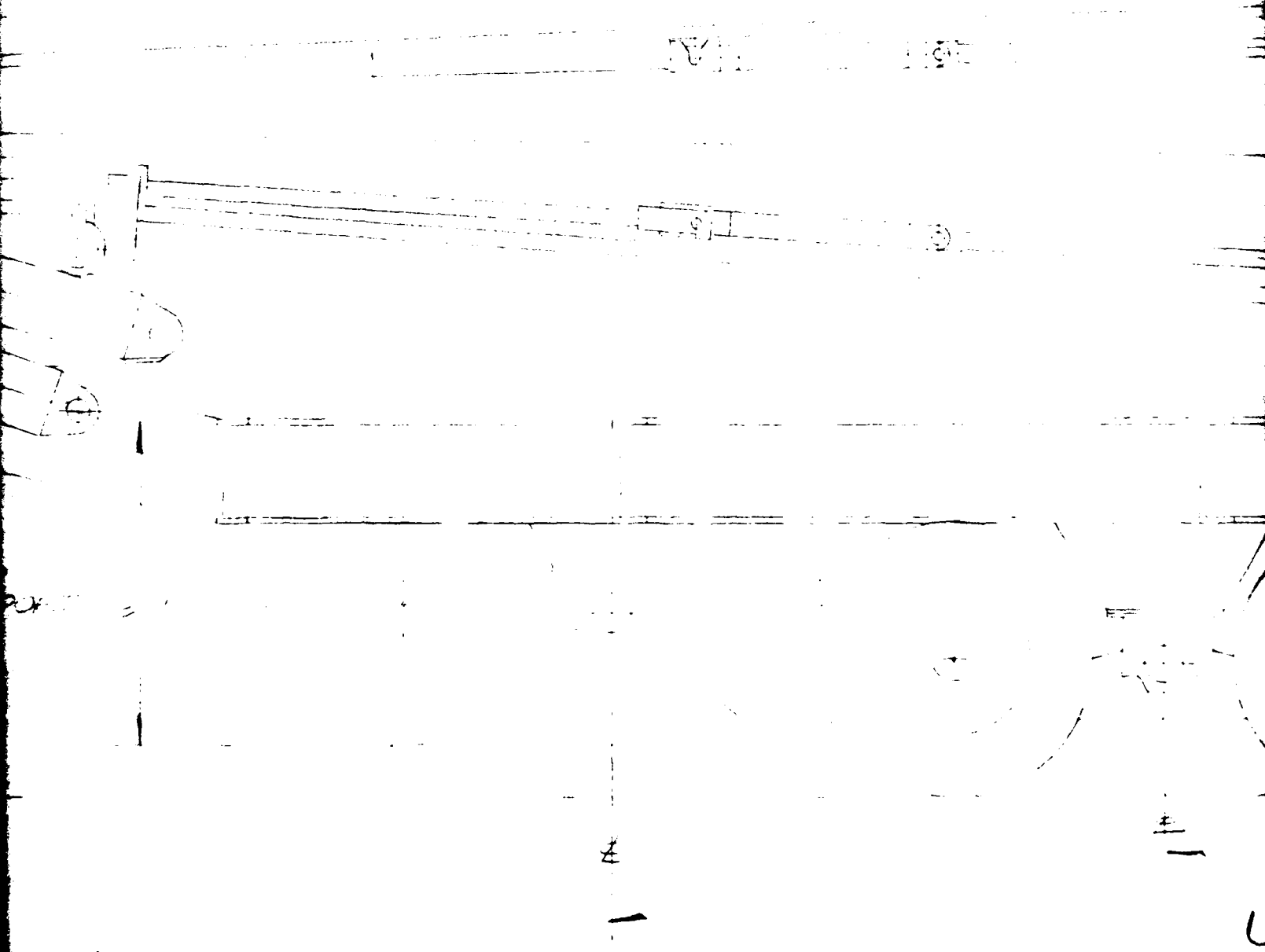

1

16

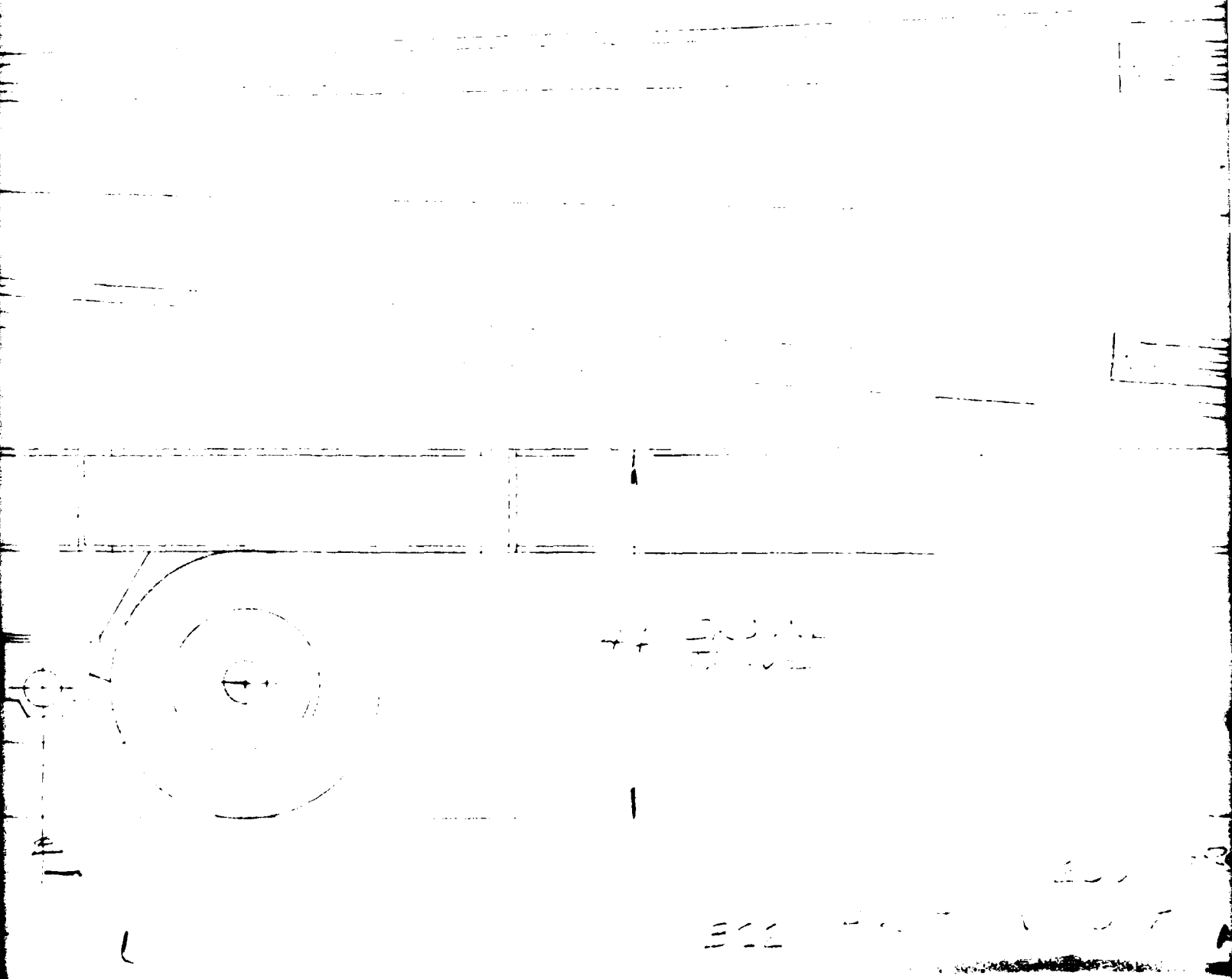

1

+

17

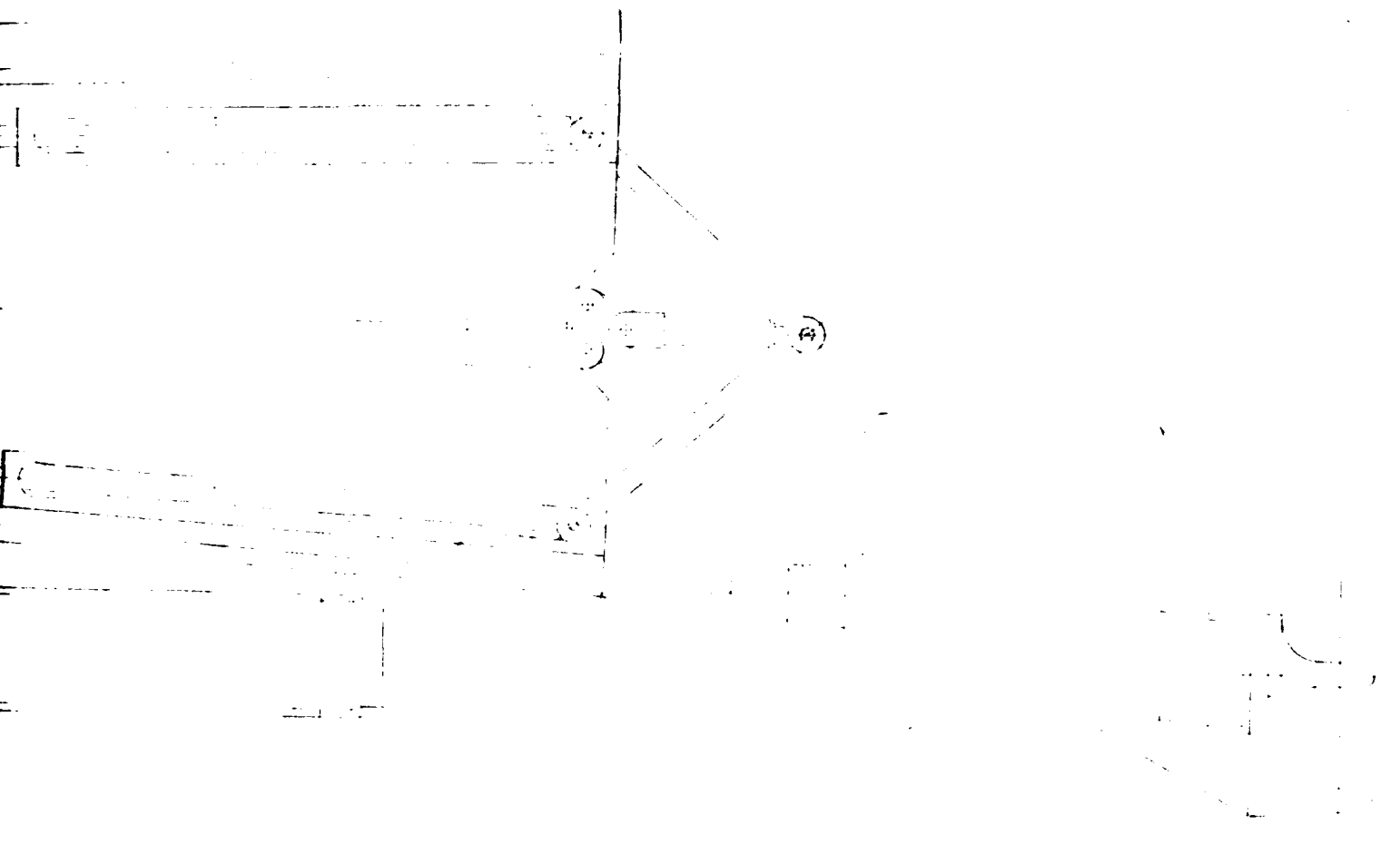

17

1

+

17

-

1

A

D

C

E
+178

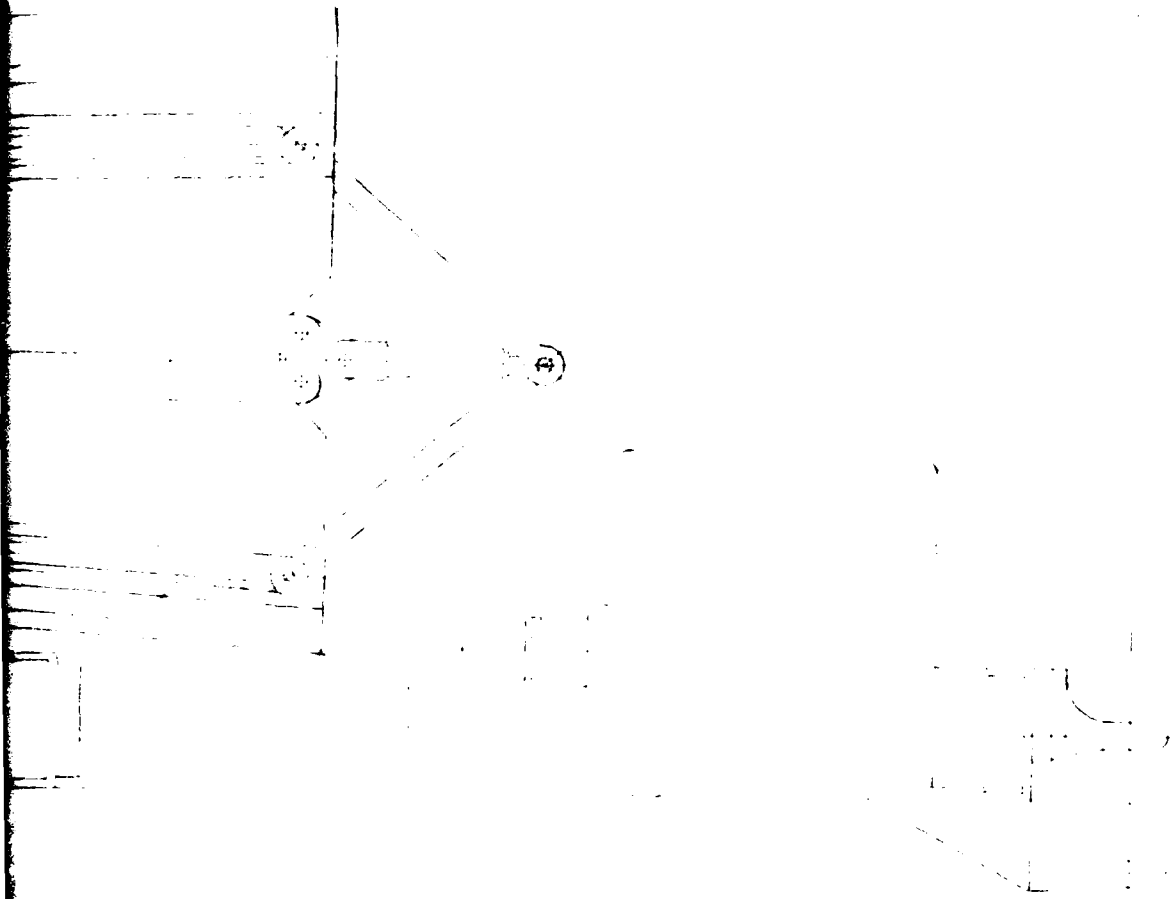

11

2

B

A

ADL-221-478-1M

8

19 |

7

k

100 STOWED

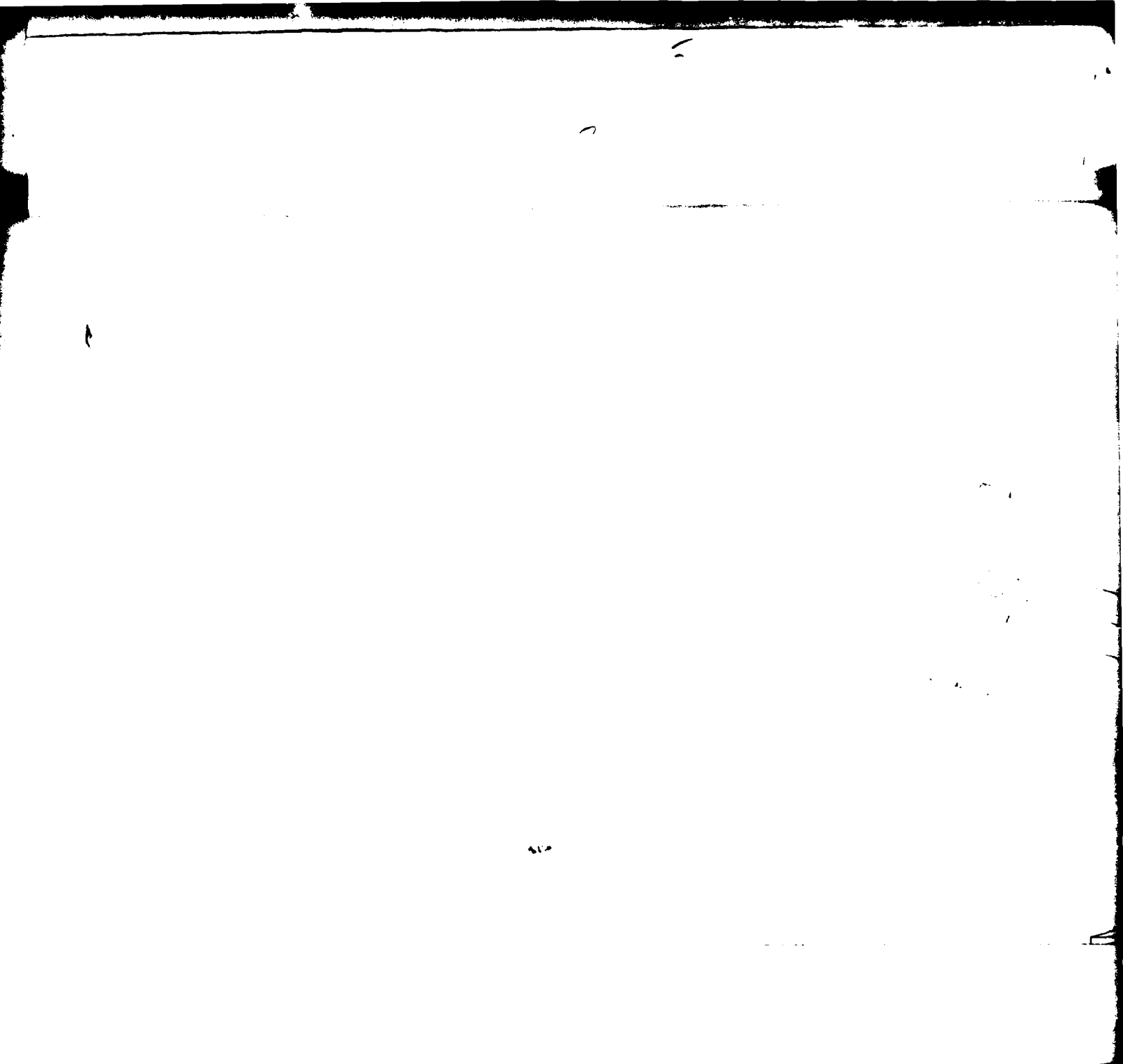

620

0

1

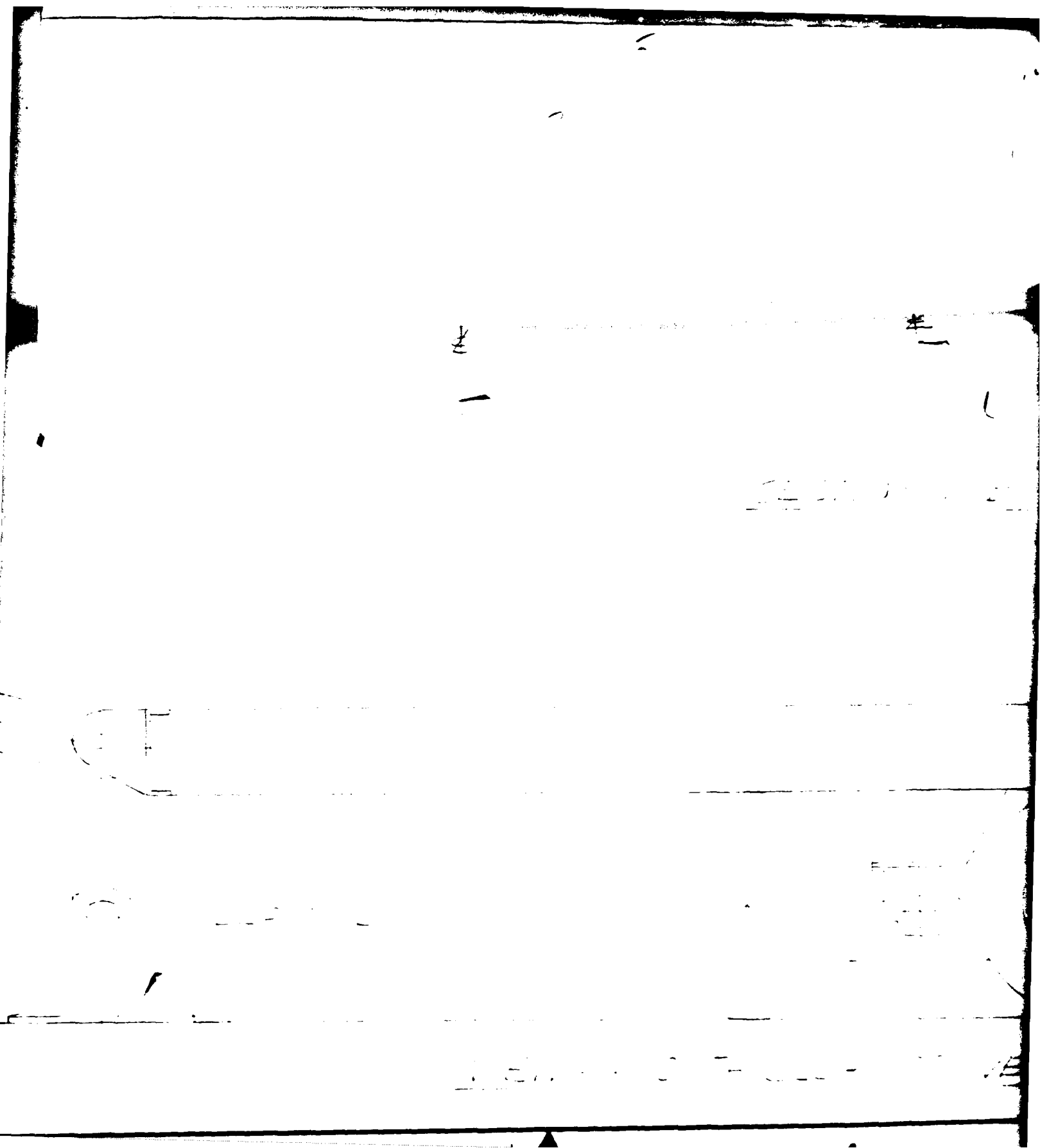

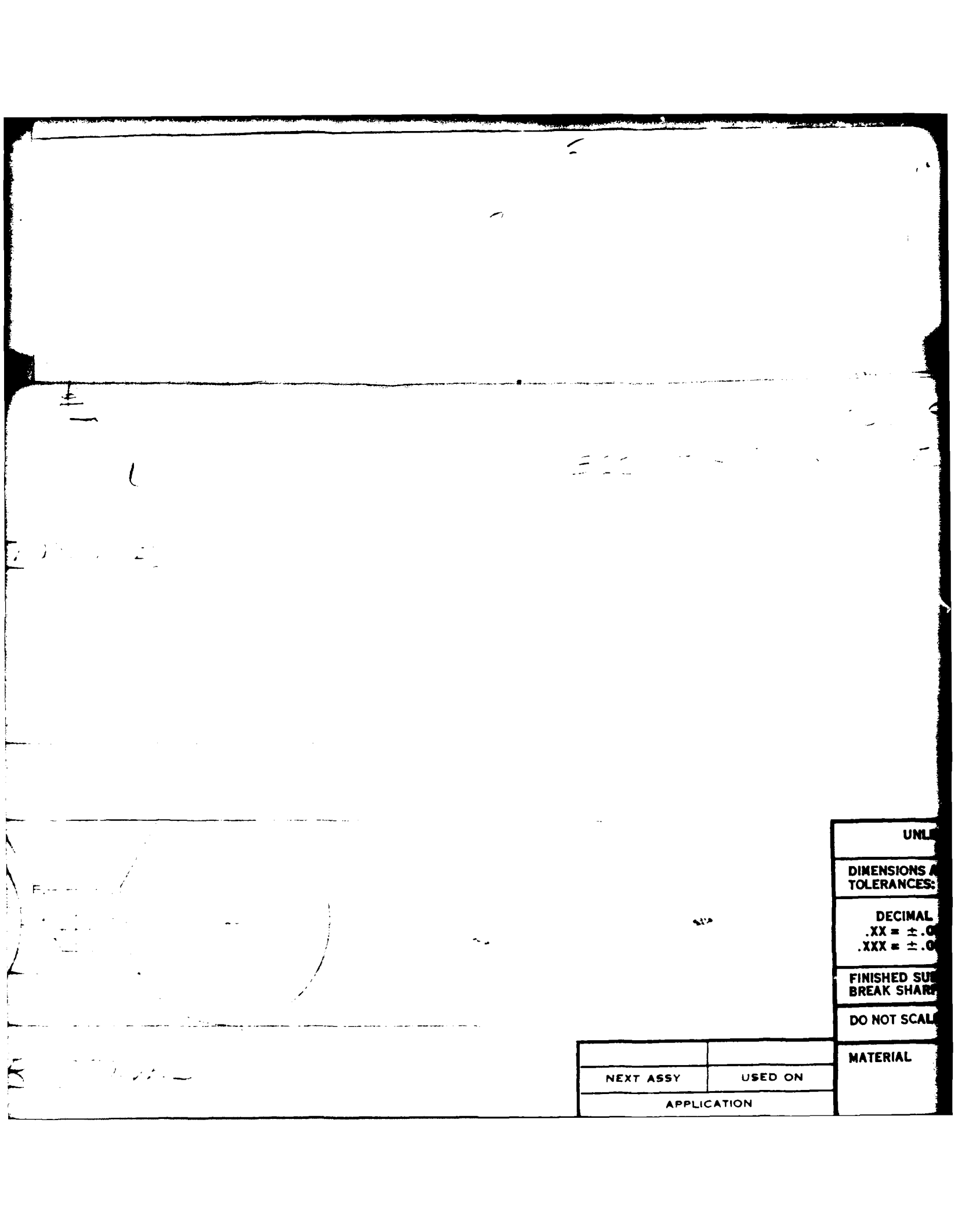

UNLESS
DIMENSIONS AND TOLERANCES:
DECIMAL .XX = ±.0 .XXX = ±.0
FINISHED SURFACE BREAK SHARP
DO NOT SCALE
MATERIAL

NEXT ASSY	USED ON
APPLICATION	

ITEM NO.	QTY REQ	PART OR IDENTIFYING NO.	NOMENCLATURE OR DESCRIPTION	M
----------	---------	-------------------------	-----------------------------	---

LIST OF PARTS

UNLESS OTHERWISE SPECIFIED		ISSUE DATE:		 Arthur D. Little CAMBRIDGE, MA			
DIMENSIONS ARE IN INCHES TOLERANCES:		DRAWN				<i>Handwritten notes and signatures</i>	
DECIMAL .XX = ± .010 .XXX = ± .005	FRACTIONAL ± 1/64 ANGULAR ± 1°	CHECKED		SIZE			
FINISHED SURFACES BREAK SHARP CORNERS RMS		APPROVED		CODE IDENT NO.			
DO NOT SCALE THIS DRAWING		CASE		DRAWING			
MATERIAL				SCALE			

1

2 23

1

REV.

B

A

PART OR IDENTIFYING NO.

NOMENCLATURE OR DESCRIPTION

MATERIAL

LIST OF PARTS

ISSUE DATE:	
DRAWN	
CHECKED	
APPROVED	
CASE	



Arthur D. Little, Inc.
CAMBRIDGE, MASSACHUSETTS 02140

SIZE	CODE IDENT NO.	DRAWING NO.	REVISION
E	75629	4-1-71	
SCALE	SHEET		251

2 23

11

24

8

7

This drawing is not to be used for making reproductions thereof, or for making any apparatus based thereon, without first obtaining written authorization of Arthur D. Little, Inc.

H

G

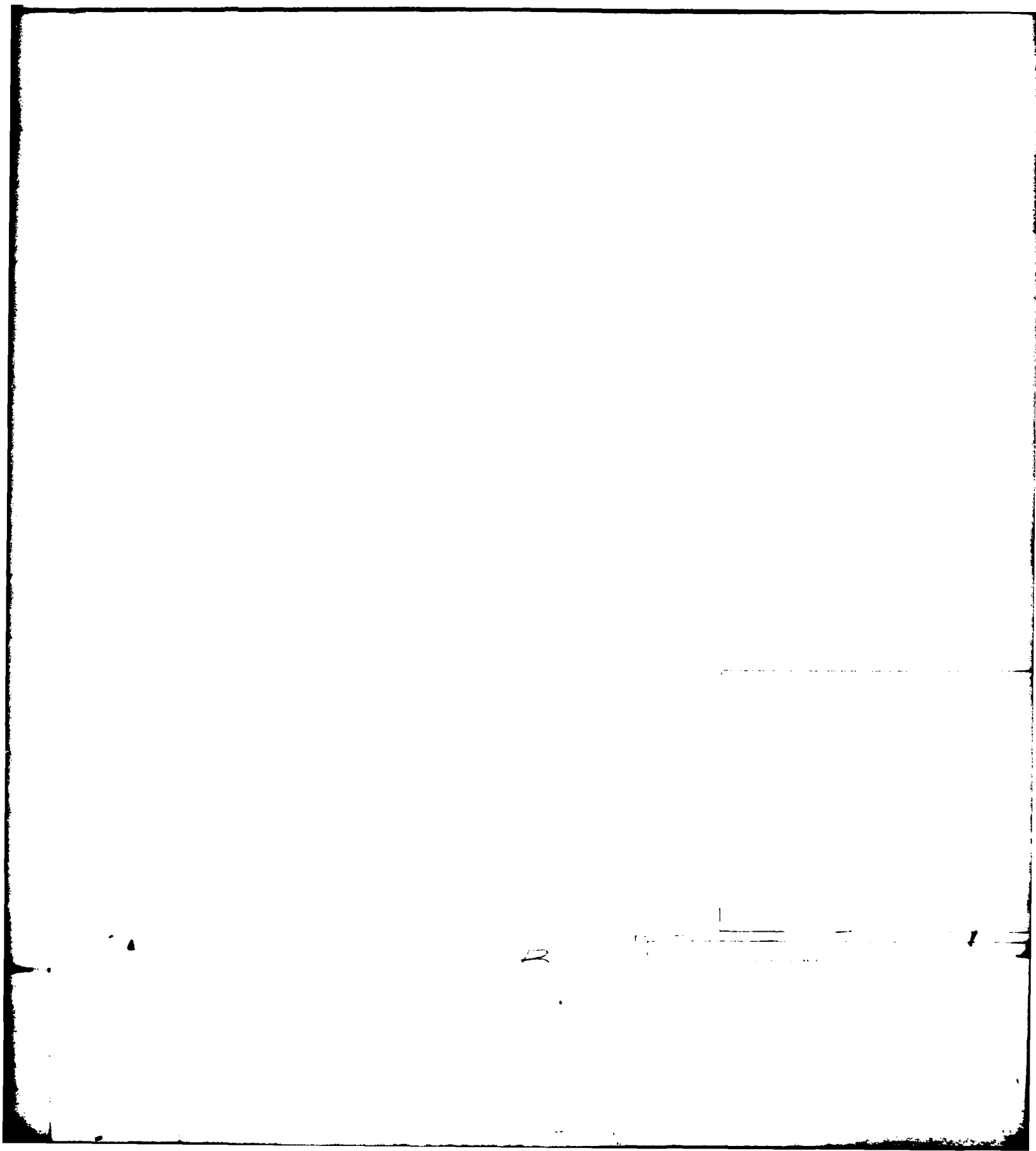

1 |

53



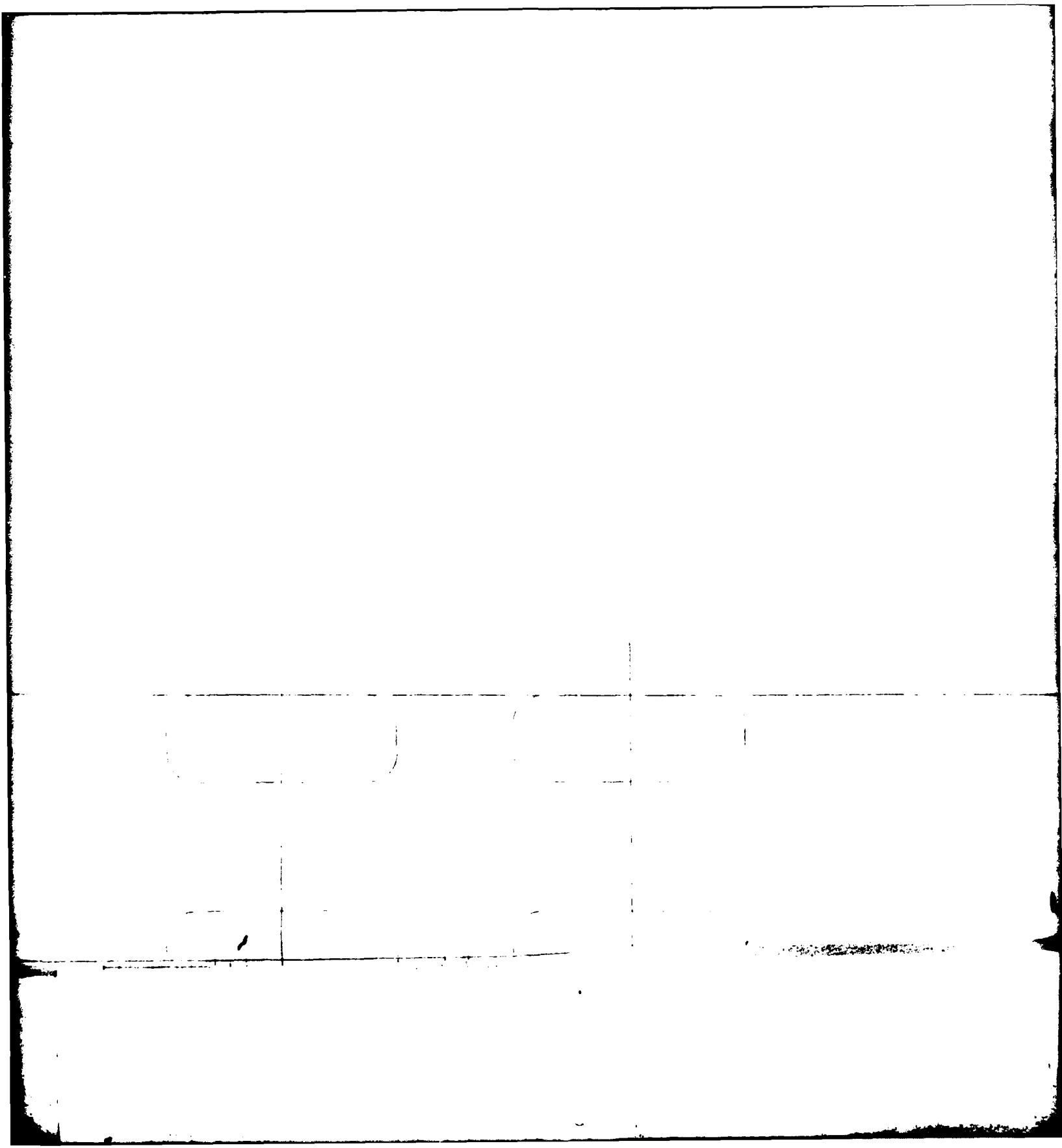

ZONE	LTR	

2

1

4

REVISIONS

ZONE	LTR	DESCRIPTION	DATE	APPROVED

H

G

7

F

E

B

8

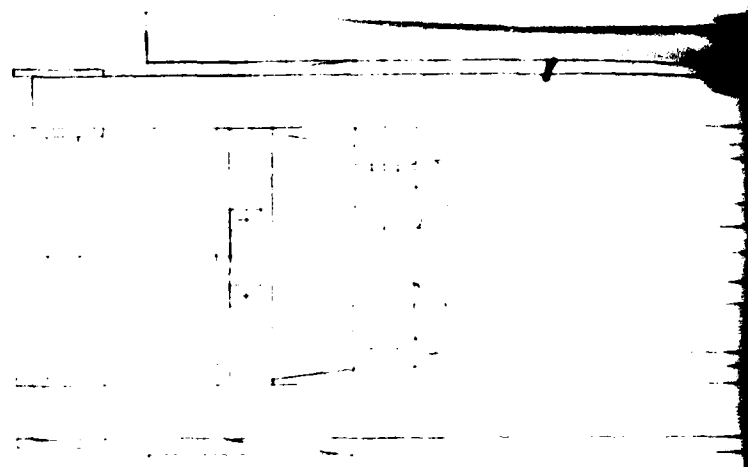

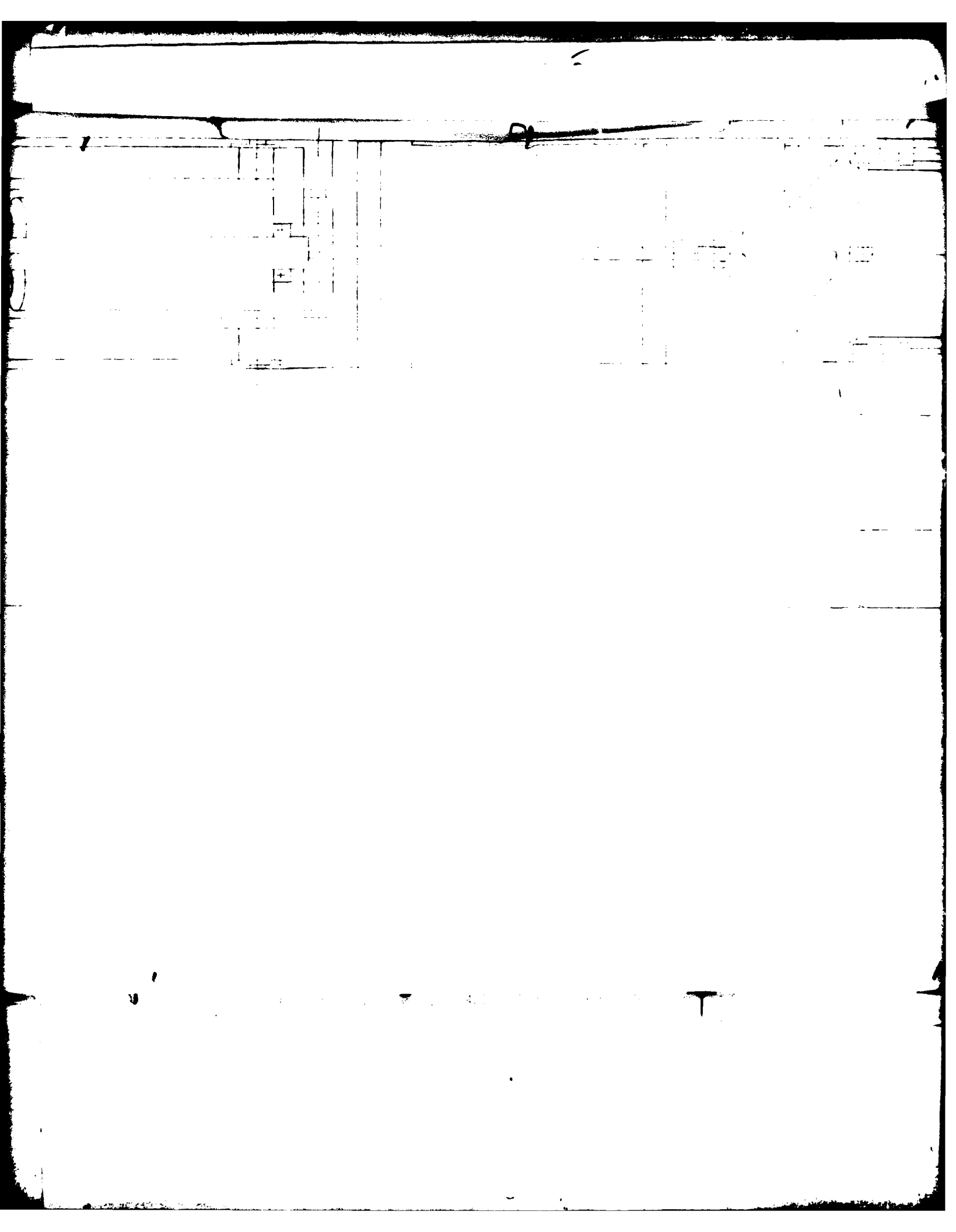

70

4

1

3

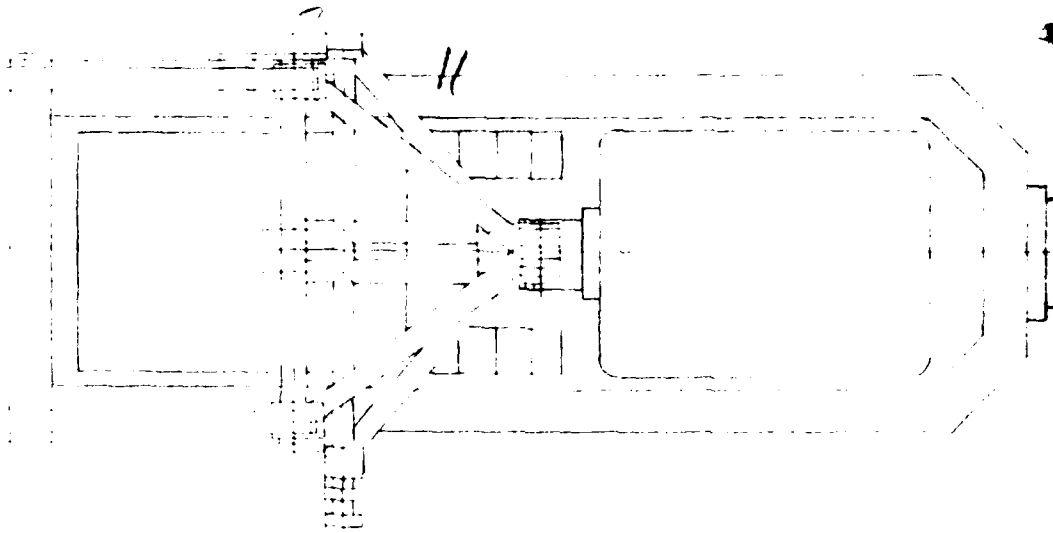

2

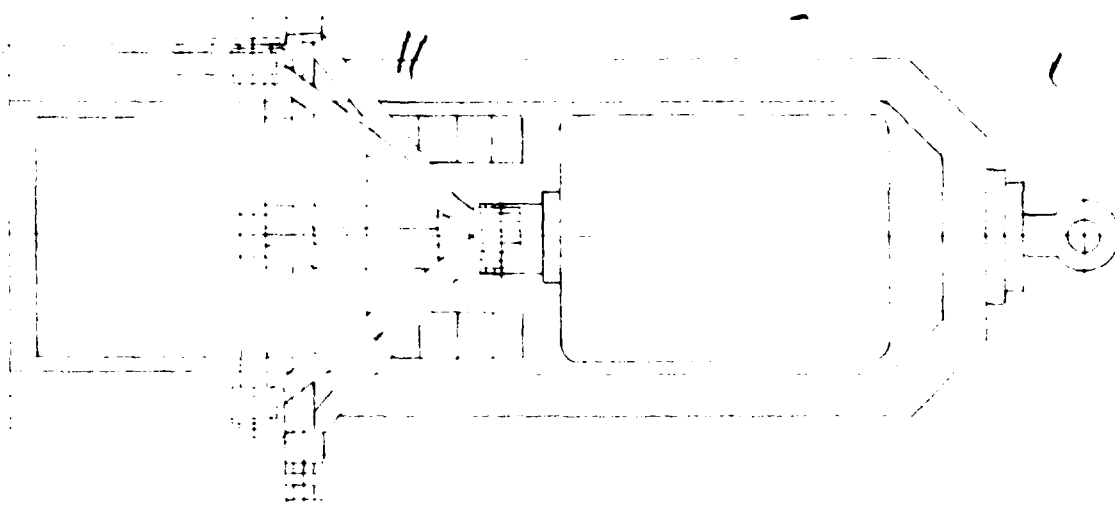

L-12



F

E

2

1



13

D

C

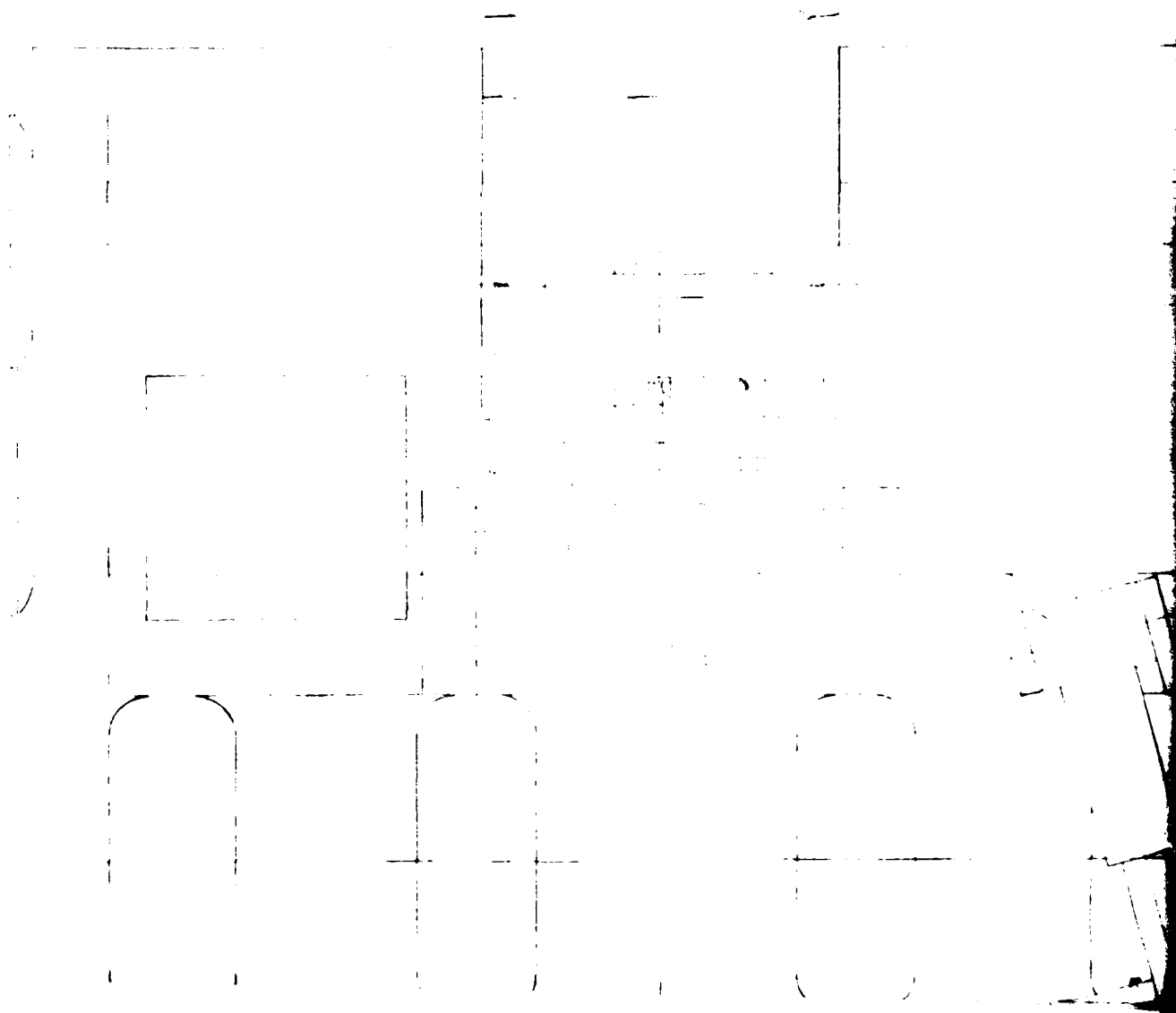

14

15

BOOK 100-100000
STANDARD

AIR
SEARCHED 20 22

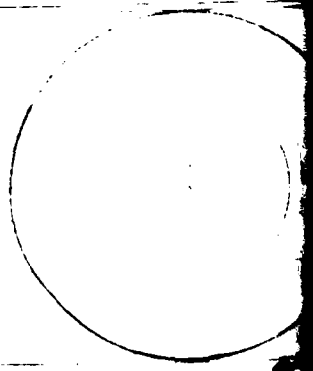

16

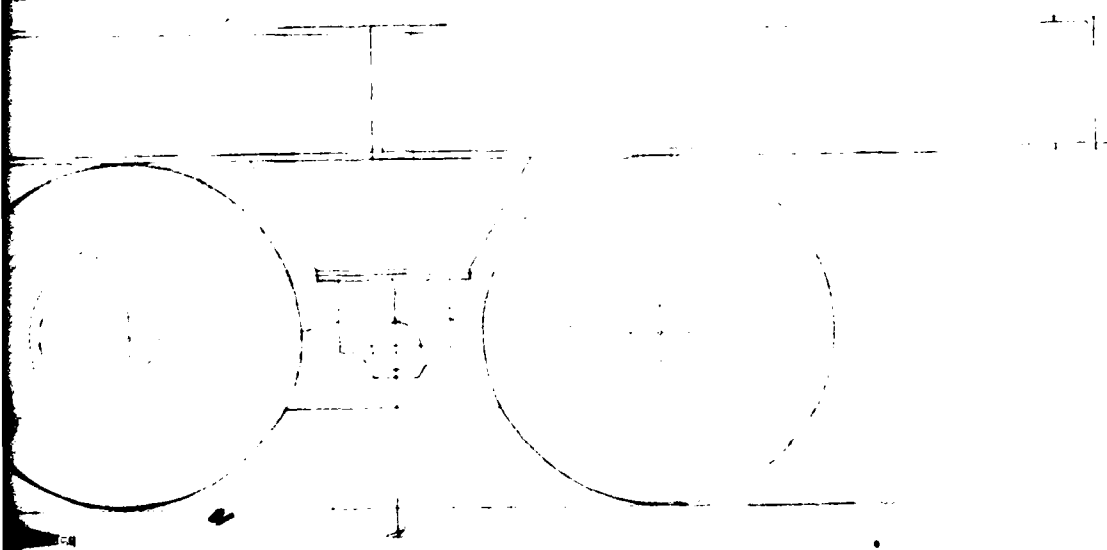

17

1000

1000

1000

1000

1000

1000

17

1

18

—

1

D



C

E

B

A

ADL-221-478-1M

8

14

7

7

20

6

SECTION E-E

NEW-A. CUTTING STONE

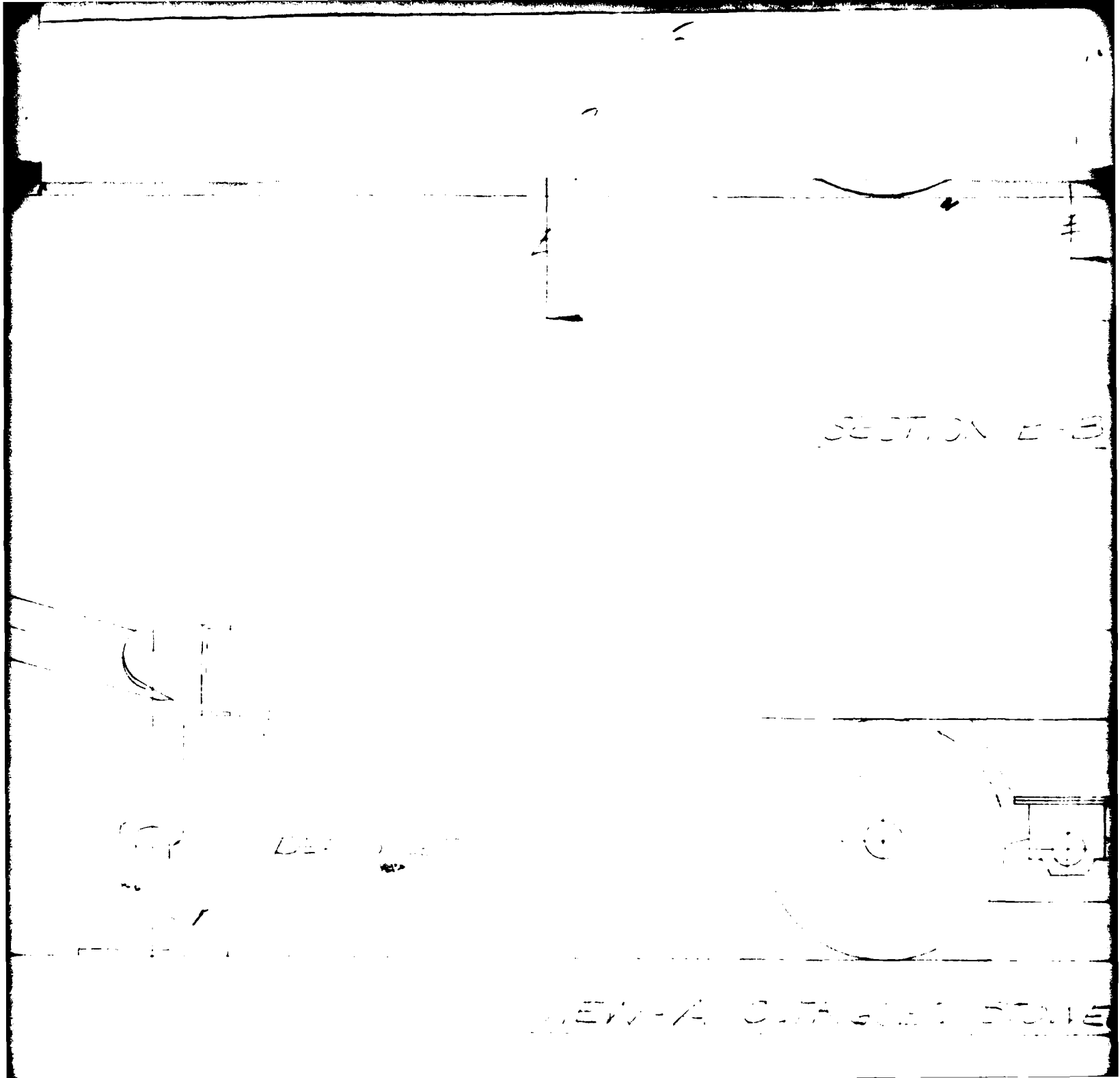

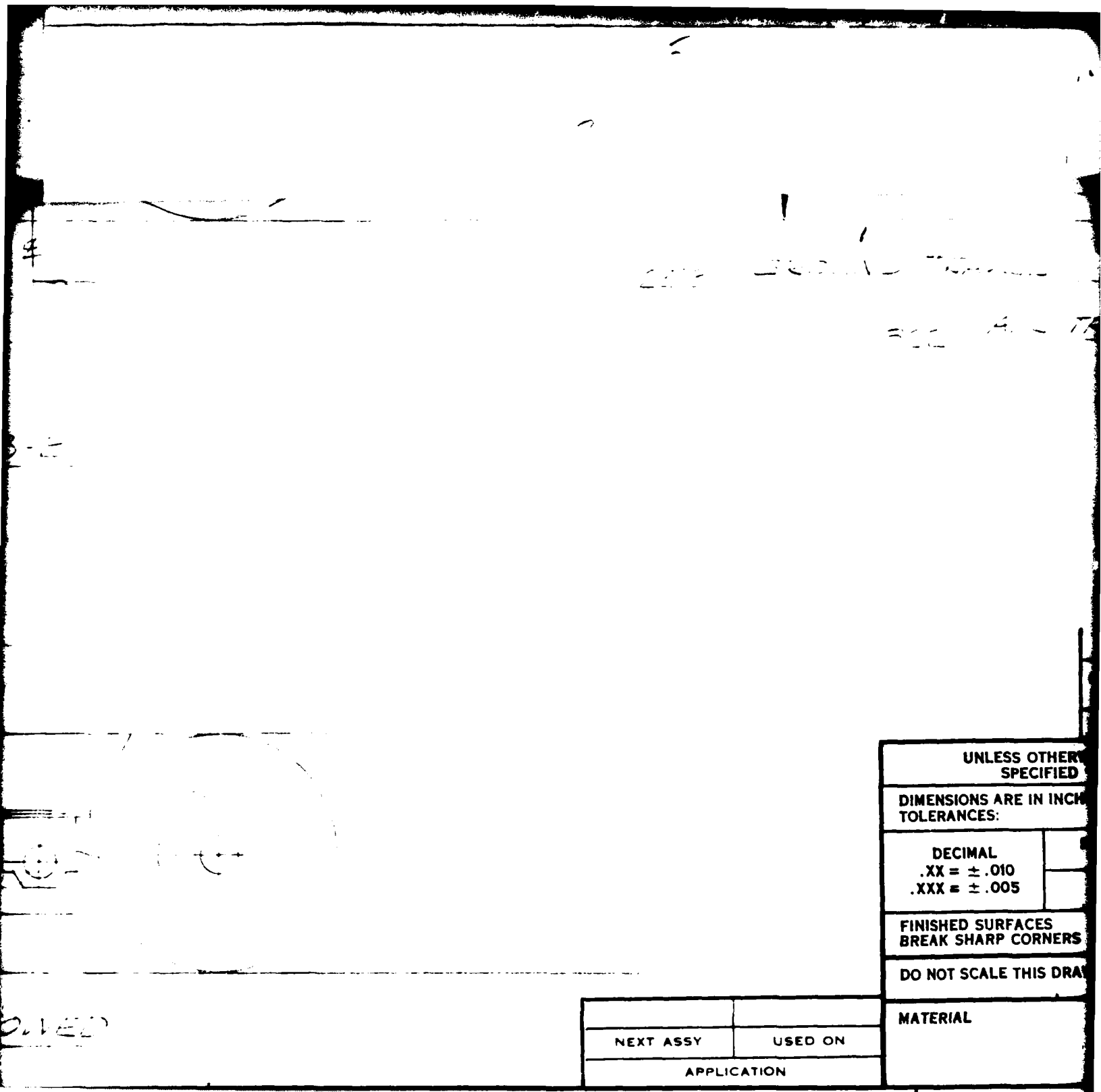

UNLESS OTHERWISE SPECIFIED

DIMENSIONS ARE IN INCH TOLERANCES:

DECIMAL
 .XX = ± .010
 .XXX = ± .005

FINISHED SURFACES
BREAK SHARP CORNERS

DO NOT SCALE THIS DRAWING

MATERIAL

NEXT ASSY	USED ON
APPLICATION	

0.125

ITEM NO.	QTY REQ	PART OR IDENTIFYING NO.	NOMENCLATURE OR DESCRIPTION	MATERIAL
----------	---------	-------------------------	-----------------------------	----------

LIST OF PARTS

UNLESS OTHERWISE SPECIFIED		ISSUE DATE:			Arthur D. Little CAMBRIDGE, MASSACHUSETTS	
DIMENSIONS ARE IN INCHES		DRAWN				
TOLERANCES:		CHECKED		CLASSIFIED ACCORDING TO PRELIMINARY DESIGN FOR THE SUBSTANCE OF		
DECIMAL X = ± .010 X = ± .005	FRACTIONAL ± 1/64	APPROVED				
FINISHED SURFACES RMS SHARP CORNERS						
ANGULAR ± 1°						
NOT SCALE THIS DRAWING				SIZE	CODE IDENT NO.	DRAWING NO.
MATERIAL				E	75629	4-93-105
		CASE		SCALE		SHEET

2

93
11

1

E
19
REV.

B

A

PART OR IDENTIFYING NO.	NOMENCLATURE OR DESCRIPTION	MATERIAL
-------------------------	-----------------------------	----------

LIST OF PARTS

ISSUE DATE:	 Arthur D. Little, Inc. CAMBRIDGE, MASSACHUSETTS 02140				
DRAWN <i>W.P.W.</i>					
CHECKED	<i>CLASSIFIED ASSAULT BRIDGE PRELIMINARY DESIGN TASK IIA. SUSPENSION BRIDGE</i>				
APPROVED					
	SIZE E	CODE IDENT NO. 75629	DRAWING NO. <i>4193-105</i>	REVISION	
CASE <i>300-200</i>	SCALE <i>1/2"</i>		SHEET <i>1 of 1</i>		

2

97

1

24

This drawing is not to be used for making reproductions thereof, or for making any apparatus based thereon, without first obtaining written authorization of Arthur D. Little, Inc.

H

G

7 H

2^o

6

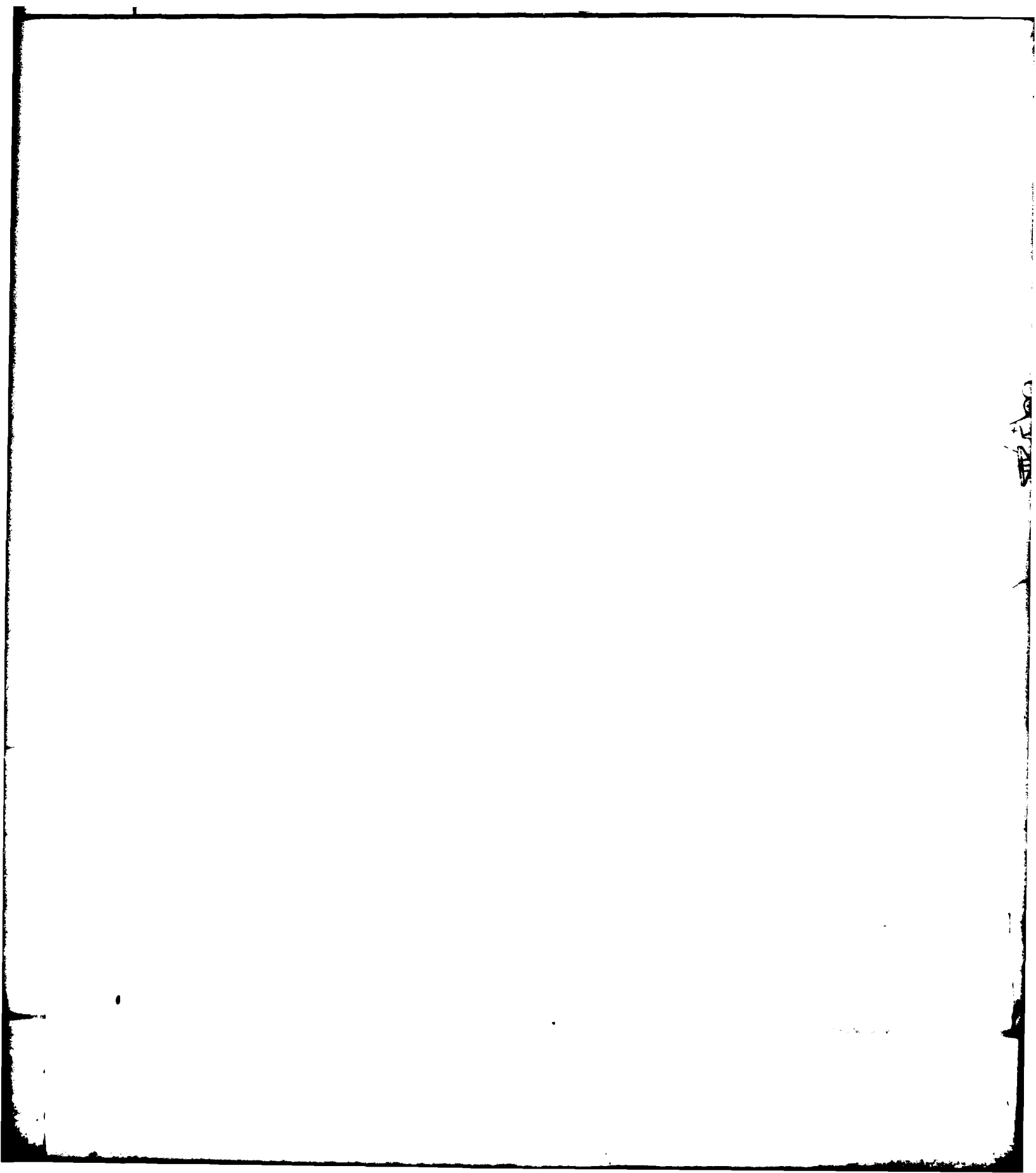

4

|

4

3

1
2
3
4
5
6
7
8
9
10

TRAILER POSITION

FILED

5 OF 5
AD
A115 131

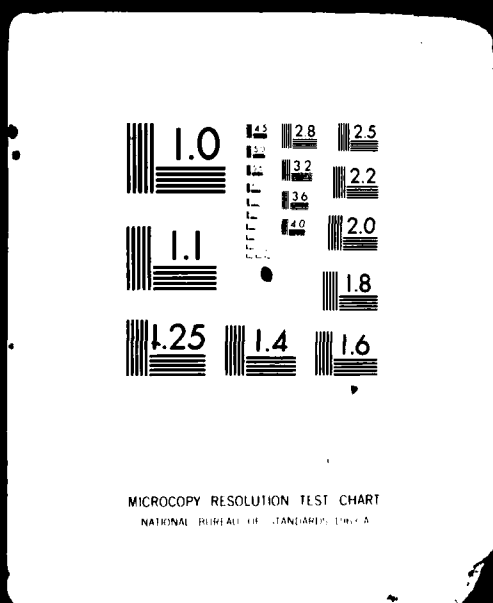

REVISIONS

ZONE LTR

DESCRIPTION

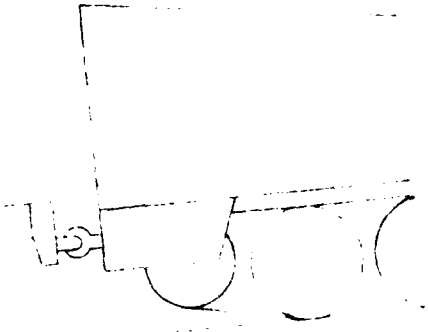

2

5

11

6

REVISIONS

ZONE	LTR	DESCRIPTION	DATE	APPROVED

H

G

7

F

E



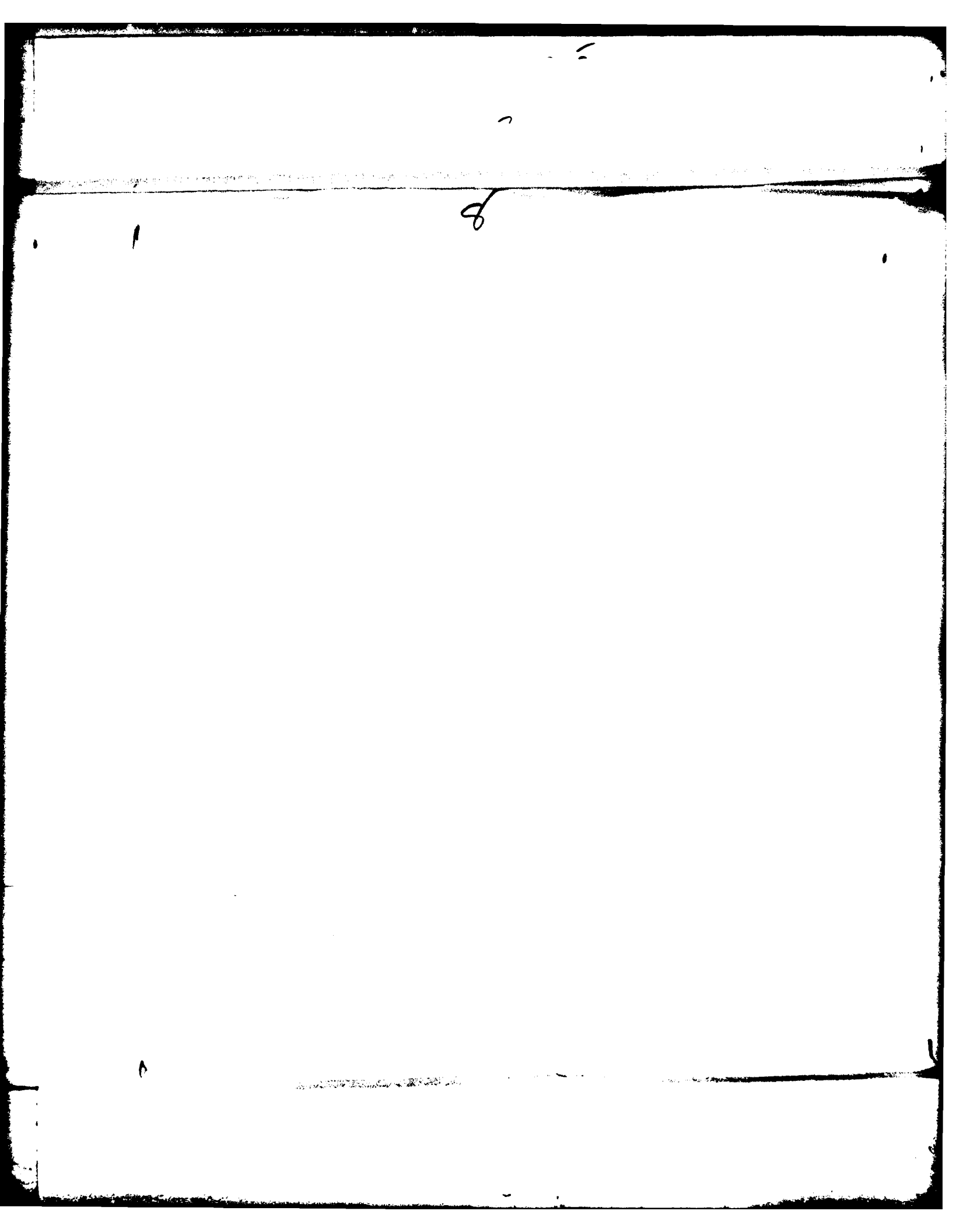

9

10

11
12
13
14
15
16
17
18
19
20
21
22
23
24
25
26
27
28
29
30
31
32
33
34
35
36
37
38
39
40
41
42
43
44
45
46
47
48
49
50
51
52
53
54
55
56
57
58
59
60
61
62
63
64
65
66
67
68
69
70
71
72
73
74
75
76
77
78
79
80
81
82
83
84
85
86
87
88
89
90
91
92
93
94
95
96
97
98
99
100

1

1

11

Handwritten scribbles or faint markings.

11

1

12

F

E

1

13

D

C

14

15

14

SOUTH BRIDGE AND WILSON
BRIDGE TO FLEMING

1/2

1/2

1/2

BRIDGE TO FARM - IN SOUTH - 20

1

1/2

17

17

1

18

D

C

B

A

ADL-221-478-1M

8

19

7

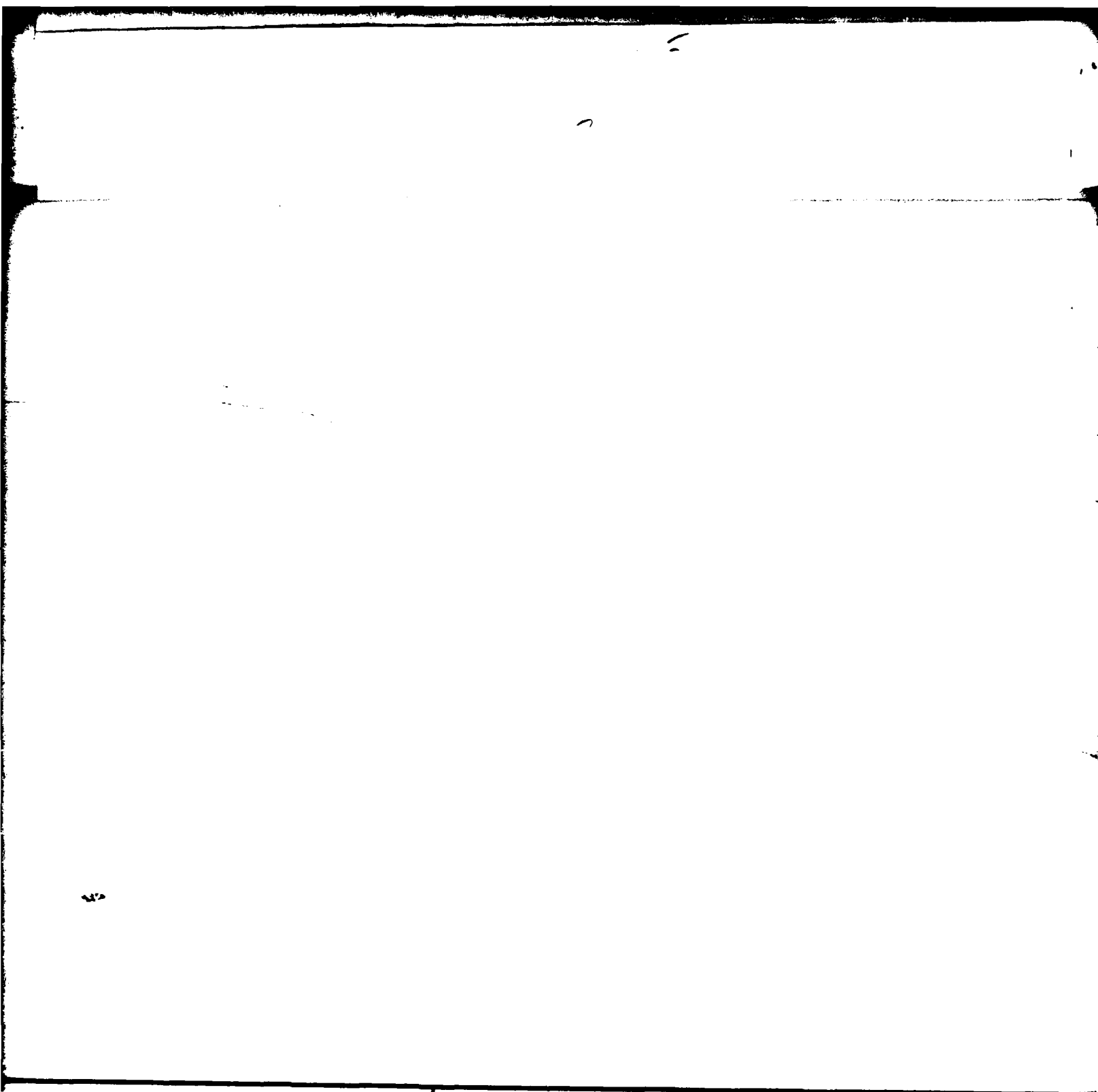

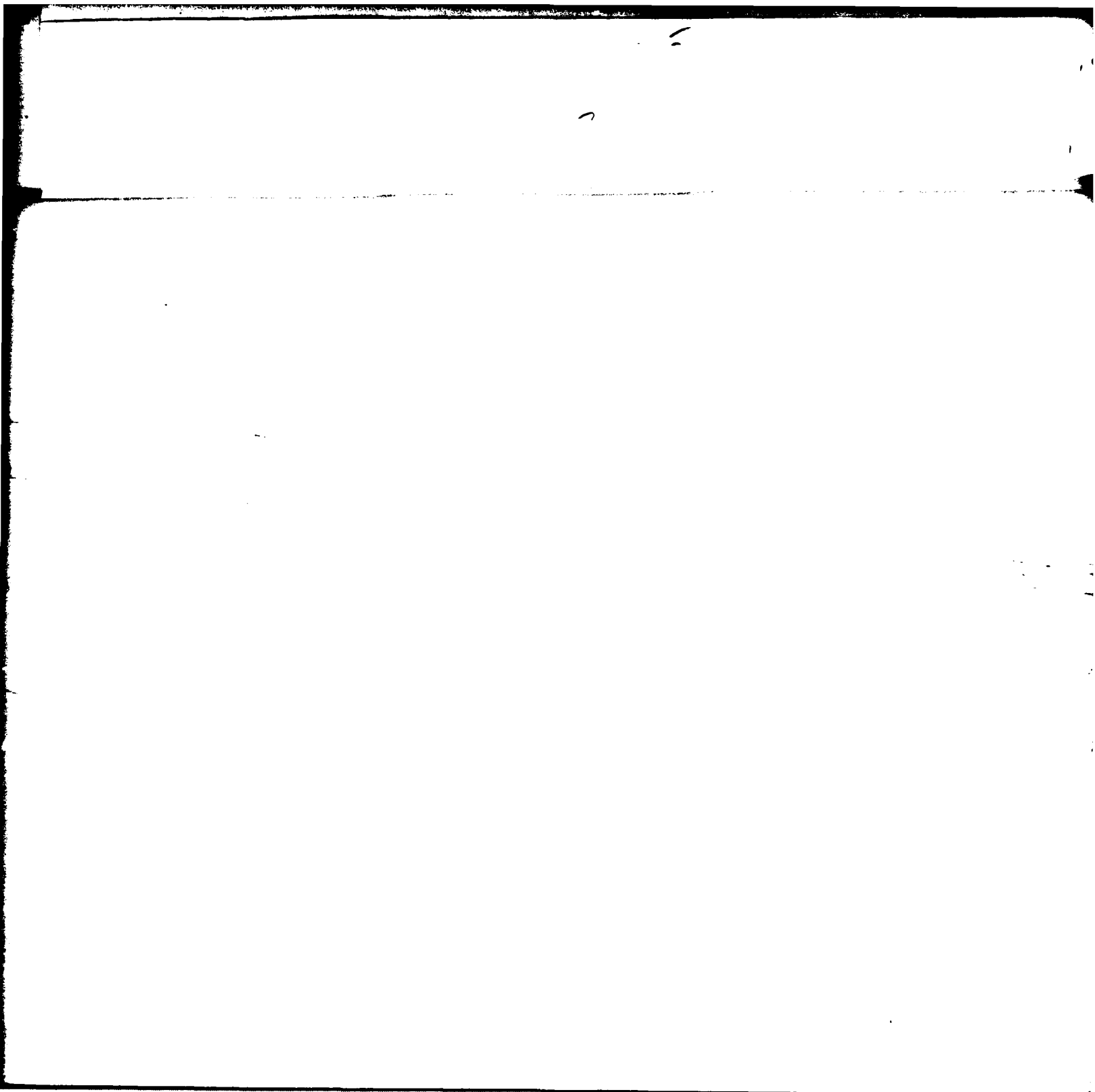

Handwritten notes and scribbles, possibly including the word "REPAIR" and other illegible markings.

BRIDGE IS FULLY EXTENDED & LET DOWN.

NEXT ASSY	U
APPLICATION	

ITEM NO.	QTY REQ	PART OR IDENTIFYING NO.	NOMENCLATURE OR DESCRIPTION
----------	---------	-------------------------	-----------------------------

LIST OF PARTS

UNLESS OTHERWISE SPECIFIED		ISSUE DATE:		
DIMENSIONS ARE IN INCHES TOLERANCES:		DRAWN 01/15/50	M	
DECIMAL .XX = ±.010 .XXX = ±.005	FRACTIONAL ±1/64	CHECKED		CLASSIFIED PRELIMINARY TASK I 5
	ANGULAR ±1°	APPROVED		
FINISHED SURFACES BREAK SHARP CORNERS RMS				
DO NOT SCALE THIS DRAWING				
MATERIAL		CASE 8661R-01	SIZE E	CODE IDENT NO. 75629

DOWN

BY	USED ON
APPLICATION	

SCALE 1/2" = 1"

E
4197-007
REV.

B

A

QTY REQ	PART OR IDENTIFYING NO.	NOMENCLATURE OR DESCRIPTION	MATERIAL
------------	----------------------------	--------------------------------	----------

LIST OF PARTS

ISSUE DATE: DRAWN <i>01/11/53</i> CHECKED APPROVED CASE <i>86618-01</i>	 Arthur D. Little, Inc. CAMBRIDGE, MASSACHUSETTS 02140						
				<i>CLASS BOASSAJLT BRIDGE PRELIMINARY DESIGN TASK I SUPERORS BRIDGE</i>			
	SIZE	CODE IDENT NO.	DRAWING NO.				REVISION
	E	75629	4197-007				
	SCALE <i>1/4" = 1'</i>	SHEET					

223

1 1 24

This drawing is not to be used for making reproductions thereof, or for making any apparatus based thereon, without first obtaining written authorization of Arthur D. Little, Inc.

H

G

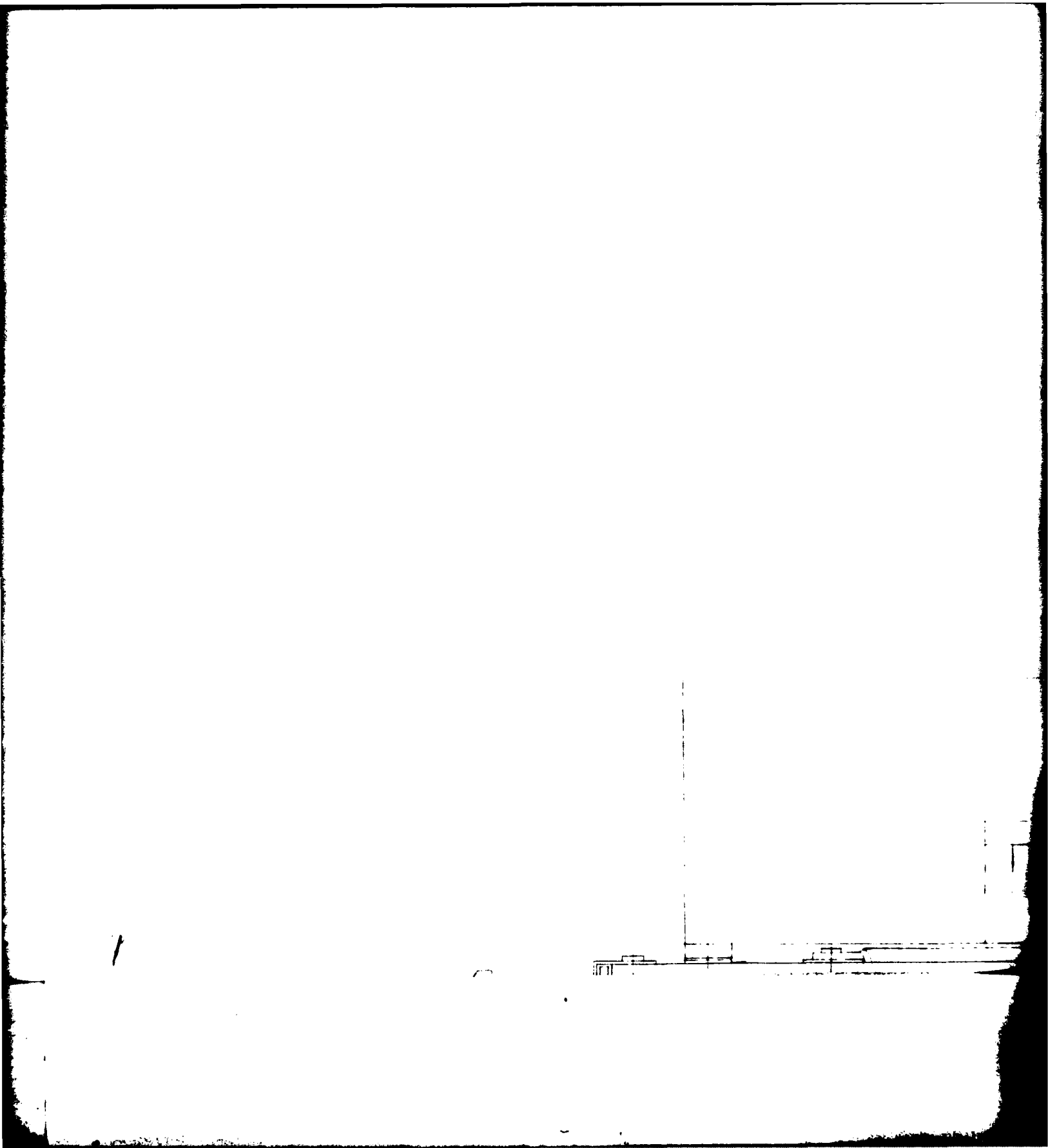

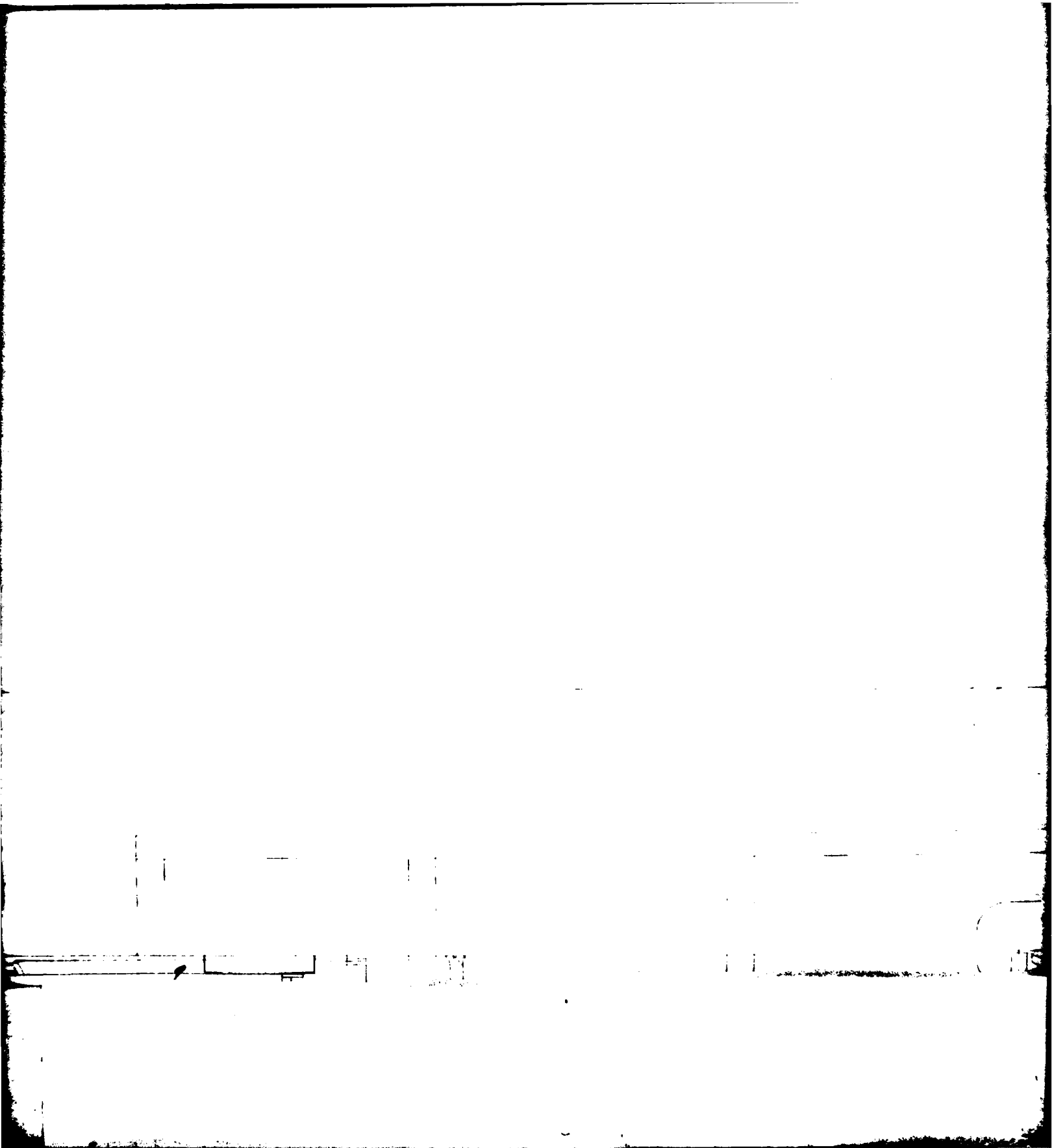

Handwritten text, possibly a signature or name, written in a cursive style across the middle of the page.

REV

ZONE LTR

DESCRIP

ZONE	LTR	DESCRIP

25

1 1

6

REVISIONS

ZONE	LTR	DESCRIPTION	DATE	APPROVED

H

G

1

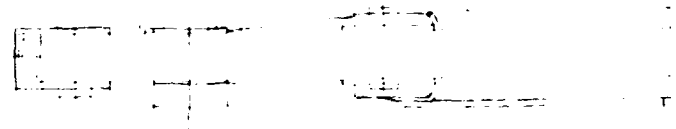
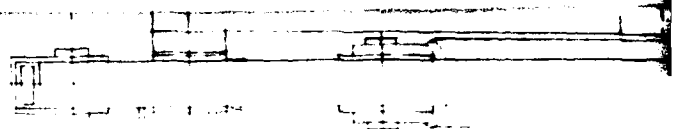

9

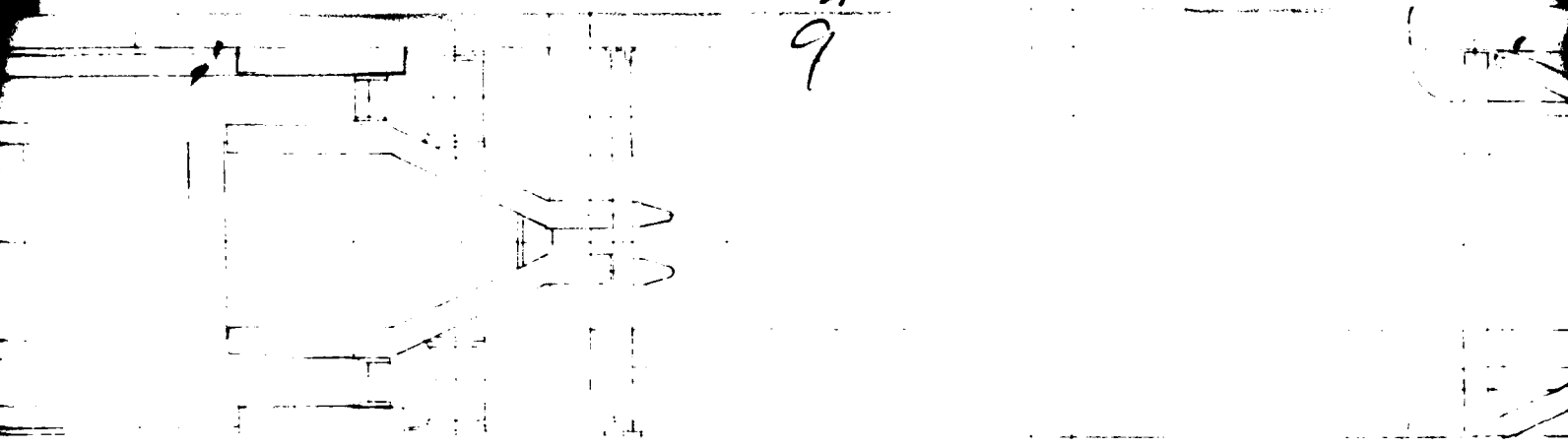

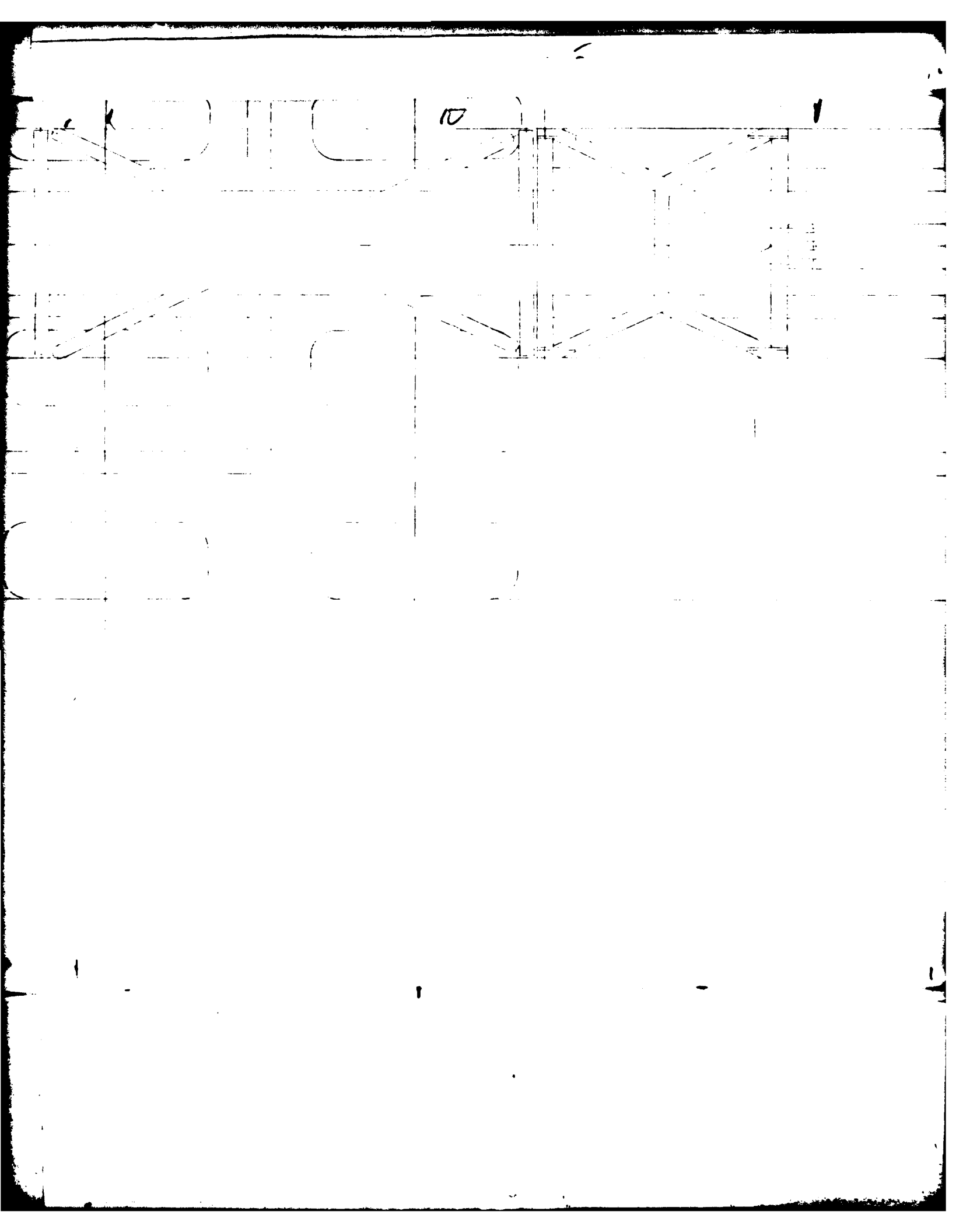

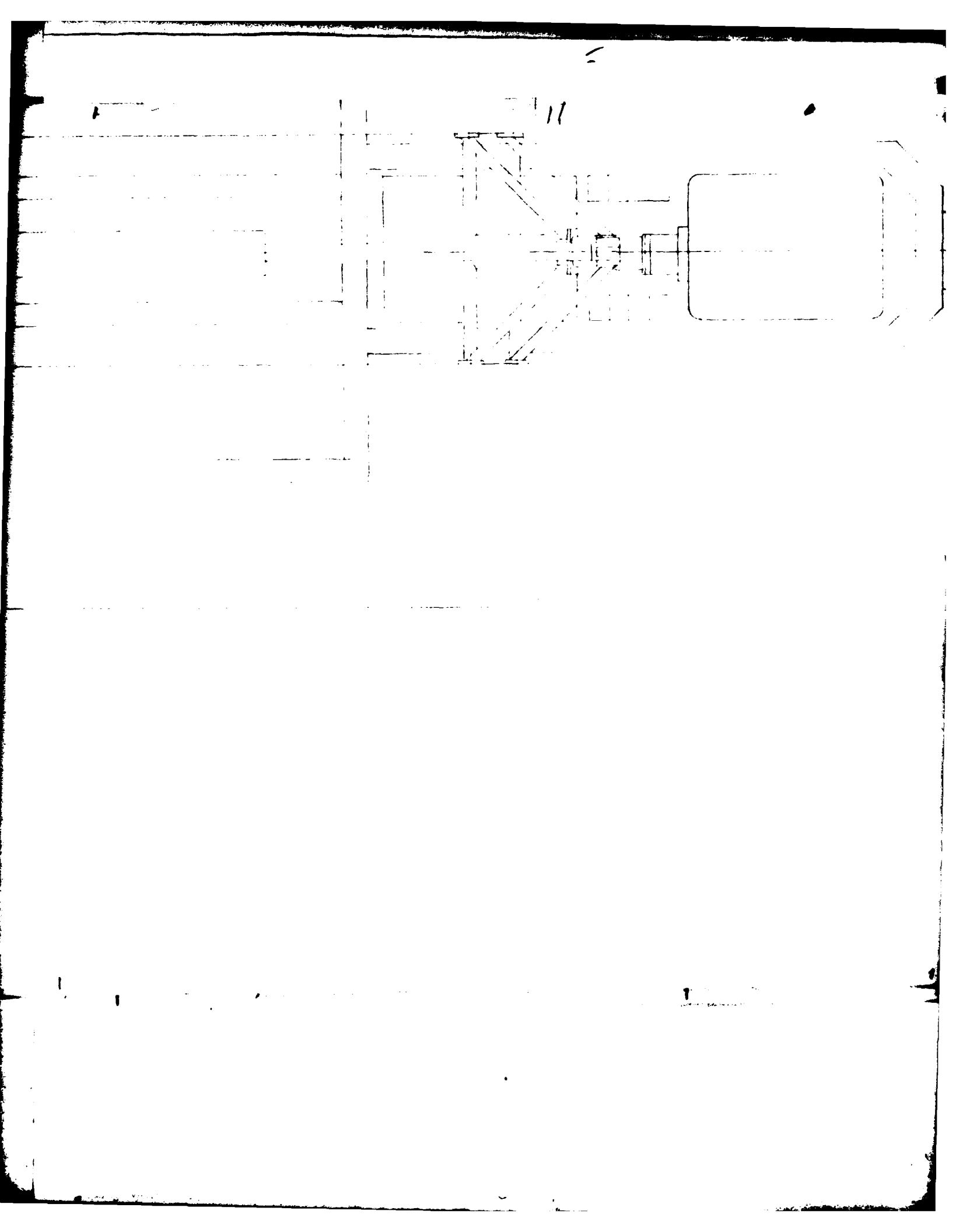

11

12

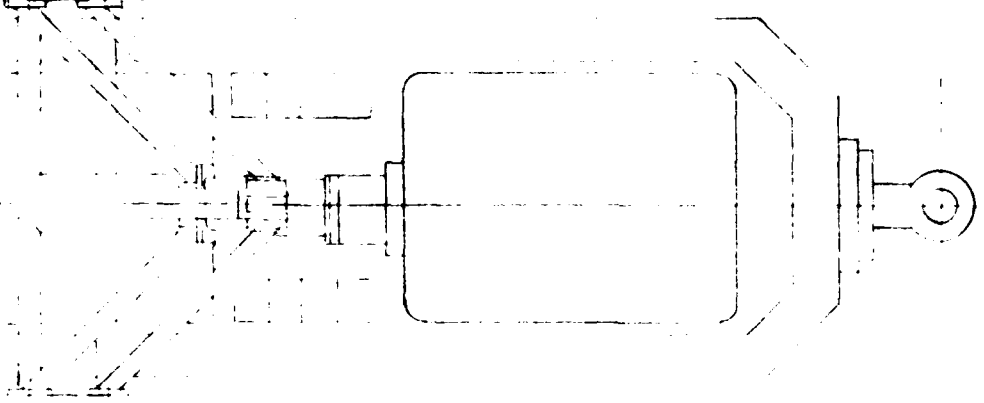

F

E



17

3.17.50
VIEW - A

11.7.50

D

C

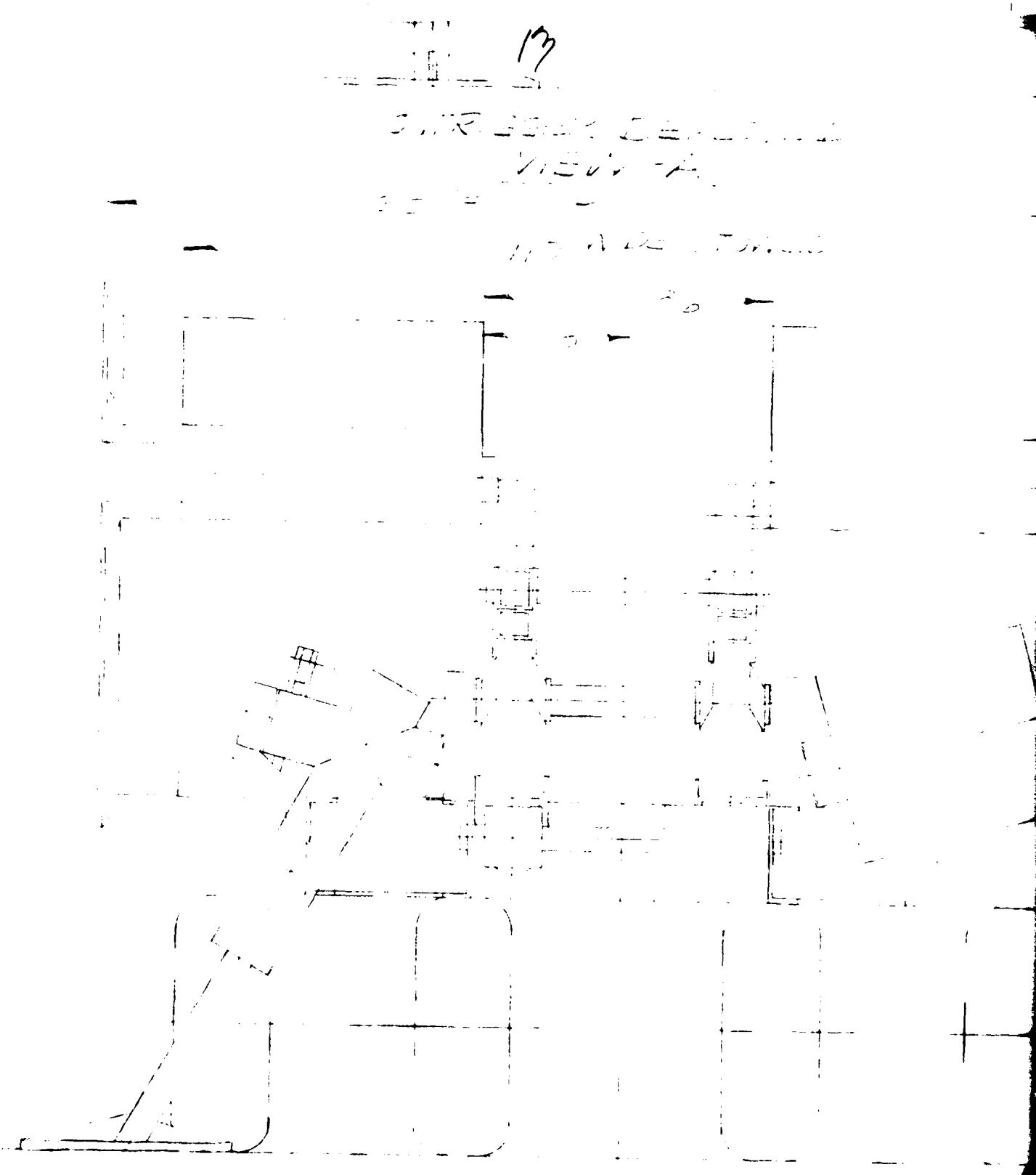

14

VIEW
A

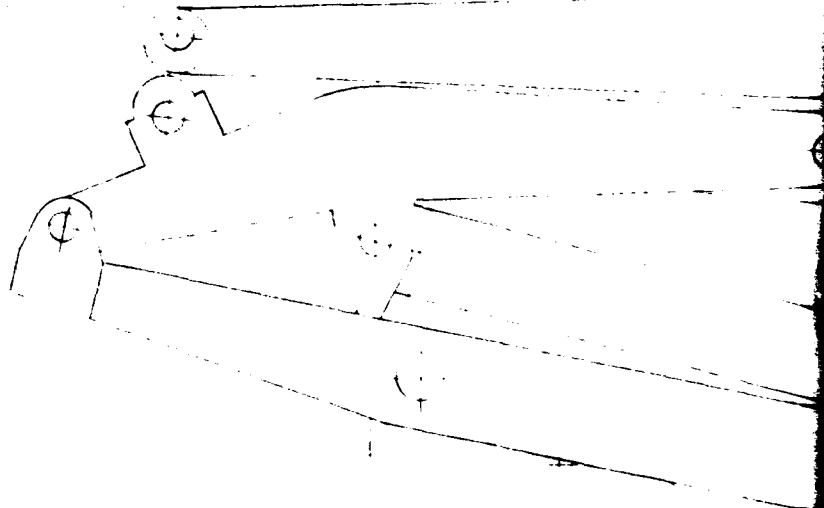

1

15²

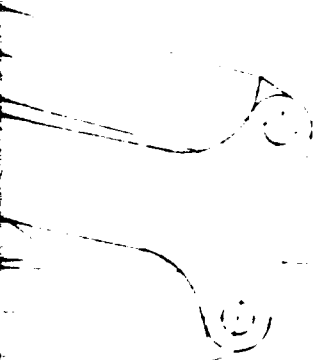
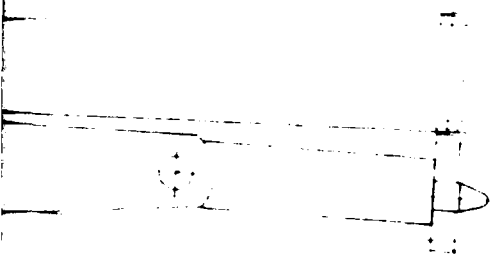

2700
5000

1000



16

821

1

2

FOR INFORMATION ON
STANDARD

1

4



17

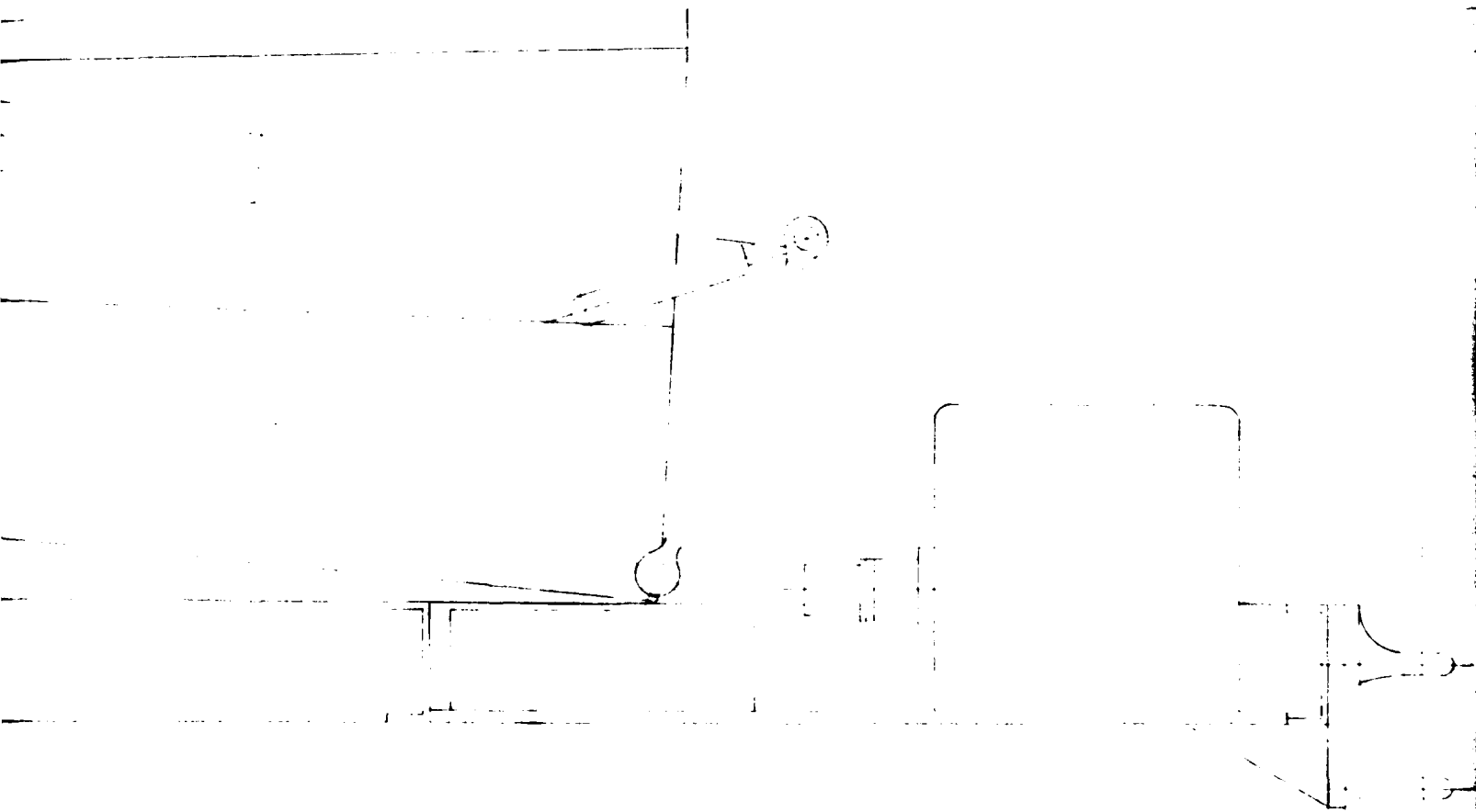

17

1

18

Y
Y

D

A

A

21

23

C

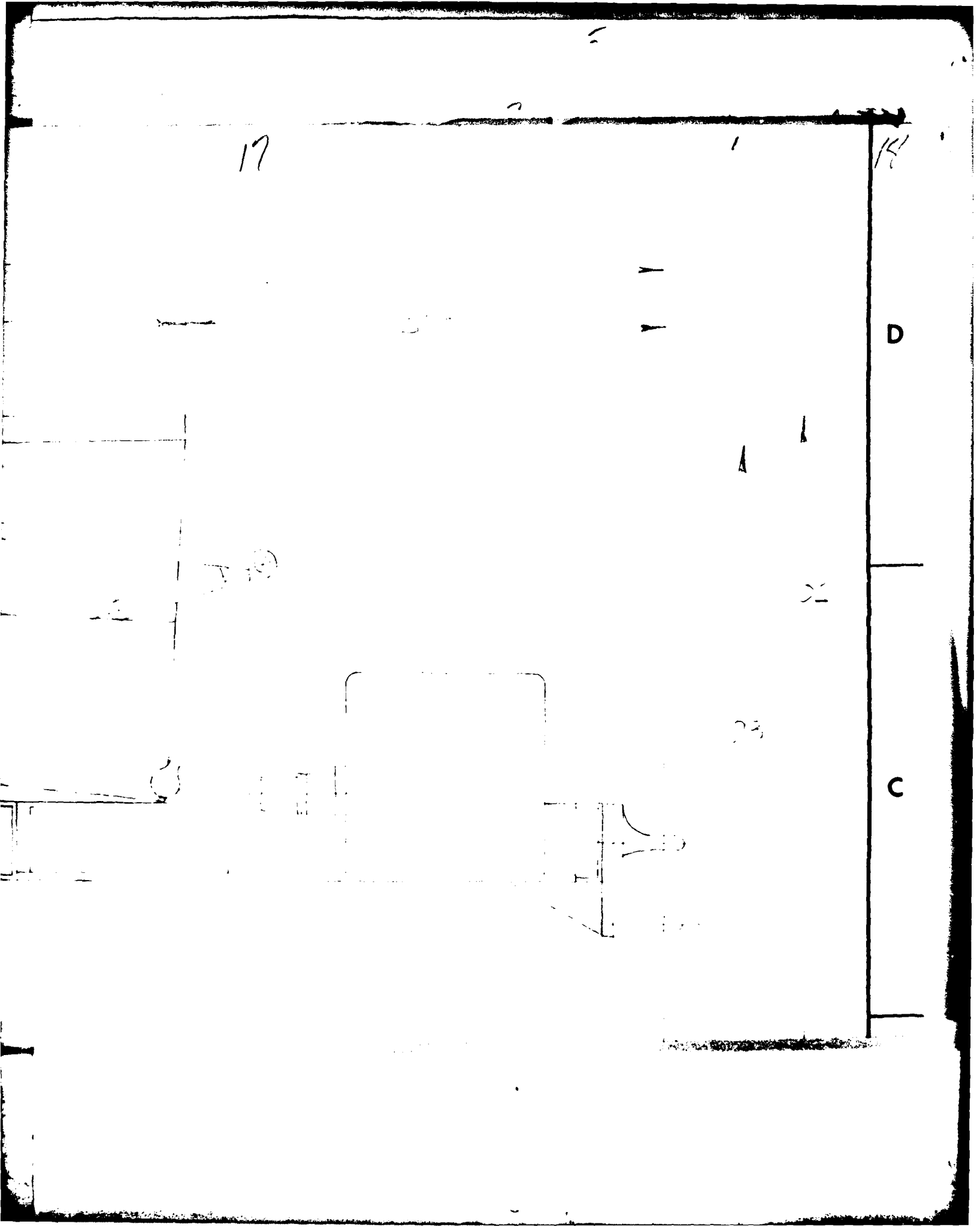

B

A

ADL-221-478-1M

8

1/9

7

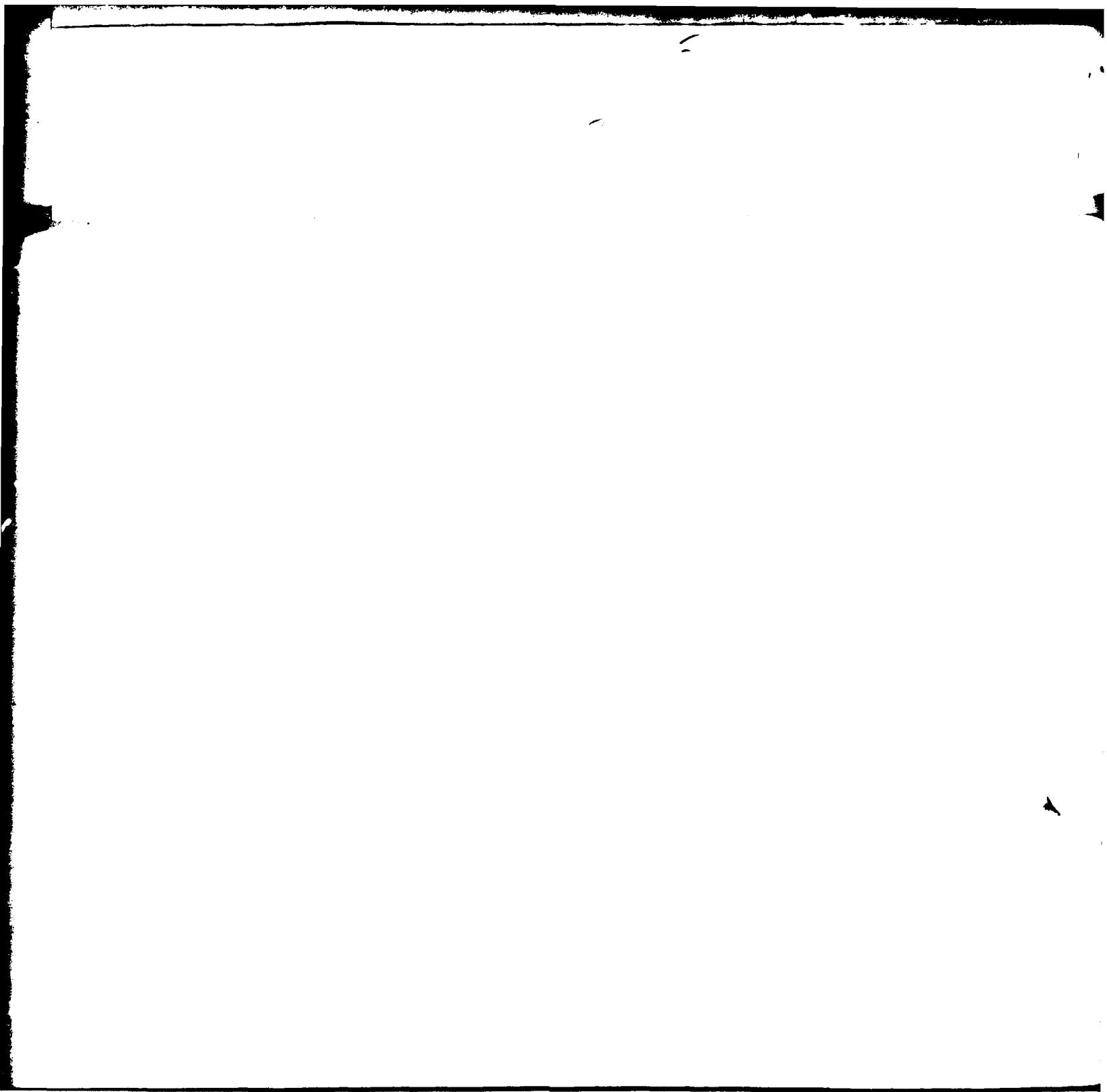

SECTION 5-5

L

215 085 12

215

DIMENS
TOLER

DE
.XX
.XXX

FINISH
BREAK

DO NOT

MATER

NEXT ASSY	USED ON
APPLICATION	

GROUND TOLERANCE
 FINISHED TOLERANCE

ITEM NO.	QTY REQ	PART OR IDENTIFYING NO.	NOMENCLATURE OR DESCRIPTION
----------	---------	-------------------------	-----------------------------

LIST OF PARTS

UNLESS OTHERWISE SPECIFIED		ISSUE DATE:		 Arthur D. Little CAMBRIDGE, MASS.
DIMENSIONS ARE IN INCHES TOLERANCES:		DRAWN <i>NEM</i>	<i>10-9-51</i>	
DECIMAL $.XX = \pm .010$ $.XXX = \pm .005$	FRACTIONAL $\pm 1/64$	CHECKED		<i>CLASSIFIED AS PRELIMINARY TASK I. SLIP</i>
FINISHED SURFACES RMS BREAK SHARP CORNERS		APPROVED		
DO NOT SCALE THIS DRAWING				
		SIZE	CODE IDENT NO.	DRAWN

E
 4/10/51
 REV.

B

A

PART OR IDENTIFYING NO.	NOMENCLATURE OR DESCRIPTION	MATERIAL
-------------------------	-----------------------------	----------

LIST OF PARTS

ISSUE DATE:		 Arthur D. Little, Inc. CAMBRIDGE, MASSACHUSETTS 02140		
DRAWN <i>NFM</i>	<i>10-9-51</i>			
CHECKED		<i>CLASS 30 ASSAULT AIR CUE PRELIMINARY DESIGN TASK I. SLIDING BRIDGE</i>		
APPROVED				
CASE <i>86000-1</i>	SIZE E	CODE IDENT NO. 75629	DRAWING NO. 4193-007	REVISION
	SCALE <i>3/4" = 1'</i>			SHEET <i>1 OF 24</i>

2

23

1

24



Arthur D Little, Inc.

Corporate headquarters
Cambridge, Massachusetts

Brussels
London
Madrid
Paris
Rio de Janeiro
San Francisco
São Paulo
Tokyo
Toronto
Washington
Wiesbaden

