

AD-A115 172

BATTELLE COLUMBUS LABS OH
DEVELOPMENT OF IMPROVED SEALS AND CLOSURES FOR DRY DIVING SUITS--ETC(U)
JAN 79

F/8 6/17

N61331-78-C-0026

NL

UNCLASSIFIED

191
A-115

END
DATE
FILMED
7-82
DTIC

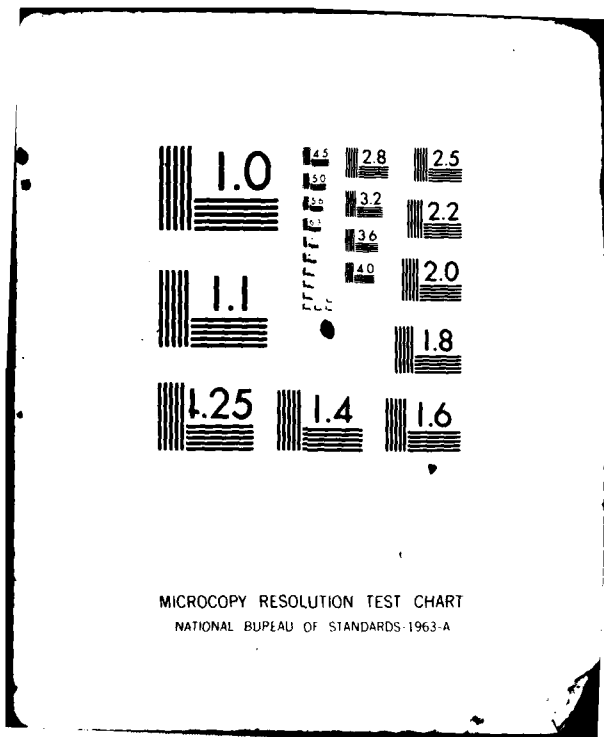

MICROCOPY RESOLUTION TEST CHART
NATIONAL BUREAU OF STANDARDS-1963-A



Battelle
Columbus Laboratories

Report

AD A115172

DTIC FILE COPY

S DTIC
ELECTE **D**
JUN 7 1982
E

This document has been approved
for public release and sale; its
distribution is unlimited.

FINAL REPORT

on

DEVELOPMENT OF IMPROVED SEALS AND
CLOSURES FOR DRY DIVING SUITS

to

NAVAL COASTAL SYSTEMS CENTER
PANAMA CITY, FLORIDA

January 31, 1979

ERIC
JAN 31 1982

BATTELLE
Columbus Laboratories
505 King Avenue
Columbus, Ohio 43201

1. Title
2. Author
3. Date

Accession For	
NTIS SERIAL	<input checked="" type="checkbox"/>
DISPATCH	<input type="checkbox"/>
Unannounced	<input type="checkbox"/>
Justification	<i>Its on file</i>
By	
Distribution/	
Availability Codes	
Dist	Avail and/or Special
A	

DTIC
COPY
INSPECTED
2

Approved by DC Doerschuk, DW Frink,

G-7060-1 (644)

DW Frink/JE Sorenson/644 Files
DC Doerschuk
Contracts/Files

January 31, 1979

Naval Coastal Systems Center
Panama City, Florida 32407

Attention Mr. G. Reule/341

Dear Mr. Reule:

Contract N61331-78-C-0026

Enclosed are five copies of the final design report. Today, we also shipped by separate parcel, the best effort sample suit developed by us for you. These are, respectively, Line Items 0002 and 0001AA and should complete our effort under this contract.

It has been a pleasure for the individuals at Battelle who were involved with this project to help you produce the best dry diving suit available. Technical inquiries pertaining to the report or suit should be directed to Mr. David C. Doerschuk at (614)424-7825.

Very truly yours,

D. W. Frink
Manager
Equipment Development Section

DWF:lds

Enclosures (5)

TABLE OF CONTENTS

	<u>Page</u>
INTRODUCTION.....	1
SUMMARY.....	1
CONCLUSIONS.....	2
RECOMMENDATIONS.....	2
TECHNICAL ACTIVITY.....	3
FINAL DESIGN.....	6
Donut Wrist Seal.....	6
Donut Neck Seal.....	6
Multiple Lip Wrist Seal.....	6
Closures.....	10
TEST PROCEDURES AND RESULTS.....	10
Leak Testing.....	10
Vacuum Leak Data.....	10
Stretch Testing.....	13
Underwater Suit Testing Results.....	18

LIST OF FIGURES

Figure 1. Details for Suit No. 1.....	7
Figure 2. Suit No. 1.....	8
Figure 3. Details for Suit No. 2.....	9
Figure 4. Suit No. 2.....	11
Figure 5. Vacuum Leak Tester.....	12

LIST OF FIGURES
(Continued)

	<u>Page</u>
Figure 6. Wrist Seal Stretch Tester.....	14
Figure 7. Measured Wrist Seal Pressure.....	15
Figure 8. Neck Seal Stretch Tester.....	16
Figure 9. Measured Neck Seal Stretch.....	17

FINAL REPORT

on

DEVELOPMENT OF IMPROVED SEALS AND
CLOSURES FOR DRY DIVING SUITS

to

NAVAL COASTAL SYSTEMS CENTER
PANAMA CITY, FLORIDA

from

BATTELLE
Columbus Laboratories

January 31, 1979

INTRODUCTION

This report describes technical activity to conceive, design, develop, and test dry diving suits with advanced closures, wrist seals, and neck/face seals. Leakage of closure or seals impedes diver efficiency by reducing thermal integrity and can be dangerous. The fit of seals and closure location are also important to diving efficiency. Battelle considered these problems in depth and attempted to produce a prototype suit with improved closures and seals.

SUMMARY

Hypothetical approaches were evaluated first as ideas, then as models on special apparatuses, and finally as dry diving suits underwater. Parameters such as incipient leakage vacuum levels and seal "stretch" were developed to compare the new ideas and conventional designs. A materials evaluation was also conducted for the applications and the new designs were built with optimal materials. A standard hooded Viking suit equipped with Viking face seal, riveted tooth gas sealing zipper extending from the right side of head to right knee, and labyrinth type multiple lip neoprene wrist seals was the best effort suit delivered to the U. S. Navy.

CONCLUSIONS

1. Sodium bicarbonate blown neoprene wrist and neck seals provide the most skin compliant material we could find of all commercially available diving suit seals and experimental materials tested. The open cell neoprene foam can be dip coated in neoprene latex to provide hermetic sealing, however we conclude that foam materials for seals cannot outperform seal configurations made of solid materials.

2. Solid neoprene rubber can be injection molded to produce wrist seals with increased resistance to puncturing and reduced maintenance over commercially available seals constructed of solid elastomeric. Both the standard Viking latex (a fragile but very effective seal) wrist seal and the developed solid neoprene multiple lip wrist seal withstood any constant leaks when subjected to an outside bias pressure of 36 inches of water. The multiple lip wrist seal can be donned quicker and doffed in the same amount of time as the standard Viking latex. The neoprene is more resistant to solvent than the latex. The multiple lip seal is easy to clean, its multiple chambers resist the passage of particles, however, long term skin comfort of this configuration remains to be tested by the U. S. Navy.

3. A riveted tooth gas sealing zipper produced by New Zipper, Ltd., England was found to perform better in all dry diving suit applications than any experimental design or other closure. A long zipper extending from the right side of the head to right knee was found to provide quick one man don and doff times, however, this closure location prevented the use of a standard Viking style inner hood as originally intended. A standard Viking combat swimmer style face sealed hood was found to work well and be compatible with the new closure location. This particular face seal is not normally intended for use with a pressurized suit.

RECOMMENDATIONS

1. The use of gloves with a multiple lip wrist seal should be pursued from a design standpoint of attaching gloves to external portions of the neoprene seal.

2. The use of riveted tooth zipper closure opening from knee up front to side of diver's head should be investigated for applicability to combat swimming requirements. Also, zipper locations that extend below the knee should be investigated for reduced don/doff effort and any restrictions in mobility.

3. Materials for dry diving suit and seal repair should be investigated for application underwater. Also maintenance supply kits should be assembled to repair and maintain the suit delivered at the end of this program for U. S. Navy field trials.

TECHNICAL ACTIVITY

The seal and closure concepts were evaluated using a weighted matrix. Approaches using special tapes and adhesives bonding directly to diver's skin were eliminated due to low scores in comfort, ease of operation, and diver acceptance. Approaches selected for modeling wrist seals were inflatable, open cell foam, and multiple lip. The approach selected for neck modeling was open cell foam. An inflatable neck seal was eliminated due to the small amount of pressure that can be applied to the neck area without impeding blood flow. Interlocking zipper closures were found to pull apart at low force especially when not laying flat. Semi-rigid waist closures were considered too bulky. The top rated closure concept employed a zipper in the suit front the extended from knee up to the side of the diver's head. This would allow easy, one-man use and ventilation before diving. This zipper location was intended for use with Viking's new hood-type, face-sealed suit which presently has a zipper up the diver's back.

The materials specialists at Battelle searched for existing materials that might best be used in the concept applications. Elastomers, zippers, and adhesives were searched. It was determined that a zipper made by New Zipper, Ltd. with each tooth riveted to the base material was not only similar to, but superior to the zippers found on present suits. The main problem with present suit zippers is that divers will use oil to lubricate the zipper which decomposes the rubber base material allowing the teeth to be pulled out. This problem is eliminated with the riveted tooth zipper.

Natural rubber sheet, elastomer coated fabric, smooth skin open cell neoprene, nylon sided open-cell neoprene, and nylon velcro were selected for use in modifying existing seals and modeling new seals. Samples of these materials were collected for initial evaluations. Also, six dry diving suits were received from NCSL for comparison during this program.

Of the different adhesives evaluated for bonding elastomer coated fabric to natural rubber sheet, the Viking repair kit adhesive and Scotch 1711 adhesive provided bonding which should perform adequately in dry diving suit applications.

Test rigs were developed to produce reliable data and a series of three tests were conceived to evaluate wrist and neck seals. The tests were performed on Viking, Unisuit, and Supersuit dry diving suits. The tests evaluated (1) Sealing pressure exerted on the diver's wrist, (2) sealing pressure exerted on the diver's neck, and (3) ability of wrist seals to withstand vacuum air leaks.

A decision was made to pursue three types of seals and to build three models. The first type seal was the multiple lip seal which is intended for the wrist only. A design was made and an aluminum mold was built for this model. The second type seal was the foam "donut" configuration which is intended for either the neck or the wrist. Molds were designed for these seals. The third type seal to be modeled was the inflatable seal which was used with a velcro strap to provide sealing pressure in the event of rupture. Several models were made of this seal in a wrist version, with promising results.

Development continued in an effort to fabricate a satisfactory foam neck seal, inflatable wrist seal, and multiple lip wrist seal. The inflatable wrist seal was made by a dipping process using neoprene latex, the foam neck seal is neoprene that was blown in a hot aluminum mold using sodium-bicarbonate, and the multiple lip wrist seal was produced on a rubber injection machine using high molecular weight neoprene. The first rubber injection molding showed this fabrication procedure to have good potential for producing a satisfactory seal.

The inflatable wrist seal was tested on the vacuum leak tester to an incipient leak vacuum level of 3 to 4 inches of water with 15-20 inches of water inflation pressure. In order to make this seal work we had to wrap it with velcro straps. As we could not make this seal work without a relatively high inflation pressure we eliminated the inflatable seal from further consideration.

Successful development was completed on the multiple lip wrist seal. The donut wrist seal and donut neck seal performed favorably in stretch and compression tests, however, development work continued on these seals in order to obtain a sealed skin on its outer surfaces.

At the design presentation meeting it was decided that two suits with experimental closures and seals would be built for final testing. One suit is on a Viking chassis with Viking hood and face seal, multiple lip wrist seals, and a riveted tooth zipper closure extending from front thigh to side of head. The other suit is a on Viking chassis with donut neck and wrist seals (with sealed outer skin) and a riveted tooth zipper closure extending from front thigh to diver's upper chest.

Experiments were conducted with silicone for sealing the donut seal exteriors, however, it was found that the silicone upon hardening significantly reduced the elasticity of the seal, in fact a silicone coated neck seal could not be donned. However, it was found that dipping the open cell neoprene donut seals into neoprene latex resulted in bonding of the two materials and a sealed surface. Also, the dipping and a subsequent heat aging 2 hours at 80°C resulted in no significant changes in elasticity of the neck seal when tested upon the stretching apparatus.

The suits were tested in the 33 foot pool with sanded water. The hooded suit performed satisfactorily; the suit equipped with donut seals did not. Test results are included in the next section of this document. The hooded suit was shipped to NCSC as a best effort sample suit.

FINAL DESIGNDonut Wrist Seal

The Donut Wrist Seal is shown in detail in Figure 1. It consists of the solidum biocarbonate blown neoprene seal which has been tested to 700 psi without showing significant deformation. It is attached to the suit arm material, with the attachment sealed and strengthened by non-stretch tape. The seal is tapered to allow easy donning and soft enough to allow easy doffing by reversal. The thick seal is designed to allow a wide range of wrist sizes to be used within acceptable tightness. The large size seal is 2.75 inch long with a 4.0 inch OD x 1.7 inch ID and an inner surface length of 1 inch.

Donut Neck Seal

The Donut Neck Seal parts consist of the same material as the Donut Wrist Seal and are shown in Figure 2. The design is similar also with a tapered donning entry area. The large size neck seal is 2.75 inch long with an 8.1 inch OD x 4.5 inch ID and an inner surface length of 1 inch.

Multiple Lip Wrist Seal

The Multiple Lip Wrist Seal is shown in Figure 3 and constructed of solid neoprene. It is 3 inches long x 3.5 inch OD with four sealing lips (starting at the hand) of 1.8 inch ID, 1.75 inch ID, 1.8 inch ID, and 2.0 inch ID; all walls are .060 inch thick. The lips are spaced 0.5 inches apart and taper in a similar configuration to a human wrist. The seal is attached to the suit by adhesive, with the attachment being strengthened by non-stretch tape. The seal is donned by simply passing the hand through; doffing is most easily accomplished by pulling the seal inside out as the wrist is retracted. Don/doffing is made easier by the use of water lubricant.

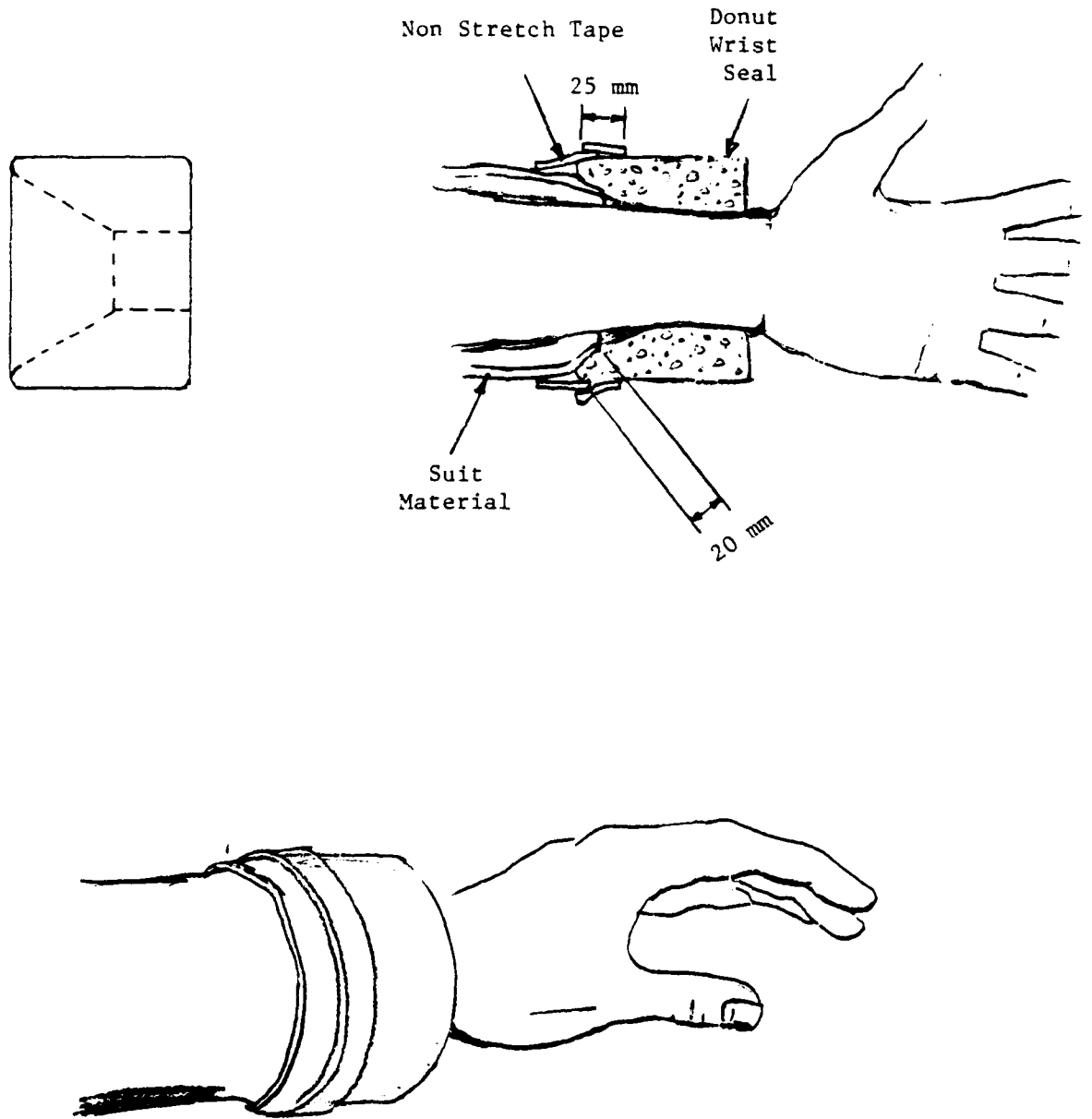

FIGURE 1. DETAILS FOR SUIT NO. 1

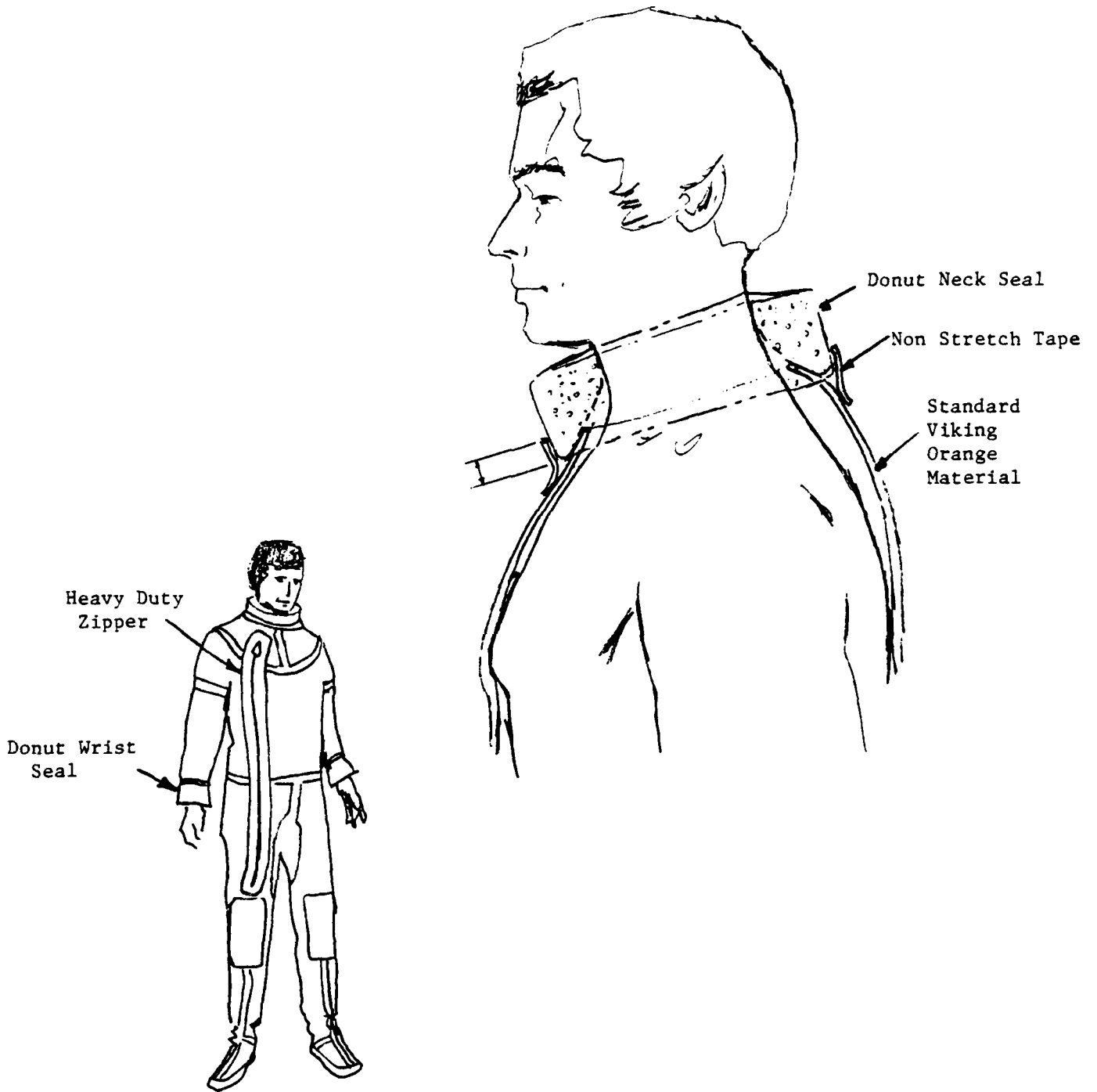

FIGURE 2. SUIT NO. 1

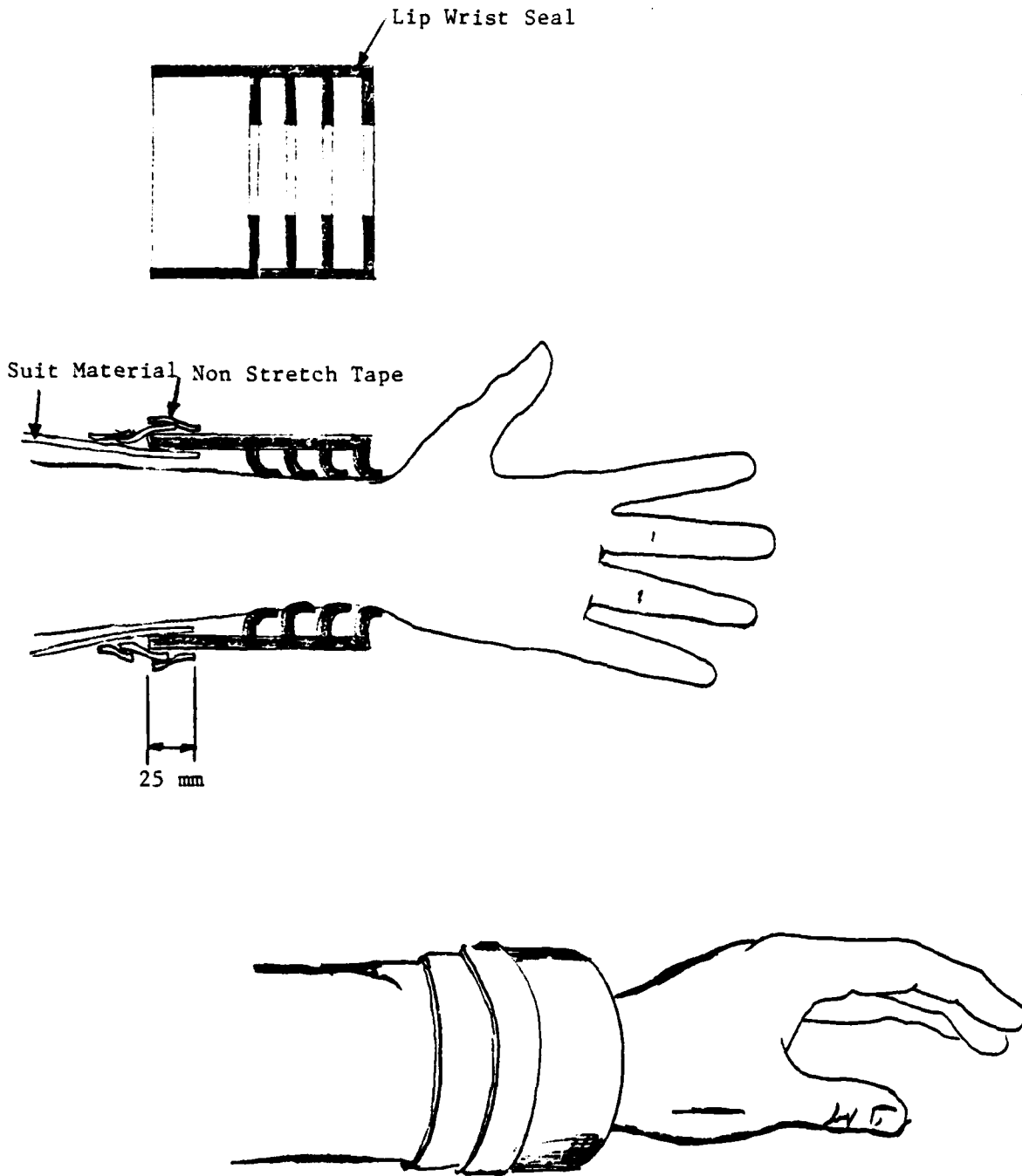

FIGURE 3. DETAILS FOR SUIT NO. 2

Closures

The optimal closure is shown in Figure 4 on Suit No. 2. The suit can be don/doffed by the diver without assistance, and ventilated before diving. A riveted tooth, gas sealing, zipper was used. The closure shown in Figure 2 required excessive contortions of the diver for don and doffing that is proved impractical for further consideration.

TEST PROCEDURES AND RESULTS

Leak Testing

The vacuum leak tester is shown in Figure 5. A measured vacuum is imposed on the apparatus at tap (1) at increasing suction until an air leak is sighted through the clear plastic housing (2) bubbling in the water (3). Steel can (4) simulates the diver's wrist, plastic pipe (5) provides internal structural support and tap (6) allows water to be added into the apparatus. A typical seal (7) is shown taped (8) to the clear plastic housing (2).

To test a seal, water is first added through the tap (6) until the level is slightly above the seal and can be easily seen, then tap (6) is closed. An increasing vacuum is then applied and measured at tap (1) until an air leak is sighted. The resulting data gives a comparative value for leak resistance.

Vacuum Leak Data

- (1) Viking Standard Wrist Seal Vacuum = 36 + inches water.
- (2) Inflatable Wrist Seal Vacuum = 3.5 inches water.*
- (3) Multiple Lip Wrist Seal Vacuum + 36 + inches water.

* Inflation pressure = 15 inches water

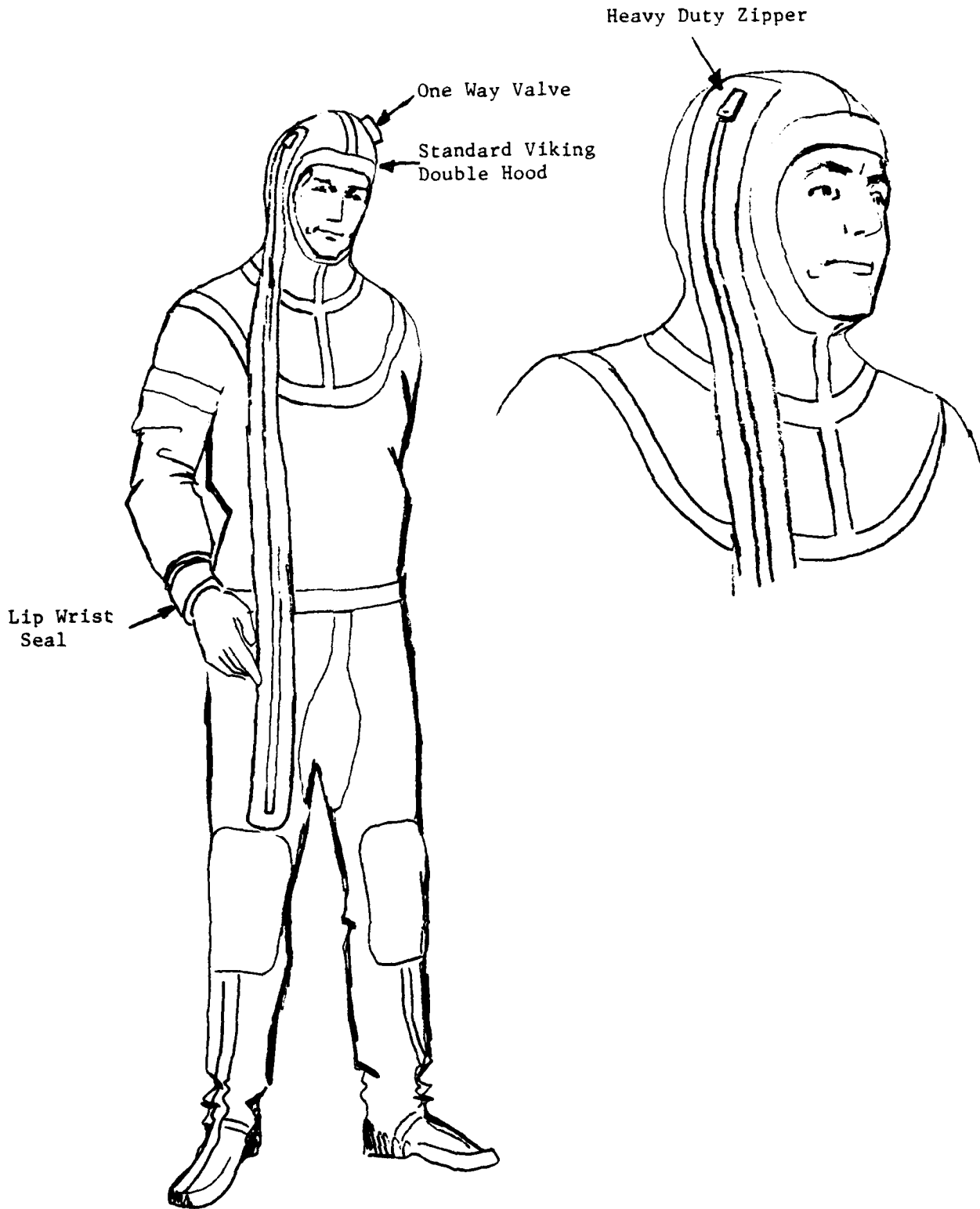

FIGURE 4. SUIT NO. 2

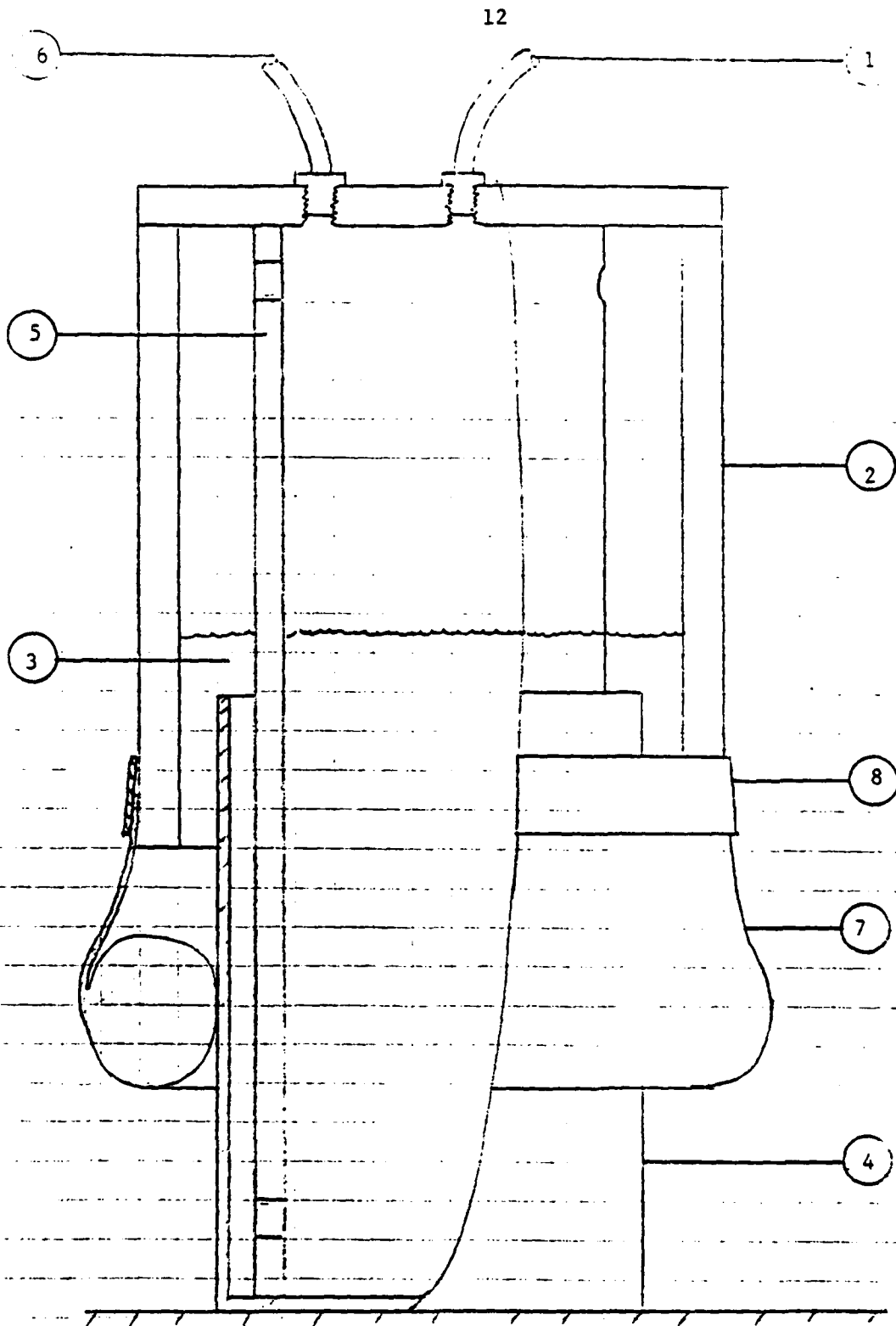

FIGURE 5. VACUUM LEAK TESTER

Stretch Testing

The neck seal stretch tester, shown in Figure 8, consists of two 1 x 1 x 3/16 inch steel angles (1) inserted 4 inches into the neck seal (2). The seal is stretched by twisting nut (3) on threaded shaft (4), thereby compressing a set of calibrated springs (5). A 1 x 3/16 inch steel bar (6) spreads and provides a pivot for the angle (6) which is 5.5 inch apart. The suit is put onto the apparatus to a point 10 in along each angle from each pivot point. For purposes of comparison the resulting data shows a relationship between spring force and spread travel which is charted in Figure 9.

The wrist seal stretch tester, shown in Figure 6, consists of a sized steel can (1), which simulates the divers wrist, attached to a steel shaft (2) that slides through an O-ring seal in plate (3). A plastic bag (4) is sealed and affixed to plate (3) with clamp (5) and the suit (6) is pulled over the apparatus until the seal end reaches the bottom of the can. A pressure tap (7) is located in the plate (3).

The wrist seal stretch is measured by inflating the bag with a measured pressure at the tap until the shaft is free to slide inside the bag. The pressure is measured for various sizes of steel cans; the resulting data in Figure 7 compares pressure with wrist size.

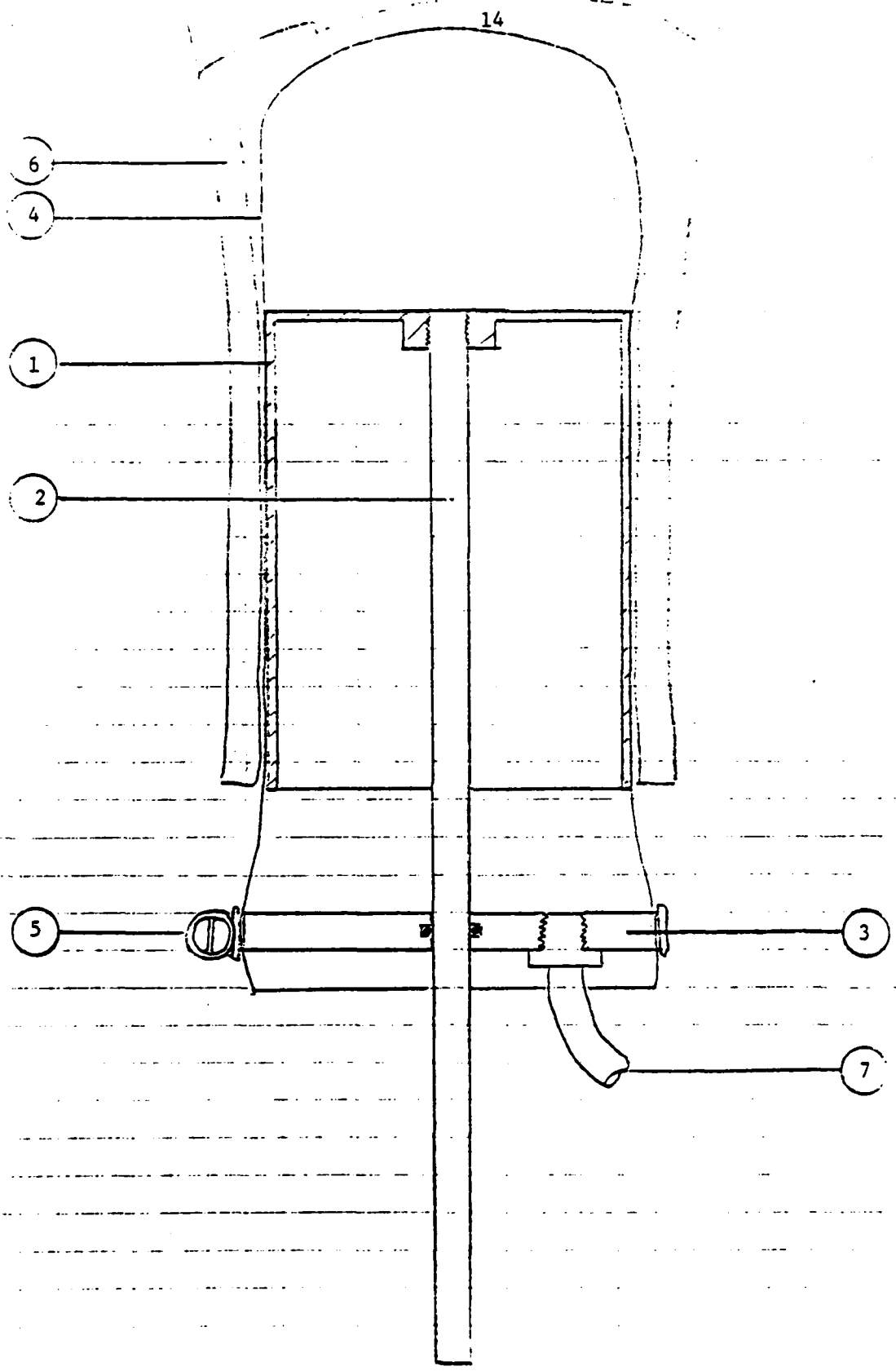

FIGURE 6. WRIST SEAL STRETCH TESTER

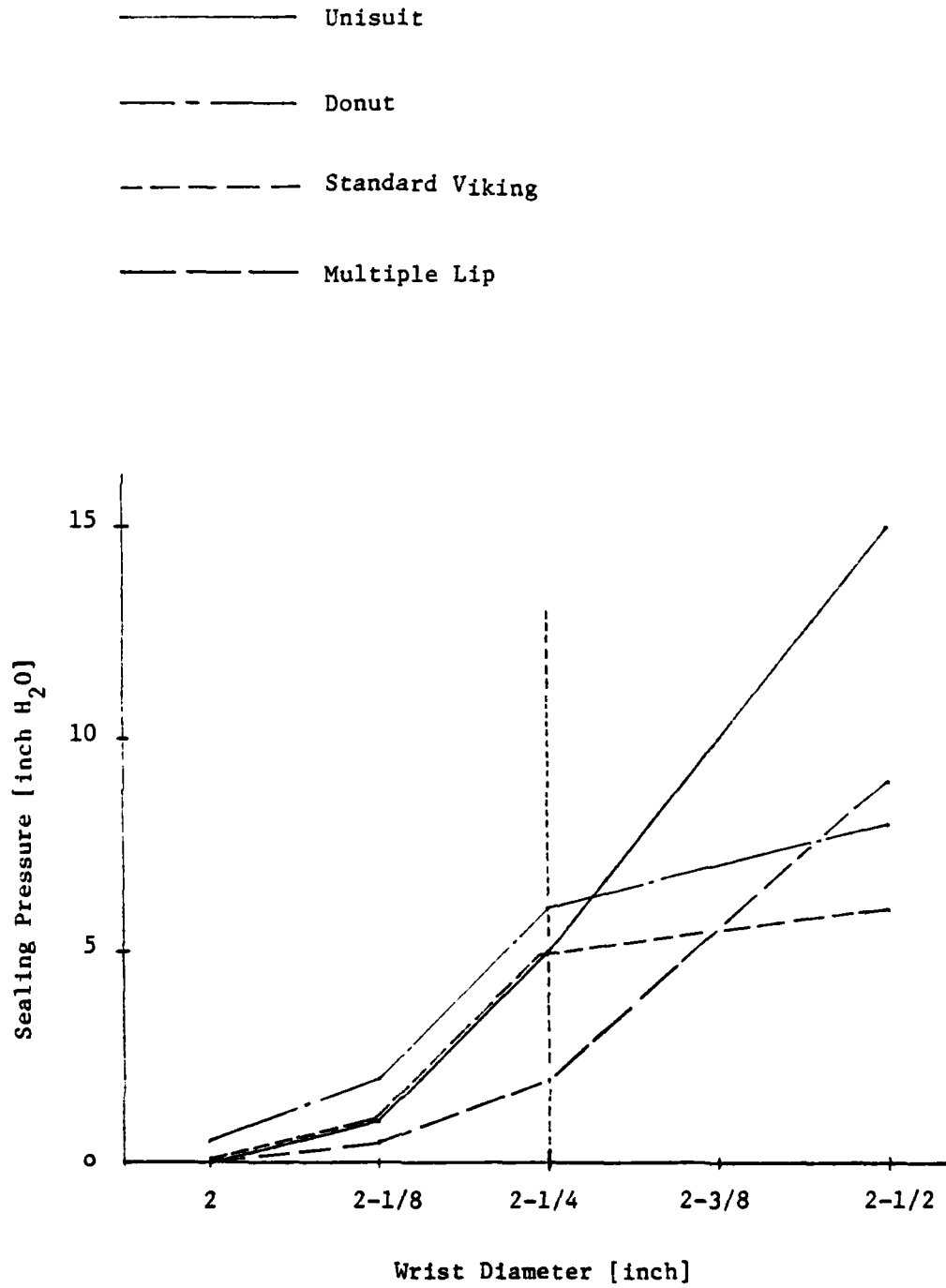

FIGURE 7. MEASURED WRIST SEAL PRESSURE

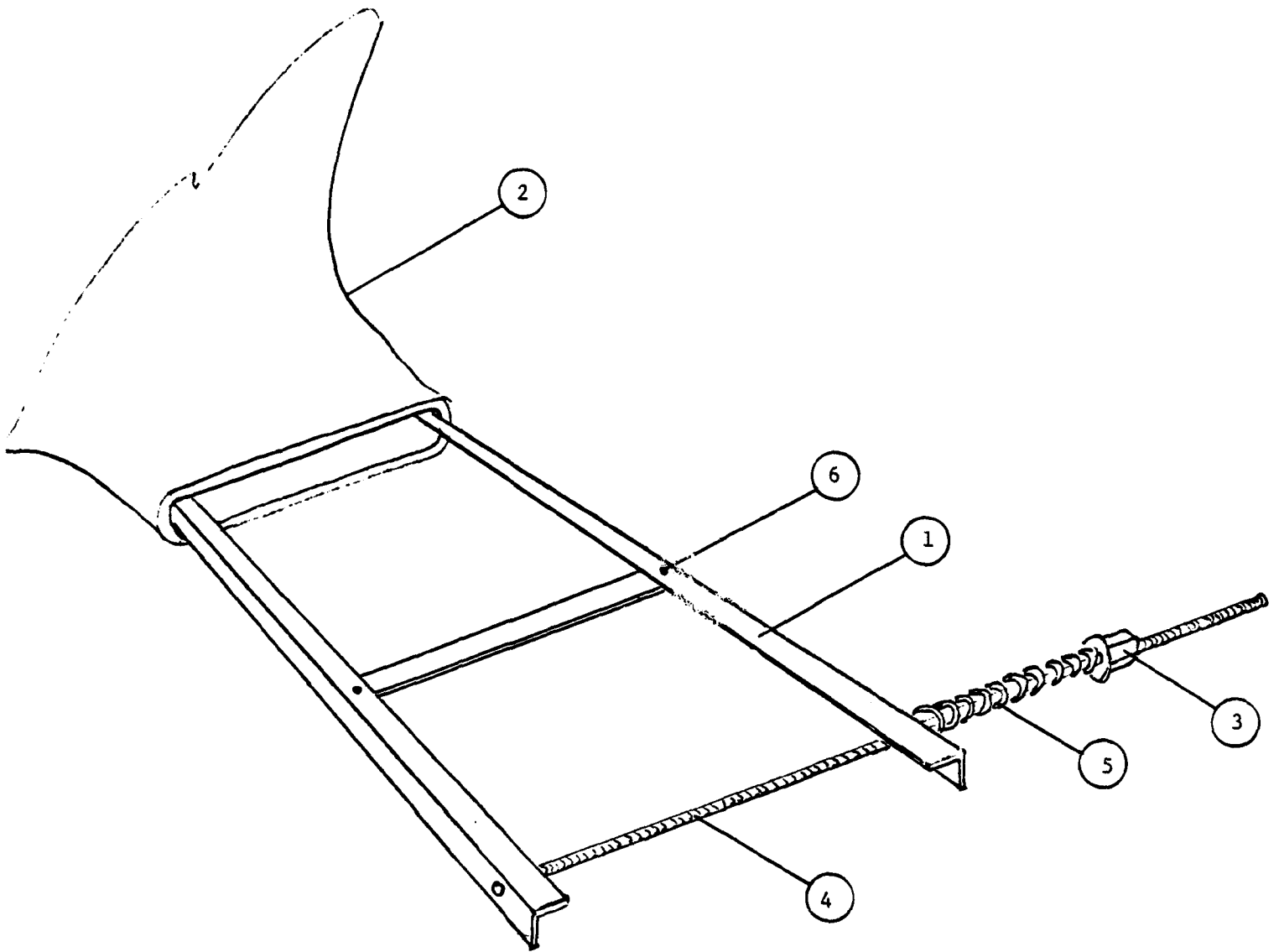

FIGURE 8. NECK SEAL STRETCH TESTER

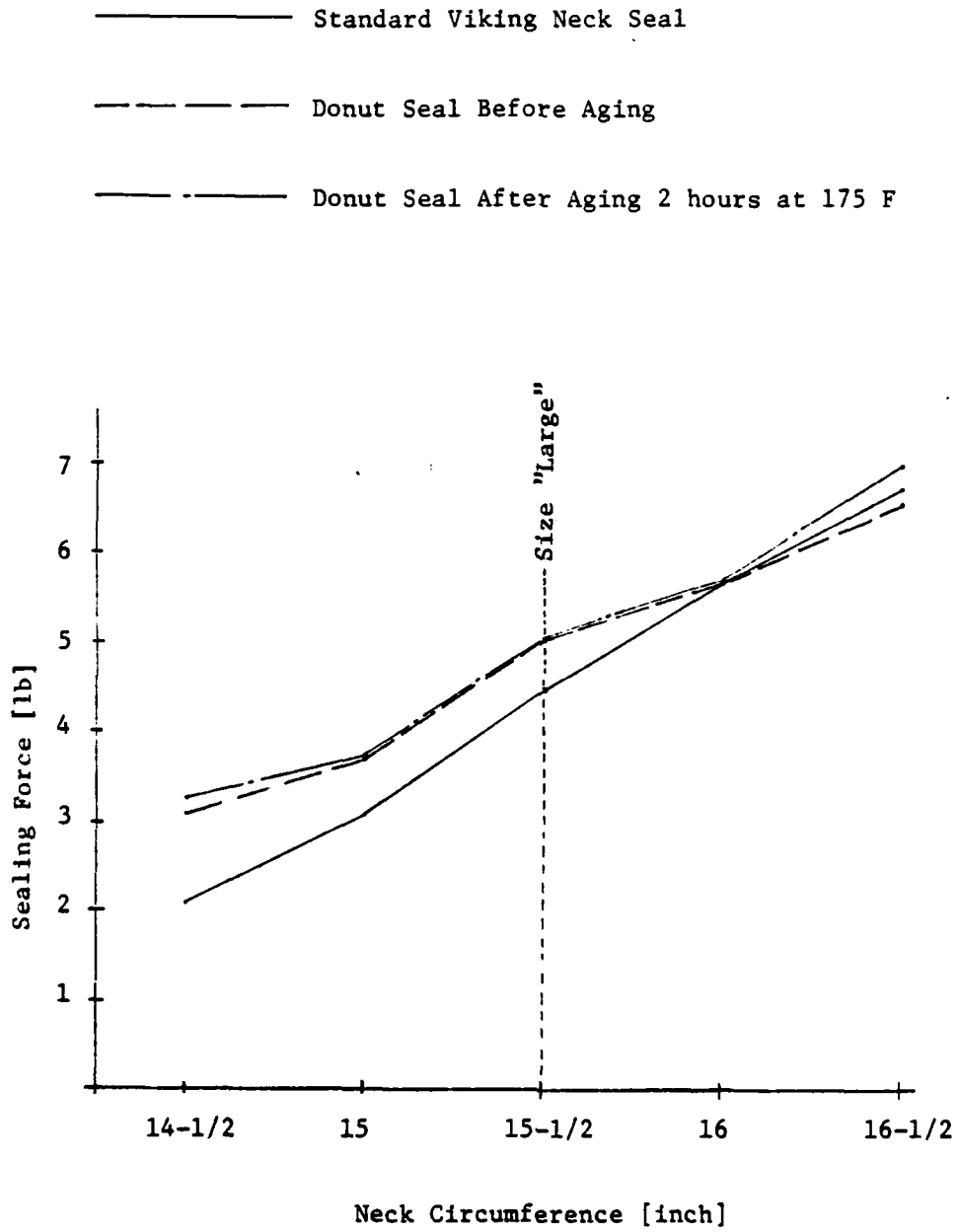

FIGURE 9. MEASURED NECK SEAL STRETCH

Underwater Suit Testing Results

Suit Nos. 1 and 2 were tested to 25 foot depths by swimming, rising buoyantly headfirst, then using buoyantly feet first. Suit No. 1 required a tender to don/doff and leaked underwater at the neck seal. Suit No. 1 leaked slightly at the wrist seals; also the "donut" type seals filled with water. In general the donut seals do not outperform commercially available seals.

Suit No. 2 experienced no significant leakage, could be don/doffed by the diver alone, and was comfortable at the wrist and head. The zipper did not cause irritation to the diver under his weight belt nor limit his movement. The zipper was easy to lubricate with beeswax and allowed the diver to ventilate and/or urinate topside.

Both divers wallowed underwater in sand, causing no noticeable problems in seal or zipper integrity.

