

1

OF



AD A

115206

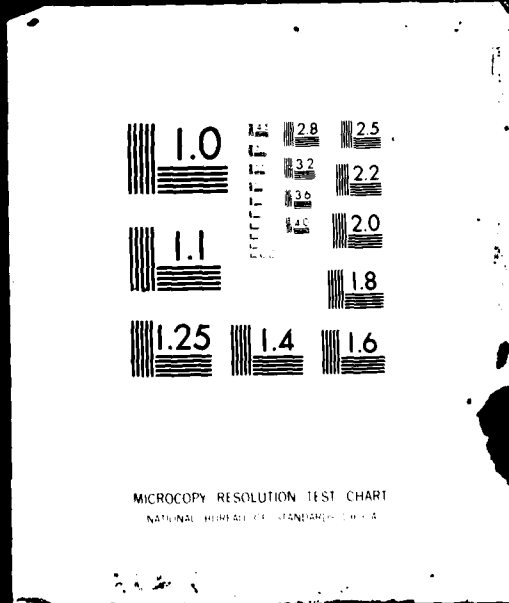

1

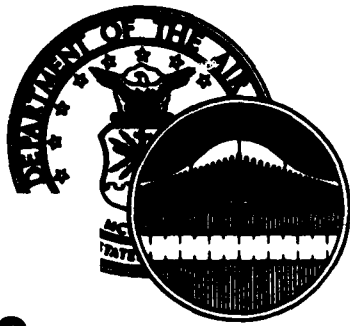

UNITED STATES AIR FORCE

AD A115206

OCCUPATIONAL SURVEY REPORT



INTEGRATED AVIONICS ATTACK CONTROL SYSTEMS
CAREER LADDER

AFSCs 326X6A/B/C

AFPT 90-326-428F

MARCH 1982

DTIC
ELECTE
JUN 07 1982

DTIC FILE COPY

OCCUPATIONAL ANALYSIS PROGRAM
USAF OCCUPATIONAL MEASUREMENT CENTER
AIR TRAINING COMMAND
RANDOLPH AFB, TEXAS 78150

E

APPROVED FOR PUBLIC RELEASE; DISTRIBUTION UNLIMITED

82 00 07 317

DISTRIBUTION

	<u>OSR</u>	<u>JOB INV</u>	<u>ANL EXT</u>	<u>TNG EXT</u>
AFHRL/LRT	1	1	1m	1m/1h
AFHRL/MODS	2	6	1m	1m
AFLMC/LGM	2	2		2
AFMEA/MEMD	1	1	1h	1
AFMPC/MPCHS	1	1		
AFMPC/MPCRPO	2			
ARMY OCCUPATIONAL SURVEY BRANCH	1	1		
CCAF/AYX	1	1		
DEFENSE TECHNICAL INFORMATION CENTER	1	1		
HQ AFISC/DAP	1	1		
HQ ATC/DPAE	3	3		3
HQ ATC/TTQ	2	1		1
HQ PACAF/DPAL	1	1		1
HQ PACAF/DPAT	3	3		3
HQ SAC/LGMQ (ATCLO)	1	1		1
HQ SAC/DPAT	3	3		3
HQ TAC/DPLATC	1	1		1
HQ TAC/DPAT	3	3		3
HQ USAF/MPPT	1	1		1
HQ USAFE/DPAT	3	3		3
HQ USAFE/DPATC	1	1		1
HQ USMC/OMU	1	1		
LMDC/AN	1			
LTTC	5	2	2h	9p*
NODAC	1	1		
388 TFW/MAT	2	2		2
3507 ACS/DPUI	1	1		
3785 FLDTG/TIFO	2	2		2

* per shred, total = 27

m = microfiche only
h = hard copy only
p = photo reduced

TABLE OF CONTENTS

	<u>PAGE NUMBER</u>
PREFACE -----	111
SUMMARY OF RESULTS -----	1v
INTRODUCTION -----	1
SURVEY METHODOLOGY -----	2
SPECIALTY JOBS (CAREER LADDER STRUCTURE)-----	8
ANALYSIS OF DAFSC GROUPS -----	22
COMPARISON OF SURVEY DATA TO AFR 39-1 SPECIALTY DESCRIPTIONS -----	30
TRAINING ANALYSIS-----	31
ANALYSIS OF JOB SATISFACTION -----	39
COMPARISON OF 32656X CONUS AND OVERSEAS GROUPS -----	42
ANALYSIS OF MAJOR COMMAND DIFFERENCES -----	46
ANALYSIS OF WRITE-IN COMMENTS -----	52
COMPARISON OF POMO PERSONNEL TO NON-POMO PERSONNEL-----	54
IMPLICATIONS -----	56
APPENDIX A, SPECIALTY JOB TYPE DESCRIPTIONS -----	57
APPENDIX B, REPRESENTATIVE TASKS PERFORMED BY SPECIALTY JOB GROUPS -----	58
APPENDIX C, TASKS NOT REFERENCED TO STSS -----	59



Accession For	
NTIS GRA&I	<input checked="" type="checkbox"/>
DTIC TAB	<input type="checkbox"/>
Unannounced	<input type="checkbox"/>
Justification	
By _____	
Distribution/ _____	
Availability Codes	
Dist	Avail and/or Special
A	

PREFACE

This report presents the results of a detailed Air Force occupational survey of the Integrated Avionics Attack Control Systems career ladder, AFS 326X6A/B/C. This study was requested by HQ ATC/TTQ and the 3400 TCHTW/TTGX at Lowry AFB CO. Authority for conducting occupational surveys is contained in AFR 35-2. Computer outputs from which this report was produced are available for use by operating and training officials.

The survey instrument used in the present project was developed by Mr J. Michael Bozardt, Inventory Development Specialist. Second Lieutenant Carlton F. Middleton analyzed the survey data and wrote the final report. This report has been reviewed and approved by Lieutenant Colonel Jimmy L. Mitchell, Chief, Airman Career Ladders Analysis Section, Occupational Analysis Branch, USAF Occupational Measurement Center, Randolph AFB, Texas 78150.

Copies of this report are distributed to air staff sections, major commands, and other interested training and management personnel. Additional copies are available upon request to the USAF Occupational Measurement Center, attention to the Chief, Occupational Analysis Branch (OMY), Randolph AFB, Texas 78150.

This report has been reviewed and is approved.

PAUL T. RINGENBACH, Col, USAF
Commander
USAF Occupational Measurement
Center

WALTER E. DRISKILL, Ph.D.
Chief, Occupational Analysis Branch
USAF Occupational Measurement
Center

SUMMARY OF RESULTS

1. Survey Coverage: Inventory booklets were administered to Integrated Avionics Attack Control Systems incumbents during 1980. The 554 personnel comprising the final survey sample accounted for 59 percent of the total career ladder and were representative across MAJCOMs and paygrades.
2. Specialty Jobs (Career Ladder Structure): Based on the similarity of tasks performed, 326X6 personnel grouped into four major clusters and several small independent job types. Three of the four clusters performed technical jobs that were consistent with their AFSC shredout. The fourth was comprised of supervisory and managerial personnel. The independent job types included instructors, debriefers, and quality control personnel. There was also one small group of personnel whose primary job performance included tasks that are officially the responsibility of the 326X7 and 326X8 AFSCs.
3. Career Ladder Progression: Three- and 5-skill level personnel in all shreds perform an almost exclusively technical job. The 7-skill level personnel perform both a technical and a supervisory and managerial job. Forty-three percent of all the 7-skill level respondents were identified in almost completely non-technical jobs. The rest of the 7-skill level personnel were interspersed in other jobs, performing both technical and non-technical tasks. The analysis of experience (TAFMS) groups showed a similar trend of progression from the more technical jobs to supervisory and managerial positions.
4. Analysis of Job Satisfaction: A look at job satisfaction showed A-shred personnel to have the highest overall satisfaction for first-enlistment incumbents. Personnel did not seem to find their job more interesting with progression in the career ladder, as is usually the case. Generally, 326X6 personnel reflected similar job satisfaction as other related AFSCs surveyed during 1980.
5. Analysis of AFR 39-1: The AFR 39-1 specialty descriptions were generally accurate for the common jobs performed across aircraft, excluding the aircraft specific tasks which differentiated the three 326X6 shreds. No major changes are recommended at this time.
6. Training Analysis: Lack of agreement among raters on task difficulty and training emphasis ratings limited the analysis of training. Examination of the 326X6A, 326X6B, and 326X6C Specialty Training Standards in light of occupational survey data revealed that the STSs seem to provide a comprehensive list of tasks, skills, and knowledges for each specialty shredout.
7. Implications: The jobs identified in this study support the present three shredout classification structure at the 3- and 5-skill levels. Review of specialty documents and training programs revealed no areas requiring change. One minor problem surfaced through write-in comments from personnel working on the B-1 test program; however, their situation should be resolved as the B-1 system becomes operational.

OCCUPATIONAL SURVEY REPORT
INTEGRATED AVIONICS ATTACK CONTROL SYSTEMS
(AFSC 326X6A/B/C)

INTRODUCTION

This is a report of an occupational survey of the Integrated Avionics Attack Control Systems career ladder (AFSC 326X6A/B/C) completed by the Occupational Analysis Branch, USAF Occupational Measurement Center, in February 1982. The primary purpose of this study is to evaluate the effectiveness of current training programs.

Background

Personnel in former AFS 326X2A (Integrated Avionics Systems, Inertial/Bomb Navigation, Fire/Weapons Control, Digital Computers, and Multi-sensor Displays) maintained aircraft attack control systems from July 1972 until April 1979. On 30 April 1979, restructuring of all Integrated Avionics Maintenance specialties went into effect. This restructuring resulted in separate specialties for flightline maintenance of attack control systems (AFS 326X6), instrument and flight control systems (AFS 326X7), and communications, navigation, and penetration aids systems (AFS 326X8). Additionally, each of these new specialties was further divided through the 5-skill level into three shreds specifying the aircraft maintained:

- A shred - F/FB-111
- B shred - F-15
- C shred - F-16

Seven-skill level incumbents have no shred and are assigned to units having any of the aircraft within their specialty. Also, there is a common 9-skill level for all 326XX career ladders.

As described by AFR 39-1, the basic responsibilities of 326X6 personnel include identifying and isolating malfunctions of integrated avionic attack control systems; removing, installing, aligning, harmonizing, boresighting, and conducting checkouts of integrated avionic attack control systems; and maintaining inspection and maintenance records. Equipment maintained by these personnel includes television and cathode-ray tube displays, Doppler radar systems, electro-mechanical and electro-optical sighting systems, bomb navigation and fire and weapons control systems, and inertial navigation systems.

Completion of a basic integrated avionics attack control systems course as well as a Field Training Detachment (FTD) course is mandatory for AFSC assignment. The basic course for all 32636 personnel (course G3AQR32636-001), conducted at Lowry AFB CO, lasts approximately 30 academic days. After successful completion of this course, individuals attend one of five FTD courses offered, depending on which 326X6 shred they are entering. A-shred personnel go to one of three FTD courses, with each course being specifically geared to a certain model or models of the General Dynamics F/FB-111 aircraft. All B-shred (F-15) airmen attend one FTD course and all C-shred (F-16) airmen attend one FTD course.

APPROVED FOR PUBLIC RELEASE; DISTRIBUTION UNLIMITED

SURVEY METHODOLOGY

Inventory Development

A single job inventory (AFPT 90-326-428F) served to collect data for the 326X6, 326X7, and 326X8 career ladders. As a starting point for the 326X6 section of the inventory, the inventory developer reviewed the previous 1976 inventory of AFS 326X2A for currency. A thorough review of pertinent 326X6 career ladder publications and directives identified additional tasks for inclusion. From this review process, the inventory developer put together a new tentative task list for the 326X6 specialty. He then took this tentative task list to the technical school and several operational units for validation by experienced senior personnel. Nine 326X6 subject matter specialists in seven operational units assisted the developer. Additionally, personnel in the 326X7 and 326X8 career ladders reviewed their respective specialty tasks in the job inventory. The final inventory consisted of 852 tasks under 25 duty headings covering 326X6, 326X7, and 326X8 career ladders. The task inventory also included an extensive background section with questions regarding job title, job satisfaction, organizational level, and other similar types of information.

Survey Sample

A sample of eligible members (excluding those in PCS status, hospitalized, or on the job less than six weeks) of the 326X6 population was identified to complete the USAF job inventory. Overall, the sample consisted of responses from 554 of the 933 total assigned, or 59 percent of the total 326X6 population. As can be seen in Tables 1 through 6, this sample was representative of the career ladder at the time. Table 1 contrasts the sample with the major command distribution of the personnel assigned to the 326X6 career field in June 1980. Tables 2, 3, and 4 provide the major command distribution for each shred and illustrate the representativeness of the sample. The percentage distribution by paygrade for the 326X6 sample displayed in Table 5 reflects that over 60 percent of both assigned members and the sample are E-4 or below. In line with this, Table 6 displays the survey sample in terms of TAFMS groups and shows that over half of all the people in the 326X6 specialty are in their first enlistment.

Task Factor Administration

In addition to completing a job inventory booklet, selected senior personnel assigned to F-15, F-16, F-111 units completed a second booklet for either training emphasis or task difficulty. From these booklets, average task difficulty and average training emphasis ratings are computed for each task in the job inventory. These ratings normally help in analyzing the training programs in the career ladders because they provide an indication of what the senior personnel in the ladder feel are the most difficult tasks and the tasks where training is most crucial. Unfortunately, the 326X6 training emphasis and task difficulty ratings did not meet the minimum required reliability and could not be used in analysis.

TABLE 1
COMMAND REPRESENTATION OF SURVEY SAMPLE
(TOTAL 326X6A/B/C SAMPLE)

<u>COMMAND</u>	<u>PERCENT OF ASSIGNED*</u>	<u>PERCENT OF SAMPLE</u>
TAC	56	54
USAFE	17	20
SAC	8	9
ATC	5	8
PACAF	6	4
OTHER	<u>8</u>	<u>5</u>
TOTAL	100	100

TOTAL ASSIGNED* - 933

TOTAL ELIGIBLE FOR SURVEY** - 800

TOTAL SAMPLE - 554

PERCENT OF ELIGIBLE IN SAMPLE - 69%

* ASSIGNED STRENGTH AS OF JUNE 1980

** EXCLUDES THOSE IN PCS STATUS, STUDENTS, HOSPITALIZED
PERSONNEL, AND PERSONNEL WITH LESS THAN SIX WEEKS
ON THE JOB

TABLE 2

COMMAND REPRESENTATION OF SURVEY SAMPLE
326X6A

<u>COMMAND</u>	<u>PERCENT OF ASSIGNED*</u>	<u>PERCENT OF SAMPLE</u>
TAC	49	48
USAFE	23	24
SAC	16	19
ATC	3	5
OTHER	<u>9</u>	<u>4</u>
TOTAL	100	100

TOTAL A-SHRED PERSONNEL ASSIGNED* - 391

TOTAL A-SHRED PERSONNEL ELIGIBLE FOR SURVEY** - 320

NUMBER OF RESPONDENTS INDICATING AN A-SHRED DAFSC SUFFIX - 221

* ASSIGNED STRENGTH AS OF JUNE 1980

** EXCLUDES THOSE IN PCS STATUS, STUDENTS, HOSPITALIZED
PERSONNEL, AND PERSONNEL WITH LESS THAN SIX WEEKS
ON THE JOB

TABLE 3
COMMAND REPRESENTATION OF SURVEY SAMPLE
326X6B

<u>COMMAND</u>	<u>PERCENT OF ASSIGNED*</u>	<u>PERCENT OF SAMPLE</u>
TAC	58	67
USAFE	17	14
PACAF	16	13
ATC	2	0
OTHER	<u>7</u>	<u>6</u>
TOTAL	100	100

TOTAL B-SHRED PERSONNEL ASSIGNED* - 275

TOTAL B-SHRED PERSONNEL ELIGIBLE FOR SURVEY** - 242

NUMBER OF RESPONDENTS INDICATING A B-SHRED DAFSC SUFFIX - 101

* ASSIGNED STRENGTH AS OF JUNE 1980

** EXCLUDES THOSE IN PCS STATUS, STUDENTS, HOSPITALIZED PERSONNEL, AND PERSONNEL WITH LESS THAN SIX WEEKS ON THE JOB

TABLE 4

COMMAND REPRESENTATION OF SURVEY SAMPLE
326X6C

<u>COMMAND</u>	<u>PERCENT OF ASSIGNED*</u>	<u>PERCENT OF SAMPLE</u>
TAC	88	86
ATC	2	4
SAC	1	0
PACAF	1	1
OTHER	<u>8</u>	<u>9</u>
TOTAL	100	100

TOTAL C-SHRED PERSONNEL ASSIGNED* - 132

TOTAL C-SHRED PERSONNEL ELIGIBLE FOR SURVEY** - 97

NUMBER OF RESPONDENTS INDICATING A C-SHRED DAFSC SUFFIX - 81

* ASSIGNED STRENGTH AS OF JUNE 1980

** EXCLUDES THOSE IN PCS STATUS, STUDENTS, HOSPITALIZED
PERSONNEL, AND PERSONNEL WITH LESS THAN SIX WEEKS
ON THE JOB

TABLE 5
PAYGRADE DISTRIBUTION OF SURVEY SAMPLE
(TOTAL 326X6 A/B/C SAMPLE)

<u>GRADE</u>	<u>PERCENT OF ASSIGNED</u>	<u>PERCENT OF SAMPLE</u>
AIRMAN	38	29
E-4	29	33
E-5	20	23
E-6	8	10
E-7	<u>5</u>	<u>5</u>
TOTAL	100	100

TABLE 6
TAFMS DISTRIBUTION OF SURVEY SAMPLE
(TOTAL 326X6A/B/C SAMPLE)

<u>TAFMS (MONTHS)</u>	<u>PERCENT OF SAMPLE</u>
1-48	55
49-96	17
97-144	11
145+	17

SPECIALTY JOBS (Career Ladder Structure)

One of the most important functions of the USAF occupational analysis program is to identify the distinct jobs performed within a specialty and how these jobs relate to one another. The diversity of jobs is important to the USAF Personnel Classification System. If the jobs are too diverse or specialized, AFMPC may need to split the specialty into separate career ladders (or shredouts). If related specialties are similar enough (in terms of tasks, required skills, or related knowledges), AFMPC may merge them together to minimize assignment problems (such as CONUS/overseas imbalance), provide better career progression, or to minimize recruiting problems.

The diversity of jobs within a specialty (or related group of specialties) is also very important information for the training community. Common resident training is most efficient when specialty jobs are similar (in terms of required skills and knowledges). If jobs are too diverse, technical school training may not be cost-effective and new personnel must learn through on-the-job training (OJT).

Job information is also used to analyze career progression patterns and specialty documents (AFR 39-1 Specialty Description, Specialty Training Standard, etc.) to identify needed changes. Job data are also used to review training programs, identify morale (job satisfaction) problems, to identify trends, and to highlight issues needing management attention.

Within the Attack Control Systems specialty, ten independent job types and four major job clusters (of related jobs) were identified. These are shown in Figure 1 and listed below:

- I. F/FB-111 TECHNICAL MAINTENANCE PERSONNEL (GRP099, N=200)
 - a. F-111D Maintenance Personnel (GRP149, N=44)
 - b. F/FB-111A/E/F Maintenance Personnel (GRP125, N=154)
- II. F/FB-111 FIELD TRAINING DETACHMENT (FTD) INSTRUCTORS (GRP103, N=8)
- III. F-111 TECHNICIAN-SUPERVISORS (GRP100, N=6)
- IV. F-15 TECHNICAL MAINTENANCE PERSONNEL (GRP079, N=114)
- V. F-15 FTD INSTRUCTORS (GRP091, N=7)
- VI. F-16 TECHNICAL MAINTENANCE PERSONNEL (GRP097, N=70)
 - a. F-16 Senior Technical Workers (GRP146, N=20)
 - b. F-16 Junior Technical Workers (GRP147, N=36)
- VIII. F-16 FTD INSTRUCTORS (GRP073, N=9)
- VII. INTEGRATED AVIONICS ATTACK, INSTRUMENT, AND FLIGHT CONTROL SYSTEMS MAINTENANCE PERSONNEL (GRP048, N=12)

FIGURE 1
326X6X CAREER LADDER STRUCTURE

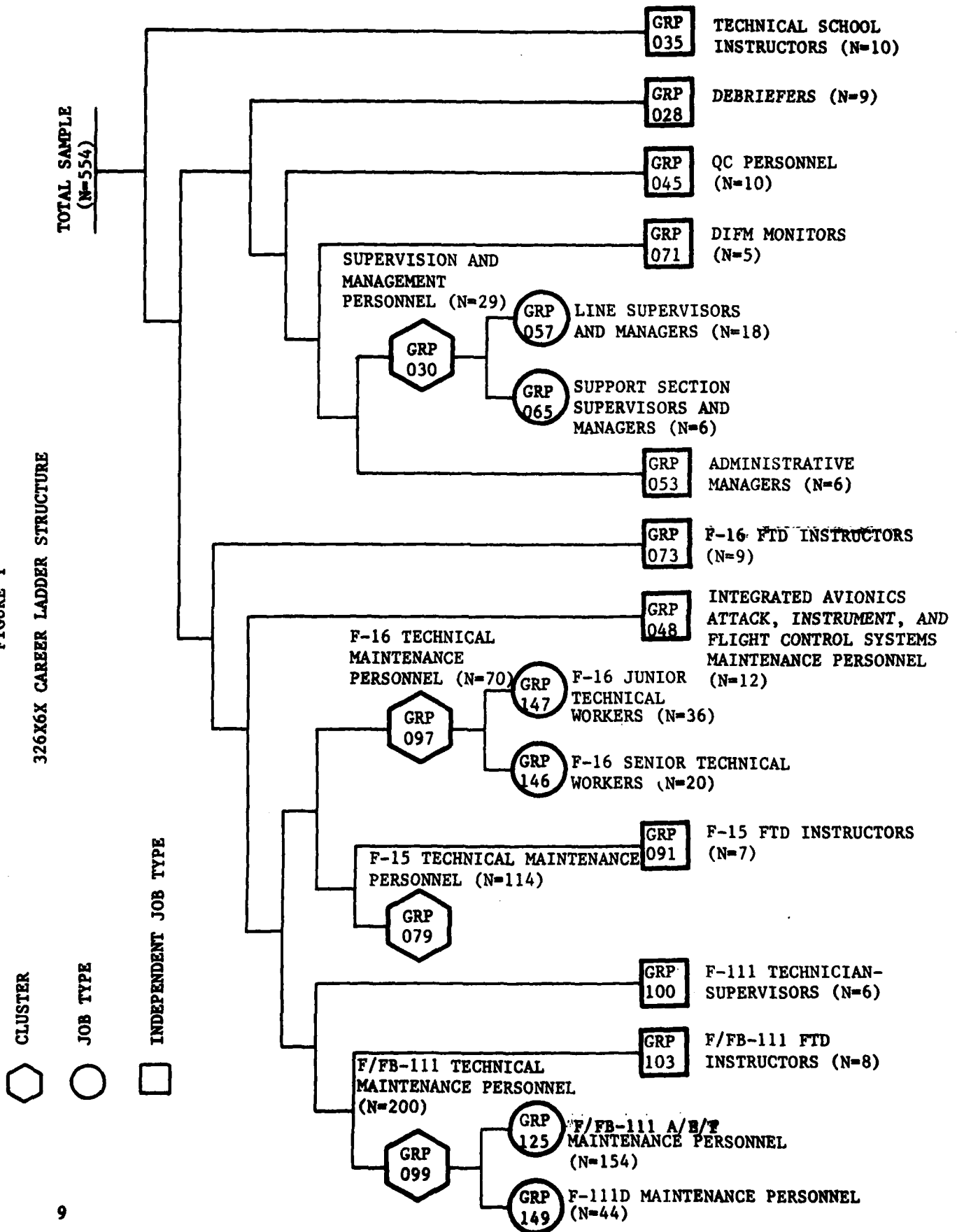

- IX. ADMINISTRATIVE MANAGERS (GRP053, N=6)
- X. SUPERVISION AND MANAGEMENT PERSONNEL (GRP030, N=29)
 - a. Support Section Supervisors and Managers (GRP065, N=6)
 - b. Line Supervisors and Managers (GRP057, N=18)
- XI. DUE-IN-FOR-MAINTENANCE (DIFM) MONITORS (GRP071, N=5)
- XII. QUALITY CONTROL (QC) PERSONNEL (GRP045, N=10)
- XIII. DEBRIEFERS (GRP028, N=9)
- XIV. TECHNICAL SCHOOL INSTRUCTORS (GRP035, N=10)

The clusters and independent job types listed above comprised 89 percent of the total sample. The remaining eleven percent of the sample involved personnel with unique, unrelated jobs (one-of-a-kind positions).

Job Group Descriptions

A brief description of each of the four clusters and 10 independent job types is given below. Job types which combined to form each cluster are discussed in detail in Appendix A. More representative tasks for each group and subgroup identified are listed in Appendix B.

I. F/FB-111 TECHNICAL MAINTENANCE PERSONNEL (GRP099). The 200 personnel in this cluster perform the major flightline maintenance on the F/FB-111 integrated avionics attack control systems. Eighty-six percent of their job time is spent maintaining terrain following radar (TFR), attack radar systems (ARS), inertial navigation systems (INS), and low altitude radar altimeter (LARA) systems. Smaller percentages also maintain the digital computer complex (DCC), optical display sight systems (ODSS), lead computing optical sight systems (LCOSS), and control and display sets (CDS). Common tasks performed by these individuals include:

- Remove or install TFR system line replaceable units (LRUs)
- Isolate malfunctions to TFR computers
- Isolate malfunctions to TFR antenna-receivers
- Remove or install ARS system LRUs
- Adjust TFR antenna-receivers
- Perform operational checks of LARA systems
- Isolate malfunctions to TFR synchronizer-transmitters
- Remove or install LARA system LRUs

Members of this cluster perform an average of 120 tasks. Forty-eight percent report TAC as their major command, with USAFE and SAC accounting for another 29 and 19 percent, respectively. Eighty-one percent report a 5-skill level, with an average time in service for the group being 51 months. Only 27 percent of these incumbents report supervising other personnel. Common test equipment used by these workers include electrical connector aircraft wiring repair tool kits (DCM-216), pressurization test sets, and radar signal simulator test sets.

This cluster contains two job types: the first is almost exclusively composed of personnel maintaining F-111D model aircraft at Cannon AFB NM. The second job type consists of individuals from a number of different bases who maintain A, E, or F model aircraft. These job types are distinct because of variations in tasks involved in the maintenance of the different aircraft models (more detail is given in Appendix A).

II. F/FB-111 FIELD TRAINING DETACHMENT (FTD) INSTRUCTORS (GRP103). Seven of these eight members conduct training for 326X6 personnel at the F/FB-111 FTD courses. The eighth member is an FTD instructor supervisor. Four members are assigned to the 513th FTD at Mt Home AFB ID; three are assigned to the 210th FTD at Plattsburgh AFB NY; and one member is assigned to the 3785th Field Training unit at Plattsburgh AFB. Typically, the job of these instructors consists of providing flightline maintenance training on the integrated avionics attack control systems of F/FB-111 aircraft to trainees. Common tasks performed by these personnel are:

- Conduct FTD training
- Demonstrate operation of equipment
- Administer or score tests
- Evaluate progress of students
- Operate terrain following radar (TFR) test sets
- Isolate malfunctions to ARS indicator-recorders
- Adjust TFR antenna receivers
- Isolate malfunctions to ARS electrical synchronizers
- Isolate malfunctions to TFR indicators
- Isolate malfunctions to ARS modulator-receiver-transmitters

Twenty-two percent of the job time is spent in the area of training. Sixty-two percent of their time is spent in the technical areas of maintenance; however, much of this time is spent demonstrating maintenance techniques to students.

III. F-111 TECHNICIAN-SUPERVISORS (GRP100). The responsibilities of these six members are divided between technical flightline maintenance and flightline supervision. Twenty-nine percent of their relative job time is spent in the areas of supervision and training. Technical maintenance duties comprise an additional 69 percent of their job time. Generally, these individuals maintain the attack control systems as well as supervise other personnel who maintain the systems. Emphasis seems to be more on the LARA and CDS systems rather than on TFR and ARS systems, although all systems are maintained. Members of this group report performing an average of 208 tasks. Common tasks include:

- Analyze causes of operational discrepancies
- Direct maintenance or checkout of integrated avionic systems
- Perform operational checks of avionics status panels
- Supervise AFSC 32636A personnel
- Indoctrinate newly assigned personnel

All members of the group are either 5- or 7-skill level personnel, with 83 percent supervising 32636A personnel.

Common test equipment used by these individuals includes electrical connector aircraft wiring repair tool kits (DCM-216), pressurization test sets, and subsystem tie-in test sets. Foreign-object-damage (FOD) inspections are also a major part of the job, with 83 percent performing these inspections.

IV. F-15 TECHNICAL MAINTENANCE PERSONNEL (GRP079). The 114 members of this group perform the technical flightline maintenance of the integrated avionics attack control systems on F-15 aircraft. Eighty-four percent of their job time is spent maintaining APG-63 radar sets, central computers, vertical situation display (VSD) systems, multiple indicator control panel (MICP) systems, and heads up display (HUD) systems. On the average, members report performing 107 tasks. Common tasks include:

- Remove or install APG-63 radar set LRUs
- Perform Built-in-Tests (BIT) on VSD or MICP systems
- Operate APG-63 radar sets for integration checks
- Remove or install VSD or MICP LRUs
- Remove or install central computers
- Interpret BIT results on APG-63 radar sets
- Perform BIT on APG-63 radar sets
- Interpret BIT results on VSD or MICP systems
- Remove or install HUD system LRUs
- Isolate malfunctions to HUD processors or electronic units

Seventy-nine percent are 5-skill level incumbents. While most of these respondents hold a B shredout, seven individuals hold a DAFSC suffix other than the F-15 B suffix. Seventy percent also indicate being under POMO.

Some of the common equipment used by personnel includes electrical connector aircraft wiring repair tool kits (DCM-216) and radar signal simulator test sets. Sixty-seven percent also perform foreign object damage (FOD) inspections. Sixty-two percent are in TAC, with an additional 18 percent in USAFE, and 14 percent in PACAF.

V. F-15 FTD INSTRUCTORS (GRP091). Six of these seven members are FTD instructors. The seventh member is a Consolidated Aircraft Maintenance Training (CAMT) instructor at the 405th Headquarters, Luke AFB AZ. These instructors provide training for incoming F-15 maintenance personnel at the AFSC-awarding FTD courses. On the average, members of this group spend 29 percent of their time in the area of training. An additional 51 percent of their time is spent in technical maintenance, including demonstrations. The average number of tasks performed by these instructors is 82. Common tasks include:

- Conduct FTD training
- Demonstrate how to locate technical information
- Conduct formal classroom instruction
- Evaluate progress of students
- Demonstrate operation of equipment
- Convert computer language from octal to binary
- Interpret Built-in-Test (BIT) results on APG-63 radar sets

- Interpret BIT results on VSD or MICP systems
- Perform BIT on APG-63 radar sets
- Perform BIT on central computers
- Perform BIT on HUD systems

All members of this group have a 7-skill level DAFSC. Forty-three percent supervise other personnel.

VI. F-16 TECHNICAL MAINTENANCE PERSONNEL (GRP097). The 70 members of this group perform the technical flightline maintenance on the F-16 integrated avionics attack control systems. These systems include radar electro-optical (REO) systems, fire control radar (FCR) systems, fire control computers (FCC), HUD systems, and INS systems. Sixty of the incumbents indicate a C-shred DAFSC suffix. The average number of tasks performed is 98. Common tasks are:

- Isolate malfunctions to REO indicator units
- Remove or install REO system LRUs
- Isolate malfunctions to FCC
- Remove or install FCC system LRUs
- Isolate malfunctions to FCR system LRUs
- Perform FCC integration checks
- Interpret BIT results on REO systems
- Interpret BIT results on FCR systems
- Perform operational checks of REO display systems

Sixty-seven percent of the members are in their first enlistment. In addition, 60 percent have a 5-skill level. No personnel are stationed overseas; 91 percent are in TAC. Twenty-seven percent have converted from a previous 301XX AFSC, and nine percent converted from a 328XX AFSC.

Pressurization test sets are the only item of equipment used by over 50 percent of these workers. As an additional duty, 54 percent of the group also perform FOD inspections. Aircraft acceptance inspections are performed to a high degree as well.

VII. F-16 FTD INSTRUCTORS (GRP073). Eight of these nine members are concerned with training personnel on the F-16 aircraft. The ninth member is an F/FB-111 FTD instructor assigned to Mt Home AFB. All but two of the nine members are assigned to an FTD organization, and all but one list "instructor" as the title of their present job. Members of this group spend 28 percent of their job time in the area of training and perform an average of 63 tasks. Common tasks are:

- Conduct FTD training
- Evaluate progress of students
- Develop course curricula
- Perform BIT on REO systems
- Perform operational checks of REO display systems
- Perform BIT on FCR systems
- Perform REO system integration checks
- Perform FCR integration checks

VIII. INTEGRATED AVIONICS ATTACK, INSTRUMENT, AND FLIGHT CONTROL SYSTEMS MAINTENANCE PERSONNEL (GRP048). The 12 members of this group have a unique job in that they perform many tasks which are normally performed by Integrated Avionics Instrument and Flight Control Systems Maintenance (AFS 326X7) personnel. Thirty-six percent of their relative job time is spent maintaining instrument and flight control systems, and only 21 percent is spent maintaining attack control systems. An additional seven percent of their job time is spent maintaining Communications, Navigation, and Penetration-Aids systems (which are normally handled by AFS 326X8 personnel). These members perform an average of 360 tasks, substantially more than any other job group. Common tasks include:

- Remove or install automatic flight control system LRUs
- Remove or install Air Data Computer (ADC) or Central Air Data Computer (CADC) system LRUs
- Remove or install pitot-static probes and tubing
- Perform leak checks of pitot-static systems
- Perform operational checks of ADC or CADC systems
- Remove or install Attitude Directional Indicators (ADI)
- Isolate malfunctions to ADIs
- Isolate malfunctions to Horizontal Situation Indicators (HSI)
- Remove or install Angle-of-Attack (AOA) indexers, indicators, or transmitters

Fifty-eight percent are in TAC, 25 percent are in AFSC, and 17 percent are in USAFE. Members maintain a variety of F-15, F-16, and F-111 aircraft models, with the EF-111A and FB-111 aircraft not being maintained.

This job group is the only group identified performing maintenance on more than one aircraft system and doing maintenance on other avionics (326X7 and 326X8 tasks). For the four individuals in Air Force Systems Command, performing such "generalist" avionics maintenance is not surprising, since AFSC is a research environment. Apparently, there are at least a few individuals in TAC and USAFE who are also being utilized as "generalists" to meet local requirements.

IX. ADMINISTRATIVE MANAGERS (GRP053). Unlike members in the previously discussed groups, these six members spend only two percent of their time performing technical flightline maintenance. Their job consists of keeping records, performing managerial administrative work, and supervising personnel. Thirty-three percent of their time is spent in the administrative area of maintaining forms, records, and reports. Various supervisory and managerial duties take up another 60 percent of their time. On the average, members perform only 34 tasks. Common tasks include:

- Write correspondence
- Interpret policies, directives, or procedures for subordinates
- Design local worksheets or forms
- Determine work priorities
- Type information on forms

Job titles reported by these incumbents include NCOIC Debriefing, avionics analyst, and squadron mobility NCO. Fifty percent of these individuals are located overseas and 50 percent are in POMO organizations. Three of the six members hold a 7-skill level. Sixty-seven percent supervise others, with the average time in service for the group being 125 months.

X. SUPERVISION AND MANAGEMENT PERSONNEL (GRP030). These 29 personnel spend most of their job time performing supervision and management duties, with only 10 percent of their job time spent in technical areas. On the average, these incumbents perform 78 tasks. Common tasks include:

- Coordinate work
- Prepare duty rosters
- Counsel personnel
- Prepare APRs
- Plan work assignments
- Assign personnel to duty positions

These respondents are fairly senior (average grade is E-6), with the average time in service being 173 months. Most have a 7-skill level and do not hold a DAFSC prefix or suffix.

XI. DUE-IN-FOR-MAINTENANCE (DIFM) MONITORS (GRP071). Three of these five members list their job title as "DIFM monitor". They primarily maintain records and forms for specific equipment, spending 46 percent of their job time on this function. Members perform an average of only 24 tasks. Common tasks include:

- Determine work priorities
- Make entries on Repairable Item Processing Tag (AFTO Form 350)
- Make entries on Supply Control Log (AF Form 2413)
- Make entries on Serviceable Tag-Materiel (DD Form 1574)
- Review Serviceable Tag-Materiel (DD Form 1574)
- Conduct follow-up action on supply or work requests
- Make entries on Issue/Turn-In Request (AF Form 2005)

All members hold a 5-skill level DAFSC and 80 percent are in their first enlistment. All are in TAC and work under the POMO concept. Forty percent are female and 40 percent supervise at least one other person.

XII. QUALITY CONTROL (QC) PERSONNEL (GRP045). All 10 members of this group indicate a job title of "Quality Control Inspector". Forty-five percent of their job time is spent inspecting and evaluating, with only nine percent spent in the technical maintenance areas. Incumbents perform an average of only 27 tasks. Common tasks include:

- Make entries on routing and review of Quality Control Reports (AF Form 2419)
- Perform safety inspections
- Make entries on Quality Control Inspection Summary (AF Form 2420)

Inspect facilities or work areas for condition or appearance
Evaluate equipment modifications or technical order (TO) changes
Investigate accidents or incidents

Fifty percent are assigned overseas. The average time in service for these 7-skill level DAFSC personnel is 186 months. None of them supervise other personnel. Half of the members of this group are in TAC, and four members converted from a 321XX career ladder.

XIII. DEBRIEFERS (GRP028). Seventy-eight percent of these nine members list their job title as "debriefers." This job consists of debriefing aircrews on the avionics systems of the aircraft and finding out from the aircrew what systems had problems in previous flights. Many times, individuals in this position also maintain a file of the aircraft history. Sixty-one percent of the job time is spent in the area of maintaining forms, records, and reports. Incumbents perform an average of only nine tasks. Common tasks include:

- Make entries on Maintenance Discrepancy and Work Document (AFTO Form 781A)
- Make entries on Maintenance Data Collection Record (AFTO Form 349)
- Develop records of maintenance and disposition files

All members are in TAC and work under POMO. Forty-four percent are female, and 67 percent are in their first enlistment. All members hold either a 3- or 5-skill level DAFSC, with 89 percent holding the 5-skill level. None are assigned overseas. The average time in service is 47 months.

XIV. TECHNICAL SCHOOL INSTRUCTORS (GRP035). Nine of these ten individuals are Technical School Instructors stationed at Lowry AFB CO; one is a training supervisor. Most teach basic avionics and electronics principles to new personnel. All are assigned to ATC, have an average grade of E-5, and perform only 18 tasks. Typical tasks include:

- Evaluate progress of students
- Conduct formal classroom instruction
- Prepare lesson plans
- Write test questions
- Maintain training records, charts, or graphs

Comparisons of Specialty Jobs

The Attack Control Avionics Systems jobs identified vary greatly in many respects (size of group, tasks performed, experience, etc.). Table 7 summarizes selected types of information about the individuals in each job group. The F/FB-111 and F-15 Technical Maintenance job groups are the largest groups (200 and 114), with the F-16 Technical Maintenance job group being somewhat smaller (70 people). These differences are, of course, a function of the relative number of aircraft in the Air Force inventory.

The average number of tasks performed by members also varies greatly among the various job groups. F/FB-111 Technical Maintenance Personnel perform, on the average, more tasks than do the F-15 and F-16 technical maintenance groups (120 versus 107 and 98, respectively). The F/FB-111 Technician-Supervisors perform an average of 208 tasks, which suggests they are doing a full range of technical tasks as well as supervisory tasks.

The group performing the most tasks is the Instrument, Attack, and Flight Control Systems Maintenance personnel job group, who average 360 tasks. In the earlier description of this job group, it was noted that this small group (N=12) is the only group performing maintenance on all three aircraft systems, as well as performing AFS 326X7 and 326X8 tasks. Thus, while most AFS 326X6 jobs are focused on one system (or model), there are a few "generalist" jobs where incumbents work on many avionics systems. These jobs are in research settings (AFSC), as well as in operational commands (TAC and USAFE).

A review of Duty AFSC data for the job groups did not reveal any unusual patterns. Analysis of shredouts for various job groups reflected only one B-shred (F-15) individual reporting assignment to an F/FB-111 job and no C-shred personnel misutilization within the F-16 maintenance job was apparent. In the F-15 job group, seven individuals (6 A-shred and one C-shred) are mismatched. Overall, this suggests only very limited mismatching within the major technical job groups.

Table 8 summarizes job attitudes for members of Avionics Attack Control Systems jobs. In terms of job interest, most groups have a high percentage of members who feel their work is interesting. The instructors (Technical School and FTD units) generally have the highest percentage. Administrative Managers and Debriefers have the lowest percentages of those finding their job interesting (33 and 45 percent).

In response to questions concerning how well their present job utilizes their talents and their training, most job group incumbents appear to have fairly positive attitudes. Some of the support jobs, such as DIFM Monitors and QC personnel felt their training was not being used well in their present jobs. (Interestingly, however, most of the DIFM Monitors and QC personnel felt that their talents were well used).

In terms of reenlistment intentions, the job groups varied considerably. Most FTD Instructors were planning to reenlist (67 to 100 percent) but only 40 percent of the Technical School Instructors. In the three primary technical job groups, the majority of incumbents indicate they will not reenlist. Considering that these technical job groups are predominately first enlistment personnel (see Table 7), lower percentages are to be expected. One other job group is worthy of note: none of the DIFM monitors plan to reenlist. This job is also a first-enlistment group (80 percent) and it is a very small group (N=5). Also, this job is very limited (average of 24 tasks), which may not require a highly trained Avionics Specialist.

Overall, there are very few trends in the data which would suggest any problem with the present structure of the career ladder.

TABLE 7
BACKGROUND INFORMATION FOR CLUSTERS AND INDEPENDENT JOB TYPES

	F/FB-111 TECHNICAL PERSONNEL (GRP099)		F/FB-111 FTD INSTRUCTORS (GRP103)		F-111 TECHNICIAN- SUPERVISORS (GRP100)		F-15 TECHNICAL MAINTENANCE PERSONNEL (GRP079)		F-15 FTD INSTRUCTORS (GRP091)		F-16 TECHNICAL MAINTENANCE PERSONNEL (GRP097)		F-16 FTD INSTRUCTORS (GRP073)		INSTRUMENT, ATTACK AND FLIGHT CONTROL SYSTEMS MAINT PERSONNEL (GRP048)	
	NUMBER	PERCENT	NUMBER	PERCENT	NUMBER	PERCENT	NUMBER	PERCENT	NUMBER	PERCENT	NUMBER	PERCENT	NUMBER	PERCENT	NUMBER	PERCENT
NUMBER IN GROUP	200		8	0%	6	0%	114	57%	7	0%	70	35%	9	0%	12	6%
AVERAGE NUMBER OF TASKS PERFORMED	120		96	0%	208	17%	107	70%	82	0%	98	67%	63	0%	360	300%
PERCENT IN FIRST ENLISTMENT	69%		0%	0%	17%	33%	70%	35%	0%	0%	67%	0%	0%	0%	33%	33%
PERCENT LOCATED OVERSEAS	33%		0%	0%	33%	33%	35%	35%	0%	0%	0%	0%	0%	0%	25%	25%
DAFSC DISTRIBUTION																
32636	8%		0%	0%	0%	0%	11%	11%	0%	0%	27%	27%	11%	11%	17%	17%
32656	81%		25%	50%	50%	79%	50%	79%	50%	60%	60%	44%	44%	50%	50%	50%
32676	11%		75%	50%	50%	10%	10%	10%	100%	13%	13%	45%	45%	33%	33%	33%
NUMBER IN EACH SERIED																
A-SERIED (F/FB-111)	132		0	0	3	3	6	6	0	0	0	0	0	0	2	2
B-SERIED (F-15)	1		0	0	0	0	65	65	0	0	0	0	0	0	1	1
C-SERIED (F-16)	0		0	0	0	1	1	1	0	0	60	60	3	3	1	1
NO SERIED INDICATED*	67		8	8	3	3	42	42	7	7	10	10	6	6	8	8
AVERAGE GRADE																
AVERAGE TIME IN SERVICE (MONTHS TAPMS)	3.9		5.6	5.6	5.2	5.2	3.8	3.8	5.7	5.7	3.8	3.8	5.6	5.6	4.4	4.4
AVERAGE TIME IN CAREER FIELD (MONTHS)	51		145	145	104	104	46	46	151	151	54	54	148	148	97	97
PERCENT SUPERVISING	27%		13%	13%	83%	83%	28%	28%	43%	43%	28%	28%	11%	11%	67%	67%
PERCENT IN POWO																
PERCENT MEMBERS FEMALE	57%		25%	25%	33%	33%	90%	90%	29%	29%	93%	93%	56%	56%	50%	50%
*NO SERIED AT THE 7-SKILL LEVEL																

TABLE 7 (CONTINUED)

BACKGROUND INFORMATION FOR CLUSTERS AND INDEPENDENT JOB TYPES

	ADMINISTRATIVE MANAGERS (GRPO53)	SUPERVISION & MANAGEMENT PERSONNEL (GRPO30)	DUE-IN-FOR-MAINTENANCE MONITORS (GRPO71)	QUALITY CONTROL (QC) PERSONNEL (GRPO45)	DEBRIEFERS (GRPO28)	TECHNICAL SCHOOL INSTRUCTORS (GRPO35)
NUMBER IN GROUP	6	29	5	10	9	10
AVERAGE NUMBER OF TASKS PERFORMED	34	78	24	27	9	18
PERCENT IN FIRST ENLISTMENT	17%	10%	80%	0%	67%	10%
PERCENT LOCATED OVERSEAS	50%	48%	20%	50%	0%	0%

DAFSC DISTRIBUTION

32636	0%	3%	0%	0%	11%	20%
32656	50%	21%	100%	0%	89%	50%
32676	50%	76%	0%	100%	0%	30%

NUMBER IN EACH SERIED

A-SERIED (F/FB-111)	1	2	3	0	5	4
B-SERIED (F-15)	0	0	2	0	2	0
C-SERIED (F-16)	0	1	0	2	2	0
NO SERIED INDICATED*	5	26	0	8	0	2

AVERAGE GRADE

125	5.3	6.1	4.2	6.0	3.8	5.0
69	173	173	50	186	47	112
67%	78	78	45	61	42	93
	73%	73%	40%	50%	33%	50%

PERCENT IN POMO ORGANIZATION MEMBERS FEMALE

50%	52%	100%	100%	100%	100%	10%
0%	10%	40%	0%	44%	0%	0%

* NO SERIED AT THE 7-SKILL LEVEL

TABLE 8
JOB SATISFACTION INDICATORS FOR CLUSTERS AND INDEPENDENT JOB TYPES

	F/VR-111 TECHNICAL MAINT PERSONNEL (N=200)	F/FB-111 FTD INSTRUCTORS (N=8)	F-111 TECHNICIAN- SUPERVISORS (N=6)	F-15 TECHNICAL MAINTENANCE PERSONNEL (N=114)	F-16 TECHNICAL MAINTENANCE PERSONNEL (N=70)	F-16 FTD INSTRUCTORS (N=9)	INSTRUMENT, ATTACK AND FLIGHT CONTROL SYSTEMS MAINT PERSONNEL (N=12)
<u>EXPRESSED JOB INTEREST:*</u>							
DULL	17%	0%	0%	22%	6%	0%	17%
SO-SO	23%	13%	33%	18%	19%	0%	17%
INTERESTING	60%	87%	50%	58%	74%	89%	58%
<u>PERCEIVED UTILIZATION OF TALENTS:*</u>							
LITTLE OR NOT AT ALL	34%	0%	33%	44%	31%	11%	42%
FAIRLY WELL OR BETTER	66%	100%	50%	55%	67%	89%	58%
<u>PERCEIVED UTILIZATION OF TRAINING:*</u>							
LITTLE OR NOT AT ALL	21%	0%	17%	32%	26%	11%	42%
FAIRLY WELL OR BETTER	78%	100%	67%	67%	71%	89%	58%
<u>REENLISTMENT INTENTIONS:*</u>							
PLAN TO RETIRE	1%	0%	0%	1%	1%	33%	6%
PLAN NOT TO REENLIST	62%	0%	32%	57%	52%	0%	59%
PLAN TO REENLIST	37%	100%	50%	42%	46%	67%	33%

*SOME COLUMNS DO NOT TOTAL 100% DUE TO OMITTED RESPONSES

TABLE 8 (CONTINUED)
 JOB SATISFACTION INDICATORS FOR CLUSTERS AND INDEPENDENT JOB TYPES

	ADMINISTRATIVE MANAGERS (N=6)	SUPERVISION & MANAGEMENT PERSONNEL (N=29)	DUE-IN-FOR-MAINTENANCE MONITORS (N=5)	QUALITY CONTROL (QC) PERSONNEL (N=10)	DEBRIEFERS (N=9)	TECHNICAL SCHOOL INSTRUCTORS (N=10)
<u>EXPRESSED JOB INTEREST:*</u>						
DULL	33%	17%	0%	10%	22%	10%
SO-SO	33%	14%	40%	10%	33%	10%
INTERESTING	33%	69%	60%	80%	45%	80%
<u>PERCEIVED UTILIZATION OF TALENTS:*</u>						
LITTLE OR NOT AT ALL	50%	17%	20%	30%	56%	30%
FAIRLY WELL OR BETTER	50%	79%	80%	70%	44%	70%
<u>PERCEIVED UTILIZATION OF TRAINING:*</u>						
LITTLE OR NOT AT ALL	50%	52%	80%	60%	44%	50%
FAIRLY WELL OR BETTER	50%	46%	20%	40%	44%	50%
<u>REENLISTMENT INTENTIONS:*</u>						
PLAN TO RETIRE	17%	28%	0%	30%	0%	0%
PLAN NOT TO REENLIST	50%	17%	100%	10%	44%	60%
PLAN TO REENLIST	33%	55%	0%	60%	56%	40%

* SOME COLUMNS DO NOT TOTAL 100% DUE TO OMITTED RESPONSES

ANALYSIS OF DAFSC GROUPS

In conjunction with identifying the job structure of the 326X6 specialty, it is also important to examine differences among survey respondents with respect to their skill level progression. The DAFSC analysis allows for the identification of similarities and differences among the skill levels within each shred as well as across shreds. This information is also useful in evaluating how well career ladder documents, such as AFR 39-1 Specialty Descriptions and the Specialty Training Standards (STS), reflect the tasks and jobs which specialty members perform in the field.

As mentioned in the INTRODUCTION, the 326X6 career ladder is shredded through the 5-skill level according to aircraft maintained. DAFSC 32636 and 32656 personnel with an A-shred maintain F/FB-111 aircraft; those with a B-shred maintain F-15 aircraft; and those with a C-shred maintain F-16 aircraft. Seven-skill level personnel are assigned to any aircraft system and do not carry a suffix.

As is typical in many career ladders, incumbents upgrade from the 3-skill level to the 5-skill level within the first year of their entry into the 326X6 career ladder. Consequently, the job performed by both 3- and 5-skill level incumbents is very similar. Therefore, the 3- and 5-skill levels for this AFSC are discussed as one group for each shred.

DAFSC 32636A and 32656A

These 206 personnel perform flightline maintenance on the integrated avionics attack control systems of F/FB-111 aircraft. The models most widely maintained are the F-111A, F-111D, F-111E, F-111F, and FB-111 aircraft. Less than one percent maintain the EF-111 aircraft. Most incumbents are found in the F/FB-111 Technical Maintenance cluster discussed in the CAREER LADDER STRUCTURE section. Most of their job time is spent in the technical flightline maintenance of terrain following radar (TFR), attack radar systems (ARS), and low altitude radar altimeter (LARA) systems and in performing general avionics maintenance. Test equipment used by these respondents is listed in Table 9.

DAFSC 32636B and 32656B

These 96 incumbents perform flightline maintenance on the F-15 integrated avionics attack control systems. The F-15A and F-15B models are the most widely maintained, although C and D models are also maintained by smaller numbers of B-shred incumbents. These members are found primarily in the F-15 Technical Maintenance cluster and work on APG-63 radar systems, vertical situation display (VSD) or multiple indicator control panel (MICP) systems, and central computers. Electrical connector aircraft wiring repair tool kits (DCM-216), proximity control switch test boxes, radar signal simulator test sets, and RF transmission line test sets were all used by a large number of B-shred incumbents (see Table 9).

DAFSC 32636C and 32656C

These 73 incumbents maintain the integrated avionics attack control systems on the F-16A and F-16B aircraft. Like their counterparts in the A and B shreds, most of their job is technical. Systems unique to this group include fire control radar (FCR), radar electro-optical (REO), and fire control computer (FCC) systems. These respondents also use a noticeably smaller amount of test equipment than either A- or B-shred personnel (see Table 9). Pressurization test sets are the only pieces of test equipment used by a sizeable number of respondents.

AFS 326X6A/326X6B/326X6C Shred Comparisons

An overall comparison across the three shreds indicates both similarities and differences. Much of the work performed by incumbents in all three shreds is the same, consisting of performing technical maintenance on avionics attack control systems. The major differentiating factor among the shreds is the aircraft specific systems on which they perform this maintenance.

A common core of tasks is performed by members of all three shreds. These tasks, listed in Table 10, relate primarily to general avionics maintenance, filling out forms, and performing some supervisory functions.

Table 11 lists aircraft specific tasks which best differentiate between the various shreds. Terrain following radar tasks are performed almost exclusively by A-shred personnel. Many of the systems maintained by B-shred personnel are also maintained by small numbers of both A and C shred incumbents. A smaller amount of A- and B-shred personnel were maintaining FCR systems, along with the C-shred workers, but very few were also maintaining REO systems. Heads up display (HUD) systems, while not reflected in the table, are maintained substantially by both B- and C-shred incumbents but not as much by A-shred personnel.

DAFSC 32676

These 125 members perform technical flightline maintenance as well as supervisory functions. Sixty-six percent report that they maintain aircraft systems while the remaining 34 percent did not perform actual flightline systems maintenance. In terms of the career ladder structure analysis, 43 percent of the 7-skill level respondents grouped in nontechnical job groups (i.e., administrative managers, supervision and management personnel, instructors, etc.). Consequently, 7-skill level personnel hold more diverse jobs than do 5-skill level personnel. This is further emphasized when examining Table 12, which lists representative tasks performed by group members. No task is performed by more than 67 percent of all 7-levels. Table 13 provides an indication of the areas differentiating 3- and 5-skill level workers from 7-skill level technicians. As could be expected, the most noticeable difference is that the technicians generally perform more supervisory and managerial tasks than do the 3- and 5-skill level workers.

Summary

Technical personnel in the 326X6 career ladder perform basically similar jobs, but there are some differences in the jobs performed maintaining the different types of aircraft. With advancement in the career ladder, personnel begin performing more managerial and supervisory functions. Personnel having their 7-skill level DAFSC may do a combination of technical and supervisory-managerial work or they may perform a totally managerial-supervisory job involving no technical maintenance.

DAFSC 32636C and 32656C

These 73 incumbents maintain the integrated avionics attack control systems on the F-16A and F-16B aircraft. Like their counterparts in the A and B shreds, most of their job is technical. Systems unique to this group include fire control radar (FCR), radar electro-optical (REO), and fire control computer (FCC) systems. These respondents also use a noticeably smaller amount of test equipment than either A- or B-shred personnel (see Table 9). Pressurization test sets are the only pieces of test equipment used by a sizeable number of respondents.

AFS 326X6A/326X6B/326X6C Shred Comparisons

An overall comparison across the three shreds indicates both similarities and differences. Much of the work performed by incumbents in all three shreds is the same, consisting of performing technical maintenance on avionics attack control systems. The major differentiating factor among the shreds is the aircraft specific systems on which they perform this maintenance.

A common core of tasks is performed by members of all three shreds. These tasks, listed in Table 10, relate primarily to general avionics maintenance, filling out forms, and performing some supervisory functions.

Table 11 lists aircraft specific tasks which best differentiate between the various shreds. Terrain following radar tasks are performed almost exclusively by A-shred personnel. Many of the systems maintained by B-shred personnel are also maintained by small numbers of both A and C shred incumbents. A smaller amount of A- and B-shred personnel were maintaining FCR systems, along with the C-shred workers, but very few were also maintaining REO systems. Heads up display (HUD) systems, while not reflected in the table, are maintained substantially by both B- and C-shred incumbents but not as much by A-shred personnel.

DAFSC 32676

These 125 members perform technical flightline maintenance as well as supervisory functions. Sixty-six percent report that they maintain aircraft systems while the remaining 34 percent did not perform actual flightline systems maintenance. In terms of the career ladder structure analysis, 43 percent of the 7-skill level respondents grouped in nontechnical job groups (i.e., administrative managers, supervision and management personnel, instructors, etc.). Consequently, 7-skill level personnel hold more diverse jobs than do 5-skill level personnel. This is further emphasized when examining Table 12, which lists representative tasks performed by group members. No task is performed by more than 67 percent of all 7-levels. Table 13 provides an indication of the areas differentiating 3- and 5-skill level workers from 7-skill level technicians. As could be expected, the most noticeable difference is that the technicians generally perform more supervisory and managerial tasks than do the 3- and 5-skill level workers.

Summary

Technical personnel in the 326X6 career ladder perform basically similar jobs, but there are some differences in the jobs performed maintaining the different types of aircraft. With advancement in the career ladder, personnel begin performing more managerial and supervisory functions. Personnel having their 7-skill level DAFSC may do a combination of technical and supervisory-managerial work or they may perform a totally managerial-supervisory job involving no technical maintenance.

TABLE 9

TEST EQUIPMENT USED AND AVIONICS SYSTEMS INSPECTIONS PERFORMED BY DAFSC GROUPS
(PERCENT MEMBERS USING OR PERFORMING)*

TEST EQUIPMENT USED	32636,56A PERSONNEL (N=206)	32636,56B PERSONNEL (N=96)	32636,56C PERSONNEL (N=73)	32676 PERSONNEL (N=125)
AUTOMATIC FLIGHTLINE TEST SETS	25	3	0	9
ELECTRICAL CONNECTOR AIRCRAFT WIRING REPAIR TOOL KITS (DCM-216)	42	63	15	34
PRESSURIZATION TEST SETS	73	47	40	56
PROXIMITY CONTROL SWITCH TEST BOXES	2	43	0	14
RADAR SIGNAL SIMULATOR TEST SETS	17	63	4	17
RF TRANSMISSION LINE TEST SETS	10	31	6	12
SUBSYSTEM TIE-IN TEST SETS	52	1	0	29
INCLINOMETERS (TB 100)	7	5	11	17
TTU-205 C/E PITOT STATIC SYSTEM TESTERS	8	2	0	12
NONE	14	12	34	42
INSPECTIONS PERFORMED				
FOD INSPECTIONS	45	59	47	53
AIRCRAFT ACCEPTANCE INSPECTIONS	10	40	55	27
PHASE INSPECTIONS	51	67	19	35
780 INSPECTIONS	18	12	15	24
NONE	25	18	25	31

*ONLY EQUIPMENT USED AND INSPECTIONS PERFORMED BY OVER 10 PERCENT OF ANY OF THE LISTED GROUPS IS INCLUDED IN THIS TABLE

TABLE 10

COMMON TASKS PERFORMED BY DAFSC 32636 AND 32656 PERSONNEL

TASKS	PERCENT MEMBERS PERFORMING (N=428)
F191 OPERATE AGE, SUCH AS POWER UNITS, HEATERS, COOLING UNITS, OR LIGHT CARTS	86
I304 REMOVE OR INSTALL INS SYSTEM LRUs	84
F186 ADJUST AVIONIC SYSTEMS MINOR HARDWARE SUCH AS SCREWS OR CONTROL KNOBS	83
F187 INTERPRET AIRCRAFT INTERCONNECTING WIRING DIAGRAMS	81
F222 REMOVE OR INSTALL WAVE GUIDES	81
E149 MAKE ENTRIES ON MAINTENANCE DATA COLLECTION RECORD (AFTO FORM 349)	81
F211 REMOVE OR INSTALL AVIONIC SYSTEMS MINOR HARDWARE SUCH AS SCREWS OR CONTROL KNOBS	81
F214 REMOVE OR INSTALL CANNON-PLUG CONNECTORS	76
F190 ISOLATE MALFUNCTIONS TO DEFECTIVE INTERCONNECTING WIRING	76
E164 MAKE ENTRIES ON REPARABLE ITEM PROCESSING TAG (AFTO FORM 350)	73
F209 PRESSURE TEST WAVE GUIDE ASSEMBLIES	72
E151 MAKE ENTRIES ON MAINTENANCE DISCREPANCY AND WORK DOCUMENT FORMS (AFTO FORM 781A)	71
G254 OPERATE ATTACK RADAR SYSTEMS	70
F205 PERFORM SAFETY WIRING	69

TABLE 11

EXAMPLE TASKS WHICH BEST DIFFERENTIATE AMONG 3- AND 5-SKILL LEVEL A, B, AND C SHRED PERSONNEL
(PERCENT MEMBERS PERFORMING)

TASK	32636,56A PERSONNEL	32636,56B PERSONNEL	32636,56C PERSONNEL
H294 REMOVE OR INSTALL TFR SYSTEM LINE REPLACEABLE UNITS (LRU)	81	2	1
H284 ISOLATE MALFUNCTIONS TO TFR COMPUTERS	80	2	1
M283 ISOLATE MALFUNCTIONS TO TFR ANTENNA-RECEIVERS	80	2	1
H280 ADJUST TERRAIN FOLLOWING RADAR (TFR) ANTENNA-RECEIVERS	77	2	3
M388 PERFORM OPERATIONAL CHECKS OF LOW ALTITUDE RADAR ALTIMETER (LARA) SYSTEMS	80	5	1
F206 PERFORM TERRAIN FOLLOWING RADAR (TFR) AND FLIGHT CONTROL TIE-IN CHECKS	77	5	3
H289 ISOLATE MALFUNCTIONS TO TFR SYNCHRONIZER-TRANSMITTERS	80	1	1
M389 REMOVE OR INSTALL LARA SYSTEM LRUs	79	5	1
M386 ISOLATE MALFUNCTIONS TO LARA RECEIVER-TRANSMITTERS	77	4	1
I301 ISOLATE MALFUNCTIONS TO INS INERTIAL REFERENCE UNITS	81	41	48
G276 REMOVE OR INSTALL ATTACK RADAR SYSTEMS (ARS) SYSTEM LRUs	73	23	27
G275 REMOVE OR INSTALL APG-63 RADAR SET LRUs	7	78	11
G228 INTERPRET BUILT-IN-TEST (BIT) RESULTS ON APG-63 RADAR SETS	12	80	15
G231 INTERPRET BIT RESULTS ON VERTICAL SITUATION DISPLAY (VSD) OR MULTIPLE INDICATOR CONTROL PANEL (MCP) SYSTEMS	19	83	5
G279 REMOVE OR INSTALL VSD OR MICP LRUs	20	81	3
G259 PERFORM ANTENNA HYDRAULIC LEAKAGE INSPECTIONS	4	83	7
J339 REMOVE OR INSTALL CENTRAL COMPUTERS	14	80	8
K361 PERFORM BIT ON LEAD COMPUTING GYROS	7	79	12
J333 PERFORM DATA ENTRY TO CENTRAL COMPUTERS	22	77	23
J332 PERFORM BIT ON CENTRAL COMPUTERS	19	83	22
G261 PERFORM BIT ON FIRE CONTROL RADAR (FCR) SYSTEMS	5	14	86
G229 INTERPRET BIT RESULTS ON FCR SYSTEMS	12	25	89
G247 ISOLATE MALFUNCTIONS TO FCR SYSTEM LRUs	10	19	85
G230 INTERPRET BIT RESULTS ON RADAR ELECTRO-OPTICAL (REO) SYSTEMS	5	14	88
G277 REMOVE OR INSTALL FCR SYSTEM LRUs	4	8	81
G265 PERFORM FCR INTEGRATION CHECKS	6	10	84
G278 REMOVE OR INSTALL REO SYSTEM LRUs	2	5	85
G249 ISOLATE MALFUNCTIONS TO REO INDICATOR UNITS	4	9	88
G272 PERFORM OPERATIONAL CHECKS OF REO DISPLAY SYSTEMS	3	5	88

TABLE 12

REPRESENTATIVE TASKS PERFORMED BY DAFSC 32676 PERSONNEL

TASKS	PERCENT MEMBERS PERFORMING (N=125)
C96 PREPARE APRs	67
F187 INTERPRET AIRCRAFT INTERCONNECTING WIRING DIAGRAMS	67
E151 MAKE ENTRIES ON MAINTENANCE DISCREPANCY AND WORK DOCUMENT (AFTO FORM 781A)	66
C97 PROVIDE TECHNICAL ASSISTANCE FOR JOB RELATED PROBLEMS ENCOUNTERED BY SUBORDINATES	65
B29 COUNSEL PERSONNEL ON PERSONAL OR MILITARY RELATED PROBLEMS	65
E155 MAKE ENTRIES ON ON-THE-JOB TRAINING RECORD CONTINUATION SHEET (AF FORM 623A)	64
D112 DEMONSTRATE HOW TO LOCATE TECHNICAL INFORMATION	63
E164 MAKE ENTRIES ON REPARABLE ITEM PROCESSING TAG (AFTO FORM 350)	63
F191 OPERATE AGE, SUCH AS POWER UNITS, HEATERS, COOLING UNITS, OR LIGHT CARTS	60
F190 ISOLATE MALFUNCTIONS TO DEFECTIVE INTERCONNECTING WIRING	58
A3 COORDINATE WORK WITH OTHER SECTIONS	57
E156 MAKE ENTRIES ON ON-THE-JOB TRAINING RECORD (AF FORM 623)	57
E146 MAKE ENTRIES ON JOB PROFICIENCY GUIDE CONTINUATION SHEET (AF FORM 623)	57
D113 DEMONSTRATE OPERATION OF EQUIPMENT	55
D111 COUNSEL INDIVIDUALS ON TRAINING PROGRESS	54

TABLE 13

EXAMPLES OF TASKS WHICH BEST DIFFERENTIATE SKILL LEVEL PERSONNEL
(PERCENT MEMBERS PERFORMING)

TASKS	32636/56X PERSONNEL (N=429)	32676 PERSONNEL (N=125)	DIFFERENCE
F222 REMOVE OR INSTALL WAVE GUIDES	81	50	31
F211 REMOVE OR INSTALL AVIONIC SYSTEMS MINOR HARDWARE SUCH AS SCREWS OR CONTROL KNOBS	81	50	31
F205 PERFORM SAFETY WIRING	69	38	31
F186 ADJUST AVIONIC SYSTEMS MINOR HARDWARE SUCH AS SCREWS OR CONTROL KNOBS	83	54	29
I304 REMOVE OR INSTALL INS SYSTEM LRUs	84	56	28
F215 REMOVE OR INSTALL COAXIAL CABLES	71	43	28
I303 ISOLATE MALFUNCTIONS TO INS NAVIGATIONAL COMPUTERS	63	36	27
G243 ISOLATE MALFUNCTIONS TO ARS RADAR SET CONTROLS	59	32	27
G276 REMOVE OR INSTALL ARS SYSTEM LRUs	51	26	25
I299 ISOLATE MALFUNCTIONS TO INS BATTERY UNITS	63	38	25
F209 PRESSURE TEST WAVE GUIDE ASSEMBLIES	72	47	25
G235 ISOLATE MALFUNCTIONS TO ARS ANTENNAS	62	37	25
A5 DETERMINE WORK PRIORITIES	30	51	-21
D112 DEMONSTRATE HOW TO LOCATE TECHNICAL INFORMATION	37	63	-26
E155 MAKE ENTRIES ON ON-THE-JOB TRAINING RECORD CONTINUATION SHEET (AF FORM 623A)	36	64	-28
B39 INDOCTRINATE NEWLY ASSIGNED PERSONNEL	21	51	-30
D111 COUNSEL INDIVIDUALS ON TRAINING PROGRESS	21	54	-33
A3 COORDINATE WORK WITH OTHER SECTIONS	23	57	-34
C97 PROVIDE TECHNICAL ASSISTANCE FOR JOB RELATED PROBLEMS ENCOUNTERED BY SUBORDINATES	30	65	-35
B29 COUNSEL PERSONNEL ON PERSONAL OR MILITARY RELATED PROBLEMS	22	65	-43
E146 MAKE ENTRIES ON JOB PROFICIENCY GUIDE CONTINUATION SHEET (AF FORM 797)	20	64	-44
C96 PREPARE APRs	22	67	-45

COMPARISON OF SURVEY DATA TO AFR 39-1 SPECIALTY DESCRIPTIONS

To verify the accuracy and comprehensiveness of the 326X6 specialty descriptions, occupational survey data were compared to the March 1979 AFR 39-1 Specialty Descriptions. Overall, the 326X6 specialty descriptions are accurate representations of the general tasks performed by 3-, 5-, and 7-skill level personnel. Aircraft specific tasks are not listed since the diversity of aircraft models and avionics systems would make the descriptions too detailed and lengthy. The specialty descriptions serve well as general job descriptions for which they are intended and no changes are recommended at this time.

ANALYSIS OF TRAINING

One of the major objectives of this project was to collect occupational data for use in reviewing present initial skill training programs. The target population for such training programs are those Avionics Attack Control System personnel who are in their first enlistment.

Twenty-four 7-skill level Technicians rated the Job Inventory tasks in terms of which tasks should receive emphasis in structured training for first-term 326X6 personnel (0=no training to 9=very heavy emphasis in training). Unfortunately, raters did not agree to an acceptable degree on which tasks should be trained. No systematic trends could be identified which would account for the lack of agreement among TE raters.

A second group of 25 senior technicians provided Task Difficulty (TD) ratings which are estimates of which tasks are more difficult to learn. These TD raters also did not agree to an acceptable level and no reasons for this lack of agreement could be identified.

The lack of reliable TE and TD ratings limits analysis of training documents and programs. Thus, this section will focus on identifying the tasks performed by first-enlistment personnel and reviewing the equipment first-enlistment personnel use.

Figure 2 portrays the different jobs performed by first-enlistment personnel. Since the jobs closely parallel the AFSC shredouts, it is appropriate to examine the job descriptions of each shredout group. (Note: For the sake of brevity, only example tasks are displayed in this report. Training officials have been provided with a complete listing for use in training reviews and the data are also included in the 326X6 computer product EXTRACT.)

Analysis of 326X6A First Enlistment Personnel

Representative tasks performed by 326X6A first-enlistment personnel are presented in Table 14. The 142 first-term incumbents in the A-shred spend the majority of their time (80 percent) performing technical tasks. General avionics maintenance functions, such as operating AGE, adjusting avionics systems minor hardware, and interpreting aircraft interconnecting wiring diagrams, comprise much of their work time. Aircraft specific tasks performed relate to maintaining terrain following radar (TFR) systems and low altitude radar altimeter (LARA) systems.

As illustrated in Table 17, A-shred first-enlistment personnel most commonly use pressurization test sets, subsystem tie-in test sets, electrical connector aircraft wiring repair tool kits (DCM-216), and automatic flightline test sets in performing their jobs. Of these, the subsystem tie-in and automatic flightline test sets were used primarily by A-shred personnel and very few B- and C-shred members. Test equipment least used by A-shred first-enlistment members were inclinometers (TB 100) and TTU-205 C/E pitot static system testers.

Analysis of 326X6B First Enlistment Personnel

Table 15 provides a listing of representative tasks for 326X6B first-enlistment personnel. The 77 first-term personnel in the 326X6B career ladder also perform an almost exclusively technical job. Members spend approximately 78 percent of their job time performing general avionics tasks, such as operating AGE, and performing flightline maintenance on APG-63 radar sets, inertial navigation systems, vertical situation displays (VSD) or multiple indicator control panel (MICP) systems, and central computers.

Referencing Table 17, B-shred first enlistment personnel use electrical connector aircraft wiring repair tool kits (DCM-216), pressurization test sets, proximity control switch test boxes, radar signal simulator test sets, and RF transmission line test sets. The latter three pieces of test equipment tend to be used by substantially higher percentages of B-shred personnel as opposed to A- or C-shred first enlistment incumbents. B-shred first enlistment personnel seem to utilize more test equipment than the other shreds in that they have five pieces of test equipment with over 25 percent member utilization as opposed to only four pieces for A-shred personnel and one piece for C-shred personnel.

Analysis of 326X6C First Enlistment Personnel

As with the A-shred and B-shred incumbents with less than 49 months TAFMS, the C-shred first enlistment members--numbering 51--report a highly technical job of flightline maintenance. F-16 systems they typically maintain on the flightline are radar electro-optical (REO) systems, inertial navigation systems, fire control computers, and heads-up display (HUD) systems. Operating AGE is also a major portion of their job. Table 16 provides a listing of representative tasks for this group.

Table 17 reveals that C-shred first enlistment personnel tend to utilize only one piece of the listed equipment - pressurization test sets. As indicated, 35 percent of these incumbents indicate utilizing no test equipment at all in their present job. This contrasts with only 11 percent of the A-shred first enlistment group and only 10 percent of the B-shred first enlistment group.

Analysis of Specialty Training Standards (STS)

On the basis of the examination of the 326X6A, 326X6B, and 326X6C STSs, dated either April or December 1979, no areas were identified that need revision. A listing of the tasks not referenced to each of these STSs is available in Appendix C.

The 326X6A, 326X6B, and 326X6C STSs were individually matched to the tasks in the 326X6 job inventory by the 326X6 career ladder training manager. This matching consists of taking the STS item by item and identifying corresponding tasks in the job inventory which relate to the STS item.

Each task in the inventory is listed along with the percentage of first job, first enlistment, 5-skill level, 7-skill level, and total 326X6 personnel in the specified shred (no shred for 7-skill level) who reported performing it. Each item in the STS can then be examined on the basis of what percentage of these groups perform tasks related to the specific STS item. STS items which have no members performing related OSR tasks may possibly be deleted from the STS. In the same way, tasks not referenced to the STS which have a high percentage of personnel performing them may need to be added to the STS, depending on the nature of the task and whether it can be matched to an STS item.

FIGURE 2

DISTRIBUTION OF FIRST ENLISTMENT PERSONNEL
ACROSS CAREER LADDER JOBS
(PERCENT MEMBERS RESPONDING)
(N=305)

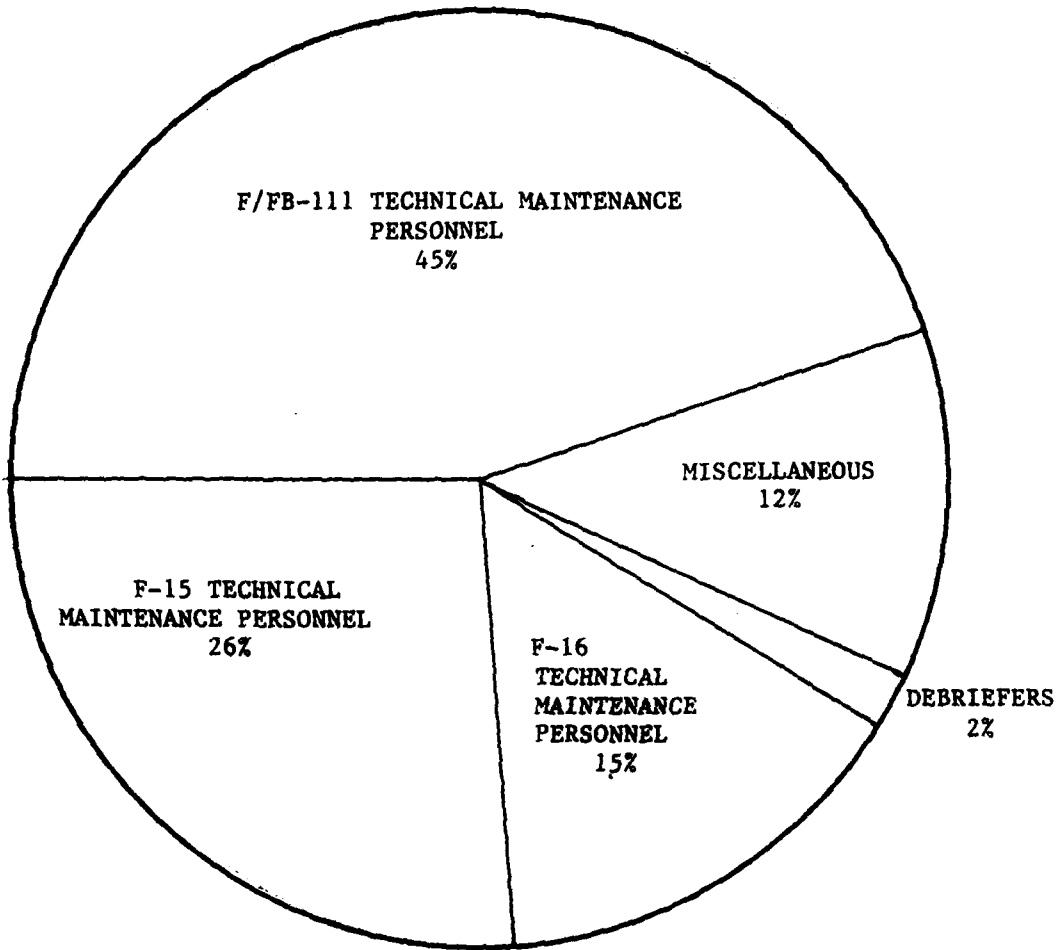

TABLE 14

REPRESENTATIVE TASKS PERFORMED BY 326X6A FIRST ENLISTMENT PERSONNEL
(N=142)

TASKS	PERCENT MEMBERS PERFORMING
F186 ADJUST AVIONIC SYSTEMS MINOR HARDWARE SUCH AS SCREWS OR CONTROL KNOBS	88
I304 REMOVE OR INSTALL INS SYSTEM LRUs	87
F191 OPERATE AGE, SUCH AS POWER UNITS, HEATERS, COOLING UNITS, OR LIGHT CARTS	87
F187 INTERPRET AIRCRAFT INTERCONNECTING WIRING DIAGRAMS	87
F222 REMOVE OR INSTALL WAVE GUIDES	86
E149 MAKE ENTRIES ON MAINTENANCE DATA COLLECTION RECORD (AFTO FORM 349)	85
F211 REMOVE OR INSTALL AVIONIC SYSTEMS MINOR HARDWARE SUCH AS SCREWS OR CONTROL KNOBS	85
I301 ISOLATE MALFUNCTIONS TO INS INERTIAL REFERENCE UNITS OR STABILIZED PLATFORMS	85
I303 ISOLATE MALFUNCTIONS TO INS NAVIGATIONAL COMPUTERS	85
H282 ISOLATE MALFUNCTIONS TO TFR AMPLIFIER-POWER SUPPLIES	83
G235 ISOLATE MALFUNCTIONS TO ARS ANTENNAS	83
H294 REMOVE OR INSTALL TFR SYSTEM LRUs	82
H284 ISOLATE MALFUNCTIONS TO TFR COMPUTERS	82
H283 ISOLATE MALFUNCTIONS TO TFR ANTENNA-RECEIVERS	82
M388 PERFORM OPERATIONAL CHECKS OF LARA SYSTEMS	82
H289 ISOLATE MALFUNCTIONS TO TFR SYNCHRONIZER-TRANSMITTERS	82
G234 ISOLATE MALFUNCTIONS TO ARS ANTENNA PEDESTALS	82
H285 ISOLATE MALFUNCTIONS TO TFR ELECTRICAL EQUIPMENT RACKS	82
H287 ISOLATE MALFUNCTIONS TO TFR LOW ALTITUDE MONITORS (LAM)	82
H288 ISOLATE MALFUNCTIONS TO TFR RADAR CONTROLS	82
F223 REPAIR WIRING	82
F206 PERFORM TERRAIN FOLLOWING RADAR (TFR) AND FLIGHT CONTROL TIE-IN CHECKS	81
M389 REMOVE OR INSTALL LARA SYSTEM LRUs	81
G232 ISOLATE MALFUNCTIONS TO ARS ANTENNA CONTROL UNITS	81
M386 ISOLATE MALFUNCTIONS TO LARA RECEIVER-TRANSMITTERS	81
M383 ISOLATE MALFUNCTIONS TO LARA RADAR ALTITUDE INDICATORS	81
G254 OPERATE ATTACK RADAR SYSTEMS	80
G227 ADJUST ATTACK RADAR SYSTEMS (ARS) INDICATOR RECORDER CURSOR OR INTENSITIES	80
H281 ADJUST TFR FREQUENCY SPREADS	80
F209 PRESSURE TEST WAVE GUIDE ASSEMBLIES	80
F205 PERFORM SAFETY WIRING	80
H280 ADJUST TERRAIN FOLLOWING RADAR (TFR) ANTENNA RECEIVERS	80

TABLE 15

REPRESENTATIVE TASKS PERFORMED BY 326X6B FIRST ENLISTMENT PERSONNEL
(N=77)

TASKS	PERCENT MEMBERS PERFORMING
F191 OPERATE AGE, SUCH AS POWER UNITS, HEATERS, COOLING UNITS, OR LIGHT CARTS	88
E149 MAKE ENTRIES ON MAINTENANCE DATA COLLECTION RECORD (AFTO FORM 349)	87
F224 RESET FAULT INDICATOR LATCHES	87
F222 REMOVE OR INSTALL WAVE GUIDES	87
I304 PERFORM OR INSTALL INS SYSTEM LRUs	86
G263 PERFORM BIT ON VSD OR MICP SYSTEMS	86
K370 REMOVE OR INSTALL HUD SYSTEM LRUs	86
K350 ISOLATE MALFUNCTIONS TO HUD PROCESSORS OR ELECTRONIC UNITS	86
G231 INTERPRET BIT RESULTS ON VSD OR MICP SYSTEMS	84
K364 PERFORM OPERATIONAL CHECKS OF HUD SYSTEMS	84
G259 PERFORM ANTENNA HYDRAULIC LEAKAGE INSPECTIONS	84
J332 PERFORM BIT ON CENTRAL COMPUTERS	84
F186 ADJUST AVIONIC SYSTEMS MINOR HARDWARE SUCH AS SCREWS OR CONTROL KNOBS	84
G266 PERFORM MISSILE ANTENNA OR RADOME RADIO FREQUENCY (RF) OUTPUT CHECKS	84
F223 REPAIR WIRING	84
G279 REMOVE OR INSTALL VSD OR MICP LRUs	83
F205 PERFORM SAFETY WIRING	83
J339 REMOVE OR INSTALL CENTRAL COMPUTERS	83
F214 REMOVE OR INSTALL CANNON-PLUG CONNECTORS	83
K359 PERFORM BIT ON HUD GUN SIGHT CAMERAS	82
K348 ISOLATE MALFUNCTIONS TO HUD CAMERAS	82
F220 REMOVE OR INSTALL INSTRUMENT GLARE SHIELDS	82
F187 INTERPRET AIRCRAFT INTERCONNECTING WIRING DIAGRAMS	82
G228 INTERPRET BUILT-IN-TEST (BIT) RESULTS ON APG-63 RADAR SETS	81
G260 PERFORM BIT ON APG-63 RADAR SETS	81
F208 PLUG OR CAP ELECTRICAL OR AIR LINES	81
K360 PERFORM BIT ON HUD SYSTEMS OTHER THAN GUN SIGHT CAMERAS	81
K361 PERFORM BIT ON LEAD COMPUTING GYROS	81
F211 REMOVE OR INSTALL AVIONIC SYSTEMS MINOR HARDWARE SUCH AS SCREWS OR CONTROL KNOBS	81
K372 REMOVE OR INSTALL LEAD COMPUTING GYROS	81
F190 ISOLATE MALFUNCTIONS TO DEFECTIVE INTERCONNECTING WIRING	81

TABLE 16

REPRESENTATIVE TASKS PERFORMED BY 326X6C FIRST ENLISTMENT PERSONNEL
(N=51)

TASKS	PERCENT MEMBERS PERFORMING
G247 ISOLATE MALFUNCTIONS TO FCR SYSTEM LINE REPLACEABLE UNITS (LRU)	96
G249 ISOLATE MALFUNCTIONS TO REO INDICATOR UNITS	96
G229 INTERPRET BIT RESULTS ON FIRE CONTROL RADAR (FCR) SYSTEMS	94
F191 OPERATE AGE, SUCH AS POWER UNITS, HEATERS, COOLING UNITS, OR LIGHT CARTS	94
I304 REMOVE OR INSTALL INS SYSTEM LRUs	94
K349 ISOLATE MALFUNCTIONS TO HUD PILOT DISPLAY UNITS	94
K350 ISOLATE MALFUNCTIONS TO HUD PROCESSORS OR ELECTRONIC UNITS	94
G230 INTERPRET BIT RESULTS ON RADAR ELECTRO-OPTICAL (REO) SYSTEMS	92
G262 PERFORM BIT ON REO SYSTEMS	92
G278 REMOVE OR INSTALL REO SYSTEM LRUs	92
G272 PERFORM OPERATIONAL CHECKS OF REO DISPLAY SYSTEMS	92
K370 REMOVE OR INSTALL HUD SYSTEM LRUs	92
G250 ISOLATE MALFUNCTIONS TO REO SYMBOL GENERATOR ELECTRONIC UNITS	92
F186 ADJUST AVIONIC SYSTEMS MINOR HARDWARE SUCH AS SCREWS OR CONTROL KNOBS	92
G261 PERFORM BIT ON FCR SYSTEMS	90
G265 PERFORM FCR INTEGRATION CHECKS	90
J334 PERFORM FCC INTEGRATION CHECKS	90
G277 REMOVE OR INSTALL FCR SYSTEM LRUs	88
J341 REMOVE OR INSTALL FCC SYSTEM LRUs	88
J323 ISOLATE MALFUNCTIONS TO FIRE CONTROL COMPUTERS (FCC)	88
G248 ISOLATE MALFUNCTIONS TO FCR WAVE GUIDE ASSEMBLIES	88
E149 MAKE ENTRIES ON MAINTENANCE DATA COLLECTION RECORD (AFTO FORM 349)	86
K364 PERFORM OPERATIONAL CHECKS OF HUD SYSTEMS	86
F188 ISOLATE MALFUNCTIONS IN AVIONICS STATUS PANELS	86
I299 ISOLATE MALFUNCTIONS TO INS BATTERY UNITS	86
E164 MAKE ENTRIES ON REPARABLE ITEM PROCESSING TAG (AFTO FORM 350)	84
I297 ISOLATE MALFUNCTIONS TO INERTIAL MEASUREMENT UNITS OR INERTIAL NAVIGATION UNITS	84
K362 PERFORM HUD SYSTEM INTEGRATION CHECKS	84
K351 ISOLATE MALFUNCTIONS TO HUD RATE SENSOR UNITS	84

TABLE 17

**MOST COMMON TEST EQUIPMENT USED AND AVIONICS SYSTEMS INSPECTIONS
PERFORMED BY FIRST ENLISTMENT PERSONNEL
(PERCENT MEMBERS USING OR PERFORMING)**

<u>TEST EQUIPMENT USED</u>	326X6A FIRST ENLISTMENT PERSONNEL (N=142)	326X6B FIRST ENLISTMENT PERSONNEL (N=77)	326X6C FIRST ENLISTMENT PERSONNEL (N=51)
AUTOMATIC FLIGHTLINE TEST SETS	27	4	0
ELECTRICAL CONNECTOR AIRCRAFT WIRING REPAIR TOOL KITS (DCM-216)	41	62	8
PRESSURIZATION TEST SETS	75	49	43
PROXIMITY CONTROL SWITCH TEST BOXES	3	42	0
RADAR SIGNAL SIMULATOR TEST SETS	18	55	4
RF TRANSMISSION LINE TEST SETS	11	30	8
SUBSYSTEM TIE-IN TEST SETS	56	1	0
INCLINOMETERS (TB 100)	5	4	10
TTU-205 C/E PITOT STATIC SYSTEM TESTERS	4	3	0
NONE	11	10	35
 <u>INSPECTIONS PERFORMED</u>			
FOD INSPECTIONS	47	58	49
AIRCRAFT ACCEPTANCE INSPECTIONS	9	40	57
PHASE INSPECTIONS	57	69	22
780 INSPECTIONS	17	12	10
NONE	22	16	18

ANALYSIS OF JOB SATISFACTION

The main function of this section is to describe how job satisfaction indicators change with experience in the career ladder and how they differ between shreds. Table 18 lists the job satisfaction for these groups along with that for a comparative group made up of individuals in other similar maintenance ladders surveyed in 1980. (The comparative group includes AFSS 302X0, 307X0, 308X0, 322X2A/B/C, and 427X3.)

First Enlistment (1-48 Months TAFMS) A-Shred (F/FB-111) Personnel

One hundred and forty-two A-shred first enlistment personnel responded to the survey. Sixty percent of the A-shred group found their job interesting. More than any other 326X6 experience group, A-shred first enlistment incumbents felt that their talents and training were well utilized; however, fewer members of this group reported intentions to reenlist (30 percent).

First Enlistment (1-48 Months TAFMS) B-Shred (F-15) Personnel

The 77 members of this group reported job satisfaction indices similar to those of the A-shred first enlistment group, with the exception being that B-shred first enlistment personnel did not feel that their talents were as well utilized.

First Enlistment (1-48 Months TAFMS) C-Shred (F-16) Personnel

The 51 C-shred first enlistment respondents indicated similar job satisfaction to the two previously discussed A and B-shred groups. C-shred personnel, however, did not find their training as well utilized as did the other first enlistment incumbents. They did report the highest reenlistment intentions of all 326X6 first enlistment personnel.

Second Enlistment (49-96 Months TAFMS) 326X6 Personnel

Slightly more of the 94 second enlistment 326X6 personnel surveyed report an interesting job than their second enlistment counterparts in the comparative sample. Perceived utilization of talents and training are both lower for the 326X6 second enlistment personnel, as are reenlistment intentions.

Perceived utilization of talents is the area with the largest difference between these groups; only 56 percent of the 326X6 group perceive their talents as well utilized as opposed to 69 percent of the comparative sample.

Career Enlistment (97+ Months TAFMS) 326X6 Personnel

The 153 members of the 326X6 career enlistment group have lower job satisfaction in general, but slightly higher reenlistment intentions than the comparative sample of career enlistment personnel. Perceived utilization of training is the greatest difference between the 326X6 and the comparative group; only 61 percent of the 326X6 group feel their training is well utilized as compared to 71 percent of the comparative sample.

Summary

All 326X6 experience groups have similar overall job satisfaction. The career (97+ months TAFMS) 326X6 experience group found their job more interesting than the comparative sample; however, they, along with the 326X6 second enlistment group had some areas of low job satisfaction compared to their respective enlistment groups in the comparative sample. First enlistment personnel in all three shreds had job satisfaction levels similar to the comparative sample.

TABLE 18
 JOB SATISFACTION INDICES FOR EXPERIENCE GROUPS
 (PERCENT MEMBERS RESPONDING)

	FIRST ENLISTMENT A-SHRED (F/FB-111) (N=142)	FIRST ENLISTMENT B-SHRED (F-15) PERSONNEL (N=77)	FIRST ENLISTMENT C-SHRED (F-16) PERSONNEL (N=51)	FIRST ENLISTMENT COMPARATIVE SAMPLE* (N=1,374)	SECOND ENLISTMENT 3261GX PERSONNEL (N=94)	SECOND ENLISTMENT COMPARATIVE SAMPLE* (N=853)	CAREER 3261GX PERSONNEL (N=153)	CAREER COMPARATIVE SAMPLE* (N=1,426)
<u>EXPRESSED JOB INTEREST:</u>								
DULL	17	17	10	24	17	17	17	14
SO-SO	23	21	25	20	19	22	20	16
INTERESTING	60	61	63	56	63	61	63	70
NOT REPORTED	0	1	2	0	1	0	0	0
<u>PERCEIVED UTILIZATION OF TALENTS:</u>								
LITTLE OR NOT AT ALL	32	43	43	37	44	31	30	24
FAIRLY WELL OR BETTER	67	56	55	63	56	69	69	76
NOT REPORTED	1	1	2	0	0	0	1	0
<u>PERCEIVED UTILIZATION OF TRAINING:</u>								
LITTLE OR NOT AT ALL	25	29	31	30	32	28	38	25
FAIRLY WELL OR BETTER	74	70	65	69	67	71	61	75
NOT REPORTED	1	1	4	1	1	1	1	0
<u>REENLISTMENT INTENTIONS:</u>								
PLAN TO RETIRE	0	0	0	**	1	**	13	**
PLAN NOT TO REENLIST	67	69	63	66	56	51	18	31
PLAN TO REENLIST	30	31	35	33	43	48	69	67
NOT REPORTED	3	0	2	1	0	1	0	2

* COMPARATIVE SAMPLE INCLUDES PERSONNEL FROM A NUMBER OF SIMILAR MAINTENANCE CAREER FIELDS SURVEYED IN 1980 (INCLUDES AFS' s 302X0, 307X0, 308X0, 322X2A/B/C, 427X3; TOTAL COMPARATIVE SAMPLE CONTAINED 3,653 RESPONDENTS)

** "PLAN NOT TO REENLIST" INCLUDES "PLAN TO RETIRE" FOR 1980 COMPARATIVE DATA

COMPARISON OF 32656X CONUS AND OVERSEAS GROUPS

Many times, personnel stationed overseas perform a different job than those personnel stationed in the Continental United States (CONUS). Typically, personnel stationed overseas are more experienced and perform more managerial and supervisory tasks on the average. An analysis of the CONUS and overseas groups for the 32656 A-shred (EF/F/FB-111) and B-shred (F-15) personnel was made to examine any differences which might exist. At the time of this report, the U. S. Air Force had no overseas bases with F-16 aircraft, so a comparison of C-shred CONUS and overseas groups could not be made. Only 5-skill level incumbents were compared because those personnel do the major technical maintenance in the career ladder and any technical differences in the jobs performed should surface in this comparison.

32656 A-shred Personnel. Eighty-five percent of the overseas group of DAFSC 32656A personnel were in USAFE, with the rest reporting TAC as their major command. Sixty-five percent of the CONUS group were in TAC, with SAC having an additional 22 percent. The overseas group maintained mostly F-111E and F model aircraft, whereas CONUS personnel maintained F-111A, D, and FB-111A aircraft (see Table 21).

In general, the jobs did not differ substantially between CONUS and overseas groups (see Table 19). Most differences in the technical job performed stem mainly from the differences in aircraft model maintained. Personnel overseas worked with optical display sight systems (ODSS) and lead computing optical sight systems (LCOSS) more than did CONUS personnel. CONUS incumbents did more work than overseas personnel on Doppler antenna and electronic units. In terms of job satisfaction, both groups were comparable.

32656 B-shred Personnel. Forty-six percent of the B-shred overseas specialists were in PACAF and 36 percent were in USAFE. Almost all CONUS 32656B personnel were in TAC. As displayed in Table 21, CONUS incumbents maintained A and B model F-15s more than overseas personnel, while overseas specialists worked more with F-15C and D aircraft.

Generally, the actual technical jobs performed by the CONUS and overseas specialists did not differ very much (see Table 20). No substantial noticeable trends in tasks performed or not performed were found with an assignment overseas.

In summary, no major differences in the jobs performed were found between 32656 CONUS and overseas personnel. While some differences were found in the models of aircraft maintained, the general jobs were not substantially different.

TABLE 19

TASKS WHICH BEST DIFFERENTIATE DAFSC 32656A CONUS
AND OVERSEAS PERSONNEL
(PERCENT MEMBERS PERFORMING)

TASKS	DAFSC 32656A CONUS PERSONNEL (N=132)	DAFSC 32656A OVERSEAS PERSONNEL (N=53)	DIFFERENCE
L376 PERFORM BIT ON DOPPLER SYSTEMS	43	4	39
L377 PERFORM OPERATIONAL CHECKS OF DOPPLER SYSTEMS	45	6	39
L379 REMOVE OR INSTALL DOPPLER RADAR ELECTRONIC UNITS	45	6	39
L378 REMOVE OR INSTALL DOPPLER ANTENNA UNITS	44	6	38
L375 ISOLATE MALFUNCTIONS TO DOPPLER ANTENNA UNITS	43	6	37
L380 REMOVE OR INSTALL DOPPLER RADOMES	42	8	34
W793 REMOVE OR INSTALL EXTERNAL ECM PODS, PYLONS, OR CONTROLS	1	32	-31
K356 ISOLATE MALFUNCTIONS TO ODSS OR LCOSS LEAD AND LAUNCH COMPUTING AMPLIFIERS	39	73	-34
K357 ISOLATE MALFUNCTIONS TO ODSS OR LCOSS OPTICAL DISPLAY SIGHTS	50	85	-35
Y840 REMOVE OR INSTALL AIRCRAFT PODS	2	58	-56

TABLE 20

TASKS WHICH BEST DIFFERENTIATE DAFSC 32656B CONUS AND OVERSEAS PERSONNEL
(PERCENT MEMBERS PERFORMING)

TASKS	DAFSC 32656B CONUS PERSONNEL (N=61)	DAFSC 32656B OVERSEAS PERSONNEL (N=22)	DIFFERENCE
J335 PERFORM MUXBUS INTEGRATION CHECKS	75	45	30
G237 ISOLATE MALFUNCTIONS TO ARS ELECTRICAL SYNCHRONIZERS	30	9	21
G236 ISOLATE MALFUNCTIONS TO ARS DIGITAL DOPPLER PROCESSING UNITS	38	18	20
G240 ISOLATE MALFUNCTIONS TO ARS MODULATOR-RECEIVER- TRANSMITTERS	31	14	17
H835 PERFORM SINGLE-POINT AIRCRAFT REFUELING OR DEFUELING	13	32	-19
K344 BORESIGHT HEADS UP DISPLAY (HUD) SYSTEMS	49	68	-19
B29 COUNSEL PERSONNEL ON PERSONAL OR MILITARY RELATED PROBLEMS	8	27	-19
A5 DETERMINE WORK PRIORITIES	30	55	-25
E166 MAKE ENTRIES ON SERVICEABLE TAG-MATERIEL (DD FORM 1574)	15	45	-30

TABLE 21

**AIRCRAFT SYSTEMS MAINTAINED BY 32656A/B CONUS AND OVERSEAS PERSONNEL
(PERCENT MEMBERS RESPONDING)**

<u>AIRCRAFT MODEL</u>	<u>DAFSC 32656A CONUS PERSONNEL (N=132)</u>	<u>DAFSC 32656A OVERSEAS PERSONNEL (N=53)</u>	<u>DAFSC 32656B CONUS PERSONNEL (N=61)</u>	<u>DAFSC 32656B OVERSEAS PERSONNEL (N=22)</u>
F-15A	3	3	92	36
F-15B	3	3	89	36
F-15C	3	3	28	82
F-15D	1	3	25	68
F-111A	30	4	1	4
F-111D	27	8	4	4
F-111E	8	38	1	4
F-111F	7	49	0	0
EF-111A	1	0	0	0
FB-111A	23	0	1	4

ANALYSIS OF MAJOR COMMAND DIFFERENCES

Another possible dimension along which jobs performed by 326X6 respondents may vary is major command (MAJCOM). Consequently, the five major using commands of 326X6 incumbents are examined in terms of tasks performed, aircraft worked on, systems maintained, background characteristics, and job satisfaction. The five commands examined include TAC, USAFE, PACAF, SAC, and ATC. In general, the overall job of maintaining attack control systems is fairly similar across all commands, with the exception of ATC which is primarily involved with training functions. The primary differentiating factor between 326X6 personnel in the five using commands are the aircraft specific systems that they maintain or do not maintain.

TAC

The majority of 326X6 personnel (301) are assigned to the Tactical Air Command (TAC). Not surprising is the fact that TAC respondents maintain attack control systems on all three aircraft types, from the F-15 and F-16 to the F-111 (see Table 22). The largest number are found in the F/FB-111 Technical Maintenance cluster (96) and the F-15 Technical Maintenance cluster (71). TAC personnel are also the primary maintainers of F-16 attack control systems. Smaller numbers are found in almost all of the other clusters or job types identified in the career ladder structure, with the exception of F/FB-111 FTD instructors and Technical School Instructors (see Table 23). In terms of tasks performed, the primary tasks vary by aircraft specific systems as outlined in earlier sections of this report.

As reflected in Table 24, 67 percent of the TAC respondents are in their first enlistment, second highest among the five commands. Average time in service is 57 months. In terms of POMO, 95 percent report working in a POMO organization. Only eight percent are females.

Job satisfaction is fairly good among TAC respondents, with 60 percent finding their job interesting and 64 percent feeling their training is well utilized. However, only 40 percent plan to reenlist (see Table 25).

USAFE

These 110 respondents comprised the second largest group among the commands. Members maintain all models of the F-15 aircraft and are the only MAJCOM group with a substantial number of individuals maintaining F-111E and F-111F aircraft. Predictably, most USAFE personnel were found in the F/FB-111 Technical Maintenance cluster and the F-15 Technical Maintenance cluster.

In terms of background characteristics, the USAFE group was the second most experienced group, averaging 89 months time in service. Fifty-three percent held an A-shredout, while an additional 14 percent held the B-shredout. Only 39 percent are in their first enlistment. Forty-two percent work under the POMO concept.

Job satisfaction of these personnel was next to the lowest in terms of job interest, with 57 percent finding the job interesting. Only PACAF, at 54 percent, was lower. Reenlistment intentions are fairly good, with 47 percent planning on reenlisting.

SAC

These 48 respondents perform the broadest job of any command group, performing an average of 106 tasks. Ninety-two percent of the group maintains attack control systems on the FB-111A aircraft and hold the A-shred. Systems uniquely maintained by SAC personnel include Doppler systems, optical display sight systems (ODSS), digital computer complex (DCC) systems, and CDS, all of them being F/FB-111 aircraft specific systems.

Of all the commands, SAC personnel are the least experienced, with 73 percent being in their first enlistment. Average time in service is 48 months and 10 percent are female.

Despite the low experience level of its 326X6 personnel, most respondents find their job interesting (see Table 25). Utilization of training is exceptionally high, with 81 percent feeling their training is used fairly well or better, again highest among all commands except ATC. The only major problem is in intent to reenlist, as only 25 percent of all SAC 326X6 personnel plan to reenlist. This may be in part a function of the high number of first-term personnel in the command. This is the lowest percentage planning to reenlist of any command and may represent a major problem in future needs for experienced personnel in SAC.

PACAF

The 24 respondents assigned to PACAF primarily maintain attack control systems on F-15C and F-15D aircraft. A very small number are involved with other F-15 models and the F-16 but these numbers are considered very insignificant. By and large, the unique systems maintained are HUD systems. In terms of job structure, most PACAF respondents grouped in the F-15 Technical Maintenance cluster.

As reflected in Table 24, 42 percent of the members are in their first enlistment and 17 percent are females. On the average, members performed 81 tasks, which is the lowest average number of tasks performed of any of the major using commands. Ninety-two percent report working under the POMO concept.

In terms of job satisfaction, only 54 percent find their job interesting, the lowest of all five commands. Sixty-three percent feel their training is being used fairly well or better. Additionally, 46 percent intend to reenlist (see Table 25).

ATC

These 46 incumbents spend 35 percent of their job time performing training duties. Most are instructors at either the resident technical school or at field training detachments (FTD). Technical tasks performed are related primarily to teaching students how to perform technical functions in the classroom. As could be expected, this major command had individuals with the highest level of experience of any major command. Most of these personnel hold a 7-skill level DAFSC. With an average number of tasks of 61, these experienced personnel reported the narrowest job of all job groups identified on the basis of the task inventory.

Predictably, these more senior incumbents indicated high job satisfaction. Individuals also felt their talents and training were well utilized and 70 percent of the group planned to reenlist.

Summary

The jobs performed by major command groups are technically similar (with the exception of ATC). The main differentiating factor is the model aircraft maintained by the majority of the major command. Distinguishing tasks tend to be those specific to a certain aircraft model maintained by that major command.

Job satisfaction is highest for ATC personnel, and lowest for PACAF incumbents; SAC has the lowest reenlistment intentions, with ATC having the highest.

TABLE 22

AIRCRAFT MODELS MAINTAINED ACCORDING TO MAJOR COMMAND
(PERCENT MEMBERS MAINTAINING)

<u>AIRCRAFT MODEL:</u>	<u>TAC</u>	<u>USAFE</u>	<u>PACAF</u>	<u>SAC</u>	<u>ATC</u>
F-15A	27	15	4	0	2
F-15B	26	15	4	0	2
F-15C	10	21	71	0	2
F-15D	9	20	67	0	2
F-16A	25	1	4	0	7
F-16B	23	0	4	0	7
F-111A	18	2	0	0	9
F-111D	17	3	0	0	7
F-111E	2	33	0	2	2
F-111F	5	33	0	4	0
EF-111A	0	0	0	0	0
FB-111A	0	1	0	92	0

TABLE 23

DISTRIBUTION OF MEMBERS OF EACH JOB GROUP WITHIN EACH MAJOR COMMAND

	<u>TAC</u>	<u>USAFE</u>	<u>PACAF</u>	<u>SAC</u>	<u>ATC</u>
F/FB-111 TECHNICAL MAINTENANCE PERSONNEL	96	57	0	38	6
F/FB-111 FTD INSTRUCTORS	0	0	0	0	8
F-111 TECHNICIAN-SUPERVISORS	2	2	0	0	1
F-15 TECHNICAL MAINTENANCE PERSONNEL	71	21	16	0	0
F-15 FTD INSTRUCTORS	1	0	0	0	6
F-16 TECHNICAL MAINTENANCE PERSONNEL	10	0	1	0	0
INTEGRATED AVIONICS ATTACK, INSTRUMENT, AND FLIGHT CONTROL SYSTEMS MAINTENANCE PERSONNEL	7	2	0	0	0
F-16 FTD INSTRUCTORS	2	0	0	0	7
ADMINISTRATIVE MANAGERS	2	2	1	0	1
SUPERVISION AND MANAGEMENT PERSONNEL	11	13	1	2	1
DUE-IN-FOR-MAINTENANCE (DIFM) MONITORS	5	0	0	0	0
QUALITY CONTROL (QC) PERSONNEL	5	3	1	1	0
DEBRIEFERS	9	0	0	0	0
TECHNICAL SCHOOL INSTRUCTORS	0	0	0	0	10

TABLE 24

BACKGROUND INFORMATION FOR MAJOR COMMANDS

	<u>TAC</u>	<u>USAFE</u>	<u>PACAF</u>	<u>SAC</u>	<u>ATC</u>
NUMBER IN GROUP	301	110	24	48	46
PERCENT OF SAMPLE	54%	20%	4%	9%	8%
PERCENT LOCATED OVERSEAS	5%	100%	100%	4%	4%
<hr/>					
<u>DAFSC DISTRIBUTION</u>					
32636	12%	6%	17%	21%	4%
32656	74%	60%	66%	67%	31%
32676	14%	34%	17%	12%	65%
<hr/>					
<u>NUMBER IN EACH SHRED</u>					
A-SHRED (F/FB-111)	106	53	1	42	12
B-SHRED (F-15)	69	14	13	0	0
C-SHRED (F-16)	69	0	1	0	3
NO SHRED INDICATED	57	43	9	6	31
<hr/>					
AVERAGE GRADE	E4	E4/E5	E4/E-5	E4	E5/E6
AVERAGE TIME IN SERVICE (MONTHS TAFMS)	57	89	76	48	150
AVERAGE TIME IN CAREER FIELD (MONTHS)	33	62	36	40	96
PERCENT IN FIRST ENLISTMENT	67%	39%	42%	73%	2%
<hr/>					
PERCENT SUPERVISING	28%	39%	46%	31%	26%
<hr/>					
AVERAGE NUMBER OF TASKS PERFORMED	101	103	81	106	61
PERCENT IN POMO ORGANIZATION	95%	42%	92%	23%	22%
PERCENT MEMBERS FEMALE	8%	9%	17%	10%	0%

TABLE 25

JOB SATISFACTION FOR MAJOR COMMAND GROUPS
(PERCENT MEMBERS RESPONDING)

	<u>TAC</u>	<u>USAF</u>	<u>PACAF</u>	<u>SAC</u>	<u>ATC</u>
<u>EXPRESSED JOB INTEREST:</u>					
DULL	17	17	25	14	2
SO-SO	21	26	21	19	13
INTERESTING	60	57	54	67	85
NOT REPORTED	2	0	0	0	0
<u>PERCEIVED UTILIZATION OF TALENTS:</u>					
LITTLE OR NOT AT ALL	37	38	50	33	15
FAIRLY WELL OR BETTER	62	60	50	67	85
NOT REPORTED	1	2	0	0	0
<u>PERCEIVED UTILIZATION OF TRAINING:</u>					
LITTLE OR NOT AT ALL	34	34	37	17	17
FAIRLY WELL OR BETTER	64	65	63	81	83
NOT REPORTED	2	1	0	2	0
<u>REENLISTMENT INTENTIONS:</u>					
PLAN TO RETIRE	3	5	4	2	11
PLAN NOT TO REENLIST	56	47	50	73	19
PLAN TO REENLIST	40	47	46	25	70
NOT REPORTED	1	1	0	0	0

ANALYSIS OF WRITE-IN COMMENTS

As in most occupational surveys, respondents are invited to write in any comments they have relative to their job. The inventory for the 326X6 career ladder was also designed to survey the 326X7 and 326X8 career ladders. Consequently, write-in comments are from personnel in any of these three ladders.

Some incumbents report working on the B-1 test project and feeling that their job was not completely covered in the job inventory. While some systems are comparable across aircraft models, not all are. The two major complaints of the B-1 personnel are that they are being misutilized or are not tested fairly for the job they perform. Here are examples of some of their write-in comments:

"Working on the B-1 test team has the disadvantage of working undermanned, so I wind up doing a 423X0's job more than my own."

"Being assigned to the B-1 test program, I am removed from most all Air Force maintenance procedures. Some of the aircraft systems are close but none are the same as any others. I do not use any Air Force forms, have no TO's, do not troubleshoot or isolate malfunctions. All maintenance is directed by a Rockwell or Boeing engineer in a step-by-step procedure. I feel I have been removed from my job that I have been trained. This also places me at a disadvantage at promotion testing."

"Being assigned to the B-1, I feel the majority of questions in this survey as well as the CDC or SKT do not pertain to my duty tasks. Some systems are similar, while others I've never seen. Most of all my job I perform now I couldn't expect to be tested on. I feel myself along with others in similar situations should be exempt from SKTs which do not pertain to duty tasks."

A number of individuals report dissatisfaction with working under the POMO concept. Personnel tend to feel they are being unfairly required to perform extra work outside their own AFSC without compensation. Typical comments from these personnel include:

"Before I submit to POMO, I will get out."

"Under the POMO concept as practiced at _____, specialists were shuffled to fill APG slots at the expense of their own upgrade training."

"POMO is no good. The present concept of training a little of everything insures poor quality maintenance."

"I believe that if we did away with POMO morale would be much higher. Reenlistment would go up and you would have better trained people in each AFSC."

"The Air Force just completely ruined my job by implementing POMO or COMO. I'm not a crew chief yet I have to do their job daily. But when it comes to testing for making rank they have a lower cut off, so it makes it easier for them to make it, which in turn makes them my supervisors."

There were several additional negative comments included about POMO. On the basis of the write-in comments, some individuals seem very unhappy with working under the POMO concept.

POMO VERSUS NON-POMO JOBS

The allegation of dissatisfaction among personnel working under the POMO concept was evaluated by contrasting tasks and job attitudes for those incumbents working under POMO to all other respondents (non-POMO). There were 364 individuals assigned to POMO units and 172 personnel in non-POMO assignments.

The tasks performed by POMO personnel were somewhat different. As might be expected, the differences which do exist are associated with differing weapons systems and missions for POMO units versus the non-POMO personnel.

There are no substantial differences in job interest and reenlistment intentions for POMO and non-POMO personnel. Only two minor differences were noted: non-POMO incumbents find their training better utilized than POMO personnel, and slightly more POMO incumbents report satisfaction with sense of accomplishment from their job than do non-POMO respondents (see Table 26). Thus, the allegation of great dissatisfaction among POMO personnel is not confirmed in terms of job attitudes. They may not like the POMO concept, but they are equally as interested in their jobs as non-POMO personnel, and both report similar plans to reenlist.

TABLE 26

JOB SATISFACTION OF POMO AND NON-POMO PERSONNEL
(PERCENT MEMBERS RESPONDING)

	POMO PERSONNEL (N=364)	NON-POMO PERSONNEL (N=172)
<u>EXPRESSED JOB INTEREST:*</u>		
DULL	16	15
SO-SO	20	22
INTERESTING	62	63
<u>PERCEIVED UTILIZATION OF TALENTS:*</u>		
LITTLE OR NOT AT ALL	37	34
FAIRLY WELL OR BETTER	62	66
<u>PERCEIVED UTILIZATION OF TRAINING:*</u>		
LITTLE OR NOT AT ALL	34	26
FAIRLY WELL OR BETTER	65	73
<u>SENSE OF ACCOMPLISHMENT:*</u>		
DISSATISFIED	33	34
NEITHER SATISFIED NOR DISSATISFIED	12	18
SATISFIED	54	48
<u>REENLISTMENT INTENTIONS:*</u>		
PLAN TO RETIRE	4	5
PLAN NOT TO REENLIST	52	51
PLAN TO REENLIST	43	44

* COLUMNS MAY NOT ADD TO 100% DUE TO NO RESPONSE

IMPLICATIONS

The 326X6 career ladder has similar technical jobs being performed by incumbents but their jobs are clearly differentiated by the type of aircraft avionics maintained. Supervisory, quality control, instructor, and some administrative jobs are not differentiated by aircraft system. These findings provide support for the present three-shred classification structure at the 3- and 5-skill levels with a common 7-skill level.

Write-in comments raised the possibility of considerable dissatisfaction among personnel working in POMO units. A review of job satisfaction indicators failed to show any major differences. This finding implies that while some individuals may be unhappy with POMO, the job interest and reenlistment intention of personnel in POMO units is about the same as for other Avionics Attack Control Systems personnel.

Specialty documents (AFR 39-1 and STSs) were reviewed in light of survey data and were found to be descriptive of the career field. This implies that no changes are required in current classification and training programs.

One small group of AFS 326X6 personnel were identified who work on the B-1 test program. Their write-in comments reflect considerable dissatisfaction, but their situation is to be expected with any developing weapons system. Their situation should be resolved as the B-1 system becomes operational and its avionics maintenance is allocated to one of the existing shredouts or to a separate new shred.

APPENDIX A
SPECIALTY JOB TYPE DESCRIPTIONS

Specialty Job Type Descriptions

Listed below are brief descriptions of the job types identified in the Integrated Avionics Attack Control Systems career ladder structure. The F/FB-111 Technical Maintenance Personnel cluster contains two job types which differentiate on the basis of the model of the F-111 which the incumbents maintain. The F-16 Technical Maintenance Personnel cluster, on the other hand, is divided into two job types on the basis of the experience of the maintenance personnel. Finally, the Supervision and Management Personnel cluster has distinguishable groups of support section as well as line supervisor-managers. For additional information, the tables in this Appendix reveal various duty, background, and job satisfaction data for all of the job types identified. Appendix B contains a listing of representative tasks for these job types.

I. F/FB-111 Technical Maintenance Personnel. Two job types are identified in this cluster: F-111D Maintenance Personnel and F/FB-111A/E/F Maintenance Personnel. Brief descriptions of each job type are presented below. For supporting data and additional information, reference Tables A1, A2, and A3. Tables B2 and B3 give representative tasks for these job types respectively.

Ia. F-111D Maintenance Personnel (GRP149). Forty-two of the 44 members of this group maintain the integrated avionics attack control systems on the F-111D model aircraft. This is the only group with a high percentage of members maintaining this aircraft model, and this is the only aircraft model maintained by a majority of the members of this group. On the average, incumbents in this group perform 154 tasks. Examples of tasks performed include:

- Isolate malfunctions to ARS electronic processors
- Operate AGE
- Isolate malfunctions to TFR antenna-receivers
- Adjust terrain following mode (TFR) antenna receivers
- Isolate malfunctions to ARS electronic processors
- Perform operational checks of TARA systems

Forty-one of the members of this group indicate assignments to Cannon AFB NM. Eighty-two percent of this group are in their first enlistment, and the average time in the service for the group is 44 months. As could be expected from a lower experience technical group, only 20 percent of the members report supervising other personnel. Eighty-two percent of these workers hold a 5-skill level DAASC.

Job satisfaction is fairly high for this group, with 82 percent of the group finding their job interesting and 82 percent also feeling their talents and training are well utilized. However, only 46 percent of the group plan to reenlist, but this is not uncommon for a group consisting mainly of first enlistment personnel.

This group differentiates from the other group in this cluster mainly due to the differences in the F-111D model aircraft as compared to other F/FB-111 models. Table A3 provides a listing of tasks differentiating this group from the following F/FB-111A/E/F Maintenance Personnel job type. Though a lot of

- Interpret BIT results on fire control radar (FCR) systems
- Perform built-in-test (BIT) on FCR systems
- Remove or install FCR system LRUs
- Perform BIT on radar electro-optical (REO) systems
- Supervise apprentice integrated avionics attack control system specialists (AFSC32636C)
- Perform FCR integration checks
- Perform fire control computers (FCC) integration checks

Seventy percent of these personnel report supervising other people. The average time in service (TAFMS) for this senior group is 102 months; however, the average time in the career field (TICF) is only 36 months. This is understandable since 75 percent of the group report having cross-trained into the 326X6C career field. Fifty percent of the group indicate having cross-trained from a 321XX field and 20 percent from a 328XX career ladder. This explains the technical yet supervisory nature of the job of these individuals. Being relatively new incumbents into the field, technical tasks are still a major part of their job; however, due to their Air Force experience and higher average grade (E-5), they do a lot of supervision as well.

Job satisfaction is high for this group. Ninety percent of the group find their job interesting, and 85 percent feel their talents are well utilized. Sixty percent of the group indicate intentions to reenlist.

Vib. F-16 Junior Technical Workers (GRP147). The 36 members of this group spend the majority of their job time maintaining the integrated avionics attack control systems on the F-16A and B model aircraft. These personnel perform an average of 86 tasks, examples of which are:

- Isolate malfunctions to FCR systems LRUs
- Interpret BIT results on FCR systems
- Perform BIT on FCR systems
- Perform BIT on REO systems
- Operate aerospace ground equipment (AGE)
- Remove or install INS system LRUs

Members of this group have an average grade of E-3 and an average time in the career ladder of 17 months. Twenty-six percent of this group reports having cross-trained into the field; however, the average time in service (TAFMS) for the group was still low at 25 months. Whereas only 20 percent of the F-16 Senior Technical Workers were in their first enlistment, 92 percent of the F-16 Junior Technical Workers are. Most members of this group are in TAC and operate under the POMO structure.

As could be expected from less experienced personnel, the F-16 Junior Technical Workers find their job less satisfying than do the F-16 Senior Technical Workers. Only 55 percent of this group perceive their talents as being well utilized, and only 42 percent of the group indicate intentions to reenlist.

job time is not as high as that of Maintenance Personnel have much higher performance in the more complex supporting performance of 326X7X tasks than do the other groups of Maintenance Personnel.

Ib. F/EB-111A Maintenance Personnel (GRP125). The 154 incumbents comprise the maintenance of the integrated avionics attack control systems on the F-111 and F-111A model aircraft. Typically, members do not maintain the aircraft models of the F-111; rather, they concentrate on avionics systems. However, the jobs are still similar enough across these aircraft models that they are formed one rather than a number of groups. Members perform an average of 119 tasks. Some of these tasks are:

- Remove and install the Targeting Radar (TFR) system Line
- Line Repair and Test
- Remove and install the Navigation Systems (INS) systems LRUs
- Isolate and test the INS computers
- Operate and test the AED
- Isolate and test the Inter-transmitters
- Isolate and test the Inter-communications

Sixty-five percent of the group are in their first enlistment; the average length of service is 22 months. Eighty-two percent of these individuals are in the DAPSC. A high percentage (41 percent) of these workers are on overseas assignment. Thirty-seven percent are in USAF, 25 percent in SAC and 25 percent in SAC.

Members of this group do not perform as many integrated avionics instrument and flight control systems (326X7X) tasks as do the F-111D Maintenance Personnel. They do not work with heads-up display (HUD) equipment as much as do the Maintenance Personnel; however, they do maintain lead and lag systems (LCOSS) and optical display sight system (ODS) on the aircraft maintaining the D-model F-111 aircraft.

Job satisfaction is significantly lower than the F-111D personnel stationed at the same base. Only 54 percent of these workers find their job interesting. The distribution of talents and training is somewhat improved with 63 percent of the group finding their talents and training well-utilized. This group has the lowest reenlistment intentions of any group, with only 3 percent of the individuals planning to reenlist.

Vi. F-16 Technical Support Personnel. Two job types are identified in this cluster: Technical Support Workers and F-16 Junior Technical Workers. These two job types differ primarily in the experience level of the workers. The senior job type has more experience, perform a broader job, and require a higher level of more supervision. Representative tasks for these two job types are contained in Tables B9 and B10.

Via. F-16 Senior Technical Workers (GRP146). This group of 20 incumbents maintain the integrated avionics attack control systems on the F-16A and B model aircraft. Most of their time is spent in technical areas; however, they do spend a considerable amount of time in supervisory and managerial areas. They perform an average of 136 tasks. These tasks include:

X. Supervision and Management Personnel. Identified in this cluster are two job types: the Support Section Supervisors and Managers, and the Line Supervisors and Managers. As the titles reveal, the main difference between these two job types depend on the location of the work. The Support Section Supervisors and Managers typically work apart from the flight line; whereas, the Line Supervisors and Managers usually work on the flight line and perform more technical tasks. Representative tasks for these two job types can be found in Tables B15 and B16.

Xa. Support Section Supervisors and Managers (GRP065). Six members form this group, with job titles such as support section NCOIC. These personnel supervise and manage sections apart from actual flightline maintenance sections. Almost of their job time is spent in supervisory, managerial, training, or administrative areas. On the average, these personnel perform 40 tasks. Examples of these tasks include:

- Inventory equipment, tools, or supplies
- Direct utilization of equipment, tools, or supplies
- Plan work assignments
- Prepare APRs
- Coordinate work with other sections

All members of this group indicate supervising other personnel. The average grade for personnel in this job type is between E-5 and E-6. Members reported an average time in service (TAFMS) of 127 months, but an average time in the career field (TICF) of only 29 months. Fifty percent of the group indicate having converted to the 326X6X career ladder from either the 321XX or 328XX career fields. Thirty-three percent of the group indicate assignments overseas.

Job satisfaction is low for this group, only 50 percent of the members find their job interesting, and only 17 percent feel their training is well utilized. This is understandable, given the nature of their nontechnical job. Surprisingly, with such dissatisfaction, 67 percent of the group report intentions to reenlist.

Xb. Line Supervisors and Managers (GRP057). The 18 personnel identified in this job type are mainly concerned with the supervision and management of the actual flight line maintenance job. Fourteen percent of their job time is spent in technical areas. Members performed an average of 78 tasks. Some examples are:

- Plan work assignments
- Determine work priorities
- Prepare duty rosters
- Coordinate work with other sections
- Prepare APRs
- Indorse APRs

Ninety-four percent of this group indicate preparing and indorsing APRs. In addition, 89 percent of the personnel hold 7-skill level DAFSCs, and 50 percent of them are stationed overseas in USAFE. The average time in service (TAFMS) for this group is the highest of any job type at 194 months, with the average time in the career field also the highest of any job type at 81 months.

Job satisfaction is fairly high for the group, with 72 percent of the members finding their job interesting and 81 percent feeling their talents are well utilized. Additionally, 61 percent find their training well utilized and indicate plans to reenlist.

TABLE A1

BACKGROUND INFORMATION FOR JOB TYPES

	F/FB-111 TECHNICAL MAINTENANCE PERSONNEL		F-16 TECHNICAL MAINTENANCE PERSONNEL		SUPERVISION AND MANAGEMENT PERSONNEL	
	F-111D (GRP149)	F/FB-111A/E/F MAINTENANCE PERSONNEL (GRP125)	F-16 SENIOR WORKERS (GRP146)	F-16 JUNIOR TECHNICAL WORKERS (GRP147)	SUPPORT SECTION MANAGERS (GRP065)	LINE SUPERVISORS AND MANAGERS (GRP057)
NUMBER IN GROUP	44	154	20	36	6	18
PERCENT OF SAMPLE	8%	28%	4%	6%	1%	3%
PERCENT LOCATED OVERSEAS	5%	41%	5%	0%	33%	50%
<u>DAFSC DISTRIBUTION</u>						
32636	11%	7%	0%	37%	17%	0%
32656	82%	82%	60%	63%	33%	11%
32676	7%	11%	40%	0%	50%	89%
<u>NUMBER IN EACH SHRED</u>						
A-SHRED (F/FB-111)	80%	82%	0%	0%	17%	6%
B-SHRED (F-15)	2%	0%	0%	0%	17%	0%
C-SHRED (F-16)	0%	0%	85%	100%	16%	6%
NO SHRED INDICATED	18%	18%	15%	0%	50%	86%
<u>AVERAGE GRADE</u>						
AVERAGE TIME IN SERVICE (MONTHS TAFTMS)	3.8	4.0	4.9	3.2	5.5	6.6
AVERAGE TIME IN CAREER FIELD (MONTHS)	44	52	102	25	127	194
PERCENT IN FIRST ENLISTMENT	38	46	36	17	29	81
PERCENT SUPERVISING	82%	65%	20%	92%	17%	0%
<u>PERCENT SUPERVISING</u>						
PERCENT SUPERVISING	20%	29%	70%	8%	100%	72%
<u>AVERAGE NUMBER OF TASKS PERFORMED</u>						
AVERAGE NUMBER OF TASKS PERFORMED	154	110	136	86	40	98
PERCENT IN POMO ORGANIZATION	96%	46%	95%	97%	83%	44%
PERCENT MEMBERS FEMALE	2%	7%	5%	5%	17%	0%

TABLE A2

JOB SATISFACTION INDICES FOR JOB TYPES

	F/FB-111 TECHNICAL MAINTENANCE PERSONNEL		F-16 TECHNICAL MAINTENANCE PERSONNEL		SUPERVISION AND MANAGEMENT PERSONNEL	
	F-111D MAINTENANCE PERSONNEL (N=44)	F/FB-111A/E/F MAINTENANCE PERSONNEL (N=154)	F-16 SENIOR TECHNICAL WORKERS (N=20)	F-16 JUNIOR TECHNICAL WORKERS (N=36)	SUPPORT SECTION SUPERVISORS AND MANAGERS (N=6)	LINE SUPERVISORS AND MANAGERS (N=18)
<u>EXPRESSED JOB INTEREST:</u>						
DULL	0%	21%	0%	8%	17%	17%
SO-SO	18%	25%	10%	21%	33%	11%
INTERESTING	82%	54%	90%	71%	50%	72%
NOT REPORTED	0%	0%	0%	0%	0%	0%
<u>PERCEIVED UTILIZATION OF TALENTS:</u>						
LITTLE OR NOT AT ALL	18%	37%	15%	45%	33%	11%
FAIRLY WELL OR BETTER	82%	63%	85%	55%	67%	83%
NOT REPORTED	0%	0%	0%	0%	0%	6%
<u>PERCEIVED UTILIZATION OF TRAINING:</u>						
LITTLE OR NOT AT ALL	18%	22%	25%	29%	83%	39%
FAIRLY WELL OR BETTER	82%	77%	75%	68%	17%	61%
NOT REPORTED	0%	1%	0%	5%	0%	0%
<u>REENLISTMENT INTENTIONS:</u>						
PLAN TO RETIRE	2%	1%	5%	0%	17%	39%
PLAN NOT TO REENLIST	50%	66%	35%	58%	16%	0%
PLAN TO REENLIST	46%	33%	60%	42%	67%	61%
NOT REPORTED	2%	0%	0%	0%	0%	0%

TABLE A3

TASKS DIFFERENTIATING F-111D FROM F/FB-111A/E/F MAINTENANCE PERSONNEL
(PERCENT MEMBERS PERFORMING)

<u>TASK</u>	<u>F-111D MAINTENANCE PERSONNEL</u>	<u>F/FB-111A/F MAINTENANCE PERSONNEL</u>
ISOLATE MALFUNCTIONS TO ARS ELECTRONIC PROCESSORS	100	9
PERFORM OPERATIONAL CHECKS OF HUD SYSTEMS	91	0
ISOLATE MALFUNCTIONS TO HSD INDICATORS*	91	1
ISOLATE MALFUNCTIONS TO HSD PROCESSORS*	91	1
REMOVE OR INSTALL VDS OR MICP LRUs	91	2
REMOVE OR INSTALL IDS SYSTEM LRUs	89	0
ISOLATE MALFUNCTIONS TO ODSS OR LCOSS OPTICAL DISPLAY SIGHTS	9	92
PERFORM OPERATIONAL CHECKS OF ODSS OR LCOSS SYSTEMS	9	92
ISOLATE MALFUNCTIONS TO ARS RADAR RECEIVERS	100	18
REMOVE OR INSTALL ODSS OR LCOSS SYSTEM LRUs	9	90
PERFORM BIT ON VSD OR MICP SYSTEMS	86	2
REMOVE OR INSTALL HSD INDICATORS*	91	2

* 326X7X INTEGRATED AVIONICS FLIGHT CONTROL SYSTEMS MAINTENANCE TASKS

APPENDIX B
REPRESENTATIVE TASKS PERFORMED BY SPECIALTY JOB GROUPS

TABLE B1

REPRESENTATIVE TASKS PERFORMED BY F/FB-111 TECHNICAL
MAINTENANCE PERSONNEL (GRP099)

TASKS	PERCENT MEMBERS PERFORMING (N=200)
H284 ISOLATE MALFUNCTIONS TO TFR COMPUTERS	100
H283 ISOLATE MALFUNCTIONS TO TFR ANTENNA-RECEIVERS	100
I301 ISOLATE MALFUNCTIONS TO INS INERTIAL REFERENCE UNITS OR STABILIZED PLATFORMS	100
H289 ISOLATE MALFUNCTIONS TO TFR SYNCHRONIZER-TRANSMITTERS	100
H282 ISOLATE MALFUNCTIONS TO TFR AMPLIFIER-POWER SUPPLIES	100
H285 ISOLATE MALFUNCTIONS TO TFR ELECTRICAL EQUIPMENT RACKS	100
H287 ISOLATE MALFUNCTIONS TO TFR LOW ALTITUDE MONITORS (LAM)	100
I304 REMOVE OR INSTALL INS SYSTEM LRUs	99
G235 ISOLATE MALFUNCTIONS TO ARS ANTENNAS	99
H288 ISOLATE MALFUNCTIONS TO TFR RADAR CONTROLS	99
H294 REMOVE OR INSTALL TFR SYSTEM LRUs	98
M388 PERFORM OPERATIONAL CHECKS OF LARA SYSTEMS	98
M383 ISOLATE MALFUNCTIONS TO LARA RADAR ALTITUDE INDICATORS	98
G234 ISOLATE MALFUNCTIONS TO ARS ANTENNA PEDESTALS	98
F191 OPERATE AGE, SUCH AS POWER UNITS, HEATERS, COOLING UNITS, OR LIGHT CARTS	98
M389 REMOVE OR INSTALL LARA SYSTEM LRUs	98
F222 REMOVE OR INSTALL WAVE GUIDES	98
I303 ISOLATE MALFUNCTIONS TO INS NAVIGATIONAL COMPUTERS	97
M386 ISOLATE MALFUNCTIONS TO LARA RECEIVER-TRANSMITTERS	97
F187 INTERPRET AIRCRAFT INTERCONNECTING WIRING DIAGRAMS	97
F211 REMOVE OR INSTALL AVIONIC SYSTEMS MINOR HARDWARE SUCH AS SCREWS OR CONTROL KNOBS	97
F186 ADJUST AVIONIC SYSTEMS MINOR HARDWARE SUCH AS SCREWS OR CONTROL KNOBS	96
H287 ADJUST TFR FREQUENCY SPREADS	96
H286 ISOLATE MALFUNCTIONS TO TFR INDICATORS	96
M381 ISOLATE MALFUNCTIONS TO LOW ALTITUDE RADAR ALTIMETER (LARA) CALIBRATOR UNITS	96
H280 ADJUST TERRAIN FOLLOWING RADAR (TFR) ANTENNA RECEIVERS	95
G232 ISOLATE MALFUNCTIONS TO ARS ANTENNA CONTROL UNITS	95
G254 OPERATE ATTACK RADAR SYSTEMS	95
G227 ADJUST ATTACK RADAR SYSTEM (ARS) INDICATOR RECORDER CURSOR OR INTENSITIES	94
G233 ISOLATE MALFUNCTIONS TO ARS ANTENNA INDICATOR CONTROLS	94
F223 REPAIR WIRING	94
G243 ISOLATE MALFUNCTIONS TO ARS RADAR SET CONTROLS	93

TABLE B2

REPRESENTATIVE TASKS PERFORMED BY F-111D MAINTENANCE PERSONNEL (GRP149)

TASKS	PERCENT MEMBERS PERFORMING (N=44)
F191 OPERATE AGE, SUCH AS POWER UNITS, HEATERS, COOLING UNITS, OR LIGHT CARTS	100
H283 ISOLATE MALFUNCTIONS TO TFR ANTENNA-RECEIVERS	100
H284 ISOLATE MALFUNCTIONS TO TFR COMPUTERS	100
I301 ISOLATE MALFUNCTIONS TO INS INERTIAL REFERENCE UNITS OR STABILIZED PLATFORMS	100
G238 ISOLATE MALFUNCTIONS TO ARS ELECTRONIC PROCESSORS	100
H280 ADJUST TERRAIN FOLLOWING RADAR (TFR) ANTENNA RECEIVERS	100
G242 ISOLATE MALFUNCTIONS TO ARS RADAR RECEIVERS	100
M388 PERFORM OPERATIONAL CHECKS OF LARA SYSTEMS	100
M386 ISOLATE MALFUNCTIONS TO LARA RECEIVER-TRANSMITTERS	100
H289 ISOLATE MALFUNCTIONS TO TFR SYNCHRONIZER-TRANSMITTERS	100
H282 ISOLATE MALFUNCTIONS TO TFR AMPLIFIER-POWER SUPPLIES	100
M389 REMOVE OR INSTALL LARA SYSTEM LRUs	100
F222 REMOVE OR INSTALL WAVE GUIDES	100
H281 ADJUST TFR FREQUENCY SPREADS	100
M383 ISOLATE MALFUNCTIONS TO LARA RADAR ALTITUDE INDICATORS	100
I299 ISOLATE MALFUNCTIONS TO INS BATTERY UNITS	100
G234 ISOLATE MALFUNCTIONS TO ARS ANTENNA PEDESTALS	100
F186 ADJUST AVIONIC SYSTEMS MINOR HARDWARE SUCH AS SCREWS OR CONTROL KNOBS	100
H287 ISOLATE MALFUNCTIONS TO TFR LOW ALTITUDE MONITORS (LAM)	100
H285 ISOLATE MALFUNCTIONS TO TFR ELECTRICAL EQUIPMENT RACKS	100
G254 OPERATE ATTACK RADAR SYSTEMS	98
I304 REMOVE OR INSTALL INS SYSTEM LRUs	98
G276 REMOVE OR INSTALL ARS SYSTEM LRUs	98
H294 REMOVE OR INSTALL TFR SYSTEM LRUs	98
G244 ISOLATE MALFUNCTIONS TO ARS RADAR TRANSMITTERS	98
I303 ISOLATE MALFUNCTIONS TO INS NAVIGATIONAL COMPUTERS	98
J321 ISOLATE MALFUNCTIONS TO DCC GENERAL NAVIGATIONAL COMPUTERS	98
L379 REMOVE OR INSTALL DOPPLER RADAR ELECTRONIC UNITS	98
G235 ISOLATE MALFUNCTIONS TO ARS ANTENNAS	98
L377 PERFORM OPERATIONAL CHECKS OF DOPPLER SYSTEMS	98
G236 ISOLATE MALFUNCTIONS TO ARS DIGITAL DOPPLER PROCESSING UNITS	98
F187 INTERPRET AIRCRAFT INTERCONNECTING WIRING DIAGRAMS	98
L375 ISOLATE MALFUNCTIONS TO DOPPLER ANTENNA UNITS	98
G256 OPERATE PRESSURIZATION TEST SETS TO CHECK ARS SYSTEMS	98

TABLE B3

REPRESENTATIVE TASKS PERFORMED BY F/FB-111A/E/F MAINTENANCE PERSONNEL (GRP125)

TASKS	PERCENT MEMBERS PERFORMING (N=154)
I304 REMOVE OR INSTALL INS SYSTEM LRUs	100
H284 ISOLATE MALFUNCTIONS TO TFR COMPUTERS	100
H283 ISOLATE MALFUNCTIONS TO TFR ANTENNA-RECEIVERS	100
I301 ISOLATE MALFUNCTIONS TO INS INERTIAL REFERENCE UNITS OR STABILIZED PLATFORMS	100
H289 ISOLATE MALFUNCTIONS TO TFR SYNCHRONIZER-TRANSMITTERS	100
H282 ISOLATE MALFUNCTIONS TO TFR AMPLIFIER-POWER SUPPLIES	100
G235 ISOLATE MALFUNCTIONS TO ARS ANTENNAS	100
H285 ISOLATE MALFUNCTIONS TO TFR ELECTRICAL EQUIPMENT RACKS	100
H287 ISOLATE MALFUNCTIONS TO TFR LOW ALTITUDE MONITORS (LAM)	100
H286 ISOLATE MALFUNCTIONS TO TFR INDICATORS	99
H288 ISOLATE MALFUNCTIONS TO TFR RADAR CONTROLS	99
H294 REMOVE OR INSTALL TFR SYSTEM LRUs	99
G237 ISOLATE MALFUNCTIONS TO ARS ELECTRICAL SYNCHRONIZERS	99
G232 ISOLATE MALFUNCTIONS TO ARS ANTENNA CONTROL UNITS	99
G239 ISOLATE MALFUNCTIONS TO ARS INDICATOR-RECORDERS	99
M388 PERFORM OPERATIONAL CHECKS OF LARA SYSTEMS	98
F222 REMOVE OR INSTALL WAVE GUIDES	98
M383 ISOLATE MALFUNCTIONS TO LARA RADAR ALTITUDE INDICATORS	98
G234 ISOLATE MALFUNCTIONS TO ARS ANTENNA PEDESTALS	98
F211 REMOVE OR INSTALL AVIONIC SYSTEMS MINOR HARDWARE SUCH AS SCREWS OR CONTROL KNOBS	98
F191 OPERATE AGE, SUCH AS POWER UNITS, HEATERS, COOLING UNITS, OR LIGHT CARTS	97
I303 ISOLATE MALFUNCTIONS TO INS NAVIGATIONAL COMPUTERS	97
G240 ISOLATE MALFUNCTIONS TO ARS MODULATOR-RECEIVER-TRANSMITTERS	97
M389 REMOVE OR INSTALL LARA SYSTEM LRUs	97
G227 ADJUST ATTACK RADAR SYSTEMS (ARS) INDICATOR RECORDER CURSOR OR INTENSITIES	97
G233 ISOLATE MALFUNCTIONS TO ARS ANTENNA INDICATOR CONTROLS	97
F187 INTERPRET AIRCRAFT INTERCONNECTING WIRING DIAGRAMS	97
M386 ISOLATE MALFUNCTIONS TO LARA RECEIVER-TRANSMITTERS	96
F186 ADJUST AVIONIC SYSTEMS MINOR HARDWARE SUCH AS SCREWS OR CONTROL KNOBS	96
G243 ISOLATE MALFUNCTIONS TO ARS RADAR SET CONTROLS	96
M381 ISOLATE MALFUNCTIONS TO LOW ALTITUDE RADAR ALTIMETER (LARA) CALIBRATOR UNITS	96
H281 ADJUST TFR FREQUENCY SPREADS	95

TABLE B4

REPRESENTATIVE TASKS PERFORMED BY F/FB-111 FIELD TRAINING DETACHMENT (FTD)
INSTRUCTORS (GRP103)

TASKS	PERCENT MEMBERS PERFORMING (N=8)
D113 DEMONSTRATE OPERATION OF EQUIPMENT	100
D102 ADMINISTER OR SCORE TESTS	100
D119 EVALUATE PROGRESS OF STUDENTS	100
F186 ADJUST AVIONIC SYSTEMS MINOR HARDWARE SUCH AS SCREWS OR CONTROL KNOBS	100
E146 MAKE ENTRIES ON JOB PROFICIENCY GUIDE CONTINUATION SHEET (AF FORM 797)	100
H280 ADJUST TERRAIN FOLLOWING RADAR (TFR) ANTENNA RECEIVERS	100
H281 ADJUST TFR FREQUENCY SPREADS	100
G232 ISOLATE MALFUNCTIONS TO ARS ANTENNA CONTROL UNITS	100
H282 ISOLATE MALFUNCTIONS TO TFR AMPLIFIER-POWER SUPPLIES	100
H292 OPERATE TFR TEST SETS	100
G233 ISOLATE MALFUNCTIONS TO ARS ANTENNA INDICATOR CONTROLS	100
G237 ISOLATE MALFUNCTIONS TO ARS ELECTRICAL SYNCHRONIZERS	100
H283 ISOLATE MALFUNCTIONS TO TFR ANTENNA-RECEIVERS	100
H284 ISOLATE MALFUNCTIONS TO TFR COMPUTERS	100
H285 ISOLATE MALFUNCTIONS TO TFR ELECTRICAL EQUIPMENT RACKS	100
H286 ISOLATE MALFUNCTIONS TO TFR INDICATORS	100
H289 ISOLATE MALFUNCTIONS TO TFR SYNCHRONIZER-TRANSMITTERS	100
G234 ISOLATE MALFUNCTIONS TO ARS ANTENNA PEDESTALS	100
G235 ISOLATE MALFUNCTIONS TO ARS ANTENNAS	100
G239 ISOLATE MALFUNCTIONS TO ARS INDICATOR-RECORDERS	100
G240 ISOLATE MALFUNCTIONS TO ARS MODULATOR-RECEIVER-TRANSMITTERS	100
G227 ADJUST ATTACK RADAR SYSTEMS (ARS) INDICATOR RECORDER CURSOR OR INTENSITIES	100
F223 REPAIR WIRING	100
F209 PRESSURE TEST WAVE GUIDE ASSEMBLIES	100
D108 CONDUCT FTD TRAINING	88
F187 INTERPRET AIRCRAFT INTERCONNECTING WIRING DIAGRAMS	88
D123 PREPARE LESSON PLANS	88
D112 DEMONSTRATE HOW TO LOCATE TECHNICAL INFORMATION	88
D130 WRITE TEST QUESTIONS	88
D111 COUNSEL INDIVIDUALS ON TRAINING PROGRESS	88
F190 ISOLATE MALFUNCTIONS TO DEFECTIVE INTERCONNECTING WIRING	88
D115 DEVELOP TRAINING AIDS	88
F211 REMOVE OR INSTALL AVIONIC SYSTEMS MINOR HARDWARE SUCH AS SCREWS OR CONTROL KNOBS	88

TABLE B5

REPRESENTATIVE TASKS PERFORMED BY F-111 TECHNICIAN SUPERVISORS (GRP100)

TASKS	PERCENT MEMBERS PERFORMING (N=6)
C70 ANALYZE CAUSES OF OPERATIONAL DISCREPANCIES	100
B32 DIRECT MAINTENANCE OR CHECKOUT OF INTEGRATED AVIONIC SYSTEMS	100
E149 MAKE ENTRIES ON MAINTENANCE DATA COLLECTION RECORD (AFTO FORM 349)	100
E151 MAKE ENTRIES ON MAINTENANCE DISCREPANCY AND WORK DOCUMENT (AFTO FORM 781A)	100
F190 ISOLATE MALFUNCTIONS TO DEFECTIVE INTERCONNECTING WIRING	100
F204 PERFORM OPERATIONAL CHECKS OF AVIONICS STATUS PANELS	100
E136 MAKE ENTRIES ON AEROSPACE VEHICLE INSPECTION (AFTO FORM 781K)	100
F189 ISOLATE MALFUNCTIONS TO AVIONICS RELAY PACKAGES OR RELAY MATRIXES	100
F191 OPERATE AGE, SUCH AS POWER UNITS, HEATERS, COOLING UNITS, OR LIGHT CARTS	100
F212 REMOVE OR INSTALL AVIONIC SYSTEM RELAY PACKAGES OR RELAY MATRIXES	100
I301 ISOLATE MALFUNCTIONS TO INS INERTIAL REFERENCE UNITS OR STABILIZED PLATFORMS	100
G234 ISOLATE MALFUNCTIONS TO ARS ANTENNA PEDESTALS	100
F209 PRESSURE TEST WAVE GUIDE ASSEMBLIES	100
F222 REMOVE OR INSTALL WAVE GUIDES	100
G232 ISOLATE MALFUNCTIONS TO ARS ANTENNA CONTROL UNITS	100
F187 INTERPRET AIRCRAFT INTERCONNECTING WIRING DIAGRAMS	100
G233 ISOLATE MALFUNCTIONS TO ARS ANTENNA INDICATOR CONTROLS	100
F193 OPERATE HUD OR ODSS OR LCSS SYSTEMS FOR ILS TIE-IN TROUBLESHOOTING	100
M388 PERFORM OPERATIONAL CHECKS OF LARA SYSTEMS	100
F214 REMOVE OR INSTALL CANNON-PLUG CONNECTORS	100
F215 REMOVE OR INSTALL COAXIAL CABLES	100
F211 REMOVE OR INSTALL AVIONIC SYSTEMS MINOR HARDWARE SUCH AS SCREWS OR CONTROL KNOBS	100
I303 ISOLATE MALFUNCTIONS TO INS NAVIGATIONAL COMPUTERS	100
I304 REMOVE OR INSTALL INS SYSTEM LRUs	100
M389 REMOVE OR INSTALL LARA SYSTEM LRUs	100
F223 REPAIR WIRING	100
M387 OPERATE LARA TEST SETS	100
F208 PLUG OR CAP ELECTRICAL OR AIR LINES	100
B46 SUPERVISE APPRENTICE INTEGRATED AVIONIC ATTACK CONTROL SYSTEM SPECIALISTS (AFSC 32636A)	83
B41 INITIATE PUNITIVE ACTIONS OR RECOGNITION FOR COMMENDABLE PERFORMANCE	83
B45 PRESENT BRIEFINGS	83
B42 INTERPRET POLICIES, DIRECTIVES, OR PROCEDURES FOR SUBORDINATES	83

TABLE B6

REPRESENTATIVE TASKS PERFORMED BY F-15 TECHNICAL MAINTENANCE PERSONNEL (GRP079)

TASKS	PERCENT MEMBERS PERFORMING (N=114)
F191 OPERATE AGE, SUCH AS POWER UNITS, HEATERS, COOLING UNITS, OR LIGHT CARTS	100
I304 REMOVE OR INSTALL INS SYSTEM LRUs	99
F222 REMOVE OR INSTALL WAVE GUIDES	98
G263 PERFORM BIT ON VSD OR MICP SYSTEMS	97
K350 ISOLATE MALFUNCTIONS TO HUD PROCESSORS OR ELECTRONIC UNITS	97
F224 RESET FAULT INDICATOR LATCHES	96
K370 REMOVE OR INSTALL HUD SYSTEM LRUs	96
G231 INTERPRET BIT RESULTS ON VSD OR MICP SYSTEMS	96
G259 PERFORM ANTENNA HYDRAULIC LEAKAGE INSPECTIONS	96
F223 REPAIR WIRING	96
F205 PERFORM SAFETY WIRING	95
J332 PERFORM BIT ON CENTRAL COMPUTERS	94
G266 PERFORM MISSILE ANTENNA OR RADOME RADIO FREQUENCY (RF) OUTPUT CHECKS	94
F214 REMOVE OR INSTALL CANNON-PLUG CONNECTORS	94
G279 REMOVE OR INSTALL VSD OR MICP LRUs	93
F187 INTERPRET AIRCRAFT INTERCONNECTING WIRING DIAGRAMS	93
F211 REMOVE OR INSTALL AVIONIC SYSTEMS MINOR HARDWARE SUCH AS SCREWS OR CONTROL KNOBS	93
K364 PERFORM OPERATIONAL CHECKS OF HUD SYSTEMS	92
F220 REMOVE OR INSTALL INSTRUMENT GLARE SHIELDS	92
F186 ADJUST AVIONIC SYSTEMS MINOR HARDWARE SUCH AS SCREWS OR CONTROL KNOBS	92
K361 PERFORM BIT ON LEAD COMPUTING GYROS	92
G228 INTERPRET BUILT-IN-TEST (BIT) RESULTS ON APG-63 RADAR SETS	91
I305 REMOVE OR INSTALL NAVIGATION CONTROL INDICATOR (NCI) DIGITAL READOUT DISPLAY LIGHTS	91
K348 ISOLATE MALFUNCTIONS TO HUD CAMERAS	91
G260 PERFORM BIT ON APG-63 RADAR SETS	90
J339 REMOVE OR INSTALL CENTRAL COMPUTERS	90
F190 ISOLATE MALFUNCTIONS TO DEFECTIVE INTERCONNECTING WIRING	90
I297 ISOLATE MALFUNCTIONS TO INERTIAL MEASUREMENT UNITS OR INERTIAL NAVIGATION UNITS	89
F226 VISUALLY INSPECT AVIONICS STATUS PANELS	89
K360 PERFORM BIT ON HUD SYSTEMS OTHER THAN GUN SIGHT CAMERAS	89
K359 PERFORM BIT ON HUD GUN SIGHT CAMERAS	89

TABLE B7

REPRESENTATIVE TASKS PERFORMED BY F-15 FTD INSTRUCTORS (GRPO91)

TASKS	PERCENT MEMBERS PERFORMING (N=7)
D112 DEMONSTRATE HOW TO LOCATE TECHNICAL INFORMATION	100
D119 EVALUATE PROGRESS OF STUDENTS	100
D113 DEMONSTRATE OPERATION OF EQUIPMENT	100
F187 INTERPRET AIRCRAFT INTERCONNECTING WIRING DIAGRAMS	100
D123 PREPARE LESSON PLANS	100
D102 ADMINISTER OR SCORE TESTS	100
J306 CONVERT COMPUTER LANGUAGE FROM OCTAL TO BINARY	100
G228 INTERPRET BUILT-IN-TEST (BIT) RESULTS ON APG-63 RADAR SETS	100
G231 INTERPRET BIT RESULTS ON VSD OR MICP SYSTEMS	100
G260 PERFORM BIT ON APG-63 RADAR SETS	100
G273 PERFORM OPERATIONAL CHECKS OF TARGET DESIGNATOR CONTROLS	100
F226 VISUALLY INSPECT AVIONICS STATUS PANELS	100
K360 PERFORM BIT ON HUD SYSTEMS OTHER THAN GUN SIGHT CAMERAS	100
K364 PERFORM OPERATIONAL CHECKS OF HUD SYSTEMS	100
J332 PERFORM BIT ON CENTRAL COMPUTERS	100
K359 PERFORM BIT ON HUD GUN SIGHT CAMERAS	100
E172 MAKE ENTRIES ON TECHNICAL ORDER SYSTEMS PUBLICATION IMPROVEMENT REPORT AND REPLY FORMS (AFTO FORM 22)	100
E151 MAKE ENTRIES ON MAINTENANCE DISCREPANCY AND WORK DOCUMENT (AFTO FORM 781A)	100
D108 CONDUCT FTD TRAINING	86
D107 CONDUCT FORMAL CLASSROOM INSTRUCTION	86
E185 UPDATE TO FILES	86
F191 OPERATE AGE, SUCH AS POWER UNITS, HEATERS, COOLING UNITS, OR LIGHT CARTS	86
D111 COUNSEL INDIVIDUALS ON TRAINING PROGRESS	86
D115 DEVELOP TRAINING AIDS	86
G263 PERFORM BIT ON VSD OR MICP SYSTEMS	86
K361 PERFORM BIT ON LEAD COMPUTING GYROS	86
K362 PERFORM HUD SYSTEM INTEGRATION CHECKS	86
J333 PERFORM DATA ENTRY TO CENTRAL COMPUTERS	86
J335 PERFORM MUXBUS INTEGRATION CHECKS	86
F224 RESET FAULT INDICATOR LATCHES	86
F203 PERFORM COCKPIT INGRESS OR EGRESS PROCEDURES	86
G253 OPERATE APG-63 RADAR SETS FOR INTEGRATION CHECKS	71
C98 REVIEW TOs	71
G270 PERFORM OPERATIONAL CHECKS OF AUTOMATIC ACQUISITION OR REJECT SWITCHES	71

TABLE B8

REPRESENTATIVE TASKS PERFORMED BY F-16 TECHNICAL MAINTENANCE PERSONNEL (GRP097)

TASKS	PERCENT MEMBERS PERFORMING (N=70)
G249 ISOLATE MALFUNCTIONS TO REO INDICATOR UNITS	100
I304 REMOVE OR INSTALL INS SYSTEM LRUs	99
G247 ISOLATE MALFUNCTIONS TO FCR SYSTEM LINE REPLACEABLE UNITS (LRU)	97
G229 INTERPRET BIT RESULTS ON FIRE CONTROL RADAR (FCR) SYSTEMS	97
G230 INTERPRET BIT RESULTS ON RADAR ELECTRO-OPTICAL (REO) SYSTEMS	97
G262 PERFORM BIT ON REO SYSTEMS	97
K370 REMOVE OR INSTALL HUD SYSTEM LRUs	97
K349 ISOLATE MALFUNCTIONS TO HUD PILOT DISPLAY UNITS	97
J334 PERFORM FCC INTEGRATION CHECKS	97
K350 ISOLATE MALFUNCTIONS TO HUD PROCESSORS OR ELECTRONIC UNITS	97
F191 OPERATE AGE, SUCH AS POWER UNITS, HEATERS, COOLING UNITS, OR LIGHT CARTS	96
G278 REMOVE OR INSTALL REO SYSTEM LRUs	96
G272 PERFORM OPERATIONAL CHECKS OF REO DISPLAY SYSTEMS	96
G265 PERFORM FCR INTEGRATION CHECKS	96
G261 PERFORM BIT ON FCR SYSTEMS	94
J323 ISOLATE MALFUNCTIONS TO FIRE CONTROL COMPUTERS (FCC)	94
J341 REMOVE OR INSTALL FCC SYSTEM LRUs	93
G250 ISOLATE MALFUNCTIONS TO REO SYMBOL GENERATOR ELECTRONIC UNITS	93
F186 ADJUST AVIONIC SYSTEMS MINOR HARDWARE SUCH AS SCREWS OR CONTROL KNOBS	93
G277 REMOVE OR INSTALL FCR SYSTEM LRUs	91
I297 ISOLATE MALFUNCTIONS TO INERTIAL MEASUREMENT UNITS OR INERTIAL NAVIGATION UNITS	91
F188 ISOLATE MALFUNCTIONS IN AVIONICS STATUS PANELS	91
K351 ISOLATE MALFUNCTIONS TO HUD RATE SENSOR UNITS	91
I299 ISOLATE MALFUNCTIONS TO INS BATTERY UNITS	91
E149 MAKE ENTRIES ON MAINTENANCE DATA COLLECTION RECORD (AFTO FORM 349)	90
K364 PERFORM OPERATIONAL CHECKS OF HUD SYSTEMS	90
G274 PERFORM REO SYSTEM INTEGRATION CHECKS	89
G248 ISOLATE MALFUNCTIONS TO FCR WAVE GUIDE ASSEMBLIES	89
F190 ISOLATE MALFUNCTIONS TO DEFECTIVE INTERCONNECTING WIRING	89

TABLE B9

REPRESENTATIVE TASKS PERFORMED BY F-16 SENIOR TECHNICAL WORKERS (GRP146)

TASKS	PERCENT MEMBERS PERFORMING (N=20)
E149 MAKE ENTRIES ON MAINTENANCE DATA COLLECTION RECORD (AFTO FORM 349)	100
G230 INTERPRET BIT RESULTS ON RADAR ELECTRO-OPTICAL (REO) SYSTEMS	100
G262 PERFORM BIT ON REO SYSTEMS	100
E164 MAKE ENTRIES ON REPARABLE ITEM PROCESSING TAG (AFTO FORM 350)	100
I304 REMOVE OR INSTALL INS SYSTEM LRUs	100
G272 PERFORM OPERATIONAL CHECKS OF REO DISPLAY SYSTEMS	100
G249 ISOLATE MALFUNCTIONS TO REO INDICATOR UNITS	100
G265 PERFORM FCR INTEGRATION CHECKS	100
K370 REMOVE OR INSTALL HUD SYSTEM LRUs	100
I297 ISOLATE MALFUNCTIONS TO INERTIAL MEASUREMENT UNITS OR INERTIAL NAVIGATION UNITS	100
G274 PERFORM REO SYSTEM INTEGRATION CHECKS	100
J334 PERFORM FCC INTEGRATION CHECKS	100
F211 REMOVE OR INSTALL AVIONIC SYSTEMS MINOR HARDWARE SUCH AS SCREWS OR CONTROL KNOBS	100
F186 ADJUST AVIONIC SYSTEMS MINOR HARDWARE SUCH AS SCREWS OR CONTROL KNOBS	100
J341 REMOVE OR INSTALL FCC SYSTEM LRUs	100
F187 INTERPRET AIRCRAFT INTERCONNECTING WIRING DIAGRAMS	100
K351 ISOLATE MALFUNCTIONS TO HUD RATE SENSGR UNITS	100
F189 ISOLATE MALFUNCTIONS TO AVIONICS RELAY PACKAGES OR RELAY MATRIXES	100
I299 ISOLATE MALFUNCTIONS TO INS BATTERY UNITS	100
K344 BORESIGHT HEADS UP DISPLAY (HUD) SYSTEMS	100
G229 INTERPRET BIT RESULTS ON FIRE CONTROL RADAR (FCR) SYSTEMS	95
G261 PERFORM BIT ON FCR SYSTEMS	95
G247 ISOLATE MALFUNCTIONS TO FCR SYSTEM LINE REPLACEABLE UNITS (LRU)	95
G277 REMOVE OR INSTALL FCR SYSTEM LRUs	95
B48 SUPERVISE APPRENTICE INTEGRATED AVIONIC ATTACK CONTROL SYSTEM SPECIALISTS (AFSC 32636C)	95
G278 REMOVE OR INSTALL REO SYSTEM LRUs	95
E151 MAKE ENTRIES ON MAINTENANCE DISCREPANCY AND WORK DOCUMENT (AFTO FORM 781A)	95
K362 PERFORM HUD SYSTEM INTEGRATION CHECKS	95

TABLE B10

REPRESENTATIVE TASKS PERFORMED BY F-16 JUNIOR TECHNICAL WORKERS (GRP147)

TASKS	PERCENT MEMBERS PERFORMING (N=38)
G247 ISOLATE MALFUNCTIONS TO FCR SYSTEM LINE REPLACEABLE UNITS (LRU)	100
G229 INTERPRET BIT RESULTS ON FIRE CONTROL RADAR (FCR) SYSTEMS	100
F191 OPERATE AGE, SUCH AS POWER UNITS, HEATERS, COOLING UNITS, OR LIGHT CARTS	100
G262 PERFORM BIT ON REO SYSTEMS	100
I304 REMOVE OR INSTALL INS SYSTEM LRUs	100
G249 ISOLATE MALFUNCTIONS TO REO INDICATOR UNITS	100
K349 ISOLATE MALFUNCTIONS TO HUD PILOT DISPLAY UNITS	100
K350 ISOLATE MALFUNCTIONS TO HUD PROCESSORS OR ELECTRONIC UNITS	100
G250 ISOLATE MALFUNCTIONS TO REO SYMBOL GENERATOR ELECTRONIC UNITS	100
G261 PERFORM BIT ON FCR SYSTEMS	97
G230 INTERPRET BIT RESULTS ON RADAR ELECTRO-OPTICAL (REO) SYSTEMS	97
G272 PERFORM OPERATIONAL CHECKS OF REO DISPLAY SYSTEMS	97
K364 PERFORM OPERATIONAL CHECKS OF HUD SYSTEMS	97
K370 REMOVE OR INSTALL HUD SYSTEM LRU'S	97
K351 ISOLATE MALFUNCTIONS TO HUD RATE SENSOR UNITS	97
F186 ADJUST AVIONIC SYSTEMS MINOR HARDWARE SUCH AS SCREWS, OR CONTROL KNOBS	97
E149 MAKE ENTRIES ON MAINTENANCE DATA COLLECTION RECORD (AFTO FORM 349)	95
G278 REMOVE OR INSTALL REO SYSTEM LRUs	95
G265 PERFORM FCR INTEGRATION CHECKS	95
J341 REMOVE OR INSTALL FCC SYSTEM LRUs	95
K362 PERFORM HUD SYSTEM INTEGRATION CHECKS	95
J334 PERFORM FCC INTEGRATION CHECKS	95
G274 PERFORM REO SYSTEM INTEGRATION CHECKS	95
I299 ISOLATE MALFUNCTIONS TO INS BATTERY UNITS	95
G277 REMOVE OR INSTALL FCR SYSTEM LRUs	92
I297 ISOLATE MALFUNCTIONS TO INERTIAL MEASUREMENT UNITS OR INERTIAL NAVIGATION UNITS	92
J323 ISOLATE MALFUNCTIONS TO FIRE CONTROL COMPUTERS (FCC)	92
G248 ISOLATE MALFUNCTIONS TO FCR WAVE GUIDE ASSEMBLIES	92
J337 PERFORM OPERATIONAL CHECKS OF FCC SYSTEMS	89
F188 ISOLATE MALFUNCTIONS IN AVIONICS STATUS PANELS	89

TABLE B11

REPRESENTATIVE TASKS PERFORMED BY INTEGRATED AVIONICS ATTACK CONTROL
SYSTEMS MAINTENANCE PERSONNEL (GRP048)

TASKS	PERCENT MEMBERS PERFORMING (N=12)
F191 OPERATE AGE, SUCH AS POWER UNITS, HEATERS, COOLING UNITS, OR LIGHT CARTS	100
F214 REMOVE OR INSTALL CANNON-PLUG CONNECTORS	100
F187 INTERPRET AIRCRAFT INTERCONNECTING WIRING DIAGRAMS	100
P464 REMOVE OR INSTALL AUTOMATIC FLIGHT CONTROL SYSTEM LRUs	100
F211 REMOVE OR INSTALL AVIONIC SYSTEMS MINOR HARDWARE SUCH AS SCREWS OR CONTROL KNOBS	100
F223 REPAIR WIRING	100
F190 ISOLATE MALFUNCTIONS TO DEFECTIVE INTERCONNECTING WIRING	100
F215 REMOVE OR INSTALL COAXIAL CABLES	100
Q499 REMOVE OR INSTALL ADC OR CADC SYSTEM LRUs	100
F208 PLUG OR CAP ELECTRICAL OR AIR LINES	100
F225 SPLICE ELECTRICAL WIRING	100
F210 REMOVE CORROSION OR FOREIGN MATTER FROM AVIONIC COMPONENTS	100
F218 REMOVE OR INSTALL ELECTRICAL SOLDERLESS CONNECTORS	100
E149 MAKE ENTRIES ON MAINTENANCE DATA COLLECTION RECORD (AFTO FORM 349)	92
F226 VISUALLY INSPECT AVIONICS STATUS PANELS	92
E164 MAKE ENTRIES ON REPARABLE ITEM PROCESSING TAG (AFTO FORM 350)	92
B43 INVENTORY EQUIPMENT, TOOLS, OR SUPPLIES	92
F186 ADJUST AVIONIC SYSTEMS MINOR HARDWARE SUCH AS SCREWS OR CONTROL KNOBS	92
Q489 PERFORM OPERATIONAL CHECKS OF ADC OR CADC SYSTEMS	92
F189 ISOLATE MALFUNCTIONS TO AVIONICS RELAY PACKAGES OR RELAY MATRIXES	92
F207 PERFORM TIME COMPLIANCE TECHNICAL ORDER (TCTO) MODIFICATIONS	92
F194 OPERATE HYDRAULIC PUMPING UNITS	92
R528 REMOVE OR INSTALL ADIs	92
Q488 PERFORM LEAK CHECKS OF PITOT-STATIC SYSTEMS	92
Q504 REMOVE OR INSTALL PITOT-STATIC PROBES	92
F212 REMOVE OR INSTALL AVIONIC SYSTEMS RELAY PACKAGES OR RELAY MATRIXES	92
R531 REMOVE OR INSTALL HSI's	92
F213 REMOVE OR INSTALL AVIONIC SYSTEMS RELAYS	92
Q505 REMOVE OR INSTALL PITOT-STATIC TUBING	92
F217 REMOVE OR INSTALL ELECTRICAL CONNECTORS BY SOLDERING	92
R532 REMOVE OR INSTALL MAGNETIC STANDBY COMPASSES	92

TABLE B12

REPRESENTATIVE TASKS PERFORMED BY F-16 FTD INSTRUCTORS (GRP073)

TASKS	PERCENT MEMBERS PERFORMING (N=9)
F191 OPERATE AGE, SUCH AS POWER UNITS, HEATERS, COOLING UNITS, OR LIGHT CARTS	100
G261 PERFORM BIT ON FCR SYSTEMS	100
G262 PERFORM BIT ON REO SYSTEMS	100
G272 PERFORM OPERATIONAL CHECKS OF REO DISPLAY SYSTEMS	100
K364 PERFORM OPERATIONAL CHECKS OF HUD SYSTEMS	100
D119 EVALUATE PROGRESS OF STUDENTS	89
D114 DEVELOP COURSE CURRICULA, PLANS OF INSTRUCTION (POI), OR SPECIALTY TRAINING STANDARDS (STS)	89
G229 INTERPRET BIT RESULTS ON FIRE CONTROL RADAR (FCR) SYSTEMS	89
F187 INTERPRET AIRCRAFT INTERCONNECTING WIRING DIAGRAMS	89
G265 PERFORM FCR INTEGRATION CHECKS	89
G274 PERFORM REO SYSTEM INTEGRATION CHECKS	89
J337 PERFORM OPERATIONAL CHECKS OF FCC SYSTEMS	89
D115 DEVELOP TRAINING AIDS	89
J334 PERFORM FCC INTEGRATION CHECKS	89
K362 PERFORM HUD SYSTEM INTEGRATION CHECKS	89
D123 PREPARE LESSON PLANS	78
D112 DEMONSTRATE HOW TO LOCATE TECHNICAL INFORMATION	78
E185 UPDATE TO FILES	78
D130 WRITE TEST QUESTIONS	78
G230 INTERPRET BIT RESULTS ON RADAR ELECTRO-OPTICAL (REO) SYSTEMS	78
F203 PERFORM COCKPIT INGRESS OR EGRESS PROCEDURES	78
D108 CONDUCT FTD TRAINING	67
B48 SUPERVISE APPRENTICE INTEGRATED AVIONIC ATTACK CONTROL SYSTEM SPECIALISTS (AFSC 32636C)	67
D120 EVALUATE TRAINING METHODS, TECHNIQUES, OR MATERIALS	67
D102 ADMINISTER OR SCORE TESTS	67
G255 OPERATE FCR FOR OPERATIONAL CHECKS OR TROUBLESHOOTING OF OTHER SYSTEMS	67
D121 MAINTAIN TRAINING RECORDS, CHARTS, OR GRAPHS	67
G277 REMOVE OR INSTALL FCR SYSTEM LRU _s	67
I304 REMOVE OR INSTALL INS SYSTEM LRU _s	67
K370 REMOVE OR INSTALL HUD SYSTEM LRU _s	67
E151 MAKE ENTRIES ON MAINTENANCE DISCREPANCY AND WORK DOCUMENT (AFTO FORM 781A)	67

TABLE B13

REPRESENTATIVE TASKS PERFORMED BY ADMINISTRATIVE MANAGERS (GRP053)

TASKS	PERCENT MEMBERS PERFORMING (N=6)
B69 WRITE CORRESPONDENCE	100
B42 INTERPRET POLICIES, DIRECTIVES, OR PROCEDURES FOR SUBORDINATES	100
E132 DESIGN LOCAL WORKSHEETS OR FORMS	100
C97 PROVIDE TECHNICAL ASSISTANCE FOR JOB RELATED PROBLEMS ENCOUNTERED BY SUBORDINATES	88
A8 DEVELOP WORK METHODS OR PROCEDURES	83
A5 DETERMINE WORK PRIORITIES	83
E146 MAKE ENTRIES ON JOB PROFICIENCY GUIDE CONTINUATION SHEET (AF FORM 797)	83
B29 COUNSEL PERSONNEL ON PERSONAL OR MILITARY RELATED PROBLEMS	83
B33 DIRECT SECTION ACTIVITIES OTHER THAN MAINTENANCE	67
E167 MAKE ENTRIES ON SIGNIFICANT HISTORICAL DATA FORMS (AFTO FORM 95)	67
C70 ANALYZE CAUSES OF OPERATIONAL DISCREPANCIES	67
C100 WRITE STAFF STUDIES OR SURVEYS, OR REPORTS	67
C71 ANALYZE WORKLOAD REQUIREMENTS	67
E177 TYPE INFORMATION ON FORMS	67
C96 PREPARE APRs	67
A3 COORDINATE WORK WITH OTHER SECTIONS	67
B30 DIRECT DEVELOPMENT OR MAINTENANCE OF STATUS BOARDS, GRAPHS, OR CHARTS	67
B41 INITIATE PUNITIVE ACTIONS OR RECOGNITION FOR COMMENDABLE PERFORMANCES	67
A7 DEVELOP RECORDS OR MAINTENANCE AND DISPOSITION FILES	67
B39 INDOCTRINATE NEWLY ASSIGNED PERSONNEL	67
E156 MAKE ENTRIES ON ON-THE-JOB TRAINING RECORD (AF FORM 623)	67
E149 MAKE ENTRIES ON MAINTENANCE DATA COLLECTION RECORD (AFTO FORM 349)	50
E173 REVIEW MAINTENANCE DATA FORMS FOR CORRECTNESS OR COMPLETENESS	50
E181 UPDATE MAINTENANCE DATA RECORDS	50
B68 SUPERVISE MILITARY PERSONNEL IN AFSCs OTHER THAN 326X6, 326X7, OR 326X8	50
B45 PRESENT BRIEFINGS	50
E178 TYPE NARRATIVE CORRESPONDENCE IN DRAFT FORM	50
E179 TYPE NARRATIVE CORRESPONDENCE IN FINAL FORM	50

TABLE B14

REPRESENTATIVE TASKS PERFORMED BY SUPERVISION AND MANAGEMENT PERSONNEL (GRP030)

TASKS	PERCENT MEMBERS PERFORMING (N=29)
B29 COUNSEL PERSONNEL ON PERSONAL OR MILITARY RELATED PROBLEMS	93
A3 COORDINATE WORK WITH OTHER SECTIONS	86
A18 PLAN WORK ASSIGNMENTS	86
A19 PREPARE DUTY ROSTERS	86
C96 PREPARE APRs	83
A1 ASSIGN PERSONNEL TO DUTY POSITIONS	83
B39 INDOCTRINATE NEWLY ASSIGNED PERSONNEL	83
B42 INTERPRET POLICIES, DIRECTIVES, OR PROCEDURES FOR SUBORDINATES	79
A5 DETERMINE WORK PRIORITIES	79
E164 MAKE ENTRIES ON REPARABLE ITEM PROCESSING TAG FORMS (AFTO FORM 350)	79
D112 DEMONSTRATE HOW TO LOCATE TECHNICAL INFORMATION	79
E146 MAKE ENTRIES ON JOB PROFICIENCY GUIDE CONTINUATION SHEET (AF FORM 797)	79
E155 MAKE ENTRIES ON ON-THE-JOB TRAINING RECORD CONTINUATION SHEET (AF FORM 623A)	79
C90 INDORSE AIRMAN PERFORMANCE REPORTS (APR)	76
A24 SCHEDULE LEAVES OR PASSES	76
D111 COUNSEL INDIVIDUALS ON TRAINING PROGRESS	72
C92 INSPECT FACILITIES OR WORK AREAS FOR CONDITION OR APPEARANCE	69
C97 PROVIDE TECHNICAL ASSISTANCE FOR JOB RELATED PROBLEMS ENCOUNTERED BY SUBORDINATES	69
A4 DETERMINE REQUIREMENTS FOR PERSONNEL, SPACE, EQUIPMENT, OR SUPPLIES	69
B33 DIRECT SECTION ACTIVITIES OTHER THAN MAINTENANCE	66
A8 DEVELOP WORK METHODS OR PROCEDURES	66
B41 INITIATE PUNITIVE ACTIONS OR RECOGNITION FOR COMMENDABLE PERFORMANCES	66
B34 DIRECT UTILIZATION OF EQUIPMENT, TOOLS, OR SUPPLIES	62
B43 INVENTORY EQUIPMENT, TOOLS, OR SUPPLIES	62
D121 MAINTAIN TRAINING RECORDS, CHARTS, OR GRAPHS	62
E149 MAKE ENTRIES ON MAINTENANCE DATA COLLECTION RECORD (AFTO FORM 349)	62
B27 CONDUCT FOLLOW-UP ACTIONS ON SUPPLY OR WORK REQUESTS	62
E156 MAKE ENTRIES ON ON-THE-JOB TRAINING RECORD (AF FORM 623)	62

TABLE B15

REPRESENTATIVE TASKS PERFORMED BY SUPPORT SECTION SUPERVISORS
AND MANAGERS (GRP065)

TASKS	PERCENT MEMBERS PERFORMING (N=6)
B43 INVENTORY EQUIPMENT, TOOLS, OR SUPPLIES	100
B29 COUNSEL PERSONNEL ON PERSONAL OR MILITARY RELATED PROBLEMS	100
A18 PLAN WORK ASSIGNMENTS	100
A3 COORDINATE WORK WITH OTHER SECTIONS	100
A14 PLAN EQUIPMENT REPLACEMENT, REPAIR, OR DISPOSAL	100
B34 DIRECT UTILIZATION OF EQUIPMENT, TOOLS, OR SUPPLIES	83
C96 PREPARE APRs	83
B42 INTERPRET POLICIES, DIRECTIVES, OR PROCEDURES FOR SUBORDINATES	83
A19 PREPARE DUTY ROSTERS	83
E146 MAKE ENTRIES ON JOB PROFICIENCY GUIDE CONTINUATION SHEET (AF FORM 797)	83
A4 DETERMINE REQUIREMENTS FOR PERSONNEL, SPACE, EQUIPMENT, OR SUPPLIES	83
D112 DEMONSTRATE HOW TO LOCATE TECHNICAL INFORMATION	83
A5 DETERMINE WORK PRIORITIES	83
E155 MAKE ENTRIES ON ON-THE-JOB TRAINING RECORD CONTINUATION SHEET (AF FORM 623A)	83
E156 MAKE ENTRIES ON ON-THE-JOB TRAINING RECORD (AF FORM 623)	83
A8 DEVELOP WORK METHODS OR PROCEDURES	83
A1 ASSIGN PERSONNEL TO DUTY POSITIONS	83
A25 SCHEDULE MAINTENANCE OR CALIBRATION OF PHEL EQUIPMENT	67
C92 INSPECT FACILITIES OR WORK AREAS FOR CONDITION OR APPEARANCE	67
B33 DIRECT SECTION ACTIVITIES OTHER THAN MAINTENANCE	67
C87 EVALUATE USE OF WORKSPACE, EQUIPMENT, OR SUPPLIES	67
B41 INITIATE PUNITIVE ACTIONS OR RECOGNITION FOR CONSIDERABLE PERFORMANCES	67
E145 MAKE ENTRIES ON ISSUE/TURN IN REQUEST (AF FORM 2005)	67
C90 ENDORSE AIRMAN PERFORMANCE REPORTS (APR)	67
E170 MAKE ENTRIES ON SUPPLY CONTROL LOG FORMS (AF FORM 2413)	67
B27 CONDUCT FOLLOW-UP ACTIONS ON SUPPLY OR WORK REQUESTS	67
E164 MAKE ENTRIES ON REPARABLE ITEM PROCESSING TAG (AFTO FORM 350)	67
D111 COUNSEL INDIVIDUALS ON TRAINING PROGRESS	67

TABLE B16

REPRESENTATIVE TASKS PERFORMED BY LINE SUPERVISORS AND MANAGERS (GRP057)

TASKS	PERCENT MEMBERS PERFORMING (N=18)
A18 PLAN WORK ASSIGNMENTS	100
B29 COUNSEL PERSONNEL ON PERSONAL OR MILITARY RELATED PROBLEMS	100
A19 PREPARE DUTY ROSTERS	94
C96 PREPARE APRs	94
C90 INDORSE AIRMAN PERFORMANCE REPORTS (APR)	94
A24 SCHEDULE LEAVES OR PASSES	94
B39 INDOCTRINATE NEWLY ASSIGNED PERSONNEL	94
A5 DETERMINE WORK PRIORITIES	89
C97 PROVIDE TECHNICAL ASSISTANCE FOR JOB RELATED PROBLEMS ENCOUNTERED BY SUBORDINATES	89
A3 COORDINATE WORK WITH OTHER SECTIONS	89
E151 MAKE ENTRIES ON MAINTENANCE DISCREPANCY AND WORK DOCUMENT (AFTO FORM 781A)	89
D112 DEMONSTRATE HOW TO LOCATE TECHNICAL INFORMATION	89
B32 DIRECT MAINTENANCE OR CHECKOUT OF INTEGRATED AVIONIC SYSTEMS	83
A1 ASSIGN PERSONNEL TO DUTY POSITIONS	83
B42 INTERPRET POLICIES, DIRECTIVES, OR PROCEDURES FOR SUBORDINATES	83
E164 MAKE ENTRIES ON REPARABLE ITEM PROCESSING TAG (AFTO FORM 350)	83
D111 COUNSEL INDIVIDUALS ON TRAINING PROGRESS	83
B59 SUPERVISE INTEGRATED AVIONIC ATTACK CONTROL SYSTEMS TECHNICIANS (AFSC 32676)	78
C71 ANALYZE WORKLOAD REQUIREMENTS	78
E149 MAKE ENTRIES ON MAINTENANCE DATA COLLECTION RECORD (AFTO FORM 349)	78
B41 INITIATE PUNITIVE ACTIONS OR RECOGNITION FOR COMMENDABLE PERFORMANCES	78
E155 MAKE ENTRIES ON ON-THE-JOB TRAINING RECORD CONTINUATION SHEET (AF FORM 623A)	78
F187 INTERPRET AIRCRAFT INTERCONNECTING WIRING DIAGRAMS	78
E173 REVIEW MAINTENANCE DATA FORMS FOR CORRECTNESS OR COMPLETENESS	72
B63 SUPERVISE INTEGRATED AVIONIC COMMUNICATIONS, NAVIGATION, AND PEN-AIDS SYSTEMS TECHNICIANS (AFSC 32678)	72

TABLE B17

REPRESENTATIVE TASKS PERFORMED BY DUE-IN-FOR-MAINTENANCE (DIFM)
MONITORS (GRP071)

TASKS	PERCENT MEMBERS PERFORMING (N=5)
E164 MAKE ENTRIES ON REPARABLE ITEM PROCESSING TAG (AFTO FORM 350)	100
E166 MAKE ENTRIES ON SERVICEABLE TAG-MATERIEL (DD FORM 1574)	100
E175 REVIEW SERVICEABLE TAG-MATERIEL FORMS (DD FORM 1574)	100
A5 DETERMINE WORK PRIORITIES	100
E170 MAKE ENTRIES ON SUPPLY CONTROL LOG FORMS (AF FORM 2413)	80
B27 CONDUCT FOLLOW-UP ACTIONS ON SUPPLY OR WORK REQUESTS	80
E145 MAKE ENTRIES ON ISSUE/TURN IN REQUEST FORMS (AF FORM 2005)	80
E149 MAKE ENTRIES ON MAINTENANCE DATA COLLECTION RECORD (AFTO FORM 349)	80
B43 INVENTORY EQUIPMENT, TOOLS, OR SUPPLIES	80
D112 DEMONSTRATE HOW TO LOCATE TECHNICAL INFORMATION	80
A3 COORDINATE WORK WITH OTHER SECTIONS	80
C97 PROVIDE TECHNICAL ASSISTANCE FOR JOB RELATED PROBLEMS ENCOUNTERED BY SUBORDINATES	60
A4 DETERMINE REQUIREMENTS FOR PERSONNEL, SPACE, EQUIPMENT, OR SUPPLIES	60
E155 MAKE ENTRIES ON ON-THE-JOB TRAINING RECORD CONTINUATION SHEET (AF FORM 623A)	60

TABLE B18

REPRESENTATIVE TASKS PERFORMED BY QUALITY CONTROL (QC) PERSONNEL (GRP045)

TASKS	PERCENT MEMBERS PERFORMING (N=10)
E165 MAKE ENTRIES ON ROUTING AND REVIEW OF QUALITY CONTROL REPORTS (AF FORM 2419)	100
C94 PERFORM SAFETY INSPECTIONS	100
E163 MAKE ENTRIES ON QUALITY CONTROL INSPECTION SUMMARY (AF FORM 2420)	90
C92 INSPECT FACILITIES OR WORK AREAS FOR CONDITION OR APPEARANCE	90
C76 EVALUATE EQUIPMENT MODIFICATIONS OR TECHNICAL ORDER (TO) CHANGES	80
C98 REVIEW TOs	80
C75 EVALUATE COMPLIANCE WITH PERFORMANCE STANDARDS	70
C93 INVESTIGATE ACCIDENTS OR INCIDENTS	70
B69 WRITE CORRESPONDENCE	70
C86 EVALUATE SUGGESTIONS	70
E172 MAKE ENTRIES ON TECHNICAL ORDER SYSTEMS PUBLICATION IMPROVEMENT REPORT AND REPLY (AFTO FORM 22)	70
E156 MAKE ENTRIES ON ON-THE-JOB TRAINING RECORD (AF FORM 623)	70
C81 EVALUATE MAINTENANCE CAPABILITIES OF SECTIONS	60
C78 EVALUATE INSPECTION REPORTS OR PROCEDURES	60
C80 EVALUATE LOCAL DIRECTIVES OR OPERATING PROCEDURES	60
F203 PERFORM COCKPIT INGRESS OR EGRESS PROCEDURES	60
C96 PREPARE APRs	60
E146 MAKE ENTRIES ON JOB PROFICIENCY GUIDE CONTINUATION SHEET (AF FORM 797)	60
E155 MAKE ENTRIES ON ON-THE-JOB TRAINING RECORD CONTINUATION SHEET (AF FORM 623A)	60
C97 PROVIDE TECHNICAL ASSISTANCE FOR JOB RELATED PROBLEMS ENCOUNTERED BY SUBORDINATES	50
E141 MAKE ENTRIES ON CATEGORY I OR II MATERIAL DEFICIENCY REPORTING FORMS	50
C70 ANALYZE CAUSES OF OPERATIONAL DISCREPANCIES	50
E151 MAKE ENTRIES ON MAINTENANCE DISCREPANCY AND WORK DOCUMENT (AFTO FORM 781A)	50

TABLE B19**REPRESENTATIVE TASKS PERFORMED BY INSPECTORS (CUMOPS)**

TASKS	PERCENT MEMBERS PERFORMING (N=9)
E151 MAKE ENTRIES ON MAINTENANCE DISCREPANCY AND WORK DOCUMENT (AFTO FORM 781A)	100
E149 MAKE ENTRIES ON MAINTENANCE DATA COLLECTION RECORD (AFTO FORM 348)	100
A7 DEVELOP RECORDS ON MAINTENANCE AND DISPOSITION FILES	56
E181 UPDATE MAINTENANCE DATA RECORDS	44
E173 REVIEW MAINTENANCE DATA FORMS FOR CORRECTNESS OR COMPLETENESS	33
E136 MAKE ENTRIES ON AEROSPACE VEHICLE INSPECTION FORMS (AFTO FORM 781K)	33
A8 DEVELOP WORK METHODS OR PROCEDURES	33
B39 INDOCTRINATE NEWLY ASSIGNED PERSONNEL	33

TABLE B20

REPRESENTATIVE TASKS PERFORMED BY TECHNICAL SCHOOL INSTRUCTORS (GRP035)

TASKS	PERCENT MEMBERS PERFORMING (N=10)
D119 EVALUATE PROGRESS OF STUDENTS	90
D123 PREPARE LESSON PLANS	90
D130 WRITE TEST QUESTIONS	90
D121 MAINTAIN TRAINING RECORDS, CHARTS, OR GRAPHS	80
D102 ADMINISTER OR SCORE TESTS	70
D111 COUNSEL INDIVIDUALS ON TRAINING PROGRESS	70
D114 DEVELOP COURSE CURRICULA, PLANS OF INSTRUCTION (POI), OR SPECIALTY TRAINING STANDARDS (STS)	70
D107 CONDUCT FORMAL CLASSROOM INSTRUCTION	60
D115 DEVELOP TRAINING AIDS	60
B29 COUNSEL PERSONNEL ON PERSONAL OR MILITARY RELATED PROBLEMS	60
D124 PROCURE TRAINING AIDS, SPACE, OR EQUIPMENT	50
D112 DEMONSTRATE HOW TO LOCATE TECHNICAL INFORMATION	50

APPENDIX C

TASKS NOT REFERENCED TO SPECIALTY TRAINING STANDARDS (STSs)

TABLE C1

MOST WIDELY PERFORMED INVENTORY TASKS NOT REFERENCED TO THE 326K6A
SPECIALTY TRAINING STANDARD (STS)

TASKS	A-SHRBD FIRST ENLISTMENT PERCENT MEMBERS PERFORMING
F187 INTERPRET AIRCRAFT INTERCONNECTING WIRING DIAGRAMS	87
F222 REMOVE OR INSTALL WAVE GUIDES	86
F223 REPAIR WIRING	82
F190 ISOLATE MALFUNCTIONS TO DEFECTIVE INTERCONNECTING WIRING	76
F215 REMOVE OR INSTALL COAXIAL CABLES	72
F189 ISOLATE MALFUNCTIONS TO AVIONICS RELAY PACKAGES OR RELAY MATRIXES	69
F212 REMOVE OR INSTALL AVIONIC SYSTEMS RELAY PACKAGES OR RELAY MATRIXES	63
F188 ISOLATE MALFUNCTIONS IN AVIONICS STATUS PANELS	60
F213 REMOVE OR INSTALL AVIONIC SYSTEMS RELAYS	58
F226 VISUALLY INSPECT AVIONICS STATUS PANELS	56
F204 PERFORM OPERATIONAL CHECKS OF AVIONICS STATUS PANELS	54
F207 PERFORM TIME COMPLIANCE TECHNICAL ORDER (TCTO) MODIFICATIONS	44
J327 ISOLATE MALFUNCTIONS TO WEAPONS RELEASE SYSTEMS	43
Y851 WALK WINGS OR TAILS DURING AIRCRAFT TOWING OPERATIONS	37
Y850 TRANSPORT TEST EQUIPMENT OR UNITS TO OR FROM FLIGHTLINE	37
Y828 LAUNCH OR RECOVER AIRCRAFT	33
F220 REMOVE OR INSTALL INSTRUMENT GLARE SHIELDS	32
J322 ISOLATE MALFUNCTIONS TO DCC OR CDS MAINTENANCE CONTROL UNITS	32
Y827 JACK OR LEVEL AIRCRAFT	30

TABLE C2

MOST WIDELY PERFORMED INVENTORY TASKS NOT REFERENCED TO THE 326X6B
SPECIALTY TRAINING STANDARD (STS)

<u>TASKS</u>	<u>B-SHRED FIRST ENLISTMENT PERCENT MEMBERS PERFORMING</u>
F222 REMOVE OR INSTALL WAVE GUIDES	87
F224 RESET FAULT INDICATOR LATCHES	87
G263 PERFORM BIT ON VSD OR MICP SYSTEMS	86
F223 REPAIR WIRING	84
G266 PERFORM MISSILE ANTENNA OR RADOME RADIO FREQUENCY (RF) OUTPUT CHECKS	84
F187 INTERPRET AIRCRAFT INTERCONNECTING WIRING DIAGRAMS	82
F220 REMOVE OR INSTALL INSTRUMENT GLARE SHIELDS	82
F215 REMOVE OR INSTALL COAXIAL CABLES	77
G270 PERFORM OPERATIONAL CHECKS OF AUTOMATIC ACQUISITION OR REJECT SWITCHES	75
F194 OPERATE HYDRAULIC PUMPING UNITS	71
F207 PERFORM TIME COMPLIANCE TECHNICAL ORDER (TCTO) MODIFICATIONS	71
Y838 POSITION OR REMOVE AIRCRAFT CHOCKS	65
Y837 POSITION NONPOWERED OR POWERED AEROSPACE-GROUND EQUIPMENT (AGE) TO AIRCRAFT	61
K355 ISOLATE MALFUNCTIONS TO LCOSS OR HUD LEAD COMPUTING GRYS	55
Y825 GROUND AIRCRAFT	53
F216 REMOVE OR INSTALL ELECTRICAL CIRCUIT BREAKERS	52
F198 OPERATE PROXIMITY SWITCH CONTROL BOXES	51
F204 PERFORM OPERATIONAL CHECKS OF AVIONICS STATUS PANELS	47
Y828 LAUNCH OR RECOVER AIRCRAFT	46

AD-A115 206

AIR FORCE OCCUPATIONAL MEASUREMENT CENTER RANDOLPH AFB TX F/6 5/9
INTEGRATED AVIONICS ATTACK CONTROL SYSTEMS CAREER LADDER AFSCS --ETC(U)
MAR 82

UNCLASSIFIED

NL

2 of 2

DTIC



END

DATE

FILED

07-82

DTIC

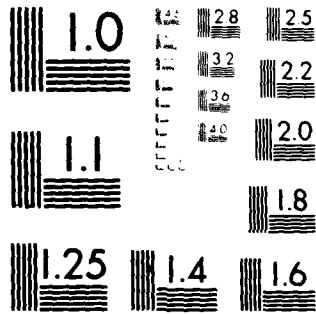

MICROCOPY RESOLUTION TEST CHART
NATIONAL BUREAU OF STANDARDS 1963-A

TABLE C3:

MOST FREQUENTLY PERFORMED INVENTORY TASKS NOT REFERENCED TO THE 32606C
SECURITY TRAINING STANDARD (STS)

TASKS	C-SERIES PERCENT MEMBERS PERFORMING
G265 PERFORM FCR INTEGRATION CHECKS	90
F188 ISOLATE MALFUNCTIONS IN AVIONICS STATUS PANELS	86
F222 REMOVE OR INSTALL WAVE GUIDES	82
G267 PERFORM OPERATIONAL CHECKS OF ANTENNA ELEVATION CONTROLS	82
F187 INTERPRET AIRCRAFT INTERCONNECTING WIRING DIAGRAMS	78
F189 ISOLATE MALFUNCTIONS TO AVIONICS RELAY PACKAGES OR RELAY MATRIXES	69
G254 OPERATE ATTACK RADAR SYSTEMS	67
F226 VISUALLY INSPECT AVIONICS STATUS PANELS	66
Y838 POSITION OR REMOVE AIRCRAFT CHOCKS	65
Y828 LAUNCH OR RECOVER AIRCRAFT	57
Y837 POSITION NONPOWERED OR POWERED AEROSPACE GROUND EQUIPMENT (AGE) TO AIRCRAFT	51
Y852 WASH AIRCRAFT	48
F213 REMOVE OR INSTALL AVIONIC SYSTEMS RELEASERS	47
Y825 GROUND AIRCRAFT	47
K358 PERFORM ATTITUDE DIRECTIONAL INDICATION (ADI) MODE SWITCH CHECKS	46
R531 REMOVE OR INSTALL HSI	46
G270 PERFORM OPERATIONAL CHECKS OF AUTOMATIC ACQUISITION OR REJECT SWITCHES	43
G235 ISOLATE MALFUNCTIONS TO ARS ANTENNAS	41
G244 ISOLATE MALFUNCTIONS TO ARS RADAR TRANSMITTERS	41
G264 PERFORM CONFIDENCE CHECKS ON FCR ANTENNA MOUNTING PINS	41

**DATE
FILMED**
7-8