

1.0

2.5

2.2

1.1

2.0

1.8

1.25

1.4

1.6

Resolution Test Chart

AD A 115384



DTIC
SELECTE
JUN 10 1982
S H D

DISTRIBUTION STATEMENT A

Approved for public release;
Distribution Unlimited

12

ESTIMATES OF YVETTE MEASUREMENT ERROR

SAI-82-497-WA

DTIC
ELECTE
JUN 1 0 1982
S D
H

N60014-81-C-0075
April 1982



ATLANTA • ANN ARBOR • BOSTON • CHICAGO • CLEVELAND • DENVER • HUNTSVILLE • LA JOLLA
LITTLE ROCK • LOS ANGELES • SAN FRANCISCO • SANTA BARBARA • TUCSON • WASHINGTON

DISTRIBUTION STATEMENT A
Approved for public release;
Distribution Unlimited

ESTIMATES OF YVETTE MEASUREMENT ERROR

SAI-82-497-WA,
OPD TR-81-201-07

April 1982

Prepared by:

F. C. Newman
E. J. Molinelli
S. L. Patterson

Ocean Physics Division

Prepared for:

Dr. E. M. Stanley
Naval Ocean Research and Development Activity
(NORDA Code 540)
Ocean Measurements Program
NSTL Station
Bay St. Louis, MS 39529

Contract No. N00014-81-C-0075

SCIENCE APPLICATIONS, INC.

1710 Goodridge Drive
P.O. Box 1303
McLean, Virginia 22102
(703) 821-4300



Science Applications, Inc.

TABLE OF CONTENTS

<u>Section</u>	<u>Page</u>
ABSTRACT.....	vi
1 INTRODUCTION.....	1-1
1.1 Background and Objectives.....	1-1
1.2 Minimum Vertical Scale of YVETTE Conductivity Data.....	1-2
1.3 Error in YVETTE Data.....	1-3
1.4 Overview.....	1-4
2 THE EFFECTS OF MEASUREMENT ERROR IN CONDUCTIVITY, TEMPERATURE, AND PRESSURE.....	2-1
2.1 The Calculation of Error in N^2	2-1
2.2 System Noise in YVETTE CTD Data.....	2-5
2.3 Error in YVETTE Data Provided to SAI.....	2-12
3 THE EFFECTS OF MEASUREMENT ERROR IN HORIZONTAL VELOCITY.....	3-1
3.1 Error Associated with the Velocity Sensor.....	3-1
3.2 Error Induced by Interactions Between YVETTE and the Environment.....	3-5
3.3 Estimates of Error in S^2	3-10
4 SUMMARY AND CONCLUSIONS.....	4-1
REFERENCES.....	R-1

Accession For	
NTIS GRA&I	<input checked="" type="checkbox"/>
DTIC TAB	<input type="checkbox"/>
Unannounced	<input type="checkbox"/>
Justification	<i>Per file</i>
<i>FL-182</i>	<i>file</i>
By	
Distribution/	
Availability Codes	
Avail and/or	
Dist Special	
<i>A</i>	

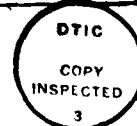

LIST OF FIGURES

<u>Figure</u>	<u>Page</u>	
2.1	The dependence on N of the relative noise in N^2 for a 16 bit system that spans the full range of T, C, and P and (a) is limited only by digitization noise or (b) has system noise levels with rms values equal to the respective values of the least significant bits. An example $N(p)$ profile is over plotted (with its pressure scale to the right) to aid the reader in determining how relative noise in N^2 varies throughout a profile. Dotted lines were added by the authors to indicate the N value at which a 2 m data point separation gives a 100% relative noise error.....	2-6
2.2	Relative error in N^2 as a function of N. Solid lines: YVETTE data after lag corrections and smoothing. Three different differencing intervals are shown. Dashed line: unsmoothed CTD data with only quantizing noise contributing.....	2-13
2.3	Same as Fig. 2.2 except that the solid lines represent the performance of data provided to SAI on digital tape. The increased noise level in N^2 is due to increased noise in the temperature data due to quantizing noise introduced when temperature values are rounded to the nearest millidegree and pressure to the nearest tenth of a decibar.....	2-15
3.1	Schematic diagram of YVETTE and a block diagram of the electronics and recording system (from Evans <u>et al.</u> , 1979).....	3-2
3.2	Vertical wavenumber spectrum for one component of the horizontal velocity vector measured by YVETTE. The peak at approximately 1 cycle per 1.7 m is due to pendulum motion of the instrument during descent. (From Evans <u>et al.</u> , 1979.).....	3-7
3.3	Logarithm of estimated relative error in S^2 versus logarithm of S^2 for vertical differencing intervals of 2, 4, 8, and 16m.....	3-14

LIST OF TABLES

<u>Table</u>		<u>Page</u>
2.1	YVETTE Sensor Specifications.....	2-7
4.1	Estimates of Noise in YVETTE Measurements.....	4-2

ABSTRACT

YVETTE is a free-fall instrument package which measures temperature, conductivity, pressure, and horizontal velocity in the upper ocean. From the direct measurements, the density, ρ , and gradient (or differenced) quantities such as Brunt-Vaisala frequency, $N = -(g/\rho)(\partial\rho/\partial z)$, and the square of the vertical shear, $S^2 = (\partial u/\partial z)^2 + (\partial v/\partial z)^2$, can be calculated. Data from YVETTE have been used to determine empirical relations between N^2 and S^2 , and variations in these relations among different oceanographic regions.

The purpose of this report is to address questions that have arisen as to the reliability of the measurements and the ensuing analyses. Sources of noise in the measurements are identified and the noise magnitudes are estimated. Estimates of noise in the calculated values of N^2 and S^2 are made based on an expression derived by Gregg (1979). Relative noise errors decrease as the quantities increase. As N^2 increases from 10^{-6} to 10^{-3} s^{-2} , the relative noise error decreases from as much as 100% to as little as 2%. Similarly, as S^2 increases over the same range of values, the relative noise error decreases from 30% to less than 1%. The apparently large noise error in N^2 (compared to that in S^2) is due to the low precision of the temperature data provided for the analyses. It is concluded that the shear characterizations, the N^2/S^2 relations, and other conclusions reached to date are not affected by the noise errors described here. Some estimates of the wavenumber limits of these analyses are also made.

Section 1
INTRODUCTION

1.1 BACKGROUND AND OBJECTIVES

The purpose of this report is to document identified sources of error in data from the free-falling density and velocity profiler YVETTE, and to assess the impact of these errors on our efforts to use YVETTE data to characterize upper ocean vertical shear. Vertical profiles of density stratification and horizontal velocity obtained with YVETTE were used to characterize the spatial distribution of small-scale shear in the upper ocean, to investigate relationships between small scale vertical shear and density stratification (Patterson, et al., 1981a) and to examine the sensitivity of Richardson number to various computational procedures (Newman, et al., 1981). A detailed description of YVETTE is presented in Evans, et al., (1979).

Specific objectives of this study were to:

- estimate the minimum vertical scale for which YVETTE conductivity data should be used in the computation of vertical density gradients,
- estimate the error in Brunt-Vaisala frequency derived from YVETTE measurements of temperature, conductivity and pressure,
- estimate the specific error in the YVETTE acoustic velocity sensor, and the overall error in computed values of shear-squared (S^2),

- assess the effects on calculated N^2 of the loss of a fourth decimal place in the original temperature data. (In the YVETTE data set supplied to SAI, temperature was reported to only three decimal places.)

1.2 MINIMUM VERTICAL SCALE OF YVETTE CONDUCTIVITY DATA

At this time an adequate description of the actual frequency response of the conductivity cell is not available, though Michael Gregg (Applied Physics Laboratory/ University of Washington) is investigating it. Discussion of this objective is therefore limited to the following.

A statement about the minimum vertical scale of YVETTE conductivity data requires a precise knowledge of the frequency response of the sensor and the fall rate of the instrument. For an ideal instrument with a flat frequency response in the pass band and a sharp roll off near the Nyquist frequency, the data are useful to the vertical scale given by the product of the fall rate and the reciprocal of the Nyquist frequency. For YVETTE the sampling frequency is 2.5 Hz, so the Nyquist frequency is 1.25 Hz. The fall rate is 20 to 25 cm s^{-1} . If the conductivity response were ideal as described above, the minimum vertical scale resolved would be 16 to 20 cm. Thus 1 m resolution would be within the capabilities of YVETTE.

De facto evidence of YVETTE's ability to resolve small scale structure in the conductivity profile exists.

Evans (personal communication) notes that after time-lag corrections are applied to the temperature profiles, small scale structure (< 2 m) observed in both the temperature and conductivity profiles yield calculated density profiles which are stable. This is not likely to be fortuitous and therefore suggests that the conductivity sensor on YVETTE is able to make valid measurements at vertical scales of 2 m.

1.3 ERROR IN YVETTE DATA

The overall error in YVETTE data depends on the error in the raw data introduced by the imperfect response of the sensor/recorder package as well as the way in which that error is modified by subsequent data transfer and processing. Some of the imperfect response can be compensated during data processing. That which cannot be compensated contributes to measurement error.

Some potential sources of error are inherent within the sensor/recorder package before it is deployed. These include zero offset or drift, calibration error, sensor inertia (i.e. time response and sensitivity), sensor precision, and least bit resolution in the digital recording system. Other sources of error are manifested while the instrument is collecting data and are the result of extraneous interactions between the package and the surrounding environment. These include disturbance of the environment by YVETTE, descent attitude problems (such as a mean tilt of the body), the horizontal accelerations imposed on the body of YVETTE by the large scale vertical shear, and pendulum-type body motions. Also, the descent rate decreases somewhat as the density of the surrounding water increases, but this has a negligible effect on measurement errors discussed in this report.

For the computation of vertical gradients over relatively small vertical scales, the important consideration is not absolute accuracy of the measured quantities, but the ability of the sensor system to resolve small scale fluctuations in the measured quantities.

Like other similar profiling devices currently in use (cf. Lambert and Patterson, 1980), the YVETTE sensor package is still under development. While the response characteristics of the individual sensors are reasonably well established, the package as a whole has undergone only limited testing. There are some aspects of the response which are not well known and can, at best, be inferred by indirect methods.

1.4 OVERVIEW

Section 2 presents an estimate of the measurement errors associated with the conductivity, temperature, and pressure sensors. It includes a discussion of the effects of various data processing techniques, and an estimate of the relative error in derived N^2 values.

Section 3 presents an estimate of the measurement error associated with the acoustic current meter, a discussion of the effects of data processing, an estimate of relative error in derived S^2 values, and a discussion of the impact of these errors on investigations utilizing YVETTE data.

A summary and conclusions are presented in Section 4.

Section 2
THE EFFECTS OF MEASUREMENT ERROR IN CONDUCTIVITY,
TEMPERATURE, AND PRESSURE

According to Gregg (1979), the two principal error types in CTD/velocity profilers are system noise and dc offsets (bias errors). System noise in the conductivity, temperature and pressure measurements introduces relative noise in the calculated value of N^2 of 0.4% to over 100% depending upon vertical spacing of the data used in the calculation. Dc offsets in conductivity, temperature and pressure introduce relatively small errors in N^2 of 0.5% to 4.5% which result from evaluating the nonlinear equation of state at incorrect values of T, C, and P.

In this section, Gregg's derivation for the effect of system noise is summarized. His equation estimating the relative noise in N^2 due to system noise is presented and applied to the YVETTE measurements. It is shown that the relative noise in N^2 from YVETTE data is large in weak stratification and becomes smaller as stratification increases.

2.1 THE CALCULATION OF ERROR IN N^2

A very precise method for calculating the Brunt Vaisala frequency (N) from data is given (e.g. Gregg, 1979) by the formula:

$$N^2 = \left(\frac{g}{\alpha}\right)^2 \frac{\Delta\alpha}{\Delta P} \quad (2.1)$$

where α = potential specific volume referred to pressure midway between two observations,

$\Delta\alpha$ = change in potential specific volume over the sample interval using as reference the pressure midway between the two observations,

ΔP = difference in pressure over the sample interval, and

g = acceleration of gravity.

Gregg uses a linearized form of the equation of state (relating α to measured values of temperature, T , conductivity, C , and pressure, P) and derives an expression for σ_N^2 , the root mean square error in N^2 due to system noise. The procedure involves taking the ensemble average of individual instances of error. If η_N^1 is the error introduced in the i th instance by an error of $\eta_{\Delta\alpha}^1$ in $\Delta\alpha$ and $\eta_{\Delta P}^1$ in ΔP , then

$$\sigma_{N^2} = \overline{(\eta_N^1)^2}^{1/2}. \quad (2.2)$$

From equation 2.1:

$$\eta_N^1 = \left(\frac{g}{\alpha}\right)^2 \frac{\overline{\Delta\alpha} + \eta_{\Delta\alpha}^1}{\Delta P + \eta_{\Delta P}^1} - N^2 \quad (2.3)$$

Gregg first defines σ_α^2 (the mean square error in α)

$$\sigma_\alpha^2 = K_T^2 \sigma_T^2 + K_C^2 \sigma_C^2 + K_P^2 \sigma_P^2, \quad (2.4)$$

where σ_α^2 = mean square error in potential specific volume.

σ_T^2 = mean square error in observed temperature.

σ_C^2 = mean square error in observed conductivity.

σ_P^2 = mean square error in observed pressure.

and

$$\begin{aligned} K_T &= \frac{\partial \alpha}{\partial T} + \frac{\partial \alpha}{\partial S} \frac{\partial S}{\partial T} \\ K_C &= \frac{\partial \alpha}{\partial S} \frac{\partial S}{\partial C} \\ K_P &= \frac{\partial \alpha}{\partial S} \frac{\partial S}{\partial P} - \Gamma \frac{\partial \alpha}{\partial T} \end{aligned} \quad (2.5)$$

where S = salinity, T=temperature, C=conductivity and P=pressure.

and Γ = adiabatic lapse rate, a function of local T, S and P.

Then, computing $\eta_{\Delta\alpha}$ and $\eta_{\Delta P}$ from η_α and η_P and substituting in equations 2.4 and 2.3 gives:

$$\begin{aligned} \sigma_{N^2} &= \frac{\sqrt{2}}{\Delta P} \left(\frac{g}{\alpha} \right)^2 \left[\sigma_\alpha^2 + \frac{(\overline{\Delta\alpha})^2}{(\overline{\Delta P})^2} \sigma_P^2 + \frac{2(\overline{\Delta\alpha})}{(\overline{\Delta P})} K_P \sigma_P^2 \right. \\ &\quad \left. + 2 \frac{\sigma_\alpha^2 \sigma_P^2}{(\overline{\Delta P})^2} + 3 \frac{K_P^2 \sigma_P^4}{(\overline{\Delta P})^2} \right]^{\frac{1}{2}} \end{aligned} \quad (2.6)$$

where $\overline{\Delta\alpha}$ = the change in potential specific volume as estimated by an ensemble average of observed changes, and

$\overline{\Delta P}$ = the change in pressure as estimated by an ensemble average of observed changes.

The last two terms in equation 2.6 are second order and, according to Gregg, can be neglected without changing estimates of σ_{N^2} by more than 10% if

$$\frac{\sqrt{2} \sigma_{\alpha}}{\overline{\Delta\alpha}} \leq 0.1 \text{ or } \frac{\sqrt{2} \sigma_P}{\overline{\Delta P}} \leq 0.1. \quad (2.7)$$

Neglecting these second order terms, dividing by N^2 to provide the relative error of N^2 and substituting the system noise contributions for the specific volume noise, Gregg derives an alternative form of the noise equation,

$$\frac{\sigma_{N^2}}{N^2} = \frac{\sqrt{2}}{\overline{\Delta P}} \left(\frac{g}{\alpha N} \right)^2 \left[K_T^2 \sigma_T^2 + K_C^2 \sigma_C^2 + \left\{ K_P + \left(\frac{\alpha N}{g} \right)^2 \right\}^2 \sigma_P^2 \right]^{\frac{1}{2}} \quad (2.8).$$

Though the coefficients K_T , K_C and K_P are each functions of T , C and P , the coefficients vary only slightly over the water column compared to variations in N . Thus Gregg (1979) approximates the variable values of the coefficients with constant values, though he does not indicate his choice. Gregg does provide figures that illustrate the dependence of K_T , K_C and K_P on T , S and P . Assuming typical ocean values of $T=10^\circ\text{C}$, $S=35^\circ/\text{oo}$ and $P=1000 \text{ dbar}=10^7 \text{ Pa}$, we select the following values for the coefficients from Gregg's figures:

$$\begin{aligned}
K_T &= 8.7 \times 10^{-7} \text{ m}^3 \text{ kg}^{-1} \text{ }^\circ\text{C}^{-1} \\
K_C &= -7.0 \times 10^{-6} \text{ m}^3 \text{ kg}^{-1} (\text{S/m})^{-1} \\
&\quad \text{or} \\
&\quad -7.0 \times 10^{-7} \text{ m}^3 \text{ kg}^{-1} (\text{mmho/cm})^{-1} \\
K_P &= 3.0 \times 10^{-14} \text{ m}^3 \text{ kg}^{-1} \text{ Pa}^{-1} \\
&\quad \text{or} \\
&\quad 3.0 \times 10^{-10} \text{ m}^3 \text{ kg}^{-1} \text{ dbar}^{-1}
\end{aligned}$$

Gregg provides plots of the relative error in N^2 as a function of N and ΔP for two assumed noise levels in CTD data, reproduced here as Figures 2.1 (a) and (b).

2.2 System Noise in YVETTE CTD Data

The raw data collected by YVETTE consists of triplets of temperature, conductivity and pressure measurements recorded at a rate of 2.5 Hz. Typical fall rates are 25 cm s⁻¹, yielding a raw data triplet every 10 cm. The datum from each measurement is recorded in a 16 bit computer word, i.e., the digital resolution is one part in 2¹⁶ over the range of the sensors. The sensor ranges and resulting parameter resolutions are indicated in Table 2.1. Also given in Table 2.1 are values of quantizing noise, YVETTE system noise, and noise in the processed data. These values are derived below.

For data with a known digital resolution the noise can be no less than a value called the quantizing noise, σ_Q . It is given by the relation:

$$\sigma_Q^2 = \frac{(\text{resolution})^2}{12} \quad (2.9)$$

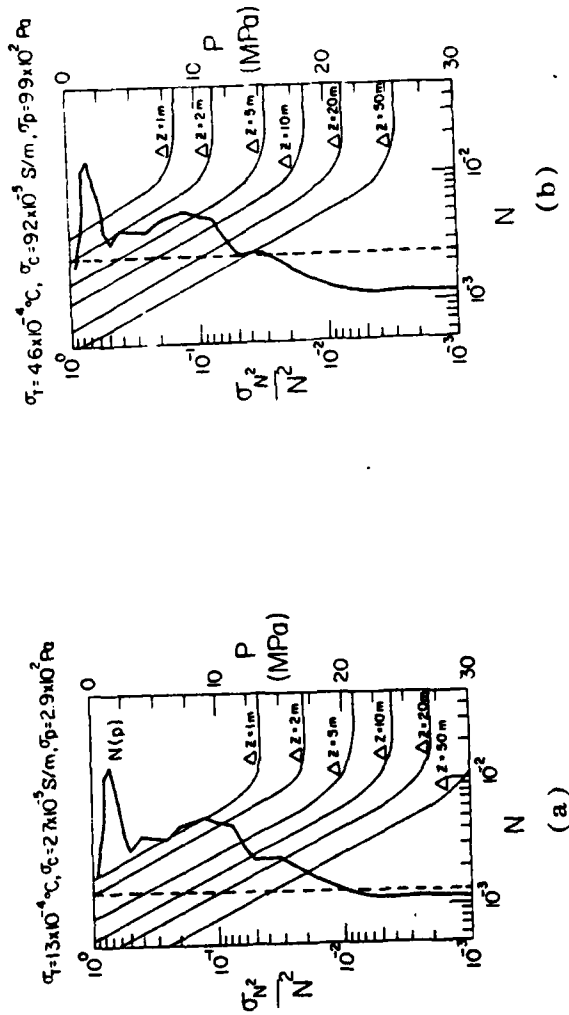

Figure 2.1 The dependence on N of the relative noise in N^2 for a 16 bit system that spans the full range of T , C , and P and (a) is limited only by digitization noise or (b) has system noise levels with rms values equal to the respective values of the least significant bits. An example $N(p)$ profile is over plotted (with its pressure scale to the right) to aid the reader in determining how relative noise in N^2 varies throughout a profile. Dotted lines were added by the authors to indicate the N value at which a 2 m data point separation gives a 100% relative noise error.

Table 2.1

YVETTE SENSOR SPECIFICATIONS

Parameter	Units	Range	Digital Resolution	Quantizing Noise σ_Q	Estimate of System Noise σ_0	Estimate of Noise in Processed Data
Temperature	°C	-3 to 32	5×10^{-4}	1.4×10^{-4}	3.1×10^{-4}	1.9×10^{-4}
Conductivity	mmho cm ⁻¹	1 to 65	1×10^{-3}	2.9×10^{-4}	2.9×10^{-4}	1.2×10^{-4}
Pressure	dbar	0 to 3200	5×10^{-2}	1.4×10^{-2}	2.9×10^{-2}	2.2×10^{-3}

Values of the quantizing noise are also given in Table 2.1.

Fofonoff et al. (1974) have performed spectral analyses of the output of similar temperature and conductivity sensors from a Brown/WHOI CTD in a homogeneous environment and state that system noise σ_0 associated with these sensors is equal to the quantizing noise σ_Q . In the case of temperature from a prototype CTD they did find system noise greater, by about a factor of $\sqrt{5}$, than the quantizing noise but they further state that the problem leading to the increased noise has been corrected. Because the CTD in YVETTE is a very early version, we will use the larger value of system noise ($\sqrt{5} \times \sigma_Q$) for temperature. For the pressure sensor we will assume, as Gregg (1979) does, that the noise is 0.029 dbar which is higher than the quantizing noise level. These system noise (σ_0) values are given in Table 2.1.

The estimated YVETTE system noise levels of Table 2.1 can not be used directly in either equation 2.6 or 2.8 because the raw YVETTE data are not used in the calculation of N^2 . The temperature data are first corrected for a time lag, then salinity is calculated and finally the T and S series are filtered and subsampled at 1 m (4 sec) intervals. A different filter is applied to the pressure series. We will assume that calculating salinity has no effect on the manner in which noise in temperature, pressure and conductivity affects noise in N^2 . That is, we will perform this error analysis as if T were time lag corrected, then T and C were filtered, then P was filtered and then N^2 was calculated from T, C and P series. It should be pointed out that filtering the data reduces the signal as well as the noise at wavenumbers above the filter cutoff wavenumber. This is an unavoidable result of filtering, but only serves

to set a high wavenumber limit on the usable data and is not considered a source of error in this discussion.

The time lag correction increases the noise to signal ratio in a manner that depends upon frequency (Fofonoff et al., 1974). A smoothing (low pass) filter decreases the noise to signal ratio in a different manner that is also frequency dependent. The frequency responses of these operations are given by their transfer functions R_1 and R_2 respectively. Assuming system noise that is originally white (i.e., frequency independent) with original rms noise $\sigma_o = 3 \times 10^{-4}$ °C (Table 2.1) the resulting noise has a spectral shape $S_R(\omega)$ given by

$$S_R(\omega) = \sigma_w^2 R_1(\omega) \cdot R_2(\omega) .$$

where σ_w is the noise per unit frequency over the band width of the measurements. The noise is assumed white, therefore σ_w is a constant. The resulting noise variance (σ_R^2) is given by

$$\sigma_R^2 = \int_0^{\infty} \sigma_w^2 R_1(\omega) \cdot R_2(\omega) d\omega .$$

That is, the change in variance is given by the ratio

$$\frac{\sigma_R^2}{\sigma_o^2} = \int_0^{\infty} R_1(\omega) \cdot R_2(\omega) d\omega . \quad (2.10)$$

The transfer function for the time lag correction, R_1 , also depends upon the number of points (m) over which a least

squares linear fit is applied in order to estimate the time derivative of temperature. According to Evans (personal communication) $m=3$ for the YVETTE temperature data. Then, according to Fofonoff et al. (1974):

$$R_1 = 1 - \frac{8}{3} \sin^2 \delta + \frac{16}{9} \sin^4 \delta + n_L^2 \sin^2 2\delta$$

where

$$\delta = \frac{\pi}{2} \frac{\omega}{\omega_Q} ,$$

ω_Q = Nyquist frequency of time series, and

n_L = time lag in number of time intervals.

Evans finds values of n_L in the range of 3.3 to 3.4 which for a sampling interval of 0.4 s (i.e., a sampling frequency of 2.5 Hz) amounts to 1.34 s. It must be pointed out that this is several times larger than the lags of ~0.16 s determined for similar instruments (e.g. by Fofonoff et al., 1974, and Joyce, 1976). Such lags were deemed necessary and reasonable in order to eliminate density inversions in the calculated density profile (Evans, personal communication).

Evans smoothed the YVETTE data with a time domain filter having a frequency response similar to the four pole Butterworth filter whose transfer function is

$$R_2 = \frac{1}{1 + (20 \delta / \pi)^8}$$

We numerically integrated the product of R_1 and R_2 over the interval $0 \leq \omega \leq \omega_Q$ ($0 \leq \delta \leq \pi/2$) and obtained for the ratio

$$\frac{\sigma_R^2}{\sigma_0^2} = 0.3865, \text{ or } \sigma_R = 0.622 \sigma_0.$$

Thus, using σ_0 for temperature from Table 2.1, the resultant rms noise in temperature is $1.9 \times 10^{-4} \text{ } ^\circ\text{C}$ in the smoothed 1 m temperature series.

The conductivity data were not lag corrected so $R_1 = 1$ for all ω and

$$\frac{\sigma_R^2}{\sigma_0^2} = 0.1612, \text{ or } \sigma_R = 0.401 \sigma_0.$$

Thus, referring to Table 2.1 the resultant rms noise in conductivity is $1.2 \times 10^{-4} \text{ mmhos cm}^{-1}$ in the smoothed 1 m conductivity series.

The pressure was smoothed by applying a 99 point filter to the time series. The weights of the filter were obtained from the Gaussian distribution for the interval $-2d$ to $+2d$, where d represents the standard deviation of the distribution. For 99 points to equal $4d$ implies that d equals 9.8 seconds, or 24.5 sampling intervals. Taking the Fourier transform of the Gaussian and squaring it gives the response function (R_3) of this filter:

$$R_3 = \frac{1}{2\pi} e^{-d^2 \omega^2}.$$

As before we integrate this over the interval $0 \leq \omega \leq \omega_0$ to obtain for pressure:

$$\frac{\sigma_R^2}{\sigma_0^2} = .0058 \text{ or } \sigma_R = .076 \sigma_0 .$$

Referring to Table 2.1, σ_0 for pressure is 2.9×10^{-2} dbar so according to the above result, the resultant noise in the processed data is 2.2×10^{-3} dbar.

The system noise estimates for the processed data are given in the final column of Table 2.1. These noise levels can then be substituted in equation 2.8. We can apply equation 2.8 if the condition of equation 2.7 is met. YVETTE meets the pressure condition if $\Delta P \geq 10 \sqrt{2} \sigma_p$, i.e., $\Delta P \geq 0.41$ dbar. So, for separations in excess of 0.41 dbar equation 2.8 can be used. The 1 m data obviously satisfy this requirement. The relative error in N^2 as a function of N and ΔP is plotted for the processed YVETTE data in Figure 2.2. For comparison a curve from Figure 2.1(a) is also plotted showing that the processed YVETTE data does not perform as well as unsmoothed CTD data with only quantizing noise. One dbar separations give errors less than 10% in N^2 only in strongly stratified regions such as the seasonal thermocline. In the less stratified main thermocline relative errors of less than 20% occur only for separations of 4 dbar or greater in N^2 . In relatively homogeneous regions like the deep ocean or mixed layers, even at 4 dbar separations, relative errors can be as large as 70%.

2.3 ERROR IN YVETTE DATA PROVIDED TO SAI

The data provided to SAI for analysis are not identical to Evans' processed YVETTE data. Temperatures were not provided to $10^{-4} \text{ } ^\circ\text{C}$ to take full advantage of the low noise level ($\sim 1.9 \times 10^{-4} \text{ } ^\circ\text{C}$) indicated in Table 2.1. Instead, the temperatures were provided to the nearest $10^{-3} \text{ } ^\circ\text{C}$ which

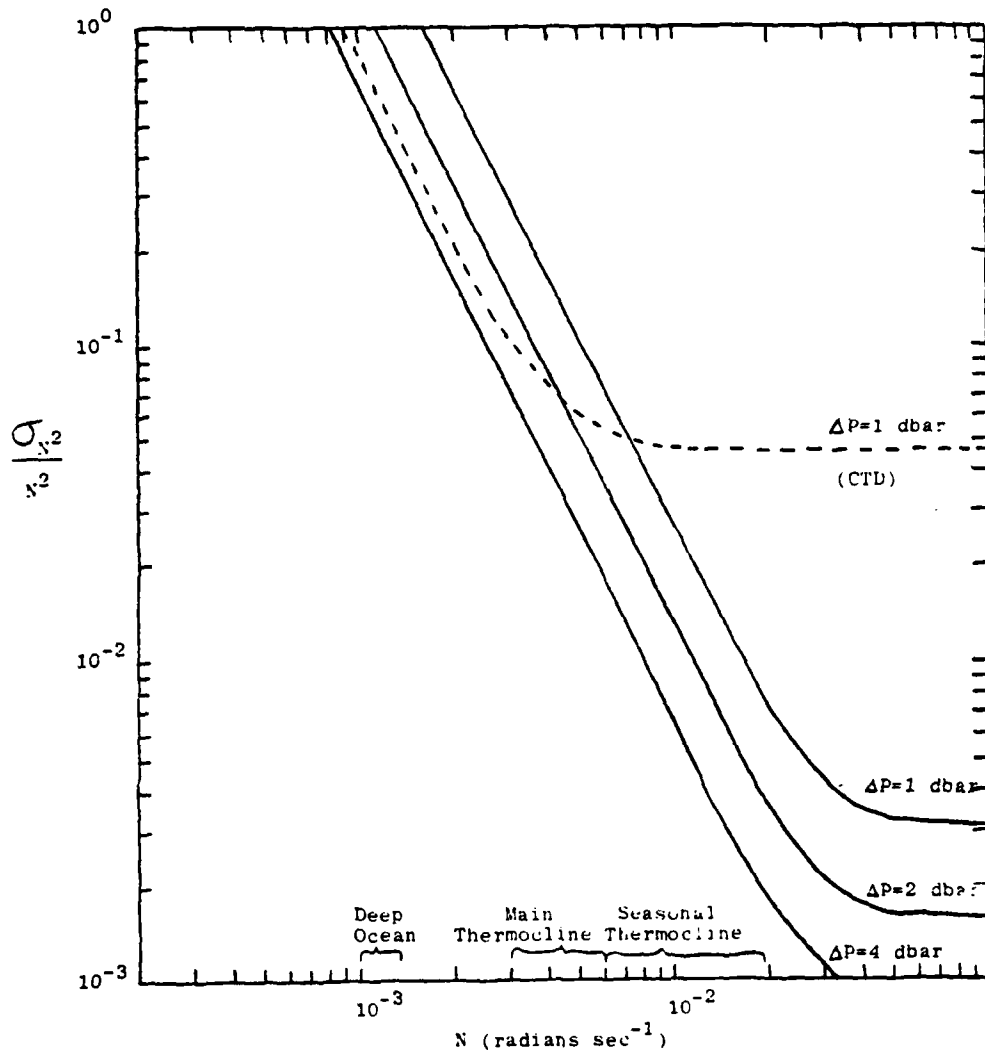

Figure 2.2 Relative error in N^2 as a function of N .

Solid lines: YVETTE data after lag corrections and smoothing. Three different differencing intervals are shown.

Dashed line: unsmoothed CTD data with only quantizing noise contributing.

increases the quantizing noise to $2.9 \times 10^{-4} \text{ } ^\circ\text{C}$. This independent source increases the total rms noise of the data.

$$\delta_{\text{TOTAL}} = \sqrt{\delta_{\text{R}}^2 + \delta_{\text{Q}}^2} = 3.5 \times 10^{-4} \text{ } ^\circ\text{C}.$$

In addition, salinity resolved to 1 ppm was provided instead of raw conductivity resolved to $.001 \text{ mmhos cm}^{-1}$. This latter substitution should not increase the noise in the calculated values of α . Pressure values were reported to the nearest 0.1 dbar which implies a quantizing noise of $.029 \text{ dbar}$. This substantially degrades the pressure series from the level that appears in Table 2.1.

Substituting the larger rms temperature and pressure noise values in equation 2.8 yields a relative error of N^2 (as a function of N and ΔP) approximately 1.6 times higher than in Figure 2.2 for $N < .01 \text{ rad s}^{-1}$ (5.5 cph) and about 10 times higher for $N > .01 \text{ rad s}^{-1}$. This case is plotted in Figure 2.3. For values of N less than $5 \times 10^{-3} \text{ rad s}^{-1}$ (3 cph), a 4 dbar spacing is required to ensure relative errors of less than 10% in N^2 . In regions of lower stratification much larger separations are required.

In conclusion, the YVETTE data collection and processing procedures do not compare favorably to optimum CTD performance except when N is large. Using more modern temperature sensor electronics will greatly improve the calculation of N^2 . It is undesirable to round temperature values to the nearest millidegree or pressure values to the nearest tenth decibar, since this step further degrades the calculation of N at all values of N .

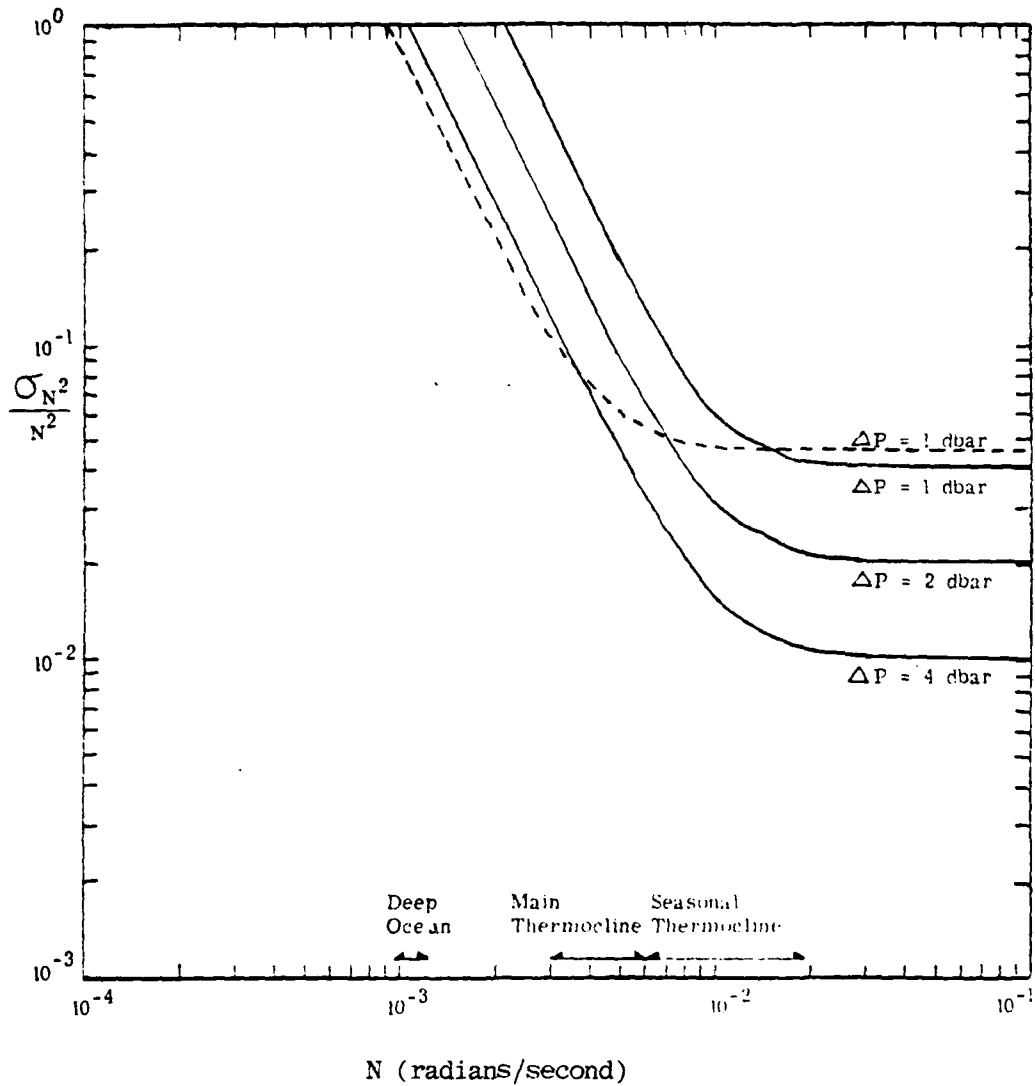

Figure 2.3 Same as Fig. 2.2 except that the solid lines represent the performance of data provided to SAI on digital tape. The increased noise level in N^2 is due to increased noise in the temperature data due to quantizing noise introduced when temperature values are rounded to the nearest millidegree, and pressure to the nearest tenth of a decibar.

Section 3

THE EFFECTS OF MEASUREMENT ERROR IN HORIZONTAL VELOCITY

3.1 ERROR ASSOCIATED WITH THE VELOCITY SENSOR

The YVETTE acoustic current meter (Figure 3.1) was developed by T. Gytre at the Christian Michelsen Institute in Bergen, Norway. It consists of two orthogonal pairs of ultrasonic (~4MHz) pingers. Each pair measures one component of horizontal water velocity relative to the body of YVETTE. For a given pair of transducers, pulses emitted simultaneously from each pinger propagate in opposite directions along the straight line path between them. The difference in travel time, Δt , is related to the component of mean velocity parallel to the propagation path by

$$\Delta t = \frac{2L\bar{V} \cos \theta}{C^2 - \bar{V}^2 \cos^2 \theta} \quad (3.1)$$

where L is the separation distance between pingers (30 cm), $\bar{V} \cos \theta$ is the component of mean water velocity parallel to the propagation path, and C is the local speed of sound. Since $\bar{V} \cos \theta$ is much less than C , equation (3.1) can be approximated by

$$\Delta t \approx \frac{2L\bar{V} \cos \theta}{C^2} \quad (3.2)$$

(Evans et al., 1979).

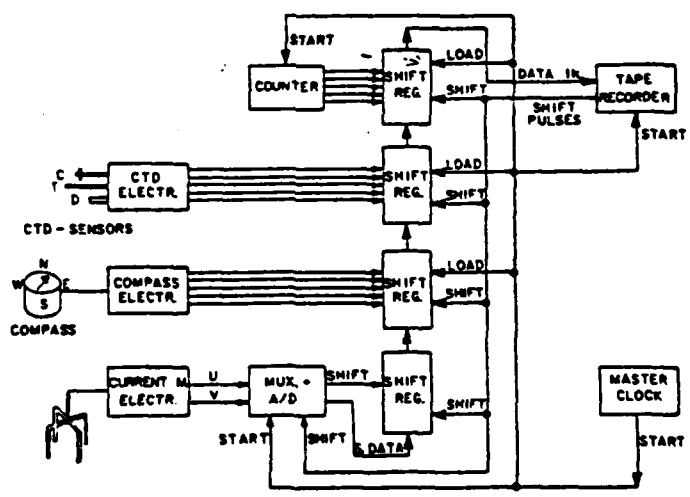
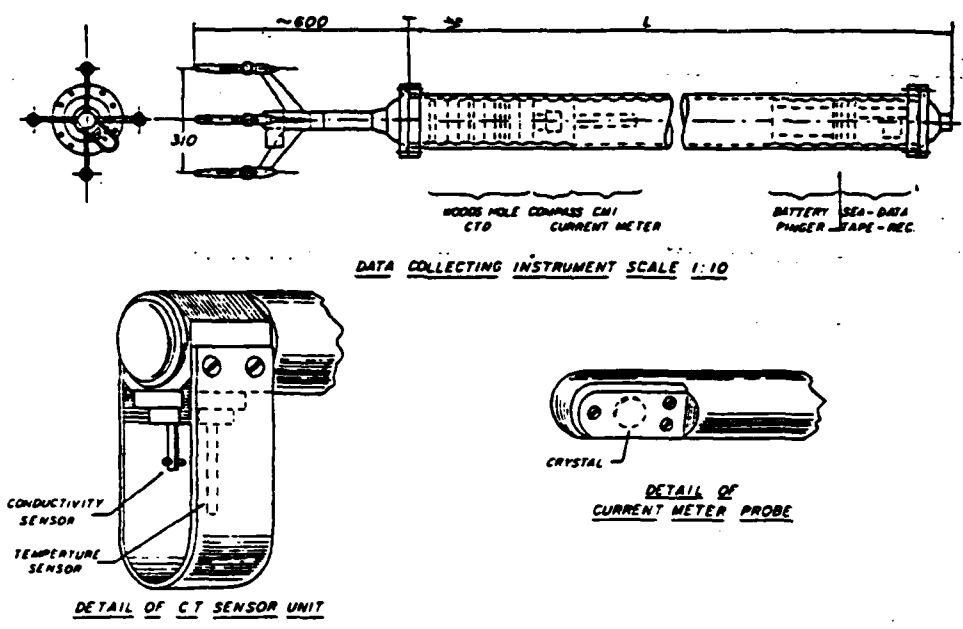

Figure 3.1 Schematic diagram of YVETTE and a block diagram of the electronics and recording system (from Evans et al., 1979).

In order to resolve current speeds as small as 1 mm s^{-1} , the noise level of the current meter should be no more than 0.5 mm s^{-1} . This requires a resolution of $\Delta \tau$ of 10^{-10} s . In order to achieve this high degree of resolution, the circuitry has been designed to continually monitor and compensate for drift in the electronic zero and for the variation with depth of the speed of sound.

The travel time differences are measured by letting the received signal from one pinger start a high speed ramp and the signal from the opposite pinger stop it. The ramp amplitude is modified by the local value of sound speed which is determined from the total travel time of the pulse between pingers. This time interval is measured by an oscillator-controlled counter which is started when the pulse is generated and stopped when the pulse is received at the opposite pinger. The least bit resolution for total travel time corresponds to a least bit resolution in sound speed of approximately 11 m s^{-1} ($\sim 0.75\%$) or a quantization noise level (i.e. (least bit) $/\sqrt{12}$) of approximately 3 m s^{-1} ($\sim 0.2\%$). From equation (3.2) this noise level in the sound speed measurement will contribute a noise of $\sim 0.4\%$ to the measured water velocities. Measured water velocities are typically of order 1 cm s^{-1} . This is because YVETTE is advected horizontally by the large scale velocity structure and that which is actually measured is the water velocity relative to the body of the instrument. In a worst case situation where a large relative velocity of say 10 cm s^{-1} is measured, the error due to the quantization noise in the sound speed determination is only 0.04 cm s^{-1} .

This and any other source of noise in the individual velocity measurements are reduced by the averaging that occurs when the data is recorded. While velocities are sampled at a rate of 30 Hz, they are digitally recorded with a least bit resolution of 0.05 cm s^{-1} at a rate of 2.5 Hz. Between recordings, travel time differences are accumulated and that which is actually recorded is an average velocity over 12 observations. Since YVETTE descends at a rate of approximately 25 cm s^{-1} , this corresponds to an average over a vertical distance of approximately 10 cm. The noise level associated with the average value is therefore smaller than that for any individual value by a factor of $1/\sqrt{12}$ and becomes $1.4 \times 10^{-2} \text{ cm s}^{-1}$.

The net noise level in the relative velocity data recorded by YVETTE is approximately 0.05 cm s^{-1} (Evans et al., 1979). This is equivalent to the least bit resolution of the digitally recorded data (Table 4.1). The absolute accuracy is not as good as this.

Calibration checks on the accuracy of YVETTE velocity measurement were attempted in a tow tank at the University of Rhode Island. The plan was to suspend YVETTE from a trolley and tow the instrument at a known constant velocity over a distance of 15 m. Unfortunately, the tow speed was variable by $\pm 10\%$ thereby necessitating a very large number of runs so that a reliable mean value could be obtained. The proportionality constant between actual and measured speed differed by 9% from the value which had been established during calibration in Norway two years earlier. However, because of potential inadequacies of the calibration facility at Rhode Island,

David Evans (personal communication) elected to use the Norwegian calibration results. Hence, the accuracy of the measured relative velocities is not known exactly, but is believed to be better than 10%.

A calibration error is a systematic error and, as such, it will modify in a linear fashion all observed velocities and thereby will modify all values of S^2 and R_i . It will not, however, affect the qualitative behavior of these parameters. In particular, it will not affect rankings of various oceanic regimes or areas with respect to levels of \bar{S}^2 or R_i (i.e. the calibration error will cause all levels to be either too high or too low). It will also not affect the correlation between N^2 and S^2 .

The orientation of the body of YVETTE with respect to the earth's magnetic field is sensed with a compass which consists of a bar magnet pivoted on fixed bearings. The angle is measured capacitively and is stored digitally with a least bit resolution of approximately 3° . Since YVETTE rotates very slowly with depth (approximately 1 rotation per 300 m), compass inertia is not believed to be a problem. The overall noise level in direction is not known, but it is probably dominated by least bit resolution (Table 4.1).

3.2 ERROR INDUCED BY INTERACTIONS BETWEEN YVETTE AND THE ENVIRONMENT

YVETTE has been designed to minimize disturbance of the environment at the point where observations are obtained. The acoustic transducers are approximately 60 cm

below the pressure case which constitutes the main body of YVETTE (Figure 3.1). The transducer pairs are separated horizontally by approximately 30 cm or about twice the diameter of the pressure case. Since the sensors are at the lower end of YVETTE, they penetrate undisturbed water well ahead of the main body.

Because YVETTE descends at a relatively slow rate ($\sim 25 \text{ cm s}^{-1}$) it experiences horizontal accelerations imposed by the local velocity field. YVETTE responds as a high-pass filter and is unable to directly resolve fluctuations in horizontal velocity over vertical scales greater than 20 m. This cutoff is established by examining vertical wavenumber spectra of velocity profiles measured with YVETTE (Figure 3.2). For wavenumbers greater than 0.05 cycles per meter (i.e. wavelengths less than 20 m) the spectrum exhibits the expected slope of -2 to -2.5. However, for wavenumbers less than 0.05 cycles per meter, where the instrument should act as a high-pass filter, the spectrum is indeed flat. Thus for wavenumbers higher than 0.05 m^{-1} , YVETTE directly measures velocity subject to the rather small errors discussed in this Section. For wavenumbers lower than 0.05 m^{-1} , an algorithm is required to reconstruct the long wavelength components of the velocity profile. David Evans has constructed such an algorithm which reconstructs the actual velocity profile in an incremental fashion by predicting the response of YVETTE to the sequence of observed relative velocities. This algorithm is described in Rubenstein, *et al.*, (1981). It has proven to be capable of reproducing to within $2\text{-}3 \text{ cm s}^{-1}$ rms the velocity structure recorded by a simultaneous Absolute Velocity Profiler (AVP) drop performed by T. Sanford. The rms velocity difference between AVP and corrected YVETTE profiles is due to the high wavenumber content of the YVETTE

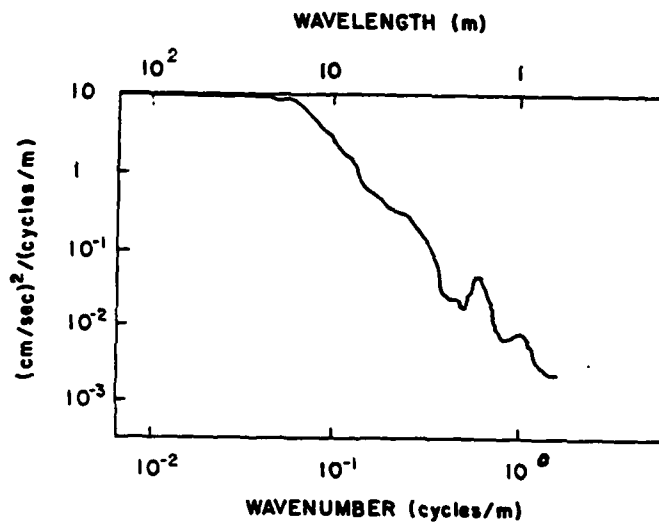

Figure 3.2 Vertical wavenumber spectrum for one component of the horizontal velocity vector measured by YVETTE. The peak at approximately 1 cycle per 1.7 m is due to pendulum motion of the instrument during descent. (From Evans *et al.*, 1979.)

profile (which is lacking in the lower resolution AVP profile), to the error at low wavenumbers in the corrected YVETTE profile, and, of course, to measurement noise in the AVP and YVETTE profiles. According to Evans (private communication, 1982), much of the rms velocity difference between the AVP and corrected YVETTE profiles is due to the high wavenumber content of the YVETTE profile. Because the error in the corrected YVETTE velocity profile is not known for the band of wavenumbers less than 0.05 m^{-1} , but is thought to be small, we assume this error to be negligible.

According to Evans et al. (1979), the expected mean value of either velocity component observed by YVETTE is zero. This is due to the fact that YVETTE tends to rotate slowly as it descends and also tends to high-pass filter the actual velocity profile to scales smaller than the rotation scale. Calculations of this mean over many segments of many profiles have shown that it tends to vary about zero by about 0.1 cm s^{-1} . The reason for this apparent drift is not clear. According to Evans (personal communication) this offset varies very slowly with depth. It therefore has a long vertical wavelength and cannot contribute significantly to the noise level in shear over small scales.

The possibility of momentary instrument tilt due to strong local shear was considered by Evans, et al. (1979). They calculate a tilt of 0.03° in response to a rather strong shear of $5 \times 10^{-2} \text{ s}^{-1}$. A tilt of this magnitude would induce a velocity error of $1.25 \times 10^{-2} \text{ s}^{-1}$ in the direction of the shear. A shear of $5 \times 10^{-2} \text{ s}^{-1}$ corresponds to a velocity difference of 10 cm s^{-1} over half the instrument length (2 meters). The relative velocity measured by YVETTE would therefore be 10 cm s^{-1} so the error due to tilt in this extreme case is of order 0.1%.

If, while descending, YVETTE were to have a mean tilt due to asymmetries in the distribution of mass within the instrument package, this would cause an apparent constant zero offset in one or both velocity components. At a descent rate of 25 cm s^{-1} the 0.1 cm s^{-1} value cited above would correspond to a mean tilt of about 0.2° . To eliminate such effects, the mean for each profile is removed from the data before other processing.

From vertical wavenumber spectra of YVETTE velocity profiles (Figure 3.2), it has been deduced that, while descending, the tube sometimes exhibits pendulum-like oscillatory motions with a period of approximately 6 seconds. This type of response is apparently common for long cylindrical tubes. In a worst case these oscillations were manifested in the velocity profile with an amplitude of 0.25 cm s^{-1} . A digital notch filter has been developed and used successfully in removing this effect from the data. In the data set used for our analyses this oscillation was removed by smoothing the data over a vertical scale of 2 m. A description of this smoothing procedure is presented in Lambert et al. (1980).

The identifiable sources of noise due to interaction of YVETTE with the environment, have been made insignificant either through instrument design or through subsequent data processing. Shear spectra show the expected rise with +2 slope at high wavenumbers only when the signal energy level drops below that associated with least bit noise of $\pm 0.05 \text{ cm s}^{-1}$ in the velocity measurements (Evans et al. 1979). It can therefore be concluded that YVETTE can resolve vertical shear over vertical scales of 2 to 20 m with a noise level which is consistent with the least bit resolution in velocity. The noise level in shear and S^2 are derived in the next section. The

absolute accuracy of shear over these small scales may have a systematic error as large as 10% due to a possible error in the calibration constant. Over larger vertical scales both precision and accuracy of the shear values are reduced because of the horizontal drag on YVETTE which can be only approximately modeled and because of the apparent zero drift which is due to unknown causes.

3.3 ESTIMATES OF ERROR IN S^2

The error in S^2 over small scales derives from the noise level of the velocity sensor and a possible systematic calibration error as discussed above. In the data set supplied to SAI, velocity was reported to 10^{-2} cm s^{-1} . Since this precision is better than the 0.05 cm s^{-1} least bit resolution, it does not contribute to error in velocity or S^2 .

The Butterworth smoothing filter that was applied to the profiles effectively removes fluctuations with vertical scales less than 2 m and reduces the noise level in the profile by a factor of 0.401 (cf. discussion on the effects of the Butterworth filter in Section 2.2). Hence the rms noise level in the filtered velocity data is

$$\sigma_u = \langle E_u^2 \rangle^{1/2} = 0.401 \times 0.05 = 2.0 \times 10^{-2} \text{ cm s}^{-1}$$

where E_u represents the noise error in one sample and the brackets denote an ensemble average over many samples. The components of vertical shear are computed by simple differences, hence

$$\frac{\partial u}{\partial z} = \frac{\Delta u}{\Delta z} = \frac{u(z + \Delta z) - u(z)}{\Delta z}$$

The noise error associated with Δu is $\sigma_u \sqrt{2}$, assuming the noise in $u(z + \Delta z)$ to be uncorrelated with the noise in $u(z)$. The noise level in one component of vertical shear is thus

$$\sigma_{u_z} = \frac{\sqrt{2}}{\Delta z} \sigma_u = \frac{2.8 \times 10^{-4}}{\Delta z} \text{ s}^{-1} \quad (3.3)$$

where Δz is expressed in meters.

For $\Delta z = 2 \text{ m}$,

$$\sigma_{u_z} = 1.4 \times 10^{-4} \text{ s}^{-1} .$$

Vertical shear squared, S^2 , is given by

$$S^2 = u_z^2 + v_z^2 .$$

For purposes of this error analysis it is assumed that

$$\langle u_z^2 \rangle^{\frac{1}{2}} = \langle v_z^2 \rangle^{\frac{1}{2}} \text{ or } S^2 = 2u_z^2 , \quad (3.4)$$

and in the remaining discussion both components of shear will be represented by u_z .

Now according to Hajek (1969) a general function $g(x)$, of a random variable has the following expectation value μ and variance σ^2 :

$$\mu(g(x)) \approx g(\mu(x)) \quad (3.5a)$$

$$\sigma^2(g(x)) \approx [g'(\mu(x))]^2 \sigma^2(x) \quad (3.5b)$$

provided that

$$g'(x) \approx \text{constant for } |x - \mu(x)| < 3\sigma(x) . \quad (3.5c)$$

Now let

$$g(x) = S^2 (E_{u_z}) .$$

where according to (3.4)

$$S^2(E_{u_z}) = 2(u_z + E_{u_z})^2 . \quad (3.6)$$

Then $g'(x)$ becomes

$$\frac{d}{dE_{u_z}} \left[S^2(E_{u_z}) \right] = 4(u_z + E_{u_z}) .$$

so (3.5c) is satisfied provided $E_{u_z} \ll u_z$. From (3.3) and for $\Delta z = 2m$ this condition becomes $u_z \gg 1.4 \times 10^{-4} \text{ s}^{-1}$. Inspection of the YVETTE data shows this condition to be satisfied in nearly all observations. The rms noise in S^2 can therefore be estimated using (3.5b). Substituting (3.6) into (3.5b) the mean square noise is then

$$\sigma^2 \left(S^2(E_{u_z}) \right) = \sigma_{S^2}^2 \approx \left[4u_z(E_{u_z}) + 4u_z \right]^2 \sigma^2(E_{u_z}) . \quad (3.7)$$

But

$$\mu(E_{u_z}) = 0 ,$$

and

$$\sigma^2(E_{u_z}) = \sigma_{u_z}^2 = \left(\frac{\sqrt{2}}{\Delta z} \right)^2 \sigma_u^2 ,$$

So

$$\sigma_{S^2}^2 \approx \left[4u_z \cdot \frac{\sqrt{2}}{\Delta z} \right]^2 \sigma_u^2 . \quad (3.8)$$

Substituting (3.4) into (3.8)

$$\sigma_{S^2} \approx \frac{4S}{\Delta z} \sigma_u$$

or

$$\sigma_{S^2} \approx \left(\frac{8 \times 10^{-4} \text{ m s}^{-1}}{\Delta z} \right) S \quad (3.9)$$

Hence the noise level in S^2 is a function of both the vertical differencing interval, Δz , and the magnitude of the shear itself. For $\Delta z = 2\text{m}$,

$$\sigma_{S^2} \approx (4 \times 10^{-4} \text{ s}^{-1})S .$$

The way in which the relative noise level, σ_{S^2}/S^2 , varies with S^2 is illustrated in Figure 3.4. For $\Delta z = 2 \text{ m}$, the noise level exceeds the signal level for values of S^2 less than $1.0 \times 10^{-7} \text{ s}^{-2}$ (or values of S less than $4.0 \times 10^{-4} \text{ s}^{-1}$).

The accuracy of each component of vertical shear over small scales may be in error by as much as 9% due to a possible calibration error in the YVETTE velocity sensor. However, as noted earlier, this would be a systematic error which would cause all shear values to be consistently high or low. A 9% error in each component of vertical shear would lead to approximately 18% error in S^2 .

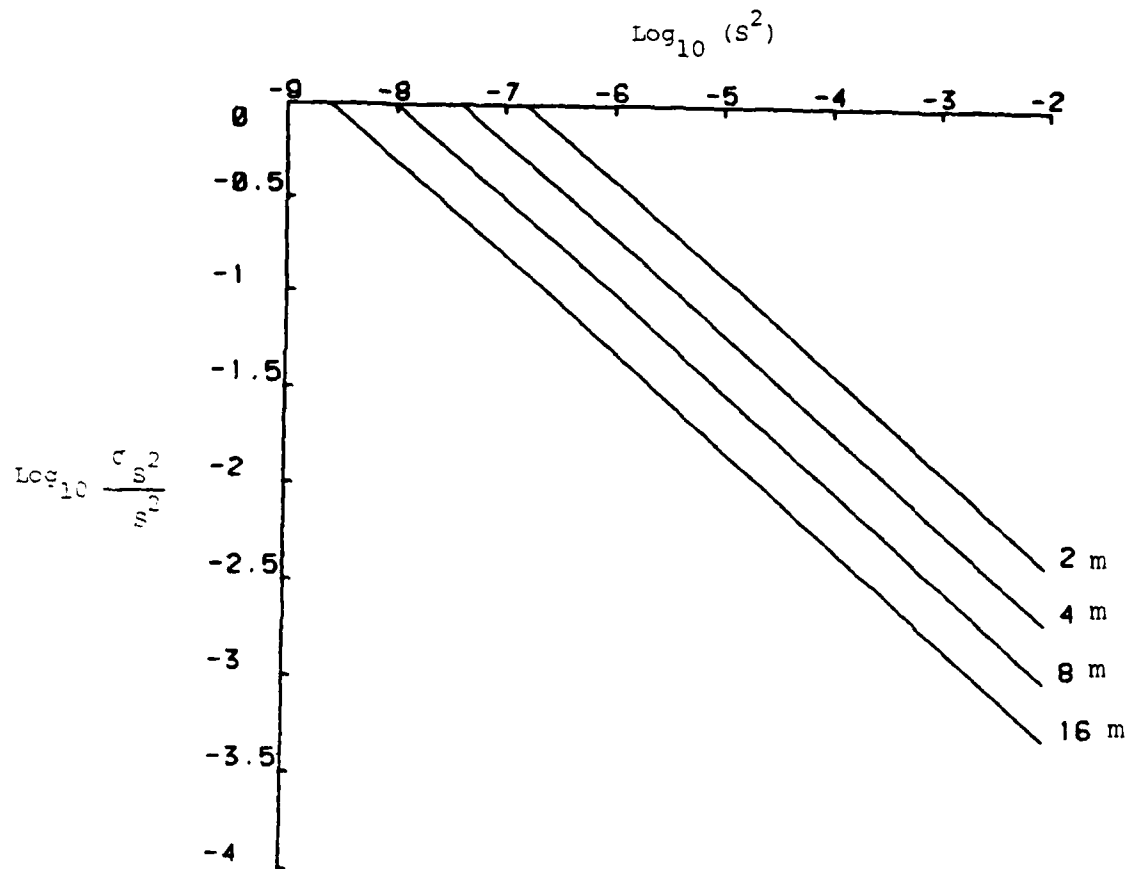

Figure 3.3 Logarithm of estimated relative error in S^2 versus logarithm of S^2 for vertical differencing intervals of 2, 4, 8, and 16m.

Section 4
SUMMARY AND CONCLUSIONS

This report has addressed questions regarding the magnitude of noise in YVETTE measurements of temperature, conductivity, pressure, and velocity and resulting noise in calculations of the square of Brunt-Vaisala frequency (N^2) and shear magnitude squared (S^2). Table 4.1 summarizes the noise estimates for each of the measured parameters. Implications of the estimated noise in N^2 and S^2 for recent analyses are discussed later in this section.

The combined noise from YVETTE temperature, conductivity, and pressure signals produces a relative noise level ($\frac{\sigma^2}{N^2}$) which can be summarized as follows for a vertical sample spacing corresponding to a pressure difference of $\Delta P = 2$ dbar:

$$\frac{\sigma^2}{N^2} = \frac{1.3 \times 10^{-6} (\text{rad s}^{-1})^2}{N^2}, \quad (N < 2 \times 10^{-2} \text{ rad s}^{-1})$$

$$\frac{\sigma^2}{N^2} = 1.57 \times 10^{-3}, \quad (N > 4 \times 10^{-2} \text{ rad s}^{-1}) .$$

For values of N between $2 \times 10^{-2} \text{ rad s}^{-1}$ and $4 \times 10^{-2} \text{ rad s}^{-1}$ the dependence of $\frac{\sigma^2}{N^2}$ undergoes a smooth transition from varying as N^{-2} to being independent of N . For vertical sample spacings corresponding to pressure differences other than 2 dbar, the above relative noise values must be multiplied by $(\frac{2 \text{ dbar}}{\Delta P})$.

Table 4.1

ESTIMATES OF NOISE IN YVETTE MEASUREMENTS

Parameter	Units	Range	Digital Resolution	Quantization Noise σ_Q	Estimate of System Noise σ_O	Estimate of Noise in Processed Data
Temperature	°C	-3 to 32	5×10^{-4}	1.4×10^{-4}	3.1×10^{-4}	1.9×10^{-4}
Conductivity	mmho cm^{-1}	1 to 65	1×10^{-3}	2.9×10^{-4}	2.9×10^{-4}	1.2×10^{-4}
Pressure	dbar	0 to 3200	5×10^{-2}	1.4×10^{-2}	2.9×10^{-2}	2.9×10^{-2}
Speed	cm s^{-1}	10^{-2} to 102	5×10^{-2}	1.4×10^{-2}	5×10^{-2}	7.6×10^{-3}
Compass Direction	degrees	0 to 360	3	8.7×10^{-1}	8.7×10^{-1}	1.3×10^{-1}

In the YVETTE data provided to SAI for analysis, temperature was not reported to sufficient precision. This effectively increased the quantization noise for temperature and increased the relative noise as follows for $\Delta P = 2$ dbar:

$$\frac{\sigma^2}{N^2} = \frac{2.2 \times 10^{-6} (\text{rad s}^{-1})^2}{N^2}, \quad (N \lesssim 10^{-2} \text{ rad s}^{-1}),$$

$$\frac{\sigma^2}{N^2} = 2 \times 10^{-2}, \quad (N \gtrsim 2 \times 10^{-2} \text{ rad s}^{-1}).$$

As in the previous case, the dependence of relative noise $\frac{\sigma^2}{N^2}$ on N undergoes a smooth transition over the range of N between 10^{-2} and 2×10^{-2} rad s^{-1} . For other vertical spacings the relative noise values must be adjusted by $\left(\frac{2 \text{ dbar}}{L P}\right)$ as before.

An evaluation of several types of velocity measurement error concluded that the only important sources of error are calibration errors of unknown magnitude and instrumental noise which is dominated by least bit quantization in the digital recording system. It is worth noting that the error due to application of Evans' motion correction algorithm has not been determined, but is assumed to be quite small. This assumption is based on a comparison of a profile obtained from Sanford's Absolute Velocity Profiler and a simultaneous YVETTE profile to which Evans' motion correction algorithm was applied.

The total error in S^2 over small scales derives from the noise level of the velocity sensor and a possible calibration error. The noise level in S^2 is estimated to be

$$\sigma_S^2 = \left(\frac{8 \times 10^{-4} \text{ m s}^{-1}}{\Delta z} \right) S .$$

The relative noise level $\frac{\sigma_S^2}{S^2}$ therefore becomes greater than 1.0 for values of S^2 less than $1.6 \times 10^{-7} \text{ s}^{-2}$ (or values of S less than $4.0 \times 10^{-4} \text{ s}^{-1}$).

Results of recent efforts to calibrate YVETTE velocity sensors differed by approximately 9% from calibration results two years earlier. Because the more recent calibration was less reliable, the earlier calibration results have been used in processing all YVETTE data. A 9% error could cause an 18% shift in the mean and variance of histograms of S^2 and a shift in statistics of Richardson number, but it would not change the form of observed distribution functions.

While measurement errors can affect quantitative conclusions resulting from analyses of YVETTE data, the qualitative nature of the conclusions of the SAI characterizations suggest that they are not significantly affected.

In Patterson, et al. (1981a and 1981b), the rms error in N^2 for a vertical difference interval $\Delta z = 2 \text{ m}$ was estimated to be $1.75 \times 10^{-6} \text{ s}^{-2}$ which is slightly lower than $2.38 \times 10^{-6} \text{ s}^{-2}$ from Figure 2.3 for $N < 10^{-2} \text{ s}^{-1}$. For $N > 10^{-2} \text{ s}^{-1}$ ($N^2 > 10^{-4} \text{ s}^{-1}$) the error is estimated at a fixed 2% of N^2 . The rms error estimated for S^2 ($\Delta z = 2 \text{ m}$) in Patterson, et al. (1981a and 1981b) was $3.4 \times 10^{-8} \text{ s}^{-2}$ while this report estimates the error to be $(4 \times 10^{-4} \text{ s}^{-1})S$ increasing linearly with S . These differences in estimated error are not large

enough to significantly affect the results and conclusions of Patterson, et al. (1981a and 1981b).

In Newman, et al. (1981), the rms error in N^2 for $\Delta z = 2$ m was estimated to be $1.35 \times 10^{-6} \text{ s}^{-2}$ and the rms error in S^2 to be $(2.24 \times 10^{-4} \text{ s}^{-1})S + 1.25 \times 10^{-8} \text{ s}^{-2}$. Again, these estimates are approximately a factor of two smaller than our current estimates, but the results and conclusions of that report are essentially unchanged.

REFERENCES

- Evans, D.L., H.T. Rossby, M. Mork, and T. Gytre, 1979: YVETTE - a free-fall shear profiler. Deep-Sea Res., 26, 703-718.
- Fofonoff, N., S. Hayes, and R. Millard, 1974: WHOI/Brown microprofiler: methods of calibration and data handling. Woods Hole Oceanographic Institution Technical Report 74-89 (unpublished manuscript), 66 pp.
- Gregg, M.C., 1979: The effects of bias error and system noise on parameters computed from C,T,P, and V profiles. J. of Phys. Oceanogr., 9, 199-217.
- Hajek, J., 1969: Probability Theory, chapter 33 in Survey of Applicable Mathematics, K. Rektorys (ed.), M.I.T. Press, Cambridge, Mass.
- Joyce, T.M., 1976: Large-scale variations in small-scale temperature/salinity fine structure in the main thermocline of the northwest Atlantic. Deep-Sea Res., 23, 1175-1186.
- Lambert, R.B., Jr., D.L. Evans, and P.J. Hendricks, 1980: Data Report - SCIMP and YVETTE, Progress Report I. Ocean Physics Division Technical Report 80-201-04, Science Applications, Inc., McLean, Virginia.
- Lambert, R.B., Jr., and S.L. Patterson, 1980: Review of upper ocean vertical shear. Ocean Physics Division Technical Report 80-201-02, Science Applications, Inc., McLean, Virginia, 170 pp. (CONFIDENTIAL).
- Newman, F.C., S.L. Patterson, D.M. Rubenstein, and R.B. Lambert, Jr., 1981: Some methods of calculating Richardson Number from observed data. Ocean Physics Division Technical Report 81-201-01, Science Applications, Inc., McLean, Virginia, 71 pp.
- Patterson, S.L., F.C. Newman, D.M. Rubenstein, R.B. Lambert, Jr., 1981a: Spatial distribution of vertical shear. Ocean Physics Division Technical Report 81-201-02, Science Applications, Inc., McLean, Virginia, 137 pp.
- Patterson, S.L., F.C. Newman, R.B. Lambert, Jr., 1981b: Observed spatial variations in Richardson Number Statistics. Ocean Physics Division Technical Report 81-201-05, Science Applications, Inc., McLean, Virginia, 41 pp.

REFERENCES (Continued)

Rubenstein, D.M., F.C. Newman, and R.B. Lambert, Jr., 1981:
A comparison of vertical shear profilers: YVETTE and
SCIMP. Ocean Physics Division Technical Report 80-201-05,
Science Applications, Inc., McLean, Virginia, 55 pp.

FILMED
7-8