

MICROCOPY RESOLUTION TEST CHART
NATIONAL BUREAU OF STANDARDS-1963-A

①

*A STUDY OF
EMBEDDED COMPUTER SYSTEMS SUPPORT
VOLUME IV
REQUIREMENTS BASELINE:
AUTOMATIC TEST EQUIPMENT*

September 1980

APPROVED FOR PUBLIC RELEASE
DISTRIBUTION UNLIMITED

CDRL 02A
Contract Number F33600-79-C-0540

DTIC
SELECTED
JUN 11 1982
H

Prepared for
Air Force Logistics Command AFLC/LOEC
Wright Patterson AFB, Ohio 45433

UNCLASSIFIED/UNLIMITED

ONE SPACE PARK • REDONDO BEACH • CALIFORNIA 90278

TRW
DEFENSE AND SPACE SYSTEMS GROUP

82 06 11 006

AD A115456

DTIC FILE COPY

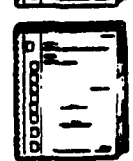
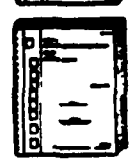
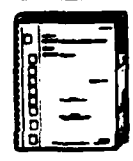

Unclassified

SECURITY CLASSIFICATION OF THIS PAGE (When Data Entered)

REPORT DOCUMENTATION PAGE		READ INSTRUCTIONS BEFORE COMPLETING FORM
1. REPORT NUMBER	2. GOVT ACCESSION NO. AP-4115-4256	3. RECIPIENT'S CATALOG NUMBER
4. TITLE (and Subtitle) Embedded Computer System Support Volume 4-Requirements Baseline: Automatic Test Equipment		5. TYPE OF REPORT & PERIOD COVERED Final
		6. PERFORMING ORG. REPORT NUMBER 47169D
7. AUTHOR(s)		8. CONTRACT OR GRANT NUMBER(s) F33600-79-C-0540
9. PERFORMING ORGANIZATION NAME AND ADDRESS TRW Systems Inc One Space Park Redondo Beach, CA 90278		10. PROGRAM ELEMENT, PROJECT, TASK AREA & WORK UNIT NUMBERS
11. CONTROLLING OFFICE NAME AND ADDRESS HQ AFLC/LOEE Wright-Patterson AFB, OH 45433		12. REPORT DATE Sept 1980
		13. NUMBER OF PAGES 111
14. MONITORING AGENCY NAME & ADDRESS (if different from Controlling Office)		15. SECURITY CLASS. (of this report) Unclassified
		15a. DECLASSIFICATION/DOWNGRADING SCHEDULE
16. DISTRIBUTION STATEMENT (of this Report) Approved for Public Release, Distribution Unlimited.		
17. DISTRIBUTION STATEMENT (of the abstract entered in Block 20, if different from Report)		
18. SUPPLEMENTARY NOTES Recommendations pertaining to administrative and programmatic initiatives are presented in this volume. Companion documents dated October 1981, September 1980, same contract number.		
19. KEY WORDS (Continue on reverse side if necessary and identify by block number) Materiel Management ECS Computerized Systems Logistics Support Weapons Systems Avionics Logistics Management Technology Forecasts Planning Program Management		
20. ABSTRACT (Continue on reverse side if necessary and identify by block number) Volume 4 of the "Embedded Computer Systems (ECS) Support" study focuses on ECS as it relates to Automatic Test Equipment (ATE). It presents the background and current status of the Air Force Logistics Command support of ATE. (See related volumes: LD 47169A, B, C, E, F, G, H, J, K and L). Conclusions: See volume 1 (LD 47169A). Recommendations: See volume 1 (LD 47169A).		



*A STUDY OF
EMBEDDED COMPUTER SYSTEMS SUPPORT
VOLUME IV
REQUIREMENTS BASELINE:
AUTOMATIC TEST EQUIPMENT*



September 1980

CDRL 02A
Contract Number F33600-79-C-0540

Prepared for
Air Force Logistics Command AFLC/LOEC
Wright Patterson AFB, Ohio 45433

FOREWORD

This volume is one of nine individually bound volumes that constitute the Phase II Final Report "Study of Embedded Computer Systems Support" for Contract F33600-79-C-0540. The efforts and analyses reported in these volumes were sponsored by AFLC/LOEC and cover a reporting period from September 1979 through September 1980.

The nine volumes are

<u>Volume</u>	<u>Title</u>
I	Executive Overview (CDRL 05)
II	Selected ECS Support Issues: Recommendations/ Alternatives (CDRL 02A)
III	Requirements Baseline: Aircrew Training Devices (CDRL 02A)
IV	Requirements Baseline: Automatic Test Equipment (CDRL 02A)
V	Requirements Baseline: Communications-Electronics (CDRL 02A)
VI	Requirements Baseline: Electronic Warfare (CDRL 02A)
VII	Requirements Baseline: Operational Flight Programs (CDRL 02A)
VIII	ECS Technology Forecast (CDRL 03)
IX	National Software Works Investigation (CDRL 04)



Accession For <input checked="" type="checkbox"/> DTIC GRA&I <input type="checkbox"/> DTIC TAB <input type="checkbox"/> Unannounced <input type="checkbox"/> Justification	By Distribution/ Availability Codes	Avail and/or Special	Dist A
--	---	-------------------------	---

CONTENTS

FOREWARD	ii
ABBREVIATIONS AND ACRONYMS	viii
1. AUTOMATIC TEST SYSTEMS	1-1
1.1 Introduction	1-1
1.2 Definitions	1-2
1.2.1 Automatic Test Equipment	1-2
1.2.2 Automatic Test System	1-2
1.2.3 ATE Control Software	1-3
1.2.4 ATE Support Software	1-3
1.2.5 Built-In-Test	1-3
1.2.6 Interface Test Adapter	1-3
1.2.7 Self-Test	1-3
1.2.8 Simulator Test	1-4
1.2.9 Support Equipment	1-4
1.2.10 Test Point	1-4
1.2.11 Test Program Set	1-4
1.2.12 Test Requirements Document	1-4
1.2.13 Test Requirements Document	1-5
1.2.14 Test Software	1-5
1.2.15 Test Support Software	1-5
1.2.16 Unit Under Test	1-5
1.2.17 Unit Under Test Manager	1-5
1.3 ATE System Identification	1-6
1.4 Typical ATE System Functions	1-11
1.4.1 Typical Digital ATE Functions	1-11
1.4.2 Typical ATE System Functions in Engine Testing	1-19
1.5 ATE System Relationship to Roles, Missions	1-24

CONTENTS (Continued)

2.	ATE SUPPORT REQUIREMENTS	2-1
2.1	ECS Change.	2-1
2.1.1	Receive and Process Requests	2-1
2.1.2	Preliminary Analysis and Problem/ Deficiency Definition	2-4
2.1.3	Preliminary Resource Allocation and Scheduling	2-4
2.2	Change Analysis and Specification	2-4
2.2.1	Establish Change Feasibility	2-4
2.2.2	Requirements Decomposition/Definition	2-4
2.2.3	Preliminary Design	2-4
2.2.4	Detailed Design	2-4
2.2.5	Generate Change Proposal	2-5
2.3	Engineering Development and Unit Test	2-5
2.3.1	Develop the Change	2-5
2.3.2	Perform Engineering Tests	2-5
2.4	System Integration and Test	2-5
2.4.1	Test ATE System Performance	2-5
2.4.2	Test Weapon System Performance	2-5
2.4.3	Produce Test Results	2-5
2.5	Change Documentation	2-5
2.5.1	Document ATE Changes	2-5
2.5.2	Update ATE Baseline	2-6
2.5.3	Configuration Control	2-6
2.6	Certification and Distribution	2-6
2.6.1	Certify Documentation	2-6
2.6.2	Distribute Revised ATE System Data	2-6
2.6.3	Provide Installation Procedures/ Instructions	2-6

CONTENTS (Concluded)

3.	ATE SUPPORT CONCEPT DESCRIPTION	3-1
3.1	Management Concept	3-1
3.1.1	Management Concept Assessment	3-8
3.2	Logistics Support Concept	3-8
3.3	ATE Software Change Process/Concept	3-9
3.3.1	ATE Software Changes	3-9
3.3.2	Engine and Component Testing Concept	3-13
3.3.3	Change Forms and Procedures	3-16
3.3.4	Change Process Assessment	3-17
3.4	ATE Organizational Concept	3-19
3.4.1	Organization Concept Assessment	3-22
4.	REPRESENTATIVE SYSTEM AND ATE SUPPORT	4-1
4.1	F-15 Automatic Test Equipment Support	4-1
5.	ASSESSMENTS AND DISCUSSIONS	5-1
5.1	Acquisition/Development Discussion	5-1
5.1.1	Modular Automatic Test Equipment Project	5-2
5.1.2	Test Program Set Development	5-4
5.1.3	UUT Test Program Quality	5-4
5.1.4	Design for Testability	5-10
5.1.5	Software Support Center Developments	5-11
5.1.6	Equipment Modifications	5-14
5.2	Management Considerations	5-14
5.2.1	Agency Responsibilities	5-15
5.2.2	Configuration Management	5-19
5.2.3	Logistics Management Applied to Engineering Problems	5-20
5.3	Industry Versus Air Force Comparisons	5-21
5.4	Other ATE Interest Areas	5-22
5.4.1	Test Aids	5-22
5.4.2	Test Approach to F-16 ATE	5-24
	APPENDIX A: SA-ALC ATE EQUIPMENT TEST	A-1

TABLES

1-1.	F-15 ATE Overview	1-9
1-2	F-15 ATE ITA/TP/UUT Overview.	1-26
2-1.	ATE System Support Requirements	2-2
3-1.	F-15 UUT/WUC Distribution	3-6
3-2.	F-15 ATE Distribution by ALC.	3-7
3-3.	Automatic Test Pattern Generators for F-15 ATE	3-12
3-4.	Off-Line ATE Software Support Requirements	3-14
4-1.	F-15 Automatic Test Equipment Overview	4-2
4-2.	F-15 ATE Software Overview	4-4
4-3.	F-15 ATE Test Programs	4-5
4-4.	F100 Engine Test Stands	4-6
4-5.	F100 Engine Depot ATE Computer Programs	4-7
5-1.	Extracts from AFLCR 66-37	5-12
5-2.	SSC Software Development Levels	5-13

ILLUSTRATIONS

1-1.	Relationship of ATE Testing Levels for System X	1-7
1-2.	Automatic Test System Block Diagram	1-12
1-3.	Types and Functions of ATE	1-15
1-4.	Off-line Automatic Test System	1-16
1-5.	Block Diagram of Pacer Comet Mark II Test System	1-21
3-1.	Automatic Test System (ATE SM Assignment)	3-2
3-2.	Automatic Test System (UT Manager Assignment)	3-4
3-3.	Automatic Test System (FSG-70 Assignment)	3-5
3-4.	Management Level Chart	3-18
3-5.	ATE Information Flow	3-20
3-6.	AFLC Software Support Center Chain of Command	3-23
4-1.	F-15 ATE System Interrelationships	4-8
5-1.	USAF MATE Program Plan	5-3
5-2.	Major Tasks in the Preparation of an ATE Program	5-5
5-3.	Process of TPS Generation	5-6
5-4.	TRD Acquisition	5-8
5-5.	TRD Data Validation	5-9
5-6.	ATE Related ADPE Acquisition Procedures	5-16

ABBREVIATIONS AND ACRONYMS

ADPE	Automatic Data Processing Equipment
ADTS	Avionics Depot Test System
AIS	Avionics Intermediate Shop
ATE	Automatic Test Equipment
ATLAS	Abbreviated Test Language for All Systems
ATPG	Automatic Test Pattern Generator
ATS	Automatic Test System
CPIN	Computer Program Identification Number
DOD	Department of Defense
IEEE	Institute of Electrical and Electronics Engineers
IM	Item Manager
ITA	Interface Test Adapter
LRU	Line Replaceable Unit
MDR	Materiel Deficiency Report
MIP	Materiel Improvement Project
NATO	North Atlantic Treaty Organization
SM	System Manager
SRU	Shop Replaceable Unit
SSC	Software Support Center
TPI	Test Program Instructions
TPS	Test Program Set
TRC	Technical Repair Center
TRD	Test Requirements Document
UUT	Unit Under Test

1. AUTOMATIC TEST SYSTEMS

1.1 INTRODUCTION

Automatic testing began in the 1950's as a result of the advent of equipment that required high-speed device testing. The sequence of simple tests were so numerous and frequent that an electrical means was devised to administer the tests. In subsequent years the explosive growth of semiconductor devices created an additional demand for automatic test equipment. The semiconductor devices were physically mounted on boards known as circuit boards. As the growth in circuit boards paralleled the growth of test devices, the technician found himself unable to adequately test with an oscilloscope, thus subassembly testing was born.

Since those times the electronic products themselves have magnified in complexity and number and automatic testing has been forced to include fault diagnosis which has increased the complexity of the ATE. As any new break through in electronics occurs (such as large scale integration), additional demands are created for new or revised ATE. It is apparent from this description that the ATE arena has been and remains in the midst of a fierce evolution.

As the needs for ATE intensified, AFLC was faced with the dilemma of reduced numbers of personnel and a threat of less training for support personnel. The concept of using automatic testing, where practical, to replace added manning was conceived and implemented. Ideally, additional machine controlled tests would require fewer trained personnel to accomplish the required tests. Accordingly, the Air Force has supported expanded usage of automatic test methods in spite of the rapid technological evolution of automatic test systems.

Support for Automatic Test Systems has progressed to an equally dynamic state and as the criticality of avionics to the aircraft's mission becomes more acute the importance of ATE increases. AFLC is aware of the dynamic situation and is taking steps to improve the support of ATE and the avionics which utilize ATE. This volume describes the current baseline for ATE support throughout the command.

1.2 DEFINITIONS

Several definitions are offered here so that a common basis of understanding is established for discussion of ATE support. Those definitions marked with an asterisk were extracted from the IEEE Standard Dictionary of Electrical and Electronics Terms.

1.2.1 Automatic Test Equipment

Electronic devices capable of automatically or semiautomatically generating and independently furnishing programmed stimuli; measuring selected parameters of an electronic, mechanical, or electro-mechanical item being tested; and making a comparison to accept or reject the measured values in accordance with predetermined limits. ATE may also include independently configured automatic or semiautomatic devices which are capable of detecting, measuring, and evaluating electrical, electronic, or electro-mechanical characteristics of system/equipment. ATE normally operates by use of previously prepared test software recorded on punched tape, card decks, magnetic tapes, disc pack, or other storage media.

1.2.2 Automatic Test System

Those equipment, software, and data items required to operate and maintain ATE and test software used thereon. This system includes test equipment, interface test adapters, test software, compilers, programming information, tester data, but not off-line Automatic Data Processing Equipment (ADPE) used in support of test software.

1.2.3 ATE Control Software

Software used during execution of a test program which controls the non-testing operations of the ATE. This software is used to execute a test procedure, but does not contain any of the stimuli or measurement parameters used in testing the Unit Under Test (UUT). Where test software and control software are combined in one inseparable program, that program will be treated as test software, not control software.

1.2.4 ATE Support Software

Computer programs which aid in preparing, analyzing, and maintaining test software. This software includes ATE compilers, translation/analysis programs, and punch/print programs. This software is never used during the execution of a test program on a tester. Support software may exist off-line to the ATE or may be resident (on-line) in the ATE.

1.2.5 Built-In-Test*

A test approach using built-in-test equipment or self-test hardware or software to test all or part of the unit under test.

1.2.6 Interface Test Adapter

The equipment necessary to provide physical and/or electrical compatibility between the UUT and the ATE. The Interface Test Adapter (ITA) normally consists of cabling, wiring, connectors, and miscellaneous components.

1.2.7 Self-Test*

A test or series of tests performed by a device upon itself, which shows whether or not it is operating within designed limits. This includes test programs on computers and automatic test equipment which check out their performance status and readiness.

1.2.8 Simulator Test*

A device or program used for test purposes which simulates a desired system or condition providing proper inputs and terminations for the equipment under test.

1.2.9 Support Equipment*

Equipment required to make an item, system, or facility operational in its environment. This includes all equipment required to maintain and operate the item, system, or facility and the computer programs related thereto. (ATE is a subset of support equipment).

1.2.10 Test Point*

A convenient, safe access to a circuit or system so that a significant quantity can be measured or introduced to facilitate maintenance, repair, calibration, alignment, and check out.

1.2.11 Test Program Set

A Test Program Set (TPS) consists of a complete software package, including test tape or disc, interface test adapter, and test program instructions. (TPS is sometimes used by the Air Force as an abbreviation for Test Program Specification. The use throughout this document applies to Test Program Set only.)

1.2.12 Test Requirements Document*

The document that specifies the tests and test conditions required to test and fault isolate a unit under test.

1.2.13 Test Requirements Document

A document, described by MIL-STD 1519, which records performance and calibration requirements of testable end items. †

1.2.14 Test Software

Computer programs which control the testing operations and procedures (including certification and fault isolation procedures) of the ATE. The program(s) used to control the stimulus and measurement parameters used in testing the UUT. It is also referred to as a test program or test tape.

1.2.15 Test Support Software*

Computer programs used to prepare, analyze, and maintain test software. Test software includes Automatic Test Equipment (ATE) compilers, translation/analysis programs, and punch/print programs.

1.2.16 Unit Under Test*

Any system, set, subsystem, assembly, subassembly, etc., undergoing testing.

1.2.17 Unit Under Test Manager

The organization assigned material management responsibility for the prime equipment subject to automatic testing, that is, the UUT.

† There are two definitions of TRD's included because they differ in their content. The IEEE definition encompasses fault isolation while the definition extracted from AFLCR 66-37 includes calibration requirements. Use of the term TRD in this volume is intended to include a composite of both definitions.

1.3 ATE SYSTEM IDENTIFICATION

The varied ways that automatic equipment is used to solve testing problems indicates that no unique general purpose way to accommodate all of these test requirements exists. In addition, there is no centralized acquisition or management activity to control proliferations. Each test user approaches automatic testing with his own particular needs and tends to optimize his specific test system to solve his needs. As a result the total number of ATE currently within AFLC responsibility is very large and the potential for even more systems is high as future weapons systems are acquired.

During acquisition of a weapon system AFLC provides assistance to AFSC in determining the support equipment (to include ATE) that will be necessary for life cycle support of the weapon system. AFSC is charged with the responsibility to procure the weapon system and the support equipment. Subsequent to Program Management Responsibility Transfer (PMRT) AFLC assumes complete management responsibility for the support of the weapon system. At that time the weapon system normally has become operational and all levels of testing should be supportable.

AFLC is involved in three levels of testing using automatic equipment: organizational, intermediate, and depot. (The combination of organizational and intermediate is occasionally referred to as field level.) A complete baseline of ATE would encompass the entire set of ATE for all three test levels. While only one baseline may appear convenient from a Headquarters AFLC perspective, actual implementation of only one overall testing level is impractical due to increased costs and the wide variance between depot and organizational testing levels. Figure 1-1 indicates the affiliation of the three testing levels.

Notice that although ATE applies at all three testing levels the extent or type of testing varies from level to level. Typically there is only one group of UUT test programs and one test set for each avionics

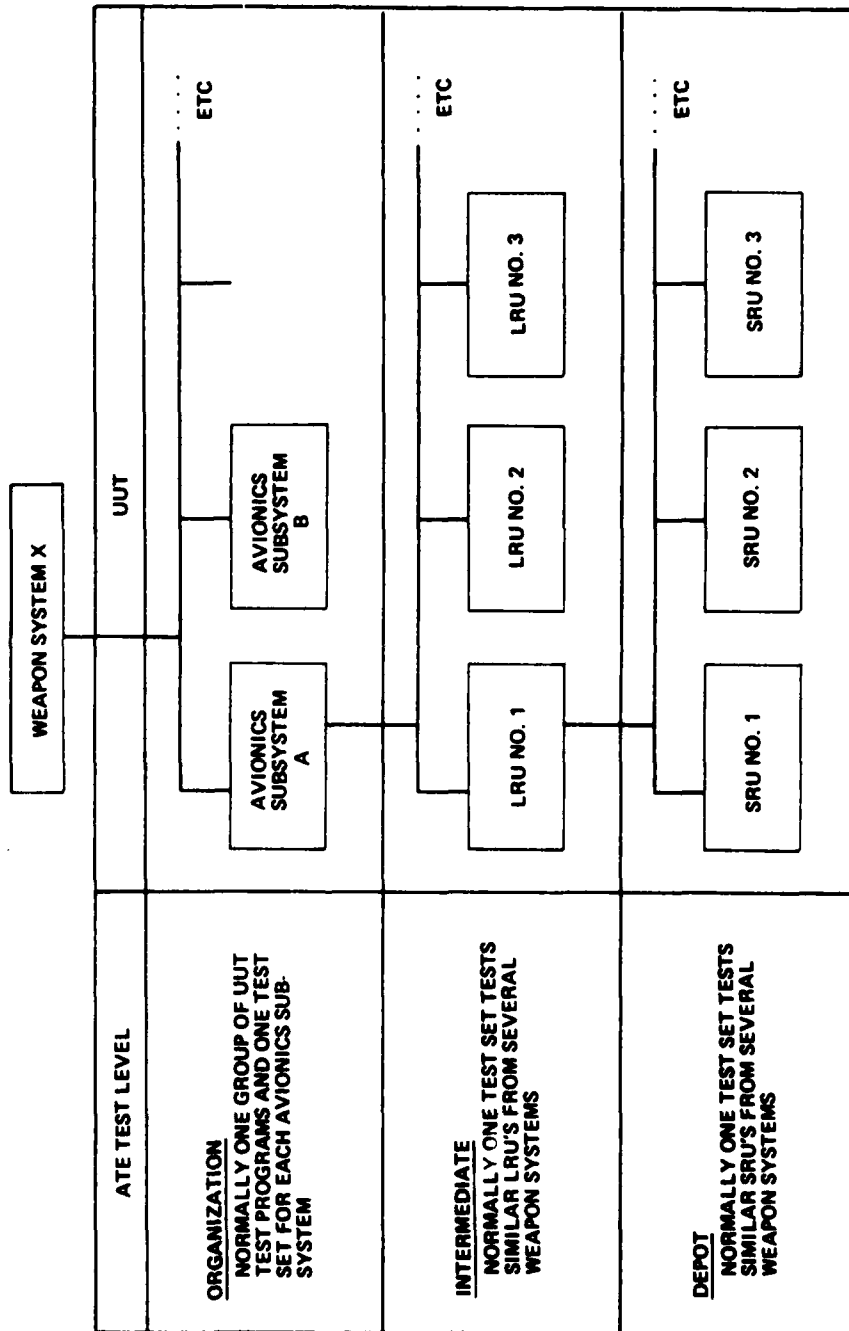

Figure 1-1. Relationship of ATE Testing Levels for System X

system at the organizational level. Ideally, but also impractically, the one test set could apply to more than one avionics system which would reduce the overall number of test sets required, however this is not the case for most avionics systems. At the intermediate level at least one UUT program exists for each Line Replaceable Unit (LRU) and as many test sets exist as are required. That is, if there are 7 LRU's total and test set (A) will test 3 of the SRU's and another test set (B) will test 2 LRU's and the other 2 LRU's required unique test sets then a total of 4 test sets are required with 7 UUT test programs. A similar example could be cited where individual UUT's require more than one test program. At the depot level SRU's are tested for component failure.

The APG-63 radar set which is used on the F-15 weapon system could be used as an example of avionics subsystem A in Figure 1-1. There are 9 LRU's and over 200 SRU's in the APG-63. If all subsystems used on all weapon systems are totaled for AFLC, then it is evident that vast numbers of test sets and test programs are required to provide ATE support.

If the F-15 is again used as the example of weapon system X in Figure 1-1, then the system management is accomplished by the F-15 SM. The three levels of ATE are managed by item managers who are not all necessarily collocated with the SM. The SM is responsible for knowing who the respective item managers are for his system and for integrating their efforts to provide support for his system. Management complexity intensifies when certain avionics subsystems, LRU's, or SRU's are used on more than one weapon system. Thus an item manager is now supporting multiple SM's.

The total ATE baseline within the command is the composite of all UUT programs and test sets for all weapon systems readjusted for any common equipment and/or programs that apply to multiple avionics subsystems, LRU's, or SRU's. Table 1-1 indicates an overview of the ATE for the F-15 aircraft. Note the multiplicity of testers, vendors, and users involved with only this one weapon system.

Table 1-1. F-15 ATE Overview

ATE	Application	Vendor	Integration Contractor	User
Aircraft Built-in-Test	Detection of failed LRU	-	MCAIR	Organisational (Flight Line)
Avionics Intermediate Shop (AIS)	LRU Test at Intermediate and Depot Level (TRC and PDM)	Bendix	MCAIR	Warner Robins ALC Intermediate (All) ATC RTE (All)
Computer Station				
Displays Station				
Microwave Station				
Avionics Depot Test Station (ADTS)	Module Test-Depot Level	Honeywell (Emerson Sub on IF Video/Microwave)	MCAIR	Warner Robins ALC
Expanded Memory Station				
Digital Station				Sacramento ALC
Analog Station				Oklahoma ALC
Multifunction Station	Module Test-Depot Level	Sperry	MCAIR	Ogden ALC
COMETS Digital Station (66FC)	Module Test-Depot Level	General Dynamics (GFE)	MCAIR	Sacramento ALC
COMETS AGE Tester (6861)	AIS Module Test-Depot Level	General Dynamics (GFE)	MCAIR	Ogden ALC
COMETS AGE Tester (Model 310)		Bendix	SA/ALC	SA/ALC
Kelly Microwave Tester	AIS Module Test-Depot Level	SA/ALC	SA/ALC	SA/ALC
Power Supply Tester	AIS Module Test-Depot Level	SA/ALC	SA/ALC	SA/ALC
Gen RAD 1792D/1796	AIS Module Test-Depot Level	GEN RAD	SA/ALC	SA/ALC
INS Test Station	INS LRU and Module Test-Depot Level	Litton	MCAIR	AGMC
AAI 5500	KB-27 Gun Camera Test	GFE	Ogden ALC	Ogden ALC
Tactical Electronic Warfare System (TEWS)	LRU Test at Intermediate and Depot Levels	Honeywell (Emerson Sub)	MCAIR	Warner Robins ALC Intermediate
Intermediate Test Station				
TEWS Depot Test Station	Module Test-Depot Level	HP/HP	Northrop/MCAIR	Warner Robins ALC
HPADTS (DTS 70)	Radar FSP Module Test-Depot Level	HP	MCAIR	Warner Robins ALC

Appendix A contains a listing of all the ATE systems within SA-ALC responsibility. A count of the number of systems will not necessarily indicate the scope of total support requirements because each system has different demands upon time and personnel. ATE software is also a part of the current baseline. Identification of all software programs is a requirement of the Computer Program Identification Number (CPIN) system. Category 85 of the CPIN system singles out the computer programs peculiar to test stations and testers. This system, managed by OC-ALC, indicates category 85 programs by subcategories of

- Electronic warfare
- Communications
- Data processing and display
- Engines
- Flight controls
- Guidance
- Navigation
- Weapons delivery
- Fire control
- Electronic and electrical
- Armament and munitions
- Multiple major functions
- Hydraulic
- Pneumatic
- Pseudraulic
- Vacuum
- Surveillance/tracking
- General purpose or supportive

In the future, interrogating the CPIN system will indicate the number of test related programs for any subcategory. The initial data base for the CPIN system is not yet complete and the system is currently resident

on a word processor type machine. As a result the CPIN system is still a manual capability, but to be highly useful its dynamic data base state requires a computer aided, rapidly updateable capability. Currently, the CPIN system contains reference to only approximately 7200 ATE computer programs.

Numbers of computer programs are of keen interest but again are not reflective of the scope of total support requirements. As an example, one program could demand several hours and several personnel to execute the program while dozens of other programs could quickly be executed by a single person.

1.4 TYPICAL ATE SYSTEM FUNCTIONS

This section is addressed in two main parts, digital testing and engine testing. Coverage of these two types of automatic testing represents the bulk of software support problems encountered with ATE. Both types of testing have some degree of similarity; however, engine testing exercises mechanical and pneumatic testing of equipment as opposed to pure electronics testing.

1.4.1 Typical Digital ATE Functions

A generalized block diagram of an Automatic Test System (ATS) is outlined in Figure 1-2. Although the ATS can vary from a simple system to a complex system either the simplified or the complex ATS accomplishes tests via functions as outlined in the figure.

The test program tape or disc contains the coded sequence that activates the ATE with a set of instructions to automatically ascertain the operational readiness condition of the UUT, and if faulty, to isolate the fault to the required level for maintenance action.

Mechanical and electrical connection and conditioning between the ATE and UUT is provided by the Interface Test Adapter (ITA). The Test Program Instructions (TPI) provide sequential directives for execution of a test program to include set-up/tear-down steps, loading, adjustments, etc.

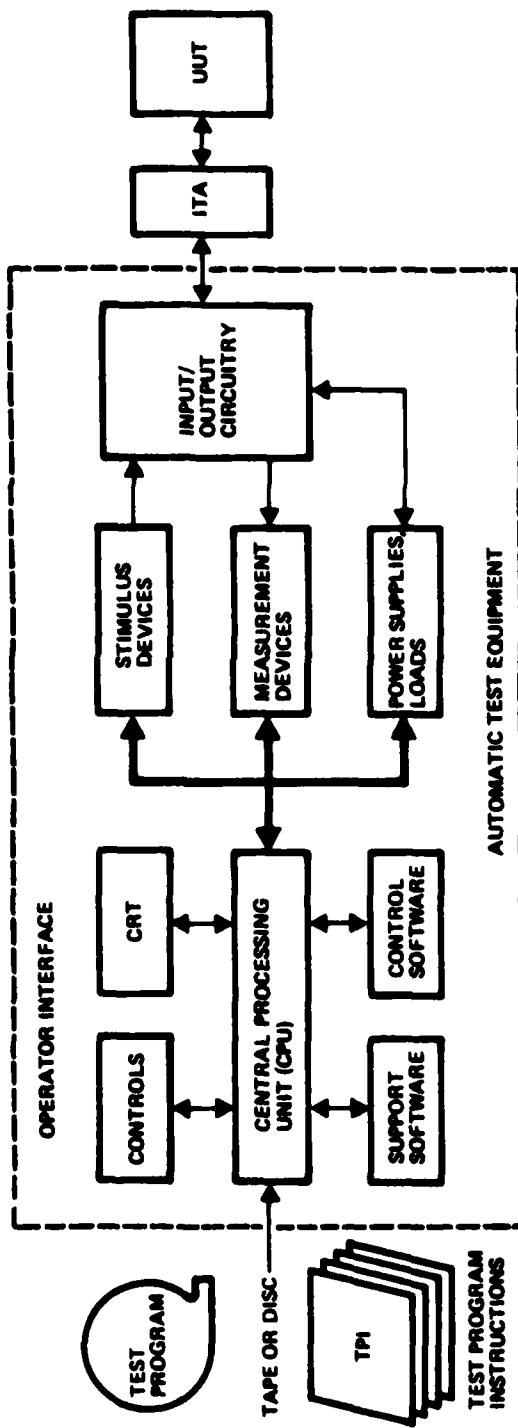

Figure 1-2. Automatic Test System Block Diagram

In summary, the UUT is exercised by the ATE through the ITA connection by the test program as amplified by the test program instructions.

In normal operational methods, the test requirements and UUT source data specified in the Test Requirements Document (TRD) are analyzed to develop a test strategy. Based on the test strategy the test design engineer develops the detailed test logic which is converted to the test program language. This UUT program is processed into an executable code as required by the ATE processor. At run time, the test program is loaded into the ATE's Central Processing Unit (CPU) and executed similarly to any other computer program. During program execution one or more stimuli are selected and input to the UUT. The UUT response is detected and measured for immediate comparison to pre-established pass/fail conditions or, in a few cases, the response is recorded for future evaluation. Results of all the comparisons and evaluations indicate the condition of the UUT and either passes or fails the UUT. Test data and operator instructions may be Cathode Ray Tube (CRT) displayed during program execution and certain operations may require operator actions to be entered through the operator interface. When testing is complete the operator is notified via the CRT and the UUT is ready for removal from the test system.

The previous discussion presented a simplified description of how ATS's function, however the magnitude of testing or number of tests required are of utmost concern. In the case of a purely digital UUT the total number of different test combinations possible is 2^n where n is the number of inputs. That is, a UUT with 10 inputs would represent a total of ($2^{10} = 1024$) different test combinations possible. Sequential logic circuitry would represent even more possible combinations. Larger numbers of inputs (some UUT's contain over 200 inputs) are common in UUT's and the magnitude of total test combinations is astronomical as the number of inputs grow. Additionally, each input combination used must be measured for UUT response. As a consequence, the test program must be carefully constructed and executable in rapid sequence. In most cases the central processor executes thousands of test combinations within a few minutes; however, seldom is a UUT exhaustively tested (every possible combination checked).

When literally thousands of tests are required, it is illogical and sometimes impossible to use unique, separate wires for each test. Instead a switching action occurs within the input/output circuitry function box. Because many of the newer UUT's require high speed checking, the switching frequency can approach several MHz (million cycles per second) and thus becomes quite complex. At high frequency, physical separation becomes a problem due to signal attenuation. Due to this, many of the testers are moving toward circular or cylindrical configurations to physically allow each test to use equivalent electrical signals.

1.4.1.1 ATE Complexity

To this point the ATE method of testing seems rather simple and straightforward; however, it is more complex than it appears. The next few paragraphs are written to create a feeling for the true complexities involved.

Figure 1-3 indicates that two kinds of ATE exist, on-line and off-line. On-line is defined as being resident in the UUT; this is an attempt at prompting the UUT to check itself. The functions of on-line ATE are as indicated in the figure.

Off-line ATE is depicted in Figure 1-3 as having two functions. An alternate way of thinking of off-line functions is: control, stimulus, measurement, switching, and input/output. Figure 1-4 gives an indication of the interfaces for these functions and the types of data exchanged between them.

Examples which typically apply to some of the functional blocks in Figure 1-4 are:

- Stimulus subsystem - pulse generators, waveform generators, special functions, digital signals.
- Measurement subsystem - digital multimeters, counters/timers, waveform analyzers, spectrum analyzers, distortion analyzers, transfer function analyzers, frequency meters, power meters, programmable oscilloscopes.
- Interface test adapters - can vary in complexity from simple wiring to computer controlled parameters for supplementing short falls of the ATE.

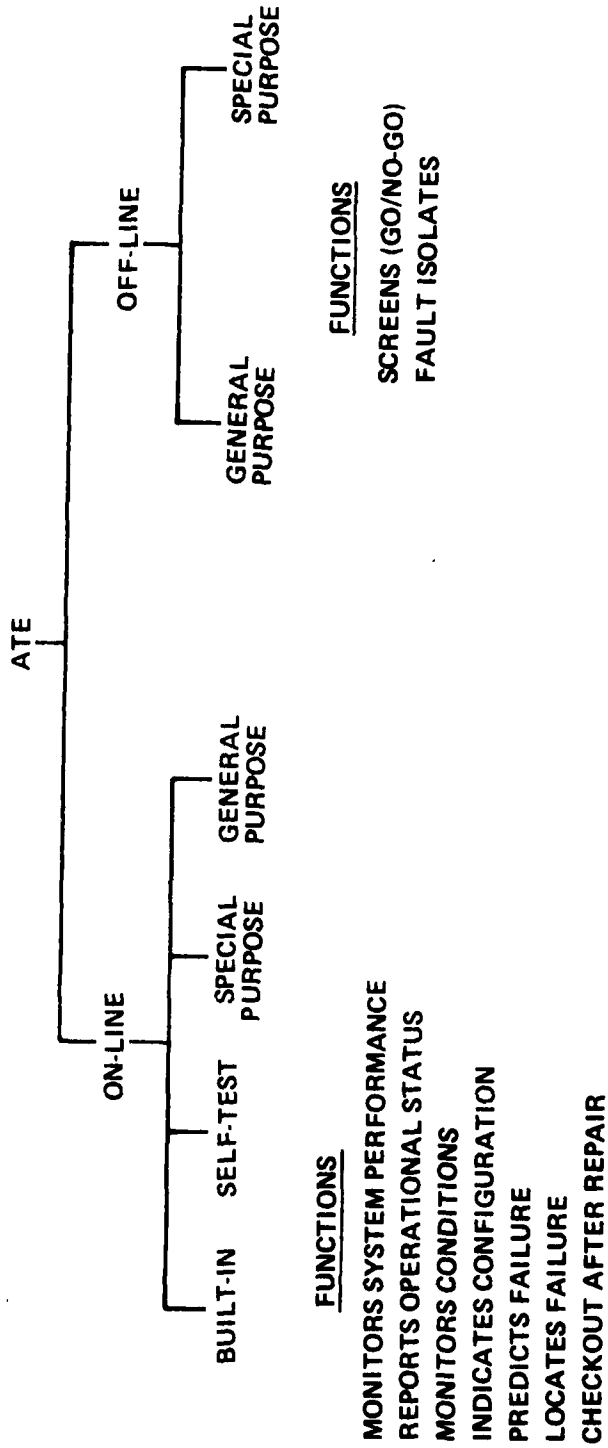

Figure 1-3. Types and Functions of ATE

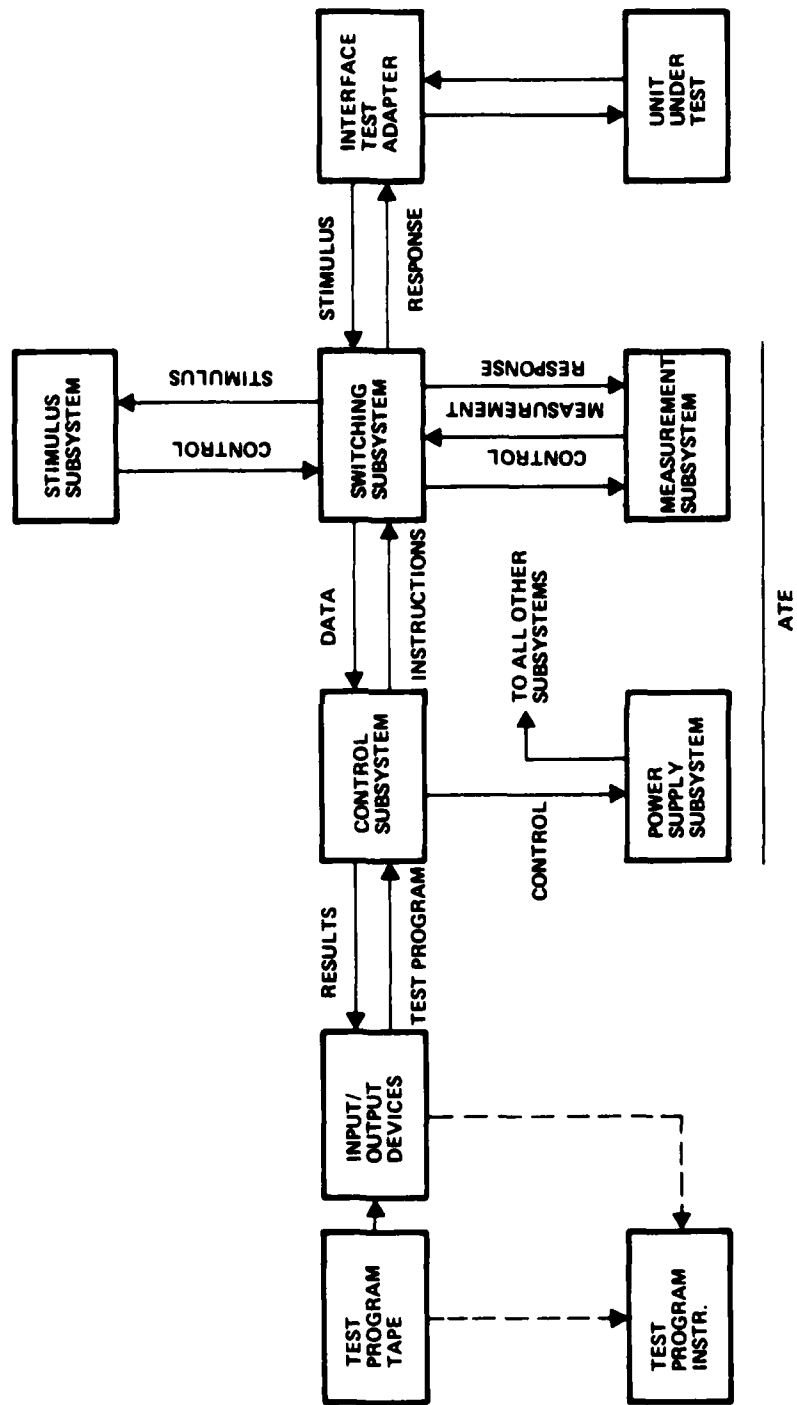

Figure 1-4. Off-line Automatic Test System

Testing complexity can be appreciated when the following situations are considered.

- The UUT may have as many as 200 to 300 input pins.
- Any pin may have at least one stimulus and perhaps more with corresponding measurements of the UUT reactions to the stimulus
- Switching might occur at variable rates up to 50 MHz or greater.
- Multiple ITA's could apply to the same UUT or ATE.
- ITA sophistication may require its own separate processor.
- The type of testing could be analog, digital, or hybrid (a mixture of analog and digital).

An additional consideration of the typical ATE functions is the testing level at which the ATS resides: organizational, intermediate, or depot level. Typically an organizational level ATS will test at an avionics subsystem level with well-defined, inflexible test programs. The test objective at this level is to determine if the avionics system functions and, if not, which LRU is defective. At the intermediate level the testing is accomplished on each LRU with the objective of verifying individual LRU's or isolating fault to the SRU level. Finally, at the depot the test objective is focused on verifying the SRU and to fault isolate at a lower component level. As the ATS are applied from organizational level up to depot the ATE complexity, flexibility, and capability increases. Thus the simpler ATE tester is dispersed to organizational users and the more sophisticated ATE tester resides at the depot.

1.4.1.2 Standard ATE Language

In the late 1960's Aeronautical Radio Inc. (ARINC) developed a test language for commercial airline use. This language is identified as ATLAS which is an acronym for Abbreviated Text Language for All Systems. Since its inception, ATLAS has undergone continuous improvement and development until it is now accepted by all United States services, NATO, DOD, and IEEE as the standard test language.

The principal management advantages of a standard Higher Order Language (HOL) such as ATLAS are;

- Easily readable, simplifies program documentation and program maintenance
- Reduced training requirements
- Reduced programming costs (corporate memory)
- Improved communications between development/manufacturing/test/and maintenance disciplines
- Reduces non-recurring costs related to language development and maintenance

ATLAS is a UUT oriented language as opposed to other languages that are "test system" oriented. This means that ATLAS is test system independent rather than tied to particular testers as a "test system" language would be. The basic elements of ATLAS are:

- It uses fundamental rules of syntax and semantics which integrate the elements into a language
- Input/output features the capability for data to be communicated between the test system and the system operator
- It features data processing capability such as calculations, data storage, program structure, and program control
- It uses a precise set of actions, taken relative to a UUT, such as applying a stimulus, connecting a signal, or making a measurement
- It uses a precise set of electrical mechanical signals which are either applied to the UUT or measured from the UUT.

The last two basic elements primarily distinguish ATLAS from other test languages. ATLAS is not intended as a language for a particular tester, or set of testers. Rather, ATLAS has a primary purpose of specifying tests clearly and unambiguously.

There is some concern that ATLAS is difficult to compile and that a large number of different ATLAS versions exist. ATLAS is a large language which can be applied to analog, digital, or hybrid testing with varying degrees of sophistication. The result is that individual users adopt and compile a subset of ATLAS which applies to their needs only.

Thus many different "configurations" exist but all use the standard language. For a period of several years the ATLAS compilers were error prone and slow; however, within the past few years the ATLAS compilers have become stable and the compilations are no longer as difficult.

The adoption of ATLAS as a standard test language has been compared to the adoption of English as the worldwide standard for international airport traffic controllers. Neither adoption is to say that it is the optimum choice of language but, rather, it is the accepted standard.

1.4.2 Typical ATE System Functions in Engine Testing

Closed loop, computer-controlled testing of overhauled jet aircraft engines is a growing technology within the Air Force. Since the mid-1960's, when automated engine testing was just beginning, the Air Force has continuously pursued the technique within its organization and encouraged computer and test equipment manufacturers to do the same. State-of-the-art technology in computer-controlled engine testing is probably most visible at SA-ALC and OC-ALC. Both ALC's are extensively involved in the testing of overhauled engines.

All aspects of engine test, from preliminary checkout through various manufacturer-specified routines, are under computer control with a system known as Pacer Comet. The system was initiated in 1969 and since then has undergone near continuous improvements. Pacer Comet is used, for example, to test more than 1,000 engines each year at SA-ALC.

Originally each engine type required different software programs, an average of 23, in order to test and measure particular performance and engine operation. Existing test cell equipment and wiring had to be modified or replaced and all subsystems of the process integrated.

As personnel progressed through the various phases of system development, they constantly identified new techniques, software enhancements, and equipment interfaces that would enhance engine throttle control, increase test data reliability, and make additional use of the information.

Now there is a second generation system, Pacer Comet Mark II, that enables one computer to handle four test cells simultaneously while providing additional operating data. Figure 1-5 shows a block diagram of the Pacer Comet Mark II test system.

Pacer Comet provides dramatic results when compared with the manual operation. For example, during the manual-conducted test of a J-79 engine, the operator would move the throttle each time a change in engine speed was required while carefully adhering to manufacturer's specifications and the technical order of the test. Furthermore, the operator would make approximately 700 instrument readings and recordings, 25 chart plots, 150 calculations, and 40 entries to the engine log sheet. For more complex engines these tasks could increase three-fold to the point that even the most experienced operator was inundated with the data. About 40 man-hours of post-test data calculations were required. Pacer Comet enabled these same calculations and more to be available within a few seconds.

Up to four different engine-type tests can be handled simultaneously and asynchronously by a single host computer. Communications between the host and cell systems are supported by a data link, and both systems support CRT's as the primary interface between operator and test cell, and the operator and host computer.

In a typical test, after the operator has entered identification data the computer takes over. It checks all contact points for proper open or closed status, performs a "confidence check" of all wiring and connections, and initiates a "dry start" that pushes air through the engine to check all systems. Then it starts the engine and a series of preliminary tests are made.

The operator "trims" the engine for idle speed and the computer checks oil pressure, exhaust gas temperature, vibration, speed, and bearing-vent pressure and displays the results to the operator. In the

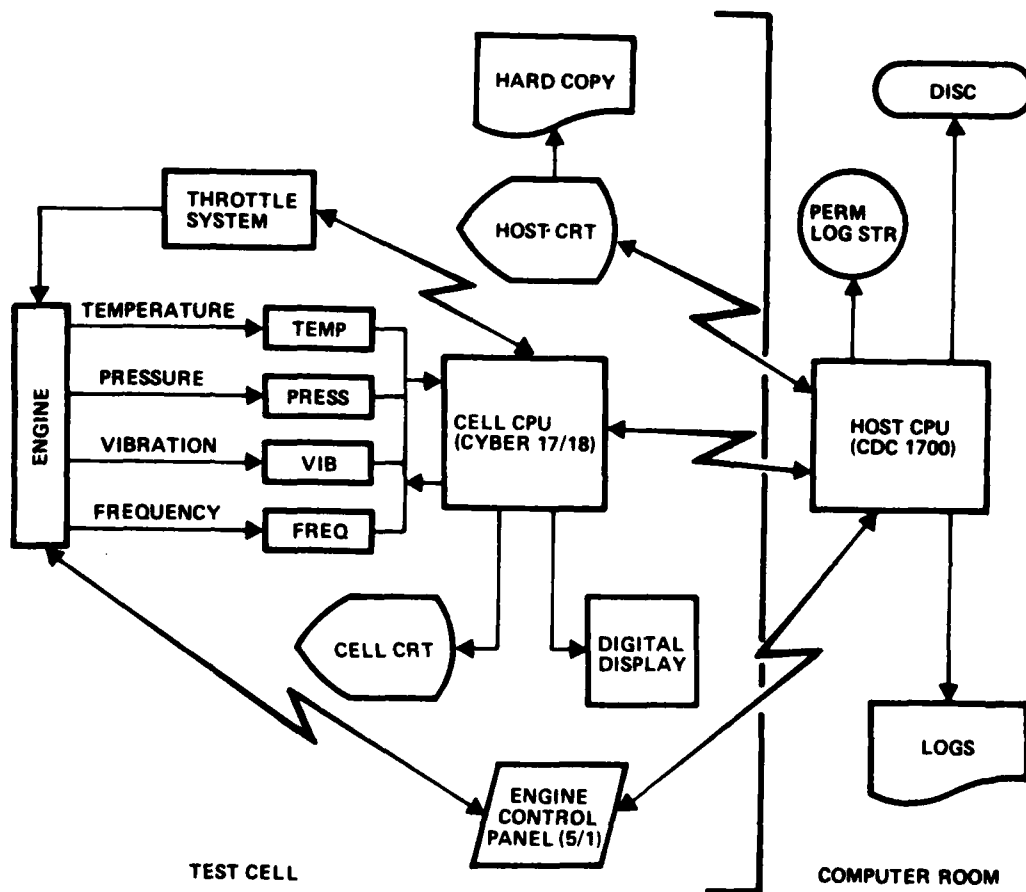

Figure 1-5. Block Diagram of Pacer Comet Mark II Test System

next test phase, the computer checks bleed-valve operation and returns the engine to idle. The computer then activates maximum throttle position and the anti-ice system is checked for possible malfunction.

Next, the engine is run by the computer through a series of acceleration and deceleration phases in both the "primary" and "emergency" fuel control systems, with timed runs made in between for stabilization purposes. To complete the preliminary test, the engine is shut down and mechanics enter the test cell to check for oil and fuel leaks, contamination of strainers and filters, or similar faults.

In the performance runs that follow, more comprehensive checks are made according to a manufacturer-prescribed series of tests. Operating characteristics such as specific fuel consumption resulting from different thrusts and rotor speeds and internal pressure ratios are measured, calculated, and recorded. Normally, three power runs are made between 75 percent of normal rated power and military power. Each of these runs lasts three to five minutes and all data is computer corrected to standard day sea level conditions for proper comparison.

To complete the test, the final shakedown consists of another series of timed runs interspersed with acceleration, deceleration, vibration, and exhaust gas temperature checks, followed by another physical inspection after shutdown.

The system also provides a complete recorded history of the test performed. This includes documentation to support acceptance or rejection of the engine. As test data is accumulated, Pacer Comet provides a diagnostic evaluation of the rejected engine to determine rework requirements and provide for analysis to predict engine trends.

When an engine does not meet all performance requirements, it goes to the "penalty line" where mechanics and machinists make the necessary repairs and adjustments. Then it is completely retested.

An additional mode of testing can be thought of as a subset of engine testing because it addresses the automatic testing of separate engine components. The F100 engine which is used by the F-15 and F-16 aircraft is component and "whole" engine tested. This engine type is used here as an example of engine component testing and the kinds of activities involved.

The F100 engine requires a family of depot level test stands to support maintenance testing, upkeep, and modification implementation on the engine modules and accessories. Associated ATE was selected in conformance with the basic maintenance concept which requires rapid assessment and identification of failure to a single item or component level. Fault corrections are to the piece part level.

The unified control, the engine electronic control, the augmentor spray manifolds, and the air cooled turbine components comprise the F100 engine modules and accessories requiring computer-aided test stands. Each of these is briefly addressed in the following paragraphs.

The F100 engine unified control test stand system is used to perform overhaul performance testing of the complete unified control, or the main section and augmentor section separately, or in any combination of the three as UUT's. These test stands are operated through a Data General NOVA 820 computer using both its own executive and self-test software. The computer has four ports which provide a physical/electrical interface through which any combination of the test stands with appropriate cables, specified port configured computer program, and interface hardware may be configured. The physical configuration can range from one operating test stand with three empty ports to four operating test stands or any intermediary combination.

The F100 engine augmentor spray manifold test stand system is used to verify the performance characteristics of the engine's five augmentor spray manifold assemblies. The system uses a Data General NOVA 820 central computer which can operate up to eight test stands.

Software programs remain unchanged independent of the number of test stands operated; however, additional hardware interface adapters and controllers are required. A manifold configuration change may require software changes; therefore, correlation between the two is maintained via configuration management procedures.

The air cooled turbine component test stand verifies the performance characteristics of the first and second stage turbine rotor blades, and the first and second stage turbine stator vanes. The computer resources existing within this test stand are an embedded FX Systems Mark I calculator and a loadable paper type. The test stand is controlled by the FX Systems Mark I calculator. Although originally lacking a diagnostic capability for the controller, a procurement was made to enable troubleshooting and maintenance of the controller and to acquire several software capabilities.

Only two of the engine electronic control test stands utilize computer resources. These test stands accomplish test, troubleshoot, fault isolate, and simulate operational stimuli. Different test stand configurations exist and each has a distinctly different capability to fault isolate.

1.5 ATE SYSTEM RELATIONSHIP TO ROLES/MISSIONS

The importance of testing is equally as important to the Air Force as the importance of any particular unit under test because it helps the maintenance keep the UUT operative. Testing, whether automatic or manual, serves to verify the UUT is capable of performing the task(s) for which it is intended. UUT's generally are becoming increasingly complex and thousands of tests must be routinely performed on them to verify their operational state. Because manual testing techniques are often impractical due to the nature and number of tests required, some form of automatic testing is necessary.

It has been estimated that automatic test systems account for approximately 75 percent of the total support equipment acquisition costs for the Air Force⁽¹⁾. As an example of the magnitude of ATE costs, the ATE development and acquisition costs for the F-16 are estimated at \$600 million.⁽²⁾ Total ATE inventory costs for AFLC are currently estimated at more than \$10 billion.⁽³⁾ Annual costs for Air Force support equipment have exceeded \$1 billion since 1975 and promise to soar higher (now projected at \$3 billion).⁽⁴⁾ The cost of support equipment, including ATE, is highly significant and warrants constant planning and management attention.

Today's weapon systems, including their avionics subsystems, are complex and their capabilities are crucial to the success of national offensive and defensive strategies. The F-15 is an example of this complexity and Table 1-2 illustrates the number of Interface Test Adapters (ITA's), test programs, and UUT's which are part of the correspondingly complex ATE for this weapon system.

-
- (1) AUTOTESTCON '79 presentation by Capt. Floyd D. Long, Jr., Support Equipment SPO, ASD, WPAFB.
- (2) An Operating and Support Cost Model for Avionics Automatic Test Equipment, Masters Thesis by J. A. Guerra, A. J. Lesko and J. G. Pereira.
- (3) Informal discussions at San Antonio ALC, May 1980.
- (4) Industry/Joint Services Automatic Test Project Executive Summary, December 1979.

Table 1-2. F-15 ATE ITA/TP/UUT Overview†

ATE Station	ITA's	Test Programs	UUT's/WUC
HIADTS Digital	53	217	130
Analog	61	322	154
IF/VM	24	64	22
HPADTS	TBD	TBD	22
Multifunction	17	63	51
COMETS Digital	8	24	31
INS (Litton)	31	32	32
AAI 5500	5	7	7
TEWS Depot	TBD	TBD	100
AIS Computer	28	45	29
AIS Displays	12	39	12
AIS Microwave	5	19	5
TITE	TBD	24	24
AIS AGE			
Kelly Microwave	100	123	123
Power Supply	56	97	97
GEN RAD 1792D/1096	42	165	165
COMETS AGE	TBD	359	377

† Reference data only; subject to change throughout life cycle of F-15.

Generically, automatic testing serves to:

- Verify the components of weapon systems
- Provide fault isolation of component discrepancies
- Minimize spare levels by quickly indicating faults and expediting repair activities
- Reduce the demand for highly trained technicians

Automatic testing is growing in costs and importance to the Air Force. Increased attention must be paid to existing policies, procedures, planning, and management to ensure that weapon systems operationally function as required and that ATE is not in any way a deterrent to weapon system availability.

2. ATE SUPPORT REQUIREMENTS

Automatic test equipment provides support to a wide variety of Air Force weapon systems and to their components. The automatic testing can be of a nature to check software and/or hardware of the weapon systems or even to check the ATE itself. As mentioned earlier in this document there are two types of ATE testing, on-line and off-line. Either type requires support; this section addresses support requirements as they generally apply to both types. The generic requirements of change, change analysis and specification, engineering development and unit test, system integration and test, change documentation, and certification and distribution apply to ATE as well as to all other ECS categories. Table 2-1 summarizes the remarks on each support requirement.

2.1 ECS CHANGE

2.1.1 Receive and Process Requests

Changes to ATE or ATE software can be of a hardware component, test program, control program, or support program nature. Changes to ATE hardware occur because of technology improvement or to overcome a test limitation. Software changes most commonly occur to the UUT test programs because of their lack of testing depth or inaccurate testing; however, changes can occur to the ATE's control and support software programs. Discovery of the need for change may be made at the depot, intermediate, or organizational testing levels. Change notification is usually made via a Material Deficiency Report (MDR) submitted to the UUT item manager or to the ATE system manager; however, a change notification may also result from an Engineering Change Proposal (ECP) to modify the weapon system design.

Table 2-1. ATE System Support Requirements

ATE Change Requirement	Remarks
<p>ECSC Change</p> <ul style="list-style-type: none"> ● Receive and Process Requests ● Preliminary Analysis and Problem/Deficiency Definition ● Preliminary Resource Allocation and Scheduling <p>Change Analysis and Specification</p> <ul style="list-style-type: none"> ● Feasibility ● Requirements Decomposition/Definition ● Preliminary Design ● Detailed Design ● Generate Change Proposal 	<ul style="list-style-type: none"> ● Change requests normally apply to UUT test programs; however, hardware, control software, and support software changes are possible. A common process tracks ATE changes as well as changes to weapon systems (i.e., the MDR process). Change requests occur at all three testing levels: organizational, intermediate, and depot. ● An engineering analysis of the change request is begun and change control procedures are initiated. ● Change priority is established. Resources are identified to accomplish the change. A preliminary schedule is prepared. ● This activity accomplishes trade-offs to establish the cost effectiveness of the change, its implications to the existent system baseline, and the timeliness of the change. ● Resource requirements are detailed into work packages and tasks. ● Alternative designs are considered and the most promising one is selected. ● This activity establishes the means of development and technical verification. ● This step formalizes its work package for organic or contractor accomplishment.

Table 2-1. ATE System Support Requirements (Concluded)

ATE Change Requirement	Remarks
Engineering Development and Unit Test	
<ul style="list-style-type: none"> • Develop the Change 	<ul style="list-style-type: none"> • This activity converts the change design into code and/or hardware amendments to the system. Normal development practices apply.
<ul style="list-style-type: none"> • Perform Engineering Tests 	<ul style="list-style-type: none"> • Units of work are separately tested to ensure the technical functions of the change are valid, functioning, and not a problem to the rest of the ATE.
System Integration and Test	
<ul style="list-style-type: none"> • Test ATE System Performance 	<ul style="list-style-type: none"> • This step establishes confidence in the revised ATE system.
<ul style="list-style-type: none"> • Test Weapon System Performance 	<ul style="list-style-type: none"> • Not applicable to ATE.
<ul style="list-style-type: none"> • Produce Test Results 	<ul style="list-style-type: none"> • Publish data for subsequent analysis and conclusion.
Change Documentation	
<ul style="list-style-type: none"> • Document ATE Change 	<ul style="list-style-type: none"> • Document the entire ATE change in source form.
<ul style="list-style-type: none"> • Update ATE Baseline 	<ul style="list-style-type: none"> • Update the ATE baseline to include the change just accomplished.
<ul style="list-style-type: none"> • Configuration Control 	<ul style="list-style-type: none"> • Control the trial and final versions of documentation so that incremental progress is benchmarked.
Certification and Distribution	
<ul style="list-style-type: none"> • Certify Documentation 	<ul style="list-style-type: none"> • Administratively recognize the revised baseline documentation.
<ul style="list-style-type: none"> • Distribute Revised ATE System Data 	<ul style="list-style-type: none"> • This applies to multiple users of the same ATE systems.
<ul style="list-style-type: none"> • Provide Installation Procedures/Instructions 	<ul style="list-style-type: none"> • Publish and distribute installation procedures and/or instructions. Dispatch technical assistance to user locations, if necessary

2.1.2 Preliminary Analysis and Problem/Deficiency Definition

Upon receipt of the ATE change request, the responsible agency initiates change control procedures and an engineering analysis of the change. Preliminary analysis of any impact to existing capabilities is accomplished. If no abortive type impacts are recognized, the technical change to the ATE is defined.

2.1.3 Preliminary Resource Allocation and Scheduling

A relative priority of the ATE change versus other change requests is established. For all accepted changes the responsible agency ensures that resources involving organic and/or contractor sources are allocated and a preliminary schedule for completion is published.

2.2 CHANGE ANALYSIS AND SPECIFICATION

2.2.1 Establish Change Feasibility

Feasibility is determined by assessing if the impacts to the existing system are worth the penalties to incorporate the change. In most ATE cases the feasibility is established by this time since the change may only necessitate an additional test sequence or a new set of input stimuli.

2.2.2 Requirements Decomposition/Definition

For simple changes this step would have been completed by satisfying the requirement discussed in paragraph 2.1.2. But for hardware or control/support software changes it may be necessary to break the development task into discrete work packages and a well-defined design approach.

2.2.3 Preliminary Design

For major changes, alternative designs may be conceived and analyzed for selection of the most promising approach.

2.2.4 Detailed Design

This activity selects a design approach, establishes the means of development and technical verification, and identifies problems and procedures.

2.2.5 Generate Change Proposal

When the task solution is ready for formal approval, a work package is developed and locally approved.

2.3 ENGINEERING DEVELOPMENT AND UNIT TEST

2.3.1 Develop the Change

The change proposal is accomplished through use of separate or composite in-house and contractor resources. These resources are spread across the spectrum of work packages and normal development practices are applied.

2.3.2 Perform Engineering Tests

All work units of hardware and/or software are separately tested during development to verify the desired technical functions of the changes are working, the engineering integrity of the programs are valid, and no unusual or problem areas persist with the change.

2.4 SYSTEM INTEGRATION AND TEST

2.4.1 Test ATE System Performance

Testing of the ATE after incorporation of the change is necessary to get a measure of confidence the revised ATE system performs as desired and without impacting previously established capability.

2.4.2 Test Weapon System Performance

This specific requirement does not apply to ATE.

2.4.3 Produce Test Results

Subsequent to test completion, sufficient data for analysis and test results are compiled and published in written format.

2.5 CHANGE DOCUMENTATION

2.5.1 Document ATE Changes

All working documents must be updated to provide a valid working baseline for reference material for further support.

2.5.2 Update ATE Baseline

Update all baseline documentation to include hardware drawings, associated software descriptions, and any pertinent procedural changes.

2.5.3 Configuration Control

Throughout the final stages of developing and testing, the various trial and final versions must be rigidly controlled so that incremental progress is benchmarked and catastrophic failure will not occur.

2.6 CERTIFICATION AND DISTRIBUTION

2.6.1 Certify Documentation

This is an administrative function to recognize the revised ATE and its baseline description.

2.6.2 Distribute Revised ATE System Data

This is a requirement for multi-user ATE for which the ATE applies commonly to different avionic systems.

2.6.3 Provide Installation Procedures/Instructions

This may be a requirement if the hardware change is significantly complex or if the system change necessitates new operating procedures.

3. ATE SUPPORT CONCEPT DESCRIPTION

Support for ATE systems is generally organically accomplished by AFLC using all five Air Logistics Centers and the Aerospace Guidance and Metrology Center (AGMC) to provide various aspects of the support. Certain ATE support may require contractor resources whose overall activities are AFLC-managed after PMRT, but typically are managed by AFSC prior to PMRT. Discussions in this section will address the logistics management, organizational, and system change portions of the ATE support concept.

3.1 MANAGEMENT CONCEPT

AFLCR 523-1 establishes policy governing mission assignments to all AFLC activities. Using general criteria such as existing investment in skills and facilities, technical/management skills, workload balance, etc., each ALC is assigned specific management tasks. Management of ATE is assigned in accordance with AFLCR 523-1 and new ATE entering the inventory is normally assigned to the ATE SM. The associated support software is assigned with the ATE management assignment and supported in accordance with AFLCR 66-27. ATE control software is managed with the tester. The ATE equipment and its support and control software are generally assigned to San Antonio ALC for management. This assignment is depicted in Figure 3-1 as the portion of the automatic test system that is outlined with the heavy solid lines and labelled automatic test equipment.

ATE test software (UUT test program) is managed by the UUT manager who may be located at any ALC and who manages the software in accordance with the Computer Program Configuration Item (CPCI)

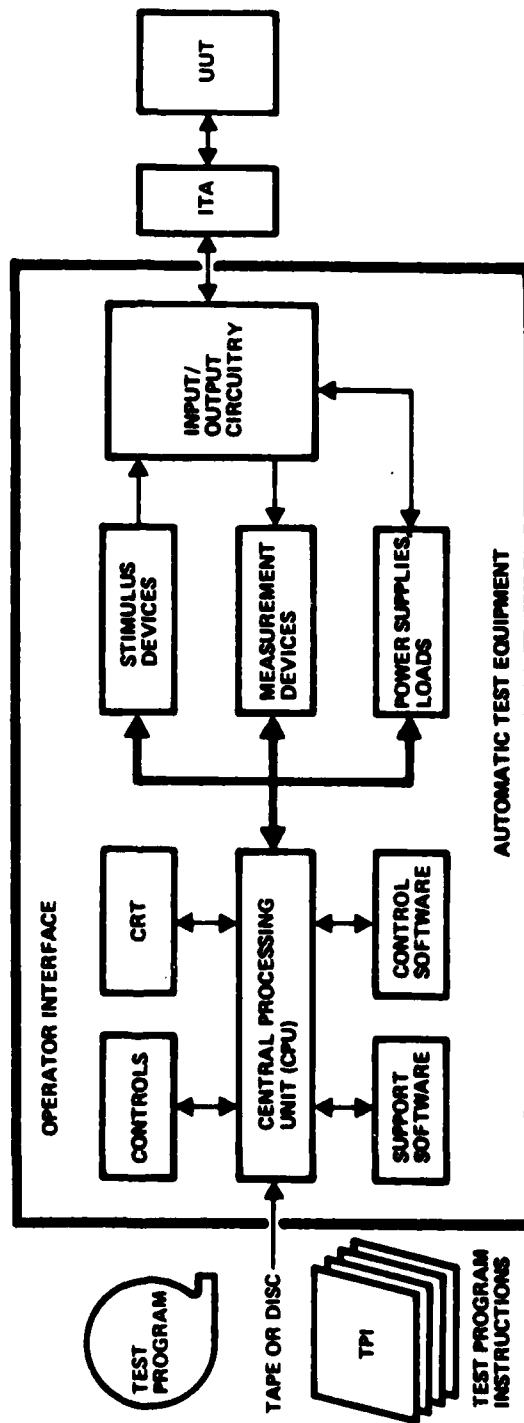

Figure 3-1. Automatic Test System (ATE SM Assignment)

procedures outlined by AFR 800-14. Rapid deficiency resolution may necessitate a deviation from the CPCI control route. All UUT software changes/implementations are required to be coordinated with the assigned ATE manager if the hardware is impacted.

Interface Test Adapters (ITA) are also managed by the UUT manager unless: (a) the equipment is purchased to provide a general purpose capability for the tester or (b) an ITA (not excepted by (a)) is used in testing UUT's assigned to two or more IM/SM divisions. The UUT manager responsibility items are indicated by the heavily lined boxes in Figure 3-2.

Many of the computers and peripheral equipment used within ATE are federally stock classed as FSG-70 which is the management responsibility of WR-ALC Item Management Division (MMI). In many cases this responsibility includes some or all of the support and control software. The heavily lined box shown in Figure 3-3 indicates this assignment responsibility and the FSG-70 manager's role in this regard is not generally recognized.

AGMC is assigned the responsibility to determine requirements for and accomplish equipment calibration support.

Tables 3-1 and 3-2 use the F-15 situation as an example to illustrate the application of the ATE management concept. These tables should not be construed as entirely describing the F-15 management assignment situation, but only a portion of that assignment.

Table 3-1 shows the AFLC location of each ATE station and the approximate quantities of UUT's tested on each station managed by each ALC.

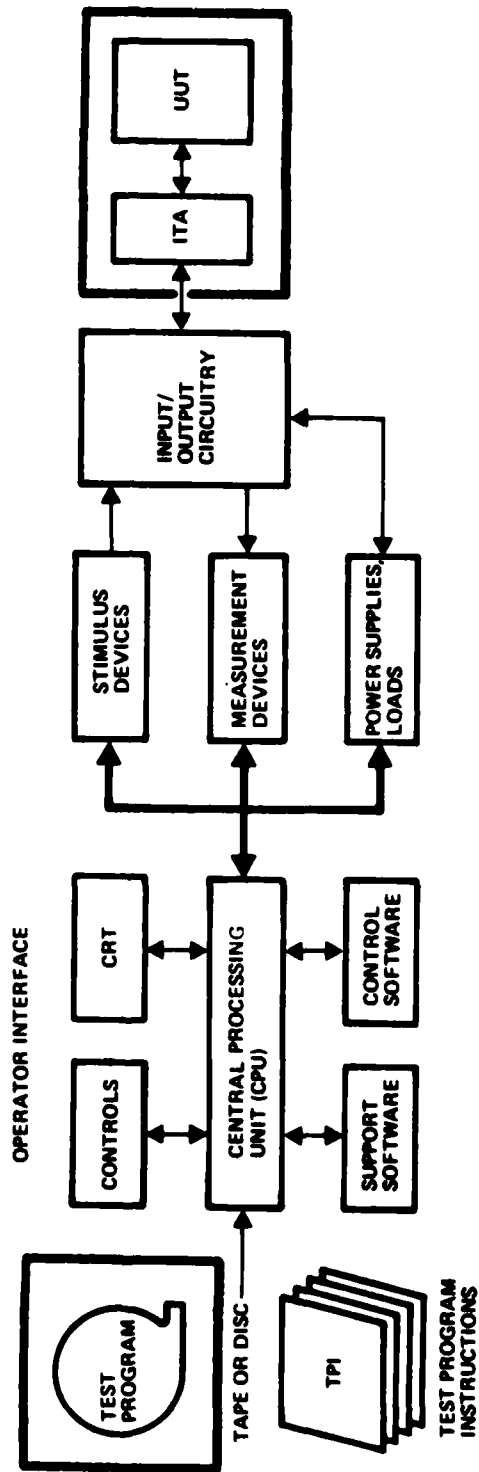

Figure 3-2. Automatic Test System (UUT Manager Assignment)

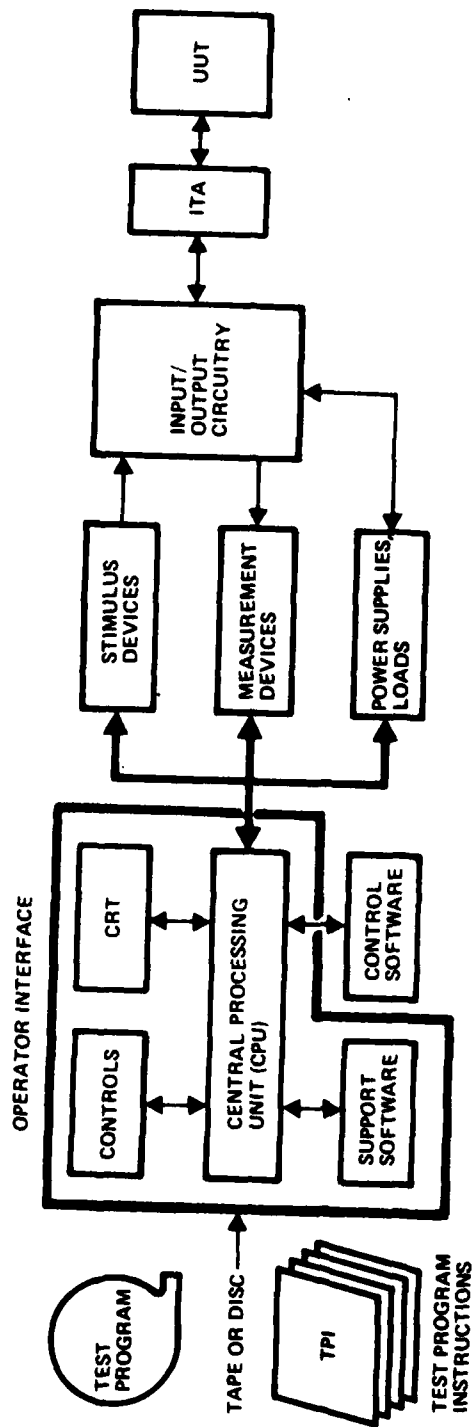

Figure 3-3. Automatic Test System (FSG-70 Assignment)

Table 3-1. F-15 UUT/WUC Distribution

ATE Location/ATE Station	Item Manager ALC					
	Warner Robins	Sacramento	Ogden	Oklahoma City	San Antonio	
Warner Robins ALC						
Computer (AIS)	1			23	4	
Displays (AIS)	5		1	6		
Microwave (AIS)	5					
Analog (ADTS)	73	4		8		
Digital (ADTS)	98			4		
IF-Video/MW (ADTS)	20	4				
TEWS Intermediate	27					
TEWS Depot	100					
Sacramento ALC						
Analog (ADTS)	2	4		16	16	
Multifunction				51		
Oklahoma City ALC						
Analog (ADTS)				19		
Ogden ALC						
Analog (ADTS)	12			2		
Digital (ADTS)	23			4		
Digital (COMETS)	6		5	20	5	
AAI 5500						
AGMC						
INS (ADTS)				32		
San Antonio ALC						
AGE Module (6861)						379
Kelly Microwave						140
Power Supply						109
GEN RAD 1792/1796						184

Table 3-2. F-15 ATE Distribution by ALC

Warner Robins	Sacramento	Oklahoma City	Ogden	AGMC	San Antonio
AIS					
Computer Displays Microwave					
Honeywell ADTS					
Analog	Analog	Analog	Analog		
Digital			Digital		
IF - Video/MW					
TEWS Intermediate	Multifunction				
TEWS Depot			66FC AAI 5500		
HP ADTS				Litton Ins	6861 Kelly Micro-wave Power Supply GEN RAD 1792D/1796

Table 3-2 shows the distribution of ATE stations by ALC as results from technical repair center assignment. Associated with each station is a set of control and self-test software. Management of this software is the responsibility of the ATE SM typically located at SA-ALC.

3.1.1 Management Concept Assessment

Management relationships of the ATE responsible agencies are closely interrelated and complex. The examples given in this section have illustrated the complexities associated with the F-15 weapon system only. When all other weapon systems are overlayed together, the complexity of any particular ALC or of them all is intricate. Exceptions also compound the complexity when certain weapon systems necessitate separation of their unique ATE from the normal management assignment mechanisms.

The current ATE management concept provides ample visibility of items and systems although the overall management problems are complex. The interrelationships of the item and system assignments mask grass root causes of any management problems. Thus the rectification of problems becomes subtle to conceive and implement.

3.2 LOGISTICS SUPPORT CONCEPT

AFLC exerts influence on automatic test system acquisition to ensure that logistics support of each element of the ATS is accounted for, from the beginning of the weapon system conceptual phase through the operational application. The concept requires the following. The assigned ATE SM is responsible for planning the transition of the ATE from the acquisition agency to AFLC; the UUT managers are responsible for Test Requirements Documents (TRD), back-up source data, ITA's, and the UUT test programs for their assigned UUT's; and spare and repair quantities are indicated through use of the standard automated data systems used by AFLC. The FSG-70 manager (WR-ALC/MMI) is responsible for logistics support of the ATS general purpose computer and peripherals.

3.3 ATE SOFTWARE CHANGE PROCESS/CONCEPT

The ATE change process is quite intricate to describe. Consequently, this section is structured to provide rationale for ATE software changes and then a description of the change process used.

3.3.1 ATE Software Changes

Changes to ATE can involve digital, analog, or hybrid functional testing accomplished through built-in-test, self-test, diagnostic tests, fault isolation, ATE control software, ATE support software, or the UUT test programs. Categorically, changes to ATE occur because of a few basic reasons: the ATE incorrectly tests, the ATE doesn't test to the extent it should or the ATE overtests (consistently indicates failures when none exist). Thus it is appropriate that automatic testing be briefly discussed prior to discussing ATE changes.

Generally, automatic testing is either of a functional or a diagnostic nature. Functionally testing a UUT simply determines if the UUT operates correctly. This is accomplished by applying a variety of input stimuli to the UUT and observing or measuring the UUT responses to the stimuli. As the test program steps the UUT through its logic states, the responses are compared against correct responses. As long as the responses match (measured response against the expected or known response) the UUT is passing. If a mismatch occurs, the UUT indicates a failure and must be repaired. Certain UUT's require testing at normal UUT operating speed which means the input stimuli must occur at that rate (dynamic testing). Other UUT's can be meaningfully tested at a relatively slow rate compared to normal UUT operation (static testing). In either static or dynamic testing the sole purpose of functional testing is to verify the UUT operational state.

Assuming a functional failure of the UUT, diagnostic information must be provided to assist the repair agency in determining the deficient area (fault isolation) of the UUT so repairs can be accomplished. There are two techniques that are commonly used in fault isolation, fault dictionary lookup and computer guided probe.

A fault dictionary contains hundreds of response patterns that are a result of intentionally inserted faults. If a match occurs between the test situation and one of the patterns, then this indicates a failed component and thus isolates the fault. It is possible to see that all of the possible fault patterns (signatures) for a UUT may not be contained in the dictionary. It may be necessary to introduce more fault patterns to adequately check the UUT (a UUT test program change). The advantage of fault dictionary lookup diagnosis is that no operator interaction is necessary during the test and the process is fast. A disadvantage is the dictionary is inherently incomplete and limited in fault isolation by the circuit topology (complexity and layout). Sometimes the results provide inaccurate or redundant fault isolation indications.

A computer guided probe does not depend on stored data of faulty UUT responses. It uses data of a properly functioning UUT and compares it to data read by the probe. A mismatch means the probed area is faulty. Diagnostic accuracy using the probe is much better than the fault dictionary method, but the probe is operator dependent and therefore slow and prone to human error. Additionally, the existence of numerous feedback loops can limit the computer to the diagnosis of many modes, rather than one, and intermittent faults are not always detected. These shortcomings can prompt computer program changes.

Perhaps the most promising approach for future ATE systems is a combination of fault dictionary and an interactive computer probe. Complementing the fault dictionary, probing improves problem resolution when the dictionary approach cannot isolate to a single mode.

UUT's may typically contain from 20 to 200 input pins with many, many circuits on a card. Exhaustive testing is impractical, if not impossible, thus a means of generating only the most meaningful input stimuli is required. Automatic Test Pattern Generators (ATPG) are used as a technique whereby the ATPG system software generates UUT test input stimuli based upon an interpretation of the logic contained within the UUT. No ATPG can claim to generate tests for every possible

UUT circuit, and sometimes the UUT performs in a manner that bypasses the testing extent of the ATPG stimuli. Identification of such a test omission necessitates a UUT test program change. ATPG systems provide the test programmer with varying degrees of aid depending on the UUT circuit nature and complexity. Table 3-3 is included as an example of the number of ATPG's that can apply to a weapon system and its associated ATE. In this case the weapon system is the F-15.

As can be seen from the discussion to this point, many factors can cause ATE software changes. The changes occur primarily because the test programs are not perfectly developed. When software changes are required the algorithms involved are not generally classified as technically complex, although certain exceptions exist such as a test to exercise a complex curve fitting algorithm. The difficulty comes primarily from isolating the single fix point from such a myriad of possibilities.

Hardware changes can occur, for example, when a measurement tool is not fast enough or the interface test adapter does not properly link the ATE and the UUT. In many cases it is prevalent and easier to make changes to the ITA in lieu of the ATE. Such actions complicate the ITA and in certain instances the ITA demands an internal processor. Hardware changes are of direct interest to this study only when they require or influence ATE software changes.

The largest single cause of ATE software changes occurs because of incomplete UUT test programs. Incompleteness is caused primarily by inadequate Test Requirements Documents (TRD's) or a failure of the acquisition agency to implement adequate TRD's with the weapon system acquisition. This situation is so rampant that approximately 25 to 40 percent of the UUT test programs will not function when initially received at the Technical Repair Center (TRC) at WR-ALC and 75 to 90 percent of the test programs require major modification within two years after TRC receipt. Additionally, software changes are often required because of incomplete development by the weapon system contractor or the test program contractor. The inadequate TRD situation is further addressed in Section 5 of this report.

Table 3-3. Automatic Test Pattern Generators
For F-15 ATE

ATE Family	ATPG Name or Owning Contractors	No. of UUT's
Honeywell ADTS	IBM ATPG	7
	Honeywell (HI-FADS)	5
Digital	Hughes SATGEN	46
	Texas Instruments TI-ATPG	20
COMETS Digital - 66FC	LASAR (Navy Version)	5
COMETS - 6861	Bendix ATPG/MCAIR	56
TEWS Depot Station	Test Aids III	45
HP ADTS	Test Aids III	14

AFLCR 66-37 lists five principal activities associated with any ATE system, any one of which represents a possible source of ATE software change. They are the user, UUT manager, ATE IM/SM, ATE software support center, and data automation. The user refers to the actual ATE using agency. Depending upon the level of testing involved the user could be a TRC, a TAC maintenance group, or one of many other agencies. The UUT manager is that person who has the responsibility for ensuring that the UUT is kept serviceable and operational. This person may be an item manager or a system manager located at any ALC. An item manager or system manager of an ATE is responsible for the ATE elements in the same manner as is the UUT manager for the UUT. Each ALC and AGMC has a Software Support Center (SSC) assigned to the maintenance directorate to act as the focal point for the processing of ATE software and for support of assigned ATS. Data automation provides support for off-line Automatic Data Processing Equipment (ADPE) such as the Remote Job Entry Terminal (RJET). Table 3-4 indicates an example of off-line support for the F-15 that ATE supplies through RJET from Ogden.

Any of the aforementioned activities may discover the need for amending ATE software and initiate processing of the change. In addition, AGMC has a software support center which maintains an organic capability to prepare and correct calibration test software used to calibrate precision measuring equipment.

3.3.2 Engine and Component Testing Concept

As indicated in Section 1.4.2, testing of engines within AFLC is done at both OC-ALC and SA-ALC. Both sites use the Pacer Comet system to test engines in a completely assembled condition primarily as a result of returning the engines to the depot for scheduled maintenance or overhaul. The overall AFLC engine test workload is split so that certain types of engines are tested only at one site; e.g., the F100 engine is tested at SA-ALC while TF33 is tested at OC-ALC. If an engine is

Table 3-4. Off-Line ATE Software Support Requirements

Software Element	Requirement
F-15 Adapted PLACE ATLAS (FAPA) Compiler/Mini-FAPA Compiler	LRU test program generation test procedures manuals status log manipulation
MAGIC BETA Compiler	Module test program generation compiler change support
MAC Compiler	Module test program generation
LASAR ATPG (G2)	Digital test pattern generation
ATPG (TBD)	Digital test pattern generation

disassembled at the depot (such as would occur during overhaul) the modules or components of the engine are separately tested and finally, upon complete engine reassembly, the entire engine is tested.

Although most complete and/or component engine testing is accomplished at the depot level there are certain tests conducted at field levels. Automatic trim testing is an example of this. All engine test set/operator combinations must perform certain basic tasks:

- Measure engine data
- Monitor values of data against engine safety limits
- Reduce the data to a useable form, i. e., engineering units
- Compute standard day correction, etc.
- Display the data
- Compare the displayed values against trim or performance curves
- Determine correction action for out-of-limits conditions
- Record data and test results
- Provide data and test results to all interested agencies

Engine trim systems accomplish part of all of these tasks (depending upon trim system sophistication) in an automatic mode. The overall objective of trim testing is to minimize cost and safety risks. This type of testing can be envisioned as a final alignment for a particular aircraft, geographic location, and/or mission usage.

Engine component testing began to use the concept of "On-Condition Maintenance" (OCM) in 1977. Primarily, this type of testing uses a building block approach in reassembly of the engine modules. Modules are broken down to the lowest component levels and the components pooled in bins. Reassembly of the module does not necessarily use the

same combination of components and when the initial components are assembled the assembly is tested at this level. Satisfactory testing means that more components can be added and then at that level be tested "on the condition" that the lower subassembly meets testing requirements. The process then continues until the engine modules are completely assembled. Several portions of the testing are controlled automatically or semi-automatically with computers.

Interviews with maintenance personnel indicate that the outcome of using these engine test approaches provides very favorable results. Pacer Comet usage sharply reduces the number of testing personnel from a comparable manual testing level, decreases total test time, and improves fault diagnosis and isolation. Trim testing provides increased assurance that the engine is favorably matched to its environment and thus enhances safety considerations. OCM results in improved testing results and decreased testing time for the engine modules.

3.3.3 Change Forms and Procedures

Previous discussion indicated why ATE software often needs change and the likely "discoverers" for any changes were identified. This section addresses the mechanisms by which changes are processed.

Materiel Deficiency Reports (MDR's) provide a system to feed back deficiency data on hardware and/or computer programs to activities responsible for the development, acquisition, and other logistics management functions. MDR's allow action to be taken to correct and prevent materiel, design, and quality deficiencies.

There are two types of MDR's, Category I and Category II. A Category I MDR is a report of an emergency condition on all types of equipment, systems, and computer program which presents, or has the clear potential to present, an unacceptable safety hazard. Computer programs which prevent equipment usage, may cause Air Force mishaps, etc., can be reported by Category I MDR. Category II MDR's report

quality deficiencies in materials. Either category can be used to report an ATE deficiency and the urgency of processing the change dictates which category to use. Ultimately the MDR is sent to the SM or IM who is responsible for the computer programs and documentation.

AFR 800-14 and associated AFLC supplements require computer program deficiencies be identified by and processed as MDR's in accordance with Technical Order (T.O.) 00-35D-54. This supercedes use of both AFTO Form 22 and Quality Deficiency Reports (QDR's) although AFSC still uses QDR's. Deficiencies are resolved by Materiel Improvement Project (MIP) action in accordance with T.O. 00-5-15 and AFLCR 66-15. Distribution of computer program changes are accomplished by Time Compliance Technical Order (TCTO) in accordance with T.O. 00-5-15, AFR 57-4, and AFLCR 66-14.

In most cases MDR's are received, processed, and distributed on a one-to-one basis, i. e., one MIP and one TCTO for each MDR received. Each ALC has a focal point (usually MMMS) where all externally generated MDR's are sent. MMMS screens them and the ATE MDR's are sent to the appropriate item or system manager. The flow chart in Figure 3-4 is indicative of the complex administrative data flow the MDR/MIP/TCTO process implements. This particular flow exists at San Antonio ALC.

It is important to know that UUT software or test program MDR's can be submitted from either the organizational, intermediate, or depot testing levels. UUT MDR's normally precede the submission of an ATE MDR because any ATE deficiency is likely discovered while attempting to test or diagnose a UUT. Any identified ATE deficiency would likely be revealed because the tester is not portraying an accurate analysis of the UUT operational state.

3.3.4 Change Process Assessment

Administratively the change process is complex. T.O. 00-35D-54, controls the way that ATE software changes are processed. Command/directorate organizational structures and mission assignment policies

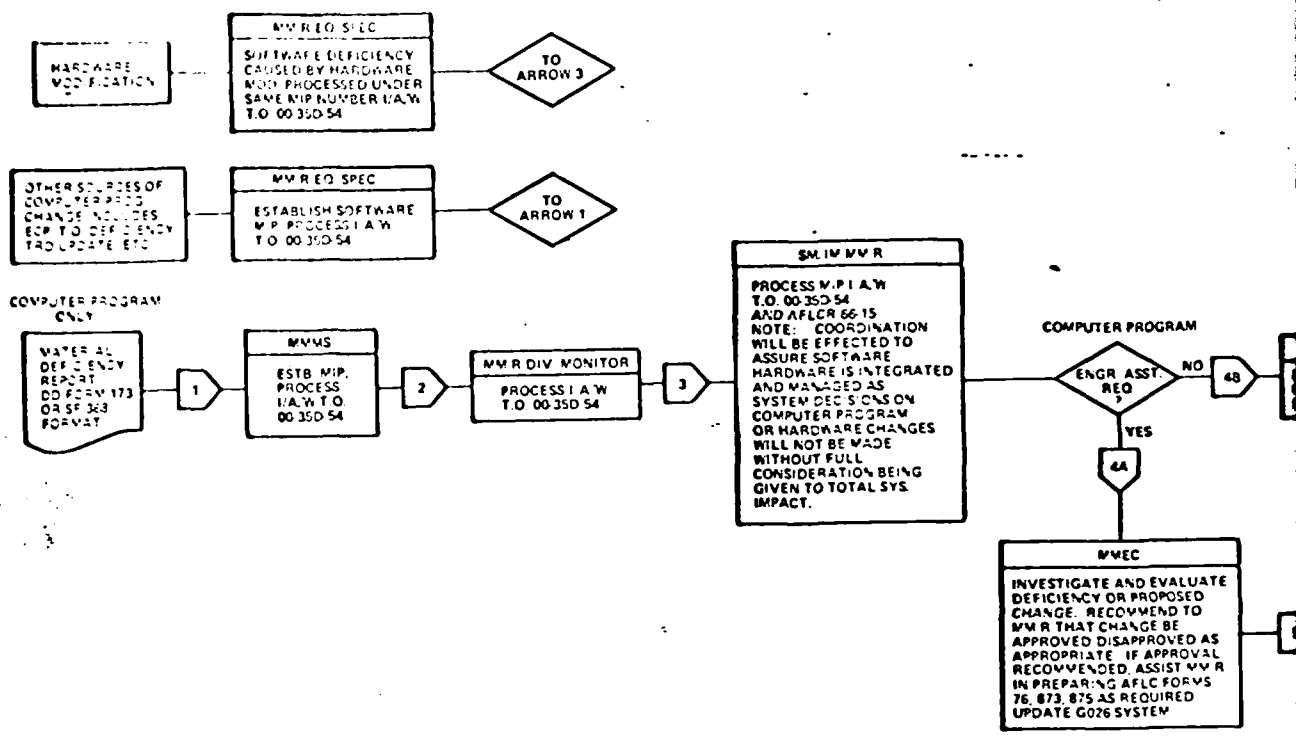

HARDWARE MODIFICATION

MMR REQ SPEC
SOFTWARE DEFICIENCY CAUSED BY HARDWARE MOD.
PROCESSED UNDER SAME M/P NUMBER I/A/W
T.O. 00 35D 54

TO ARROW 3

OTHER SOURCES OF COMPUTER DEFICIENCY
CHANGE REQUESTS EGP TO DEFICIENCY
TROUBLESHOOTING ETC.

MMR REQ SPEC
ESTABLISH SOFTWARE M/P PROCESS I/A/W
T.O. 00 35D 54

TO ARROW 1

COMPUTER PROGRAM ONLY

MATERIAL DEFICIENCY REPORT
DD FORM 173 OR SF 363
FORMAT

1

MMMS
ESTB M/P PROCESS I/A/W T.O.
00 35D 54

2

MMR DIV MONITOR
PROCESS I/A/W T.O. 00 35D 54

3

SMIMMR
PROCESS M/P I/A/W T.O. 00 35D 54
AND AFCLR 66-15
NOTE: COORDINATION WILL BE EFFECTED TO
ASSURE SOFTWARE HARDWARE IS INTEGRATED
AND MANAGED AS SYSTEM DECISIONS ON
COMPUTER PROGRAM OR HARDWARE CHANGES
WILL NOT BE MADE WITHOUT FULL
CONSIDERATION BEING GIVEN TO TOTAL SYS.
IMPACT.

COMPUTER PROGRAM

ENGR ASST. REQ.

NO

4B

YES

4A

MMEC
INVESTIGATE AND EVALUATE DEFICIENCY OR
PROPOSED CHANGE. RECOMMEND TO MMR THAT
CHANGE BE APPROVED DISAPPROVED AS
APPROPRIATE IF APPROVAL RECOMMENDED,
ASSIST MMR IN PREPARING AFCL FORMS 76,
873, 875 AS REQUIRED UPDATE G076 SYSTEM

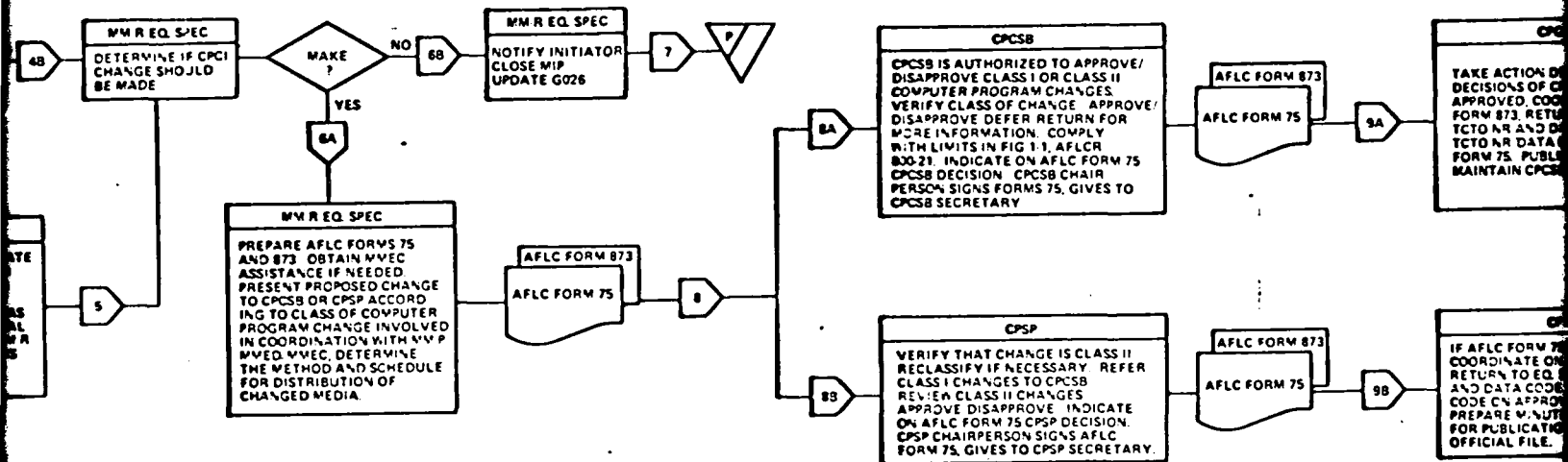

2

CPCS8 SECY

TAKE ACTION DEPENDING ON DECISIONS OF CPCS8. IF FORM 75 APPROVED, COORDINATE ON AFLC FORM 873. RETURN TO EQ SPEC FOR TCTO NR AND DATA CODE. ENTER TCTO NR DATA CODE ON APPROVED FORM 75. PUBLISH DISTRB MINUTES. MAINTAIN CPCS8 CPCS8 OFFICIAL FILES.

CPCS8 SECY

IF AFLC FORM 75 IS APPROVED COORDINATE ON AFLC FORM 873. RETURN TO EQ SPEC FOR TCTO NR, MEER AND DATA CODE. ENTER TCTO NR DATA CODE ON APPROVED AFLC FORM 75. PREPARE MINUTES. SEND TO CPCS8 SECY FOR PUBLICATION DISTRB AND FOR OFFICIAL FILE.

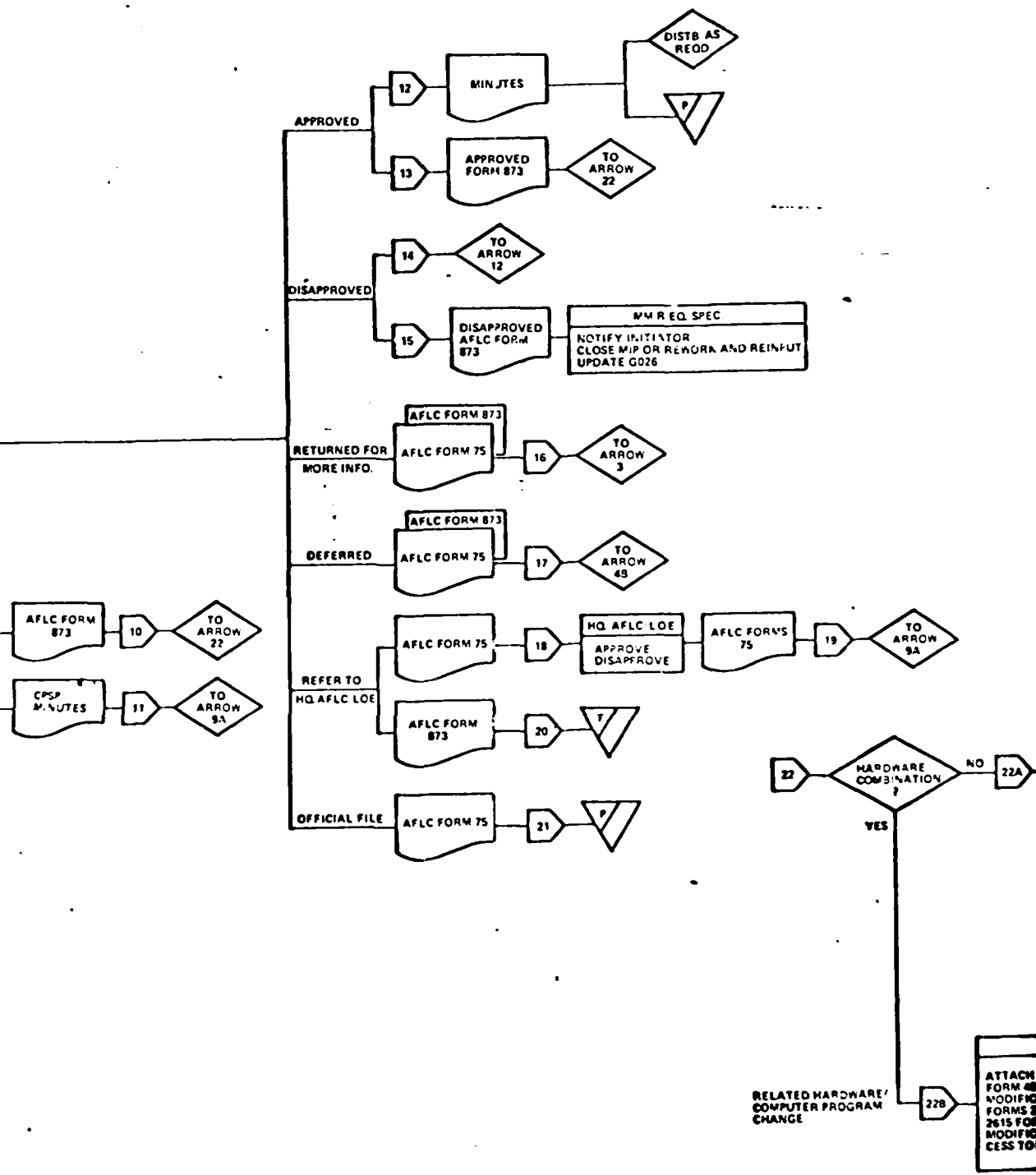

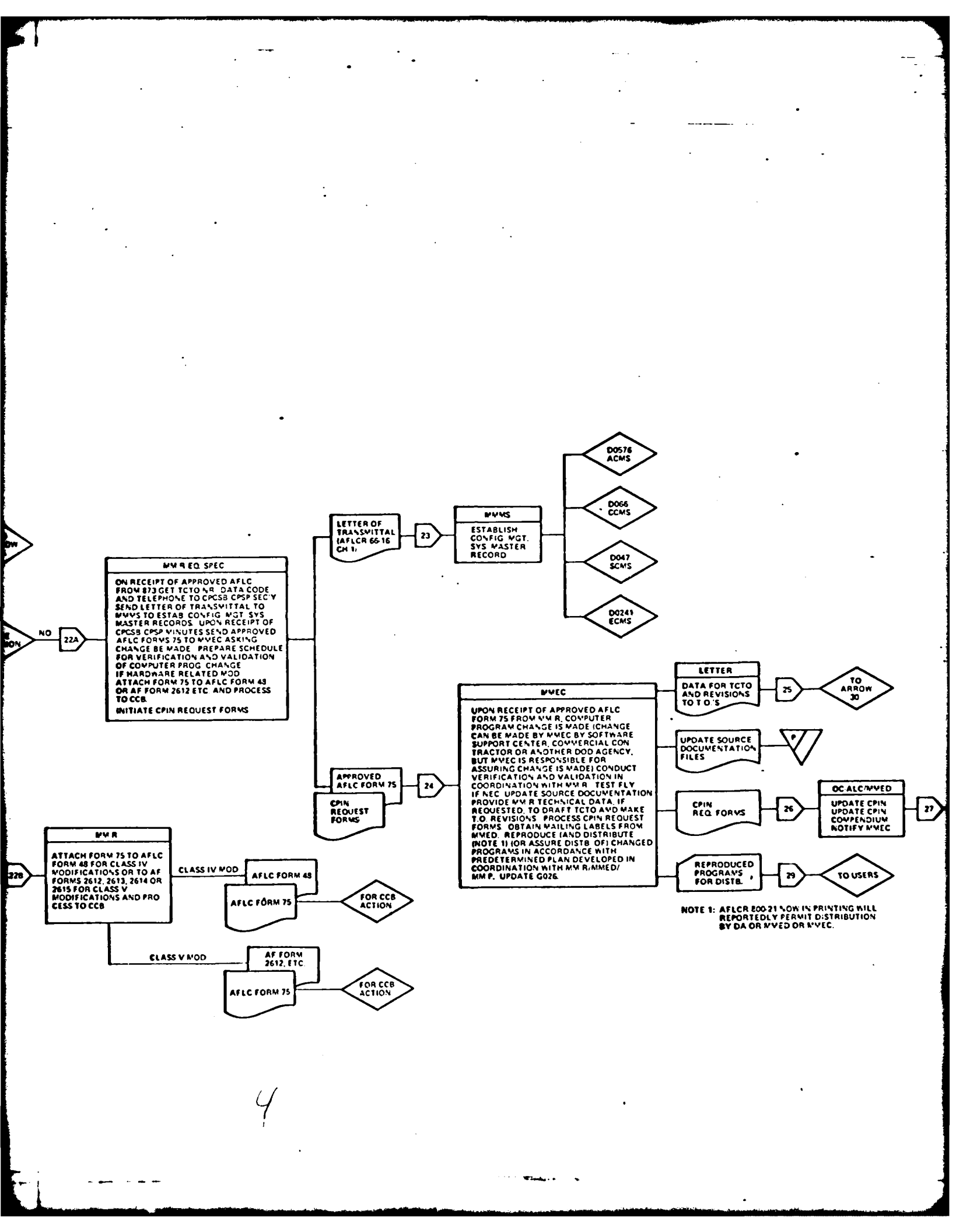

MMR REQ SPEC

ON RECEIPT OF APPROVED AFLC FORM 873 GET TCTO NR DATA CODE AND TELEPHONE TO CPCSB CPSP SEC'Y SEND LETTER OF TRANSMITTAL TO MMMS TO ESTAB CONFIG MGT SYS MASTER RECORDS. UPON RECEIPT OF CPCSB CPSP MINUTES SEND APPROVED AFLC FORMS 75 TO MVEC ASKING CHANGE BE MADE. PREPARE SCHEDULE FOR VERIFICATION AND VALIDATION OF COMPUTER PROG CHANGE IF HARDWARE RELATED MOD ATTACH FORM 75 TO AFLC FORM 48 OR AF FORM 2612 ETC AND PROCESS TO CCB. INITIATE CPIN REQUEST FORMS

MMR

ATTACH FORM 75 TO AFLC FORM 48 FOR CLASS IV MODIFICATIONS OR TO AF FORMS 2612, 2613, 2614 OR 2615 FOR CLASS V MODIFICATIONS AND PROCESS TO CCB

MMEC

UPON RECEIPT OF APPROVED AFLC FORM 75 FROM MMR, COMPUTER PROGRAM CHANGE IS MADE (CHANGE CAN BE MADE BY MMEC BY SOFTWARE SUPPORT CENTER, COMMERCIAL CONTRACTOR OR ANOTHER DOD AGENCY, BUT MMEC IS RESPONSIBLE FOR ASSURING CHANGE IS MADE) CONDUCT VERIFICATION AND VALIDATION IN COORDINATION WITH MMR. TEST FLY IF NEC. UPDATE SOURCE DOCUMENTATION PROVIDE MMR TECHNICAL DATA, IF REQUESTED. DRAFT TCTO AND MAKE T.O. REVISIONS. PROCESS CPIN REQUEST FORMS. OBTAIN MAILING LABELS FROM MVED. REPRODUCE (AND DISTRIBUTE (NOTE 1) FOR ASSURE DISTB OF) CHANGED PROGRAMS IN ACCORDANCE WITH PREDETERMINED PLAN DEVELOPED IN COORDINATION WITH MMR/MMED/MMP. UPDATE G026.

NOTE 1: AFLCR 200-21 NOW IN PRINTING WILL REPORTEDLY PERMIT DISTRIBUTION BY DA OR MVED OR MVEC.

4

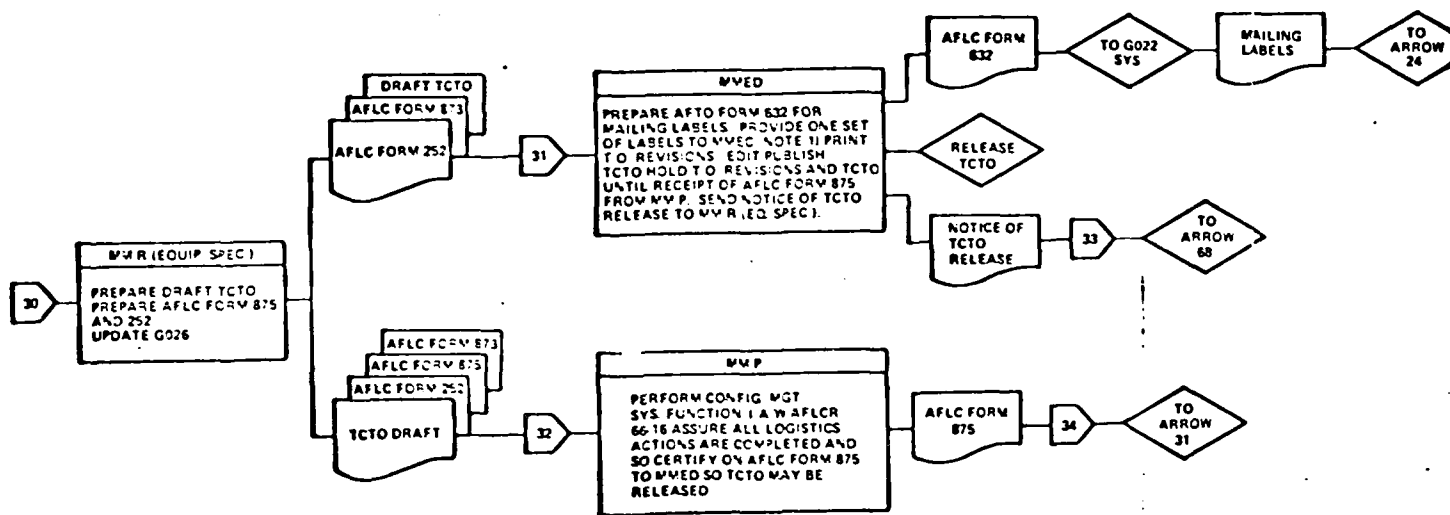

5

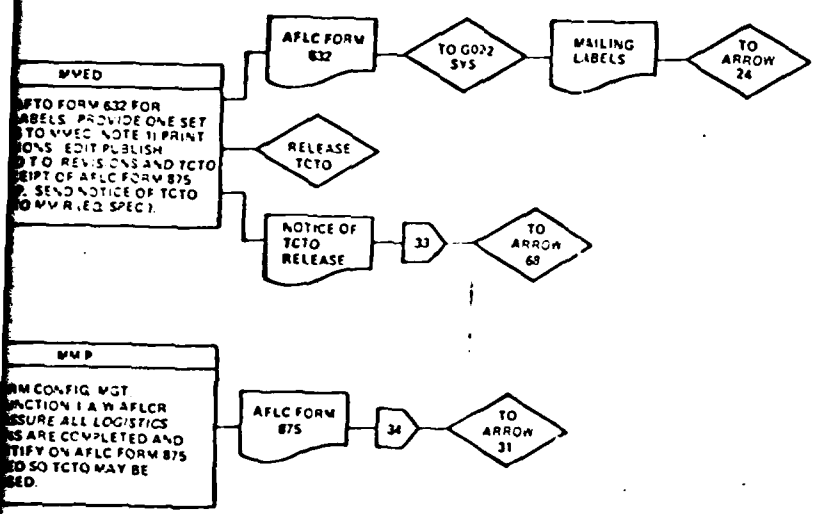

LEGEND	
ORGANIZATIONS	
MVP	PRODUCTION MANAGEMENT BR.
MVR	ENGINEERING AND RELIABILITY BR.
MVEC	COMPUTER RESOURCES BR.
MVED	OPERATIONS AND SUPPORT BR.
MVVS	MATERIAL SUPPORT BR.
OCAL/MVED	OKLAHOMA CITY AIR LOGISTICS CENTER OPERATIONS AND SUPPORT BR.
REGULATIONS	
TO 0035D54	USAF MATERIAL DEFICIENCY REPORTING AND INVESTIGATING SYSTEM
AFLCR 66-15	PRODUCT PERFORMANCE
CHAPTER II	M.P. STATUS REPORTING G026
AFLCR 80321	MANAGEMENT AND SUPPORT PROCEDURES FOR COMPUTER RESOURCES USED IN DEFENSE SYSTEMS
FORMS	
DD FORM 173	JOINT MESSAGE FORM
SF 363	QUALITY DEFICIENCY REPORT
AF 2512	CLASSIFICATION PROPOSAL
AFLC FORM 42	CONFIGURATION CONTROL BOARD ITEM RECORD
AFLC FORM 75	COMPUTER PROGRAM CONFIGURATION SIGN BOARD ITEM RECORD
AFLC FORM 252	TO PUBLICATION REQUEST
AFLC FORM 632	TO DISTRIBUTION AND RECORD REQUEST
AFLC FORM 873	TCTO REVISIONS
AFLC FORM 875	TCTO PROGRAMMING DOCUMENT
CAN REQUEST FORMS	AFLC FORMS 632 NUMBERS BEING CHANGED
DATA SYSTEMS DESIGNATORS	
G022	LOGISTICS MANAGEMENT OF TECHNICAL ORDERS
G0241	ENGINE CONFIGURATION MGT SYSTEM
G026	M.P. STATUS REPORTING SYS
G047	STANDARD CONFIGURATION MGT SYS
G057G	ADVANCED CONFIGURATION MGT SYS
G064	COMMUNITY CONFIGURATION MGT SYS
OTHER	
ACVS	ADVANCED CONFIGURATION MGT SYS
CCVS	COMMUNITY CONFIGURATION MGT SYS
CPCI	COMPUTER PROGRAM CONFIGURATION ITEM
CPSSB	COMPUTER PROGRAM CONFIGURATION SUPPORT
CPS	COMPUTER PROGRAM SCREENING PANEL
CPN	COMPUTER PROGRAM IDENTIFICATION NUMBER
ECVS	ENGINE CONFIGURATION MGT SYS
EDP	ENGINEERING CHANGE PROPOSAL
EQ SPEC	EQUIPMENT SPECIALIST
I.A.W.	IN ACCORDANCE WITH
M.P.	MATERIAL IMPROVEMENT PROJECT
SCVS	STANDARD CONFIGURATION MGT SYS
SM IM	SYSTEM MANAGEMENT ITEM MGT DIVISIONS
TO	TECHNICAL ORDER
TCTO	TIME COMPLIANCE TECHNICAL ORDER
TAD	TEST REQUIREMENTS DOCUMENT

FIGURE 34. MANAGEMENT LEVEL CHART	
TITLE	
PROCESS FOR CORRECTING DEFICIENCIES OR CHANGING COMPUTER PROGRAM CONFIGURATION ITEMS	
CPR.	GOVERNING DIRECTOR
SA ALC MVMVP	AFR 800 14 AFLCR 632

cause MDR's to oscillate between several agencies for coordination purposes. Each oscillation has an inherent "human factor" delay in addition to the actual work time for the document coordination. The cumulative affect of these delays results in MDR's with simplified engineering tasks spanning several months (difficult tasks take longer) for completion. In other words, adherence to T.O. 00-35D-54 and the necessary coordination is a lengthy process and, generally, MDR processing is not timely with respect to user urgency.

ATE MDR's are initiated to correct inadequacies or shortfalls of the ATE testing. Correction of the inadequacy is not always straightforward, thus the associated engineering analysis can take considerable time. Although the responsibility of the Engineering Division, the engineering analysis is often attacked by other agencies. The coordination and control of such activities are not efficient.

3.4 ATE ORGANIZATIONAL CONCEPT

As mentioned in earlier sections, the responsibility for ATE system management is generally assigned to SA-ALC with the UUT assignments being made to IM's at the ALC's. The resultant organizations are aligned to support the ATE assignment responsibilities in accordance with the information flow as assigned by AFLC regulations and as depicted by the diagram in Figure 3-5.

The ultimate purpose of ATE is to verify the operational state of a UUT so in most cases a UUT user identifies a testing need for a UUT. He submits the MDR to the MDR coordinator at the ALC who has UUT responsibility. The coordinator's responsibilities include channeling MDR's to responsible agencies generally identified as UUT item managers. Item managers generally determine that each MDR requires a MIP be established. This determination may require a hardware and/or software engineering analysis and in some cases the item manager can send the MDR directly to the Technical Repair Center (TRC). A third

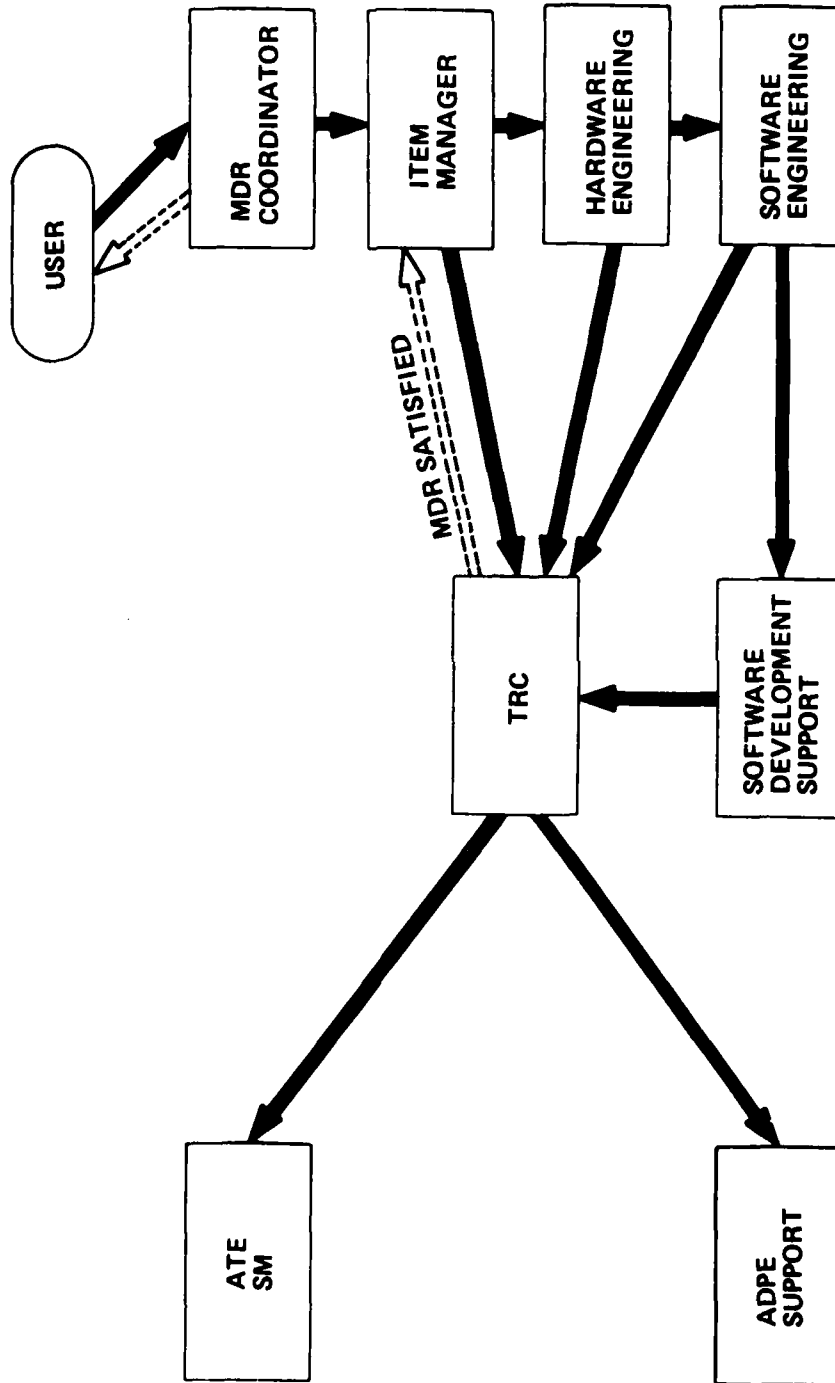

Figure 3-5. ATE Information Flow

possibility is that the MDR could be unnecessary in which case the IM indicates this to the MDR coordinator and all actions are closed. In the event the engineering analysis requires a software development, the request is forwarded to the software developer. Upon completion of the software development the results are included in the ATE testing conducted by the TRC. Certain ATE requires ADPE support and additionally may require coordination with the ATE SM.

It has been previously mentioned that MDR's are sometimes written against the ATE itself. The flow is approximately the same except the ATE deficiency will likely be discovered by the TRC or one of the engineering analysis groups.

Specific organizational alignments to accomplish the aforementioned tasks vary from ALC to ALC. This is partially because the assigned responsibilities and/or areas of emphasis vary for each ALC. As an example, the testing associated with jet engine operation is quite different from testing of electronic black boxes.

Typically the MDR coordinator is located in MMMS with the item managers and the hardware engineering is located within one or more item divisions. Software engineering analysis is located within the computer resources section of MME, software development within the software support center of the maintenance directorate, the TRC functions within the maintenance directorate, the ADPE support within ACD, and the ATE SM is located at San Antonio Air Logistics Center. A conception of the interface complexity of these agencies can be gained by examination, from an organizational viewpoint, of Figure 3-4.

The previous few paragraphs and Figure 3-5 are presented to indicate the basic organizational concept involved with supporting ATE software. In 1975, Software Support Centers (SSC) were first established to play an important role in this concept. Since that time, several amplifying regulations and letters have further defined the SSC and its role. Essentially, SSC's are made up of engineering personnel who use ATE equipment controlled by Directorate of Maintenance (DM) production personnel and who respond to Directorate of Materiel Management ATE software task requests. SSC engineers typically support D/MM

personnel by evaluating ATS deficiencies, identifying required corrections, improving ATE software efficiency and effectiveness, reviewing source data, providing preliminary or final Form 1 drawings of the ITA, providing ATE computer program documentation, arranging access for computer program debug and verification/validation, performing acceptance testing of ATS when required by contract, identifying and projecting requirements for off-line ADPE support, and providing user and programming information to requesting D/MM's in support of ATS acquisitions. Additionally, the SSC's support other maintenance directorate personnel on an as-needed basis for software engineering tasks.

3.4.1 Organization Concept Assessment

The organization associated with ATE varies from ALC to ALC, thus presenting an appearance of non-standardization although the same regulations apply equally to each ALC. Figure 3-6 is included as an example using only the SSC at each ALC; however, similar organizational dissimilarities exist within the Material Management Directorate. This fact coupled with interrelated mission/item assignments cause the organizations to be complex. As the complexity has increased over the years, more management emphasis has been applied by publishing additional guidance regulations. In many cases (see Section 5) these regulations overlap so that some activities, such as engineering analysis, are redundantly assigned. The result is that the current organization is complex, difficult to manage, and somewhat duplicative in responsibilities. In spite of this complexity, the people are making the concept work. They are to be commended for their activities, dedication, and ingenuity.

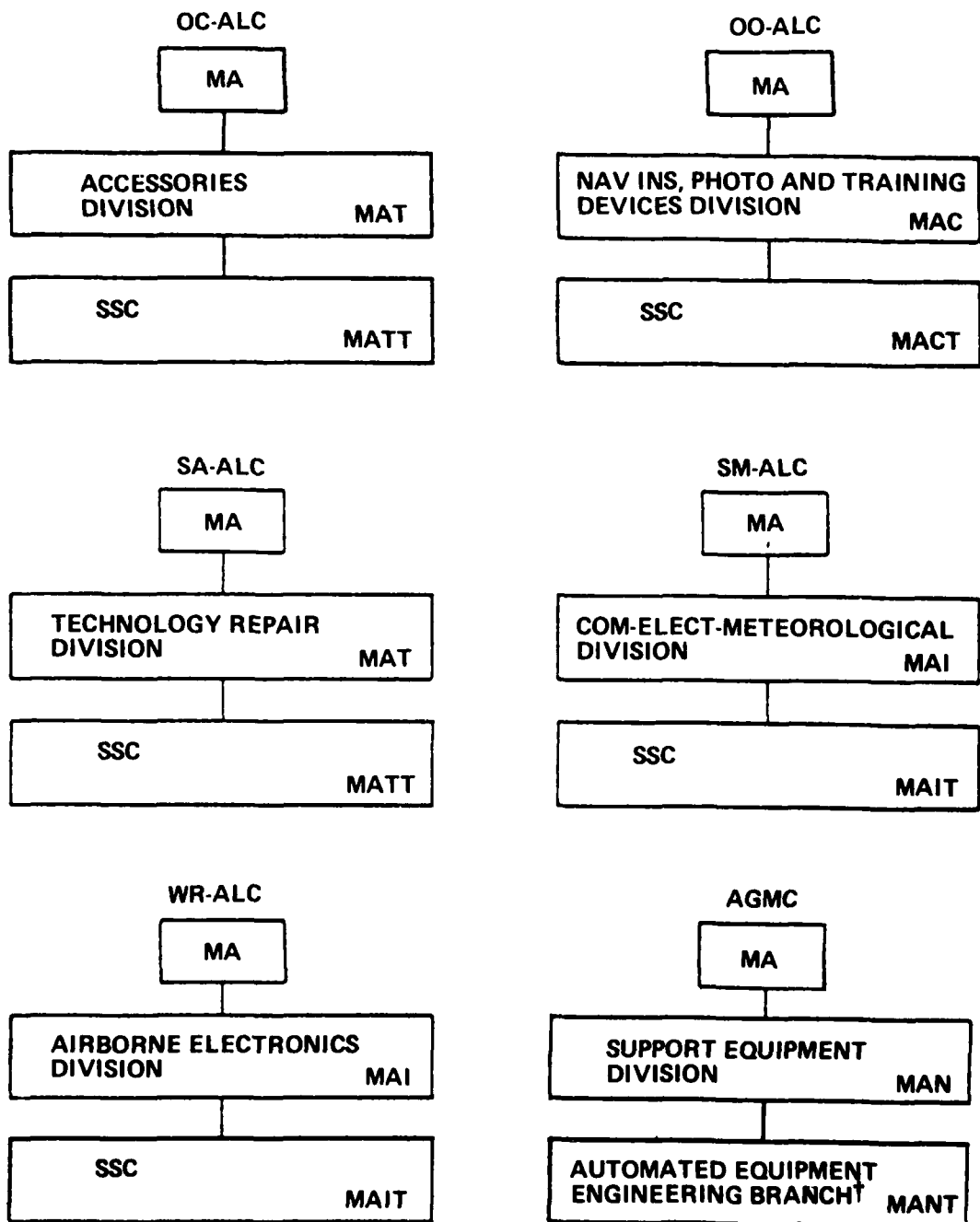

† CONTAINS THE EQUIVALENT OF AN SSC

Figure 3-6. AFLC Software Support Center Chain of Command

4. REPRESENTATIVE SYSTEM AND ATE SUPPORT

The diversity of ATE currently existing within AFLC is enormous. Test systems which automatically respond to a single punched card input are used as well as those that contain sophisticated computers with multiple operator interfaces. In other words, there is a wide variance in the test system complexities. It has already been emphasized that digital/analog testing is entirely different from engine testing. This means that a wide variety of automatic testing applications exists. Additionally, three testing levels of depth, intermediate, organizational are used throughout AFLC. Many of the weapon systems bear little resemblance to each other; i. e., a cruise missile has little in common with a command and control system yet both use embedded computers and both require ATE support.

In view of these considerations, defining an approach to finding a representative sample of automatic testing support problems throughout the command presents a real dilemma. Upon further analysis, it became evident that if testing of a large, complex weapon system were considered from all perspectives then most of the ATE support problems would be addressed. The F-15 was chosen as this system because it is a sophisticated, modern system that makes widespread usage of automatic testing. Accordingly, that system is presented as the representative system in this section. This does not mean that consideration of other weapon systems was excluded.

4.1 F-15 AUTOMATIC TEST EQUIPMENT SUPPORT

The conglomerate total of ATE for the F-15 is divided into the test stations shown in Table 4-1. All stations currently exist except the HP ADTS which is scheduled for delivery commensurate with the programmable signal processor update to the APG-63 radar set. The test station applications are also shown in the table and are self explanatory.

Table 4-1. F-15 Automatic Test Equipment Overview

ATE	Application	User
Avionics Intermediate Shop (AIS)	LRU test at intermediate and depot level (TRC and PDM)	Warner Robins ALC
Computer Station		
Displays Station		
Microwave Station		
Avionics Depot Test Station (ADTS)	Module test-depot level	Warner Robins ALC
Expanded Memory Station		Sacramento ALC (Analog)
Digital Station		Oklahoma City ALC (Analog)
Analog Station		Ogden ALC (Analog)
IF Video/Microwave		Ogden ALC (Digital)
Multifunction Station	Module test-depot level	Sacramento ALC
Comets Digital Station (66FC)	Module test-depot level	Ogden ALC
Comets AGE Tester (6861)	AIS module test-depot level	San Antonio ALC
INS Test Station	INS LRU and module test-depot level	AGMC
INS Accelerometer/Cyro Stations	Depot level test	AGMC
AAI 5500	KB-27 gun camera	Ogden ALC
Tactical Electronic Warfare Sys (TEWS)	LRU test at intermediate and depot levels (TRC and PDM)	Warner Robins ALC
Intermediate Test Station		
TEWS Depot	Module test-depot level	Warner Robins ALC
Test Station		
HP ADTS (DTS 70)	Radar PSP module test depot level	Warner Robins ALC
Engine Component Test Equipment	Engine component test-depot level	San Antonio ALC
Unified Fuel Control		
Gas Generator		
Augmentor Control		
Augmentor Spray Manifold		

Table 4-2 depicts an overview of the software that is used by each F-15 ATE station. Table 4-3 summarizes the test programs that apply to each test station. Table 4-4 summarizes the engine test stands for testing the F100 engine used by the F-15 and F-16 aircraft. Table 4-5 lists the associated software for the test stands for the F100 engine.

The composite of these equipment and software programs makes up the support baseline for the F-15 weapon system. Figure 4-1 indicates the interrelationship of all F-15 ATE systems based upon a breakout by testing level.

Table 4-2. F-15 ATE Software Overview

ATE Station	Control Computer	Control Software Language	Software Test Program Source Language	Compiler/Assembler
AIS	Bendix 6200	Bendix Assembly	F-15 Adapter Place ATLAS	F-15 Adapter Place ATLAS
Computer Displays Microwave				
ADTS	Honeywell H-316	Honeywell Assembly	Honeywell Adapted ATLAS	Honeywell ATLAS
Expanded Memory				
Digital				
Analog				
IF Video/Microwave Multifunction	Varian 620L	Varian Assembly	Modified Machine	None Used
Comets Digital (66FC)	Hewlett Packard 2100A or 2116	HP Assembly and FORTRAN IV	G.D. Adapted ATLAS	Minimum ATLAS
Comets (6861)	HP 2100A	HP Assembly	BETA	Magic BETA
INS Station	Varian 620L	Varian Assembly	Litton Adapted ATLAS	Litton ATLAS
Accelerometer/Gyro Station	HP 2100	HP Assembly	TBD	TBD
TEWS Intermediate	Honeywell H-316	Honeywell Assembly	Honeywell Adapted ATLAS	Honeywell ATLAS
TEWS Depot	TBD	TBD	TBD	TBD
HP ADTS	HP 21 MX	HP 1000 Assembly	HP Adapted ATLAS Basic or Assembly	HP 91074 FORTRAN and HP Adapted
Engine CTE	Data General NOVA 820	NOVA Assembly	NOVA Assembly	NOVA Assembly

Table 4-3. F-15 ATE Test Programs

ATE Station	LRU/ Subassembly	Module	Engine Component
AIS			
Computer	17		
Displays	10		
Microwave	5		
ADTS			
Expanded Memory			
Digital		124	
Analog		154	
IF Video/Microwave		28	
Multifunction		51	
Comets Digital-66FC		31	
Comets-6861		379	
AAI 5500	1	4	
INS Station	1	31	
Accelerometer		3	
Gyro		2	
TEWS Intermediate	27		
TEWS Depot		100	
HP ADTS			
Engine CTE			
Unified Fuel			1
Gas Generator			1
Augmentor Control			1
Augmentor Spray Manifold			5
Total	61	907	8

Table 4-4. F100 Engine Test Stands

Part No.	Nomenclature	O&M T.O	Purpose
PWA 50002	Test Stand, Unified Control	33D4-6-482-1	Simulates engine operating conditions of the unified control and augmentor/distributor sections of unified control to facilitate testing, troubleshooting, and calibration of the UUT.
PWA 50004	Test Stand, Main Section, Unified Control	33D4-6-483-1	Simulates engine operating conditions of the gas generator section of engine unified control to facilitate testing, troubleshooting, and calibration of the UUT.
PWA 50005	Test Stand, Augmentor Section, Unified Control	33D4-6-587-1-1	Simulates engine operating conditions of the augmentor and distributor sections of unified control to facilitate testing, troubleshooting, and calibration of the UUT.
PWA 50012	Test Stand Aug. Spray Manifold	33D4-6-481-1	Simulates engine operating conditions of the augmentor spray manifolds to facilitate testing, troubleshooting, and calibration of the UUT.
PWA 50023	Test Stand, Engine Electronic Control	33D4-6-485-1	Verify performance characteristics of EEC audits power supply and analog interface board assemblies plus provide troubleshooting and diagnostics capability to isolate failures to board assemblies.
PWA 50029	Test Stand, Air Cooled Turbine Component	33D4-6-500-1	Verify performance characteristics of first and second stage turbine rotor blades, and first and second stage turbine stator vanes.
PWA 50030	Test Stand, Engine Electronic Control Digital Subassembly	33D4-6-486-1	Verify performance characteristics of EEC processor, scratch pad, memory, and interface logic subassemblies.

Table 4-5. F100 Engine Depot ATE Computer Programs

Computer Program Identification	P&WA No.	Applicable Test Station	Nomenclature	Tap Checkout Manual (T.O.)	Item Manager	Date
81E-F100-U004-00A	TBD	PWA 50023/30	EEC ROM Test (754768-13)	6J3-4-102-3	SA-ALC/MMP	2-1-76
81E-F100-U003-00A	TBD	PWA 50023/30	EEC ROM Test (754768-23)	6J3-4-102-3	SA-ALC/MMP	8-18-76
81E-F100-U002-00A	TBD	PWA 50023/30	EEC ROM Test (754768-36)	6J3-4-102-3	SA-ALC/MMP	TBD
81E-F100-U001-00A	TBD	PWA 50023/30	Processor Board	6J3-4-102-3	SA-ALC/MMP	5-1-76
6J28-2-8-1CT-1	PWA 50231	PWA 50012	Segment 1	33D4-6-481-8-1	SA-ALC/MMP	11-12-77
6J28-2-8-1CT-2	PWA 50231	PWA 50012	Segment 2	33D4-6-481-8-1	SA-ALC/MMP	11-12-77
6J28-2-8-1CT-3	PWA 50231	PWA 50012	Segment 3	33D4-6-481-8-1	SA-ALC/MMP	11-12-77
6J28-2-8-1CT-4	PWA 50231	PWA 50012	Segment 4	33D4-6-481-8-1	SA-ALC/MMP	11-12-77
6J28-2-8-1CT-5	PWA 50231	PWA 50012	Segment 5	33D4-6-481-8-1	SA-ALC/MMP	11-12-77
6J28-2-8-2CT-1	PWA 50231	PWA 50012	Test Plan	33D4-6-481-8-1	SA-ALC/MMP	6-7-77
33D4-6-1-148-1CT-1	PWA 50229	PWA 50002/4/5	Self Test	33D4-6-1-158-1	SA-ALC/MMI	11-9-77
33D4-6-1-148-1CT-2	PWA 50234	PWA 50012	Self Test	33D4-6-481-8-1	SA-ALC/MMI	3-13-78
33D4-6-481-8-2CT-1	PWA 50231	PWA 50012	Executive	33D4-6-481-8-1	SA-ALC/MMP	3-15-78
33D4-6-482-8-1CT-1	PWA 50225	PWA 50002/4/5	Executive	33D4-6-1-158-1	SA-ALC/MMP	3-15-78
33D4-6-482-8-1CT-2	PWA 50225	PWA 50002	Application Program (AP) Port 1	33D4-6-587-1-2	SA-ALC/MMP	6-7-77
33D4-6-482-8-1CT-3	PWA 50225	PWA 50002	AP, Port 2	33D4-6-1-158-1	SA-ALC/MMP	6-7-77
33D4-6-482-8-1CT-4	PWA 50225	PWA 50002	AP, Port 3	Not Available	SA-ALC/MMP	6-7-77
33D4-6-482-8-1CT-5	PWA 50225	PWA 50002	AP, Port 4	Not Available	SA-ALC/MMP	6-7-77
33D4-6-483-8-1CT-2	PWA 50225	PWA 50004	AP, Port 3	33D4-6-1-158-1	SA-ALC/MMP	6-7-77
33D4-6-483-8-1CT-3	PWA 50225	PWA 50004	AP, Port 1	Not Available	SA-ALC/MMP	6-7-77
33D4-6-483-8-1CT-4	PWA 50225	PWA 50004	AP, Port 2	Not Available	SA-ALC/MMP	6-7-77
33D4-6-483-8-1CT-5	PWA 50225	PWA 50004	AP, Port 4	Not Available	SA-ALC/MMP	6-7-77
33D4-6-587-8-1CT-1	PWA 50225	PWA 50005	AP, Port 1	33D4-6-587-1-2	SA-ALC/MMP	6-7-77
33D4-6-587-8-1CT-2	PWA 50225	PWA 50005	AP, Port 2	33D4-6-587-1-2	SA-ALC/MMP	6-7-77
33D4-6-587-8-1CT-3	PWA 50225	PWA 50005	AP, Port 3	33D4-6-587-1-2	SA-ALC/MMP	6-7-77
33D4-6-587-8-1CT-4	PWA 50225	PWA 50005	AP, Port 4	33D4-6-587-1-2	SA-ALC/MMP	6-7-77
Testek-10463-8	TBD	PWA 50029	Applications	33D4-6-500-1	SA-ALC/MMP	8-15-74

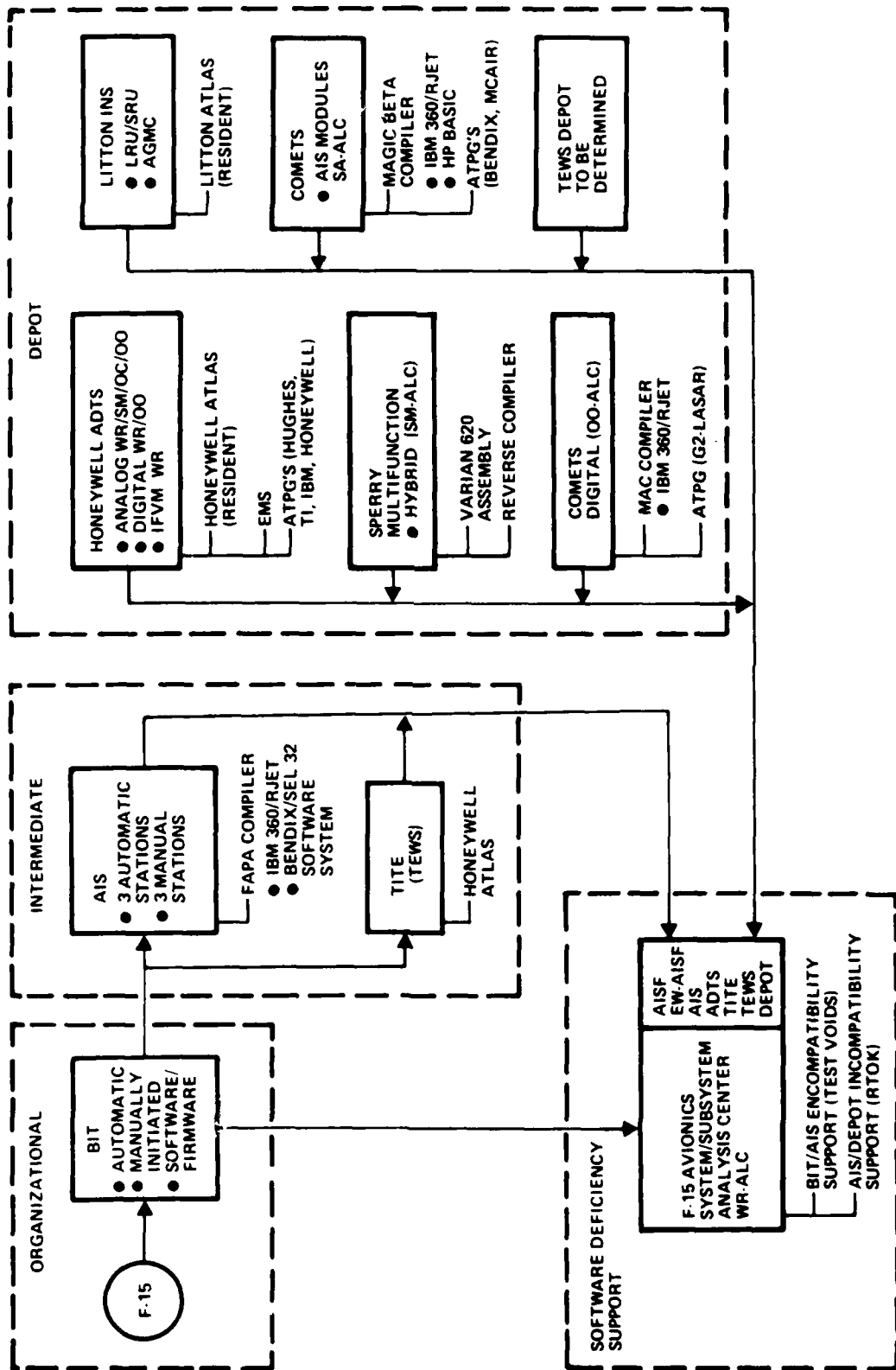

Figure 4-1. F-15 ATE System Interrelationships

5. ASSESSMENTS AND DISCUSSIONS

Automatic testing within AFLC is generally being satisfactorily accomplished; however, certain inefficiencies and conflicting management controls exist. Testing support for complex systems is, like the systems themselves, complex. The promise of increased complexity is apparent for the near future as appreciable effects of any acquisition standardization are not expected for several years. Projects such as MATE and standard data buses, as well as better up front planning, will ultimately enhance testing support within the command.

Overall, the current assessment of ATS within the command reveals that the disciplines and controls are still in a dynamic state with stability not yet achieved. The Air Force, like many of its industrial counterparts, is evolving an improved concept of ATE management which will stabilize within the next few years. Recent history indicates that some weapon systems are readily automatically tested and others are still striving to achieve that goal.

The following paragraphs are offered to acquaint the reader with some of the evolving areas. Some problems and/or issues are pointed out in the discussion and should be considered by AFLC Headquarters for correction or improvement.

5.1 ACQUISITION/DEVELOPMENT DISCUSSION

The bulk of ATE engineering activities occur when the weapon systems are under development. Post-PMRT activities utilize engineers for both hardware and software changes; however, the rates of change are much lower than during the full-fledged development period so engineering resource utilization is lower. Several areas of the following discussion are devoted to acquisition and development because it is this area to which adjustments can be made to provide more influence upon

engineering resources. Implementation of the areas is a responsibility of AFSC, but AFLC inputs are required. Perhaps a better understanding of the total objective of the acquisition and the associated automatic testing will improve both the implementation and the input data. Specifically, the topics to be discussed are the Modular Automatic Test Equipment (MATE) project, test program set development, UUT test program quality, Design For Testability, Software Support Center developments, and equipment modifications. There is some degree of overlap in these various subjects because they influence each other, yet there is a distinctive difference in the various subjects.

5.1.1 Modular Automatic Test Equipment Project

For several years Department of Defense expenditures for weapon system maintenance have been exceedingly high. Greater than 20 percent of the annual DOD budget is spent for this purpose. Automatic testing comprises a large portion of the maintenance figure and proliferation of ATS is widespread. Accordingly, the Air Force has initiated a project called MATE to:

- Develop a management system to systematize and control the acquisition and use of ATE
- Produce a broad based modular hardware and software system design that enables multi-weapon system support at all maintenance levels
- Generate testability criteria to be applied to the avionics and ATE designs

The MATE concept will emphasize centrally coordinated ATE management through the support equipment SPO to provide interchangeable hardware modules, software modules, and human interface modules for various ATE systems. USAF's MATE program plan is depicted in Figure 5-1

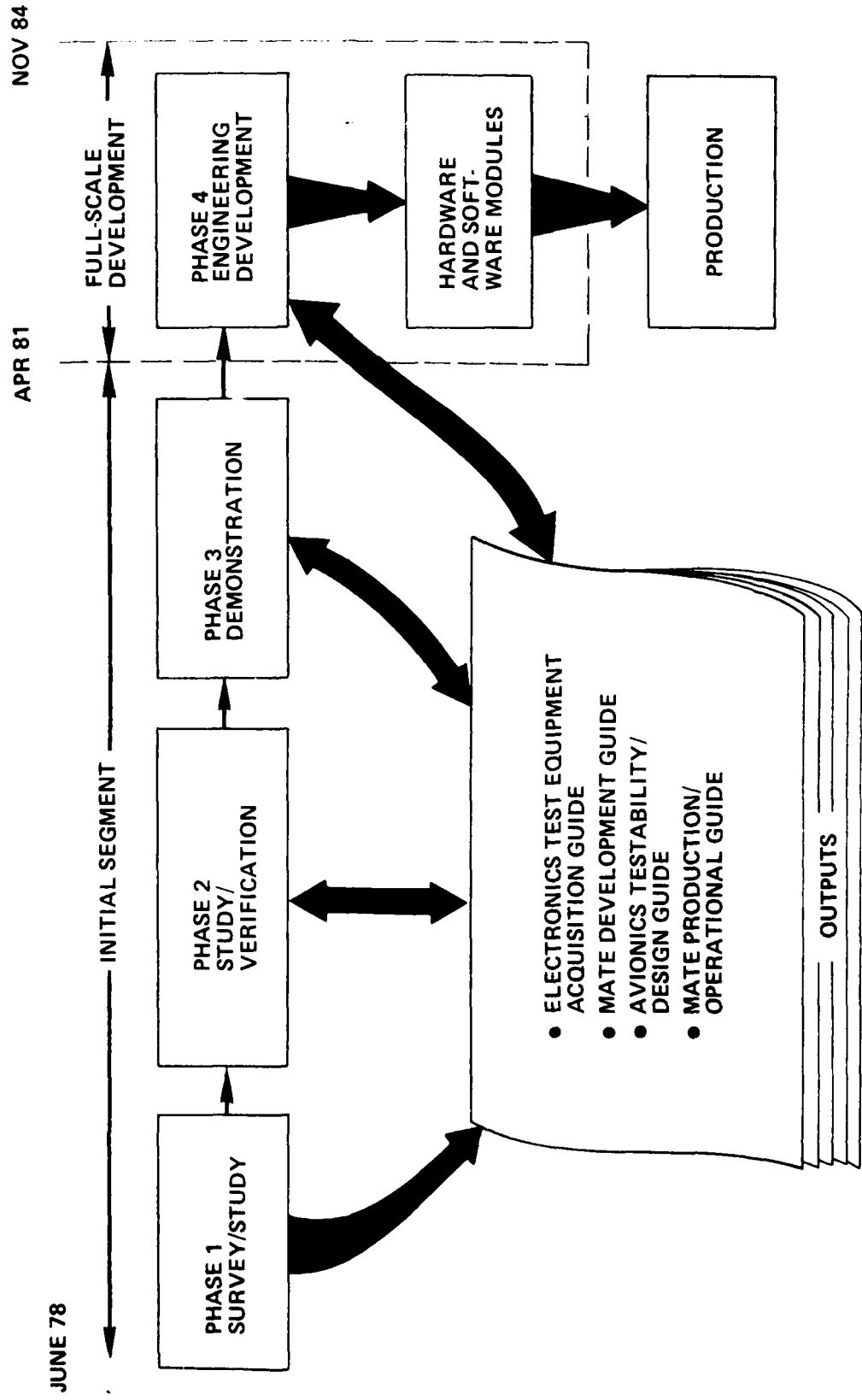

Figure 5-1. USAF MATE Program Plan

Currently, the MATE project is in a competitive environment between Westinghouse and Sperry both preparing the guides shown in the figure. The full-scale development will be awarded after the demonstration phase.

MATE has the potential for lessening the AFLC support requirements for ECS software because of the applicability of modular hardware and software to multiple weapon systems. Additionally, use of standard data buses such as IEEE 488, 1553B, etc. will reduce the equipment/software proliferation.

5.1.2 Test Program Set Development

A Test Program Set (TPS) consists of a complete software package, including a test tape or disc, interface device, and test program instruction. The complexity of the TPS, encompassing the ITA hardware design and the writing of the test program (including a self-test for a complex ITA), is one of the major costs of a weapon system acquisition. The degree with which compatibility is attained between the avionic hardware (UUT) and the ATE impacts the complexity of the ITA and test software. When testability (see paragraph 5.1.4) is designed into the hardware, it can significantly reduce these costs. The effectiveness of ATE support is directly related to the quality of the TPS and the design of avionics.

Figure 5-2 indicates the relative costs for the preparation of an ATE computer program. Percentages shown are approximations based upon data compiled for previous program developments. The larger costs are associated with analysis and program design. Figure 5-3 indicates the functions involved in generating TPS. Considering the activities necessary to complete the generation process, it is no wonder that development of a TPS is expensive.

5.1.3 UUT Test Program Quality

As mentioned in an earlier section of this report, many of the UUT test programs are delivered to AFLC in an unuseable or incomplete state. This is a widespread problem which has several factors that

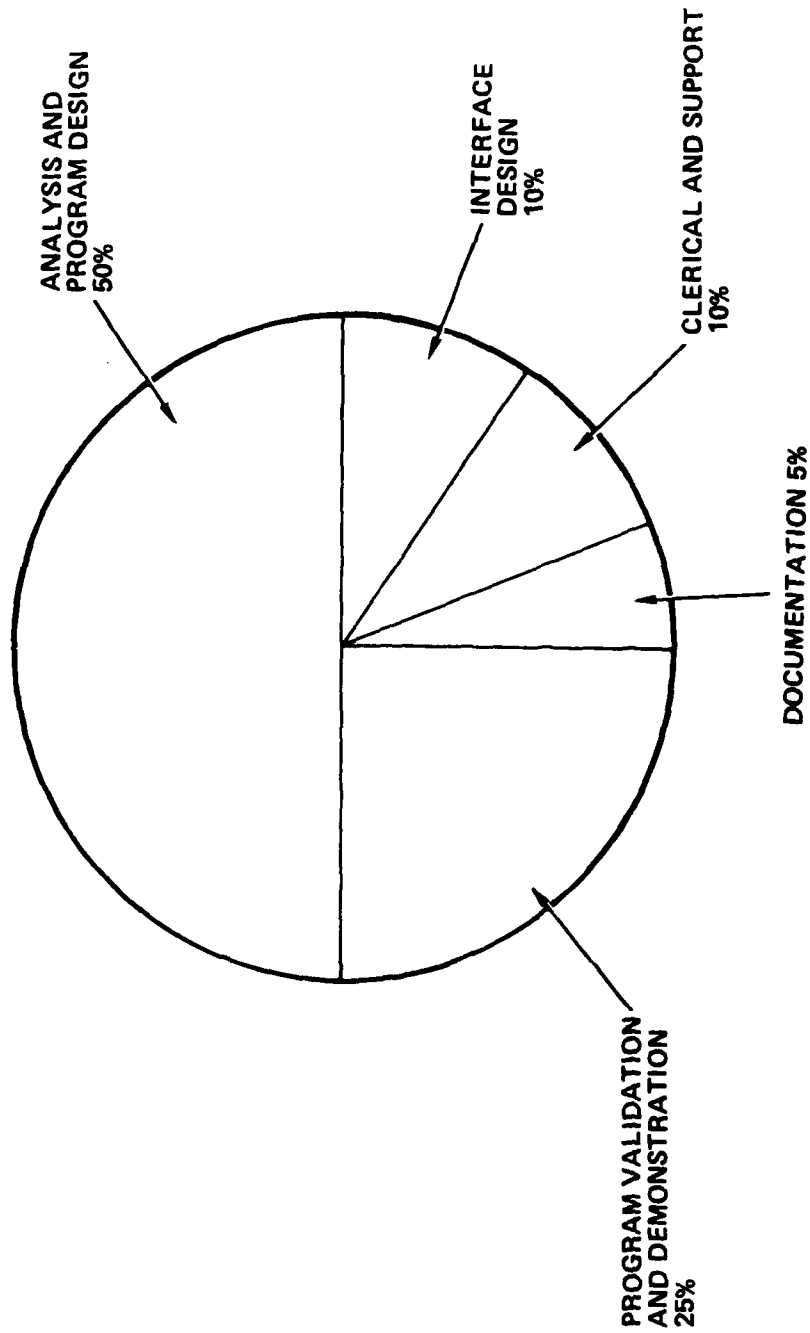

Figure 5-2. Major Tasks in the Preparation of an ATE Program

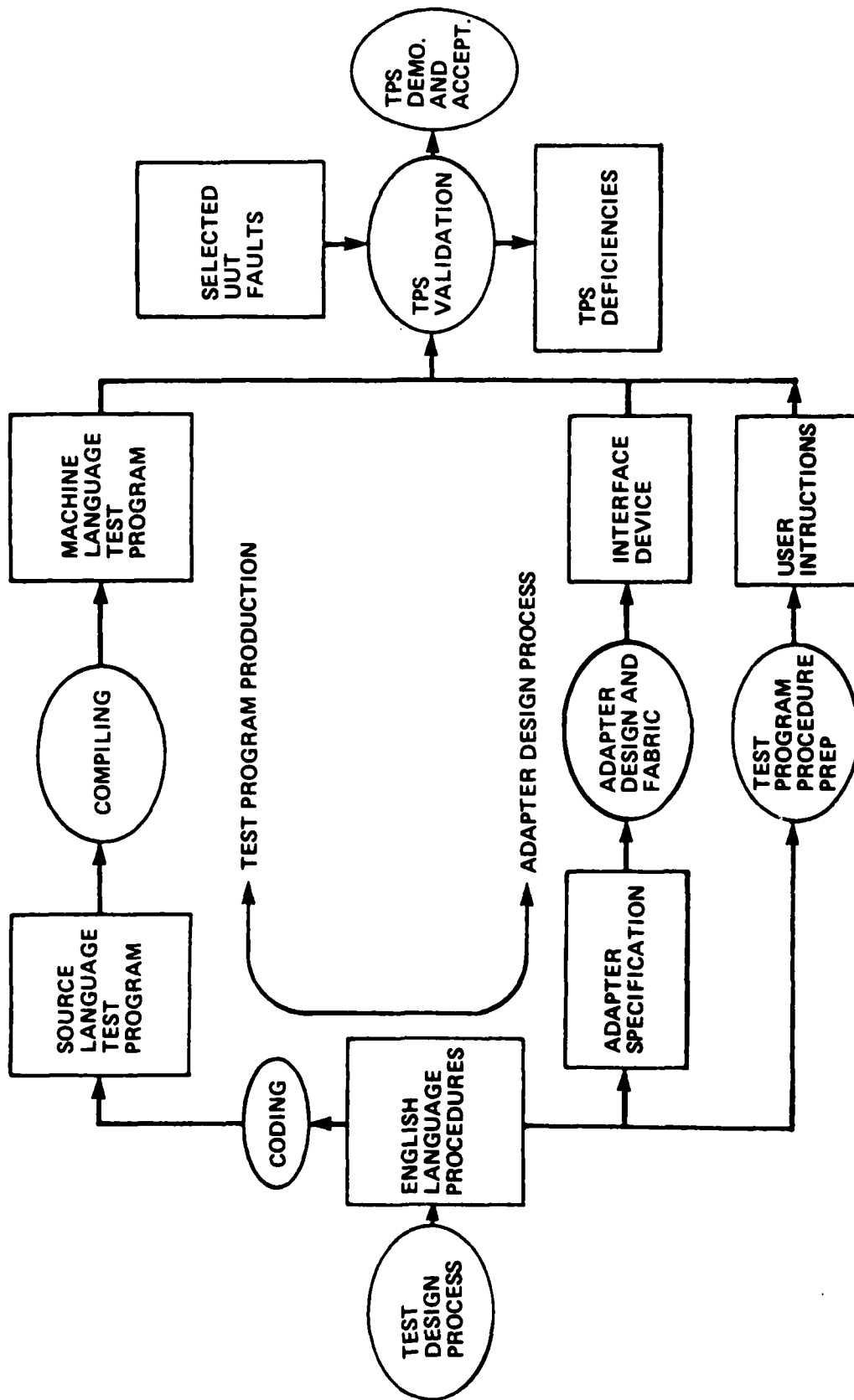

Figure 5-3. Process of TPS Generation

influence the UUT test program quality, thus it is appropriate that the entire process of conceiving and developing test programs be addressed.

The first step in determining what ATE and test software is necessary for UUT's is to conduct a level of repair analysis. This analysis determines and compares the life cycle cost for repair with the life cycle cost for discard at a given maintenance level, justifies the decision to repair or validates use of ATE, and indicates the most powerful variables such as mean time between failures or unit cost.

Step two is a test requirements analysis of a UUT to determine performance requirements and failure modes necessary for generating test philosophy. The results of this UUT analysis document the interface between UUT design and test program design.

Combining steps one and two produces the Test Requirements Document (TRD). A TRD aids the developer in standardizing the data collection process and data package so he can generate a test program or procedure for a UUT and/or determine the type of equipment required. Typically, UUT test program quality is directly proportional to the TRD quality so the key to good test programs is good TRD's.

At this point, an analysis needs to have been conducted with inputs from AFLC, AFSC, and the UUT vendor. Note also that TRD's differ substantially from the Part I or II Specifications that describe the UUT. A mixing of the objectives of specifications with the objectives of TRD's will weaken the TRD. Omission of a good input from either of the three parties will also weaken the TRD. It is evident that "up front" planning and analysis is the real key to effective TRD's and the resultant UUT test program. Figures 5-4 and 5-5 are included to indicate the functions involved in acquiring TRD's and validating the TRD data.

Note the interfacing of TRD's and Test Program Set (TPS) as discussed in the previous section. TPS acquisition is a big cost factor in automatic testing, so poor quality TRD's actually transfer these costs from AFSC to AFLC because AFLC has been completing the UUT test program development. Summarily, the quality of TRD's and UUT test programs need improvement.

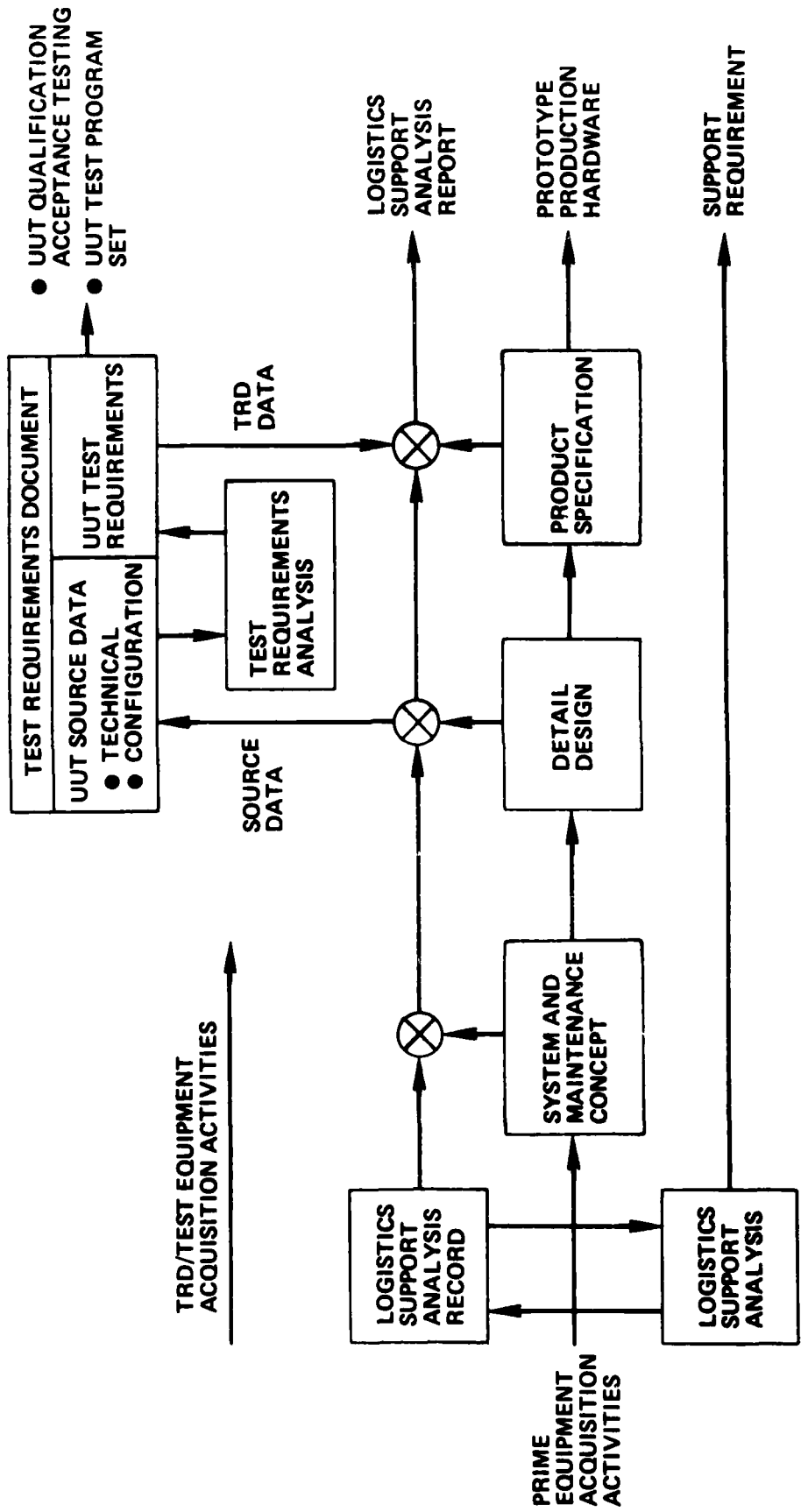

Figure 5-4. TRD Acquisition

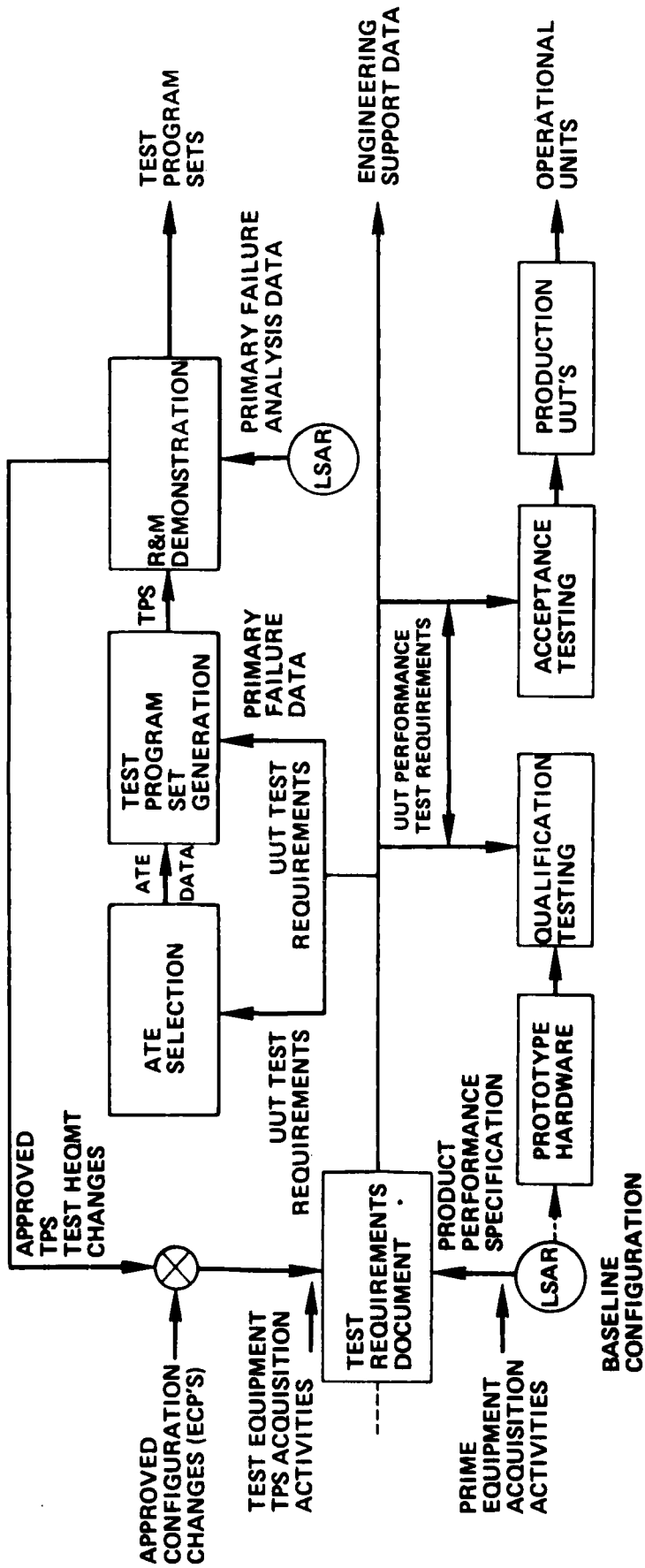

Figure 5-5. TRD Data Validation

5.1.4 Design for Testability

Testability of UUT's is the fundamental reason why automatic test equipment are procured. Early systems (made up of UUT's) were designed to accomplish a function or group of functions but with little or no attention to a method of testing the components of that system. As a consequence, when the system complexity grew to an extensive state some of the system components were virtually untestable. Design for testability then is a UUT design consideration which will enable the UUT to be tested. [MIL-STD 2076 (AS) addresses UUT compatibility with ATE in terms of general requirements].

On-line testability includes Built-in-Test (BIT) and is an inherent portion of the normal UUT operation even though the UUT may only be a portion of a system. Enhanced design for BIT enables the UUT or system to self diagnose or at least to "flag" that it has a deficiency or malfunction.

In design for testability for off-line testing the objectives are to lessen costs through better field performance. Such goals as easier test design, shorter test programs, simpler interface devices, and better diagnostics are desirable. In some cases the goal might be to provide test points for electronic probing measurements.

Design for testability is a total engineering approach combining the activities of the hardware engineer, software engineer, systems integrator, and an integrated logistics system engineer. It considers such activities as fault tolerance, simulation, life cycle costs, standard hardware, test point selection, self-test software, BITE, BIT, failure modes, accessibility, partitioning, and redundancy. (MIL-STD 2084 addresses modularity, test point locations, accessibility, BIT, and testability verification).

Design for testability is recognized as a fundamental requirement which must be levied on all new avionic and automatic test system designs to fulfill MATE goals. The basis of design-for-testability is a MATE maintenance concept that accounts for the appropriate support trade-offs and maintenance levels required by the target weapon system. Establishing a catalog of preferred tests is key to standardizing the approach to testability designs. Historical information and improved design approaches are being developed to permit effective trade-off decisions or use of BIT/BITE and off-line testing and calibration. Both AFSC and AFLC have responsibility to ensure that analysis of technology trends is an on-going process to produce systems that are more easily supportable.

5.1.5 Software Support Center Developments

AFLCR 66-37 indicates the single source of software support is the ALC Software Support Center collocated with (or determined by) the parameters in Table 5-1. For example, if the ATE's test software is to be used at the field level, then the SSC should be collocated with the UUT IM.

AFLCR 23-42 paragraph 22b states the SSC "Designs, develops and provides new, altered, updated or modified test software and updates/ corrects existing avionics items/systems software".

This statement of assignment is somewhat impractical because some test programs such as built-in-test are resident on the operational program and therefore inseparable. Other test programs such as some field test programs must be changed and distributed with the operational software change and it is impractical to have an ATE-SSC located at the repair source make the actual change.

The SSC at each ALC then has definite responsibilities for software development by avionics system assignments. Accordingly, the SSC at each ALC is manned at varied levels and the extent of involvement in software development also varies. Table 5-2 summarizes these facts.

Table 5-1. Extracts From AFLCR 66-37

Software Type	ATE Use			
	Field Level Only	Depot Level Only	Field and Depot	Two or More Depots
Test	UUT-IM	UUT TRC	ATE User TRC	UUT-IM
Self-Test	ATE-IM	ATE User TRC	ATE User TRC	ATE-IM
Control	ATE-IM	ATE User TRC	ATE User TRC	ATE-IM
On-Line Support	ATE-IM	ATE-IM	ATE-IM	ATE-IM

Table 5-2. SSC Software Development Levels

ALC Location	Approximate SSC Manning Level	Approximate Percentage of Assigned Personnel Engaged in Software Development
Oklahoma City	45	20
Ogden	68	5 to 10
Sacramento	155	70
San Antonio	100	15 to 20
Warner Robins	140	45

The percentages in Table 5-2 indicate the extent of involvement by each SSC in developing new software for agencies outside of the local TRC. Any software modification for MDR's on UUT test programs, control software, or support software is not included.

Advantages of accomplishing the "outside" development are:

- In-house expertise is enhanced by exposure of the personnel to actual development of the test software
- Test software gets quality generated (more quality and completion problems exist if the UUT vendor develops the test software)
- Organic development appears to be cheaper

Disadvantages of accomplishing the "outside" development are:

- Other software support may be impacted
- Application of AFLC resources to an AFSC responsibility
- No AFLC mechanism to allow AFLC management control

Analysis of the advantages and disadvantages will lead to a conclusion based upon the perspective of the analyzer. In other words, if one wants to continue outside development he emphasizes the advantages. Those opposed will emphasize the disadvantages.

There are two primary reasons for the SSC's using "outside" development:

- AFSC's history of delivering quality test software is poor, so a "workaround" was implemented
- All TRC agencies/organizations are manned based upon their productivity with "outside" developments sometimes undertaken to keep the people busy, thus precluding any personnel reassignment losses.

5.1.6 Equipment Modifications

Class IV and V modifications represent a large portion of expenditures to maintain weapon systems at a peak operating capability. AFLC's expenditure for this purpose is large and the impact upon AFLC budget and resources is significant. In most cases a change to a weapon system which is significant enough to qualify as a class IV or V modification will necessitate a corresponding change in the ATE. Sometimes the ATE change can be accomplished by altering existing ATE software, but in most cases there is need to change the ATE hardware or perhaps to acquire additional ATE hardware. Unless adequate up front planning and consideration for the affects of a weapon system change on automatic testing are incorporated, the modified weapon system is likely to be unsatisfactorily testable. Any of the factors discussed in Sections 5.1.1 through 5.1.5 can be involved. AFLC involvement from a management planning perspective should be as thorough for a modification as for a new system acquisition.

5.2 MANAGEMENT CONSIDERATIONS

Several areas are included as a subset of the title "Management Considerations". They are presented for consideration of alternative approaches that correct or improve existing deficiencies. None are meant to be of a demeaning or criticizing nature but simply to indicate areas where improvement is needed.

5.2.1 Agency Responsibilities

Regulations which address ATE acquisition and support are numerous. Many are complex in their applications and interfaces with other documents. Figure 5-6, which addresses an overview of AFR 300 versus AFR 800 acquisition routes for ATE, is included as an example. Although acquisition of ATE is normally an AFSC responsibility it is AFLC who is left with the responsibility to support the results of the acquisition. Thus if the acquisition results (weapon systems) are poor, the support tasks are more difficult.

Assignment of responsibility for support is equally as complex as the acquisition. Regulations which apply are numerous but generally ATE is covered in this manner:

- DOD Directive 5000.29 contains the basic policy under which software is managed. This document stresses system management rather than pure software management and it establishes ground rules for life cycle support. It requires that computer programs be managed as deliverable configured items.
- AFR 800-14 implements the broad concepts of DODD 5000.29 through three major documents: Computer Program Development Plan, Computer Resources Integrated Support Plan, and Operational/Support Configuration Management Procedures. It requires that weapon system computer programs be managed under the Computer Program Configuration Item system and establishes the Computer Program Numbering (CPIN) system. AFR 800-14 further established the charter for organic support to weapon system computer resources to include ATE. Volume II of AFR 800-14 provides more explicit guidance or detailed instructions. Among these instructions are such items as: computer programs are to be managed in accordance with established configuration management practices, computer programs are to be managed as part of the system to which they apply, a computer program change is a modification to the system, the regulation prohibits the split responsibility assignment for hardware and its associated computer programs, and the computer program change process is an engineering discipline and requires system integration.

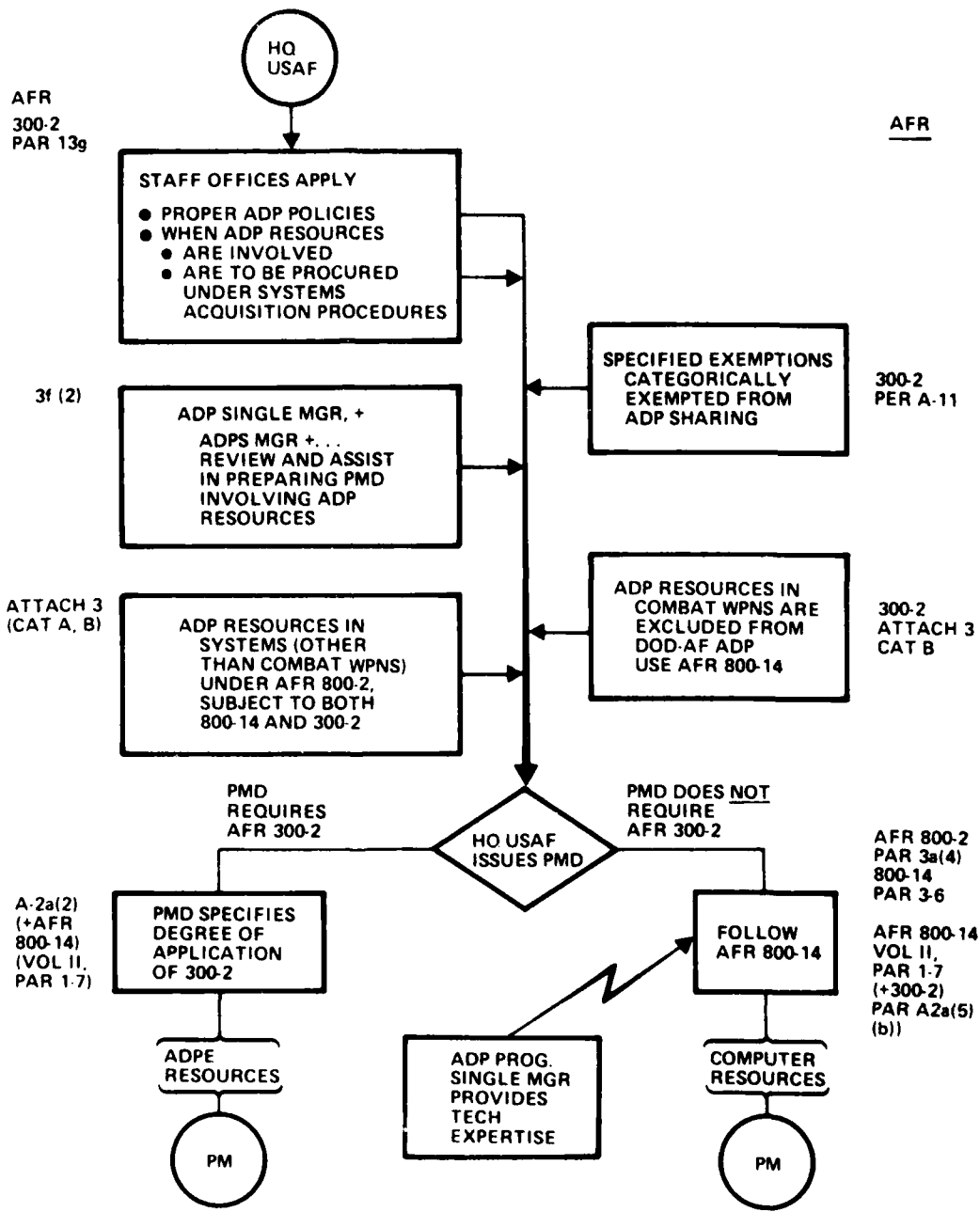

Figure 5-6. ATE Related ADPE Acquisition Procedures

- AFLC Supplement to 800-14 was written primarily to interpret for ALC's the concepts addressed by the basic regulation.
- AFLCR 800-21 was written to provide management oriented guidance that further amplified AFR 800-14 guidance.
- AFLCR 523-1 established the policy governing mission assignments to all AFLC activities. It established management responsibility for ATE hardware, control software, and support software.
- AFLCR 23-42 assigns these ATE responsibilities to San Antonio ALC. It also outlines the SSC responsibilities for support of ATE and ATS.
- AFLCR 23-43 outlines the materiel management responsibilities for ATE engineering support and analysis.
- AFLCR 66-27 assigns tasks for automatic data processing in providing ATE software support.
- AFLCR 66-37 outlines policies for ATS management and responsibilities of Headquarters AFLC, SM, IM, AGMC, ATE users, et al. for implementing.
- Several AFLC Headquarters letters have been sent over the years to provide guidance to the SSC and engineering activities.
- AFLCR 400-1 outlines guidance to the Deputy Program Manager for Logistics (DPML) who resides at the acquisition agency.

Conflicts in assignment responsibility exist because of redundant assignment rather than omission of the assignment. For example AFLCR 23-42 assigns ATE engineering development to the SSC yet, AFLCR 23-43 assigns engineering analysis to the Engineering Division. As pertains to changing ATE programs the terms of development and analysis are virtually synonymous. Similar redundancies exist in other areas.

AFLCR 523-1 policy required that items be managed by FSCM's and repaired by TRC's. Exceptions to this policy have been approved and, in the opinion of some ALC personnel, the basic policy guidance has been seriously eroded. The regulation does not adequately address such items as UUT test software, FSG-70 manager role, and built-in-test.

AD-A115 456

TRW DEFENSE AND SPACE SYSTEMS GROUP REDONDO BEACH CA F/G 14/2
A STUDY OF EMBEDDED COMPUTER SYSTEMS SUPPORT. VOLUME IV. REQUIR--ETC(U)
SEP 80 F33600-79-C-0540

UNCLASSIFIED TRW-34330-6003-UT-00-VOL-

NL

2 of 2

of 10



END
DATE
FILMED
7 82
DTIC

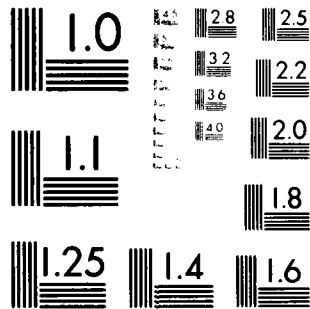

MICROCOPY RESOLUTION TEST CHART
NATIONAL BUREAU OF STANDARDS-1963-A

All regulations are not followed; for example, in its truest context AFR 800-14 precludes separation of hardware and software engineers yet at every ALC the ATE hardware engineers are assigned to the item divisions and software engineers are assigned to the engineering divisions. The question is which regulation or set of regulations overrides or supercedes the other regulations.

Most ALC personnel feel that DPML's are not truly responsive to ALC inputs for ATE acquisition and support. These feelings are based upon the remoteness of access to the DPML's and the fact that DPML's evaluation reports are based upon inputs from acquisition personnel who possess their own parochial interests that do not enhance AFLC objectives.

Virtually all ATE systems contain embedded general purpose computers which are classed as FSG-70 equipment. Yet, the FSG-70 manager's role is not mentioned in any of the AFLC ATE related policy directives. This omission results in vague, incomplete guidance for the management of the computers and their associated control and support software.

For every weapon system that enters the Air Force inventory there is an identified control/focal point at each level of Air Force management; for example, SPO Director, program element monitor, etc. Subsystems such as avionics or landing gear do not have a separately identified focal point yet the subsystems are an integral part of the weapon system and thus reflect some portion of the weapon system capability. Since ATE is not an operational component of the weapon system capability, but is only a support tool, the impetus to acquire the ATE is less than for the weapon system components. Additional impetus could be provided by establishment of an ATE focal point at Air Force Headquarters level similar to that established for embedded computer systems or the electronic warfare panel. Some method of centralizing policy and procedural guidance for ATE appears to be needed at the Air Force level.

5.2.2 Configuration Management

Originally the CPIN system was conceived as an alternate method of identifying computer programs to that established by the technical order process. The main objective was to develop a system that produced more configuration control and that uniquely identified each computer program in a manner that traced the program to a specific weapon system or subsystem. AFR 800-14 requires that each computer program be controlled at computer program configuration item level. This guidance, coupled with CPIN guidance, can allow just a few CPIN numbers to cover the multiplicity of software programs in a weapon system. The usefulness of this system has not been demonstrated at the ALC worker levels.

On a command-wide basis configuration control of ATE is not on a quality basis. Weak documentation adds to this problem, but mostly it is attributable to inadequate policies and procedures. Several automated configuration management systems have been attempted yet none is considered adequate. On a lower level the process used at WR-ALC seems to adequately address this issue for ATE; however, the other ALC's appear to be in a weaker environment. This assessment is made because ATE equipment and associated programs to include source descriptions are not available or up to date at the ALC's. Configuration control implies that not only are complete ATE system descriptions known and available, but that changes thereto can officially be made only after adequate management approval. Several areas of discrepancy were confirmed to indicate a relative lack of configuration control.

Software changes to ATE were addressed in Section 3 and are processed via MDR's in accordance with T.O. 00-35D-54. Without exception the ALC personnel consider this process too lengthy and suggest that it be streamlined.

5.2.3 Logistics Management Applied to Engineering Problems

Earlier sections of this report presented evidence that ATE support has become an engineering problem because of weapon system and tester complexities. Satisfactory testing hinges upon a technical understanding of both the UUT and the tester. Item and/or system managers are rightfully responsible for providing management of UUT's. However, in some cases because the impacts of software changes to either the UUT or ATE are being misjudged by the responsible managers and because requested engineering analysis is inadequate, erroneous decisions occur. The decisions are so technical and complex that meaningful data is beyond the current experience level of some item/system managers. As weapon systems increase in complexity the frequency of complex technical decision making will increase. This means that either the managers should be technically trained or the engineering decisions should be delegated to the engineers.

Ironically, a similar dilemma extends to higher management levels. In many cases the mechanisms do not exist to allow meaningful data to get to the ATE decision maker in a clearly understandable state. Thus the decision maker faces a threat of acting without complete knowledge of the impact of his action.

Coupled with the management concern is the scarcity of travel funds available to engineers during the development phases of weapon systems and their associated ATE. This scarcity can only be compensated for by additional "up front" planning and improved quality from the acquisition agency with additional emphasis applied by AFALD. Both planning and acquisition are known existent problems addressed in Section 5.1 of this report so rectification will not be easy. In many cases the absence of a few hundred dollars in travel money results in expenditures of additional thousands because of attempts at remote control management.

5.3 INDUSTRY VERSUS AIR FORCE COMPARISONS

Many areas of concern to the Air Force are of equal concern to industry. For example "retest O.K." problems are just as prevalent in industry and cause just as many reactions as in the Air Force. Because ATE is in such a dynamic state and many of the same problems exist several joint actions have been initiated. Among these actions are: the Scientific Advisory Board Panel on Automatic Testing currently in session and expected to report in late 1980, the Industry/Joint/Services Automatic Test Project begun in 1977 and completed in December 1979, and several groups to address standardization, modularity, and term definitions.

The results of the Industry/Joint Services Automatic Test Project culminated in over 100 recommendations. Summarization of the system-software development and maintenance problem is quoted from the Executive Summary Report as: "The development of automatic test system software is a complex process, which differs subtly from that of other DOD software. Unfortunately, there is no consistent, top-down understanding of the complex hardware/software relationships involved. As a consequence, cost reduction and control are ineffective, and software maintenance is unnecessarily hampered by the many versions of non-rehostable, proprietary software products that are developed."

Project recommendations are quoted as: "Rigorously define software life cycle, and requirements for configuration control and quality assurance" and "develop guide lines for configuration management and for the maintenance of automatic test system software."

These recommendations are in consonance with this study effort although they more aptly address AFSC responsibilities. AFSC can improve ATE software support by improving management personnel knowledge of ATE, clarifying assignment responsibilities, streamlining change procedures, and applying increased emphasis to acquisition of weapon systems and test systems.

5.4 OTHER ATE INTEREST AREAS

Automatic testing concepts were initially conceived to use a smart machine that could be operated by an inexperienced or relatively untrained individual. As the concept was applied to the support of the F-111 and the F-15 the discovery was made that the ATE did not reveal the functional faults of some UUT's that were known to contain faults. In fact determination of the faults sometimes presented a lengthy, cumbersome task in which the engineering talent was more or less pooled together to analyze the situation. Additional to this, the Avionics Integration Support Facility (AISF) was used to help determine and isolate the fault. Typically an AISF is used to check avionics subsystems in a recreated or simulated natural environment. These elusive faults seemed to lie somewhere between a pure testing scenario and an AISF scenario. Their isolation needed a more analytical, human interactive approach than what ATE offered but less than a full AISF environment. As a result, some "test aids" were developed.

5.4.1 Test Aids

Several test aids are in various stages of development at Sacramento and at least one is envisioned for Warner Robins. These aids and the need for them were locally determined at the individual ALC and are

either being developed or will be developed by that ALC. Development of ideas such as these are a reflection of the attitude of the ALC personnel to get the job done.

The following test aids are in development at SM-ALC.

- Flight Line Computer Loader (FLCL)-F-111D/F/FB. New capability to load and verify General Nav Computer (GNC); Weapons Delivery Computer (WDC); Navigation Computer Unit (NCU); and SRAM OFP at the flight line. Also provide avionics diagnostics at flight line.
- Mission Data Terminal (MDT) - F-111D/F/FB. Replace existing mission tape preparation unit (AGERD 6660) with new equipment capable of providing both punched and magnetic tape containing mission data.
- Mission Data Loader (MDL) - F-111D/F/FB. Replace existing punched tape mission data loader (AGERD 6659) with new equipment to load mission data from magnetic tapes through the wheel well fill into the aircraft computers.
- Digital Computer Complex (DCC) Test Aid (DCC-TA) - F-111D/F/FB. Provide capability to perform dynamic system test at field shop. This will provide a new capability in field shop to identify and fault isolate system tape time dependent and intermittent problems. This is beyond capability of existing field ATE. DCC includes GNC/WDC computers and converter set.
- Inertial Navigation Set (INS) Test Aid (INS-TA) - F-111D/F/FB. Provide capability to perform dynamic system test at field shop. This will provide a new capability in field shop to identify and fault isolate system type time dependent and intermittent problems. This is beyond capability of existing field ATE. INS includes Navigation Computer Unit (NCU); Inertial Reference Unit (IRU); and Battery Unit (BU).
- Inertial Navigation Set (AN/AJQ-20) Test Aid - F/111A. Provide capability to perform dynamic system test at field shop. Provide same capability for F-111A as INS-TA for F/111D/F/FB described above; except this test aid will be manually operated. The AN/AJQ-20 is an analog system, no digital computers. System includes a Stable Platform Unit (SPU) and an analog computer.

- Automated Documentation Tool for Use With F-111D/F/FB OFP Development in AIFS. Provide a means to automatically generate software flow-charts. Considerable savings on flow time and drafting effort.
- Digital Signal Transfer Unit (D-STU) Data Analyzer. Microprocessor controlled data analyzer for testing new D-STU used in F-111D only.
- Navigation Computer Unit (NCU) Memory Modification - F-111D/F/FB. Modification to improve reliability of NCU by replacing existing core memory with Programmable Read Only Memory (PROM) and improved timing. This will preclude memory scrambles in NCU and improve reliability. Flight testing by SAC (several thousand hours) shows an MTBR improvement from approximately 45 hours to over 300 hours.

The following test aid is programmed at Warner Robins. The System Test Analysis Center (STAC) will be designed to resolve all test void and retest O.K. problems within the F-15 maintenance system at all levels of maintenance. It will be established in accordance with the requirements set forth in the F-15 ATE CRISP (Automatic Test Equipment Computer Resources Integrated Support Plan).

5.4.2 Test Approach to F-16 ATE

In determining the ATE needed to provide avionics test support to the F-16 all of the software support requirements were gathered together and grouped according to basic functional tests. This produced a four-station test approach. Each station design was analyzed to determine what common equipment could suffice in each test station. As a result a "common core" was developed which means that interfaces to the core are compatible from test station to test station. Further the components of the core are interchangeable. Subsequent to completion of the prototype test stations the testers were fielded to future users but with vendor maintenance and operation personnel to support the testers. During this subsequent time the users used on-the-job-training and were able to suggest enhancements for the tester man-machine interface.

In summary, the tester design was "front end" planned with standardization and equipment interchangeability in mind where practical. The testers were fielded for trial usage where operational improvements were made. The results look very promising.

This approach appears to already have demonstrated some of the objectives of the MATE program.

APPENDIX A
SA-ALC ATE EQUIPMENT TEST

Nomenclature	A/N Designator	Manufacturer	Usage Level	Testing Level	Application
Automatic Digital Assembly Test Equipment	N/A	Watkins Johnson	Depot/Field	Module	Force/Navy A-C
Computer Test Station	AN/GSM-231	Bendix	Intermediate	LRU	F15 Avionics
Universal Card Tester	N/A	Instrumentation Engineer	Depot	Modules/PCB's	Various Modules
Displays Test Station	AN/GSM-232	Bendix	Intermediate	LRU	F15 Avionics
Automatic Wiring Analyzer	AN/USM-185	DALMO Victor Co.	Field	Circuit	Multi-Weapon Sys.
Analog Digital Tester	N/A	PRD Electronics Inc.	Depot	Module	Modules/Sub-Assy's.
LM-212B Camera Test Set	N/A	CAI, Div or Bourns Inc.	Field/Depot	Module	N/S
Automated Test System for Complex Wiring	N/A	Automation Dynamics	Depot	Circuit	Sys Wiring and PCB's
Automated High Speed Circuit Tester	N/A	Automation Dynamics	Field	Circuit	Sys Wiring and PCB's
Automated High Speed Circuit Tester	N/A	Automation Dynamics	Field	Circuit	Circuits
Automatic Test Systems	N/A	AAI Corp	Depot/Field	LRU/Sub-assemblies	Various LRU
Test Set-Line Replaceable Unit	AN/ASM-479	Boeing	Intermediate	LRU	B-52 EVS
Automated Test System for Complex Wiring	N/A	Automation Dynamics	Depot	Circuit	Sys Wiring and PCB's
Model T170 Test Set	N/A	AVTRON Mfg. Inc.	Field/Depot	Sub Assemblies	Electrical Equip.
Test Set Electro-Optical	AN/ASM-487	Boeing	Depot	LRU/SRU	B-52 EVS
Automatic Circuit Tester	N/A	Automation Dynamics	Depot	Circuits	Any Circuit

Nomenclature	A/N Designator	Manufacturer	Usage Level	Testing Level	Application
Computers/Inertial Test Station	N/A	General Dynamics	Intermediate	LRU	F16 Avionics
RF Test Station	N/A	General Dynamics	Intermediate	LRU	F16 Avionics
Processors/Pneumatic Test Station	N/S	General Dynamics	Intermediate	LRU	F16 Avionics
5500 Series Automatic Test System	AN/GSM-24p	AAI Corp	Depot	LRU and Modules	Variety of Modules
Assembly Tester	N/A	AAI Corp	Depot	LRU and Module (PCB)	-
Datatester	N/A	Datatest Corp	Depot	Component	Circuit Cards
Datatester	N/A	Data Test Corp	Depot	Module	Circuit Boards
Programming Set	AN/GSM-133	Bendix	Intermediate	Module/PCB	Dig./Ana. Modules
Programming Set	AN/GJQ-9	Bendix	Depot	Sys/Subsystem	Aircraft/Missiles
Datatester	N/A	Datatest Corp	Depot and Field	Module	Circuit Boards
Programmer Comparater	ASM-253	General Electric	Field	Card	F-5 LCOSS
Data Acquisition System	N/A	Hewlett Packard	Depot	N/A	Systems
Test Station Electronic Equipment-Equate	AN/USM-410	RCA	Depot	-	LRU
Logic Circuit Analyzer	N/A	General Radio Co.	Depot	Circuits	Circuit Cards
AC/DC Universal Test Set	N/A	AVTRON Mfg. CO.	Field or Depot	Subassemblies	AC and DC Systems
Microwave Test Station	AN/GSM-233	Bendix	Intermediate and Depot	LRU	F15 Avionics
Video Test Station	AN/ASM-233	General Dynamics	Field	Module	F-111
Automatic Circuit Analyzer	N/A	DIT-MCO	Depot	Elect/Electronic Ckts	Circuit
Displays/Indicators Test Station	NS	General Dynamics	Intermediate	LRU	F16 Avionics
Module Test Station (MTS)	N/A	AVCO Systems Division	Depot	Module	Modules

Nomenclature	A/N Designator	Manufacturer	Usage Level	Testing Level	Application
Automated Logic Circuit Test System	N/A	Automation Dynamics	Depot	Module	Cards and Systems
Logic Module Diagnostic Test Station	N/A	Automation Dynamics	Depot	Modules PC Boards	PC Boards/Modules
Automatic Camera Test Equipment	N/A	CAI	Intermediate	Module	Systems/Subsystems/PCB
Digital Logic Module Test Station	N/S	General Dynamics	Depot	Subsystem/Module	Modules
Analog/Digital Test Station	-	General Dynamics	Depot	Module	F-111
Automatic Module Test Station	A/E24T-125	AVCO Systems	Depot	Module	Specific Modules
Flexible Test Station	None	Hughes Aircraft Co.	Depot/Field	Modules	Modules/Subsystem
Data Acquisition System	N/A	Hewlett Packard	Depot	System	Any System
Unit Automatic Test Station	N/A	Hughes Aircraft Co.	Depot	LRU/PCB	AIM-54A Missile
F-111 Age Module Test System	N/A	General Dynamics	Depot	Component	F-111 Modules
Microwave Test Station	N/A	General Dynamics	Depot	Module	F111 Microwave SBU
Inertial Measurement Test Set (IMTS)	AN/ASM-375	Vought Aero Div	Field	Subassembly/LRU	LRU AN/ASN-90
Receiver-Transmitter-Modular Test Station	AN/APM-241	General Dynamics	Field	Module/LRU	F111/APQ-110/128
Computer Test Station	AN/ASM-243	General Dynamics	Field	Module	F-111/AJQ20/ASG23
AFCM Module Test Station	N/A	Honeywell Inc.	Depot	Module	C-5 AFCS
Indicators and Modules Test Station	AN/ASM-379	General Dynamics	Intermediate	LRU/Subsystem	-

Nomenclature	A/N Designator	Manufacturer	Usage Level	Testing Level	Application
Automatic Avionics Test Station	N/A	Martin Marietta Corp.	Depot	System	Multiple
Navigation and Flight Control Test Station	AN/ASM-428	General Dynamics	Field	Module	F-111/ASG25/ASQ119
Converter and Flight Controls Test Station	AN/ASM-427	General Dynamics	Field	Module	F111/Conv. Flt.
Marttron 12000 Automatic Test System	N/A	Martin Marietta Corp.	Depot	Module/LRU	Avionics Units
Naval Air Rework Facility	N/A	Hughes Aircraft Co.	Depot	Module/LRU	AN/AWG-9
Tailored Automatic Functional Support Sys.	N/A	Hughes Aircraft Co.	Depot/Field	LRU/Module	AH-1J/T M65
Programmable Automatic Tester	N/A	Singer Co.	Depot	Modules/PCB	SRAM
Automated Test System	N/A	TEKTRONIC	Depot	Subassembly	Complex Subassy's
Radar Receiver Transmitter Unit Test Sta.	N/A	Hughes	Depot	LRU	This test station
Precision AC/DC Analog Test Station	N/A	General Dynamics	Depot	Module	F111 AC/DC Modules
Automate	N/A	Hughes	Depot/Field	Module/LRU	N/S
Video/Pulse/Analog Module Tester	N/A	General Dynamics	Depot	LRU	Avionics Modules
Navigation and Weapon Components T/S	AN/ASM-425	General Dynamics	Intermediate	F111/Nav/Wpns. LRUS	F111 Nav/Wpns sys.
Horizontal Situation Display Test Station	AN/ASM-452	General Dynamics	Field	Module	F111/HDR. Sit. Disp.
Servo and Indicators Test Station	N/A	General Dynamics	Field	Module	F111/APQ113/ASG23
Servo and Indicators Test Station	AN/ASM-391	General Dynamics	Field	Module	F111/APQ34/113/114

Nomenclature	A/N Designator	Manufacturer	Usage Level	Testing Level	Application
Video Test Station	AN/ASM-432	General Dynamics	Intermediate	Module/LRU	F411/APQ-111
Video Test Station	AN/ASM-433	General Dynamics	Field	Module	F-411
Digital Logic Module Test Station	N/A	General Dynamics	Depot	Module	F-411
Central Air Data Computer Test Station	N/A	General Dynamics	Field	Module	F-411 LRU
Displays Test Station	N/A	General Dynamics	Intermediate	LRU	AVA-9 Indicators
Central Data Processor-Controller/Cenpac	AN/GYK-11	Burroughs	Field	N/A	F-411
Automatic Component-Testing System	N/A	General Radio	Depot	Component	Components
Automatic Leakage-Current Measuring System	N/A	General Radio	Depot	Component	Components
Automatic Leakage-Current Measuring System	N/A	General Radio	Depot	Component	Capacitors
Automatic High Speed Electronics Test Sys.	N/A	Systemation Inc.	Depot	Module	Electronic Assy's
Punched Tape Programmed Inspection System	N/A	Systemation	Depot	Module	Modules
Disc-Programmed Inspection Testing System	N/A	Systemation Inc.	Depot	Module	Modules
Automated Test System	N/A	Texas Instruments	Depot	Module	Various Modules
Inertial Doppler Navigation Equip. T/S	N/A	Northrup Corp.	Field	Replaceable Unit	C-5
Radar System Test Set	N/A	Lockheed Electronics Co.	Field	Line Replaceable Unit	C-5
Automatic Diagnostic System	N/A	Chrysler Corp.	Depot	Modules/PCB	Laser Range Finder

Nomenclature	A/N Designator	Manufacturer	Usage Level	Testing Level	Application
Indicator and Sensors Test Station	AN/ASM-435	General Dynamics	Intermediate	LRU	F111 Avionics
Expandable Computerized Automatic T/Sys	N/A	E Sys, ECI Divisions	Depot	Module/Sub-assembly	Air Force and Navy
Mainframe Automatic Test Equipment	N/A	Emerson Electric Corp	Depot	LRU Module	AN/APQ-153/-157
Printed Circuit Card Tester	AN/USM-401	General Dynamics	Depot	Circuit Card	Digital/Analog CDS
General Purpose Printer Ckt Card Tester	AN/USM-371A	General Dynamics	Depot	Circuit Cards	Digital/Analog CDS
Computer Controlled Test Station	N/A	Bendix	Depot	LRU	Various Modules
Radar Receiver-Transmitter-Modulator T/S	AN/APM-360	General Dynamics	Intermediate	LRU/Module	F111/AN/APQ-114
Automatic Dynamic Digital Tester	N/A	Sperry Microwave Electr.	Intermediate	Module/PC Boards	Digital Modules/PCB
Digital/Analog Test System	N/A	General Radio	Depot	Component	Circuit Cards
Digital Test System	N/A	Hewlett Packard	Depot	PC Boards	PC Board
Computerized Automatic Tester (CAT-M)	N/A	Grumman Aerospace Corp.	Field/Depot	UUT	N/S
Computerized Automatic Tester (CAT-D)	N/A	Grumman Aerospace Corp.	Field/Depot	UUT	N/S
Computerized Automatic Tester (CAT-A)	N/A	Grumman Aerospace Corp.	Field/Depot	UUT	N/S
Logic Circuit Tester	N/A	General Radio	Depot	Circuit	Logic Circuits
Hybrid Automatic Test System (HATS)	AN/USM-403	General Dynamics	Navy-Field	Module/PCB	Navy SA-3 Aircraft
Tactical Jamming System	N/A	Grumman Aerospace Corp.	Intermediate	SRU/Component	EF111A

Nomenclature	A/N Designator	Manufacturer	Usage Level	Testing Level	Application
Logic Test System	N/A	General Radio, Inc.	Depot	Component	Circuit Cards
Digital/Analog Test System	N/A	General Radio, Inc.	Depot	Component	Circuit Cards
Unified Control Augmentor Section T/S	N/A	United Aircraft	Depot	End Assembly	Control Modelfj-A3
Unified Control Test Stand	N/A	United Aircraft	Depot	End Assembly	Control Modelfj-A3
Main Section Unified Control Test Stand	N/A	Unified Aircraft	Depot	Calibration only	Unified Controls
Augmentor Spray Manifold Test Stand	N/A	United Aircraft	Depot	Major Assembly	Spray Manifold
Engine Electronic Control Test Stand	N/A	Unified Aircraft	Depot	Subassy and Board	F100-PW100 Engine Card
Eng. Electr. Control Digital Subassy. T/S	N/A	United Aircraft	Depot	Digital Boards	Card
Engine Electronic Control Burn-in T/S	N/A	United Aircraft	Depot	Assembly	F100-PW100 Engines
Analog Avionic Depot Test Station	A/S	McDonnell Douglas	Depot	Module	F15 Avionics
Digital Card Test Console	N/S	Loral Electronic Systems	Depot	Cards	AN/APR-38 F4

DATE
ILMEI
— 8