



**TAE**  
**G**

TRAINING  
ANALYSIS  
AND  
EVALUATION  
GROUP

(12)

TECHNICAL REPORT 118

**A MANAGEMENT SYSTEM  
FOR RDT&E FUNDED  
TRAINING DEVICE  
ACQUISITIONS IN THE  
NAVAL EDUCATION AND  
TRAINING COMMAND**

APRIL 1982

DTIC FILE COPY AD A 115608

**FOCUS ON THE TRAINED PERSON**

**S** DTIC  
ELECTE  
JUN 15 1982  
**D**  
**A**



APPROVED FOR PUBLIC RELEASE;  
DISTRIBUTION IS UNLIMITED.

TRAINING ANALYSIS AND EVALUATION GROUP  
ORLANDO FLORIDA 32813

Technical Report 118

A MANAGEMENT SYSTEM FOR RDT&E FUNDED  
TRAINING DEVICE ACQUISITIONS IN THE  
NAVAL EDUCATION AND TRAINING COMMAND

Roger V. Nutter  
William R. Terrell

Training Analysis and Evaluation Group

April 1982

GOVERNMENT RIGHTS IN DATA STATEMENT

Reproduction of this publication in whole  
or in part is permitted for any purpose  
of the United States Government.

*Alfred F. Smode*

ALFRED F. SMODE, Ph.D., Director  
Training Analysis and Evaluation Group

*W. L. Maloy*

W. L. MALOY, Ed.D.  
Deputy Chief of Naval Education and  
Training for Educational Development/  
Research, Development, Test and  
Evaluation



Unclassified

SECURITY CLASSIFICATION OF THIS PAGE (When Data Entered)

20. ABSTRACT (continued)

The report:

- presents an overview of the RDT&E process;
- presents the implications of the RDT&E process on Chief of Naval Education and Training (CNET) training system design, acquisition, and support mission responsibilities;
- summarizes the current ongoing initiatives in training RDT&E management;
- describes a proposed RDT&E management system developed during this study for surface and subsurface training device acquisition programs, *ADD*;
- describes some policy issues for CNET consideration. ←

Accession For	
NTIS G3 RI	
DTIC TAB	
Unannounced	
Justification	
By	
Distribution	
Availability	
Dist	

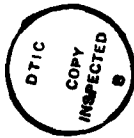

Unclassified

SECURITY CLASSIFICATION OF THIS PAGE (When Data Entered)

# Technical Report 118

## TABLE OF CONTENTS

<u>Section</u>		<u>Page</u>
	PRECIS. . . . .	5
I	INTRODUCTION. . . . .	7
	Background. . . . .	7
	Objectives. . . . .	8
	Approach. . . . .	8
	Organization of this Report . . . . .	9
II	ANALYSIS OF THE CNET ROLE IN THE RDT&E PROCESS. . . . .	11
	The DOD RDT&E Process . . . . .	11
	Policy . . . . .	11
	Implementation. . . . .	12
	Impact of Policy Changes on CNET. . . . .	12
	RDT&E Documentation Requirements. . . . .	13
	Functions of the RDT&E Process . . . . .	13
	Categories of RDT&E . . . . .	14
	6.1 Research . . . . .	14
	6.2 Exploratory Development. . . . .	14
	6.3 Advanced Development . . . . .	14
	6.4 Engineering Development. . . . .	16
	6.5 Management and Support . . . . .	16
	6.6 Operational Systems Development. . . . .	16
	RDT&E System and Equipment Acquisition. . . . .	16
	Acquisition Policy . . . . .	17
	Acquisition Categories . . . . .	19
	Acquisition Process. . . . .	19
	Acquisition Phases . . . . .	21
	Conceptual Phase. . . . .	21
	Validation Phase. . . . .	22
	Full-Scale Development Phase. . . . .	22
	Full-Scale Production Phase . . . . .	22
	Deployment Phase. . . . .	22
	Selected RDT&E Acquisition Topics . . . . .	22
	Documentation Requirements . . . . .	22
	Documentation Changes . . . . .	23
	Documentation Formats . . . . .	24

Technical Report 118

TABLE OF CONTENTS (continued)

<u>Section</u>	<u>Page</u>
RDT&E Organizational Responsibilities and Relationships . . . . .	24
Program Sponsors . . . . .	27
Chief of Naval Education and Training. . . . .	28
OP-098 (Director, Research, Development, Test and Evaluation). . . . .	31
Navy Comptroller . . . . .	31
Chief of Naval Material. . . . .	32
Naval Training Equipment Center. . . . .	33
Test and Evaluation (T&E) Requirements. . . . .	33
Test and Evaluation Policy . . . . .	34
T&E Categories . . . . .	35
T&E Procedures . . . . .	37
Training Equipment Acquisition Management Considerations. . . . .	38
Major Weapon Systems . . . . .	38
Training System Design . . . . .	38
Acquisition and Procurement. . . . .	40
Time Issues. . . . .	40
Training System Design Requirements. . . . .	41
Time Constraints on Front-End Analysis . . . . .	42
Summary of Findings . . . . .	42
III PROPOSAL FOR THE MANAGEMENT OF RDT&E SURFACE-SUBSURFACE FIRST ARTICLE TRAINING DEVICE ACQUISITIONS. . . . .	45
Ongoing RDT&E Related Initiatives . . . . .	45
RDT&E Within the Training Community . . . . .	46
Proposed Training Device Acquisition Management System. . . . .	46
IV STUDY TOPICS FOR CNET CONSIDERATION . . . . .	55
ANNEX A Glossary . . . . .	59
ANNEX B Submarine Trainer Working Group (STWG) Guidelines, Revision A . . . . .	79
ANNEX C Surface Warfare Trainer Group (SWTG) . . . . .	103
ANNEX D Matrix of Training Device Acquisition Management System Documents and Application Area(s) . . . . .	117

Technical Report 118

LIST OF ILLUSTRATIONS

<u>Figure</u>		<u>Page</u>
1	Functional View of the Defense RDT&E Process. . . . .	15
2	Life Cycle of Major Defense Systems and Equipments. . . . .	18
3	Navy Acquisition Categories . . . . .	20
4	ACAT Controlling Documentation. . . . .	24
5	Key Management Organizations in RDT&E Funded Acquisition Programs. . . . .	26
6	Department of the Navy Fund Flow Chart. . . . .	30
7	Test and Evaluation Phases. . . . .	36
8	Life Cycle of Instructional Systems . . . . .	43
9	RDT&E Events and Documentation Flow for First Article Training Devices. . . . .	53

## Technical Report 118

### PRECIS

This report documents the initial step in an ongoing Training Analysis and Evaluation Group (TAEG) effort to develop a management system to implement, within the Naval Education and Training Command (NAVEDTRACOM), the decision to fund first article (prototype) training devices in Research, Development, Test and Evaluation (RDT&E). The development of the required management system must be viewed as an evolutionary process to be refined and modified as necessary to reflect the resolutions of key, yet unresolved, policy, procedural, and organizational issues. Key issues which remained unresolved at the completion of the data gathering phase of the study (November 1981) included the projected documentation and procedural changes in the RDT&E process and the revision of directives describing the intercommand relationships of organizations with respect to the acquisition of training devices. Resolution of these and other issues as they are identified will influence the direction of the evolving management system design.

In this report, a management system is presented that is intended to be generic in nature at this stage of its development. The proposed system defines the relationships among the NAVEDTRACOM, Resource Sponsor, Naval Material Command (NAVMAT), and Chief of Naval Operations (CNO). It is designed to be used within the NAVEDTRACOM for first article, RDT&E funded training device acquisitions. The system design is based on the interpretation of current RDT&E policy directives for major weapon system acquisitions; it is also applicable to less than major RDT&E equipment acquisition programs. The management system concept provides for the integration of training system design requirements and procedures with the documentation and management control requirements and procedures of the RDT&E process. Embedded in the system is the practical application of the fundamental principle of progress through successful demonstration of performance at key acquisition milestones.

Organizations suggested for inclusion in the NAVEDTRACOM management system were identified from mission and function descriptions presented in relevant directives. The role and functions of organizations outside the NAVEDTRACOM are well documented for major RDT&E weapon system acquisitions; however, comparable documentation of their specific roles and functions in first article, RDT&E funded training device acquisitions is not available. The subject of specific organizational roles and functions in first article RDT&E funded training device acquisitions is an issue for future resolution by higher authority. This resolution will be reflected in the final management system design.

Five primary management control documents are envisaged for use in the proposed RDT&E management system. Three of these documents are required to satisfy the documentation requirements of the RDT&E process, the remaining two are required to satisfy specific training system design functions. Document titles have been altered slightly to distinguish them from the documents used in RDT&E weapon system acquisitions.

## Technical Report 118

Future study initiatives will include two major areas of effort, the first being refinement of the generic management system presented in this report, the second being the development of a comprehensive NAVEDTRACOM Management Guide for RDT&E training device acquisitions. These two initiatives are to be addressed simultaneously. Refinement of the management system will include those revisions necessary to reflect all training device acquisition situations, the specific requirements and procedures of the individual resource sponsors, and the resolution of various issues described previously.

The forthcoming RDT&E Management Guide will be designed for practical application at all management levels and will include detailed descriptions of all major elements of RDT&E-funded training device acquisitions.

SECTION I

INTRODUCTION

BACKGROUND

Change No. 5, August 1977, to the Department of Defense (DOD) Budget Guidance Manual specified that first article (prototype) training devices would be funded under Research, Development, Test and Evaluation, Navy (RDT&E,N) instead of procurement (i.e., Other Procurement, Navy (OPN)) budget accounts. In addition to representing more than a change in budget appropriations this decision requires integrating an existing training device acquisition process into a new (RDT&E) acquisition process with new planning, programming, and management procedures. Specifically, first article training device acquisitions must now be subjected to milestone reviews, Test and Evaluation (T&E), and documentation requirements specified within DOD Major System Acquisitions (RDT&E)(DOD directives 5000.1, 5000.2, and 5000.3).

Various initiatives have been taken in the past several years by the Chief of Naval Education and Training (CNET), the Training Analysis and Evaluation Group (TAEG), the Naval Training Equipment Center (NAVTRAEQUIPCEN), and other activities to develop the means and the procedures for adapting training device acquisition programs to the requirements of RDT&E. Each of these initiatives was directed at specific areas of the RDT&E process and not at the process as a whole. Not all areas of the process have been addressed, and there are inconsistencies among some of the initiatives. As a result, the fundamental management principles of the RDT&E process have not been implemented in the Naval Education and Training Command (NAVEDTRACOM). This lack of progress may be attributed to a variety of reasons including the number of complex, interrelated organization, technical, and procedural problems to be considered and the required resolution of certain outstanding management issues. In addition, because of its magnitude and complexity, the problem of adapting training device acquisition programs to the RDT&E process is best suited to solution through a total system approach rather than a discrete area of interest approach.

Certain issues peculiar to the NAVEDTRACOM and training device acquisitions must be considered and successfully resolved before a viable RDT&E management system for first article training devices can be developed. These issues include CNET mission responsibilities; CNET management control functions and procedures; command relationships; Planning, Programming, and Budgeting System (PPBS) requirements; and acquisition time constraints.

In March 1981 CNET tasked the TAEG to examine the current RDT&E process and the CNET role in this process. This examination was to be limited to surface and subsurface programs with emphasis placed on improving the existing training device acquisition process and identifying specific training community acquisition planning requirements and procedures.

## OBJECTIVES

The objectives of this study were to (1) identify the management role of CNET in first article RDT&E funded training device acquisitions, and (2) develop a plan for the management of training device acquisitions that conforms to the principles of the RDT&E process and accommodates stated CNET mission responsibilities.

## APPROACH

The study approach was based on the premise that any RDT&E management system developed for first article training device acquisitions was required to be in compliance with existing principles set forth in current DOD policy directives for RDT&E acquisition programs. Acceptance of this premise placed no undue restrictions on the number of management system design options available for consideration nor did it sacrifice specific training device acquisition requirements necessary to be included in the management system design. As discussed in DOD Directive 5000.1, Major System Acquisitions, flexibility, both in management procedures and acquisition strategy, is an accepted and important principle of the RDT&E acquisition process.

To accomplish the objectives of this study the work effort was performed in two phases.

- Phase I included analysis of official policies (directives, instructions, notices, letters, and memoranda), formal practices, and informal practices related to RDT&E training device acquisitions.
- Phase II synthesized these official policies, formal practices, and informal practices into a viable process that conformed to the stated principles of RDT&E and which would also be acceptable to those charged with the management responsibility for acquiring effective training devices.

Major steps involved in performing this study effort are:

- comprehensive review of all Navy RDT&E process related documents (i.e., DOD, SECNAV, CNO, NAVMAT, CNET, and NAVTRAEQUIPCEN)
- personal interviews with:
  - .. CNO representatives involved in training system acquisition
  - .. CNET personnel responsible for the programming, planning, management, and support of surface and subsurface training devices
  - .. NAVTRAEQUIPCEN Program Planners, Project Directors, Acquisition Directors, and Engineers responsible for developing training devices
  - .. training personnel responsible for the development of related course syllabi

## Technical Report 118

- .. independent agents responsible for the evaluation of training devices
- .. training personnel responsible for the use of training devices.
- identification of new and proposed changes to the RDT&E acquisition process
- determination of the commands currently involved in the acquisition of surface/subsurface training devices and their respective roles
- review of analyses, reports, evaluations, and RDT&E documentation pertaining to training devices in service
- synthesis of all acquired information into concise statements of official RDT&E policy and the translation of these statements into a Training Device Acquisition RDT&E Management System.

### ORGANIZATION OF THIS REPORT

In addition to this introductory section, the report contains three sections and four annexes.

Section II presents an overview of the RDT&E process and the implications of this process on CNET training system design, acquisition, and support mission responsibilities. Section III summarizes the current ongoing initiatives in training RDT&E management and describes the proposed RDT&E management system developed during this study for surface and subsurface training device acquisition programs. Section IV contains a description of policy issues for CNET consideration.

Annex A is a glossary of terms applicable to the RDT&E process and related activities. A copy of the Submarine Trainer Working Group (STWG) Guidelines, Revision A is contained in annex B. Annex C contains a copy of the charter for the Surface Warfare Trainer Group (SWTG). A matrix of training device acquisition references and a listing of the references are contained in annex D.

## SECTION II

### ANALYSIS OF THE CNET ROLE IN THE RDT&E PROCESS

This section presents an overview of the DOD RDT&E process and procedures and their implications for CNET training system design, acquisition, and support mission responsibilities. It is organized under three major topical areas: (1) The DOD RDT&E Process, (2) Training Equipment Acquisition Management Considerations, and (3) Summary of Findings. Requirements and issues unique and critical to training system design and acquisition are examined from the viewpoint of their adaptability to, and compatibility with, the RDT&E process. These issues include requirement identification and validation, time constraints, documentation responsibilities and processing procedures, organizational responsibilities and relationships, Program Objective Memorandum (POM) procedures and responsibilities, training system design procedures, and training equipment effectiveness evaluation.

Subsequent discussion of the RDT&E process and the implications of this process for first article training device acquisitions necessarily includes certain areas of the PPBS; however, the intent of this section is not to present a comprehensive discussion of PPBS. Moore (1977) and various documents cited in annex D of this report address the PPBS in detail.

#### THE DOD RDT&E PROCESS

The RDT&E process is a systematic means for producing the operational capabilities required by the services to meet their total mission responsibilities. These operational capabilities are often erroneously equated only with weapon hardware or materials. In reality, the weapon, training device, training manual, etc. are only the means to provide the operational capability (i.e., piloting a helicopter, fighting a fire, or operating sonar equipment). As stated in the Department of the Navy RDT&E Management Guide (NAVSO P-2457), "The function of RDT&E in the development of operational capabilities is the production of the information required to achieve such capabilities." The process provides management with the means to progressively reduce uncertainty by buying or developing information in logical sequential steps, evaluating this information at critical program milestones, and reaching sound decisions based on demonstrated progress. The concept of the sequential development of information building blocks is just as applicable to training system development as it is to weapon system development. The end products may differ but the development process remains the same. To completely appreciate the applicability of the RDT&E process to training system design it is necessary to first understand basic policy and then to analyze the various steps of the RDT&E process.

**POLICY.** The Office of Manpower and Budget (OMB) initiated a change in basic policy for the Defense System Acquisition Process with the promulgation of OMB Circular A-109 (April 1976). The principles set forth in this circular which are applicable to Navy training include:

- Focus on needs and program objectives expressed in mission terms rather than

## Technical Report 118

equipment terms to encourage innovation and competition in creating, exploring, and developing alternative system design concepts.

- Emphasis on the initial activities of the system acquisition process to allow competitive exploration of alternative system design concepts in response to mission needs with primary reliance on industry.
- Competition between similar or different system design concepts throughout the entire acquisition process.
- Independent test and evaluation throughout the acquisition process with corresponding reduction in emphasis on paper analyses.

**Implementation.** Training device acquisition was directly affected by the new OMB policy with Change No. 5, 12 August 1977, to the DOD Budget Guidance Manual<sup>1</sup> which states:

Training devices.--Training devices that employ new or off-the-shelf computers and system components, but have training system unique software and interface components, will be developed and procured with RDT&E funds. Typically, these training devices have small quantity requirements and the initial or prototype device is used for operational training. The initial or prototype system and all of its support cost through service acceptance will be funded in RDT&E. RDT&E will not fund beyond the initial system unless more than one full system is required to demonstrate the training device performance.

The new OMB policy is further reflected in Navy Comptroller (NAVCOMPT) Manual, Section 075418 which describes the responsibilities of the Training Agent (TA) and the Training Support Agent (TSA) regarding RDT&E first article training device acquisition.

**Impact of Policy Changes on CNET.** The policy decision to transfer prototype training devices from procurement (e.g., OPN) to RDT&E funding represents far more than an adjustment in budgetary processes. The decision has, in fact, had a profound impact upon the role of the CNET in training system design and acquisition. The decision itself is not the issue of this study; however, the various implications (on CNET mission responsibilities) are. The formulation of policy and procedures required to adapt to the RDT&E process requirements set forth in various DOD, SECNAV, and OPNAV directives

<sup>1</sup>Part A Budget Formulation, Section 5 - Research, Development, Test and Evaluation, Chapter 251.

## Technical Report 118

is not a simple task, particularly if CNET responsibilities are to be recognized, factors unique to training device acquisitions are to be satisfied, and the integrity of the training system design process is to be maintained. Adaptation of prototype training device acquisition procedures to RDT&E process requirements (originally scheduled for POM-80 submissions) has been complicated by the promulgation of OPNAVNOTE 5000 (9 June 1981) which indicates that the RDT&E process itself is undergoing significant change. Changes to the RDT&E process are inevitable for the process is designed to be dynamic and flexible to permit adoption of new and more effective techniques for providing needed capabilities to the services. However, the timing of the changes may cause additional uncertainty in the NAVEDTRACOM adjustment to the RDT&E process. Although not complete, significant progress has been made by the NAVEDTRACOM in the difficult adjustment to the RDT&E process; changes have been affected in the areas of management, administration, and documentation procedures. Future progress is dependent to a certain extent upon those yet unspecified future changes to the RDT&E process suggested by OPNAVNOTE 5000. To fully appreciate the recent policy decisions and subsequent required changes, it is necessary to understand the basic philosophy of, and procedures for, the RDT&E process as defined by existing directives.

**RDT&E Documentation Requirements.** Documentation requirements for acquiring training equipment under RDT&E funding differ significantly from those required under the OPN funding process previously used. Not everyone supports the principles underlying RDT&E milestone reviews and document decision points. RDT&E is interpreted as just another hardware procurement system with different documentation requirements. The issue of RDT&E documentation requirements is, at this time, undergoing critical review as discussed in OPNAVNOTE 5000. OPNAVNOTE 5000 indicates that numerous actions are being taken to improve the acquisition process including reductions in unnecessary documentation. Interim guidance on streamlined documentation requirements for the acquisition process is also contained in OPNAVNOTE 5000. One example of streamlining is the replacement of the Navy Decision Coordinating Paper (NDCP) with the Test and Evaluation Master Plan (TEMP) in Acquisition Category (ACAT) III projects. This change will save considerable effort and time in the document preparation and approval process with no apparent loss of integrity to the RDT&E process. Ideally, documentation requirements will be streamlined to the minimum required to ensure retention of the principles of RDT&E and at the same time permit maximum efficiency in the work effort involved in the RDT&E process.

**FUNCTIONS OF THE RDT&E PROCESS.** The RDT&E process has been described as "a multistage information and conversion process characterized by the integration and conversion of information within stages and information flow coupling between stages" (NAVSO P-2457). In actuality, the only justification of DOD RDT&E effort is the attainment of new capabilities required to assure progress in the total operating capabilities of the services. The process consists of two basic functions, (1) the development of the technology base and (2) the development of hardware based operational capabilities. The objective of the process is to reduce hardware development uncertainties and costs (normally high) through development of a sound technology base where uncertainty is high but investment costs are comparatively low.

**Categories of RDT&E.** Conceptually, RDT&E begins with technology based development and culminates in hardware based operational capabilities development. Technology based development is equated with the concept invention and is basically concerned with those initiatives which support the development of new options. Hardware based operational capabilities development is equated with innovation and is concerned with developing the capabilities that the new options invented in technology based development make possible. In general, it is accepted practice in the RDT&E community to equate initiatives categorized as Research (6.1) or Exploratory Development (6.2) to the inventive phase and to equate initiatives categorized as Advanced Development (6.3), Engineering Development (6.4), and Operational Systems Development (6.6) to the innovative phase. The Management and Support (6.5) category is used to provide general support for all RDT&E categories and is, therefore, not equated specifically with either of the two phases (i.e., invention phase and innovation phase). The relation of the concepts of invention and innovation and technology based development and hardware based capabilities development to the RDT&E categories is illustrated in figure 1.

**6.1 Research.** This category is included in the technology base development (refer to figure 1) phase of the RDT&E process and includes scientific study and experimentation directed toward increasing knowledge and understanding in fields (i.e., engineering, physical and behavioral-social sciences) related to long term national security needs. It is designed to provide fundamental knowledge for the solution of identified military problems and to provide part of the base for subsequent exploratory development (6.2) and advanced development (6.3) programs in defense-related technologies. Research effort is typified by study and analysis reports. The CNET is an interested recipient of relevant research effort but does not engage as a major participant in such efforts.

**6.2 Exploratory Development.** This category is included in the technology base development (refer to figure 1) phase and includes all effort directed toward the solution of specific military problems short of major development projects. This type of effort may vary from fairly fundamental applied research to sophisticated breadboard hardware, study, programming, and planning efforts. The dominant characteristic of this effort is that it is pointed toward specific military problem areas with a view toward developing and evaluating the feasibility and practicality of proposed solutions. The CNET is an interested recipient of relevant exploratory development effort but does not engage as a major participant in such efforts.

**6.3 Advanced Development.** This category includes all projects which have moved into the development of hardware and software for experimental or operational test. It is characteristically broken into two stages (refer to figure 1), 6.3A (Advanced Technology Demonstration) and 6.3B (Demonstration and Validation). The 6.3A stage is included as part of the technology base development phase and includes early examination of the feasibility of alternative concepts. The 6.3B stage represents the beginning of the innovative phase of the RDT&E process and includes the demonstration and validation of new technologies. A further descriptive characteristic lies in the design of items being directed toward test or experiment as opposed to items

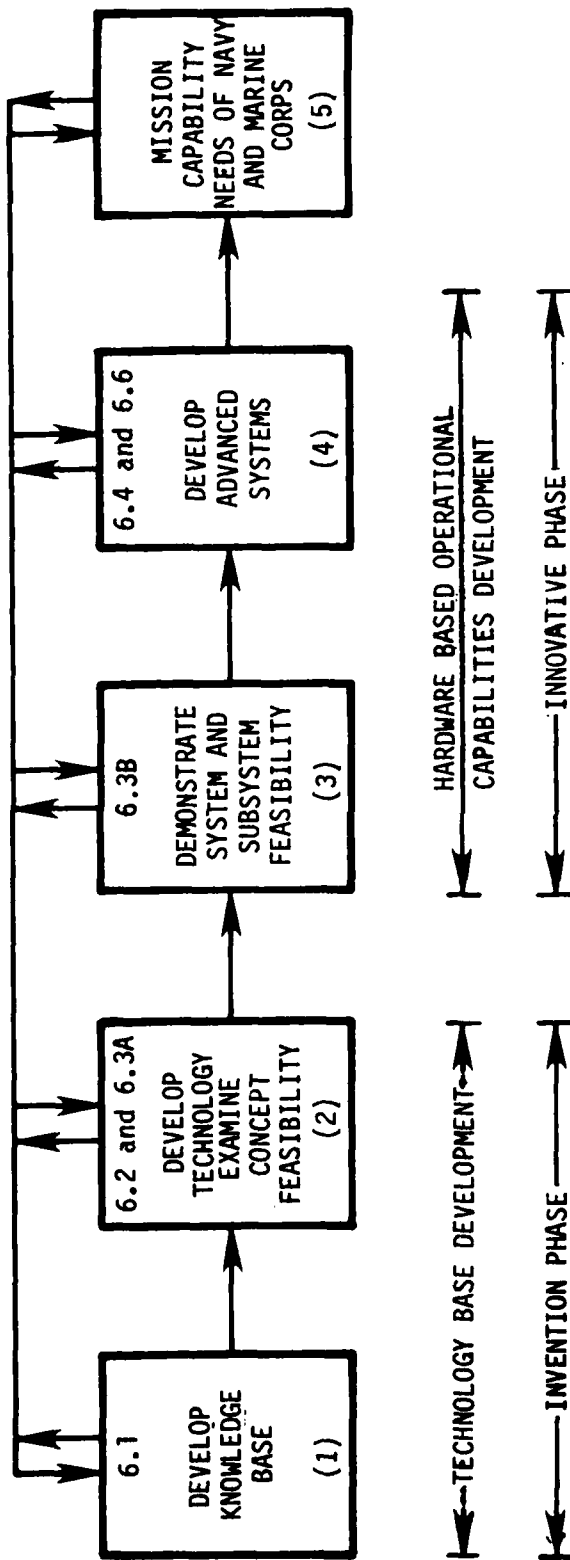

Figure 1. Functional View of the Defense RDT&E Process

designed and engineered for eventual service use. The CNET, though not a major claimant for 6.3 funds, participates with other activities in relevant advanced development programs through cooperative arrangements set forth in CNET Instruction 3920.1B.

**6.4 Engineering Development.** This category is included in the hardware based capabilities development (refer to figure 1) phase of the RDT&E process and includes those development programs being engineered for service use but which have not yet been approved for procurement or operation. This category is characterized by major line item projects and program control by review of individual projects. The CNET is now an active participant in this RDT&E category for it is under 6.4 that first article training devices are procured. Problems associated with CNET management control of this category, necessary for accomplishment of stated CNET mission functions, are addressed under organizational responsibilities and relationships, CNET, pages 28 and 29 of this report.

**6.5 Management and Support.** This category is not included as a distinct portion of the technology base development or hardware based capabilities development phases of the RDT&E process for it provides general across the board support for all RDT&E programs. Examples of this general type of support include test ranges, military construction, maintenance support of laboratories, and studies and analyses in support of the R&D program.

**6.6 Operational Systems Development.** This category is included in the hardware based capability development phase of the RDT&E process and includes research and development effort directed toward development, engineering, and test of systems, support systems, vehicles, and weapons that have been approved for production and service employment. The 6.6 is not an official category as are 6.1 through 6.5 but is a term used for convenience in reference and discussion.

Major training devices are developed in the 6.4 category, Engineering Development. The technology base for training devices already exists. First article training device development basically involves the engineering of known technology into an innovative configuration.

CNET N-5 (Research, Development, Test and Evaluation) has cognizance of 6.1, 6.2, and 6.3, the technology based development categories and CNET N-9, Training System Management, has cognizance over 6.4, the hardware based operational capabilities development category for training devices. CNET N-9 is also responsible for the planning and programming for associated resources in other appropriation categories (i.e., MPN, OM&N and MILCON). It is obviously important to maintain good communications between N-5 and N-9 to ensure the flow of technology base information from technology development to engineering, and technology requirements from engineering to technology base development.

**RDT&E SYSTEM AND EQUIPMENT ACQUISITION.** The relationship between the RDT&E Process and the System and Equipment Acquisition Process can be both frustrating and confusing, particularly to those who have not participated actively in the various activities involved throughout the life cycle of a major DOD program. This confusion frequently stems from the erroneous view that the two processes are independent of one another when in fact they are

mutually supportive with the acquisition process merely serving as the mechanism for transforming the technology data base into a hardware application. In simplistic terms, acquisition begins at the commencement of the 6.3 Advanced Development category of the RDT&E process, however, there is a necessary transition period whereby the acquisition process for major systems or equipments actually begins during technology base development (refer to figure 2). As will be explained later, not all system or equipment acquisition programs commence in the same RDT&E category. Another way of viewing the relationship between the two processes is to refer back to figure 1. As indicated in this figure, four basic functions must be satisfactorily completed, sequentially, prior to achieving a mission capability need. The functions indicated in blocks 3 and 4 cannot be performed without the acquisition of systems or equipment.

**Acquisition Policy.** The successful acquisition and deployment of any major weapon system or equipment involves the active participation of many components of the Department of the Navy. A key to acquisition success is that each component must operate with adequate authority and clearly defined responsibilities. Overall responsibilities and project management authority are in accordance with the DOD PPBS as described in the Department of the Navy Programming Manual. For the Department of the Navy, SECNAV Instruction 5000.1A and the enclosures thereto promulgate the policies for system acquisition established by DOD Directive 5000.1, Major System Acquisition, and 5000.2, Major System Acquisition Process. Whereas these directives and their derivative documents establish policy for the management of major (see annex A) system or equipment acquisitions, they specifically indicate that the management of programs not designated as major (i.e., training devices) are to be guided by their provisions. The provisions of the DOD and SECNAV acquisition policy directives have been designed with a built-in flexibility to provide maximum latitude for the development of sound but not necessarily identical acquisition strategies for the various types of Navy acquisitions.

Policy directives are often maligned for their lack of specificity as they apply to the specific functions in the mission of an activity. However, on the subject of training, DODINST 5000.1 of January 18, 1977 specifically states as policy that:

The number and skill levels of personnel required and human engineering factors shall be included as constraints in system design. The integration of the human element and system shall start with initial concept studies and refined as the system program progresses to form the basis for personnel selection and training, training devices, simulators and planning related to human factors.

SECNAVINST 5000.1A further states that:

The Chief of Naval Operations and the Commandant of the Marine Corps shall:



## Technical Report 118

Ensure manpower and training requirements are established and given consideration in the acquisition process as early as the development of the MENS or equivalent document and support the development and implementation of plans to meet the manpower and training requirements.

Programs may be initiated for one of two purposes, (1) exploring a new technology (Technology Base Development) or (2) in response to an approved need (system acquisition) as delineated in a Mission Element Need Statement (MENS) or equivalent document.<sup>2</sup> It is important to note that not all programs pass through the technology base development phase; i.e., 6.1 and 6.2 RDT&E categories. The required technology may exist whereby program initiation could begin at the 6.3 or 6.4 category depending upon the requirement. Typically, most training device acquisitions will begin in the 6.4 Engineering Development category since an adequate technology base exists and development risk is comparatively low. This practice is consistent in principle with DOD Directive 5000.1 which states as policy: "Mission needs shall be satisfied through the use of existing or commercial hardware and software wherever feasible."

**Acquisition Categories.** Generally, Navy system and equipment acquisition programs are placed in one of four ACATs based upon their RDT&E and production funding levels. The current dollar thresholds for each ACAT are set forth in SECNAVINST 5000.1A and OPNAVINST 5000.42A. The level at which decision authority rests for a system or equipment acquisition program is established by its ACAT. The ACAT also establishes the review group(s) involved in the program and the appropriate program initiation document for the program. For major Navy acquisition programs, and selected programs not designated as major, SECNAV is the decision authority. All other less than major acquisition programs are initiated by the CNO/CMC who provide for the designation of a decision authority and conduct of the programs in accordance with the principles of SECNAVINST 5000.1A. Figure 3 presents summary information for the four ACATs including their decision authority level.

Until recent years the majority of training device acquisitions fell in the ACAT III or ACAT IV category; however, escalating costs are resulting in an increasing number of training device acquisitions reaching the ACAT II funding threshold. The significance of this is that the decision authority moves from the program sponsor to the CNO. If current acquisition directives are adhered to, this could have a significant impact upon planning and approval procedures for some training device acquisitions.

**Acquisition Process.** Basically, the system and equipment acquisition process may be defined as a sequence of specified program activity and decision events directed to the achievement of established program objectives in the acquisition of defense systems and equipment. For management purposes, the life cycle of a major system or equipment is divided into five phases, with a key decision point, referred to as a milestone, preceding each phase. The general relationship of the acquisition phases of a major system or equipment to the RDT&E process,

<sup>2</sup>OPNAVNOTE 5000, 9 June 1981, states the MENS is to be linked to the PPBS process rather than MILESTONE 0 of the acquisition process. The MENS document is currently under review.

Technical Report 118

ACAT	*Thresholds RDT&E/PROD \$(Million)	Decision		
		Recording Document	Review Group(s)	Authority
I	75/300	DCP	ARC or SAIP CEB DNSARC DSARC	SECDEF
II	20/50	MINI- NDCP	ARC or SAIP CEB DNSARC	SECNAV or CNO
III	5/20	TEMP	OPNAV	Program Sponsor
IV	All Other	As determined by NAVMAT	ARB NAVMAT	CNM

DCP: Decision Coordinating Paper  
 NDCP: Navy Decision Coordinating Paper  
 TEMP: Test and Evaluation Master Plan  
 ARC: Acquisition Review Committee  
 SAIP: Ship Acquisition and Improvement Panel  
 CEB: CNO Executive Board  
 DNSARC: Department of Navy System Acquisition Review Council  
 DSARC: Defense System Acquisition Review Council  
 ARB: Acquisition Review Board

\*Note: The monetary thresholds at which programs are designated as major or placed in Acquisition Categories may be expected to change as the acquisition process is affected by inflation and other factors. Current directives should be consulted for correct figures.

Figure 3. Navy Acquisition Categories

## Technical Report 118

planning documents, program reviews, test and evaluation, and other activities is illustrated in figure 2. Whereas figure 2 illustrates the acquisition concept for major systems and equipment, the underlying principles are equally applicable to those acquisitions designated less than major.

As previously mentioned, the process is initiated with the approval of a mission need and extends through successful completion of development, production, and deployment of the system or equipment or termination of the program. It should be noted that an approved need does not in and of itself constitute a commitment of resources. For example, an approved Decision Coordinating Paper (DCP) represents the first commitment of OPNAV RDT&E resources for ACAT I programs. This is the only means by which resources are committed.

The acquisition process is structured to require that each system or equipment program progress through established decision points and phases to completion or termination. As illustrated in figure 2, each milestone decision is directed to the commitment of increased resources to a specified phase of program activity on the basis of demonstrated achievement of program objectives. These key decisions are based upon the advice/recommendation of formal review groups, the makeup of which is determined by the program's ACAT. Factors considered by these groups in arriving at their recommendations include results of test and evaluation (both Development Testing (DT) and Operational Testing (OT)), demonstration of stated program requirements, cost effectiveness, system or equipment supportability and the like. First article training devices are normally acquired at the Engineering Development Phase (6.4) and normally in small production quantities. However, the decision to commit resources to the next program activity phase (production) should still be based on the demonstrated achievement of program objectives. At present, there are no documented formal review groups in the training device acquisition arena. The Submarine Trainer Working Group (STWG) and the Surface Warfare Trainer Group (SWTG) are chartered to serve as screening boards for the CNO Warfare Desks (OP-02 and OP-03) and CNET in developing priorities for device requirement submission and device modification to be included in the OPN and RDT&E POM submissions (refer to annexes B and C). The charters for these two groups do not at present have provisions for a training device review group(s) to perform in the capacity of the acquisition review groups shown previously in figure 3. Key training device acquisition milestone decisions are sometimes made through informal arrangements between the program sponsor and the developing agent.

**Acquisition Phases.** The five phases of the acquisition process are summarized in subsequent paragraphs (refer to figure 2). A more comprehensive description of these phases may be found in Moore (1977) and various DOD and OPNAV directives.

**Conceptual Phase.** This is the first phase in the life cycle of a defense system or equipment and includes the early conception of new systems or equipment to provide focus for Exploratory Development (6.2) planning and program execution required to provide the technology necessary to make the concept feasible. The conceptual phase is highly interactive and consists

of stages which overlap rather than occur sequentially. Generally, these stages include analysis, identification and definition of conceptual systems, and experimentation and test. The output of the conceptual phase includes alternative systems with associated program characteristics; i.e., costs, schedules, and operational parameters. This phase terminates at Milestone 1.

**Validation Phase.** This phase is typically identified with advanced development prototypes and includes intensive analysis and hardware development. The primary objectives of this phase include validation of the major program characteristics through hardware test and evaluation to provide confidence that risks have been resolved or minimized and the ultimate outcome has a high probability of success. Ideally, this phase ends when a "breadboard" model has been successfully demonstrated and the appropriate review group has recommended go-ahead for the next phase to SECNAV.

**Full-Scale Development Phase.** In this phase, normally identified with Engineering Development (6.4), the system or equipment is designed, fabricated and tested including all required support items; i.e., training equipment, maintenance equipment, operation and maintenance handbooks. Test and evaluation is an essential element of the Full Scale Development Phase, both that conducted by the contractor and developing agent (Development) and that conducted by an independent agent of the service (Operational). This phase terminates at Milestone 3, approval to proceed into full-scale production.

**Full-Scale Production Phase.** During this phase the system and equipment including training, equipment spares, etc. is produced for operational use.

**Deployment Phase.** The system or equipment is provided to operational units for use during this phase.

**SELECTED RDT&E ACQUISITION TOPICS.** The fundamental concept of the acquisition process has been presented in previous discussions in this report. More detailed descriptions are included in various acquisition policy directives. There are, however, certain aspects of the acquisition process, not previously addressed, that warrant special attention vis-a-vis the objectives of this study. This is necessary because the topical areas were not of immediate concern as the training community functioned under the previous training device acquisition process; however, with the decision to place training device acquisitions under RDT&E management rules, these topical areas take on added importance, particularly in the development of a new training device acquisition management strategy. These special elements of the DOD system for major system acquisitions include Documentation Requirements, RDT&E Organizational Responsibilities and Relationships, and Test and Evaluation Requirements. Each of these topics is discussed in subsequent paragraphs.

**Documentation Requirements.** Only those documents specifically related to the system and equipment acquisition process are addressed; technology base (6.1 and 6.2) documentation requirements are not included.

Until recently, four fundamental documents were required to initiate less than major RDT&E designated system and equipment acquisition programs. The four fundamental documents and their purpose are:

## Technical Report 118

- Operational Requirement (OR). Serves as the basic requirement document for all Navy programs requiring research and development effort and is required for all Advanced (6.3) and Engineering (6.4) Development Programs. The OR may be submitted by any Navy activity via the chain of command to the cognizant CNO resource sponsor. An approved OR solicits Development Proposals (DP) from the CHNAVMAT or Bureaus as appropriate.
- Development Proposal (DP). Prepared by the CHNAVMAT or Bureaus in response to an OR and provides alternatives and trade offs to achieve a particular range of capabilities.
- Navy Decision Coordinating Paper (NDCP). Used to promulgate CNO decision to initiate conceptual development programs and establish appropriate Advanced and Engineering Development budget line items. They resolve technical alternatives presented in the DP and serve as the basis for preparing Decision Coordinating Papers (DCP).
- Decision Coordinating Paper (DCP). Serves as the principal recording document to record essential system program information for use in support of SECDEF decision making process at Milestones 1, 2, and 3.

The Mission Element Need Statement (MENS), not included in the previously described four documents, was normally used only in major system acquisition(s). Another document, the Test and Evaluation Master Plan (TEMP), was used to identify and integrate objectives, responsibilities, resources, and schedules for all test and evaluation to be accomplished prior to key decision points. It was not used as a program initiation document.

**Documentation Changes.** OPNAVNOTE 5000 (9 June 1981) was issued to provide interim guidance on streamlining documentation requirements for the acquisition process. This directive, though nonspecific in many areas, appears to be aimed at the controlling or recording documentation requirements and not at such documents as the OR and the DP. Apparently, requirements for these documents remain in effect. The new documentation requirements are listed in figure 4 by ACAT. As can be seen in figure 4, the requirements have changed significantly, particularly for ACAT II and ACAT III programs under which many training devices fall. The Mini-NDCP, the format for which is presented in OPNAVNOTE 5000, will apparently be used in lieu of the NDCP which will no longer be used for any program. The TEMP document, common to ACAT I, II and III programs, will apparently be used in some instances as the program initiation document. It is to follow the basic format specified in OPNAVINST 3960.10A but be limited to 10 pages in length for ACAT II and III programs. Mini-NDCPs will be prepared as directed by the program sponsor for those ACAT III programs requiring additional information.

ACAT	Controlling Documentation
I	MENS, DCP, TEMP, IPS
II	MINI-NDCP, TEMP
III	TEMP
IV	As established by NAVMAT

\*Integrated Program Summary

Figure 4. ACAT Controlling Documentation

**Documentation Formats.** Acquisition documentation (OR, DP, MINI-NDCP, TEMP, etc.) format requirements are set forth in OPNAVINST 5000.42A, OPNAVINST 3960.10A, and other directives. The specified format for each of these documents is structured for major weapon system acquisitions; consequently, they are not directly adaptable to the management documentation requirements of training device acquisitions. As presently structured, these documents contain topical areas not applicable to training device acquisitions. They do not address certain topical areas essential to NAVEDTRACOM management functions and to training system design functions. However, basic functional concepts of these documents are applicable to training device acquisitions and must be adhered to in order to conform to established RDT&E acquisition management principles and policies. For these documents to be maximally effective and responsive to the needs of all involved activities, they should either be revised and/or replaced with comparable functional documents. This action is required to:

- maintain the integrity of the training system design process
- ensure consideration of issues peculiar to training device acquisition
- provide data essential to CNET management responsibilities
- permit the NAVEDTRACOM to effectively plan and provide for training device facilities, personnel, and maintenance support in a timely manner
- provide data required to effectively identify and develop training device test and evaluation requirements and strategies.

**RDT&E Organizational Responsibilities and Relationships.** A number of directives attempt to define the RDT&E and acquisition processes and the responsibilities and relationships of various organizations involved in these processes.

## Technical Report 118

These directives span all echelon levels, from DOD to the most junior commands. A comprehensive review of available documents by the study team revealed instances of conflicting and/or confusing responsibility statements, procedural disparities, and a basic lack of continuity. Unfortunately, a single document does not exist that clearly delineates the functions, responsibilities, and procedures of all activities involved in the acquisition of training devices, whether RDT&E or procurement funded. It is recognized that a textbook, lockstep approach cannot be applied to system or equipment acquisitions; flexibility and ingenuity, within the limits allowed by existing policy directives, are recognized factors in the success of any acquisition program. Continual dialogue among participants is another accepted key to acquisition success. Of all these recognized factors to acquisition success, responsibility commensurate with authority along clearly defined chains of command is considered the single most important.

Defining organizational responsibilities and relationships is a complex undertaking, particularly for organizations involved in RDT&E funded training device acquisitions. The unusual, but necessary, Training Agent (TA) - Training Support Agent (TSA) - Developing Agent (DA) organizational relationship is but one example of this complexity. Figure 5 identifies key organizations in RDT&E funded acquisitions. A discussion of the specific assigned RDT&E management roles and responsibilities of these organizations follows. These discussions are by no means exhaustive. They are intended only to highlight certain major fundamental roles and responsibilities relevant to RDT&E funded acquisitions.

The Assistant Secretary of the Navy (Research, Engineering and Systems) has control over RDT&E,N appropriations; responsibility for RDT&E management is delegated to various organizations within the Navy. Responsibility for Research (6.1) is assigned to the Chief of Naval Research (CNR) and responsibility for Exploratory Development (6.2) is assigned to the Chief of Naval Development (CND) who also occupies a position in the Naval Material Command (NMC). The management of Advanced Development (6.3) and Engineering Development (6.4) is delegated to the Chief of Naval Operations (CNO). The Director of RDT&E (OP-098) implements the CNO responsibilities in the Advanced Development and Engineering Development areas. Essentially, there is a matrix organization of Advanced Development and Engineering Development activities with a representative (Development Coordinator) of OP-098 paired with a resource sponsor representative from the appropriate office within the CNO's staff.

Technical Report 118

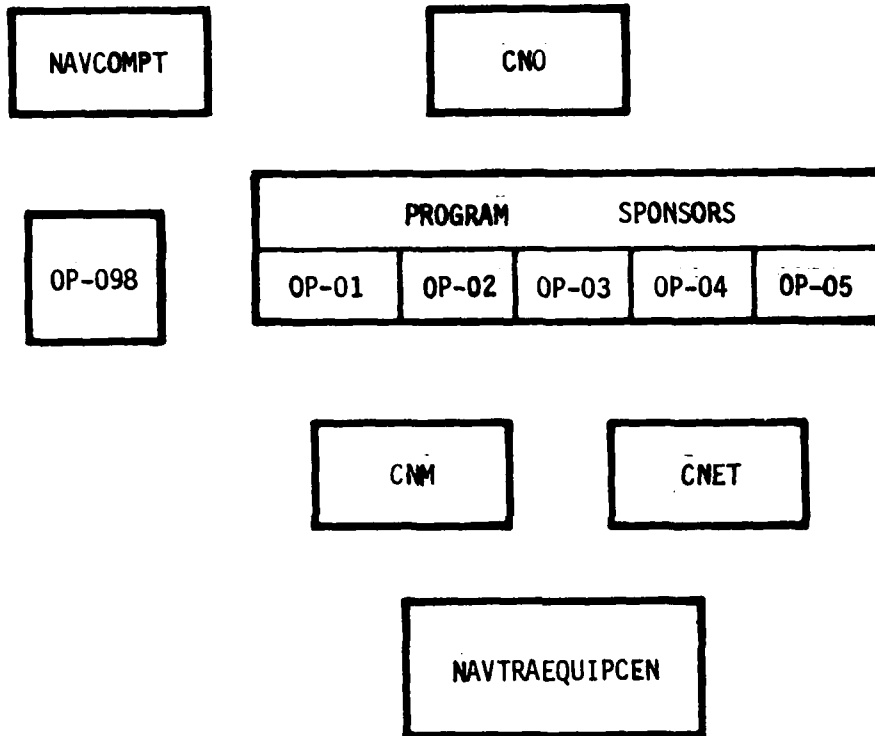

Figure 5. Key Management Organizations in RDT&E Funded Acquisition Programs

## Technical Report 118

**Program Sponsors.** The Navy Programming Manual defines a program sponsor as "The DCNO or Director of a Major Staff Office who, by organization charter, is responsible for determining program objectives, time-phasing and support requirements, and for appraising progress, readiness, and military worth for a given weapon system, function or task." The program sponsors included within the scope of this study are: OP-01, DCNO Manpower, Personnel and Training; OP-02, DCNO Submarine Warfare; and OP-03, DCNO, Surface Warfare. General RDT&E related functions and responsibilities (for specific operational areas) include:

- manage and control acquisition programs
- establish and/or approve requirements
- prioritize requirements
- issue ORs
- select most effective alternatives from those proposed in DP
- approve program initiation document (TEMP or Mini-NDCP as appropriate)
- approve Test and Evaluation (T&E) strategy
- issue production authority
- certify successful prototype demonstration.

OP-29 and OP-39, as resource sponsors for subsurface and surface training device acquisitions, are assisted by various activities in carrying out their many functions and responsibilities. Two groups, the Surface Warfare Trainer Group (SWTG) and the Submarine Trainer Working Group (STWG), contribute significantly to the execution of the program sponsor's responsibilities. Membership of these groups include representatives from CNO, CNM, CNET, NAV-TRAEQUIPCEN, Fleet Commanders, Type Commands, and most major commands and activities with significant interest in the surface/subsurface warfare training device development program. Although there are minor procedural differences among the STWG and SWTG, the basic functions are the same as delineated in their respective charters attached hereto as annexes B and C.

OP-01 serves as program sponsor for RDT&E Manpower, Personnel and Training (MPT) programs. The NAVEDTRACOM role in the MPT RDT&E sponsored programs is set forth in CNETINST 3920.1B; this instruction does not apply to 6.4 (Engineering Development) programs. OP-01 acts as resource sponsor for MPT 6.4 RDT&E projects which are not under surface or subsurface cognizance. Procedures for identifying and executing MPT RDT&E requirements differ in some respects from the procedures used for RDT&E surface and subsurface prototype acquisitions. Two bodies, the Future Training Programs Planning Board (FTPPB) and the Experimental Training Programs Policy Board (ETPPB), have been established to assist OP-01 in the planning, programming, and

management functions associated with MPT RDT&E programs. The NAVEDTRACOM does not administer R&D funds and, therefore, cannot fund such activities. However, through various arrangements, such as the joint CNET-Navy Personnel Research and Development Center (NAVPERSRANDCEN) R&D agreement, education and training R&D efforts are conducted in support of CNET mission responsibilities.

**Chief of Naval Education and Training.** The CNET is one of several training agents (e.g., BUMED and CNAVRES) involved with training equipment. The CNET is responsible for assigned shorebased education and training of Navy, certain Marine Corps, and other personnel in support of the Fleet, Naval Shore Establishment, Naval Reserve, and other activities. The specific functions and responsibilities of the CNET are delineated in OPNAVINST 5450.194; the NAVCOMPT Manual, Volume VII, 075148; and CNETINST 7000.2B. CNETINST 7000.2B addresses surface and subsurface training device responsibilities. Significant CNET functions and responsibilities that relate directly to the RDT&E acquisition process include:

- prepares POM and budget documentation for procurement, support, and update of training devices in RDT&E, OPN, and O&MN appropriations. (Note: CNET is not an administrative agent for RDT&E funds.)
- develops and acquires training devices and material for CNET activities, Fleet Commanders in Chief and certain foreign nations
- manages finances for surface and subsurface follow-on training devices
- ensures timely identification of education and training requirements by participating in review of Development Proposals (DP) and CNO approved ORs and by participating in development of Navy Training Plans
- ensures maximum productivity, efficiency, and effectiveness of assigned education and training programs
- ensures quality of education and training satisfies and responds to fleet needs through analyses and other methods
- provides without reimbursement training equipment and devices required to fulfill training requirements of a particular curriculum and not within cognizance of Material Commands
- participates in development of training device requirements
- provides programming and consideration for all major training devices (prototype and follow-on) including facility requirements, Government Furnished Equipment (GFE) identification and tracking, support personnel, and other O&MN life cycle support costs
- reviews initial training course curricula and instructional material

## Technical Report 118

- implements total training system integrating personnel and subsystem into cohesive and efficient operational capability
- regulates and supervises training programs for military personnel (NAVCOMPT 075148)
- specifies and approves the provisions in contracts which relate to training (i.e., factory training, deliverable items (charts, transparencies, diagrams, films)), technical or instructional publications, and training devices (NAVCOMPT 075148).

The CNET is provided assistance in meeting stated mission responsibilities by various organizations, including Commander Training Command, U.S. Atlantic Fleet (COMTRALANT); Commander Training Command, U.S. Pacific Fleet (COMTRAPAC); Chief of Naval Technical Training (CNTECHTRA); and the NAVTRAEQUIPCEN. These mission responsibilities, as indicated above, are many and varied. In view of these many responsibilities, it is logical to presume that CNET would have firm management control of surface and subsurface training device programs, including prototype RDT&E acquisitions. Unfortunately, as pointed out in the Report of Command Inspection of the Chief of Naval Education and Training Headquarters, 19-30 January 1981 by the Inspector General's office, the lack of management control of RDT&E devices adversely affects CNET's ability to manage development of follow-on devices. Effective management control would include control of budgeting, funding, and execution for the devices. Figure 6 depicts the Department of the Navy Fund Flow Chart as illustrated in the NAVCOMPT Manual 073002. As can be seen from figure 6, CNET is not included among the 11 Administering Offices for RDT&E,N funds. In essence, this situation is in conflict with the management principle of "authority commensurate with responsibility." Various initiatives are underway to have CNET designated as an Administering Office for RDT&E,N funds. At the present time, the results of these initiatives are unknown; however, the management process proposed in section III of this report is designed to provide an affirmative response to these initiatives.

The importance of CNET management control of RDT&E training devices cannot be overemphasized. It is an established fact that prototype training devices significantly influence the engineering design, training capability and resource requirements of the follow-on training device acquisition. Currently, decisions with respect to requirements, syllabus, design, and acquisition are made in the OPNAV-NAVMAT arena. Further, various training analyses, required before and during prototype acquisition, are an important part of the training system design process and must represent CNET interests and responsibilities. Control of related resources is necessary if CNET is to effectively meet assigned responsibilities.



## Technical Report 118

**OP-098 (Director, Research, Development, Test and Evaluation).** OP-098 plays a major role in all Navy RDT&E system acquisition programs (which include prototype training device acquisitions). This role must be recognized in any training device acquisition management process if the basic principles of the RDT&E process are to be adhered to. To illustrate the importance of this role, OP-098 serves as an advisor to the Assistant Secretary of the Navy, Research, Equipment and Systems (ASN (R, E&S)) and assists the ASN (R, E&S) with respect to coordination, integration and direction of Navy RDT&E programs including appraising the progress of RDT&E efforts and recommending projects for curtailment, suspension or cancellation as appropriate. Specific OP-098 functions and responsibilities include:

- exercises specific responsibilities for financial administration and control of RDT&E,N operating budget allocations
- exercises Test and Evaluation (T&E) policy and guidance in accordance with overall policies of the Secretary of the Navy
- implements CNO's responsibilities for planning, programming, and progress appraisal of RDT&E efforts
- acts for CNO as sponsor for the appropriation RDT&E,N
- manages planning and reporting procedures for RDT&E programs
- supervises formulation of Navy Program Objectives and annual budget for RDT&E
- reviews ORs and TEMPs
- acts as OPNAV focal point for NDCPs and DCPs
- promulgates NDCP or equivalent document
- communicates CNOs RDT&E decisions to Chief of Naval Materiel (CHNAVMAT), Bureau of Medicine and Surgery (BUMED), and Operational Test and Evaluation Force (OPTEVFOR)
- provides policy guidance to and exercises technical direction of COMOPTEVFOR in matters relating to RDT&E
- approves waivers for T&E for ACAT II and ACAT III programs.

**Navy Comptroller (NAVCOMPT).** The NAVCOMPT allocates funds to the CNO and to other responsible officials within the Navy. An overview of the funding flow within the Department of the Navy is shown in figure 6. The NAVCOMPT also evaluates from a budgetary and financial viewpoint, the POM regarding:

- appropriations and fiscal status and implications
- financial feasibility and balance
- validity in relation to planned objectives
- legality.

## Technical Report 118

**Chief of Naval Material.** The CHNAVMAT and subordinate activities are charged with many RDT&E responsibilities and functions, including design and development of training equipment and materials. The role and responsibilities of the activities under the CHNAVMAT as Training Support Agent (TSA) are defined in the NAVCOMPT Manual 075148 and will not be repeated here. Responsibilities and functions related to RDT&E system acquisition and training include:

- manages technology base development
- develops detailed plans for RDT&E projects for satisfying approved requirements for systems/equipments
- supervises planning, execution, and appraisal of development, test, and evaluation programs
- responsible for initial training
- provides as TSA, initially usable item(s) of training equipment and instructional materials
- prepares DPs in response to approved ORs
- assists in review of T&E portion of major documents such as the DCP and TEMP
- forwards NDCP or equivalent document to performing activity
- provides T&E coordination
- advises CNET of all NAVTRAEQUIPCEN taskings.

As described in the NAVCOMPT Manual and other policy directives, the TSA is responsible for providing initial training for new systems and equipment and the Training Agent is responsible for replacement and follow-on training. The NAVTRAEQUIPCEN is under the operational control of the CNET (TA); however, the CHNAVMAT relies heavily on the NAVTRAEQUIPCEN in carrying out the CHNAVMAT TSA responsibilities. As set forth in NAVMATINST 5450.28/CNETINST 5450.8, the NAVTRAEQUIPCEN is assigned additional duty "to perform functions in support of the CHNAVMAT, the Systems Commands (SYSCOMs), and the Project Managers (PMs) in the development, acquisition and logistics support of training devices." This same instruction also indicates that the capabilities of the NAVTRAEQUIPCEN for training device development, acquisition, and life cycle management will be made available to the Fleet Commanders and to BUMED. A sophisticated and complex management control situation clearly exists. Although NAVMATINST 5450.28/CNETINST 5450.8 set forth broad guidance relative to the CNET-NAVMAT-NAVTRAEQUIPCEN management relationship, it is lacking in specificity in many areas, such as tasking procedures, review and approval authority, and documentation requirements and processing procedures.

**Naval Training Equipment Center.** The NAVTRAEQUIPCEN is recognized as the Navy's primary technical agent for training devices. In this capacity it provides technical support to the CNET, CHNAVMAT, DCNO surface warfare, DCNO submarine warfare, DCNO (MPT), and other activities through the planning and execution of projects for development of training material. These projects include exploratory development, advanced development, engineering development, and operational development. Specific functions and responsibilities as derived from CNETINST 5450.31A and other directives, include:

- perform functions in support of CNET, CHNAVMAT, SYSCOMs, PMs, and other activities in the design, development, acquisition, and logistics support of training devices and equipment
- identify resource requirements for training device initial spares, modification, and factory training
- assist CNET and functional commanders in initial analysis of training device needs
- perform technical assessment of training device feasibility, cost, approaches and alternatives.
- provide facility, personnel and OPTAR requirement criteria to functional command training activity
- participate in STWG and SWTG functions
- perform training device engineering development functions including front-end analysis, planning, engineering, logistics, and contracting
- perform equipment test and evaluation
- conduct training research (in-house and contract)
- establish functional baseline
- develop Program Master Plan
- develop POM justification data.

**TEST AND EVALUATION (T&E) REQUIREMENTS.** Test and evaluation is an integral part of all phases of the RDT&E acquisition process for systems and equipments. Test and Evaluation policy, requirements, and procedures are specified in various directives including DODDIR 5000.1, DODDIR 5000.3, SECNAVINST 5000.1, and OPNAVINST 3960.10. These directives apply to all RDT&E funded system and equipment acquisitions, including training device acquisitions. However, as will be discussed later, these directives do not provide for certain factors characteristic only to training device acquisitions.

## Technical Report 118

Basically, T&E includes the deliberate and rational generation of data concerning the emerging system or equipment and the creation of information which is used by technical and management personnel responsible for development. It includes physical testing, experimentation, and analyses performed during the course of research, development, introduction, and deployment of the system or equipment, and all evaluative studies performed using the data generated. Test and evaluation provides key information for a number of purposes and different information users. Included in these purposes are:

- Information for Development. Includes information provided by various tests conducted by the Government which is useful in the design-test-evaluation-redesign process which is basic to the development of a reliable and effective system or equipment.
- Information for Acquisition Milestone Decisions. Includes information required by management for many of the major milestone decisions in the life of an acquisition program, such as decisions to initiate development, to conduct full scale development, or to procure a system for inventory. The decision makers, such as the OPNAV Resource Sponsor, are responsible for putting available resources to their most productive use. As a basis for these decisions, T&E must provide information concerning the utility of the prospective system, its operational effectiveness, operational suitability, training effectiveness for training devices, and data useful to management in estimating the probable cost of completing development, acquisition, and ownership.
- Information for Effective Operational Utilization. The operating forces, both Fleet units and training activities, are users of information developed through test and evaluation. One output of operational test and evaluation is the development of procedures and doctrine for the most effective utilization of the system or equipment.

**Test and Evaluation Policy.** The fundamental T&E policy calls for a development strategy based on performance demonstrations. The resource sponsor ensures that adequate resources are allocated so that the demonstration of actual achievement of program objectives is the pacing function. Another basic policy for T&E which provides information for acquisition milestone decisions is that of the independent evaluation. This policy requires that an organization with a vested interest in "selling" the system under development not have unilateral control of the establishment of test requirements, the conduct of tests, or evaluation of results. The using activity and the "buyer" of the system or equipment (i.e., OPNAV Resource Sponsor) must have access to independent evaluation of test results. Independent test agent is defined as a command or agency independent of the developing, procuring, and using commands. The principle of independent evaluation has always been fundamental to Navy development procedures. COMOPTEVFOR serves as the Navy's independent operational T&E activity for new systems and equipment. However, as indicated in Cordell, Nutter, and Heidt (1979), COMOPTEVFOR will participate in only those training device T&E programs wherein the training device interfaces directly with an operating system platform (e.g., the Pierside

Trainer). Policy requires that no new system or equipment or significant alteration to an existing system or equipment may be approved for production until it has been adequately tested, proved operationally suitable and found to be logistically supportable.

**T&E Categories.** Figure 7 presents the general role of T&E for major systems and equipment throughout the acquisition process. Test and Evaluation for major systems acquisitions is composed of two categories, Development Test and Evaluation (DTE) and Operational Test and Evaluation (OTE). For training devices, there is a third category, the Training Effectiveness Evaluation (TEE). All categories of T&E are divided into specific phases. These phases are described in Cordell, et al. (1979) and various DOD directives.

**Development Test and Evaluation (DTE).** This is conducted by the developing agent and required for all acquisition programs to:

- demonstrate that the engineering design and development processes are complete
- demonstrate that design risks have been minimized
- demonstrate that the system meets specifications
- estimate the systems utility when introduced.

TEE results are normally reported to CNO via CHNAVMAT.

**Operational Test and Evaluation (OTE).** This is conducted by an independent test agency to estimate the prospective systems utility, operational effectiveness, operational suitability (including compatibility, interoperability, reliability, maintainability and logistic and training requirements), and need for modification. Also, it may be used to provide data to support or verify the adequacy of material in operating instructions, publications, and handbooks. In the training community, the term Training Capabilities Tests (TCT) is currently being used in lieu of OTE. Operational Test and Evaluation results are normally reported directly to CNO/CMC.

**Training Effectiveness Evaluation (TEE).** An independent test agency conducts the TEE to assess (i.e., evaluate) a training device's potential or actual value for achieving/facilitating achievement of specified training device objectives. Training Effectiveness Evaluation results are reported to the TA.

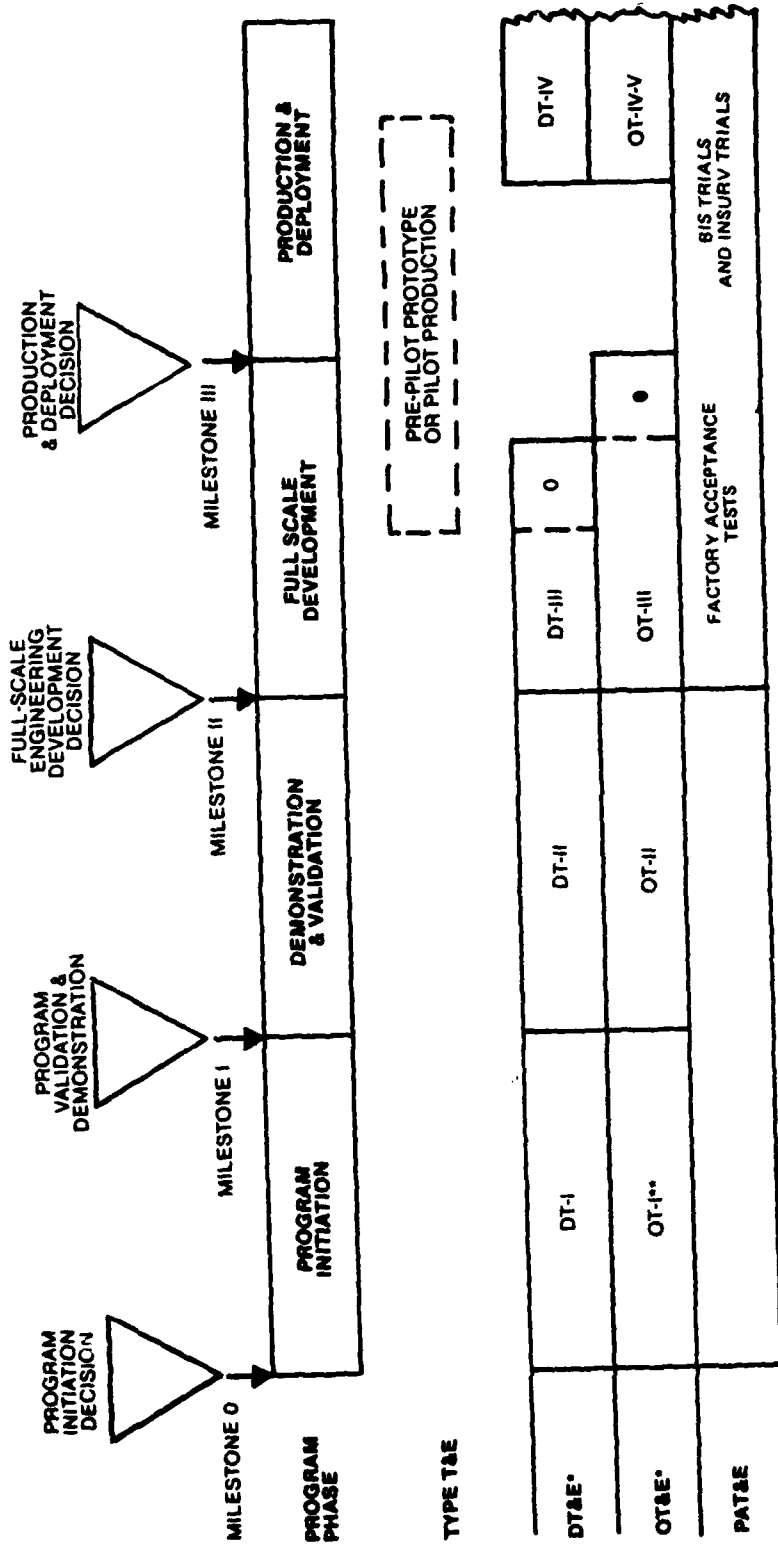

0 TECHEVAL  
 ● OPEVAL  
 \* ALL T&E MAY BE FURTHER DIVIDED INTO SUB PHASES e.g., DT-III.A, O-III.B, etc.  
 \*\* NOT REQUIRED FOR MOST ACQUISITION PROGRAMS

(Source: NAVSO P-2457 (Rev. 12-79))

Figure 7. Test and Evaluation Phases

**T&E Procedures.** Various activities within the NAVEDTRACOM have expended considerable effort to develop training device T&E procedures which parallel the formal procedures established for major system acquisitions and adhere to the principle of RDT&E acquisition policy directives. Examples of the initiatives taken are described in the following:

- TAEG Report No. 71 (Cordell, et al., 1979) which includes a proposed OPNAV instruction for the Test and Evaluation of Navy Training Devices procured under RDT&E funding
- draft description of procedures for conducting training effectiveness evaluations of training devices prepared by TAEG at the request of CNET (CNET ltr Code N-53 of 13 Dec 1979)
- draft CNET instruction for test and evaluation procedures for RDT&E Training Device Development prepared by the NAVTRAEQUIPCEN at the request of CNET (CNET ltr Code N-34A of 6 Nov 1979).

Despite the initiatives enumerated above, there are, at present, no formal policy directives which establish clearly defined procedures for training device T&E. Whereas several T&Es for training devices (i.e., Device 19F1 and Device 11B106) are underway, the "ways" and "means" by which these programs are developed differ significantly due to lack of T&E policy and guidelines for training devices. Such policy direction is clearly needed to establish T&E standardization, review-approval authority, funding responsibility, support responsibility, documentation requirements, and overall operating procedures for training device T&E.

The earliest known documentation related to training device T&E was indicated in CNO (OP-987) memorandum of 30 Dec 1977 which requested the CNET to develop within its resources a capability for independent evaluation of training devices. This task is clearly a difficult one, particularly in view of the short lead time given to training device acquisitions and the requirement to avoid serious disruption of required training.

It is essential that T&E procedures for training devices procured under RDT&E be developed which conform to the basic requirements of RDT&E instructions and do not create training delays or excessive costs. Further, it is essential that these procedures permit the CNET to perform his mission and function of ensuring the training effectiveness of all training aids and devices. The measure of excellence of a training device is how well it trains--reasonable opportunities to make this determination must be allowed. Test and Evaluation policy procedures for training devices should include but not be limited to:

- documentation requirements
- documentation processing
- review/approval activities
- funding responsibilities
- organizational responsibilities
- planning procedures

## Technical Report 118

- T&E results reporting requirements
- T&E decision milestones
- T&E methodologies (each category)
- T&E coordination procedures and responsibilities.

### TRAINING EQUIPMENT ACQUISITION MANAGEMENT CONSIDERATIONS

**MAJOR WEAPON SYSTEMS.** The majority of high cost training devices are acquired to support a major weapon system or equipment. Consequently, the training equipment acquisition process, including the necessary planning, programming, and budgeting functions, is dependent in a large part upon the occurrence of certain events and milestones in the weapon system or equipment acquisition process. The relationship between the two acquisition processes is unusually complicated. This complexity may be attributed to a variety of factors, the primary being:

- number of organizations involved
- organizational responsibilities
- type training requirements
- programming/budgeting requirements
- training system design requirements
- time constraints.

Of the six factors enumerated above, time is viewed by the majority of personnel involved in training device acquisitions to be the most critical because of its influence on so many acquisition-related activities. Since time is a convenient "common denominator," it is frequently used in describing the relationship of the training equipment acquisition process and the major weapon system acquisition process. Traditionally, this relationship is described in terms of relative time related events with the major system acquisition events being the pacing functions for the training equipment acquisition process.

**TRAINING SYSTEM DESIGN.** The training equipment acquisition process is typically viewed as being supported by the training system design process which is, in the present report, considered analagous with the intent of Instructional System Development (ISD). The traditional view taken of the relationships of the two acquisition processes and the training system design process is represented by the following block diagram.

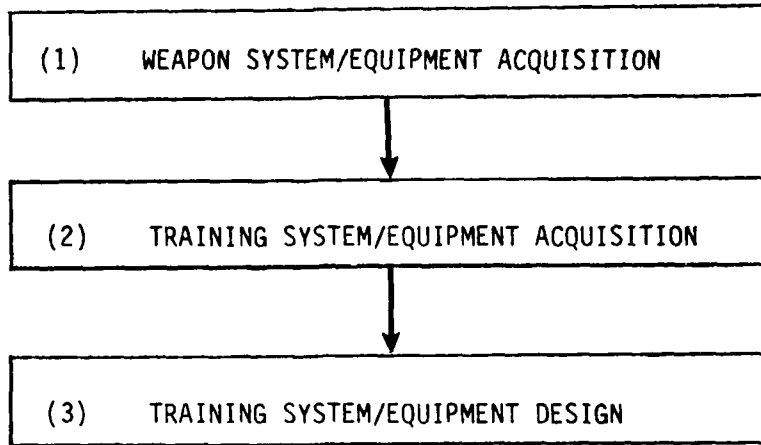

Technically, from a training system design viewpoint, the block sequence is incorrect; blocks 2 and 3 should be reversed with training system equipment acquisition serving in a support role to the training system design process. Simply stated, the training equipment acquisition process merely serves as the mechanism for accomplishing a specific task (i.e., acquire a training device) in the training system design process, determined to be the best solution to a stated training requirement, through a series of systematic front-end analyses and activities stipulated in the process.

The five major phases of the training system design process are shown below.

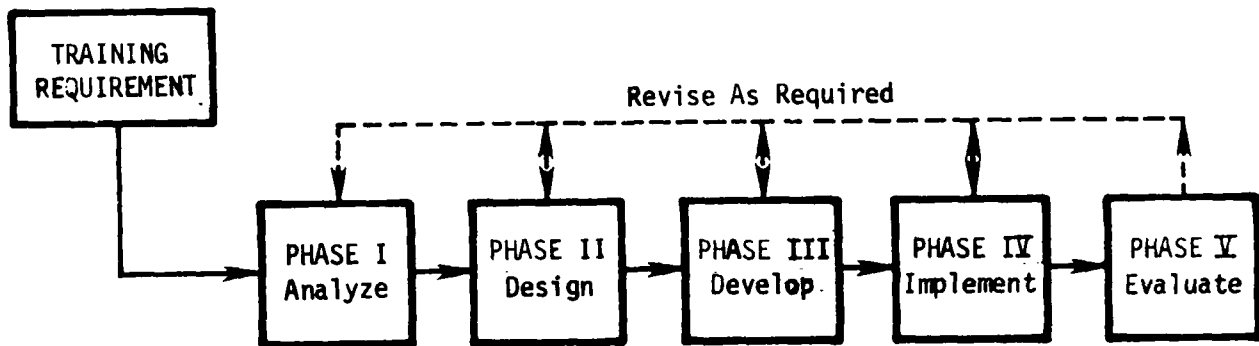

Theoretically, it is not known until the develop phase in the process is reached that a training device, and hence the acquisition of the device, is required. It is apparent, from an OPNAV and CNET management responsibility viewpoint, that this is not an acceptable point in time (relative to the weapon system acquisition) to begin the necessary training equipment acquisition programming, budgeting and planning functions. Practical compromises to the rigid requirements of the training system design process (which do not adversely affect the outcomes but do reduce the time requirements of the process) coupled with innovative management procedures are clearly required to contend with the "real world" time limitations associated with most training device acquisitions.

**ACQUISITION AND PROCUREMENT.** In discussing the various acquisition relationships, it is important to understand the difference between acquisition and the commonly used term procurement. These two terms are defined as follows (underlining added for emphasis):

ACQUISITION - The process consisting of planning, designing, producing, and distributing a weapon system/equipment. Acquisition in this sense includes the conceptual, validation, full-scale development, production, and deployment/operational phases of the weapon systems/equipment project. For those weapon systems/equipments not being procured by a project manager, it encompasses the entire process from inception of the requirement through the operational phase (NAVMAT 4000.20).

PROCUREMENT - Includes purchasing, renting, leasing, or otherwise obtaining supplies or services. It also includes all functions that pertain to the obtaining of supplies and services, including description but not determination of requirements, selection and solicitation of sources, preparation and award of contracts, and all phases of contract administration (DOD 5126.34).

**TIME ISSUES.** Two critical time constraints are, from a practical standpoint, not likely to be subject to change. They are (1) that time point in the weapon system acquisition cycle when the training equipment must be onsite and ready for training (RFT) and (2) the time required to complete the programming and budgeting cycle. The weapon system or equipment program manager normally establishes the training equipment RFT date. This date must be met if trained personnel are to be available to operate and maintain the system or equipment when delivered and if CNET is to meet pipeline training requirements. Failure to meet the RFT date severely restricts the capability of the operational forces to meet their mission commitments.

## Technical Report 118

For major training device (prototype) programs, OPNAVINST 1500.8 states that the minimum lead times required to meet RFT dates are (1) 5 years for military construction projects, (2) 4 years for major training devices, and (3) 3 years for billets and expense dollars. Historical evidence suggests a 5-year phasing between POM input and training device RFT for major prototype RDT&E devices to be more realistic. The NAVCOMPT Manual 075148 states that follow-on devices can only be programmed in years subsequent to the successful demonstration of the prototype unit. The CNO resource sponsor determines what constitutes a successful demonstration. This may take place at the prototype RFT date or 1 year prior at design approval. These programming and budgeting time requirements place severe limitations on the time available to perform the various training system design analysis functions required prior to identifying the training device requirement. Technically, these analyses are performed prior to the POM submission, a period when technical details relating to the weapon system or equipment are typically minimal. From a practical standpoint then, data necessary to complete all of the stipulated tasks prior to initiating the training device acquisition process are not available when required. Therefore, modified analyses, based on earliest information available and made progressively more definitive as the weapon system or equipment program progresses, should be used for initiating training equipment acquisition programs (i.e., POM submittal).

Another factor related to front-end training analyses concerns the availability of funds, often required for the conduct of such analyses. Due to manpower limitations and commitments, front-end analyses cannot always be conducted in-house; contractor effort is sometimes required to support front-end training analyses efforts. The present procedure for POM submission for prototype training device acquisition is not sufficiently early to provide funds for all required front-end training analyses. Therefore, a possible solution to this dichotomy is to submit initial RDT&E budget submissions coincidental with hardware Milestone 1. These submissions can be updated on an annual or on an as-occurring basis. Authority to expend would be granted when the decision is made that a new training device is required to satisfy the training need.

**TRAINING SYSTEM DESIGN REQUIREMENTS.** The training system design process begins with the statement of a training requirement, a statement which is too often presented as a solution rather than a requirement. This problem of stating training requirements was addressed in Sands and Glaser (1978). It was noted that:

- Operators do not do a good job of stating requirements, tending to be too global, to ask for things that already exist, and to specify solutions rather than problems.
- The process of formulating requirements is complex and requires ongoing dialogue between users and producers.
- There is need for careful planning of end products and their implementation, beginning early in the research program and frequently iterated.

- Users fail to take advantage of opportunities for prototype development.

The points enumerated above are sound reasons why emphasis should be placed on the procedures for identifying training needs, not necessarily training device requirements. In effect, the acquisition process drives the training system design process, which is counter to the fundamental principles of instructional systems design. The problems associated with this situation could be reduced or eliminated by beginning the required training front-end analyses early in the weapon system or equipment acquisition cycle. The results of such analyses would be recorded in a series of documents specifically structured to address the mission functions of the CNET and the documentation requirements of the RDT&E process. In essence, these early documents could serve as the basis for early budget submissions and the building blocks (functional baseline) from which formal RDT&E documentation (i.e., OR, DP, NDCP comparable documents) could be derived in a timely manner. This concept would permit the basic functions of the training system design process to be performed and ensure CNET participation in the development of training system requirements. In order for this concept to succeed, it is mandatory that CNET have early access to, and management control of, RDT&E funds.

**TIME CONSTRAINTS ON FRONT-END ANALYSIS.** As previously discussed, front-end analyses form a fundamental part of the RDT&E process for major system and equipment programs. The requirements for front-end analyses are just as applicable to training device RDT&E programs as to major system and equipment RDT&E programs. The basic differences lie in the types of analyses and the time available for such analyses. Major system and equipment programs may logically progress through the various RDT&E phases with sufficient time allocated for required conceptual and front-end analyses. Because of the time constraints associated with current training device acquisition procedures, training device requirement statements are frequently substituted for training need statements and considered as justification to eliminate basic front-end training analysis. This practice can lead to training devices which are either over or underdesigned in terms of training efficiency.

The concept of initiating front-end training analyses at Milestone 1 for major system and equipment programs is illustrated in figure 8. It should be noted that due to the state of change in planning documentation, the old planning documents for RDT&E programs are used. Figure 8 illustrates the general management functions and activities involved with initial training and follow-on/replacement training relative to key events in the major system or equipment life cycle. The general concept presented in figure 8 is addressed further in section III of this report.

#### **SUMMARY OF FINDINGS**

The decision that first article (prototype) training devices would be developed using RDT&E appropriations requires that training device acquisition programs adhere to the fundamental principles of the RDT&E process

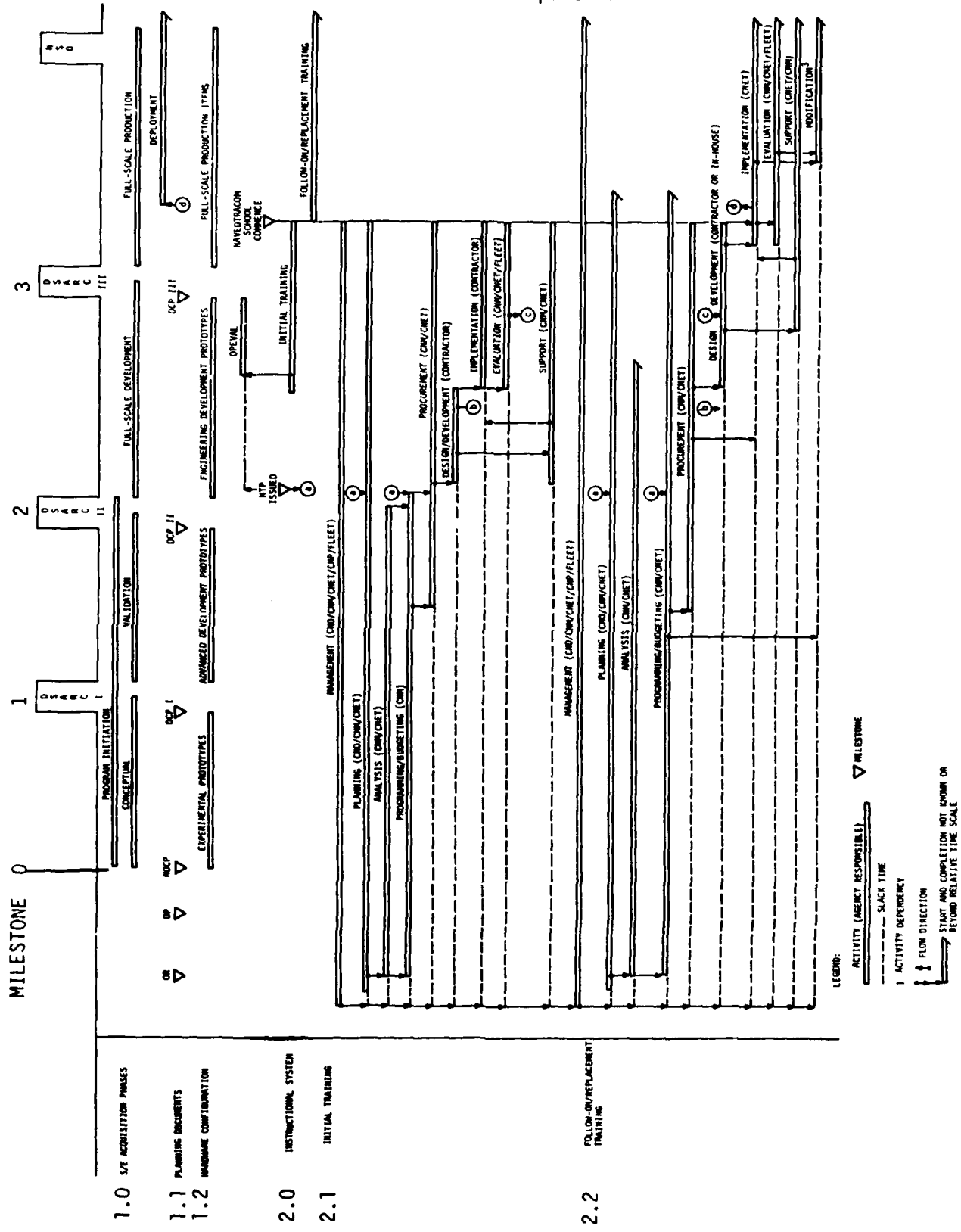

Figure 8. Life Cycle of Instructional System

## Technical Report 118

as set forth in DOD and SECNAV policy directives. These directives permit, and encourage, management flexibility and innovation and advocate authority commensurate with responsibility; they are, however, structured for major weapon system acquisition programs.

Although the RDT&E process was conceived for managing major weapon system development programs, it is adaptable to training system acquisition programs. To be completely successful for surface and subsurface training device acquisition programs, this adaptation must include changes in CNET management posture, functions, and procedures. The RDT&E process has not yet been fully adopted by the training community because:

- training device development procedures differ from weapon system development procedures
- existing RDT&E directives and instructions are not directly transferrable to training system design requirements
- time constraints associated with the weapon system and equipment development cycle and the training equipment acquisition cycle
- CNET management authority and financial controls not commensurate with assigned responsibilities
- current RDT&E program documentation not adequately reflecting training system design and acquisition programming requirements.

Adapting the RDT&E process to the training device acquisition process represents a tremendous potential for innovative training and cost effective solutions to training problems. The first step in developing this potential is to design a workable training system acquisition management system that conforms to the principles of the RDT&E process and accommodates the responsibilities peculiar to the training community. Such a management system, which includes identifying management documentation requirements and review/approval responsibilities, is presented in section III of this report.

Because of the complexity of the topics, there is understandable confusion among many responsible for various areas of training device acquisition regarding the relationships among RDT&E, training device acquisition, training system design, and the programming and budgeting processes. Existing instructions and directives, of which there are many, are too often vague or in conflict with each other and, consequently, contribute little to the understanding of these topics. The generic management system proposed in section III will not in and of itself answer all questions relating to a Training Research, Development, Test and Evaluation (TRDT&E) process; answers to such questions can only be provided in a single document (i.e., RDT&E Management Guide) tailored expressly for that purpose for the training community.

### SECTION III

#### PROPOSAL FOR THE MANAGEMENT OF RDT&E SURFACE-SUBSURFACE FIRST ARTICLE TRAINING DEVICE ACQUISITIONS

This section presents a summary of the various ongoing initiatives in RDT&E management and addresses specific training community issues not adequately provided for under existing RDT&E directives. The application of the RDT&E process to first article surface and subsurface training device acquisitions is also described. This description includes, among other topics, suggested new documentation requirements and management review procedures. The management system proposed conforms to the basic principles of the RDT&E process and is applicable to 6.3 and 6.4 training device acquisitions.

#### ONGOING RDT&E RELATED INITIATIVES

The specifics of the RDT&E process are undergoing considerable change, and new documentation is available. Two documents affecting RDT&E are in draft form:

- Management of Manpower, Personnel and Training Research, Development, Studies and Surveys. (CNO OP-115)
- CHNAVMATINST 5450, subj: additional duty functions of the Commanding Officer, NAVTRAEQUIPCEN, to CHNAVMAT and relationships between NAVTRAEQUIPCEN and Systems Commanders, Project Managers, and others.

Four documents have been published during 1981:

- CNETINST 3920.1B (August 1981), subj: Research, Development, Test and Evaluation Program for the Naval Training Command.
- CNETINST 7000.2B (November 1981), subj: Policy, Responsibilities, and Procedural Guidance for the Planning and Resource Requirement Identification for Surface and Subsurface Training Devices.
- OPNAVNOTE 5000 (June 1981), subj: Reduced Documentation Requirements for the Acquisition Process.
- NAVMATINST 1500.12 (April 1981), subj: Technical Training Equipment Acquisition Requirements.

The Training Device Acquisition Management System presented in this section describes the proposed training RDT&E process. No attempt has been made to portray an "ideal" RDT&E process. Rather, the attempt is to compile in a single document training versions of documentation required by DOD and proposed documents required for implementation within the training community. Every attempt has been made to support the intent of DOD RDT&E policy and the latest interpretations of that policy as reflected in the documentation cited above.

## **RDT&E WITHIN THE TRAINING COMMUNITY**

Navy RDT&E was originally conceived for managing operational weapon systems and equipment development projects. Department of Defense, SECNAV, and most OPNAV and NAVMAT documents describe and define RDT&E in language relevant to weapon systems. The RDT&E process as defined in these documents is interpretable for use in developing and acquiring a training device, but RDT&E does not, in its present form, compel the developer to emphasize training requirements. The training device developer, involved in the routine functions necessary to acquire a device, is apt to meet only the administrative requirements subject to review in the RDT&E process. The process for the development of devices with training capabilities is quite different from that required for weapon systems. For example, it is a relatively simple matter for experienced pilots to specify the speed, range, maneuverability, and firepower required in a new aircraft. Much more complex analysis is required to isolate and specify the training requirements for that aircraft. Clearly, if training device developer efforts are to be directed toward effective training design, RDT&E instructions must be revised to reflect training needs.

CNET instructions and some OPNAV and NAVMAT instructions reflect an effort to adapt the weapon system oriented RDT&E process and terminology for use in the training community. For example, the Training Equipment Test and Evaluation Plan (TETEP) is the training community's version of the Test and Evaluation Master Plan (TEMP). Presently, the title distinction is all that distinguishes many training document requirements from those for weapon systems. Training device developers must interpret and modify weapon system oriented RDT&E documentation requirements to meet training needs. Since the quality and quantity of training oriented documentation varies with the background and interests of the developer, training community RDT&E documents should be developed which would promote uniformity and completeness in the conduct of training analyses.

## **PROPOSED TRAINING DEVICE ACQUISITION MANAGEMENT SYSTEM**

The training device acquisition management system proposed here complies with the basic RDT&E management principles set forth in DOD Directive 5000.1 and derivative documents. The system provides for active involvement of the training command, includes the principal participants involved in the RDT&E training device acquisition process, and identifies their respective management functions (i.e., review, approve, promulgate). Documents structured and sequentially processed specifically for first article training device acquisition programs serve as the fundamental building blocks and management tools for the system. A series of 20 events are identified as appropriate to translating training needs into efficient and effective training devices.

Each event, from training need identification to completion of training effectiveness evaluation (if required), and each document is described in subsequent paragraphs. The titles of the events and documents correspond to those used in figure 9 (page 53). Where appropriate, specific approval or review functions are indicated; most documents are described in general functional terms as their specific format and content is still in development.

A comprehensive listing of reference documentation (with area(s) of application indicated) used in developing the training device acquisition management system is provided in annex D. In addition, figure 9 is provided as a foldout at the end of this section as a ready reference to subsequent discussions.

**EVENT 1 ACTIVITY.** Training device requirements are formally documented by the Navy Training Plan (NTP) (CNETINST 1500.9; OPNAVINST 1500.8H) and the development plans of major weapon systems (CNETINST 7000.2B). In addition, any fleet activity or Navy command may identify a training requirement and submit it to the appropriate Warfare Sponsor in the form of a documented Training Requirement Statement (TRS) via the chain of command (CNO memo 987/644701; OPNAVINST 5000.42A). Naval Education and Training Command activities submit TRSs directly to CNET for submission to CNO. Activities not under the command of CNET submit TRSs to the cognizant warfare code resource sponsor (CNO OP-01, 02, or 03) with a copy to CNET. CNO (OP-05) is excluded from consideration in this report in compliance with the CNET tasking instructions.

Chief of Naval Operations (OP-01) Manpower, Personnel, and Training, is primarily concerned with 6.1 (Research), 6.2 (Exploratory Development), and 6.3 (Advanced Development) categories of RDT&E. Chief of Naval Operations (OP-02 and 03) are primarily concerned with 6.4 (Engineering Development) and occasionally the 6.3 category of RDT&E. Chief of Naval Operations (OP-01) typically serves as resource sponsor for 6.3 and 6.4 category projects that cut across warfare code lines. For example, CNO (OP-01) was the resource sponsor for the Advanced Fire Fighting Simulator, a project of concern to both CNO (OP-02 and 03). Chief of Naval Operations (OP-01) is also the resource sponsor for CNET projects which do not fall under the cognizance of CNO (OP-02 or 03) (CNETINST 3920.1B).

**DOCUMENT 1.1 TRAINING REQUIREMENT STATEMENT (TRS).** The TRS is a proposed document modeled after the Mission Element Need Statement (MENS)(DODDIR 5000.1). Training Requirement Statements are concise statements of current or anticipated training deficiencies or needs that have a high perceived probability of solution with the use of some type of training aid or device. The purpose of the TRS is to articulate the deficiency or need, define the course elements or objectives requiring support, and predict impact.

**EVENT 2 RESOURCE SPONSOR.** The resource sponsors (CNO OP-01, 02, or 03) are the terminal points within the chain of command for TRSs submitted by fleet activities or Naval commands. Chief of Naval Operations (OP-01, OP-29 (as the training representatives of OP-02), and OP-39 (as the training representative of OP-03)) contact the submitting activity for additional information and amplification as required and establish priorities for TRSs submitted under their respective cognizance. Chief of Naval Operations (OP-29) as a co-chairperson of the Submarine Trainer Working Group (STWG) and OP-39 as a co-chairperson of the Surface Warfare Trainer Group (SWTG), sponsor the TRSs applicable to their respective warfare area groups.

**EVENT 3 SWTG AND STWG.** The SWTG or STWG determine the initial acceptability of the TRS for further development. Since it does not have an advisory group corresponding to the SWTG and STWG, OP-01 performs the actions included in Event 3 for OP-01 projects. Screening of the TRSs is based on the following factors:

## Technical Report 118

- validity of the requirement (i.e., does the requirement address a training need or some other?)
- potential alternative solutions (i.e., does a device seem to be the most appropriate? Could operational equipment be modified as Technical Training Equipment (TTE)? Is there a simpler solution?)
- technological risks
- priority of requirement.

The SWTG and STWG informally task CNET to proceed with analysis and development of the requirement as stated in the TRS; formal tasking is subsequently provided by the appropriate resource sponsor. The SWTG and STWG monitor progress through regular reports at the spring and fall meetings. Training Requirement Statements are normally submitted at the fall meetings for inclusion in the next POM; however, they may also be submitted by Executive Committee members at the spring meeting. Although in the latter instance the time available for front-end analysis and required documentation makes inclusion in the next POM very difficult (SWTG Guidelines and STWG Guidelines (annexes B and C)). It is essential that TRSs be submitted as soon as a training requirement or need is perceived, at approximately Milestone 1 for new weapon system or equipment acquisition programs, to ensure sufficient time and funds for required front-end analyses.

**EVENT 4 CHIEF OF NAVAL EDUCATION AND TRAINING (CNET).** Chief of Naval Education and Training, as training agent, is concerned with training effectiveness, installation, support, and operation of devices. Chief of Naval Education and Training tasks (Event 4A) the Analysis Agent (AA), normally the NAVTRAEQUIPCEN, to perform a preliminary front-end analysis related to the needs addressed in the TRS. The AA, working with the advice and input of concerned activities (Event 4B), provides for the performance of the analysis and submits to CNET a Training Requirement Needs Analysis (TRNA) for review and approval.

**DOCUMENT 4.1 TRAINING REQUIREMENT NEEDS ANALYSIS (TRNA).** The TRNA is a proposed document modeled after the intent of the Milestone 0 decision point (DODDIR 5000.1). The TRNA, performed by the AA, serves as the baseline document for development of subsequent program documents. The primary objective of the TRNA is to provide a preliminary assessment of the training situation including: a statement of the training problem, training objectives, tentative solution (which may include a training device), and budget estimates. The TRNA is not expected to be a definitive statement of specifications; however, sufficient information regarding identifying curriculum, general task analysis and technical data, projecting anticipated student loading, probable training device manpower and Military Construction (MILCON) requirements (where applicable), and identifying technological risks must be included in order to determine whether to proceed to the next developmental step. The TRNA should also include a recommendation to CNET regarding the advisability of exercising the option to require a Training Effectiveness Evaluation (TEE) (see Event 20). It should be noted that each document subsumes the previous document and provides more information appropriate to the decision whether to proceed to the next step in the development process.

**EVENT 5 RESOURCE SPONSOR.** The TRNA is submitted by CNET to the resource sponsor (CNO OP-01, 29, or 39). Resource sponsor approval of the TRNA signifies establishing the training requirement and commits resources to formally develop a Training Operational Requirement (TOR). Resource sponsor criteria for approval include: validity of training requirement, perceived need for a solution, priority of the training requirement, and funding availability.

**EVENT 6 CHIEF OF NAVAL EDUCATION AND TRAINING (CNET).** The resource sponsor tasks CNET to prepare a TOR. Normally, the TOR would be prepared by the AA (Event 6A) and forwarded to CNET for concurrence. The TOR is submitted in draft form to the resource sponsor for official issue.

**DOCUMENT 6.1 TRAINING OPERATIONAL REQUIREMENT (TOR).** The TOR is the proposed training device version of the Operational Requirement (OR). The TOR (not to exceed three pages) is a concise statement of training needs. It is the basic requirement document for all Navy training acquisition programs requiring research and development effort (OPNAVINST 5000.42A; OP-098 memo ser. 987/644701, April 11, 1980). The TOR directs CHNAVMAT to prepare a Training Decision Alternatives Proposal (TDAP).

**EVENT 7 RESOURCE SPONSOR.** The OPNAV resource sponsor approves the TOR and issues it (Document 7.1) with a request for development of a Training Decision Alternatives Proposal (TDAP). The request is issued to CHNAVMAT (Event 8); however, the responsible agent is CNET (Event 8A).

**EVENT 8 CHIEF OF NAVAL MATERIAL (CHNAVMAT).** Because training requirements are different from those of weapon systems, CHNAVMAT has designated NAVTRA-EQUIPCEN, under the command of CNET, to serve as AA to plan and execute projects for developing training material (Joint NAVMATINST 5450.28, CNETINST 5450.8). The AA prepares the TDAP for CNET concurrence and submission to the resource sponsor via the CHNAVMAT.

**DOCUMENT 8.1 TRAINING DECISION ALTERNATIVES PROPOSAL (TDAP).** The TDAP is the proposed training community version of the Development Proposal (DP). The TDAP subsumes the TRNA and contains updated information and more in-depth analyses related to those elements which describe the alternate solutions and trade offs designed to achieve a particular range of capabilities in response to the TOR. Cost-benefit data and technical considerations are provided to assist the resource sponsor in selecting from among the specified alternatives (OPNAVINST 5000.42A).

**EVENT 9 RESOURCE SPONSOR.** The resource sponsor (CNO, OP-01, 29, or 39) selects an alternative from among those described in the TDAP or returns the TDAP for additional analysis. If the TDAP is approved, the resource sponsor tasks the DA, with a copy of the tasking to CNET, to develop the selected alternative and submit a Training Equipment Test and Evaluation Plan (TETEP) (Document 10.1) for approval. In the past when a selection was made, the resource sponsor would task CNET to prepare a Navy Decision Coordinating Paper (NDCP). The NDCP has recently been replaced by the TETEP, comparable to the Test and Evaluation Master Plan (TEMP), as the program initiation document for the acquisition process (OPNAVNOTE 5000, 9 June 1981).

**EVENT 10 DEVELOPMENT AGENT (DA).** The DA, usually NAVTRAEQUIPCEN, prepares the TETEP which responds to the resource sponsor decision among the alternatives presented in the TDAP (OPNAVINST 3960.10; NAVMATINST 3960.6A). The DA recommends to the resource sponsor, at the earliest possible date, the formation of a Fleet Project Team (FPT). The FPT, a group of knowledgeable representatives from the Fleet or other user activities, assists and advises the DA in the development, acquisition, and acceptance of the training device (OPNAVINST 1551.7B).

**DOCUMENT 10.1 TRAINING EQUIPMENT TEST AND EVALUATION PLAN (TETEP).** The TETEP is the proposed training community version of the TEMP. The TETEP includes the information formerly covered in the NDCP as well as test and evaluation plans, and replaces the NDCP as the program initiation document for the acquisition process. The TETEP and its two required appendices, the Training Equipment Functional Baseline (TEFB) and the Training Facilities Requirement (TFR), basically form a contractual agreement among the DA, the testing agents, the Naval Facilities Engineering Command, and the CNET. This relationship is approved by the resource sponsor.

The TETEP is a management guide for the comprehensive system of acquisition and test and evaluation throughout the RDT&E process. The TETEP subsumes the TDAP and defines objectives, procedures, required resources, and time schedule for Development Tests (DT) and Training Capability Tests (TCT) (OPNAVINST 3960.10). Occasionally, a Training Effectiveness Evaluation (TEE) is deemed essential by the CNET. The TEE is an optional evaluation for which requirements are also included in the TETEP when applicable. At present, no published criterion exists for deciding if a TEE is required, nor is there a format defining the nature of the TEE. The TETEP is revised annually since one of its major purposes is to report test and evaluation accomplished as well as planned. Each updated version includes more detailed test and evaluation plans which reflect the availability of more complete information.

The TEFB identifies the specific training objectives developed to meet the training requirements identified in the TOR and the technical specifications which were selected from among the alternatives in the TDAP to accomplish the training objectives. The TFR specifies the space, utilities, special facilities, and agreements between the DA and the involved commands required to support the training device. The TETEP also identifies the Training Capabilities Test Agent (TCTA) and the Training Effectiveness Evaluation Agent (TEEA) (if required), Events 14A and 14B.

**EVENT 11 CHIEF OF NAVAL EDUCATION AND TRAINING (CNET).** The Chief of Naval Education and Training, as training agent, specifies and approves the provisions in the TETEP which relate to training (NAVCOMPT Manual 075148). The DA forwards the TETEP to CNET (information copy to NAVMAT) who reviews the training objectives listed in the TEFB, the Operational Training Effectiveness portion of the TCT plan, and the TEE. The CNET recommends approval and forwards the TETEP to the resource sponsor.

**EVENT 12 RESOURCE SPONSOR.** When the resource sponsor approves the TETEP, it officially authorizes the program start. Approved TETEPs are sent to CNO (OP-098, Director, Research, Development, Test and Evaluation) for promulgation (Event 13) (OPNAVINST 5000.42A).

**EVENT 13 CNO (OP-098).** OP-098 acts for OPNAV as sponsor for the RDT&E appropriation and manages the planning and reporting procedures followed during the conduct of RDT&E. OP-098 also coordinates the formulation and promulgation of RDT&E requirements, appraises the progress of RDT&E effort, and, where appropriate, recommends projects for curtailment, suspension, or cancellation. Finally, OP-098, as the OPNAV focal point for TETEPs (OPNAVINST 5450.165) reviews TETEPs for adequacy of planned operational testing, including funding and scheduling (DODDIR 5000.3; OPNAVINST 5430.48). Promulgation of the TETEP and updated versions by OP-098 indicates acceptance of the RDT&E process to that point in the program and authorizes the continuation of development efforts.

**EVENT 14 DEVELOPMENT AGENT (DA).** The DA prepares Requests for Proposals (RFP) based on the TEFB and supporting documents, negotiates the contract(s), monitors and coordinates contractor development progress (Event 15), and conducts Development Tests (DTs) (Event 16) as specified in the TETEP (OPNAVINST 3960.10).

**EVENT 15 CONTRACT DEVELOPMENT:** This event represents that period of time required for preparation of contractual documents and the time required for the training device development and fabrication.

**EVENT 16 DEVELOPMENT TESTS (DT).** Development Tests are conducted throughout the different stages of the actual development of the prototype device by the DA in concert with the FPT (OPNAVINST 1551.7B). Development Tests demonstrate that the engineering design meets performance, reliability, maintainability, supportability, environmental compatibility, and system safety requirements as stated in the TEFB. Development Tests may include contractor tests and Navy acceptance tests. The final DT phase is normally on-site acceptance testing, the purpose of which is to certify that the device meets all technical requirements specified, is RFT, and is ready for training capability testing (DODDIR 5000.3; OPNAVINST 3960.10; NAVMATINST 3960.6A).

**EVENT 17 READY FOR TRAINING (RFT).** Ready for training certifies that the training device, installation, logistics support, training syllabus, lesson plans, and instructor training requirements as defined in the contract have been met and the device is ready for training (OPNAVINST 1551.7B; OPNAVINST 3960.10; NAVMATINST 3960.6A).

**EVENT 18 TRAINING CAPABILITY TEST (TCT).** Following certification as RFT, the device is submitted to a TCT by an independent agent. Independent agent is defined as a command or agency independent of the developing, procuring, and using commands. The TCT Agent (Event 14A) will perform the training capability tests which include Operational Suitability and Operational Training Effectiveness tests. Operational Suitability tests determine whether the device meets the requirements for reliability, maintainability, availability, logistic supportability, compatibility, interoperability, training, transportability, human factors, and safety in its intended environment as defined in the TEFB. Operational Training Effectiveness tests determine whether the device meets course objectives and stipulated course requirements as defined in the TEFB.

## Technical Report 118

**EVENT 19 APPROVAL FOR TRAINING ACCEPTANCE (ATA).** Devices which are certified RFT and which meet the requirements defined in the TEFB as determined by the TCTs are certified ATA. Once a device is certified ATA, follow-on devices may be procured for use throughout the training command. Deficiencies, identified during DTs (out of scope deficiencies) and TCTs, are corrected through a modification process or through procurement specifications. The modification process involves the awarding of modification contracts and Follow-on Test and Evaluation (FOTE) (OPNAVINST 4720.9D; NAVMATINST 4720.1).

**EVENT 20 TRAINING EFFECTIVENESS EVALUATION (TEE).** CNET may require a TEE. This decision must be made early in the acquisition cycle so that the DA may include planning and budgeting for the TEE in the TETEP. The TEE is performed by an independent agent (event 14B) who determines whether the device is effective in training students to satisfy the course objectives and in rare cases whether the training is transferrable to performance on the job (Management of Manpower, Personnel and Training Research, Development, Studies, and Surveys, CNO (OP-01) Draft June 1981; CNETINST 7000.2B).

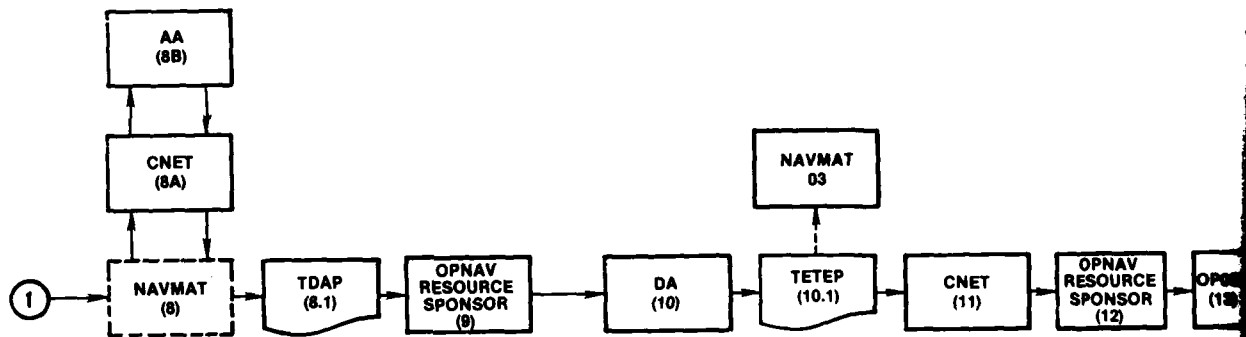
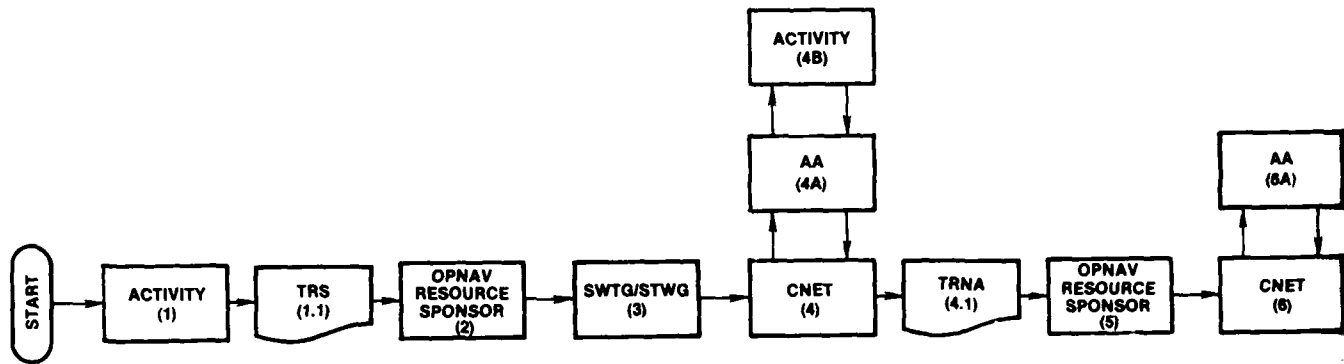

**LEGEND**

- |      |                                    |       |                             |
|------|------------------------------------|-------|-----------------------------|
| AA   | - ANALYSIS AGENT                   | TDAP  | - TRAINING CAPABILITY TESTS |
| ATA  | - APPROVAL FOR TRAINING ACCEPTANCE | TEE   | - TRAINING CAPABILITY TESTS |
| DA   | - DEVELOPMENT AGENT                | TEEA  | - TRAINING CAPABILITY TESTS |
| DT   | - DEVELOPMENT TESTS                | TETEP | - TRAINING CAPABILITY TESTS |
| RFT  | - READY FOR TRAINING               | TOR   | - TRAINING CAPABILITY TESTS |
| STWG | - SUBMARINE TRAINER WORK GROUP     | TRS   | - TRAINING CAPABILITY TESTS |
| SWTG | - SURFACE WAREFARE TRAINER GROUP   | TRNA  | - TRAINING CAPABILITY TESTS |
| TCT  | - TRAINING CAPABILITY TESTS        |       |                             |
| TCTA | - TRAINING CAPABILITY TESTS AGENT  |       |                             |

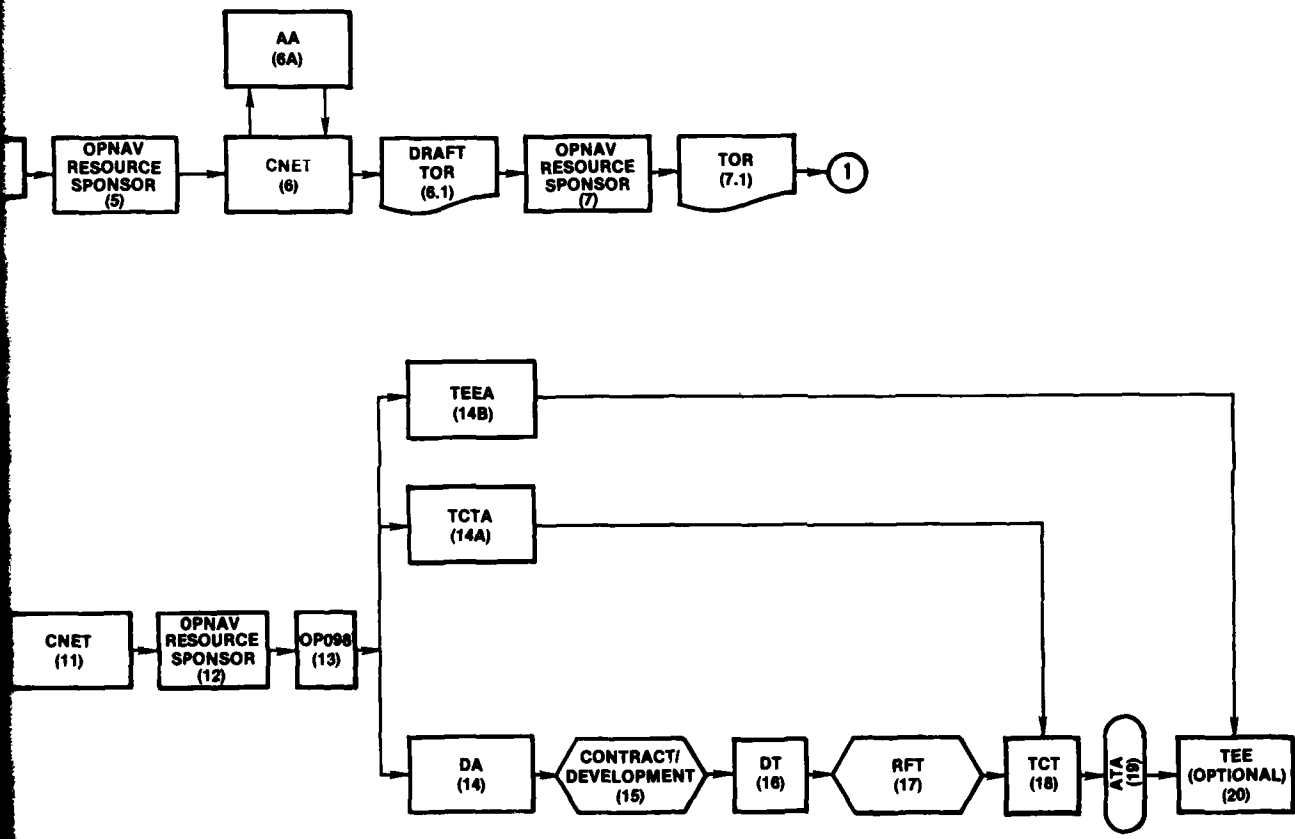

- ACCEPTANCE
- TDAP - TRAINING DECISION ALTERNATIVES PROPOSAL
  - TEE - TRAINING EFFECTIVENESS EVALUATION
  - TEEA - TRAINING EFFECTIVENESS EVALUATION AGENT
  - TETEP - TRAINING EQUIPMENT TEST AND EVALUATION PLAN
  - TOR - TRAINING OPERATIONAL REQUIREMENT
  - TRS - TRAINING REQUIREMENT STATEMENT
  - TRNA - TRAINING REQUIREMENT NEEDS ANALYSIS
- GROUP
- ER GROUP
- AGENT

Figure 9. RDT&E Events and Documentation Flow for First Article Training Devices

## SECTION IV

### STUDY TOPICS FOR CNET CONSIDERATION

During the development of the proposed Management System for RDT&E Training Device Acquisitions, major questions of command policy and procedures were raised. The directives governing these policies and procedures were used as the basis for proposed resolutions to these questions and for the resolution of conflicting opinions among commands. However, the policies and procedures proposed in this report still require the concurrence and/or approval of all concerned commands before a management system is implemented.

This section presents topics raised during the study that are of sufficient importance to warrant special consideration and concurrence of CNET. These topics could have far-reaching implications relevant to the role of CNET in RDT&E funded training device acquisitions and to the direction of future planned study efforts. Amplifying comments are provided where appropriate.

#### TOPIC NO. 1

Interpretation of relevant DOD and SECNAV directives supports the study premise that surface and subsurface first article training device acquisitions must follow the basic management principles and procedures established by DOD for RDT&E appropriated acquisitions.

The management process proposed in section III of this report is based on this premise; however, certain revisions to existing directives may be required to reflect suggested CNET management emphasis and control of training device requirement development and documentation. In addition, the terminology used in existing directives to describe major weapon system acquisitions will have to be converted to appropriate training system design terminology in pertinent CNET directives.

#### TOPIC NO. 2

The documents identified in section III will serve as the primary means for initiating and managing new surface and subsurface training device acquisition programs.

Ongoing TAEG efforts will continue in the development of the specific content of each of the required documents. These efforts will include close monitoring of any changes to the RDT&E process documentation requirements. The proposed format and content of each document will be forwarded to CNET when developed.

#### TOPIC NO. 3

CNET will be designated administering agent for surface/subsurface training device RDT&E funds.

## Technical Report 118

It is presumed that ongoing initiatives in this area will meet with an affirmative response. Designating CNET as administering agent for training device RDT&E funds should increase significantly the effectiveness of the proposed management system. However, even if an affirmative response is not received, sufficient authority exists in NAVCOMPT Manual 075148 and OPNAVINST 5450.194 for CNET to implement the proposed management system. Exercising this authority should improve CNET's capability for influencing prototype training device design which basically establishes the design for follow-on training devices.

### TOPIC NO. 4

A training device acquisition management guide, designed specifically for the training community, should be developed and used as the implementing vehicle for the proposed management system.

Ongoing TAEG efforts toward developing a management guide shall emphasize the relationship of RDT&E, training device acquisition, training system design, and the POM process. Other areas to be examined include developing a practical policy and procedures for training device T&E and describing specific organizational responsibilities for prototype and follow-on training device acquisitions.

### TOPIC NO. 5

The basic principles of training system design should be followed throughout the training requirement identification and training device acquisition processes.

Initiatives which would support adherence to training system design principles in training device acquisition include:

- sequence the conduct of training needs analyses in the following documents:
  - .. TRNA (identifies Terminal Objectives for training)
  - .. TETEP (identifies Enabling Objectives and evaluation procedures for Terminal and Enabling Objectives)
- design TRS, TRNA, TDAP, and TETEP documents to require the conduct of thorough training analyses.

### TOPIC NO. 6

Training device requirements should be identified and training system design budget requirements should be submitted at the earliest possible date in major weapon system and equipment acquisition cycles.

CNET should develop with NAVSEASYSKOM procedures for the earliest possible identification of training device requirements for major weapon system and equipment acquisition projects and for the earliest possible submission of training system design budget requirements. An existing NAVMAT directive already mandates this action (NAVMATINST 1500.12).

## Technical Report 118

### TOPIC NO. 7

RDT&E funded first article training device acquisition programs will include technical and fiscal provisions for T&E in accordance with the basic T&E requirements set forth in DOD and OPNAV policy directives.

Although training device T&E programs are ongoing within the CNET, there is at this time no official CNET directive which establishes policy or procedures for training device T&E. TAEG should assume, as part of the management guide development tasking, the responsibility to develop guidelines which establish policy and procedures for training device T&E. Particular emphasis should be devoted to the development of (1) criteria for determining when CNET sponsored T&Es are required and (2) practical cost-effective procedures for conducting T&Es without undue interruption or delay to ongoing training.

### TOPIC NO. 8

The proposed training device acquisition management system must be capable of rapidly responding and adapting to changes in the DOD acquisition process and to changes in organizational structures, responsibilities, and procedures.

There are, at the time of this writing, various ongoing unresolved initiatives involving the CNET, CHNAVMAT, SYSCOMs, and NAVTRAEQUIPCEN which potentially could result in the revision of training device acquisition management policy. These initiatives will be closely monitored during TAEG development of implementation means and procedures for the proposed training device acquisition management system. The TAEG should design a management system guide with sufficient flexibility that it can be easily adapted to subsequent changes in the RDT&E process or in the responsibilities or procedures of organizations involved in RDT&E funded training device acquisitions.

Technical Report 118

ANNEX A  
GLOSSARY

**GLOSSARY**

**ACCEPTANCE FOR SERVICE USE:** The determination made by the SECNAV to accept or reject a ship or aircraft model based on the results of an acceptance trial conducted by the Board of Inspection and Survey. (OPNAV 4720.9)

**ACQUISITION:** The process consisting of planning, designing, producing, and distributing a weapon system/equipment. Acquisition in this sense includes the conceptual, validation, full-scale development, production, and deployment/-operational phases of the weapon systems/equipment project. For those weapon systems/equipments not being procured by a project manager, it encompasses the entire process from inception of the requirement through the operational phase. (NAVMAT 4000.20)

**ACQUISITION CATEGORY (ACAT):** One of four acquisition categories established by CNO which govern acquisition procedures and responsibilities and assign respective decision authority levels. (OPNAV 5000.42)

**ACQUISITION MANAGER (AM):** An individual charged with overall responsibility for acquisition of weapons systems, individual items of equipment, and facilities as well as planning for logistic support of these end items. Examples of individuals regarded as Acquisition Managers are: Project Managers, system project engineers, and component project engineers. (NAVMAT 4000.20)

**ANALYSIS:** The qualitative and/or quantified evaluation of information requiring technical knowledge and judgment. (DOD 5100.45)

**APPROVAL FOR SERVICE USE (ASU):** That determination made by the Chief of Naval Operations, or other delegated authority, that new systems/equipments or significant alterations to existing systems/equipments have undergone appropriate test and evaluation to the extent there has been:

1. Demonstrated reliable performance in accordance with design specification in the intended or existing operational environment.
2. Demonstrated ability to be operated and maintained by personnel with the level of skill anticipated to be available under Navy service conditions.
3. Sufficient evidence that the equipment can be supported logistically in a deployed status. (OPNAV 4720.9)

**APPROVAL FOR SERVICE USE, PROVISIONAL:** That determination made by the Chief of Naval Operations, or other delegated authority, that new systems or equipments, or significant alterations to existing equipments, have undergone early phases of appropriate test and evaluation, to the extent that:

1. Reliable performance, in accordance with design specifications, in the intended or existing operational environment is indicated.
2. Ability to be operated or maintained by personnel with the level of skill anticipated to be available under Navy service conditions is indicated.

## Technical Report 118

3. Logistic support in a deployed status is assessed as feasible. (OPNAV 4720.9)

**AVERAGE AWAITING INSTRUCTION:** Sum of the number of students awaiting instruction (entry into a class) each calendar day (including weekends and holidays) of a month divided by the total number of calendar days in that month. Awaiting instruction includes students arriving prior to class convening date and students in excess of available seats on convening date (backlogged). Awaiting students assigned to mess-cooking, compartment cleaning, or other service work should be included in the count. Normally computed for each individual course. Average awaiting instruction for a training activity is the sum of the averages awaiting instruction for each of the individual courses conducted at the training activity.

$$\text{Average awaiting instruction} = \frac{\text{Sum of student count awaiting instruction each calendar day of the month}}{\text{Number of calendar days in the month}}$$

**AVERAGE UNDER INSTRUCTION:** Sum of the number of students under instruction each calendar day (including weekends and holidays) of a month divided by the total number of calendar days in the month. Normally computed for each individual course. Average under instruction for a training activity is the sum of the averages under instruction for each of the individual courses.

**BASELINE DATA:** Valid and reliable information about the current level of performance of the intended student population. This data can be used to confirm the need to develop new instruction, or can be used as a comparison in ascertaining differences between students' performance before and after instruction.

**BASIC RESEARCH:** Research which is directed toward increase in knowledge of science. It is research where the primary aim of the investigator is a fuller understanding of the subject under study (DOD 3210.1)

**BENEFIT-COST ANALYSIS:** An analytical approach to solving problems of choice. It requires the definition of objectives, identification of alternative ways of achieving each objective, and the identification, for each objective, of that alternative which yields the required level of benefits at the lowest cost. This same analytical process is often referred to as cost-effectiveness analysis when the benefits or outputs of the alternatives cannot be quantified in terms of dollars. (DOD 7041.3)

**BREADBOARD:** An assembly of preliminary circuits or parts used to prove the feasibility of a device, circuit, system or principle without regard to the final configuration or packaging of the parts. (Van Nostrand's Scientific Encyclopedia, Fifth Edition, 1976)

**CHART, FLOW:** A graphic presentation using symbols to show the step-by-step sequence of operations or procedures. (DOD 5000.8)

**CHOP:** Expression indicating concurrence. (Navy Programming Manual)

## Technical Report 118

**CONTRACT:** An agreement, enforceable by law, between two or more competent parties, to do or not to do something not prohibited by law, for a legal consideration. (DOD 5000.8)

**COST ANALYSIS:** An analytical process employed to predict the resource requirements for weapon systems and programs. (SECNAV 7000.19)

**COST/EFFECTIVENESS ANALYSIS:** A method for examining alternative means of accomplishing a desired military objective/mission for the purpose of selecting weapons and forces which will provide the greatest military effectiveness for the cost. (Navy Programming Manual)

**CURRICULUM:** The planned interaction of students with instructional resources, and instructional processes for the attainment of learning objectives.

**CURRICULUM OUTLINE:** The control document for a course expressed in outline form listing Units/Modules and Lesson Topics in their sequential order with the learning objectives which they support.

**DECISION COORDINATING PAPER (DCP):** The principal document to record essential system program information for use in support of the SECDEF decision-making process at Milestones I, II, and III. (DOD 5000.1)

**DEVELOPING AGENCY (DA):** The Systems Command or CNM-designated project manager assigned responsibility for the development, test and evaluation of the weapon system, subsystem or item of equipment. (OPNAV 3960.10)

**DEVELOPMENT PROPOSAL (DP):** Prepared by the NMC or Bureaus in response to an OR, the DP presents a range of alternatives and tradeoffs to achieve a particular range of capabilities. (OPNAV 5000.42)

**DEVELOPMENT TESTS:** DTs are conducted throughout the different stages of actual development of the prototype device by the Developing Agent (DA) in concert with the Fleet Project Team (FPT). DTs demonstrate that the engineering design meets performance, reliability, maintainability, supportability, environmental compatibility, and system safety requirements as stated in the Training Equipment Functional Baseline (TEFB) document. Satisfactory performance results in certification of the device Ready for Training (RFT).

**DIRECTIVE:** Includes Navy Instructions, Supplements, Change Transmittals, and Notices, as well as DOD Directives, Instructions and Transmittals. (NAVMAT 5215.4)

**DOCUMENT:** Any recorded information or data regardless of physical form or characteristics, including but not limited to the following:

1. Written or printed material: (whether handwritten, printed or typed);
2. Data processing cards or tapes;

## Technical Report 118

3. Maps, charts, photographs, negatives, moving or still films, or film strips;
4. Paintings, drawings, engravings, or sketches;
5. Sound or voice recordings;
6. Reproductions of the foregoing by any means or process.  
(DOD5200.38)

**EFFECTIVENESS:** The performance or output received from an approach or a program. Ideally, it is a quantitative measure which can be used to evaluate the level of performance in relation to some standard, set of criteria, or end objective. (SECNAV 7000.14)

**ENABLING OBJECTIVE:** A statement of a subordinate or lower level behavior or performance which enables the student to perform a learning objective, expressed in terms of the behavior, the conditions under which it is to be exhibited, and the standards to which it will be performed or demonstrated. It should be noted that some enabling objectives may be eliminated by including them in the course prerequisite skills. Example: given the diameter of a circle and a pencil and paper or handheld calculator, compute the circumference of the circle and display it in the same units as those used to express the diameter. (This could be an enabling objective for a learning objective which requires the student to determine the wear in a cylinder, given the previous diameter and a pair of inside calipers, the wear to be expressed to the nearest thousands of an inch. The same result may be achieved by making the science of plane geometry a course prerequisite.)

**EVALUATION, OPERATIONAL:** The test and analysis of a specific end item or system, insofar as practicable under service operating conditions, in order to determine if quantity production is warranted considering (1) the increase in military effectiveness to be gained and (2) its effectiveness as compared with currently available items or systems, consideration being given to: (a) personnel capabilities to maintain and operate the equipment, (b) size, (c) enemy capabilities in the field. (Navy Programming Manual)

**EVALUATION, TECHNICAL:** The study and investigation by a developing agency to determine the technical suitability of material, equipment, or a system, for use in the Military Services. (Navy Programming Manual)

**FOLLOW-ON OPERATIONAL TEST AND EVALUATION (FOT&E):** All OT&E after the first major production decision. (OPNAV 3960.10)

**INITIAL OPERATIONAL TEST AND EVALUATION (IOT&E):** All OT&E prior to the first major production decision. (OPNAV 3960.10)

**INTEGRATED LOGISTIC SUPPORT:** A composite of all the support considerations necessary to assure the effective and economical support of a system for its life cycle. It is an integral part of all other aspects of system acquisition and operation. Integrated logistic support is characterized by harmony and coherence among all the logistic elements. (DOD 4100.35)

## Technical Report 118

**INVENTION:** Any art, machine, manufacture, design, or composition of matter, or any new and useful improvement thereof, or any variety of plant, which is or may be patentable under the patent laws of the United States. (SECNAV 5870.3)

**LEAD COMPONENT:** The DOD Component designated by the SECDEF to be responsible for management of a system acquisition involving two or more Components in a joint program. (DOD 5000.1)

**LEAD-TIME, PROCUREMENT:** The time interval between the initiation of procurement action and the receipt into the supply system of material purchased as a result of such action. (DOD 5000.8)

**LEAD-TIME PRODUCTION:** The time interval between the placement of a contract and receipt into the supply system of material acquired. (DOD 5000.8)

**LEARNING OBJECTIVE:** A statement of the behavior or performance expected of a student as the result of a learning experience, expressed in terms of the behavior, the conditions under which it is to be exhibited, and the standards to which it will be performed or demonstrated. Example: given a pencil and paper, and without access to any outside resources of assistance, the student will list the names of all the 50 states of the United States.

**LIFE CYCLE COST:** The sum total of the direct, indirect, recurring, nonrecurring, and other related costs incurred, or estimated to be incurred, in the design, development, production, operation, maintenance and support of a major system over its anticipated useful life span. (OMB Cir. A-109)

**LIFE CYCLE COST:** The total cost to the Government for the development, acquisition, operation and logistic support of a system or set of forces over a defined life span. (Navy Programming Manual)

**LIFE CYCLE COSTING:** Life Cycle Costing (LCC) is an acquisition or procurement technique which considers operating, maintenance, and other costs of ownership as well as acquisition price in the award of contracts for hardware and related support. (NAVMAT 4000.20)

**LIMITED PRODUCTION:** The initial low-rate production of a system in limited quantity to be used in operational test and evaluation for verification of production engineering and design maturity and to establish a production base prior to a decision to proceed with production. (DOD 5000.1)

**LONG LEAD ITEMS:** Those components of a system or piece of equipment for which the times to design and fabricate are the longest and, therefore, to which an early commitment of funds may be desirable in order to meet the earliest possible date of system completion. (DODDIR 5000.3)

**MAINTAINABILITY:** A characteristic of design and installation which is expressed as the probability that an item will be retained in or restored to a specified condition within a given period of time, when the maintenance is performed in accordance with prescribed procedures and resources. (NAVMAT 4000.20)

## Technical Report 118

**MAINTENANCE ENGINEERING:** That activity of equipment maintenance which develops concepts, criteria and technical requirements during the conceptual and acquisition phases to be applied and maintained in a current status during the operational phase to assure timely, adequate and economic maintenance support of weapons and equipments. (DOD 4151.12)

**MAJOR:** Programs designated by the Secretary of Defense as major system acquisition programs. The designation shall be determined on the recommendations of the DOD Component Head and Office of the Secretary of Defense (OSD) officials. System Programs involving an anticipated cost of \$75 million in research, development, test and evaluation (RDT&E) or \$300 million in production shall be considered for designation as major system acquisitions. (DODINST 5000.1)

**MANAGEMENT AND SUPPORT:** Includes research and development effort directed toward support of installations or operations required for general research and development use. (DOD 7720.16)

**MANAGEMENT CONTROL:** The entire system of organization, policies, procedures, and practices employed in managing an agency's affairs and promoting the carrying out of assigned responsibilities effectively, in the manner and with the results intended. (SECNAV 5741.6)

**MANAGEMENT SYSTEM:** A documented method for assisting managers in defining or stating policy, objectives or requirements; assigning responsibility; controlling utilization of resources; periodically measuring performance; comparing that performance against stated objectives and requirements; and taking appropriate action. (DOD 7000.6)

**MISSION AREA:** A major subdivision of a mission, so extracted that it generally parallels the traditional naval warfare and support areas. (OPNAV 3501.2)

**MISSION AREA:** A segment of the Defense mission as established by the SECDEF. (DOD 5000.1)

**MISSION ELEMENT:** A segment of a mission area critical to the accomplishment of the mission area objectives and corresponding to a recommendation for a major system capability as determined by a DOD Component. (DOD 5000.1)

**MISSION ELEMENT NEED STATEMENT (MENS):** A statement prepared by a DOD Component to identify and support the need for a new or improved mission capability. The mission need may be the result of a projected deficiency or obsolescence in existing systems, a technological opportunity, or an opportunity to reduce operating cost. The MENS is submitted to the SECDEF for a Milestone I decision. (DOD 5000.1)

**MISSION NEED:** A required capability within an agency's overall purpose, including cost and schedule considerations. (OMB Cir. A-109)

## Technical Report 118

**MISSION SPONSOR:** The CMC, a DCNO or a Director of a major staff office who is designated as responsible for determining objectives, time phasing and support requirements and for appraising readiness and capability to fulfill the assigned mission. (Navy Programming Manual)

**NAVY DECISION COORDINATING PAPER (NDCP):** Documents which support and promulgate CNO decisions to initiate conceptual development programs and establish appropriate Advanced/Engineering Development budget line items. They serve as the basis for preparing Decision Coordinating Papers (DCP) and are prepared in the DCP format. (OPNAV 5000.42)

**NAVY TRAINING PLAN (NTP):** The principal document for stating billets, personnel, military construction, and training material support requirements. It controls the planning and implementing action for meeting the requirements of the system sub-system components or nonhardware-oriented development, to produce trained and qualified personnel required to install, operate, maintain, or otherwise use the same being introduced into the Navy.

**NAVY TRAINING PLAN CONFERENCE:** The principal training planning conference formally or informally scheduled for the purpose of developing and documenting personnel and training support requirements for new or modified systems or developments introduced into the Navy. The degree of participation and formality depends on the magnitude of the new development or extent of modification.

**OBJECTIVE:** A goal, expressed as that portion of the "what," "when," and "where" of a requirement which is reasonably feasible of attainment within the expected availability of the resources of men, money, and technological capability. (Navy Programming Manual)

**OBLIGATION:** The amount of an order placed, contract awarded, service received, or other transaction which legally reserves a specified amount of an appropriation or fund for expenditure. (Navy Programming Manual)

**OPERABILITY:** The design characteristic of the system/equipment that will assure personnel feasibility and optimum utilization of operator personnel. (NAVMAT 4000.20)

**OPERATIONAL CAPABILITY:** A subdivision of a mission area which more specifically delineates appropriate operational functions. (OPNAV 3501.2)

**OPERATIONAL CONTROL:** The exercise of executive authority and responsibility for the performance of mission tasks assigned, including the responsibility for assuring appropriate coordination and application of technical guidance. (DOD 5100.38)

**OPERATIONAL EFFECTIVENESS:** The overall degree of mission accomplishment of a system used by representative troops in the context of the organization, doctrine, tactics, threat, and environment in the planned operational employment of the system. (DOD 5000.3)

**OPERATIONAL REQUIREMENT (OR):** The basic requirement document for all Navy acquisition programs requiring research and development effort. The OR solicits Development Proposals (DPs) from the Naval Material Command or Bureaus, as appropriate. (OPNAV 5000.42)

## Technical Report 118

**OPERATIONAL SUITABILITY:** The determination made by COMOPTEVFOR prior to the major production decision. It involves quantitative and qualitative assessments of the following design attributes: reliability, maintainability, supportability, operability, and compatibility and interoperability with other systems as well as training and logistic requirements. (DOD 5000.3)

**OPERATIONAL SYSTEMS DEVELOPMENT:** Includes research and development effort directed toward development, engineering and test of systems, support programs, vehicles and weapons that have been approved for production and service deployment. (DOD 7720.16)

**OPERATIONAL TEST AND EVALUATION (OT&E):** That test and evaluation conducted to estimate the prospective systems' military utility, operational effectiveness, and operational suitability (including compatibility, interoperability, reliability, maintainability, and logistic and training requirements), and need for any modifications. In addition, OT&E provides information on organization, personnel requirements, doctrine and tactics. Also, it may provide data to support or verify material in operating instructions, publications, and handbooks. (OPNAV 3960.10 Encl 1)

**PILOT PRODUCTION:** The controlled manufacture of limited numbers of an item for service test and evaluation purposes using manufacturing drawings and specifications which have been developed for quantity production and with tooling that is representative of that to be used in unlimited production. (NAVAIR 4200.12)

**PILOT PRODUCTION ITEM:** An item that is produced from a limited production run of a new system which has completed engineering development and for which the capability to mass produce the item needs to be demonstrated. (DODDIR 5000.3)

**PLANNING ESTIMATE (PE):** The estimates of operational/technical characteristics, schedule and program acquisition cost for both development and procurement when approval is given by the Secretary of Defense for program initiation. (DOD 7000.3)

**PLANNING/PROGRAMMING/BUDGETING SYSTEM (PPBS):** An integrated system for the establishment of the FYDP and the DOD budget. (DOD 7045.7)

**PRE-PRODUCTION PROTOTYPE:** An article in final form employing standard parts, representative of articles to be produced subsequently in a production line. (DODDIR 5000.3)

**PRINCIPAL DEVELOPMENT ACTIVITY (PDA):** The agency assigned by the Chief of Naval Material to undertake the management and technical responsibility for prosecution of the development effort, including timely budgeting for the allocation of resources within the approved plan. (NAVMAT 5000.22)

**PROCUREMENT:** Includes purchasing, renting, leasing, or otherwise obtaining supplies or services. It also includes all functions that pertain to the obtaining of supplies and services, including description but not determination of requirements, selection and solicitation of sources, preparation and award of contracts, and all phases of contract administration. (DOD 5126.34)

## Technical Report 118

**PRODUCIBILITY:** The degree to which articles can be replicated, given the considerations of manufacturing techniques, availability of materials and labor, and total costs. (DODDIR 5000.3)

**PRODUCTION ACCEPTANCE TEST AND EVALUATION (PAT&E):** Test and evaluation of production items to demonstrate that the items procured fulfill the requirements and specifications of the procuring contract or agreements. (OPNAV 3960.10)

**PROGRAM:** An organized set of activities directed toward a common purpose, objective, or goal undertaken or proposed by an agency in order to carry out responsibilities assigned to it. (OMB Cir. A-109)

**PROGRAM:** A plan or scheme of action designed for the accomplishment of a definite objective which is specific as to the time-phasing of the work to be done and the means proposed for its accomplishment, particularly in quantitative terms, with respect to manpower, material, and facilities requirements. (DOD 5000.8)

**PROGRAM:** A combination of program elements designed to express the accomplishment of a definite objective or plan which is specified as to the time-phasing of what is to be done and the means proposed for its accomplishment. Programs are aggregations of program elements and in turn aggregate to the total Five-Year Defense Program. (DOD 7045.7)

**PROGRAM CHANGE REQUEST (PCR):** Proposals, in prescribed format, for changes to the approved data in the Five-Year Defense Program. (DOD 7045.7)

**PROGRAM COORDINATOR:** The individual within OPNAV who is responsible to a Program Sponsor for the formulation and administration of a program. (Navy Programming Manual)

**PROGRAM INITIATION DECISION:** The Milestone 0 decision, based on an approved mission need, by which the SECDEF directs one or more Components to systematically and progressively explore and develop alternative concepts to satisfy the approved mission need. (DOD 5000.1)

**PROGRAM MANAGER:** The individual in the DOD chartered to manage a major system acquisition program. (DOD 5000.1) (See Project Manager)

**PROGRAM OBJECTIVE MEMORANDUM (POM):** A memorandum in prescribed format submitted to the SECDEF by the Secretary of a Military Department or the Director of a Defense Agency which recommends the total resource requirements within the parameters of the published Secretary of Defense fiscal guidance. (DOD 7045.7)

**PROGRAM OBJECTIVES:** The capability, cost and schedule goals being sought by the system acquisition program in response to a mission need. (OMB Cir. A-109)

**PROGRAM SPONSOR:** The DCNO or Director of a Major Staff Office who, by organization charter, is responsible for determining program objectives, time-phasing and support requirements, and for appraising progress, readiness, and military worth for a given weapon system, function or task. (Navy Programming Manual)

## Technical Report 118

**PROGRAM YEAR:** A fiscal year in the Five-Year Defense Program that ends not earlier than the second year beyond the current calendar year. Thus, during calendar year 1971, the first program year was FY 1973. (Navy Programming Manual)

**PROGRAMMING:** The process of preparing a program, especially in terms of quantitative, physical requirements of manpower, material, and facilities. (DOD 5000.8)

**PROGRAMMING BUDGETING SYSTEM:** The procedures for the establishment, maintenance and revision of the Five-Year Defense Program and the DOD budget. (DOD 7045.7)

**PROJECT:** A planned undertaking having a finite beginning and ending, involving definition, development, production, and logistic support of a major weapon or weapon support system or systems. A project may be a whole or a part of a program. Within the NMC, a Designated Project is a project which, because of its importance or critical nature, has been selected for intensified project management. (Navy Programming Manual)

**PROJECT MANAGEMENT:** Management of a project, using organizational or procedural alignments, which will permit varying degrees of intensified direction. This may apply to management of a complete system or any portion thereof, and it may include all phases of development, production, and distribution, or be limited to a single phase; e.g., development. (Navy Programming Manual)

**PROJECT MANAGER (PM):** The single individual responsible for a particular weapon system acquisition project. The Project Manager is the representative of the Developing Agency and derives his authority from a charter issued by such agency. (OPNAV 5000.42)

**PROJECT MANAGER (PM):** The individual within the NMC, Bureaus, and Offices responsible, within well-defined boundaries of time, resources, and performance requirements, for executing an approved project. (Navy Programming Manual)

**PROJECT MASTER PLAN (PMP):** The document, developed and issued by the Project Manager/Acquisition Manager, which shows the integrated time-phased tasks and resources required to complete the objectives specified in the requirements document. (NAVMAT 5200.11)

**PROJECT ORDER:** A specific, definite and certain order issued under the Authority contained in 41 U.S.C. 23 for the manufacture of materials, supplies and equipment, or for other work or services which, when placed with and accepted by a separately managed and financed Government-owned and operated establishment, serves to obligate appropriations in the same manner as orders or contracts placed with commercial enterprises. (DOD 7220.1)

**RDT&E PROGRAM:** Consists of all efforts funded from the RDT&E appropriation regardless of program category or program element. (DOD 7720.13)

## Technical Report 118

**READY FOR TRAINING:** A device is certified RFT when it meets all technical requirements specified in the Development Test (DT) portion of the Training Equipment Test and Evaluation Plan. RFT certification includes the training device, installation, logistic support, training syllabus, lesson plans, and instructor training as defined in the contract. Finally, RFT means the device is ready for Training Capability Tests (TCT).

**RELIABILITY:** The probability that an item will perform its intended functions for a specified period of time under stated conditions. (NAVMAT 4000.20)

**RELIABILITY, ACHIEVED:** A statistical estimate of reliability based on actual demonstrations under specified conditions. (SECNAV 3900.36)

**RESEARCH:** Attempts to examine natural phenomena categorized in the normal scientific disciplines (physical, engineering, environmental, biomedical, behavioral and social sciences) to obtain better, more comprehensive knowledge. (DOD 5100.62)

**RESEARCH:** Defense research is scientific study and experimentation directed toward increasing knowledge and understanding in those fields of the physical, engineering, environmental, biological-medical, and behavioral sciences directly related to explicitly stated long-term national security needs. It provides fundamental knowledge for the solution of identified military problems. It also provides part of the base for subsequent exploratory and advanced developments in Defense-related technologies and of new or improved military functional capabilities in areas such as communications, detection, tracking, surveillance, propulsion, mobility, guidance and control, navigation, energy conversion, materials and structures, and personnel support. (DOD 3210.1)

**SCHOOL:** An organizational entity encompassing students, instructors, support staff, facilities, equipment and other resources required for conducting instruction in a specified area of specialization. A school may be a separate activity with a commanding officer or officer-in-charge or other officer in authority, but often is a component division, department or other organizational entity of a schools command or other education or training activity.

**SCIENCE AND TECHNICAL INFORMATION:** Includes documentary, information, and reference products or services in the form of technical information either generated by or gathered for the research, development, test, and evaluation programs of the Department of Defense. The related bibliographies, indexes, announcements and state-of-the-art studies are also included. (DOD 5200.21)

**SELF-INSTRUCTIONAL TRAINER:** A trainer which can be used without immediate or continuous supervision by an instructor. It contains programmed instructions to guide the trainees and provides means for correcting and directing the student when errors are made. It may also include provisions for automatically scoring and recording the trainee's performance.

## Technical Report 118

**SHIPBORNE SYSTEM:** A Shipborne System is an integration of parts, assemblies, sets, and systems (as defined in MIL-STD-280) joined together to perform a specific operational function or functions, and performing part of or operating from a ship. This is a generic term intended to include in its meaning any of the various major or minor systems in a ship; for example, Ordnance System, Aircraft Support System, Propulsion System, Communications System. (NAVMAT 5400.14)

**SIMULATION:** Any change from reality or any imitation of reality. Three types are common: simulating part of the system, simulating the operation of the system, and simulating the environment in which the system will operate.

**SIMULATOR:** A training device which substitutes for but emulates the functions and environment of actual equipments or systems.

**SKILL:** The ability to perform a job-related activity which contributes to the effective performance of a task.

**SPECIFICATION:** A document intended primarily for use in procurement, which clearly and accurately describes the essential technical requirements by which it will be determined that the requirements have been met. Specifications for items and materials may also contain preservation, packaging, packing and marking requirements. (DOD 4120.3)

**STANDARD:** An established or accepted rule, measure, or model by which the degree of satisfactoriness of a product or act is determined. (DOD 5000.8)

**STANDARD:** A document that establishes engineering and technical limitations and applications for items, materials, processes, methods, designs, and engineering practices. (DOD 4120.3-M)

**STIMULATOR:** A training device designed for interconnection with operational equipment, and which will create synthetically in the operational equipment, conditions that replicate to some degree those created in the operational environment. All, or only portions, of an operational system may be stimulated dependent on training needs and technical trade-offs to achieve the desired training capability.

**STUDIES AND ANALYSES:** Critical examination and investigation of a subject, often requiring sophisticated analytical techniques to integrate a variety of factors, leading to conclusions or recommendations making substantive contributions to planning, programming and decision making. Unlike experimentally-oriented research and development activities, studies and analyses are typically "pencil and paper" efforts (often computer-assisted) which usually do not generate new scientific knowledge per se. Studies are designed to organize and evaluate data and information already available (or which can be inferred or extrapolated from existing data) to provide greater understanding of relevant alternative policies, systems or programs. (DOD 5100.62)

**SUBMARINE TRAINER WORK GROUP:** The STWG ensures timely identification of training device needs, provides overall direction regarding planning for submarine training devices, and establishes the Fleet Project Team (FPT).

## Technical Report 118

**SUPPORT TECHNOLOGY:** Exploratory Development which is not exclusively associated with any one of the other functional areas (NAVMAT 3910.12)

**SURFACE WARFARE TRAINER GROUP:** The SWTG ensures timely identification of training device needs, participates in the analysis and prioritization of Training Requirement Statements (TRS), the development of Training Operational Requirements (TOR), and Training Decision Analysis Papers (TDAP). The SWTG recommends members to the Fleet Project Team and monitors RDT&E progress in the development of training devices.

**SURVIVABILITY:** The degree to which a system is able to avoid or withstand a man-made hostile environment without suffering an abortive impairment of its ability to accomplish its designated mission. (DOD 5000.3)

**SYSTEM:** An assembly of procedures, processes, methods, routines or techniques united by some form of regulated interaction to form an organized whole. (Navy Programming Manual)

**SYSTEM ACQUISITION PROCESS:** A sequence of specified decision events and phases of activity directed to achievement of established program objectives in the acquisition of Defense systems and extending from approval of a mission need through successful deployment of the Defense system or termination of the program. (DOD 5000.1)

**SYSTEMS ANALYSIS:** Tracing out some of the consequences of alternative weapons or actions and exhibiting these consequences to decision makers. (Navy Programming Manual)

**SYSTEM DESIGN CONCEPT:** An idea expressed in terms of general performance, capabilities, and characteristics of hardware and software oriented either to operate or to be operated as an integrated whole in meeting a mission need. (OMB Cir. A-109)

**SYSTEM ENGINEERING, DEFENSE:** That portion of the acquisition process dealing with the transformation of an operational need into an optimal set of system performance parameters and a preferred system configuration. It includes engineering/technical management, definition of system and program, design engineering, support engineering, the integration of the engineering specialties, and other such factors that affect the development, production, deployment, operation, and disposal of the system.

**SYSTEM ENGINEERING PROCESS:** A logical sequence of activities and decisions transforming an operational need into a description of system performance parameters and a preferred system configuration.

**SYSTEMATIC:** Refers to the methodical performance of a task. The task is accomplished with a thoroughness and regularity that may be attributed at least in part to the proceduralized treatment.

**SYSTEMIC:** Refers to the application of a system; the application of a coherent body of ideas and principles to the solution of a problem.

## Technical Report 118

**TEAM TRAINER:** An operator trainer which takes personnel trained and qualified in their individual skill specialties and trains them together to perform as a team (e.g., an aircraft weapon system trainer).

**TECHNICAL DATA:** Recorded information, regardless of form or characteristic, of a scientific or technical nature. It may, for example, document research, experimental, developmental or engineering work; or be usable or used to define a design or process or to procure, produce, support, maintain, or operate material. The data may be graphic or pictorial delineations in media such as drawings or photographs, in test specifications, related performance or design-type documents; in machine forms such as punched cards, magnetic tape, computer memory printouts; or may be retained in computer memory. (NAVMAT 4000.15)

**TECHNICAL EVALUATION:** The final subphase of Development, Test and Evaluation (DT&E), the purpose of which is to certify that the design meets specified requirements and is ready for Operational Evaluation (OPEVAL). (OPNAV 3960.10)

**TECHNICAL INFORMATION:** Information or data, including scientific information, which relate to research, development, engineering, test, evaluation, production, operation, use, or maintenance of munitions and other military supplies and equipment. (DOD 5200.20)

**TECHNICAL REPORT:** Any document written for the permanent record to document results obtained from, and recommendations made on, scientific and technical activities relating to a single project, task, or contract, or relating to a small group of closely related efforts. (DOD 5100.38)

**TECHNICAL SERVICES:** Those services associated with the installation, operation and maintenance of aircraft and shipboard weapons, equipment and systems and performed by in-house and contract personnel qualified and trained in engineering and technical disciplines. (NAVMAT 4350.12)

**TECHNOLOGICAL LIFE:** The estimated number of years before technology will make the existing or proposed equipment or facilities obsolete. (OPNAV 7000.18)

**TECHNOLOGY:** Includes all effort directed toward eliminating major technical barriers and providing unique solutions to significant technical problems encountered in RDT&E programs. (DOD 7020.13)

**TERMINAL OBJECTIVE:** A statement of the behavior or performance of a student in the achievement of a task after he has arrived on the job, under the conditions and to the standards required by the job. It differs from a Learning Objective in that it relates to the required performance on the job, whereas the latter relates to the required performance in the learning environment. Example: Under the general supervision of the petty officer of the watch, light off the distilling plant in accordance with the procedures set forth in Ship's Engineering Order No. 17. Because the schoolhouse may not have a suitable distilling plant on which the student may demonstrate the above skill, the Learning Objective corresponding to the Terminal Objective might state that the student, given pencil and paper and without access to outside assistance, will list the 13 steps in the lighting off of a distilling plant as set forth in NAVMAT Manual 16-74.

Technical Report 118

**TEST AND EVALUATION MASTER PLAN:** An overall test and evaluation plan, prepared as early as possible in the acquisition process, and designed to identify and integrate objectives, responsibilities, resources, and schedules for all test and evaluation to be accomplished prior to the subsequent key decision points. (DODDIR 5000.3)

**TEST CRITERIA:** Standards by which test results and outcome are judged. (DODDIR 5000.3)

**THREAT:** The capability of a potential enemy to limit or negate mission accomplishment or to neutralize or reduce the effectiveness of a current or projected Navy force, system, or item of material. (OPNAV 3811.1)

**THREAT STATEMENT:** A statement of the threat expressed in necessary detail in the context of a specific problem or project to support Navy planning and development of concepts, doctrine or material. (OPNAV 3811.1)

**THRESHOLDS:** Monetary, time, or resource limitations placed on a program, to be used as guides as the program progresses and the breaching of which is cause for careful review of at least some aspects of the program. (DODDIR 5000.3)

**TRAINER:** Manipulative aids or devices used in the development and transfer of skills instruction to performance on the job. Used interchangeably with the term "Training Device."

**TRAINING:** The acquisition of skills directed to specific tasks and usually predicated on the prior acquisition of knowledge.

**TRAINING AGENCY:** An office, bureau, command, or headquarters exercising command of and providing support to some major increment of the Department of the Navy's formalized training effort.

**TRAINING AIDS:** (Synonymous with INSTRUCTIONAL AIDS): Any item which is developed and/or procured with the primary intent that it shall assist in training and the process of learning. This does not include instructional literature and logistic support equipment. Various training aids are:

- |                        |                         |                                   |
|------------------------|-------------------------|-----------------------------------|
| 1. Audio Cassette      | 7. Dynamic Demonstrator | 13. Model                         |
| 2. Audio Tape          | 8. Flight Simulator     | 14. Operable<br>Transparency      |
| 3. Audiovisual Aid     | 9. Graphic Aid          | 15. Operational flight<br>trainer |
| 4. Cutaway             | 10. Loop Film           | 16. Simulators                    |
| 5. Cyclic Demonstrator | 11. Manipulative Aid    | 17. Training Device               |
| 6. Demonstration Aid   | 12. Mock-up             | 18. Videotape                     |

**TRAINING CAPABILITIES TEST AGENT:** An independent agent selected to develop and perform the TCT as specified in the Training Equipment Test and Evaluation Plan (TETEP). Independent agent is defined as a command or agency independent of the developing, procuring, and using commands.

**TRAINING COMPLEX:**

1. A number of "Training Equipments" and "Training Devices" which may be installed at an activity in such manner that they may be operated in combinations with each other. Installations of this type are spoken of as "Training Complexes."

2. Combinations or groups of schools, training units or commands, etc., under a single officer in command, or at a single locality.

3. A specific linkage of common service between schools, equipments, etc.

**TRAINING DECISION ALTERNATIVES PROPOSAL:** The TDAP is an RDT&E document which lists alternate solutions and trade-offs designed to achieve a particular range of capabilities in response to the Training Operational Requirement (TOR) document. Cost-benefit and technical considerations are provided to assist the resource sponsor in the selection among the alternatives.

**TRAINING DEVICE:** Consists of hardware and software which have been designed or modified exclusively for training purposes, involving, to some degree, simulation or stimulation of some type in its construction or operation, with the required methodological and evaluation techniques to train, refresh, or expose personnel, or groups of personnel as an entity to a reassured level of performance proficiency.

**TRAINING EFFECTIVENESS COST EFFECTIVENESS PREDICTION (TECEP):** A technique used to accumulate and use cost data. The TECEP technique provides an orderly approach to making delivery system choices during the design phase of instructional systems development. The procedure for the TECEP technique is presented in NAVEDTRA 108.

**TRAINING EFFECTIVENESS EVALUATION AGENT:** An independent agent selected to develop and perform the TEE as specified in the Training Equipment Test and Evaluation Plan (TETEP). Independent agent is defined as a command or agency independent of the developing, procuring, and using commands.

**TRAINING EQUIPMENT TEST AND EVALUATION PLAN:** The control document in the RDT&E acquisition process (OPNAVNOTE 5000). The TETEP includes: training requirements, engineering specifications, facilities specifications, and a comprehensive test and evaluation plan. The TETEP defines objectives, procedures, required resources, and time scheduled for Development Tests (DT), Training Capabilities Tests (TCT), and, when requested by CNET, Training Effectiveness Tests (TEE).

**TRAINING, FIRST AND SECOND GENERATION:**

1. First Generation. Training of naval personnel by factory technicians at industrial sites to qualify the former to teach at Navy schools the maintenance skills appropriate to sophisticated hardware.

2. Second Generation. Training of naval personnel by first generation trained instructors at Navy schools to qualify the former as maintenance specialists for sophisticated hardware.

## Technical Report 118

**TRAINING OBJECTIVE:** A statement of the ultimate purpose to which the trainee expects to put the skills acquired through his training program. Example: to be able to perform the duties of an apprentice machinist's mate aboard a 1200 psi steam-driven turbine-powered ship.

**TRAINING OBJECTIVE STATEMENTS (TOS):** A group of statements which describe the system, subsystem, or equipment knowledge depths and skill levels to be attained in support of coordinating, directing, and performing operation and maintenance. They define depth and level of training coverage for Personnel Performance Profile items.

**TRAINING OPERATIONAL REQUIREMENT:** A concise statement of training needs and the basic requirement document for all Navy training acquisition programs requiring RDT&E. The TOR directs NAVMAT to prepare a Training Decision Alternatives Proposal (TDAP).

**TRAINING PROGRAM COORDINATOR (TPC):** A member of a functional commander's staff who coordinates the training conducted in an assigned group of schools/-courses.

### **TRAINING READINESS:**

1. The quality of being up-to-date; i.e., able to provide training on the very latest model, device, technique, or information.
2. The capability to train; i.e., has the means to train in a specified area of content.
3. The quality of being ready to undertake the training for which scheduled; i.e., ready to be instructed and to benefit from the instruction.

**TRAINING RESEARCH, DEVELOPMENT, TEST AND EVALUATION:** Involves the conduct of research, development, test and evaluation under the Navy RDT&E program of new concepts, principles, and methods and techniques, and systems of learning, teaching, and program planning and administration.

### **TRAINING REQUIREMENT:**

1. A requirement to train personnel in a specified quantity to perform identified duties and thereafter be available for assignment to the duties at a specified time.
2. A need, established by the training organization, for training support of specified nature.

**TRAINING REQUIREMENTS AND INFORMATION MANAGEMENT SYSTEM (TRIM):** A mechanized integrated data processing system for management of training information for military and civilians.

Technical Report 118

**TRAINING REQUIREMENT NEEDS ANALYSIS (TRNA):** A preliminary assessment of the training situation including: statement of training problem, training objectives, tentative solutions, and cost-benefit analysis.

**TRAINING REQUIREMENT STATEMENT:** A concise statement of current or anticipated training deficiencies or needs that have a high perceived probability of solution with the use of some type of training aid or device.

**TRAINING SITUATION ANALYSIS:** An analytic procedure for determining the nature of the tasks to be accomplished in work performance, and classifying these tasks in a framework of frequency, difficulty, and criticality. The results of the analysis form the basis for recommendations for training device concepts and functional characteristics.

**TRAINING SPECIFICATIONS:** A detailed description for the development of the job task analysis (job analysis), instructional materials and the conducting of courses designed for preparing technical personnel to perform assigned tasks within their occupational fields.

**TRAINING STAFF:** The administrators and instructors assigned to a training activity.

**TRAINING STANDARD:** A quantitative or qualitative measure for the determination of a level of competence or readiness. A standardized procedure or exercise.

**TRAINING STATISTICS:** Quantitative information, standards, definitions and formulas required for the analysis, management and monitoring of training efficiency and effectiveness.

**TRAINING SUPPORT:** The providing of resources, such as billets, personnel, funds, facilities, hardware, course materials, and services for the use of the training organization.

**TRAINING SUPPORT AGENCY:** A bureau, command, office or headquarters responsible for supporting the training agencies by providing material and other forms of support within the cognizance of the bureau, command or office involved.

**TRAINING SYSTEMS ANALYSIS:** Prescribed process for placing jobs for which training is to be designed in perspective with job requirements, objectives, resources, and the overall environment of the training or operational system. See also TRAINING REQUIREMENT.

**TRAINING TASK ANALYSIS:** A system for proceeding from an inventory of tasks, such as that provided by a job task analysis (job analysis), to an organized set of terminal, learning and enabling objectives.

**TRAINING UTILIZATION:** The extent to which the capacity of a training activity, school, device, or course is being used.

Technical Report 118

**TRANSFER OF TRAINING EFFECTIVENESS EVALUATION:** Tests specifically performed to determine the extent of transfer of training from the training to the operational environment.

**TRANSPORTABILITY:** Inherent capability of material to be moved by towing, by self-propulsion, or by carrier via railways, highways, waterways, pipelines, ocean, and airways. (OPNAV 4600.22)

**VULNERABILITY:** The characteristics of a system which causes it to suffer a definite degradation (incapability to perform the designated mission) as a result of having been subjected to a certain level of effects in an unnatural (man-made) hostile environment. (DODDIR 5000.3)

**WEAPONS SYSTEM TRAINER (WST):** A trainer which provides a synthetic flight and tactics environment in which pilots and flight crews learn, develop and improve the techniques associated with their individual tasks in a specific type of aircraft, and operate as a team in the execution of simulated missions, such as an anti-submarine warfare search, radar intercept, attack, etc. The trainer is an electro-mechanical system simulating the aircraft flight and engine characteristics and systems operation, and providing appropriate instrument indications resulting from operation of controls in the cockpit and flight crew compartments. The device includes an instructor station for establishing problem parameters, introducing malfunctions, and monitoring and recording trainee performance.

**WORKLOAD:** A term used in the Military Manpower Training Report to identify student AOB for a service's training entity; e.g., course, school, activity, command, or training category. Includes all students--own service, other service, foreign, and civilian. Within a pertinent training entity. A workload is computed in the same manner as AOB.

**WORK BREAKDOWN STRUCTURE:** A product-oriented family tree division of hardware, software, services and other work tasks which organizes, defines and graphically displays the product to be produced as well as the work to be accomplished to achieve the specified product. (DOD 7000.2)

**WORK PACKAGES:** Detailed short-span jobs, or purchased material items, identified by the contractor for accomplishing work required to complete the contract. (DOD 7000.2)

**WORK UNIT:** The smallest segment into which research and technology efforts are normally divided for purposes of local administration. (DOD 7720.13)

**WORKWEEK:** The number of hours per week which the training activity is required to operate as a matter of policy.

Technical Report 118

ANNEX B

SUBMARINE TRAINER WORKING GROUP (STWG)  
GUIDELINES, REVISION A

26 November 1980  
Revision A

SUBMARINE TRAINER WORKING GROUP  
(STWG)  
GUIDELINES  
REVISION A

Prepared by: CNET N-945

Enclosure (1)

## FOREWORD

In October 1975, the Chief of Naval Operations (CNO) (Op-29) formally established the Submarine Trainer Working Group (STWG) and identified its basic charter as the identification of major trainers required to support submarine training. (Reference CNO letter serial 29P/99677 of 7 October 1975.) The STWG has effectively fulfilled that charter and is recognized as a credible influence in obtaining resource support for submarine trainers. This document supersedes the original STWG guidelines dated 1 October 1976, including subsequent revisions, and provides the current objectives structure and guidelines of the STWG.

These guidelines were approved by CNO (Op-29), reference CNO ltr serial 29P/386738 20 January 1981.

SUBMARINE TRAINER WORKING GROUP  
GUIDELINES

1. Purpose. The purpose of this document is to identify and establish the objectives and guidelines for the conduct of the STWG. In addition, the general organizational concepts as applied to submarine trainers are provided for information purposes.
2. Objectives. The major objectives of the STWG are as follows:
  - a. To provide direct support to the Fleet Submarine Training Review Board (FSTRB) in matters regarding submarine trainers.
  - b. To ensure the timely identification of trainer needs, commensurate with the Navy planning, programming, and budgeting system and the Navy training planning process.
  - c. To provide the overall direction regarding planning for submarine trainers, trainer modifications, and major submarine training aids.
  - d. To provide guidance and direction relative to submarine trainer management issues.
  - e. To identify and establish submarine trainer Fleet Project Teams (FPT) or other subcommittees as may be required in the management of trainers.
3. STWG Structure/Representation. The STWG includes representation from the majority of major commands/activities involved with submarine trainers. The STWG is co-chaired by CNO (Op-29) and Chief of Naval Education and Training (CNET) (Code N-945). The STWG membership is listed in Appendix A which also identifies correspondence distribution. Specific points of contacts and telephone numbers are provided with each STWG minutes.
4. Fleet Project Teams (FPT). Fleet Project Teams for submarine trainers are designated by the STWG. The conduct and responsibilities of the FPT's are identified in OPNAVINST 1551.7B. The only exception/clarification regarding submarine trainer FPT's is that their efforts are considered to continue throughout the life cycle of the trainer rather than to terminate upon acceptance. The FPT is also considered as the change requirement authority for each trainer series. Current FPT assignments are reflected in Appendix B. The chairman of each FPT is considered as a member of and responsible to the STWG.
5. STWG Guidelines
  - a. STWG Meetings. The STWG will conduct meetings semiannually. Other meetings will be called for special purposes as appropriate. Generally the two annual meetings will be scheduled to air issues and facilitate direction/requirements preparatory to POM/budget submission events. The meetings are normally scheduled for April and October of each year. CNET will announce the meetings and provide a tentative agenda. STWG representatives provide issue papers for proposed agenda items in early March or September of each year.

b. STWG Meeting Conduct. The basic intent of the meeting is that it be workshop oriented; however, a certain amount of general STWG business must be conducted. In order to utilize the meeting time most productively, the following guidelines are provided:

(1) New issues for STWG discussion/review shall be the subject of a detailed issue paper, submitted to CNO (Op-29) and CNET (Code N-945), at least 30 days prior to the meeting, with copies to those organizations the issue involves. Upon receipt STWG representatives are to conduct the necessary staff work to ensure that the issue can be appropriately discussed/supported, etc., at the STWG meeting with the pertinent facts germane to each respective organization's responsibility.

(2) STWG representatives should be completely prepared to address the issues for which they are responsible including providing the appropriate handouts of presentation material for the STWG record.

(3) STWG representatives assigned action during the course of the meeting are required report completion as it occurs, or provide status to the CNET co-chairman at least three months following the meeting and one month prior to the next meeting, for still unresolved actions.

(4) Commands/activities are to keep representation to only the essential minimum, recognizing that in case of special issues, backup technical representatives may be required.

(5) Contractor representation is not permitted without the expressed consent of CNO (Op-29).

c. STWG Meeting (Basic Agenda)

(1) Opening remarks.

(2) Review of open action items. Will include a review of only current open action items. Items which were reported complete prior to the meeting will be reflected in a handout. Representatives responsible for open action items should be prepared to address the current status.

(3) Submarine Trainer Planning Overview. The purpose of this item is to identify/provide status of all submarine trainers in either the RDT&E or OPN POM planning, and current programs in the development phase. The following applies:

(a) RDT&E Plans. A brief status by CNO (Op-29) on RDT&E planned trainer programs.

(b) OPN POM Plans. Identification of trainers which are in the OPN POM planning process including approved new starts.

(c) Current trainer programs. The status of ongoing programs are to be addressed by the responsible development agent, i.e., SSPO, COMNAVSEASYSOM, or NAVTRAEQUIPCEN. The planning schedules provided per

paragraph 5e will reflect the current programs. The major purpose of this item is to address only problem areas which require STWG visibility/ direction. The problems may be with the trainer itself or it can relate to associated items, i.e., GFE, MILCON, personnel, etc. Preparation cited in paragraphs 5b(1), (2) applies.

(4) Review of submarine training aid requirements. A review of training aid requirements which are considered as investment items. (\$3,000 or greater)

(5) Review of submarine trainer changes. A review of all unfunded changes to submarine trainers sponsored by CNET. Changes to be included are technical change proposals, engineering change proposals, and modifications over \$20K or those which may be of special interest to the STWG. The NAVTRAEQUIPCEN will distribute a list of the changes to be reviewed prior to the meeting in order for planning priorities to be staffed.

(6) New business. A workshop oriented session regarding major issues submitted for STWG consideration. Paragraph 5b(1) applies.

d. STWG Minutes/Actions. CNET is responsible to issue the minutes for each STWG meeting.

e. STWG Quarterly Status Report. A report prepared by the Naval Training Equipment Center, quarterly, providing status of major trainers. The report is to reflect inputs from each training activity regarding facilities for trainers and also reflect status of trainer efforts conducted by the NAVSYSCOMs or SPPO. The report is distributed by the Naval Training Equipment Center to all STWG representatives.

f. STWG Travel. Each command is responsible for providing designated representatives with appropriate travel resources.

g. STWG Mail Distribution. See Appendix A.

11 November 1980

SUBMARINE TRAINER WORKING GROUP GUIDELINES  
APPENDIX A  
MEMBERSHIP AND CORRESPONDENCE DISTRIBUTION

DISTRIBUTION LIST

SNDL ID

STWG MEMBERSHIP

A3	CNO (Op-29) (2 cys)
C4K	CHNAVMAT (PM2-52) TRIDENT SYSTEM PROJECT
FT1	CNET (N-945)
FT5	CNTECHTRA (N41) (2 cys)
24H1	COMTRALANT (N54)
24H2	COMTRAPAC
24G1	COMSUBLANT (N24)
24G2	COMSUBPAC (N1)
FT46	CO, FLEASWTRACENLANT (60)
FT46	CO, FLEASWTRACENPAC
FT23	CO, FLEBALMISUBTRACEN (01/40)
FKA1G	COMNAVSEASYSYCOM (PMS409A12) (2 cys)
FT54	CO, NAVSUBSCOL (00) (3 cys)
FT38	CO, NAVSUBTRACENPAC
FT95	CO, SUBTRAFAC
FT64	CO, NAVTRAEQUIPCEN (N81U) (6 cys)
C37A2	OIC, NUSCDET, New London (32) (3 cys)
FKA6A15	CO, NUSC, Newport (3551) (2 cys)
C4K	DIR, SSPO (SP15) (2 cys)
FT85	CO, TRITRAFAC, Bangor (N3/9)
FS3	CO, NISC

STWG Minutes only copy to:  
CNO (Op-01, 39)  
CNET (N-313, N-213, N-95)  
COMNAVELEXSYSCOM (PME-107)  
COMNAVFACENCOM (PC-6)  
CO, NAVEDTRASUPPCENLANT  
CO, NAVEDTRASUPPCENPAC  
CO, NAVTRAEQUIPCENREPLANT  
CO, NAVTRAEQUIPCENREPPAC  
CO, NAVTRAEQUIPCENFEO, Pearl Harbor

Distribution: 21 activities/35 copies  
13 copy to for STWG minutes only

Revision A  
Appendix A  
Page 1 of 1

STWG GUIDELINES  
APPENDIX B

Submarine Trainer  
Fleet Project Team (FPT) and  
STWG Subcommittee Assignments

It is general STWG policy to assign FPT chairmanship responsibilities to one or both of the submarine type commanders, (COMSUBLANT, COMSUBPAC) for trainers supporting fleet training. The effort involved with the FPT consumes considerable time and in many cases a training command/activity may be designated as co-chairman to provide support to the type commander. It should be noted, however, that all FPT deliberations, decisions, or recommendations, involving fleet trainers, are to be appropriately coordinated with the type commander, in instances where direct participation may be precluded by non-availability of personnel. OPNAVINST 1551.7B applies.

<u>Trainer/Subject</u>	<u>Fleet Project Team</u>
21B64 Series (AN/BQQ5 Sonar Operator Trainer)	COMSUBLANT/PAC Co-Chairman NAVSUBSCOL Co-Chairman FLEASWTRACENLANT FLEASWTRACENPAC FLEBALMISUBTRACEN NAVSUBTRACENPAC SUBTRAFAC COMNAVSEASYSKOM (PMS409) NAVTRAEQUIPCEN NUSC (NLON) NISC
SSBN SOT (Sonar Operator Trainer)	COMSUBLANT Co-Chairman FLEBALMISUBTRACEN Co-Chairman NAVSUBSCOL SSPO (SP-15) NAVTRAEQUIPCEN NUSC (NLON)
14E31A (AN/BQQ5 Sonar Operator Trainer)	CNTECHTRA Co-Chairman FLEASWTRACENPAC Co-Chairman COMNAVSEASYSKOM (PMS409) NAVTRAEQUIPCEN NUSC (NLON) COMSUBLANT COMSUBPAC

\*21A Series  
(Combat Control  
System Trainers)

COMSUBLANT/PAC Co-Chairman  
CNET Co-Chairman  
NAVSUBSCOL  
FLEASWTRACENLANT  
FLEBALMISUBTRACEN  
SUBTRAFAC  
NAVSUBTRACENPAC  
NAVSEASYSKOM (PMS409)  
NAVTRAEQUIPCEN  
SSPO (SP-15)  
NUSC (NLON)  
NUSC (NWPT)  
TRIDENT SYSTEM PROJECT OFFICE

\* Includes 21B63 series update to a 21A series, and SMARTTS (Submarine Advanced Reactive Tactical Training System)

AVEOSS  
(Advanced Visual/Near  
Visual Electro-Optic  
Sensor Simulator)

COMSUBLANT/PAC Co-Chairman  
NAVSUBSCOL Co-Chairman  
FLEBALMISUBTRACEN  
NAVSUBTRACENPAC  
SUBTRAFAC  
NAVELEXSYSKOM (PME-107)  
NAVSEASYSKOM (PMS409)  
NAVTRAEQUIPCEN

15F12A/B Series  
(Navigation/Piloting  
Trainers)

COMSUBLANT/PAC Co-Chairman  
NAVSUBSCOL Co-Chairman  
FLEBALMISUBTRACEN  
NAVSUBTRACENPAC  
SUBTRAFAC  
FLEASWTRACENLANT  
TRITRAFAC  
NAVTRAEQUIPCEN

21C6 (Damage Control  
Trainer)

COMSUBLANT Co-Chairman  
FLEBALMISUBTRACEN Co-Chairman  
NAVSUBSCOL  
FLEASWTRACENLANT  
NAVTRAEQUIPCEN

Diving Control Trainers  
(21C7, 21B56 Series)

COMSUBLANT/PAC Co-Chairman  
NAVSUBSCOL Co-Chairman  
\* FLEASWTRACENLANT  
FLEBALMISUBTRACEN  
NAVSUBTRACENPAC  
SUBTRAFAC  
NAVTRAEQUIPCEN

\* Change Requirement  
Coordinator

Submarine Fire Fighting  
Trainers

COMSUBLANT/PAC Co-Chairman  
NAVSUBSCOL Co-Chairman  
NAVTRAEQUIPCEN  
NAVSAFECEN

STWG Subcommittee/Team

21A/21B64 series  
Interface Technical  
Management Team

NAVSEASYSKOM (PMS409) Chairman  
NAVTRAEQUIPCEN  
NUSC (NWPT)  
NUSC (NLON)

21A/SSBN SOT  
Interface Technical  
Management Team

NAVSEASYSKOM (PMS409) Chairman  
NAVTRAEQUIPCEN  
SSPO (SP-15)  
NUSC (NWPT)  
NUSC (NLON)

3 October 1980

SUBMARINE TRAINER SYSTEMS  
GENERAL INFORMATION GUIDE FOR  
STWG  
REPRESENTATIVES

Prepared by: CNET (Code N-945)

STWG Guidelines Appendix C

## INTRODUCTION

This information guide is intended to provide STWG representatives with general information and general guidance relative to the processes involved with the identification, planning, budgeting, and execution required for a "trainer system" and its associated elements. The information provided, for the most part, is derived from current Navy directives which are to be considered the official implementing directives and are not to be considered as proliferated or superseded by this document.

1. Planning and Development. A "trainer system" involves the "trainer" as shown in Figure 1, and several other major associated elements as depicted in Figure 2, all which require synchronous planning and/or development. Of these elements those which normally require the most attention are the trainer, associated military construction (MILCON), and operational equipment (when applicable) used as part of the trainer. The following provides information relative to the planning and development interrelationships of these elements and is intended to illustrate the necessity of "early identification" of needs and the coordination required:

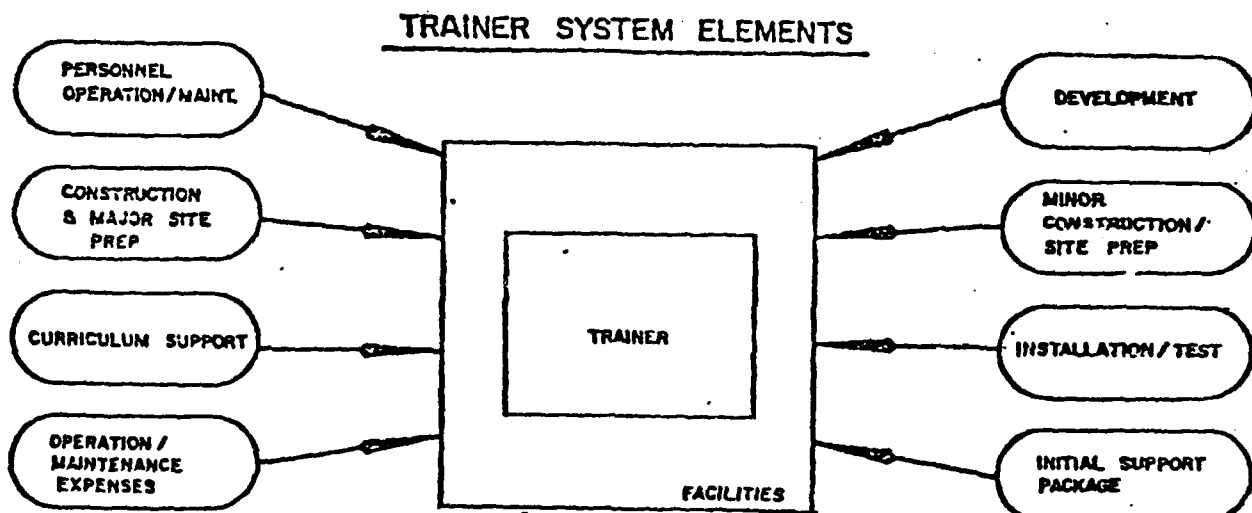
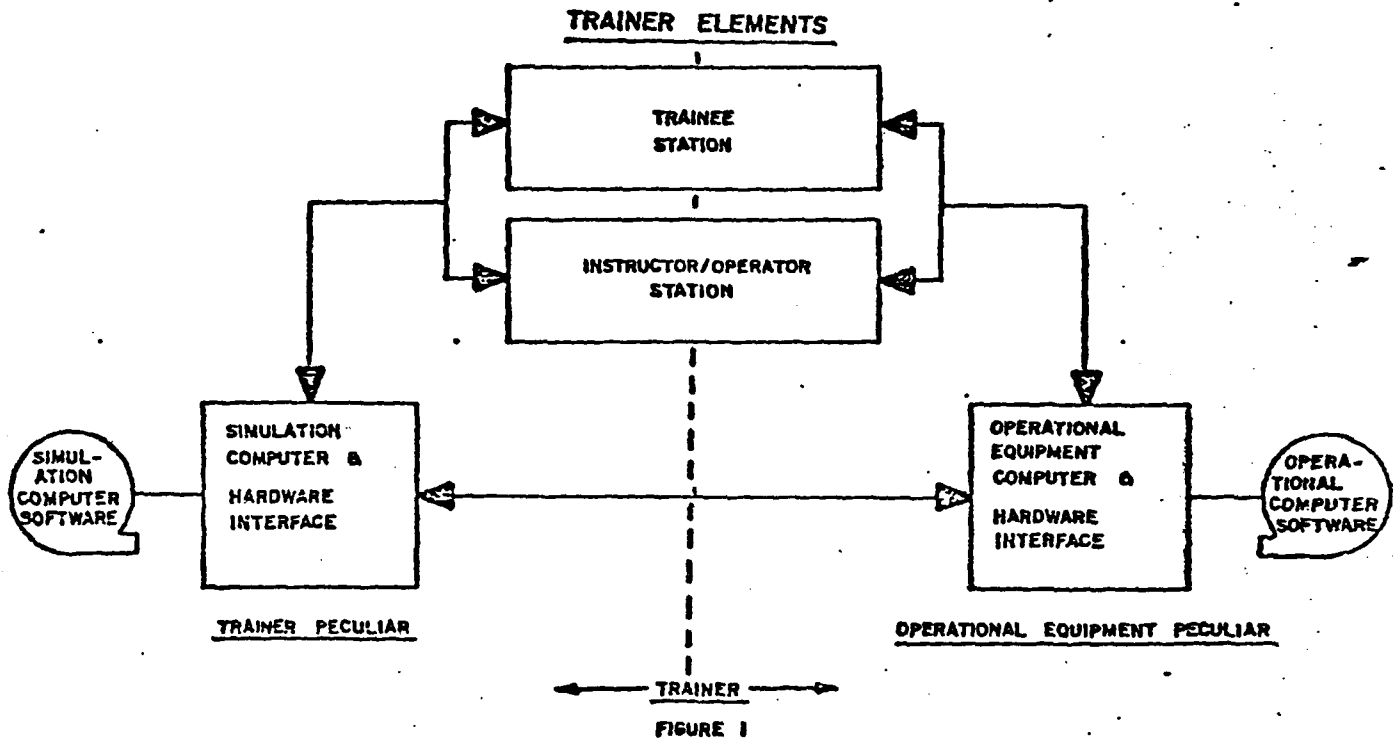

a. Trainer Planning. Funding resources to support trainer developments are obtained through the Navy Program Objectives Memorandum (POM) process. Under normal conditions a minimum of a 2-year cycle is inherent prior to the allocation of trainer funding. Example: A request for funding in October 1980 (POM 83) would reflect requirements for FY 83 through FY 87. Trainers programmed for FY 83 would realize funding on or about October 1982 (start of FY 83), at which time the development process could be executed. The trainer development cycle time can vary as much as 9 to 24 months. Under a RDT&E trainer development, the funding profile normally reflects the 3-year program with the completion of the development process somewhere between 12 to 18 months after the second fiscal year funding (a minimum of 5 years for the planning and development cycle).

b. Military Construction (MILCON). In some instances new military construction may be required to provide the facilities to house the trainer. In these cases an additional 2 years may have to be added to the total planning cycle, to account for the construction planning and development. MILCON above \$4M must be programmed one year after the POM year. Example: A MILCON Project of \$5M submitted for POM 83 can only be funded in FY 84 or later.

c. Operational Equipment. In instances where ships operational equipment is to be an integral part of the trainer system (i.e., stimulated by a simulation interface of the trainer), the planning for that operational equipment development and installation must be keyed to the trainer development timing. In most cases the equipment is required within 6 months after contract initiation of the trainer development process. Unless readily available from existing assets, planning and development time is required to produce the required operational equipment units for trainer use. The planning and development lead time can involve as much as 3 years and may require leading the trainer planning cycle by at least one year.

## 2. Trainer Funding Policy

a. Germane to the planning and development lead time is the basic policy regarding which appropriation trainers are funded by:

- (1) RDT&E      Trainer developments which require the development of new "trainer system computer software" are to be funded with RDT&E appropriations.
- (2) OPN        Trainers not falling into the above RDT&E category and all follow-on units to the RDT&E development are to be funded with OPN appropriations. In the case of follow-on units, they can be programmed only in the fiscal year which is subsequent to the fiscal year that the RDT&E unit, design review is scheduled for completion.  
Example: If the RDT&E unit design review is scheduled for November 1982 (FY 83), then the follow-on unit could be programmed for FY 84 and not earlier.

\*It is noted that under a trainer OPN procurement, some items such as factory training or other designated items may be considered as an expense (O&MN).

b. Trainer System Element Funding. In addition to the trainer funding, other trainer system elements are funded through separate appropriations, e.g., OPN, BA2, BA4, MILCON, OGMN, etc., necessitating synchronous planning.

3. Organization. Figure 3 depicts the basic organization involved with submarine trainers. For the purpose of this document, the organization addresses itself to shore based training and identifies those activities/commands with prime interest in the training requirement, the training and the training material support. For the purpose of relating the trainer system elements to the organization depicted in Figure 3, the following functional titles are provided:

SUBMARINE TRAINING ORGANIZATION

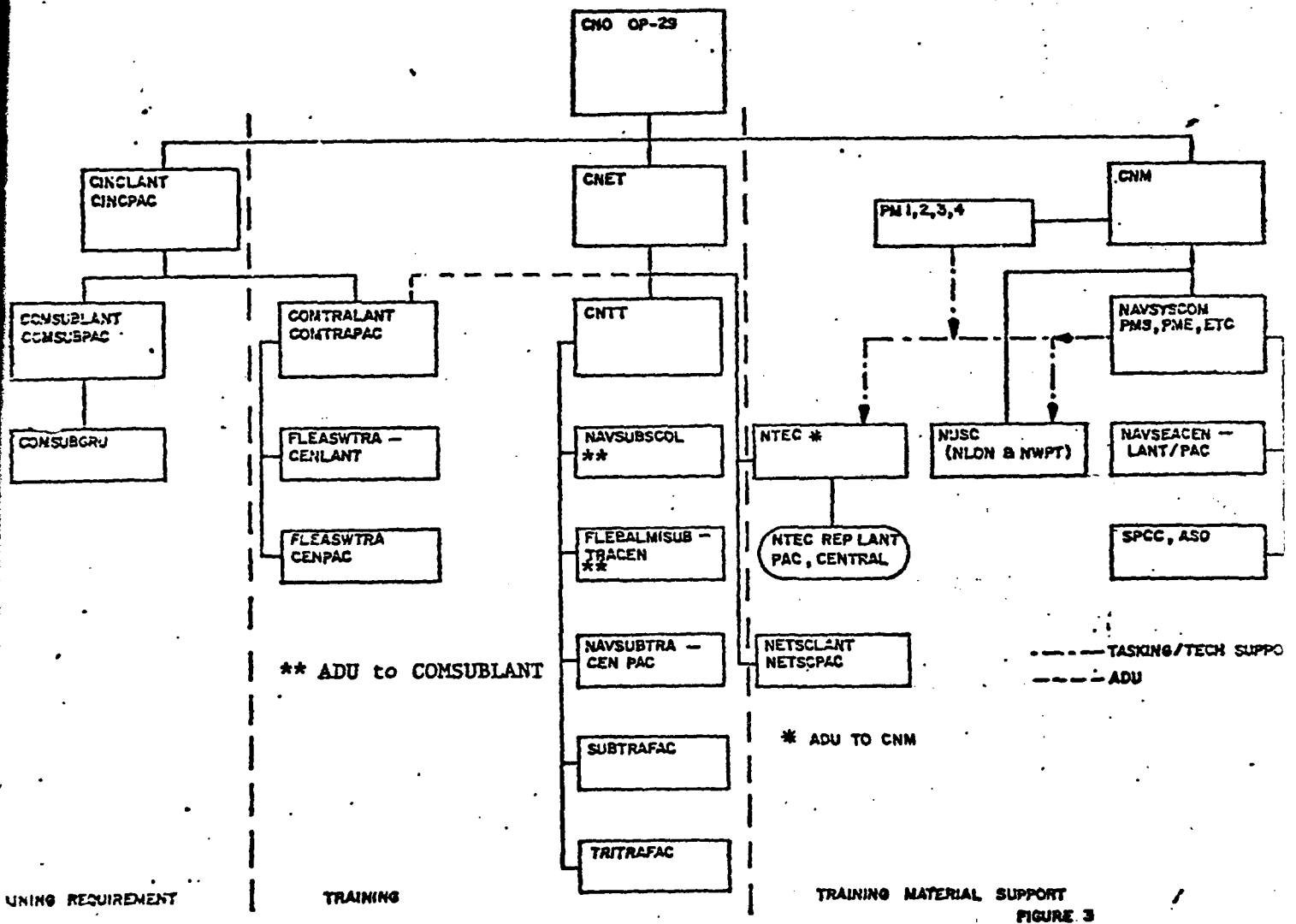

a. Resource Sponsor. The resource sponsor for submarine trainers is CNO (Op-29). The resource sponsor "establishes" all training requirements based on identified trainer needs and provides overall management and direction to the program.

b. Fleet Commanders. The fleet commanders are CINCLANT and CINCPAC.

(1) Type Commanders. Submarine type commanders are COMSUBLANT and COMSUBPAC. The type commanders are responsible to identify the qualitative and quantitative training requirements as related to fleet refresher and predeployment training. The type commanders also identify potential training deficiencies as relates to submarine pipeline training. As designated co-chairman of the majority of trainer fleet project teams, the type commander is to assure that the functional needs of the trainer are appropriately identified and implemented to satisfy established requirements.

c. Training Agent. The CNET is the training agent for submarine pipeline training, and a co-agent with the fleet commanders for fleet training conducted at CNET training activities. In this capacity, CNET is responsible to provide direct training support for identified fleet training needs. As training agent CNET identifies the need for resources, i.e., trainers, facilities, personnel and support, with appropriate consultation to the resource sponsor. The following commands and activities fall under the command responsibility of CNET.

(1) Functional Commanders. The functional commanders include the Chief of Naval Technical Training (CNET), the Commander Training Command, U.S. Atlantic Fleet (COMTRALANT), and the Commander Training Command, U.S. Pacific Fleet (COMTRAPAC). The functional commanders have command responsibility for the training activities within their organizational structure. As functional commanders they are responsible to CNET for the conduct of the training and the identification of all resource requirements to support that training. In addition, training curriculum control activities reside within the functional commands.

(a) Training Activities. There are seven training activities associated with the majority of submarine pipelines. Training activities conduct the training for both basic submarine pipelines and officer pipelines as well as refresher and predeployment training in support of fleet needs. The majority of resources required to support training ultimately are destined for the training activities that have responsibility for their use and support at the organizational level. The activities are responsible to the functional commanders in the identification of needs to support the training for which they are responsible. In addition, a lead training activity is normally appointed as a co-chairman of the trainer fleet project teams to ensure that the trainers are appropriately specified and developed to satisfy the training need.

d. Training Material Support. Training Material Support is drawn from many Navy commands and activities, all of which play key roles in the technical development and support of the trainer. For the purpose of this document, the key function, with regard to trainer development, shall be identified as the trainer development project manager (TDPM). The TDPM is considered to have the overall responsibility to ensure that the trainer systems are developed, installed, and supported consistent with the established requirements. The commands/activities that support trainer development

elements form a complex organization which cuts across many command lines and requires coordination and team work to ensure a successful outcome. In some cases, e.g., the combat control system trainer situation, a "formal technical organization is identified/structured to ensure the continuity and congruity of the program."

(1) Trainer Development Program Manager (TDPM). The TDPM for the majority of submarine trainers is the Naval Training Equipment Center (NAVTRAEQUIPCEN), Orlando, FL. In some cases, e.g., trainers which support a new submarine system or special trainer project, a CNM project manager or SYSCOM may be assigned as the overall trainer technical program manager. Within the structure of the TDPM will fall other support functions, e.g., Technical Design Agent (TDA), In-service Engineering Agent (ISEA), etc.

(2) Operational System Training Support Agent. Aside from the functions which may be established as TDPM, the SYSCOMs have established responsibilities for the operational equipment which is considered as a part or is stimulated by a trainer system. The responsibilities for planning, budgeting, development, and installation, and in-service engineering support of operational equipment resides with the various cognizant NAVSEA program offices, e.g., MK 117, NAVSEA PMS409.

(3) Trainer Development Technical Support Agents. This term is used to cover a wide variety of the Navy organizations which contribute to the development of the trainer. Various technical commands/activities including NAVTRAEQUIPCEN, NUSC, NAVSEACENLANT, NAVSEACENPAC, etc., may at some time serve in this role.

4. Major Events. Figure 4 identifies the major events associated with submarine trainer development and provides a general guide relative to the responsibilities associated with each event.

AD-A115 608 TRAINING ANALYSIS AND EVALUATION GROUP (NAVY) ORLANDO FL F/G 5/1  
A MANAGEMENT SYSTEM FOR RDT&E FUNDED TRAINING DEVICE ACQUISITIO--ETC(U)  
UNCLASSIFIED APR 82 R V NUTTER, W R TERRELL TAEG-TR-118 NL

2 of 2

ADA  
ISEDR

END  
DATE  
FILMED  
07-82  
DTIC

MAJOR EVENTS  
SUBMARINE TRAINER SYSTEM

ENT	DESCRIPTION	LEAD	DOCUMENT	REMARKS
1	<p><u>Initial Identification of the Trainer Need.</u> The initial identification of the basic need for the trainer includes:</p> <ul style="list-style-type: none"> <li>a. General description of the training situation:               <ul style="list-style-type: none"> <li>(1) Basic training objectives to be met</li> <li>(2) Student type and loading</li> <li>(3) Training courses involved/locations</li> <li>(4) Anticipated trainer utilization (trainer hours)</li> </ul> </li> <li>b. Rationale as to why a trainer is needed vice some other type of training media.</li> <li>c. A general description of the trainer functional capabilities envisioned.</li> <li>d. Statements relative to estimated impact on facilities/staffing required for the trainer.</li> </ul>	Any source or as assigned by STWG	Issue Paper	Submitted to CNO (Op-29) with copy to CNET (N-945).
2	<p><u>STWG Review.</u> An initial review of the trainer need, resulting in specific action regarding further disposition. The issue is normally presented by the initiator or action assignee and the results reflected in the STWG minutes.</p>	STWG	STWG Minutes	Events 2, 3, 4, and 5 may in some instances be consolidated for a single STWG review.
3	<p><u>Trainer Need Validation.</u> In the majority of cases, the trainer need will require validation staffing outside of the STWG. The Fleet Submarine Training Revision Board (FSTRB) agent will be requested to validate the</p>	FSTRB Training Agent	Letter with finalized Issue Paper	

need. Upon validation the training agent finalizes the initial issue paper reflecting any validation changes and requests technical staffing.

4 Technical Staffing. Based upon the finalized issue paper technical staffing is accomplished to identify:

- a. Technical feasibility
- b. Design concept/alternatives
- c. Estimated acquisition cost estimate
- d. Life cycle cost estimate
- e. Risk areas if any

ZDPH

Technical Addendum to the Issue Paper

5 STWG Review. The review by the STWG which leads to the "establishment" of the trainer requirement. The establishment of the requirement includes:

- a. Designation of the Trainer Fleet Project Team
- b. POM guidance relative to
  - (1) RDT&E or OPN
  - (2) Trainer locations
  - (3) Fiscal year plan
- c. Target date for establishment of the Trainer Functional Baseline

STWG

STWG minutes

The major events which follow involve the detailed identification, planning, budgeting, and execution of the trainer systems. The two major paths, i.e., RDT&E and OPN involve some variance in methodology and documentation. In each instance, however, the responsibilities of the submarine training organization does not vary significantly at all.

6 Trainer Requirement Baseline. The formal documentation of the "General Trainer Requirement" (GTR). For RDT&E trainers the GTR takes the form of an Operational Requirement (OR) document. For OPN trainers the Issue Paper serves as the baseline document. The training agent is responsible for the development of the trainer requirement baseline document and where fleet training is applicable, conducts the appropriate coordination with the TYCOMs.

Training Agent

7 Trainer System Resource Planning. The Navy POM process involves the development/submission of formally structured documentation. For RDT&E, the documentation includes Navy Decision Coordination Papers (NDCP), Mini-MIPs, and Resource Requirement Requests (training agent resources associated with a RDT&E trainer are submitted via RRR to the resource sponsor). For OPN trainers the process involves Budget Justification Sheets (BJS) and RRRs, both submitted by the training agent to the resource sponsor. The documentation for RDT&E trainers is submitted by the TDPH to the resource sponsor through the Chief of Naval Material chain. In all cases the integrity of the trainer requirement baseline is maintained. The events outlined below deal with trainer system elements which normally involves a planning path somewhat independent of the trainer planning path.

NDCPs  
MINI-MIP  
BJS  
RRR

TDPH

a. Facilities Requirements. The responsibilities for facilities varies with the scope of the effort required to provide suitable housing for the trainer. During the early planning stage it is imperative that these responsibilities be clearly established to assure that the total effort is synchronized with the trainer

TDPH

Facilities Requirement Criteria

The data is required at least 30-45 days prior to an NDCP or BJS submission by the TDPH

development planning. The initial action involves the TDPH providing the training agent with specific definition of the facility requirements in terms of space, environment, power, lighting, cooling water, etc.

The training agent through each respective training activity and functional command will make the initial determination whether or not a military construction (MILCON) project is required. In cases where a MILCON effort is not appropriate (normally \$100K or less), it is intended that the TDPH assume responsibility for the minor construction/site preparation as part of the trainer development under a "turnkey" type operation.

b. Trainer Staffing, Personnel Requirements. The training agent is responsible to provide the personnel (military or civilian) required for the life cycle operation and maintenance of the trainer subsequent to its acceptance for training. The TDPH provides the training agent with a document which provides an estimate of the type, number, and grade of personnel required. The training agent, through its training activities and functional commands, utilizes these estimates as the basis for determination of additional personnel and subsequent submission via RRR to the resource sponsor.

c. Operation/Maintenance Expenses. The training agent is responsible for the expense (O&MN) resources associated with the trainer operation and maintenance after its acceptance for training. These resources encompass funding for parts, consumables, etc., at the

Training Agent

Letter Feedback to TDPH

TDPH

Personnel Staffing Estimate

The personnel data is required concurrent with RJS or NDCP submissions.

TDPH

Operational/Maintenance Expense Estimate

The expense data is required concurrent with the RJS or NDCP submission.

organizational, intermediate, and depot levels. The resources apply to operational equipment as well as trainer peculiar equipment. The TDPH provides the training agent with an estimate of these annual expenses.

d. Operational Equipment. In cases where the concept for a trainer employs operational equipment as part of its design, the TDPH is responsible to initiate the planning action and monitor the planning to assure that the operational equipment is acquired synchronous with the requirements for trainer development (in many cases, 1-year cycle ahead of trainer peculiar equipment). For RDT&E trainers the funding for the operational equipment is programmed within the trainer funding line and involves the transfer of funds and a procurement agreement with the cognizant NAVSYSCOM program office. For OPN trainers operational equipment is funded outside of the trainer OPN line in a separate account managed within the NAVSYSCOM. In either case, the TDPH is responsible for the timely identification of the operational equipment requirements to permit the synchronous planning required.

Trainer Functional Baseline. Subsequent to the general guidance documented by the Trainer Requirement Baseline and prior to the preparation of trainer development specifications, the training agent is responsible for the development of the Trainer Functional Baseline document. The document will identify in detail the intended use of the trainer in terms of the training situation, training objectives, and functional training

TDPH  
Cognizant  
NAVSYSCOM  
Program  
Office

RDT&E  
(letter)  
OPN  
letter and  
CNET Form  
10170

Early dialogue between the TDPH and NAVSYSCOM is imperative to assure availability of the required operational equipment units.

Training  
Agent

Trainer  
Functional  
Baseline

capabilities that are required. The Trainer Functional Baseline once approved by the resource sponsor is considered direction to the TDPH and the charter of the FIP to maintain its integrity without unauthorized proliferation. The TDPH in many cases provides the training agent direct assistance in developing the trainer requirement baseline documentation.

Trainer Development Planning/Execution. The TDPH is responsible for all aspects of development planning, procurement, contractual testing, delivery, installation, and initial support. During the development phase of the trainer, the FPI functions in a supporting role to the TDPH as well as in a role, maintaining the integrity of the trainer functional base line. Specific development phase documentation of interest to the resource sponsor and the training agent are (1) an operational support plan, (2) a configuration management plan, (3) the installation plan, and (4) the test plan. All of the aforementioned plans involve an interrelationship with the training community. In addition to the above the training agent also has a requirement to provide some measure of support to the curriculum of which the trainer will become part. In some cases a complete curriculum development or update may be required. In all cases the training agent has established the requirement for an "Exercise Controllers Guide" per OD 45519.

Trainer Acceptability for Training. The TDPH is the Navy's agent responsible for the contractual acceptance of the trainer. Upon notification by the TDPH that the trainer has been contractually accepted and is certified as ready for training, the training agent is responsible to ascertain "Acceptability for Training." A Quality Assurance Revalidation (QASR) inspection is conducted

Various

TDPH

Training Agent  
QASR  
FPI

QASR Report  
FPI letter

Jointly with a FPT final evaluation. Subsequently the  
FPT will advise the resource sponsor via the training  
agent, addressing the acceptability of the trainer for  
its intended training use.

Technical Report 118

ANNEX C  
SURFACE WARFARE TRAINER GROUP (SWTG)

Surface Warfare  
Trainer  
Group  
(SWTG)

## SURFACE WARFARE TRAINER GROUP

1. Purpose. The purpose of this document is to identify the objectives of the SWTG; to develop basic guidelines for the conduct of SWTG activities; and to define the relationship of the SWTG to trainer Fleet Project Teams, Training Agent, Training Support Agent, Cognizant Commanders, and Functional Commanders responsible for the identification of requirements, development, procurement, installation and logistics support of all surface training devices and related training equipment.

2. Objectives. The major objectives of the SWTG are:

a. To ensure the timely identification of trainer needs consistent with the requirements of the Navy programming, planning, and budgeting system and the Navy training planning process.

b. In support of the 1st article training device RDT&EN (6.4) program, participate in the development of training approach alternatives to be documented in Development Proposals (DP) provided to CNO in response to Operational Requirements (OR). Evaluate surface warfare training program alternatives and select training/cost effective combination of training devices and operational equipment consistent with training needs and programming/budgetary constraints.

c. Coordinate surface warfare training device research and development programs with follow-on trainer requirements, and develop procedures for identification of all resources including development/procurement funding, GFE, MILCON, personnel, O&MN funds, etc.

d. Establish procedures for and accomplish necessary prioritization of first-article R&D trainer development projects, OPN-procured follow-on requirements, and major modification efforts to existing training devices.

e. Provide guidance and direction to CNET functional commands/activities on the development of training device and related training equipment POM submissions.

f. Provide a forum for trainer program review and for identification of problems in development, acquisition, acceptance, operational use, or support of training devices and related equipment. Develop alternative solutions and recommendations for decision by the DCNO (Surface Warfare).

g. To identify requirements and make recommendations to CNO concerning the establishment of Fleet Project Teams or other subcommittees as may be required to accomplish the objectives of the SWTG.

3. Guidelines

a. Membership. The SWTG includes representation from CNO, CNET, and most major commands and activities with significant interest/involvement in the surface warfare training device development program. Appendix A defines SWTG "Full-Membership" and the "Executive Committee Membership."

b. Subgroups. The fall meeting of the SWTG will consist of the full SWTG membership. Due to the diverse nature of Surface Warfare Training interests, and the difficulty of addressing these specific interests in a large-group setting, subgroups have been established to more efficiently utilize available time. Appendix B identifies the various subgroups, and designates chairmen. Appendix C provides a subgroup meeting schedule within the context of a one-week SWTG meeting. Program reviews, presentations, training issues, etc., unique to a specific warfare area will be addressed within the appropriate subgroup. A summary report of subgroup deliberations and a briefing of recommended action items originating within the subgroup, will be presented to the full membership by the subgroup chairman. Upon approval of the chair, recommended action items will become part of the SWTG minutes. It is anticipated that the subgroup participants will make maximum use of the subgroup as a deliberative body, and that the subgroup chairman will be brief in his presentation to the full membership.

c. Meetings. The meetings are co-chaired by the Chief of Naval Operations (Op-39) and the Chief of Naval Education and Training (N-94). CNET will normally convene meetings of the SWTG two times each year at the discretion of CNO. Additional meetings will be convened as required. To enhance the effectiveness of the body as a working group, these regular meetings of the SWTG will be called according to strict membership requirements as follows:

(1) November/December. Full membership meets for program review, including current POM status; identification of new issues/requirements; and development of the initial trainer requirements listing for the next POM submission (e.g., Fall '81 meeting will develop initial list of POM 85 requirements). The meeting will be conducted primarily in subgroups as defined in Appendix B, and according to the schedule provided in Appendix C.

(2) May/June. Executive Committee convenes to review preliminary training device POM documentation developed by NAVTRAEQUIPCEN in response to the requirements list developed at the November/December Meeting. To identify late-occurring requirements, and to finalize decisions on the resubmission of issues not supported in the previous POM. In addition, the executive members will approve the proposed training device modification program and prioritize all training device POM issues for submission to CNO. Functional commanders will commence training device-related RRR preparation for submission to CNET based upon previously supplied data and the POM documentation provided at this meeting.

Note: Membership identified in Appendix A is to be strictly observed, with member commands/activities limiting attendance to a minimum number of active participants with decision making authority.

d. Responsibilities

(1) CNO (Op-39). Serves as chairman of the SWTG. Approves the convening of all meetings of the SWTG. Upon establishment of the need for a meeting, and upon concurrence with a coordinated date for the meeting, CNO will request CNET to convene the SWTG.

(2) CNET (N-94). Serves as co-chairman, with CNO (Op-39), of the SWTG. Serves as Executive Secretary and chairs all combined business sessions of the SWTG. Maintains order, ensures execution of the meeting agenda and the preparation of necessary action items. Prepares and promulgates minutes of each meeting with pertinent action items. Tracks all SWTG action items and provide a status report to the membership at each meeting and between meetings as required. At an appropriate time consistent with this charter, and upon request from CNO (Op-39), CNET will convene the SWTG. Convening of the SWTG will be preceded by the following preparatory events:

- (a) Solicitation of issue papers/agenda items from the membership.
- (b) Preparation and promulgation of the meeting agenda.
- (c) Identification of the host activity.

(3) Host Activity. Upon identification of the host activity by CNET, promulgate specific data concerning meeting site, conference room locations for subgroups and combined sessions, room rates, BOQ availability, security clearance requirements, etc.

(4) Membership. Respond to CNET call for agenda items and issue papers. Limit number of participants to minimum required to adequately address agenda items and provide representation with appropriate decision making authority. Adequately prepare for and actively participate in appropriate deliberative bodies. Aggressively pursue the timely accomplishment of assigned action items and ensure notification of CNET (N-94) of all actions taken.

(5) Subgroup Chairmen. Responsible for preparation of the subgroup agenda in coordination with the entire subgroup membership; for promulgation of the agenda to the Executive Committee and the subgroup membership at least seven days prior to the meeting, and for efficient conduct of subgroup business sessions. Ensures preparation of subgroup minutes and written recommendations in the form of action items for presentation to the SWTG membership. The subgroup chairman when briefing each recommendation to the full-membership will indicate the subgroup vote count on the recommendation and a brief statement of the substance of dissent, if any. Based upon approval/acceptance of proposed actions by the co-chairmen, provides rough copies of minutes and action items to the Executive Secretary prior to the close of the meeting. Conducts continuing follow-up on action items originated by the Subgroup to ensure satisfactory completion. Invitation of command/activity representation other than that identified in Appendix B may be made by the subgroup chairman to address specific technical issues within the subgroup. The invitation will not extend to the full-membership meeting. Invitations will not be extended to contractor personnel without prior approval of the SWTG co-chairmen. Such intentions should be communicated to CNET (N-94) who will provide necessary coordination with CNO (Op-39) and advise the subgroup chairman of the CNO/CNET decision. Primary leadership of a subgroup will alternate between co-chairman on an annual basis, effective on 1 September of each year.

#### 4. Issue Paper/Action Item Format

a. All significant issues proposed by SWTG members for consideration by either the subgroups or the executive membership will be prepared utilizing the format of Appendix D. Issue papers should be one page in length and are submitted primarily for issues which will require action/decision by the group. Issue papers may also be presented as information on major issues which need to be brought to the attention of the SWTG. It is the responsibility of the originator of an issue paper to ensure receipt by the executive membership, and the appropriate subgroup chairman and membership, at least seven days prior to the SWTG meeting.

b. Action items assigned by the presiding SWTG chairman will be documented utilizing the format of Appendix E. Subgroup chairmen will utilize the same format for documenting proposed action items arising from subgroup deliberations. Forms will be provided by the host activity at each SWTG meeting. Action items will be numbered by CNET prior to distribution of the minutes. Items will be sequentially numbered throughout a calendar year.

Appendix A

SWG Membership

Executive Committee:

CNO (Op-39)  
CNET (N-94)  
COMNAVSURFLANT (N6)  
COMNAVSURFPAC (N6)  
CNTECHTRA (N3)  
COMTRALANT (01)  
COMTRAPAC (01)  
CHNAVMAT (MAT 042)  
CO, NAVTRAEQUIPCEN (N81S)

Full Membership:

Executive Committee  
COMNAVSEASYSOM (SEA 05L1, SEA 06)  
COMNAVELEXSYSOM  
CNAVRES  
CHNAVMAT (PM-4)  
CO, FLECOMBATRACENPAC  
CO, FLECOMBATRACENLANT  
CO, FLEASWTRACENPAC  
CO, FLEASWTRACENLANT  
CO, FLETRACEN, Norfolk  
CO, FLETRACEN, San Diego  
CO, FLETRACEN, Mayport  
COMFLETRAGRU, Pearl Harbor  
COMFLETRAGRU, Yokosuka  
CO, FLEMINWARTRACEN, Charleston  
CO, NAVPHIBSCOL, Coronado  
CO, NAVPHIBSCOL, Little Creek  
CO, FLETRAU, Little Creek  
CO, FLTCOMBATSYSYTRAUPAC, San Diego  
CO, SWOSCOLCOM, Newport  
CO, SERVSCOLCOM, Great Lakes  
CO, NAVTECHTRACEN, Corry Station  
CO, TACTRAGRULANT  
CO, TACTRAGRUPAC  
COMFEWSG

Appendix B

SWG Subgroups

1. Subgroup Identification

a. ASW Subgroup

FLEASWTRACENPAC, Co-chairman  
FLEASWTRACENLANT, Co-chairman  
CNO (Op-39 Action Officer)  
CNET (N-948)  
FLECOMBATRACENLANT  
FLECOMBATRACENPAC  
PM-4  
LAMPS MKIII FIT  
COMFLETRAGRU, Pearl Harbor  
FLETRAU, Little Creek  
FLTCOMBATSYSTRAUPAC, San Diego  
FLEMINWARTRACEN, Charleston  
COMTRALANT  
COMTRAPAC  
CNTECHTRA  
COMNAVSURFLANT  
COMNAVSURFPAC  
COMNAVSEASYSKOM  
NAVTRAEQUIPCEN  
Other commands/activities as determined by subgroup chairman

Note: Includes all surface ASW trainers.

b. Combat Systems/Pierside Subgroup

FLECOMBATRACENLANT, Co-chairman  
FLECOMBATRACENPAC, Co-chairman  
CNO (Op-39 Action Officer)  
CNET (N-946)  
FLETRAU, Little Creek  
FLTCOMBATSYSTRAUPAC  
COMTRALANT  
COMTRAPAC  
CNTECHTRA  
COMNAVSURFLANT  
COMNAVSURFPAC  
COMNAVSEASYSKOM  
NAVTRAEQUIPCEN  
Other commands/activities as determined by subgroup chairman

Note: Includes AAW/SUW, Pierside, and organic trainers.

c. Engineering/Propulsion/Shiphandling Subgroup

SWOSCOLCOM, Co-chairman  
SERVSCOLCOM, Great Lakes, Co-chairman  
CNO (Op-39 Action Officer)  
CNET (N-947)  
FLETRACEN, San Diego  
FLETRACEN, Norfolk  
FLETRACEN, Mayport  
FLETRAGRU, Pearl Harbor  
FLETRAGRU, Yokosuka  
COMTRALANT  
COMTRAPAC  
CNTECHTRA  
COMNAVSURFLANT  
COMNAVSURFPAC  
COMNAVSEASYSKOM  
NAVTRAEQUIPCEN  
Other commands/activities as determined by subgroup chairman

Note: Includes Damage Control, Seamanship, and Firefighting trainers

d. Electronic Warfare/C<sup>3</sup> Subgroup

FLECOMBATRACENPAC, Co-chairman  
NAVTECHTRACEN, Corry, Co-chairman  
CNO (Op-39 Action Officer)  
CNET (N-944)  
FLECOMBATRACENLANT  
FLETRAGRU, Pearl Harbor  
TACTRAGRULANT  
TACTRAGRUPAC  
FEWSG  
COMTRALANT  
COMTRAPAC  
CNTECHTRA  
COMNAVSURFLANT  
COMNAVSURFPAC  
COMNAVELEXSYSKOM  
NAVTRAEQUIPCEN  
Other commands/activities as determined by subgroup chairman

Note: Includes Cryptologic and tactics trainers

e. Amphib/Mine Warfare Subgroup

FLEMINWARTRACEN, Charleston, Co-chairman  
NAVPHIBSCOL, Coronado, Co-chairman  
CNO (Op-39 Action Officer)  
CNET (N-94)  
NAVPHIBSCOL, Little Creek  
COMTRALANT  
COMTRAPAC  
CNTECHTRA  
COMNAVSURFLANT  
COMNAVSURFPAC  
COMNAVSEASYSKOM  
NAVTRAEQUIPCEN  
Other commands/activities as determined by subgroup chairman

Note: Includes Special Warfare and NGFS.

f. Reserve Subgroup

CNAVRES, Chairman

CNET (N-946)

CNO (Op-39), Reserve Affairs Action Officer

CNET (019)

NAVTRAEQUIPCEN

Other commands/activities as determined by subgroup chairman

Note: Addresses all Surface Warfare Reserve trainer issues

Appendix C

Surface Warfare Trainer Group

Fall Meeting Schedule

	0800	1200	1300	1700
M O N	← Anti-submarine Warfare Subgroup →			
T U E	← Combat Systems/Pierside Subgroup →			
	← ENG/PROP Subgroup →		← RESERVE Subgroup →	
W E D	← EW/C3 Subgroup →		← Full-membership meeting →	
	← AMPHIB/MINE Subgroup →		(General issues/presentations)	
T H U R	← Full-membership Meeting →			
	(ASW, Combat Systems, and EW Subgroup reports)		(ENG, AMPHIB, and RESERVE Subgroup reports)	
F R I	← Full-membership Meeting →			

Appendix D

Issue Paper Format

TITLE

- OBJECTIVES:** State the general training objectives to be accomplished.
- BACKGROUND:** State the problem that makes the issue important. Give a brief background on how the problem occurred.
- DISCUSSION:** Give a brief synopsis showing views of SWTG members if known. Present alternatives with pros and cons and provide funding estimates. Draw necessary conclusions from the presented data.
- RECOMMENDATIONS:** Originator's recommended approach to resolving the issue.
- ACTION/DECISION:** Be specific in identifying the actions or decisions requested of the SWTG. If the paper is strictly informational, then so state.

**NOTE:** Issue papers for consideration by the SWTG are to be provided to the executive membership, and to appropriate subgroup membership, seven days prior to meeting.

Appendix E

SWG DISCUSSION/ACTION ITEM

TITLE:

DISCUSSION:

ACTION:

LEAD ACTIVITY:  
ASSIST ACTIVITY:  
RESULTS TO:  
DUE DATE:

Technical Report 118

ANNEX D

MATRIX OF TRAINING DEVICE ACQUISITION MANAGEMENT SYSTEM  
REFERENCE DOCUMENTS AND APPLICATION AREA(S)

## Technical Report 118

The matrix included in this appendix lists the primary reference documents considered in developing a management system for first article (prototype) surface and subsurface training device acquisition programs. This matrix indicates, for each reference document, the primary area(s) to which the document applies. It should be noted that the specific area of application may not be included in the reference document, only the concept for the area. To illustrate, the Training Operational Requirement (TOR) is not included in OPNAVINST 5000.42A. However, the Operational Requirement (OR), from which the TOR is derived, is included in OPNAVINST 5000.42A. Similar rationale applies to the other areas of application included in the matrix.

A complete citation for each reference document is included in the listing at the end of this annex.

For reader convenience, the acronyms and abbreviations used in the reference document matrix are defined below:

TRS	Training Requirement Statement
TRNA	Training Requirement Need Analysis
TOR	Training Operational Requirement
TDAP	Training Decision Alternatives Proposal
TETEP	Training Equipment Test and Evaluation Plan
ATA	Approval for Training Acceptance
CNET	Chief of Naval Education and Training
FPT	Fleet Project Team
NAVTRAEQUIPCEN/ NTEC	Naval Training Equipment Center
SWG	Surface Warfare Trainer Group
STWG	Submarine Trainer Working Group

W1171 RDT&E Appendix D/WRT

RDT&E	Research, Development, Test and Evaluation
NTP	Navy Training Plan
T&E	Test and Evaluation
TAEG	Training Analysis and Evaluation Group
TEE	Training Effectiveness Evaluation
OR	Operational Requirement
NDCP	Navy Decision Coordinating Paper
TEMP	Test and Evaluation Master Plan
INST	Instruction
MEMO	Memorandum
ltr	Letter
NAVCOMPT	Navy Comptroller
NAVMAT	Naval Material

Technical Report 118

REFERENCE DOCUMENT	AREA(S) OF APPLICATION												
	TRS	TRNA	TOR	TDAP	TETEP	ATA	CNET	FPT	NTEC	SWTG/STWG	RDT&E	NTP	T&E
DEPARTMENT OF DEFENSE													
5000.1											X		
5000.2	X	X	X	X	X								
5000.3					X								X
SECRETARY OF THE NAVY													
INST 5000.1A											X		
INST 9089.1											X		
OPNAV (CNO)													
ltr 992F2/640753, 29 Mar 76	X						X						
MEMO 901/582126, 14 Mar 78											X		
MEMO 987/644701, 11 Apr 80			X										
MEMO 987/140521, 30 Dec 77					X								X
MEMO 991B/644005, 10 Jan 78					X								X
MEMO 39C/18, 13 Jan 78					X								X
OP-01 Guide, (draft) 3 Jun 81	X	X	X	X	X								X
INST 1500.8H	X											X	
INST 1551.7B								X					
INST 3960.10					X								X
INST 4720.9D						X							
INST 5000.42A	X		X	X	X								X
INST 5000.46					X								X
INST 5450.176A											X		
INST 5450.194							X						
INST 10171.5					X								
NOTICE 5000					X						X		

Technical Report 118

REFERENCE DOCUMENT	AREA(S) OF APPLICATION												
	TRS	TRNA	TOR	TDAP	TETEP	ATA	CNET	FPT	NTEC	SWG/STWG	RDT&E	NTP	T&E
NAVCOMPT													
Manual 073002							X						
Manual 075148							X						
MEMO NCB 521, 14 Dec 77							X			X			
CNET													
ltr N-34A, 6 Nov 79					X								X
ltr N-945, 15 Apr 81							X			X			
ltr N-611, 11 Sep 81							X						
ltr N-10A3, 21 Jul 81					X								
Command Inspection Report							X						
Guidelines-STWG	X	X	X	X	X			X	X	X			
Guidelines-SWTG	X							X	X	X			
MEMO N-5, 10 Feb 78													X
INST 1500.9												X	
INST 1500.12							X						
INST 3920.1	X		X										
INST 3920.1B	X		X										
INST 5450.8									X				
INST 5450.31A									X				
INST 7000.2A	X										X		
INST 7000.2B	X	X	X	X	X					X			
INST 11102.1					X								
SUPPORT INST 1551.5A	X												

Technical Report 118

REFERENCE DOCUMENT	AREA(S) OF APPLICATION												
	TRS	TRNA	TOR	TDAP	TETEP	ATA	CWET	FPT	NTEC	SWTG/STWG	RDT&E	NTP	T&E
NAVMAT													
INST 1500.12	X												
INST 3900.11A										X			
INST 3910.7B	X												
INST 3910.13A	X												
INST 3960.6A					X								X
INST 4720.1						X							
INST 5450.28									X				
NOTICE 5000										X			
OFFICE OF NAVAL RESEARCH													
INST 3910.5										X			
TAEG													
ltr W1160, 22 Oct 81													X
Procedures for TEE					X								X
Report No. 46 (Moore, 1977)	X		X	X	X								
Report No. 71 (Cordell, Nutter & Heidt, 1979)					X	X							X
NAVTRAEQUIPCEN													
ltr N-8/121, 28 Feb 80.					X								X
INST 1551.7B								X	X				
INST 3900.10C									X				
INST 3910.4A					X				X				
INST 3930.6F					X				X				
INST 3930.10D, 16A, 18B					X				X				
INST 4280.2C					X				X				



Technical Report 118

REFERENCE DOCUMENTS

Listed below are the principal references used in preparing this study. Consult NAVPUBNOTE 5215 or the Department of Defense (DOD) Directives System for current version of DOD and Department of the Navy directives and instructions.

CNET

- ltr N-5, Test and Evaluation Procedures for Training Devices, 21 Sep 1979.
- CNET Command Inspection Report; Tab C-5, Training Device Development and Procurement, 1981.
- ltr N-611, CNET Command Inspection Report; Tab C-5, Training Device Development and Procurement, 11 Sep 1981.
- Guidelines N-945, Submarine Trainer Working Group, 26 Nov 1980.
- Guidelines N-945, Surface Warfare Trainer Group (undated).
- ltr N-945, Draft SECNAV/OPNAV Instructions on Selection of Training Equipment; comments concerning, 15 Apr 1981.
- INST 1500.9, Participation by the Naval Education and Training Command in the Preparation and Implementation of Navy Training Plans, 26 Jun 1974.
- INST 1500.12, Glossary of Navy Education and Training Terminology, 14 Sep 1976.
- SUPPORT INST 1551.5A, Training Situation Analyses (TSA); Procedures for Conducting, 3 Jan 1978.
- INST 3920.1, Research, Development, Test and Evaluation and Studies Program of the Naval Education and Training Command, 25 Sep 1974.
- INST 3920.1B, Research, Development, Test and Evaluation Program of the Naval Education and Training Command, 26 Aug 1981.
- INST 5450.8 (NAVMAT INST 5450.28), Additional Duty Functions of the Commanding Officer, NAVTRAEQUIPCEN, Orlando, Florida to CHNAVMAT and Relationship Between NAVTRAEQUIPCEN and Systems Commanders, Project Managers, 14 Dec 1972.
- INST 5450.31A, Naval Training Equipment Center, Orlando, Florida; mission and functions, 3 Nov 1980.

Technical Report 118

REFERENCE DOCUMENTS (continued)

- INST 7000.2A, Procedures and Responsibilities for the Development of the Program Objective Memorandum (POM) Documentation for the CNET Training Device Program, 22 Jun 1979.
- INST 7000.2B, Policy, Procedures, and Responsibilities for the Planning and Resource Requirement Identification for Surface and Subsurface Training Devices, 24 Nov 1981.
- INST 11102.1, Technical Training Equipment (TTE) and Training Devices Installation Planning and Management Responsibilities, 21 Aug 1981.
- ltr N-10A3, Training Equipment Installation Facility Requirements, 21 Jul 1981.
- MEMO N-5, Test and Evaluation of Training Devices, 10 Feb 1978.

DEPARTMENT OF DEFENSE

- DIRECTIVE 5000.1, Major System Acquisitions, 18 Jan 1977.
- DIRECTIVE 5000.2, Major System Acquisition Process, 18 Jan 1977.
- DIRECTIVE 5000.3, Test and Evaluation, 11 Apr 1978.

NAVCOMPT

- Manual 075148, Training and Instruction of Military Personnel.
- Memo NCB 521, Requirement for Budgeting Procurement of First Item Training Devices in RDT&EN, 14 Dec 1977.
- Manual 073002, Procedures for Establishing Availability: Department of the Navy Fund Flow Chart.

NAVMAT

- INST 1500.12, Technical Training Equipment Acquisition Requirements, 6 Apr 1981.
- INST 3900.11A, Independent Research and Development (IR&D) Program, 21 Feb 1974.

Technical Report 118

REFERENCE DOCUMENTS (continued)

- INST 3910.7B, Planning Procedures for the Department of the Navy Exploratory Development Program, 3 Oct 1974/with CH-1 & 2.
- INST 3910.13A, Policy and Procedures Governing Systems Command/Laboratory Management of Exploratory Development, 23 Oct 1969.
- INST 3960.6A, Test and Evaluation, 3 May 1976.
- INST 4720.1, Approval of Systems and Equipments for Service Use (ASU), 13 Dec 1974.
- NOTICE 5000, Defense Acquisition Regulatory System, 9 Jun 1978.
- INST 5450.28 (CNET INST 5450.8), Additional Duty Functions of the Commanding Officer, NAVTRAEQUIPCEN, Orlando, Florida to CHNAVMAT and Relationship Between NAVTRAEQUIPCEN and Systems Commanders, Project Managers, 14 Dec 1972.

NAVTRAEQUIPCEN

- ltr N-8/121, Test and Evaluation Procedures for Training Devices (Draft CNET INSTRUCTION 3960. Test and Evaluation Procedures for RDT&E Training Device Development), 28 Feb 1980.
- INST 1551.7B, Fleet Participation in Development, Acquisition, and Acceptance of Major Training Devices, 18 Jun 1974.
- INST 3900.10C, The Naval Training Equipment Center Planning and Programming System; Establishment of, 29 Aug 1977.
- INST 3910.4A, Functional Statement, Functional Description, Mini-Military Characteristics, and Detail Military Characteristics; Instructions and Responsibilities for, 18 Feb 1977.
- INST 3930.6F, Policy and Procedures for Initiation and Control of Technical Program Tasks (Acquisition and Research) and Program Control Action Documents, 15 Aug 1975.
- INST 3930.10D, Identification of Program Control Documents, 8 Jun 1976.
- INST 4280.2C, Acquisition Planning, 24 Nov 1980.
- INST 4720.1G, Field Requests for Changes to Training Devices and Simulators Under Cognizance of the NAVTRAEQUIPCEN (Cognizance Symbol "20"); Procedures and Information Concerning, 4 Aug 1976.

Technical Report 118

REFERENCE DOCUMENTS (continued)

INST 5200.2A, Acquisition Management Systems Control, 5 Mar 1974.

NOTICE 5400, Functional Realignment Between the Engineering Department, N-2, and the Logistics Department, N-4, 30 Jun 1980.

OFFICE OF NAVAL RESEARCH

INST 3910.5, Research and Development Planning Summary (DD Form 1634) for Research and Development Program Planning Review, 10 Mar 1969.

OPNAV (CNO)

Memo 901/582126, Programming Guidance for the Acquisition of Training Devices, 14 Mar 1978.

Memo 987/644701, Operational Requirement (OR's) for Manpower, Personnel and Training (MPT) 6.3 and 6.4 Projects, 11 Apr 1980.

INST 1500.8H, Preparation and Implementation of Navy Training Plans (NTPs) in Support of Hardware and Non-hardware Oriented Development, 3 Jul 1975.

INST 1551.7B, Fleet Participation in Development, Acquisition, and Acceptance of Major Training Devices, 22 Apr 1977.

INST 3960.10, Test and Evaluation, 22 Oct 1975.

INST 4720.9D, Approval of Systems and Equipments for Service Use, 23 Aug 1974.

NOTICE 5000, Reduced Documentation Requirements for the Acquisition Process, 9 Jun 1981.

INST 5000.42A, Weapon Systems Selection and Planning, 3 Mar 1976.

INST 5000.46, Decision Coordinating Papers (DCPs), Program Memoranda (PMs) and Navy Decision Coordinating Papers (NDCPs); Preparation and Processing of, 10 Mar 1976.

INST 5450.176A, Chief of Naval Material; Mission and Functions of

INST 5450.194, Chief of Naval Education and Training; Mission and Functions, 16 Feb 1977.

Technical Report 118

REFERENCE DOCUMENTS (continued)

INST 10171.5, Certification of Major Aviation Training Devices, 9 Nov 1976 with CH-1.

MEMO 987/140521, Independent Evaluation of Training Devices, 30 Dec 1977.

MEMO 991B/644005, Operational Test and Evaluation of Training Devices, 10 Jan 1978.

MEMO 39C/18, Evaluation of Training Devices, 13 Jan 1978.

Guide, Management of Manpower, Personnel and Training Research, Development, Studies, and Surveys (draft), 3 Jun 1981.

SECRETARY OF THE NAVY

INST 5000.1A, System Acquisition in the Department of the Navy.

INST 9089.1, Selection of Trainers/Training Devices, 9 Jun 1980.

NAVY PERSONNEL RESEARCH AND DEVELOPMENT CENTER

Sands, F. F. and Glaser, E. M. (Ed.) Proceedings of the 1977 National Symposium of the Military Services on Utilization of People-Related Research, Development, Test and Evaluation (RDT&E). NPRDC SR 78-3, January 1978. Navy Personnel Research and Development Center, San Diego, CA 92152

TAEG

Description of Procedures for Conducting Training Effectiveness Evaluations of Training Devices (draft), Feb 1980.

Cordell, C. C., Nutter, R. V., and Heidt, E. A. Proposed OPNAV Instruction for Test and Evaluation of Navy Training Devices Procured Under RDT&E Funding. TAEG Report No. 71, June 1979. Training Analysis and Evaluation Group, Orlando, FL 32813. (AD A073402)

Moore, E. O. The Management of Defense System and Equipment Training: A Guide for the Naval Education and Training Command. TAEG Report No. 46, July 1977. Training Analysis and Evaluation Group, Orlando, FL 32813. (AD A046025)

Smode, A. F. and Hall, E. R. "Translating Information Requirements into Training Device Fidelity Requirements." In R. N. Hale, R. A. McKnight, and J. R. Moss (Ed.) Proceedings Human Factors Society 19th Annual Meeting, October 1975, Dallas, TX.

Technical Report 118

REFERENCE DOCUMENTS (continued)

OTHER

Operational Requirement (OR); Advanced Fire Fighting Simulator (PN-51),  
20 Jul 1976.

Navy Decision Coordinating Paper (NDCP): Advanced and Synthetic Fire Fighting  
Simulators, 12 Sep 1977.

Required Tests and Measurements Derived from NDCP and Other Documents: Advanced  
Fire Fighting Simulator, 3 Oct 1978.

Test and Evaluation Master Plan (TEMP): Advanced Fire Fighting Simulator  
(draft).

Audit Report 1400058, Service-wide Audit of the Aircraft Flight Simulator  
Program, 4 Jan 1980.

NAVSO P-2457 (Rev. 12-79), Department of the Navy RDT&E Management Guide,  
15 Dec 1979.

Technical Report 118

DISTRIBUTION LIST

Navy

OASN (R&D, MRA&L)  
CNO (OP-115, OP-987H, OP-987, OP-12, OP-29, OP-39, OP-59, OP-983)  
NAVCOMPT (NCD-7)  
ONR (458 (2 copies), 455)  
CNM (MAT-08T2, MAT-04)  
CNET (01, 02, N-5, N-94)  
CNAVRES (02)  
COMNAVSEASYSKOM (05L1C, 05L1C2)  
COMNAVAIRSYSKOM (03, 340F, 413G)  
CNTECHTRA (016 (5 copies), N-6)  
CNATRA (Library)  
COMTRALANT  
COMTRALANT (Educational Advisor)  
COMTRAPAC (2 copies)  
CO NAVPERSRANDCEN (Library (4 copies))  
NAVPERSRANDCEN Liaison (021)  
Superintendent NAVPGSCOL (2124, 32)  
Superintendent Naval Academy Annapolis (Chairman, Behavioral Science Dept.)  
CO NAVEDTRAPRODEVCOM (AH3, EAT, Technical Library (2 copies))  
CO NAVEDTRASUPPCENLANT (N-3 (2 copies))  
CO NAVEDTRASUPPCENPAC (5 copies)  
CO FLECOMBATRACENPAC  
CO NAMTRAGRU  
CO NAVTECHTRACEN Corry Station (101B, 3330, Cryptologic Training Department)  
CO NAVTRAEQUIPCEN (TIC (2 copies), N-001, N-002, N-09, N-7)  
Center for Naval Analyses (2 copies)  
U.S. Naval Institute  
OIC NODAC (2)  
CO TRITRAFAC (2 copies)  
CO NAVSUBTRACENPAC (2 copies)  
CO FLEASWTRACENPAC  
CO FLETRACEN SDIEGO  
Executive Director NAVINSTPRODEVDET  
CO NAVSUBSCOL NLON (Code 0110)  
CO NAVTECHTRACEN Treasure Island (Technical Library)  
TAEG Liaison, CNET 022 (5 copies)  
NAVEDTRAPRODEVCOMDET Memphis  
CO NAVAVSCOLSCOM (Code 40C)  
CO NAVTECHTRACEN Meridian  
COMFLETRAGRU Pearl Harbor  
NAVEDTRAPRODEVCOMDET Meridian  
COMNTC Orlando

Air Force

Headquarters, Air Training Command (XPTD, XPTIA) Randolph Air Force Base

Technical Report 118

DISTRIBUTION LIST (continued)

Air Force (continued)

Air Force Human Resources Laboratory, Brooks Air Force Base  
Air Force Human Resources Laboratory (Library), Lowry Air Force Base  
Air Force Office of Scientific Research/AR  
Headquarters Tactical Air Command (DOOS) Langley Air Force Base  
AFMTC/XR Lackland Air Force Base

Army

Commandant, TRADOC (Technical Library)  
ARI (PERI-RH, PERI-SZ, PERI-SM, PERI-IC)  
ARI Field Unit - Fort Leavenworth  
ARI (Reference Service)  
ARI Field Unit - Fort Knox (PERI-IK)  
COM USA Armament Materiel Readiness Command (DRSAR-MAS)

Coast Guard

Commandant, Coast Guard Headquarters (G-P-1/2/42, GRT/54)

Marine Corps

CMC (OT)  
CGMCDEC  
Director, Marine Corps Institute  
CO MARCORCOMMELECSOL

Other

Military Assistant for Human Resources, OUSDR&E, Pentagon  
Program Manager, Office of Cybernetics Technology, Defense Advanced Research  
Projects Agency  
Institute for Defense Analyses  
COM National Cryptologic School (Code E-2)  
Director, Center for Educational Technology, FSU

Information Exchanges

DTIC (12 copies)  
DLSIE  
Executive Editor, Psychological Abstracts, American Psychological Association  
ERIC Processing and Reference Facility, Bethesda, MD (2 copies)