

AD-A115 829

CACI INC-FEDERAL ARLINGTON VA  
PROGRAMMER'S MANUAL FOR THE FORECAST 90 COMPUTER PROGRAMS.(U)  
1975 R E HAYES

F/6 9/2

DAAG39-75-C-0106

UNCLASSIFIED

NL

| OF |  
414  
1 5829

END  
DATE  
FILMED  
07-82  
DTIC

AD A115829



**DISTRIBUTION STATEMENT A**  
Approved for public release;  
Distribution Unlimited



11

FINAL TECHNICAL REPORT

PROGRAMMER'S MANUAL FOR THE  
FORECAST 90 COMPUTER PROGRAMS

~~RESTRICTED FOR PUBLIC RELEASE~~  
DISTRIBUTION UNLIMITED

Sponsored by:  
Department of the Army  
Harry Diamond Laboratories

OTIC  
ECTE  
JUN 21 1982  
D

Contract Number	DAAG39-75-C-0106
Program Code Number	W74G3D
Contractor	CACI, Inc.-Federal 1815 North Fort Myer Drive Arlington, Virginia 22209
Effective Date of Contract	November 7, 1974
Expiration Date of Contract	November 7, 1975
Amount of Contract	\$224,205
Principal Investigator	Dr. Richard E. Hayes

The views and conclusions contained in this document are those of the authors and should not be interpreted as necessarily representing the official policies, either expressed or implied, of the Army, Defense Advanced Research Projects Agency, or the U.S. Government.

DISTRIBUTION STATEMENT A  
Approved for public release;  
Distribution Unlimited

→ Programs & procedures included

TABLE OF CONTENTS

	<u>Page</u>
PREFACE.....	iv
INTRODUCTION.....	1
GENERAL INFORMATION ON THE FORECAST 90 PROGRAMS.....	10
NET1: > A Network Display Program.....	12
NET2: < A Batch Mode Equivalence Search Program.....	24
NET3: < An Interactive Equivalence Search Program.....	29
NET4: < A Network Summary Program.....	33
GLOSSARY OF TERMS FOR THE NET PROGRAMS.....	38
APPENDIX I: Annotated NET1 Listing	
APPENDIX II: Annotated NET2 Listing	
APPENDIX III: Annotated NET3 Listing	
APPENDIX IV: Annotated NET4 Listing	
APPENDIX V: Listing of FORECAST 90 Files	

Accession For	
NTIS GRA&I	<input checked="" type="checkbox"/>
DTIC TAB	<input type="checkbox"/>
Unannounced	<input type="checkbox"/>
Justification	
By	
Distribution/	
Availability Codes	
Avail and/or	
Dist	Special



---

LIST OF TABLES

---

	<u>Page</u>
Table 1. Sample Code Designations.....	5
Table 2. Summary of FORECAST 90 Programs.....	11
Table 3. Sample of the NET1 Input: A Portion of One of the Tree Files.....	22
Table 4. Definitions of the NET1 Variables.....	23
Table 5. Sample Listing of the Node Information File (NIF)...	26
Table 6. Definitions of the NET2 Variables.....	28
Table 7. Definitions of the NET3 Variables.....	32
Table 8. Sample Listing of the Tree Summary File (TSF).....	34
Table 9. Definitions of the NET4 Variables.....	35

---

LIST OF FIGURES

---

	<u>Page</u>
Figure 1. The Structure of the FORECAST 90 Networks.....	2
Figure 2. An Example of the Network Coding System from Trend to Decisional Outcome.....	4
Figure 3. Two Distinct Networks with Potential Cross-Over Points.....	8
Figure 4. Two Integrated Networks.....	9
Figure 5. Schematic Diagram of a Very Simple Decision Tree.	13
Figure 6. NET1 - Main Program.....	16
Figure 7. NET1: Subroutine SF (LLX, NEV, NODE, LS).....	17
Figure 8. NET1: Subroutine SB.....	18
Figure 9. NET1: Subroutine SR.....	19
Figure 10. NET1: Subroutine Child.....	20
Figure 11. NET1: Subroutine Print.....	21
Figure 12. Program NET2.....	27
Figure 13a. NET3: Section 1: Read User's Selection Code...	30
Figure 13b. NET3: Section II: Search Node Information (NIF) for Matches to Selection Code.....	31
Figure 14a. Program NET4: Option "MOD," "END," "STOP," "HELP," "ALL," and "ADD".....	36
Figure 14b. Program NET4: Display Option.....	37

---

## PREFACE

---

Three manuals have been written for the FORECAST 90 Project, a contract jointly funded by the Army and the Defense Advanced Research Projects Agency.

- "A Guide to Network Construction and Utilization"
- "User's Manual for the FORECAST 90 Computer Programs"
- "Programmer's Manual for the FORECAST 90 Computer Programs"

These manuals show how to construct and use networks, how to use the computer programs written for the project, and how to maintain the FORECAST 90 computer programs.

A large number of individuals have contributed significantly to the FORECAST 90 Project. Special mention must be given to Colonel John G. Pappageorge, the project monitor at the Strategic Studies Institute, who formulated the initial concept of FORECAST 90 and followed it through the contract phase with uncommon dedication, insight, and patience. The entire research effort is appreciably better as a result of his many comments, criticisms, and suggestions. Colonel Joseph Pizzi, the Director of the Strategic Studies Institute and Chairman of the Study Advisory Group (SAG), provided assistance and guidance at critical points in the project. Members of and observers to the SAG participated heavily in the research, often raising fundamental questions about the project, and always contributing to a better product. Captain Daryl Steiner and Lieutenant Ron Parker of the ADP Support Group at Carlisle Barracks spent many long hours unraveling the undocumented intricacies of the U.S. Army War College computer system.

CACI's support staff edited and typed draft after draft of the three manuals with unfailing good humor. Particular thanks are due to Carol Franco,

who converted dangling participles and split infinitives into more readable prose, and Sharon O'Rourke, who always found some new way to juggle work loads so that one more part of the three manuals could be completed. Ann Yamat cheerfully typed most of the drafts, with considerable assistance at critical points from Nancy Streeter. We owe a substantial debt of gratitude to each of these individuals.

---

## INTRODUCTION

---

CACI, Inc., has written and placed 52 networks in computer storage at the U.S. Army War College (USAWC) as part of the Strategic Studies Institute's FORECAST 90 effort. This manual presents a brief overview of the structure and coding of the 52 FORECAST 90 networks, (which are described in greater detail in "A Guide to Network Construction and Utilization"), and provides documentation for the FORECAST 90 computer programs.

### WHAT ARE THE FORECAST 90 NETWORKS?

The 52 FORECAST 90 networks are a way of looking at the subsequents, or downstream effects, of an action that might occur today. Thus, they provide a means to assess the implications of various policy options that might be taken in response to an event that is significant enough to affect existing relationships between countries. These disruptive events are called "catalytic events" in the FORECAST 90 system, and each FORECAST 90 network is built on the occurrence of a specific catalytic event.

Figure 1 presents an example of the structure of the FORECAST 90 networks. Each network fits this form because each is built on a trend, a determining factor, a catalytic event, five affected activities, one or more first-, second-, and third-order effects, and a series of decisional outcomes. The nets are developed to examine a catalytic event on a major ongoing trend in world affairs (e.g., detente) for five affected activities-- U.S./USSR relations, U.S./PRC relations, U.S./Japanese relations, U.S./Western European relations, and U.S./other country relations. The impact of the catalytic event on the trend in each of these five affected activities is filtered through one or more first-, second-, and third-order effects (that is, attempts to develop plausible responses that the major countries involved in the catalytic event or affected by it might attempt to take). The impact of the entire sequence displayed in Figure 1 is

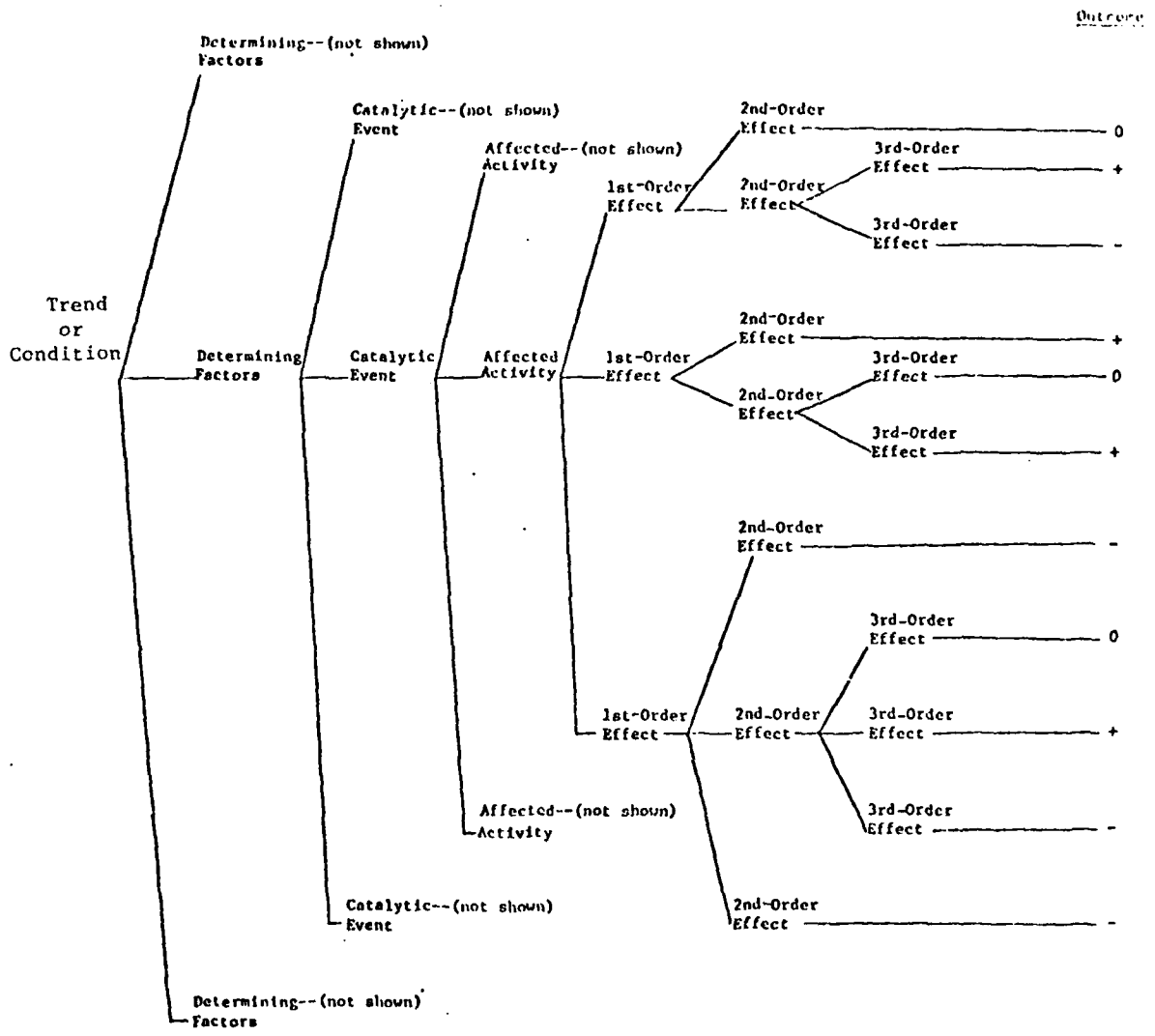

Figure 1. The Structure of the FORECAST 90 Networks.

then summarized in the decisional outcome column where the trend under examination can be increased, decreased, or maintained.

Five different trend areas--economic, military, political, socio-economic and technological--have been used to construct the networks. Regardless of the trend involved, all networks have the same structure.

#### CODING THE NETWORKS

Each distinct point in a network is called a node, and each node is coded with a unique alphabetic and numeric combination. While the structure of the networks and the structure of the codes are consistent across all of the networks, each node in each network is uniquely numbered. Figure 2 attempts to illustrate these points by displaying the structure of the code for the nodes for a hypothetical political tree.

The code for each network begins with a letter designating whether it is an economic (E), military (M), political (P), socio-psychological (S), or technological (T) tree. Once the subject area of the network is designated, two digits are added to the code for the determining factor. Two additional digits are added for the catalytic event. One digit each is added for the affected activities, the first-, second-, and third-order effects. The network code ends with a unique one-letter and three-digit designation for each decisional outcome. Using the information given in Figure 2, the node numbers for each point in the network can be written as in Table 1.

Three characteristics of the coding system should be noted. First, each network is stored in the USAWC computer system under the number of its catalytic event. Hence, to reference a computer-stored network, the user must know the number of its catalytic event. For easy reference, the network number and the catalytic event for each network are listed, by category of subject matter, in Appendix I of the "User's Manual for the

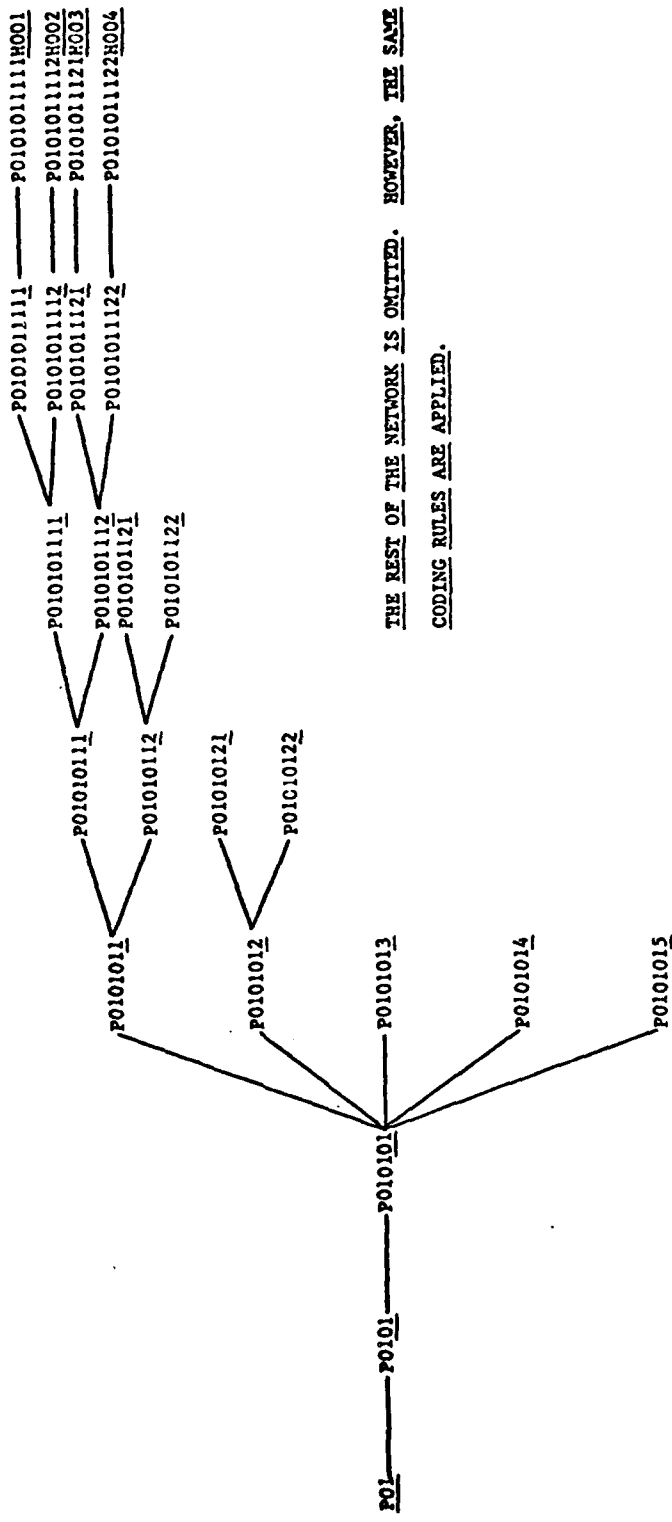

THE REST OF THE NETWORK IS OMITTED. HOWEVER, THE SAME CODING RULES ARE APPLIED.

Trend	Determining Factors	Catalytic Events	Affected Activities	First-Order Effects	Second-Order Effects	Third-Order Effects	Decisional Outcomes

Figure 2. An Example of the Network Coding System from Trend to Decisional Outcomes.

TABLE 1  
Sample Code Designations

<u>Level of the Tree</u>	<u>Full Node Designation</u>
Trend	P01.
Determining Factors	P0101.
Catalytic Event	P010101.
Affected Activities	P0101011.
First-order Effects	P01010111. P01010112.
Second-order Effects	P010101111. P010101112.
Third-order Effects	P0101011111. P0101011112.
Decisional Outcome	P0101011111.H001 P0101011111.H002

FORECAST 90 Computer Programs."<sup>1</sup> Thus, should any potential user of the FORECAST 90 nets ever need to know the number of a specific network, Appendix I of that manual gives the information.

Second, each network employs a standard referencing procedure for the five affected activities on which the networks are focused. These codes, as noted in Figure 2, are standardized as follows:

- U.S./USSR relations = 1
- U.S./PRC relations = 2
- U.S./Japanese relations = 3
- U.S./Western Europe relations = 4
- U.S./other country relations = 5

---

<sup>1</sup> See Chapter 3 of "A Guide to Network Construction and Utilization" for details on the assignment of these numbers.

Regardless of the network that is being used, the code for the section of the tree on relations between the United States and the Soviet Union will always end in 1.

Third, the node numbers are unique to each node and must be treated as such. Hence, if any digit in the node number is transposed or omitted, the user will not obtain the node that is being sought. Moreover, if the period--as demonstrated in Table 1--is omitted, the user will not receive the node that is being sought. It is extremely important to enter the node exactly since any variation will create errors.

#### EQUIVALENCE CODING

In addition to a code for each node in the networks, a second code was developed for each of the first-, second-, and third-order effects in each network. A similar code was developed for each catalytic event that has been networked. The purpose of these codes is to help find cross-over points to permit the user to cross-over from one network to another when occurrences in one of the networks have implications for occurrences in a second network.

In developing the equivalence code, seven pieces of information were coded for the contents of the node to attempt to summarize the occurrences there.

- The first actor (the primary initiator of the actions described in the node).
- The second actor (the secondary initiator of the actions described in the node).
- The action taken in the node (activities described in this specific node).
- The first target (the country toward which the action in the node is primarily directed).
- The second target (the country toward which the action in the node is secondarily directed).

- Geographic region (where the action described in the node occurred).
- Substantive topic (subject about which the exchange described in the node occurred).

This information has been coded for each first-, second-, and third-order effect in each network. The codes used can be found in Appendices III through VII of the "User's Manual for the FORECAST 90 Computer Programs."<sup>2</sup>

Once the nodes were coded for these seven pieces of information, equivalence was sought to find nodes that had the same actor, action, target, geographic region, and substantive topic. Once commonly structured nodes were found, they formed cross-over points that were used to link together different networks. Figure 3 displays two unrelated networks that have commonly structured nodes (designated by letters). Figure 4 shows the use of the cross-over points to join--or "integrate"--the two separate networks.

All of the 52 networks currently available for FORECAST 90 have been examined for cross-over points and integrated. Where a node in one network crosses to another node in a second network, a particular statement--called a GO TO statement--is used to designate the occurrence. Thus, when the user prints a part of a network on the computer he may see GO TO statements at one or more nodes that are followed by a number. The number given refers to the location in the same tree or in another tree to which the first node is to branch. Additionally, at the end of each printing of a network section, the user can obtain a list of the GO TO statements encountered in that printing. This list of statements shows where the cross-overs have occurred and indicates what trees should be examined to print the nodes to which the cross-overs have been made.

---

<sup>2</sup> A more detailed discussion of network integration is found in Chapter 4 of "A Guide to Network Construction and Utilization."

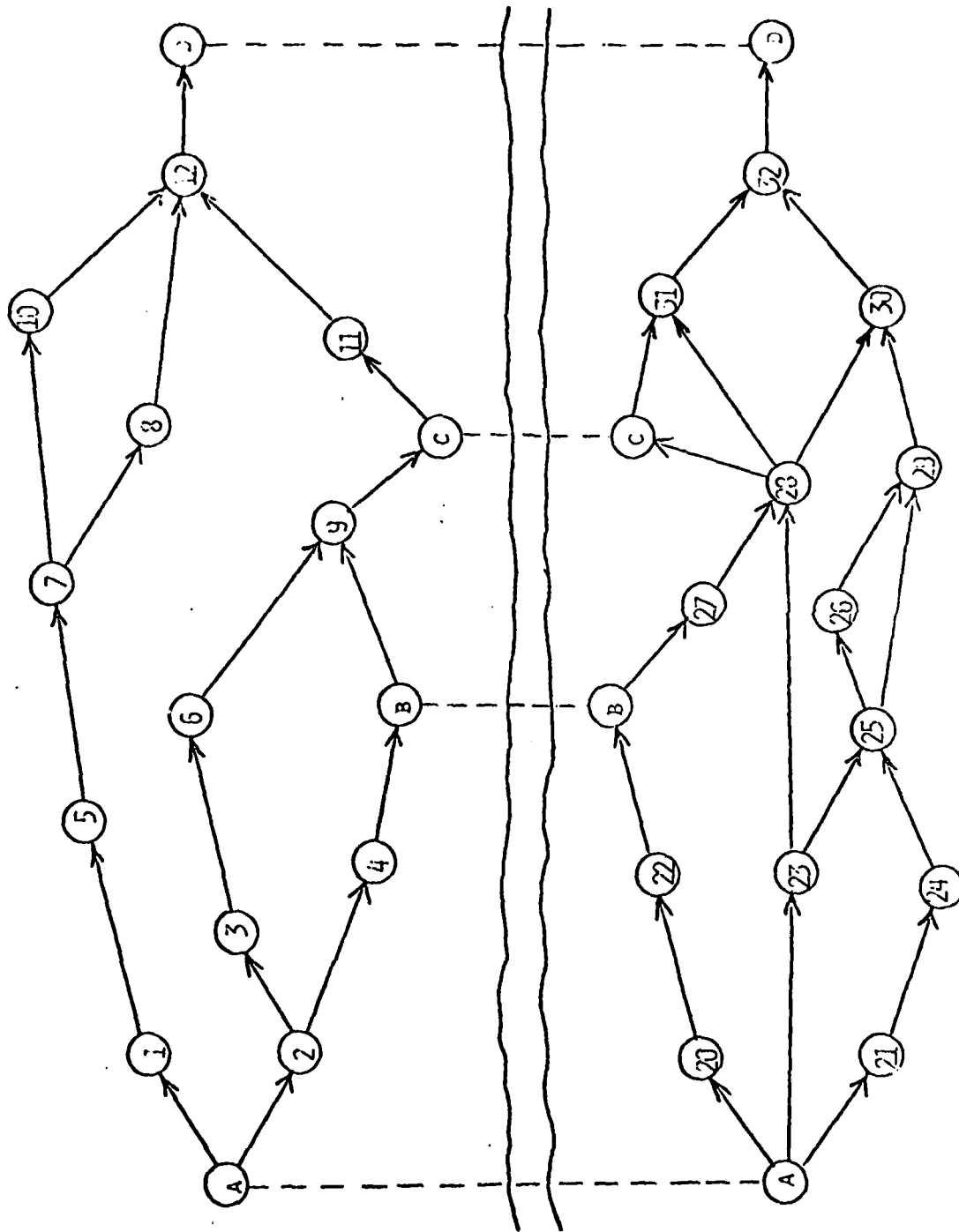

Figure 3. Two Distinct Networks with Potential Cross-Over Points

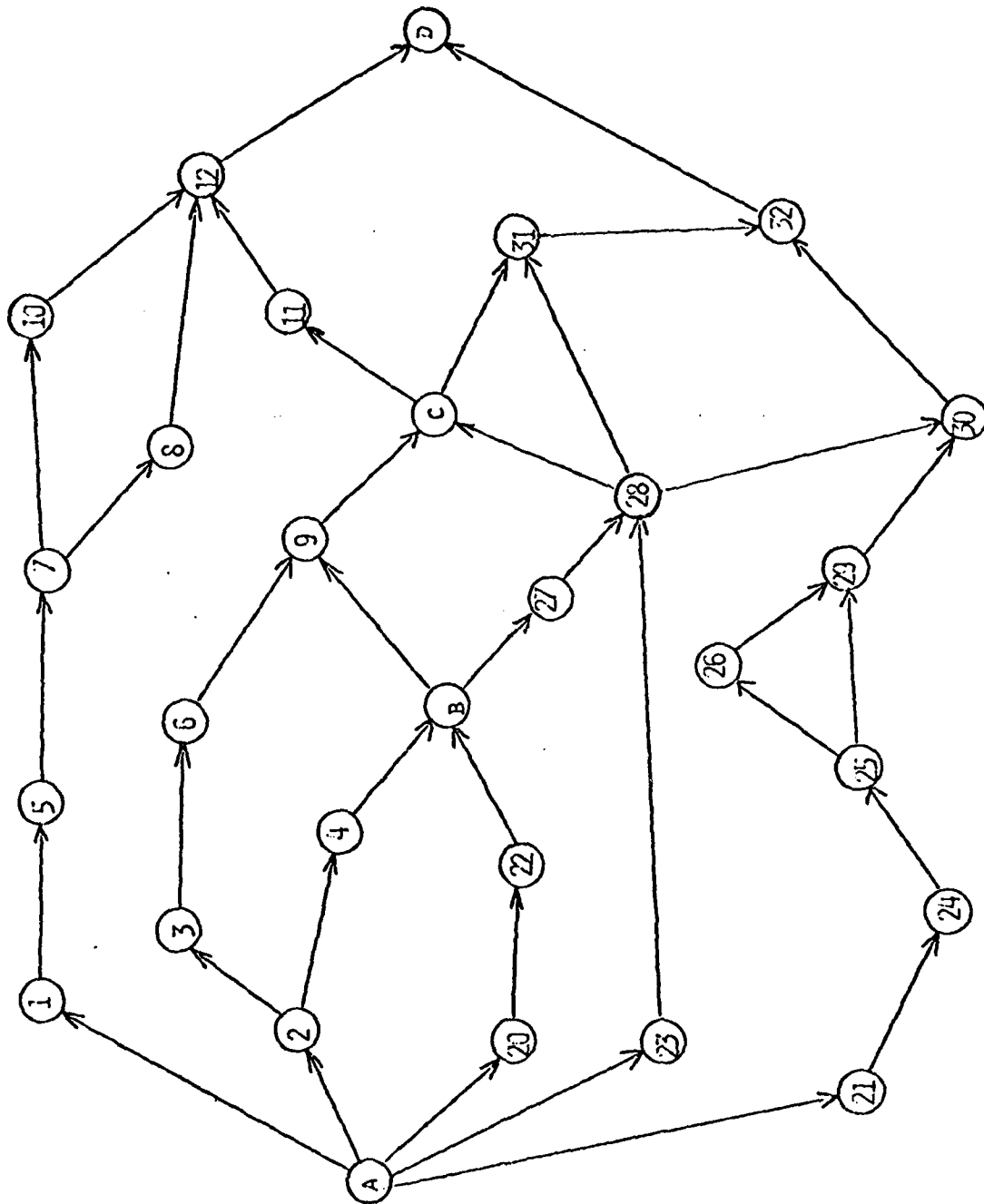

Figure 4. Two Integrated Networks

---

## GENERAL INFORMATION ON THE FORECAST 90 PROGRAMS

---

Four computer programs have been developed for use with the FORECAST 90 networks and related data files. These programs are written in FORTRAN and, except for NET2, are interactive. Use of the programs is described in the companion "User's Manual for the FORECAST 90 Computer Programs." The program documentation given in this manual will include a general statement on the programming philosophy, a discussion of the structure of the required data file, and description of each program (including operational-level flow diagrams, definitions of the variables and annotated program listings in the Appendices).

Table 2 presents a brief summary of information on the FORECAST 90 programs.

TABLE 2  
Summary of FORECAST 90 Programs

<u>Program Name</u>	<u>Type</u>	<u>Objectives</u>	<u>Input File</u>	<u>Function</u>
NET1	Interactive	Search a data file for the structure of a single network.	Network Files. Each file contains node designations and text for all nodes in a single network. There are 52 files with between 54-423 nodes per network.	To print portions of a single network selected by the user.
NET2	Batch	Search a data file for all nodes with an equivalent structure.	Node Information File. Each file record provides summary information on the structure of action in each node in each network. There are presently 5000 records in the file.	To identify and print for each node of each network all nodes in that network and in other networks that have the same action structure.
NET3	Interactive	Search a data file for all nodes with a structure that is equivalent to the one specified by the user.	Node Information File.	To identify and print information on the location of equivalence structure specified by the user as found in any of the 52 networks.
NET4	Interactive	Summarize the status of all networks presently stored in the system.	Tree Summary File. Information is included for each network on the substance of the net, the date of the net, the date of completion, last date of revision, and number of nodes in the network.	To print information on the content and status of the networks selected through criteria specified by the user.

---

NET1: A NETWORK DISPLAY PROGRAM

---

GENERAL PROGRAMMING PHILOSOPHY

Figure 5, which shows a very simple tree, indicates the way in which the terms "node" and "level" will be used. It is seen there that a node is a branch point in a "tree." Each tree has 8 levels. The first three levels have one node each; level 4 has five nodes; the number of nodes in the higher levels may vary from tree to tree, but the number of nodes in levels 7 and 8 is always the same within a single tree.

Each node is identified by a 7-character node designation. The first character of the node designation is always one of the letters: E (economic), P (political), M (military), S (socio-psychological), or T (technological). Examples are shown below:

<u>Level</u>	<u>Full Node Designation</u>	<u>Unique Part of the Node Designation</u>
1	P01.	<u>-<sup>a</sup></u>
2	P0101.	-
3	P010101.	-
4	P0101011.	1
5	P01010111.	11
	P01010112.	12
6	P010101111.	111
	P010101121.	121
7	P0101011111.	1111
	P0101011211.	1211
8	P0101011111.H001	1111(1) <sup>b</sup>
	P0101011211.H002	1211(1)

---

<sup>a</sup> Since there is only one node in each of the first three levels, no unique designation is necessary.

<sup>b</sup> The last 1 is added by the program.

PARENT OF LEVEL 'K' CHILDREN OF 'K'

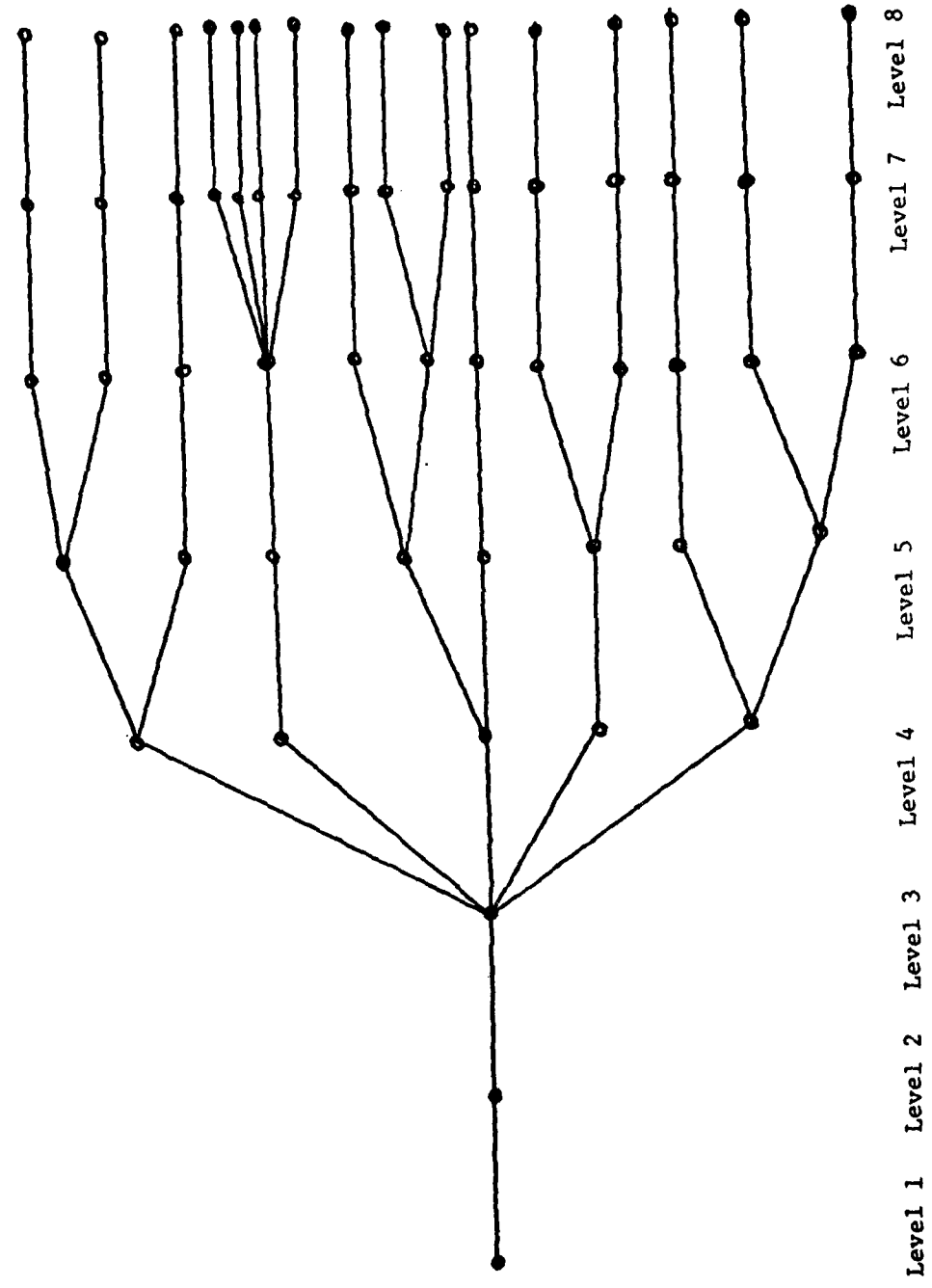

Figure 5. Schematic Diagram of a Very Simple Decision Tree

Because of the structural similarity of these decision trees to "family" trees, it is convenient to refer to nodes in terms of family relationships. Thus, the nodes in level K+1 are called the "Children" of the nodes in level K; nodes in level K-1 are the "Parents" of level K nodes; and nodes in level K-2 are the "Grandparents."

Basic program operation depends on the fact that nodes may be referred to:

- By the node designation discussed above, and
- By a node index giving the order of the node in the input file.

Efficient searching through the tree is permitted by the following relationships among the designations of the nodes in adjoining levels:

$$\text{Parent Node} = \text{Child Node} / 10 \quad (1)$$

$$\text{Child Node} = \text{Parent Node} \times 10 + j \quad (2)$$

where  $j = 1, \dots$  number of branches at Parent Node.

Equation (1) depends on the fact that, in FORTRAN, integer division loses any non-integer part. For example  $(221/10) = (222/10) = (223/10) = 22$ . Thus, all Brother Nodes produce the same Parent Node.

The node "index" is used as the index of arrays in which node attributes are stored--for example, NBR (number of branches at the Ith node), NOD (designation of the Ith node), LIN (number of lines in the Ith node's message). Thus, the number of branches at the Ith node is given by NBR (I).

#### File Structure

Information for each of the 52 networks is organized by node in a separate file for each. All data for a single node are stored on consecutive lines

in the file. The following information is retained in the file for each node:

- Node designation - a set of alpha-numeric characters (up to 16) that identify both the tree and the node within the tree.
- Node level - the location in the network for a specific node.
- Number of branches at the node.
- Lines of text - each line is limited to 32 characters, but there is no limit to the number of lines per node (subject to the general limitation of 1500 lines for the entire tree).
- GO TO lines - pointers to related nodes.

A listing of a few lines from one of the tree files is shown in Table 3. This file has the following format:

<u>Type of line</u>	<u>Columns</u>	<u>Variables</u>
Node	1	Node level
Designation	3	Number of branches
Line	2-18	Node designation
Text Line	1	Blank if an additional line of text or a GO TO line follows: / if this is the last line and there are no GO TO lines.
	2-33	Text
GO TO Line	1	Line identifier: Must be *. Any text: for example, *GO TO P010204121.

#### PROGRAM DESCRIPTION

NET1 is made up of a main control program and five major subroutines: SF, SB, SR, CHILD, and PRINT. Flow diagrams showing the operations carried out by these programs are given in Figures 6-11.

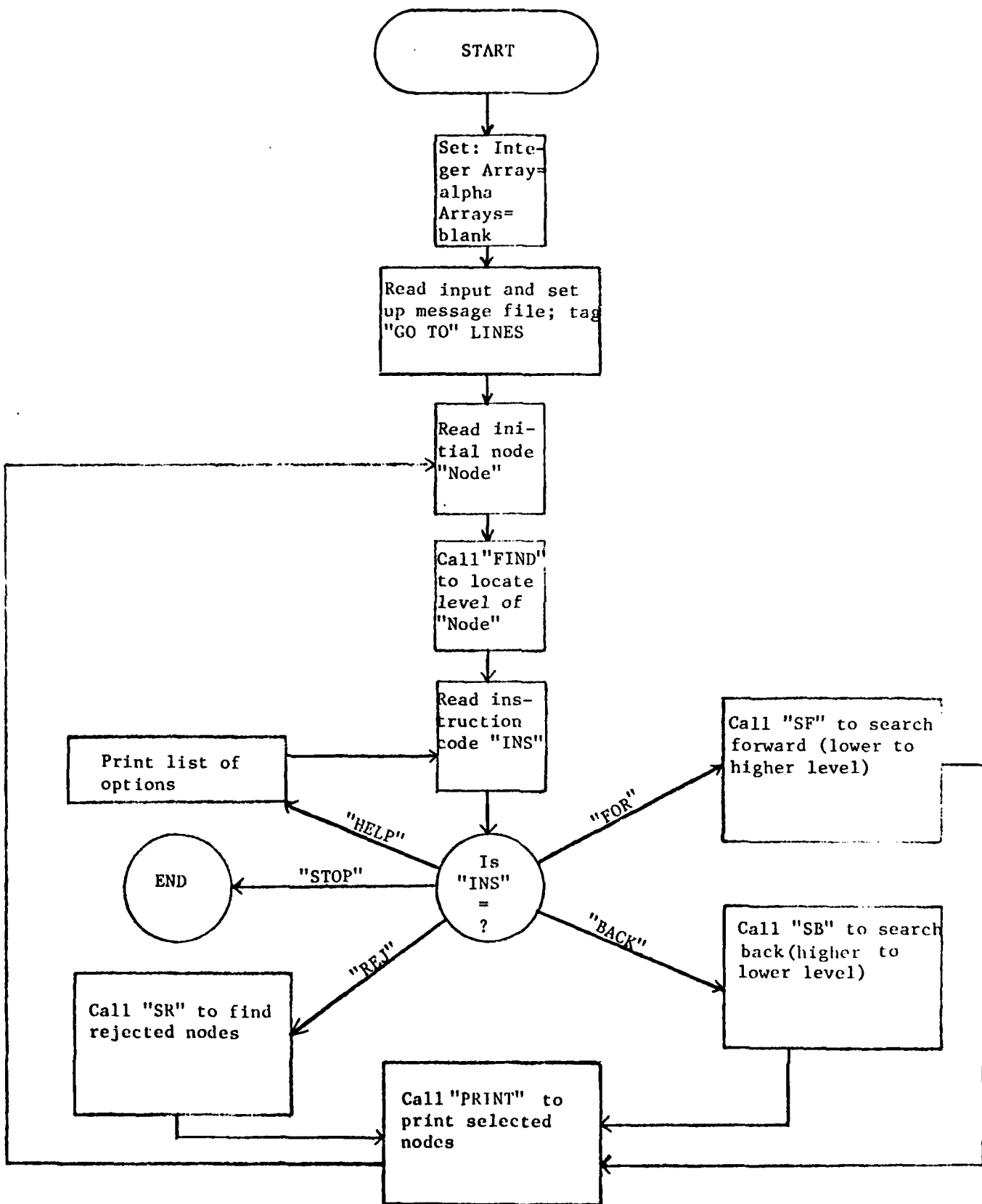
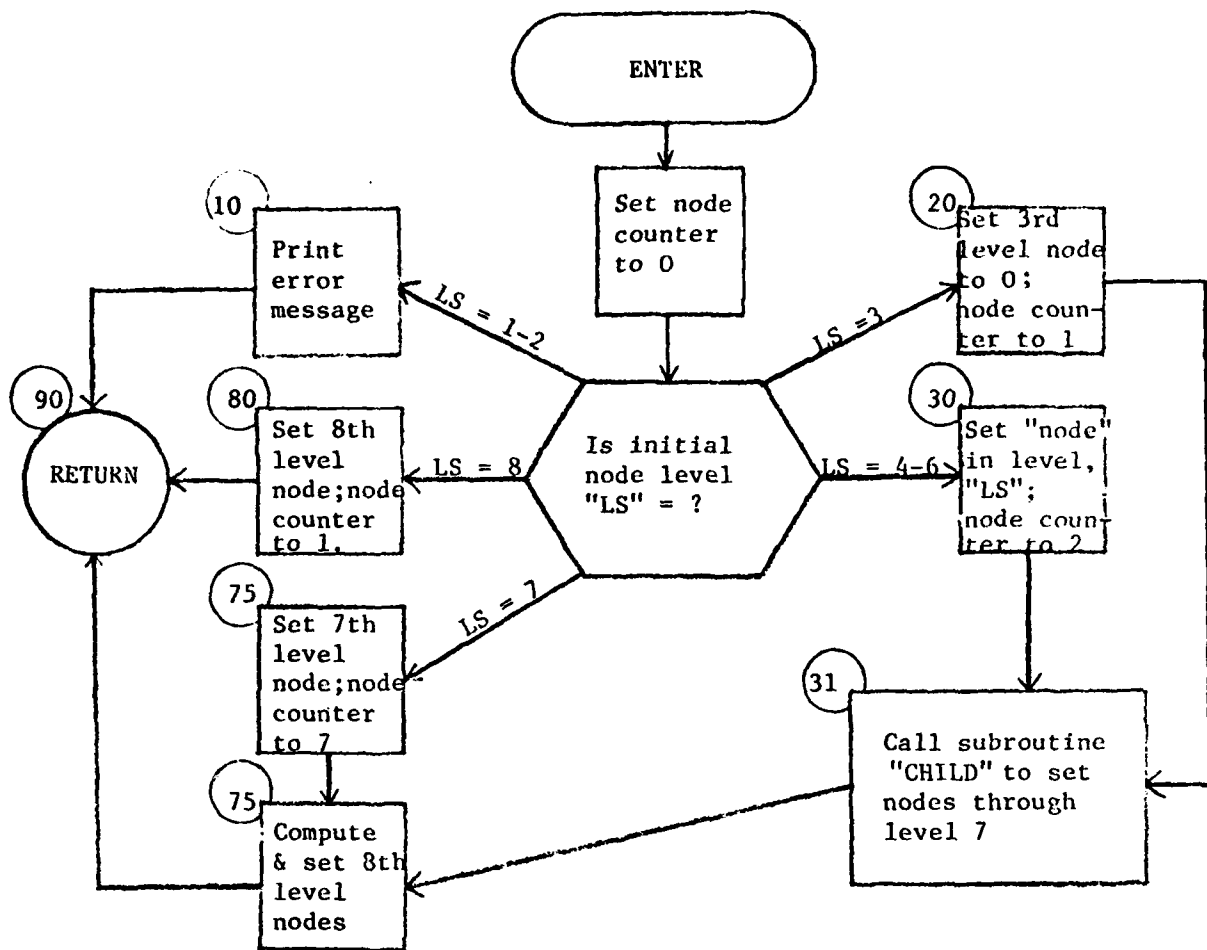

Figure 6. NET1 - Main Program



XX XX= Statement No. (See Program Listing, Appendix)

NODE - Initial Node Designation

LS - Initial Node Level

Figure 7. NET1: Subroutine SF (LLX, NEV, NODE, LS)

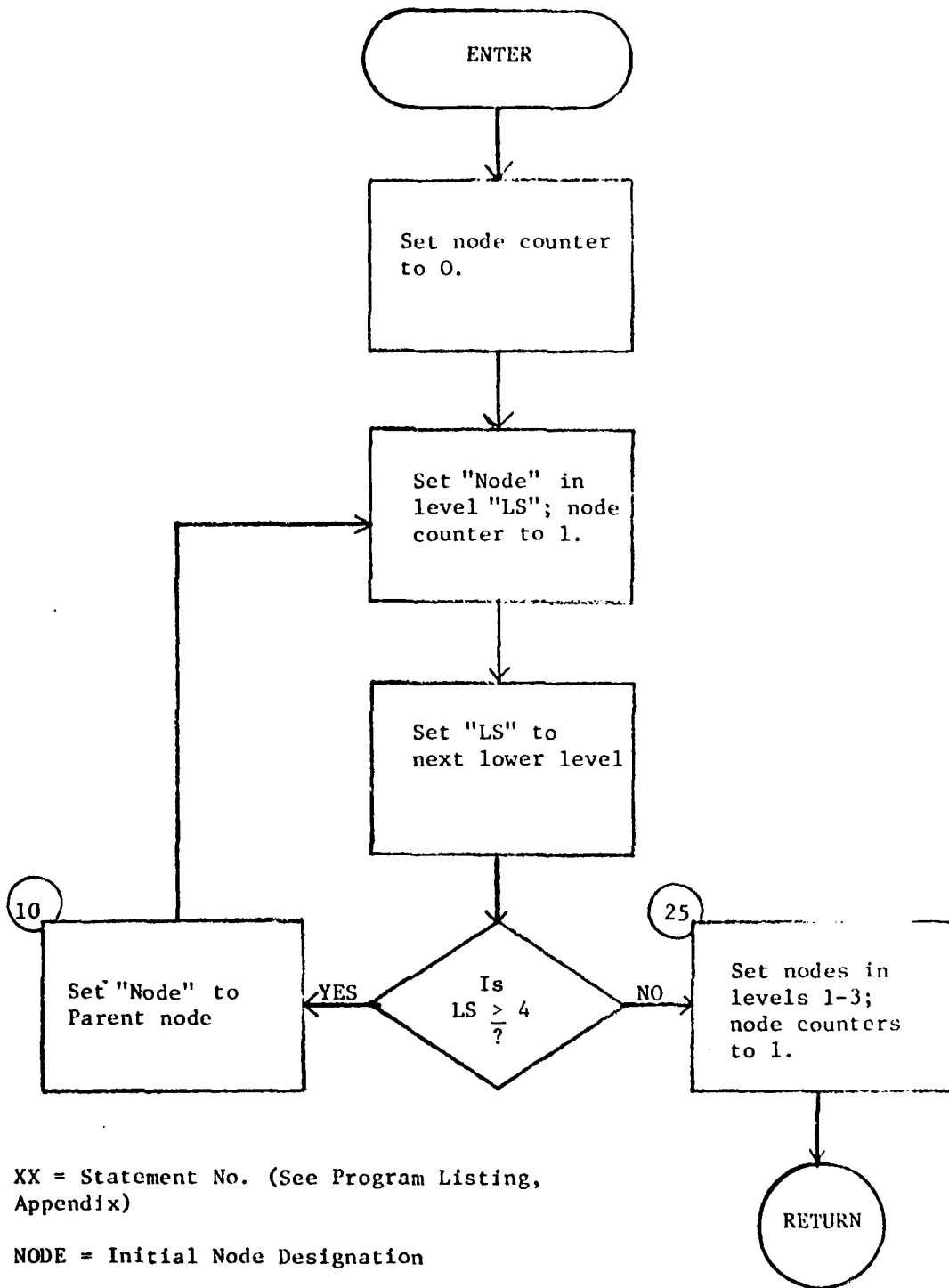
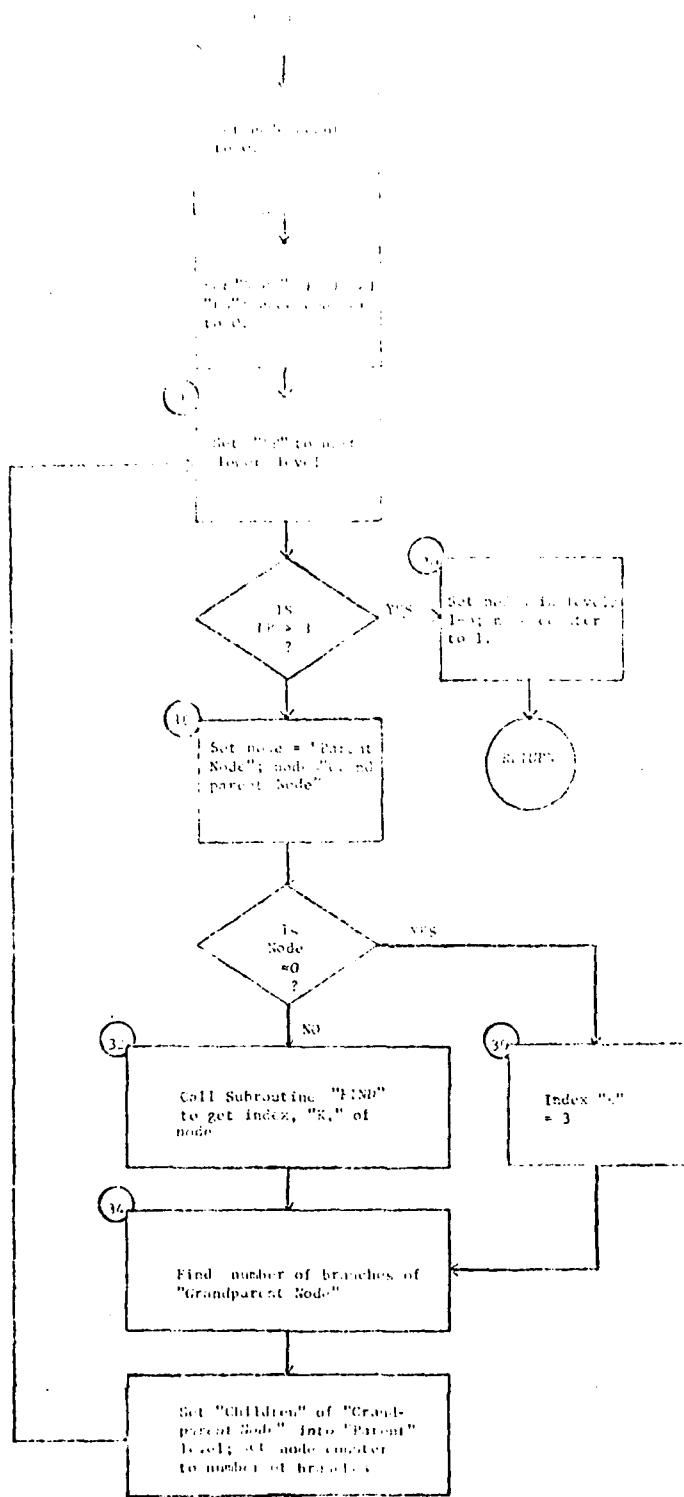
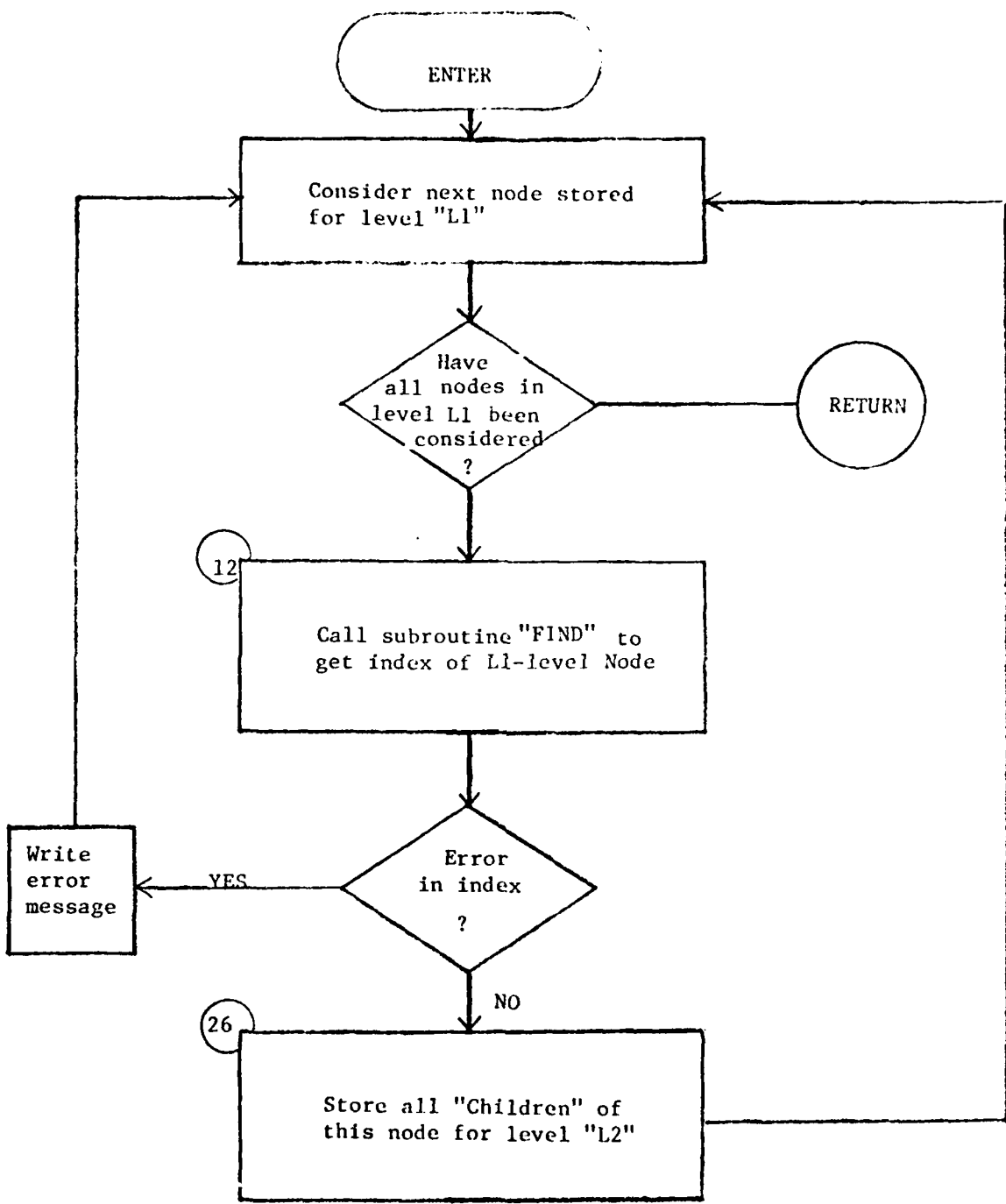

Figure 8. NET1: Subroutine SB



(1) XX = Statement No. (See Program Listing Appendix)  
 0000 = Initial Node designation  
 05 = Initial Node Level

Figure 9. RFI1: Subroutine SE



XX = Statement No. (See Program Listing, Appendix)

Figure 10. NET1: Subroutine CHILD

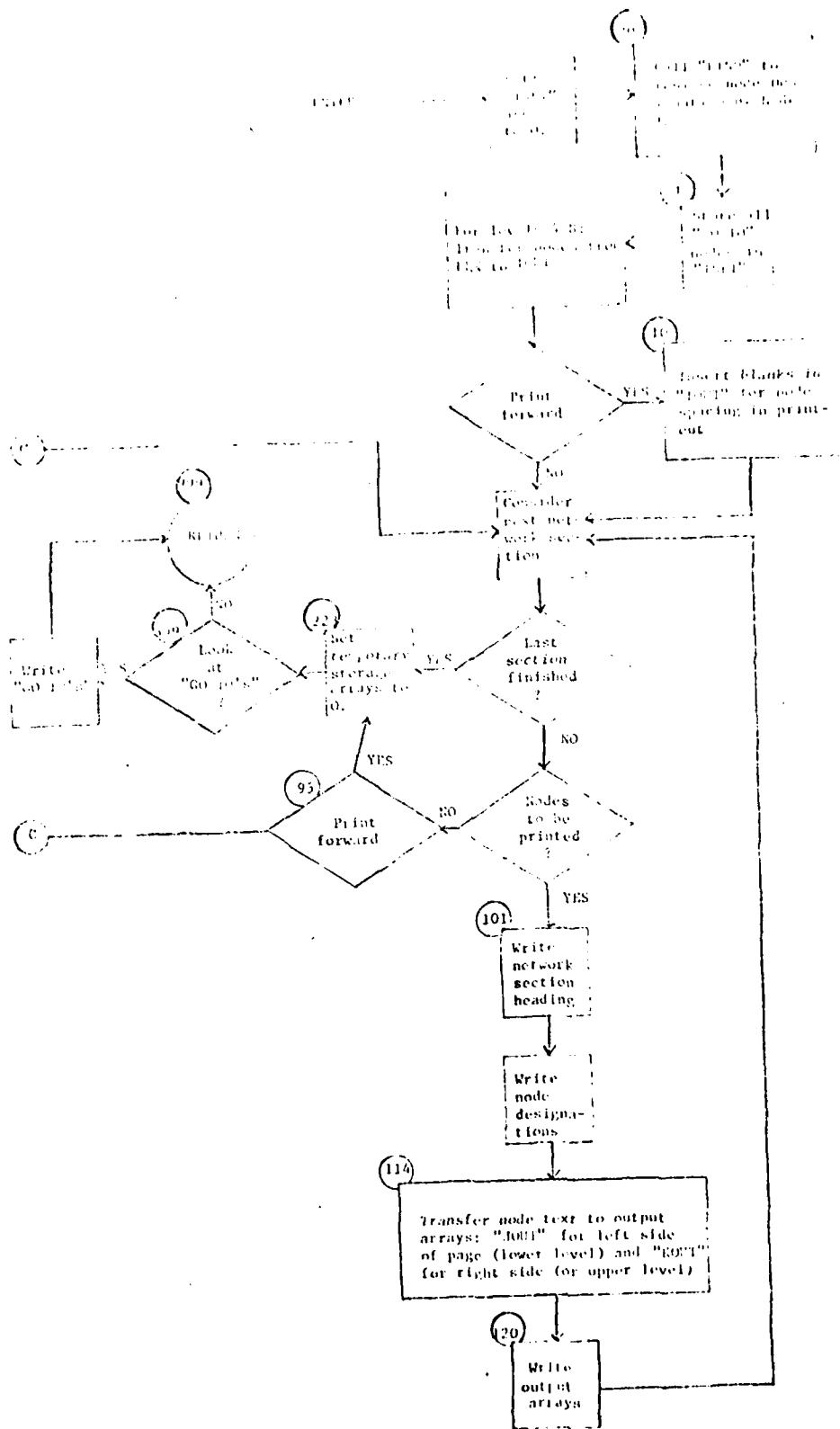

XXX - Statement No. (See Program Listing Appendix)

Figure 11. NET: Subroutine PRINT

TABLE 3

Sample of the NET1 Input: A Portion of One of the Tree Files

71T010201432.	Node designation line
LDC'S REJECT US OFFER FOR TECHNICAL ASSISTANCE IN FAVOR OF EUROPEAN TIES.	Text line
*GO TO S0105021311.	GO TO line
*GO TO S010502412.	
71T0102014321.	
EUROPE ACCEPTS US PRESENCE IN LDC'S	
*GO TO E01040142.	
71T0102014322.	
EUROPE REJECTS US PRESENCE IN LDC'S COMPETES WITH US FOR LDC MARKETS.	
*GO TO T010201431.	
71T0102014331.	
/NO THIRD ORDER EFFECT.	
71T0102014341.	
/NO THIRD ORDER EFFECT	
71T0102015111.	
/NO THIRD ORDER EFFECT.	
71T0102015121.	
LDC'S HOLD RAW MATERIALS TO BARTER FOR TECHNOLOGY TRANSFER PROGRAMS.	
*GO TO T01020152.	
71T0102015122.	
LDC'S REJECT TECHNOLOGY FOR MORE CONVENTIONAL TYPES OF AID" POLITICAL, /ECONOMIC, MILITARY.	
71T0102015211.	
US FORCED TO LOOK ELSE- WHERE FOR RAW MATERIALS STOPPED IN RESPONSE TO US /AID CUTOFF.	
71T0102015221.	
LDC'S BREAK AWAY FROM EUROPE-SELL RAW MATERIALS TO HIGHEST /TECHNOLOGICAL BIDDER.	
80T0102014223.H041	
(-) RATE OF CHANGE OF TECH- NOLOGY DECREASED. HIGH TECHNOLOGY FIRMS RELYING ON EXPORTS ARE FORCED OUT OF /BUSINESS.	

In addition to these programs, two minor utility subroutines, FIND and LEVEL, are included to determine the index and level, respectively, for a given node. Definitions of the variables are given in Table 4.

TABLE 4  
Definitions of the NET1 Variables

<u>Variable Name</u>	<u>Definition</u>
<u>Arrays</u>	
NBR(I)	Number of branches at the Ith node.
NOD(I)	Designation of the Ith node.
LOC(I)	Location in the message file of the first line of the message for the Ith node
LIN(I)	Number of lines in the Ith node's message
NOF(I)	Final part of the node designation
GTO(I)	Number of GO TO lines for this node
MES(L,K)	Text file (L=1,8 - Text /L=9 - tag for GO TO line
ISSET(I)	Temporary storage for nodes with GO TO lines
NEV(L)	Number of nodes in the Lth level selected for printing
NST(L)	Total number of nodes in the Lth level
LLX(L,I)	Temporary storage for the designations of level L nodes selected for printing
LL	Powers of 10 used in identifying node levels
II	Temporary storage for one message line during the input phase
BUFFER	Required by the computer system for subroutine ATTACH
<u>Single Variables</u>	
WORDS	Number of (computer) words in a single message line
MAXLN	Maximum number of lines in the message for any node in a given tree (computed by the program)
NNOD	Maximum number of nodes in any single tree
NLEV	Number of levels in a tree (currently set at 8)
NLLX	Maximum number of nodes per level that could be selected during any single search
MMES	Maximum number of lines for all messages for a single tree

---

NET2: A BATCH MODE EQUIVALENCE SEARCH PROGRAM

---

PROGRAMMING PHILOSOPHY

The purpose of this batch program is to identify nodes with similar characteristics across the entire set of trees. The input file for NET2 is the Node Information File (NIF) which contains the following information for each node:

- (1) Node designation
- (2) Actor
- (3) Event
- (4) Target
- (5) JCS geographic region
- (6) Substantive topic

All nodes for which variables (2)-(6) are the same are considered to belong to the same "group." As each record is read, the group to which the node belongs is identified and stored with the other node attributes. This group identification is carried out by the following procedure:

Group 1 is defined by the attributes of the first node in the data file. If the second node is equivalent to Node 1, it is placed in Group 1; otherwise, its attributes define Group 2. If the third node is equivalent to either of the first two nodes, it is placed in the first or second group; otherwise, its attributes define Group 3.

When all of the nodes have been read, they are printed by groups. A pass is made through the list of nodes, and the nodes whose designations start with E are selected. Each E node serves as a "key" node (that is, it is

printed at the left side of the page) and the designations of all nodes equivalent to it are printed to the right. Thus, each equivalent group is printed once for each member of the group. When all E nodes have been used as key nodes, the process is repeated with all M nodes, then P, S, and T nodes. (The order is controlled by the order of the values of the control variable, KON--set in a data statement. See the program listing in Appendix II.)

#### FILE STRUCTURE

Table 5 shows a listing of a few lines of the Node Information File. This file has the following format.<sup>3</sup>

<u>Columns</u>	<u>Variables</u>
1-11	Node designation
13-15	First Actor code (what country initiated the action)
16-18	Second Actor code
19-21	Action node (what the action was)
22-24	First Target code (toward what country or group was the action directed)
25-27	Second Target code
28	Region code (the geographic location of the action)
29-31	Substantive topic code (the subject topic of the exchange).

#### PROGRAM DESCRIPTION

NET2 consists of a main control program only. The flow diagram in Figure 12 indicates the operations carried out by the program. Definitions of the principal variables are given in Table 6.

---

<sup>3</sup> In the present program only parts of a larger data file are read. Thus, the actual data file contains information on two actors, two targets, and a three-digit code for action and substantive topic. Only one actor, one target, and two digits of the action and substantive topic codes are currently used in the search.

TABLE 5

Sample Listing of the Node Information File (NIF)

Node Designation	First Actor Code	Second Actor Code	Action Code	First Target Code	Second Target Code	JCS Region Code	Substantive Topic Code
F0101013211	740000	060997	0000	101			
F0101013221	997000	011740	0000	133			
F0101013221	740000	011097	0000	133			
F0101013222	997000	023374	0000	133			
F0101013222	740000	023399	7000	133			
F0101013222	740000	061995	0000	130			
F0101013231	740000	061995	0000	130			
F0101013232	740000	022199	7000	133			
F0101013311	740000	022199	7000	100			
F0101013312	740000	032997	0000	147			
F0101013312	740000	171995	0000	130			
F0101013321	740000	142002	9970	130			
F0101013322	740000	171997	0020	107			
F0101013331	740000	133002	0000	107			
F0101013332	740000	022100	2000	100			
F0101014121	397000	165995	0003	130			
F0101014122	397000	165995	0003	147			
F0101014122	397000	165995	0003	130			
F0101014131	397000	171002	9970	107			
F0101014132	397000	176997	0000	103			
F0101014133	397000	176002	0000	103			
F0101014141	397000	105002	0000	130			
F0101014142	397000	202002	0000	130			
F0101014221	397000	165995	0003	147			
F0101014221	397000	165995	0003	130			
F0101014222	397000	143650	0000	140			
F0101014223	397000	202002	0000	130			
F0101014321	397000	215002	0000	130			
F0101014322	397000	051002	0000	137			
F0101014331	397000	215002	0000	130			
F0101014332	397000	051002	0000	100			
F0101014411	002000	024039	7000	100			
F0101014412	002000	005139	7000	100			
F0101014412	002397	208995	0000	130			

↑↑↑ ↑ ↑↑↑ ↑

The (↑) designates columns not currently read by the program.

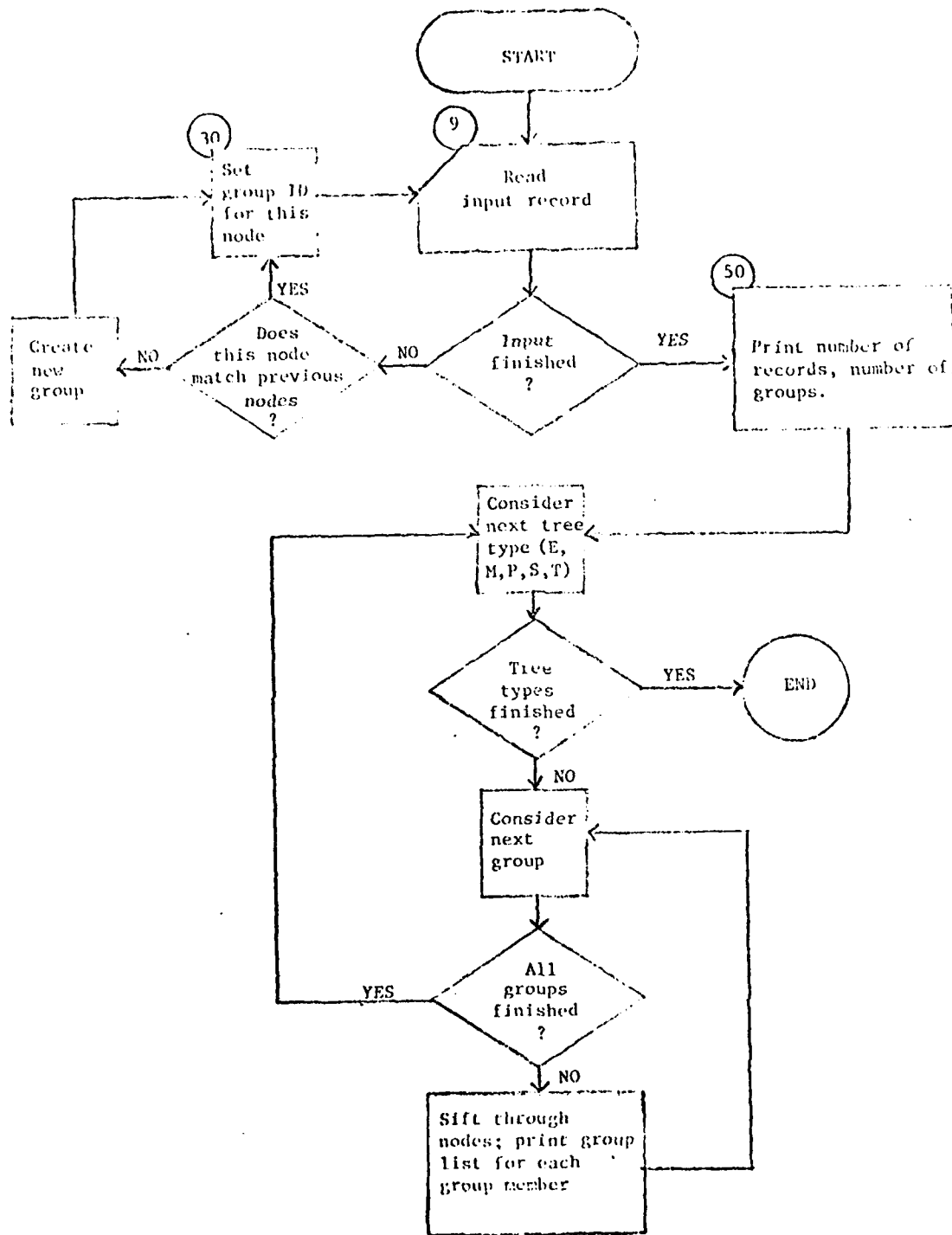

Figure 12. Program NET2

TABLE 6  
Definitions of the NET2 Variables

<u>Variables Names</u>	<u>Definition</u>
<u>Arrays</u>	
NN(I,J)	Designation of the Ith node (j=1,5; computer words are required)
II(I)	(Packed) word containing actor, event, and target codes for the Ith node
LR(I)	Geographic region code for the Ith node
LA(I)	Substantive topic code for the Ith node
IG(I)	Equivalence group of the Ith node
KON(J)	Letter code for the Jth tree type (J=E,M,P,S, and T)
N(K)	Input buffer (K=5)

---

## NET3: AN INTERACTIVE EQUIVALENCE SEARCH PROGRAM

---

### PROGRAMMING PHILOSOPHY

This interactive program reads the Node Information File (NIF)--which was described for NET2--and allows the user to print information on nodes selected by one or more of their attributes. Thus, a user may ask to see all node entries with actor code 365, or all node entries with substantive topic code 09, or all entries with actor code 365 and substantive area 09.

The program reads the user's responses to questions designed to elicit his selection criteria and sets up a selection array, each word of which contains either the user's selected code for the corresponding attribute or the value -1 indicating that this variable is not used in the selection process.

### PROGRAM DESCRIPTION

NET3 consists of a main control program and a utility subroutine to convert alpha-characters to integers. The flow diagrams in Figures 13A and 13B indicate the operations carried out by the program. Definitions of the arrays are given in Table 7.

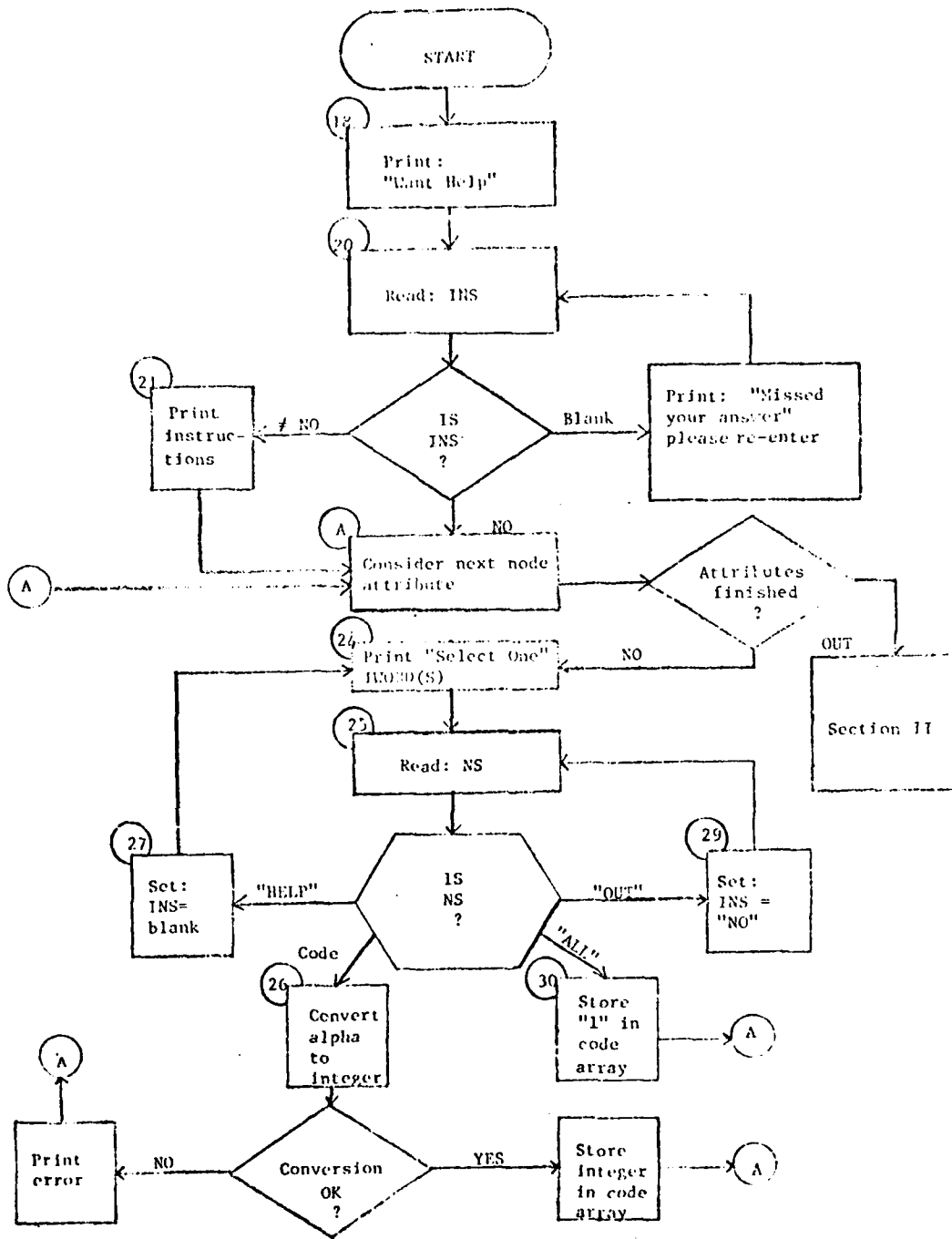

Figure 13A. NET3: Section 1: Read User's Selection Code

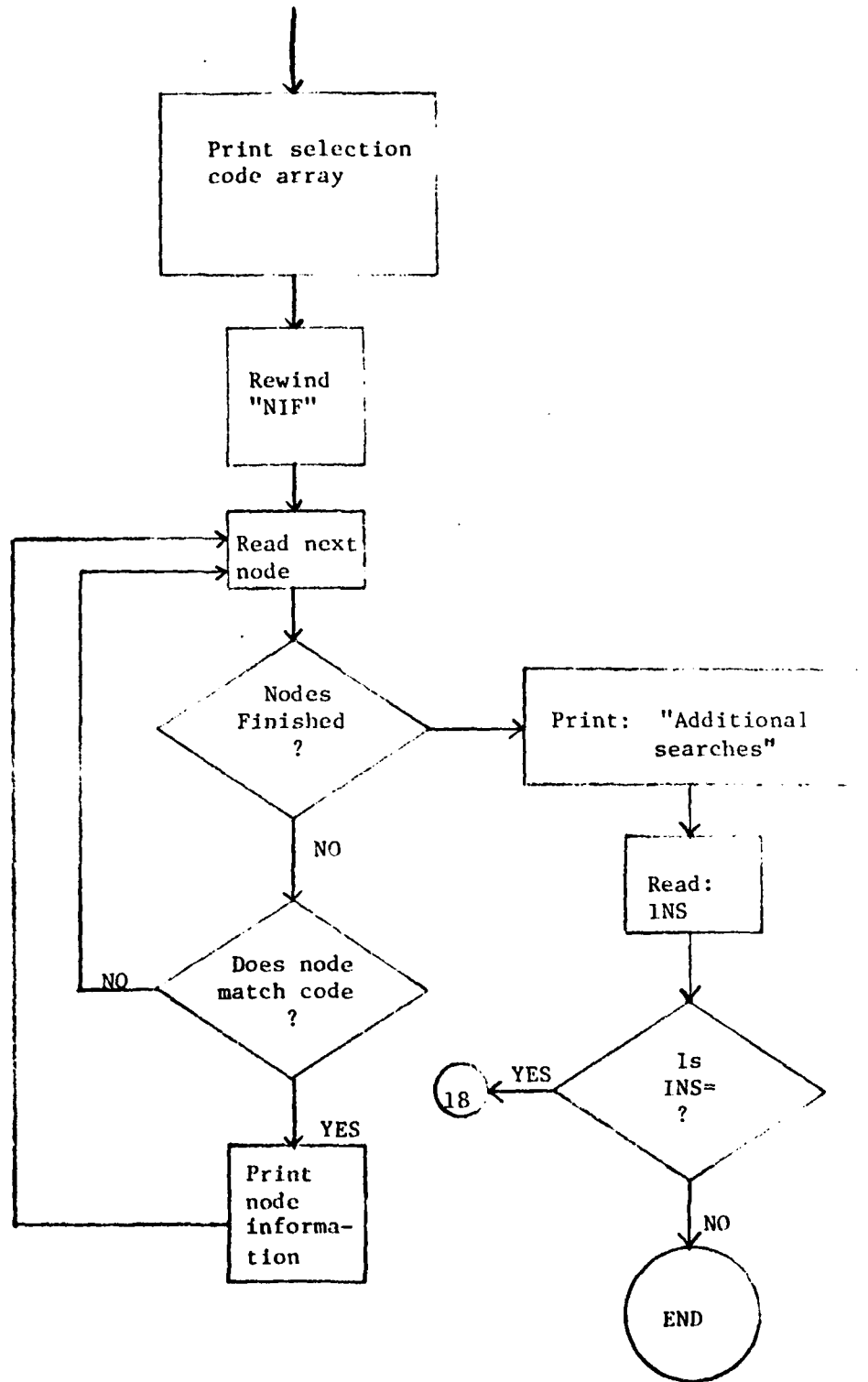

Figure 13B. NET3: Section II: Search Node Information (NIF) for Matches to Selection Code.

TABLE 7  
Definitions of the NET3 Variables

<u>Variable Name</u>	<u>Definition</u>	<u>Format</u>
<u>Arrays</u>		
IWORD(K) (K=1,5)	List of the selection code	A4
IXX(I,1)	Actor code for the Ith node	I3
IXX(I,2)	Action code for the Ith node	I2
IXX(I,3)	Target code for the Ith node	I3
IXX(I,4)	Geographic region code for the Ith node	II
IXX(1,5)	Substantive topic code for the Ith node	I2
NN(I,K) (K=1,3)	Designation of the Ith node (3 variables)	A4,I5,A4
BUFFER	System variable required for file handling	

---

NET4: A NETWORK SUMMARY PROGRAM

---

PROGRAMMING PHILOSOPHY

NET4 allows the user to search the Tree Summary File (TSF) for information across the entire set of trees.

The user may retrieve and print information for trees selected by any of eight variables. In addition to displaying sections of the TSF, the command set allows the user to modify file entries and to add new ones (although these latter functions may also be carried out with the USAWC computer system's EDIT command).

FILE STRUCTURE

The Tree Summary File contains the following information for each of the networks in the FORECAST 90 system:

- Tree number
- Author of the tree
- Date of tree creation
- Date of last tree modification
- Total number of nodes in the tree
- Actor code
- Substantive topic code
- Region code
- One line of text describing the subject matter.<sup>4</sup>

---

<sup>4</sup>

More complete information on the catalytic events used to build the networks is given in Appendix I of the "User's Manual for the FORECAST 90 Computer Programs." Information on the actor, substantive topic and region codes is given in Appendices III-VII of that manual.

TABLE 5

Sample Listing of the Tree Summary File (TSF)

Tree Number	Tree Author	Date Created (Yr., Month, Day)	Date Modified (Yr., Month, Day)	Number of Nodes	Actor Code	Substantive Area Code	Region Code	Description
E012101	CACI 750327	750707	101 691 14 25					OLD EMERGO AGAINST WESTERN STATES BY MIDDLE EASTERN COUNTRIES.
E012102	CACI 750327	750707	133 022 14 01					US GRAIN EMERGO.
E012103	CACI 750327	750707	154 397 14 03					SEC ATTEMPT TO BECOME RESOURCE INDEPENDENT BY TRADE PACTS WITH LDCS.
E012104	CACI 750327	750707	24 596 14 02					CARTILIZATION OF COPPER.
E012201	CACI 750327	750707	113 740 14 07					JAPAN-USSR TRADE/AID PACTS TO DEVELOP SOVIET ENERGY SOURCES.
E012301	CACI 750327	750707	170 397 14 03					EUROPEAN ECONOMIC INTEGRATION.
E012302	CACI 750327	750707	09 002 02 01					SEVERE ECONOMIC RECESSION OCCURS IN THE US.
E012401	CACI 750327	750707	133 997 12 00					LDC'S PRESSURE DEVELOPED COUNTRIES FOR NEW AID SYSTEM.
E012501	CACI 750327	750707	101 397 14 03					EEC BREAKS DOWN FROM STRAINS OVER RESOURCE AVAILABILITY.
E012601	CACI 750327	750707	70 365 17 04					USSR EXPANDS STRATEGIC WEAPONS, SEEKS FIRST STRIKE CAPABILITY.
E012701	CACI 750327	750707	137 002 07 03					NBR UNSUCCESSFUL. CONGRESS MANDATES 50,000 TROOP WITHDRAWAL.
E012801	CACI 750327	750707	54 002 07 00					US LOSES BASE/TRANSIT RIGHTS IN SOUTHERN EUROPE AND MIDDLE EAST.
E012901	CACI 750327	750707	172 002 07 07					US LOSES BASE/TRANSIT RIGHTS IN JAPAN AND OKINAWA.
E013001	CACI 750327	750707	170 002 07 07					US LOSES BASE/TRANSIT RIGHTS IN THAILAND, TAIWAN, AND PHILIPPINES.
E013101	CACI 750327	750707	100 002 17 01					US NAVAL CAPABILITY INCREASED WITH SURFACE EFFECT SHIPS.
E013201	CACI 750327	750707	09 002 17 01					IMPROVED LOGISTICAL CAPABILITIES PERMIT RAPID US EASING ALMOST ANYWHERE.

Table 8 is a listing of a few lines of the Tree Summary File. This file has the following format:

<u>Type of Line</u>	<u>Columns</u>	<u>Variables</u>
Tree	1- 8	Tree number
Designation	10-13	Author
Line	15-20	Date created (year, month, day)
	22-27	Date modified (year, month, day)
	29-31	Number of nodes in the tree
	33-35	Actor code
	37-38	Substantive topic code
	40-41	Region code
Text Line	1-80	Up to 80 characters of text to describe the focus of the network.

PROGRAM DESCRIPTION

NET4 consists of a main program only. An operational level flow diagram is given in Figures 14A and 14B. Definitions of the variables are given in Table 9.

TABLE 9  
Definitions of the NET4 Variables

<u>Variable Name</u>	<u>Definition</u>	<u>Format</u>
<u>Arrays</u>		
IX(K,1) L=1,2	Tree name	2A4
IX(K,3)	Author of the tree	A4
IX(K,4)	Date tree was created	I6
IX(K,5)	Date of last tree modification	I6
IX(K,6)	Number of nodes in the tree	I3
IX(K,7)	Actor code	A3
IX(K,8)	Substantive topic code	A2
IX(K,9)	Geographic region code	A2
IX(K,L), L=10,29	Descriptive text	20A4
BUFFER	System variable required for file handling	

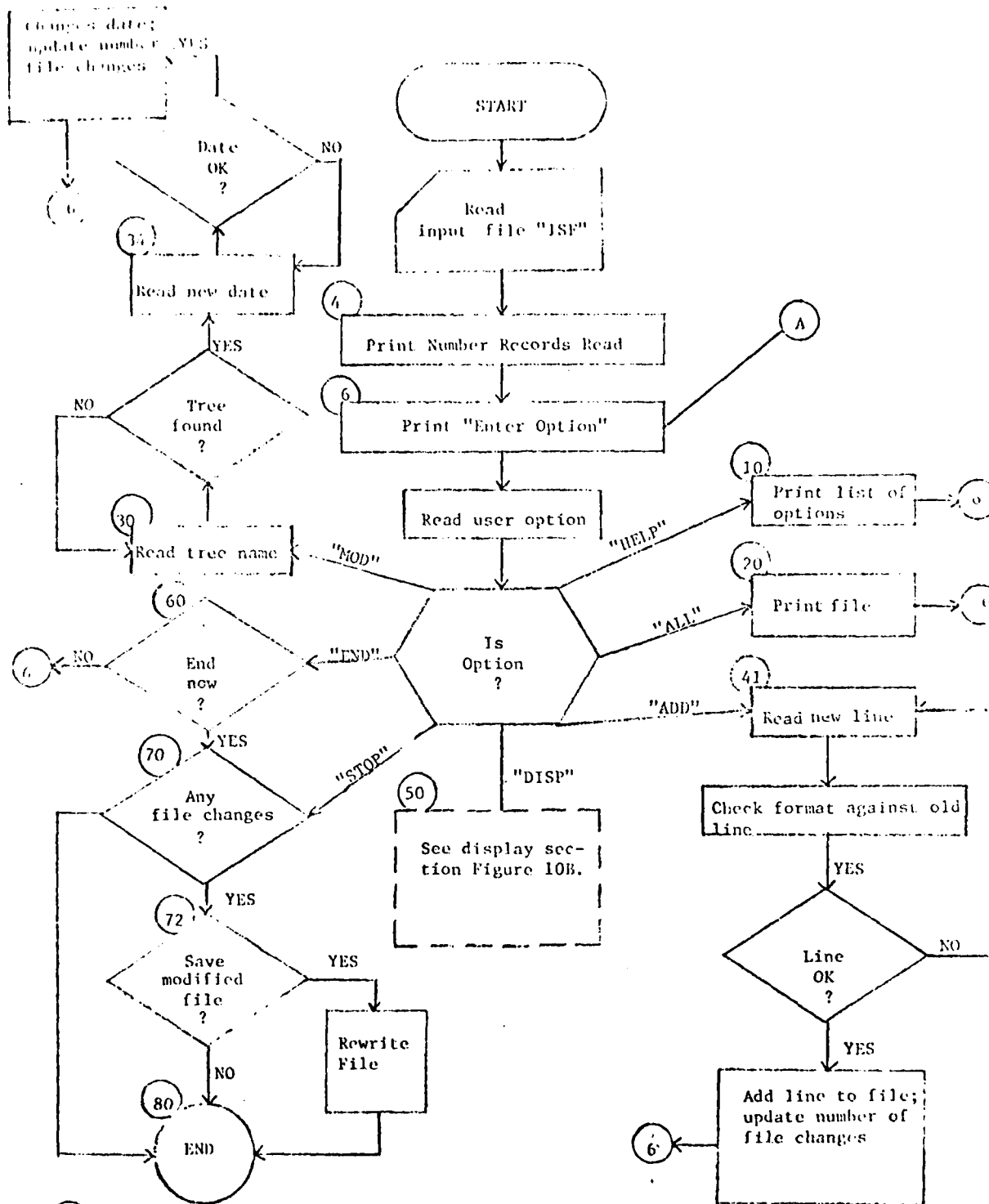

XX) XX = Statement No. (See Program Listing in Appendix)

Figure 14A. Program NET4: Option "MOD," "END," "STOP," "HELP," "ALL," and "ADD."

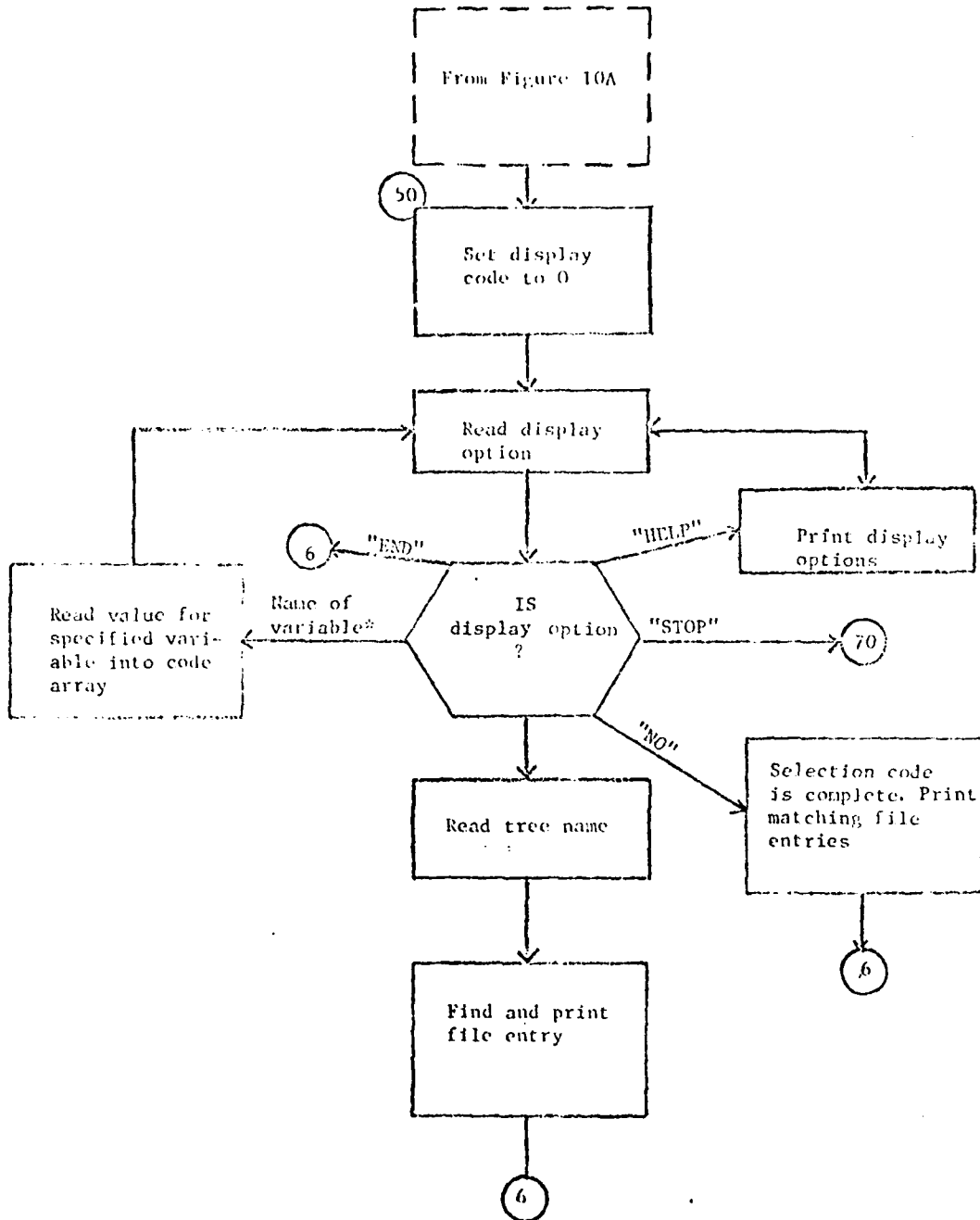

\* The descriptive variables by which file entries may be selected are: "AUTH," "DFC," "DFN," "ACT," "SUB," and "REG."

Figure 14b. Program NET4: Display Option.

---

GLOSSARY OF TERMS FOR THE NET PROGRAMS

---

Alpha-array	An array in which letters or other symbols are stored; it may be used in comparison statements but not in computations.
Message	The text, or descriptive material, accompanying a node (arranged in 32-character lines).
Node Designation	The set of letters and integers that identify a node; the name of the node.
Node Index	An integer specifying the order of the node in the input deck; used to index arrays containing node attributes.
Attribute	Numerical information about an entity; for example, the number of branches at a node is a node attribute.
Parent Node	The Parent Node of a node in, say, level K is the node in level K-1, directly connected to it. A given node may have only one parent.
Child Node	A child of a node in level K is a node in level K+1 directly connected to it. A Parent Node may have several children.

Appendix I; Annotated Program Listings for NET1

PROGRAM NET1

Purpose: To retrieve and print selected parts of a single tree.

MAIN CONTROL PROGRAM

Purpose: To process the input data describing the tree and to execute user-specified options.

```
10   DIMENSION GTD(600),LIN(600),LOC(600),NBR(600),NOD(600),NOF(600)
20   P,NEV(8),NST(8),LLX(8,90)
30   R,MES(9,1500),BUFFER(380)
40   COMMON GTD,LIN,LOC,NBR,NOD,NOF,MES,NST,LLX,NEV
50   R,WORDS,NM1,NM2,NM3,MAXLN,IFO
60   ASCII ANS,IW,IFILF(6),JW,NO
70   DIMENSION LL(7),II(8),KS(5)
80   INTEGER WORDS,GTD
90   DATA NNOD,NLEV,NLLX,NMES/600,8,90,1500/
100  DATA KS/3HFOR,3HBAC,3HRFJ,3HSTO,3HHEL/
110  DATA IFILE/"AWC1","SS/C","ACI/","      ","      ";  "/"
120  DATA IAS,LANK/1H*,1H /,NO/2HNOZ/-----
```

Pre-processing phase. Integer arrays are set to 0; alpha arrays, to blanks.

---

```
130  PRINT,"THE NET1 PROGRAM ALLOWS YOU TO PRINT"
140  PRINT,"PORTIONS OF A SPECIFIED TREE"
142  IFO=6
144  PRINT,"OUTPUT AT TERMINAL "
146  READ,ANS
148  IF(ANS.EQ.NO)IFO = 10
150  WORDS=8
155  IW=0
160  DO 1  K=1,NNOD
170  NOF(K)=LANK
180  NBR(K)=0
190  NOD(K)=0
200  LOC(K)=0
210  LIN(K)=0
220  GTD(K)=0
230  1 CONTINUE
240  MAXLN=0
250  DO 2  K=1,NLEV
260  2 NST(K)=0
270  DO 4  K=1,NLLX
280  DO 3  J=1,NLEV
290  3 LLX(J,K)=0
300  4 CONTINUE
310  DO 6  K=1,NMES
320  MES(9,K)=0
330  DO 5  J=1,WORDS
340  5 MES(J,K)=LANK
350  6 CONTINUE
```

PROGRAM NET1

MAIN CONTROL PROGRAM (continued)

-----  
Powers of 10 are stored in array 'LL' for use in determining the level of a node from the numerical value of its designation. (See subroutine LEVEL.)  
-----

```
360      LL(1)=1
370      DO 8   K=1,6
380      8 LL(K+1)=10**K
```

-----  
The user is asked to enter the name of the tree he wishes to consider. After several counters are set to 0 and scratch file 02 is created, the specified tree is attached as file  
-----

```
390 181 PRINT,"ENTER TREE"
400      READ 182,IW,JW
402 182 FORMAT(A4,A3)
410      PRINT 182,IW,JW
420      PRINT,"OK "
430      READ,ANS
440      IF(ANS.EQ."NO")GO TO 181
450      IFILE(4)=IW
452      IFILE(5)=JW
460      IG=0
470      IN=0
480      MX=0
490      F=0.
500      IH=LANK
510      CALL CREATE(02,1000,0,ISTAT)
520      CALL ATTACH(01,IFILE,1,0,ISTAT,BUFFER)
```

-----  
Input phase. Data for nodes in the first three levels are read. It is from the node designations for the first level nodes that the initial seven characters of the node designations are read. These fields are skipped for the remaining nodes.  
-----

```
530 180 READ (1,411) N1,N2,NM1,NM2,NM3
540 411 FORMAT(2I1,A3,2A2)
550      GO TO 210
560 190 IF (IN-3) 180,191,191
```

-----  
The remaining input is read.  
-----

```
570 191 READ(1,200,END=220)N1,N2,F,IH
580 200 FORMAT(2I1,7X,F5.0,A4)
590 192 IF (N1-9) 210,220,220
```

-----

PROGRAM NET1

MAIN CONTROL PROGRAM (continued)

-----

IN is the index of the node currently being processed. Attributes of this node are stored. For level 8 nodes, the node designation must be computed. (On the input cards a level-8 node is identified by the characters--up to 4--following the decimal point in the node designation. Internal to the program, level 8 nodes follow the same pattern in their designations as the other nodes; for example a level 8 node will have one more integer than its level 7 Parent Node. Thus,

-----

```
600 210 IN=IN+1
610     NBR(IN)=N2
620     IF (N1.EQ.8) F=F*10.+1.
630     NOD(IN)=F
640     NOF(IN)=IH
650     IF (IN-4) 208,208,213
660 208 LS=IN
670     GO TO 218
680 213 CALL LEVEL(LL,NOD(IN),LS)
690 216 IF (LS-N1) 217,218,217
700 217 PRINT 203,N1,LS,NOD(IN)
710 203 FORMAT(1X,6H ERROR ,2I2,I8)
720 218 NST(LS)=NST(LS)+1
```

-----

The texts for all of the nodes are stored in a single array, MES. The location in this array of the first line of text for node IN is stored in the array LOC. One line of text is read, counted, and stored.

-----

```
730     LOC(IN)=IM+1
740 211 READ(1,202,END=220)KODE,II
750 202 FORMAT(A1,8A4)
760 194 LIN(IN)=LIN(IN)+1
770     IM=IM+1
780     IF (IM.GT.1500) GO TO 219
790     DO 212 K=1,WORDS
800 212 MES(K,IM)=II(K)
```

-----

The local variable, KODE, contains the character found in the first column of the text card. The three allowed values and their meanings are:

- (1) blank     There are additional lines of text for this node.
- (2) /         This is the last line of text for this node and there are no GO TO nodes.
- (3) \*         This line specifies a GO TO node.

PROGRAM NET1

MAIN CONTROL PROGRAM (continued)

Any character in the first column of a text card other than blank, /, or \* is treated as a / .

KODE = blank ; reading of the text continues. MAXLN is reset, if necessary.

```
-----  
810     IF (KODE.EQ.LANK) GO TO 211  
820     IF (LIN(IN).GT.MAXLN) MAXLN=LIN(IN)  
-----
```

KODE ≠ blank ; this card must be either the last text card or the first GO TO line. If KODE ≠ \* , this card is the last text card and control must be passed back to statement 190 to read the next node card.

```
-----  
830     IF (KODE.NE.IAS) GO TO 190  
-----
```

KODE = \* ; this is a GO TO line. It is tagged as a GO TO line and counted.

```
-----  
840     MES(9,IM)=1  
850     GTO(IN)=GTO(IN)+1  
-----
```

The next card is read. Now if KODE ≠ \* , the card must be a new node card. It must be written to scratch file ('02') so that it may be reread in the correct format. Control is then returned to statement '192' so that the new node may be processed.

```
-----  
860     READ(1,202) KODE,II  
870     IF (KODE.EQ.IAS) GO TO 194  
880     REWIND 2  
890     WRITE(2,202) KODE,II  
900     REWIND 2  
910     READ(2,200) N1,N2,F,IH  
920     GO TO 192  
-----
```

Reading of the input is ended when the end of file is encountered or when the message file is filled (it has a maximum of 1000 lines as currently dimensioned). The total number of nodes in the tree and the nodes per level are printed.

```
-----  
930 219 PRINT,"MESSAGE FILE TOO LARGE"  
940 220 PRINT 300,IN,(NST(J),J=1,8)  
-----
```

PROGRAM NET1

MAIN CONTROL PROGRAM (continued)

```
950 300 FORMAT(27HINPUT FINISHED NO. NODES = .I4/ 15H NODES/LEVEL : .  
960      8815)
```

---

The next section writes the node designation, number of branches, and number of GO TO's for each node in the tree to scratch file 09. This information may be used in checking new trees. Currently, lines 961-966 are inactive. To reactivate this section, the letter C following the line number must be removed.

---

```
961C CALL CREATE(09,500000,0,ISTAT)  
962C DO 884 K=1,IN  
963C 884 WRITE (9,886)NOD(K),NOF(K),NBR(K),GTO(K)  
964C 886 FORMAT(I7,A4,4(1X,I4))  
965C CALL APRINT(09,"AWC1SS,FRCST 90",9,"RA")  
966C CALL DETACH(09,ISTAT,BUFFER)
```

---

The first three words in array NOD are set to 0. The user is asked to enter the initial node he wishes to consider. He is allowed to enter the full node designation, although the program reads only the four integers following the first seven characters. Any character punched beyond the four integers indicates a level 8 node, whose designation internal to the program must be computed as in the initial data entry.

---

```
970 DO 207 L=1,3  
980 207 NOD(L)=0  
990 223 PRINT 225  
1000 225 FORMAT(1X,18HENTER INITIAL NODE )  
1010 224 READ 226,F,IH  
1020 226 FORMAT(7X,F5.0,A1)  
1030 IF (IH.NE.LANK) F=F*10.+1.  
1040 NODE=F
```

---

The level of the node is determined. (Currently, the initial node may not be in levels 1 or 2.)

---

```
1050 IF (NODE) 400,400,401  
1060 400 LS=3  
1070 GO TO 500  
1080 401 CALL FIND(NODE,NOD,KK)  
1090 IF (KK.NE.999) GO TO 402  
1100 PRINT 227  
1110 227 FORMAT(1X,30HERROR IN NODE. PLEASE RE-ENTER )  
1120 GO TO 224  
1130 402 CALL LEVEL(LL,NODE,LS)
```

---

PROGRAM NET1

MAIN CONTROL PROGRAM (continued)

---

The user is asked to enter his option. His available choices (FOR,BAC,REJ,HEL, and STOP) were stored in array KS, which must be searched to find which he has selected. If his entry cannot be identified, the options are printed and he is given a second chance.

---

```
1140 500 PRINT 601
1150 601 FORMAT(1X,12HENTER OPTION )
1160     READ 502, INS
1170 502 FORMAT(A3)
1180     DO 504 K=1,5
1190     IF (INS.EQ.KS(K)) GO TO 506
1200 504 CONTINUE
1210     GO TO 508
```

---

Program control is transferred to the user's option.

---

```
1220 506 GO TO (510,520,530,999,508),K
```

---

The user has asked for instructions by entering HELP (or HEL, since only the first

---

```
1230 508 PRINT 509
1240 509 FORMAT(10H OPTIONS : /31H FOR - PRINT HIGHER LEVEL NODES /
1250     &31H BACK - PRINT LOWER LEVEL NODES/26HREJ - PRINT REJECTED NODES/
1260     &21H HELP - PRINT OPTIONS / 31H STOP - HALT PROGRAM EXECUTION )
1270     GO TO 500
```

---

The user's print options and their corresponding subroutines are:

FOR- to print forward- Subroutine SF  
BAC- to print back-Subroutine SB  
REF- to print rejected nodes- Subroutine SR

---

PROGRAM NET1

MAIN CONTROL PROGRAM (continued)

---

The subroutine matching the user's option is called. It will store the nodes to be printed in array LLX.

---

```
1280 510 CALL SF(LLX,NEV,NOD,NBR,NODE,LS)
1290      M=0
1300      GO TO 540
1310 520 CALL SB(LLX,NOD,NEV,LS,NODE)
1320      M=1
1330      GO TO 540
1340 530 CALL SR(LLX,NOD,NEV,LS,NODE,NBR)
1350      M=2
```

---

The nodes are printed. First, the temporary output file, 10, is created. Subroutine PRINT is called to write the output to 10. If the output has not already been printed at the terminal, then the AWC-supplied subroutine APRINT is called to print file 10, and the temporary file is detached. Program control is returned to statement 223 to allow the user to enter a new initial node. Note: The location of the CREATE and DETACH commands causes a new set of output (for example, a new job) for each user request. Alternatively, the program could be modified to write all output from a single program execution to file 10 before APRINT is called and the file detached. However, in case of an error in any one of the user requests, no output, even from correct requests, would be produced. The current procedure seems safer.

---

```
1360 540 CALL CREATE(IFQ,500000,0,ISTAT)
1370      CALL PRINT(M)
1375      IF(IFQ.EQ.6)GO TO 550
1380      CALL APRINT(IFQ,"AWCISS,FRCST 90",9,"RA")
1390 550 CALL DETACH(IFQ,ISTAT,BUFFER)
1400      GO TO 223
```

---

The input file 01 and the scratch file 02 are detached. Execution is halted.

---

```
1410 999 CALL DETACH(02,ISTAT,BUFFER)
1420 CALL DETACH(01,ISTAT,BUFFER)
1430 STOP
1440      END
```

---

PROGRAM NET1

SUBROUTINE PRINT(MODE)

Purpose: To print node designations and text for all nodes stored in array LLX. MODG=0; Print Forward; Mode=1, Print Back; Mode 2; print rejected nodes.

```
-----  
1450     SUBROUTINE PRINT(MODE)  
1460     DIMENSION GTO(600),LIN(600),LOC(600),NBR(600),NOD(600),NOF(600),  
1470     8,NEV(8),NST(8),LLX(8,90)  
1480     8,MES(9,1500)  
1490     COMMON GTO,LIN,LOC,NBR,NOD,NOF,MES,NST,LLX,NEV  
1500     8,WORDS,NM1,NM2,NM3,MAXLN,IFO  
1510     DIMENSION ISET(90),IOUT(8,90),JOUT(90,8),KOUT(90,8)  
1520     INTEGER WORDS,GTO  
1530     DATA NO,LANK/2HND,4H     /  
-----
```

This section prints the node designations (without the first 7 characters) of the nodes in of the tree being printed, but lines 1550-1600 may be removed without affecting the major functions of the program.

```
-----  
1540     MZ=0  
1550     WRITE(IFO,38) MODE  
1560     DO 39 K=1,8  
1570     LE=NEV(K)  
1580     WRITE(IFO,38) (LLX(K,J),J=1,LE)  
1590     39 CONTINUE  
1600     38 FORMAT(11I6)  
-----
```

The nodes having to 0.

```
-----  
1540     MZ=0  
1610     DO 50 I=1,50  
1620     50 ISET(I)=0  
1630     IS=0  
-----
```

The node designations stored in LLX are converted to node indices

```
-----  
1640     70 DO 84 I=1,8  
1650     LIM=NEV(I)  
1660     IF (LIM) 84,84,92  
1670     92 IF (I-3) 94,94,82  
1680     94 LLX(I,1)=I  
1690     IOUT(I,1)=I  
1700     GO TO 84  
-----
```

PROGRAM NET1

SUBROUTINE PRINT (continued)

```

1710 82 DO 83 K=1,LIM
1720     CALL FIND(LLX(I,K),NOD,KK)
1730     IF (KK.NE.999) GO TO 78
1740     PRINT 79,LLX(I,K)
1750 79 FORMAT(6H NODE  ,15.10H NOT FOUND )
1760     GO TO 83

```

(NOTE: The nodes in LLX were computed from the initial node and the number of branches in each parent node. If there is an error in the number of branches or if the node has been omitted from the data file, this error message may be printed. Program execution will continue. If the error lies in specifying a value for the number of branches larger than the correct value, the output will be correct. It will, of course, be in error if a node has been omitted. )

```

1770 78 LLX(I,K)=KK
1780     IF (GTO(KK)) 83,83,81
1790 81 IS=IS+1
1800     ISET(IS)=KK
1810     MZ=IS
1820 83 CONTINUE
1830 84 CONTINUE

```

The node indices are transferred to array 'IOUT'. This array is similar to 'LLX' except that blank entries are inserted to provide provide spacing of the output for levels 4 - 8.

```

1840     PRINT,MZ
1850     DO 90 LM=4,8
1860     MAX=NEV(LM)
1870     IF (MAX) 90,90,91
1880 91 IT=0
1890     DO 86 I=1,MAX
1900     IZZ=LLX(LM,I)
1910     IF (IZZ) 86,86,80
1920 80 IT=IT+1
1930     IOUT(LM,IT)=IZZ
1940     IF (MODE) 10,10,86
1950 10 NBB=NBR(IZZ)
1960     IF (NBB-1) 86,86,72
1970 72 DO 74 KK=2,NBB
1980     IT=IT+1
1990 74 IOUT(LM,IT)=0
2000 86 CONTINUE
2010     NEV(LM)=IT
2020 90 CONTINUE

```

PROGRAM NET1

SUBROUTINE PRINT (continued)

-----  
The tree is printed in sections, two levels per section. The major local variables in this section are:

- LVL - Index of the lower level (printed at the left of the page.)
- LVH - Index of the upper level (printed at the right of the page)
- LO - Number of nodes in the lower level
- LH - Number of nodes in the upper level
- L1 - Larger of the two, LO and LH
- NLO - Index of the higher level node to be printed
- NHI - Index of the upper level node to be printed

-----  
2030 DO 130 KZ=1,8,2  
2040 LVL=8-KZ  
2050 LVH=9-KZ  
2060 LH=NEV(LVH)  
2070 LO=NEV(LVL)

NOTE: If LO=0 and LH=0 and this was a print forward, the printing is finished. Otherwise, the section heading is printed.

If the lower level is 1, the node designations are printed at this point.

2080 IF (LO+LH) 95,95,101  
2090 95 IF (MODE) 223,223,130  
2100 101 WRITE(IFQ,111)LVL  
2110 111 FORMAT(//28X,15HNETWORK SECTION ,12/)  
2120 IF (LVL-1) 125,125,128  
2130 125 WRITE(IFQ,901)NM1,NM1,NM2  
2140 901 FORMAT(///1X,A3,36X,A3,A2)

-----  
The output arrays, JOUT (left side) and KOUT (right side), are set to blanks.

-----  
2150 NLO=1  
2160 NHI=2  
2170 128 L7=0  
2180 L8=0  
2190 L1=LH  
2200 IF (LO.GT.LH) L1=LO  
2210 DO 129 K=1,L1  
2220 DO 103 LN=1,MAXLN  
2230 DO 103 LW=1,WORDS  
2240 KOUT(LN,LW)=LANK  
2250 JOUT(LN,LW)=LANK  
2260 103 CONTINUE  
-----

## PROGRAM NET1

## SUBROUTINE PRINT (continued)

-----

The local variables, NLO and NHI, are set to the indices of the lower and upper level nodes next to be printed. If there is no higher level node, then the local variables NFF and NDD are set to blank and 0, respectively. If there is a higher level node, NDD is set to the node designation and NFF to the final alpha characters in the full node designation (blank except for level 8 nodes). If the higher level is level 8, the final integer added to the node designation during the input phase must be removed before printing.

-----

```

2270      IF (LVL.EQ.1) GO TO 108
2280      NLO=IOUT(LVL,K)
2290      NHI=IOUT(LVH,K)
2292      LA=NLO + NHI
2294      LB=K-L1
2296      IF(LA.EQ.0.AND.LB.EQ.0) GO TO 130
2300  29 IF (NHI)  40,40,42
2310  40 NFF=LANK
2320      NDD=0
2330      GO TO 46
2340  42 NFF=NOF(NHI)
2350      NDD=NOD(NHI)
2360  44 IF (LVH.EQ.8) NDD=NDD/10

```

-----

Full node designations are printed.

-----

```

2370  46 IF (LH)  96,96,98
2380  96 WRITE(IFQ,903)NM1,NM2,NM3,NOD(NLO)
2390  903 FORMAT(////1X,A3,2A2,I4)
2400      LB=NHI
2410      GO TO 108
2420  98 IF (NLO)  106,106,104
2430  104 WRITE(IFQ,102)NM1,NM2,NM3,NOD(NLO),NOF(NLO),NM1,NM2,NM3,
2440      &NDD,NFF
2450  102 FORMAT(////1X,A3,2A2,I4,A4,24X,A3,2A2,I4,A4)
2460      GO TO 108
2470  106 WRITE(IFQ,902)NM1,NM2,NM3,NDD,NFF
2480  902 FORMAT(////41X,A3,2A2,I5,A4)

```

-----

For the nodes are transferred to the output arrays, JOUT and KOUT,  
and printed.

-----

## PROGRAM NET1

## SUBROUTINE PRINT (continued)

```

2490 108 IF (NLO-L7) 114,116,114
2500 114 LS7=LOC(NLO)
2510 LE7=LS7+LIN(NLO)-1
2520 LP=0
2530 DO 115 JM=LS7,LE7
2540 LP=LP+1
2550 DO 115 JW=1,WORDS
2560 115 JOUT(LP,JW)=MES(JW,JM)
2570 L7=NLO
2580 116 IF (NHI.EQ.0) GO TO 120
2590 IF (NHI-L8) 118,120,118
2600 118 LS8=LOC(NHI)
2610 LE8=LS8+LIN(NHI)-1
2620 LP=0
2630 DO 119 JM=LS8,LE8
2640 LP=LP+1
2650 DO 119 JW=1,WORDS
2660 119 KOUT(LP,JW)=MES(JW,JM)
2670 L8=NHI
2680 120 DO 122 LZ=1,MAXLN
2690 122 WRITE(IFQ,117)(JOUT(LZ,LX),LX=1,WORDS),(KOUT(LZ,LY),LY=1,WORDS)
2700 117 FORMAT(1X,8A4,4X,8A4)
2710 129 CONTINUE
2720 130 CONTINUE
2730 223 DO 200 I=1,WORDS
2740 DO 200 J=1,50
2750 LLX(I,J)=0
2760 IOUT(I,J)=0
2770 200 CONTINUE

```

If any of the nodes printed had GO TO lines, the user would be given the option of having them printed.

```

2780 IF (MZ) 999,999,899
2790 899 PRINT 905
2800 905 FORMAT(16H LOOK AT GO TO'S )
2810 READ 906,IWS
2820 906 FORMAT(A2)
2830 IF (IWS.EQ.NO) GO TO 999
2840 WRITE(IFQ,907)
2850 907 FORMAT(5H NODE ,10X,5HGO TO )
2860 DO 910 I=1,MZ
2870 J=ISET(I)
2880 LS=LOC(J)
2890 LE=LS+LIN(J)-1

```

PROGRAM NET1

SUBROUTINE PRINT (continued)

```
2900      DO 916 K=LS,LE
2910      IF (MES(9,K)) 916,916,912
2920 912  WRITE(IFO,914)NM1,NM2,NM3,NOD(J),(MES(L,K),L=1,8)
2930 914  FORMAT(1X,A3,2A2,I4,1X,8A4)
2940 916  CONTINUE
2950 910  CONTINUE
```

---

Control is returned to the MAIN CONTROL PROGRAM.

---

```
2960 999 RETURN
2970      END
```

---

PROGRAM NET1

SUBROUTINE SF(LLX,NEV,NOD,NBR,NOD,LS)

Purpose: To identify and store in LLX all higher level nodes directly connected to the initial node, NODE.

LS is the level of NODE and array NEV will contain the number of nodes to be printed in each level.

---

```
2980     SUBROUTINE SF(LLX,NEV,NOD,NBR,NODE,LS)
2990     DIMENSION LLX(8,50),NEV(8),NOD(600),NBR(600)
```

---

The node counter, NEV, is set to 0.

---

```
3000     DO 8 I=1,8
3010     8 NEV(I)=0
```

---

Program control is transferred to instructions for level LS.

---

```
3020     GO TO (10,10,20,30,30,30,70,80),LS
```

---

Levels 1 and 2. (NOTE: Currently, the initial node may not be in levels 1 or 2)

---

```
3030     10 PRINT,"ERROR IN INITIAL NODE LEVEL"
3040     LS=99
3050     GO TO 90
```

---

Levels 3 - 6

---

```
3060     20 LLX(3,1)=0
3070     NEV(3)=1
3080     GO TO 31
3090     30 LLX(LS,1)=NODE
3100     NEV(LS)=1
3110     31 DO 32 I=LS,6
3120     J=I
3130     K=I+1
3140     CALL CHILD(J,K,LLX,NOD,NBR,NEV)
3150     32 CONTINUE
3160     GO TO 75
```

---

PROGRAM NET1

SUBROUTINE SF (continued)

---

Level 7

---

```
3170 70 LLX(7,1)=NODE
3180     NEV(7)=1
3190 75 NG=NEV(7)
3200     NEV(8)=NG
3210     DO 77 K=1,NG
3220 77 LLX(8,K)=LLX(7,K)*10+1
3230     GO TO 90
```

---

Level 8

---

```
3240 80 LLX(8,1)=NODE*10+1
3250     NEV(8)=1
```

---

Control is returned to the MAIN CONTROL PROGRAM

---

```
3260 90 RETURN
3270     END
```

---

PROGRAM NET1

SUBROUTINE SB(LLX,NOD,NEV,LS,NODE)

Purpose: To identify and store in LLX all lower level nodes directly connected to the initial node, NODE.

LS is the level of MODE and array NEV will contain the number of nodes to be printed in each level.

---

```
3280     SUBROUTINE SB(LLX,NOD,NEV,LS,NODE)
3290     DIMENSION LLX(8,50),NOD(600),NEV(8)
```

---

The node counter, NEV, is set to 0. The initial node, NODE, is stored in LLX.

---

```
3300     DO 12 I=1,8
3310     12 NEV(I)=0
3320     2 LLX(LS,1)=NODE
3330     NEV(LS)=1
```

---

The next lower level is computed. If it is above 3, the "parent" node in that level is stored.

---

```
3340     LS=LS-1
3350     IF (LS-4) 20,10,10
3360     10 NODE=NODE/10
3370     GO TO 2
```

---

If the level is 3, then the nodes in levels

---

```
3380     20 DO 22 K=1,3
3390     NEV(K)=1
3400     LLX(K,1)=NOD(K)
3410     22 CONTINUE
```

---

Control is returned to the MAIN CONTROL PROGRAM.

---

```
3420     RETURN
3430     END
```

---

PROGRAM NET1

SUBROUTINE SR(LLX,NOD,NEV,LS,NODE,NBR)

Purpose: To identify and store in LLX all lower levels not directly connected with initial node, NODE, but in the same main branch of the tree.

---

```
3440     SUBROUTINE SR(LLX,NOD,NEV,LS,NODE,NBR)
3450     DIMENSION LLX(8,50),NOD(600),NEV(8)
```

---

The node counter, NEV, is set to 0. The initial node, NODE, is stored in LLX.

---

```
3460     8,NBR(600)
3470     DO 6 I=1,8
3480     6 NEV(I)=0
```

---

The next lower level is computed. If it is above 3, the Parent and Grandparent Nodes are computed.

---

```
3490     NEV(LS)=1
3500     LLX(LS,1)=NODE
3510     9 LP=LS-1
3520     IF (LP-3) 20,20,10
3530     10 NODP=NODE/10
3540     NODG=NODP/10
```

---

If the grandparent Node is 0, its level must be 3; otherwise, subroutine FIND is called to get level K of the grandparent NODG.

---

```
3550     IF (NODG) 30,30,32
3560     30 K=3
3570     GO TO 34
3580     32 CALL FIND(NODG,NOD,K)
```

---

All children of the grandparent Node are stored in LLX.

---

```
3590     34 MX=NBR(K)
3600     DO 12 J=1,MX
3610     12 LLX(LP,J)=NODG*10+J
3620     NEV(LP)=MX
```

---

PROGRAM NET1

SUBROUTINE SR (continued)

---

The next lower level is considered and the steps above repeated until level 3 is reached.

---

```
3630     LS=LP
3640     NODE=NODP
3650     GO TO 9
```

---

When level 3 is reached, no further searching is necessary. Levels 1, 2, and 3 have only one node each. These nodes are stored in LLX.

---

```
3660  20 DO 22  J=1,3
3670     LLX(J,1)=NOD(J)
3680     NEV(J)=1
3690  22 CONTINUE
```

---

Control is returned to the MAIN CONTROL PROGRAM.

---

```
3700     RETURN
3710     END
```

---

PROGRAM NET1

SUBROUTINE CHILD(L1,L2,LLX,NOD,NBR,NEV)

Purpose: To store in LLX all children of those level L1 nodes already  
in LLX.

---

```
3720     SUBROUTINE CHILD(L1,L2,LLX,NOD,NBR,NEV)
3730     DIMENSION LLX(8,50),NOD(600),NBR(600),NEV(8)
```

---

The local variable, LIM, is set to the number of L1 nodes in LLX.  
N will be the counter for the level L2, nodes to be stored.

---

```
3740     LIM=NEV(L1)
3750     N=0
```

---

The index of each node stored in LLX must be found.

---

```
3760     DO 30  I=1,LIM
3770     K=LLX(L1,I)
3780     IF (K) 11,11,12
3790     11 L=3
3800     GO TO 26
3810     12 CALL FIND(K,NOD,L)
```

(NOTE: If the node cannot be found, an error message will be printed at the  
terminal. Execution will continue, but the output for this option will  
not be correct.)

```
3820     IF (L.NE.999) GO TO 26
3830     PRINT 100,L1,K
3840     100 FORMAT(25HERROR IN SUBROUTINE CHILD/5HNODE ,16,5HLEVEL,1X,13,
3850     &39HCANNOT BE FOUND: EXECUTION CONTINUING. )
3860     GO TO 30
```

---

All children of this node are stored in LLX. These steps are repeated for  
all level L1 nodes in LLX. When all nodes have been processed, control is  
returned to subroutine SF.

---

```
3870     26 KK=K*10
3880     MIM=NBR(L)
3890     DO 27  NQ=1,MIM
3900     N=N+1
3910     27 LLX(L2,N)=KK+NQ
3920     NEV(L2)=NEV(L2)+MIM
3930     30 CONTINUE
3940     RETURN
3950     END
```

---

PROGRAM NET1

MINOR UTILITY SUBROUTINES

SUBROUTINE FIND(I,N,K)

Purpose: To find the index K of the node designated by I.

---

```
3960     SUBROUTINE FIND(I,N,K)
3970     DIMENSION N(600)
3980     DO 10  K=1,600
3990     IF (I.EQ.N(K)) GO TO 12
4000  10  CONTINUE
4010     K=999
4020  12  RETURN
4030     END
```

---

SUBROUTINE LEVEL(LL,I,LS)

Purpose: To find the level LS of node I.

---

```
4040     SUBROUTINE LEVEL(LL,I,LS)
4050     DIMENSION LL(7)
```

---

Array LL contains powers of 10 (set in the MAIN PROGRAM). The search for LS is based on the numerical value of the node designation.

---

```
4060     DO 10  J=1,5
4070     LS=6-J
4080     IF (I-LL(LS)) 10,12,12
4090  10  CONTINUE
4100     LS=LS-1
4110  12  LS=LS+3
4120     RETURN
4130     END
```

---

Appendix II: Annotated Program Listings for NET2

PROGRAM NET2

Purpose: To identify and print all groups of equivalent nodes across the entire set of trees.

---

```
10     DIMENSION KON(5),N(5),BUFFER (380),
20     *NN(5010,5),II(5010),LR(5010),LA(5010),IG(5010)
30     INTEGER BL,AS
40     DATA BL,AS/1H ,1H*/
50     DATA KON/1HE,1HM,1HP,1HS,1HT/
```

---

The input file NIF (Node Information File) is attached.

---

```
60     I=0
70     CALL ATTACH (01, "AWCISS/CACI",1,0,ISTAT,BUFFER)
```

---

Input phase. The input file is read. The local variables I1, I2, and I3 (containing actor, action, and target codes, respectively) are packed into a single word. The other node descriptors are stored.

---

```
80     1 READ (1,100,END=50) N,I1,I2,I3,I4,I5
90     100 FORMAT(3A1,2A4,1X,I3,3X,I2,1X,I3,3X,I1,I2)
100     IF (N(1).EQ.AS) GO TO 50
110     K=I1*100000+I2*1000+I3
120     I=I+1
130     IF (I.GT.5010) GO TO 50
140     II(I)=K
150     LR(I)=I4
160     LA(I)=I5
170     DO 8 M=1,5
180     8 NN(I,M)=N(M)
```

---

The equivalence group for the node is determined. Either it is equivalent to a previous node, or its descriptors form the basis of a new group.

---

PROGRAM NET2 (continued)

```
-----  
190      IF (I-1) 10,10,20  
200     10 IG(I)=1  
210      LG=1  
220      GO TO 1  
230     20 KFND=I-1  
240      DO 28 M=1,KEND  
250      IF (II(M)-K) 28,24,28  
260     24 IF (LA(M).EQ.LA(I).AND.LR(M).EQ.LR(I)) GO TO 30  
270     28 CONTINUE  
280      LG=LG+1  
290      IG(I)=LG  
300      GO TO 1  
310     30 IG(I)=IG(M)  
320      GO TO 1  
-----
```

The input file has been read; the number of records and groups are printed.

```
-----  
330     50 NR=I  
340      PRINT 101,NR,LG  
350     101 FORMAT(" INPUT COMPLETE ",I5," RECORDS ",I5," GROUPS")  
-----
```

For each tree type; E,M,P,S, and T

```
-----  
360      DO 60 I=1,5  
370      WRITE (9,102) KON(I)  
380     102 FORMAT(1H1," EQUIVALENT NODES FOR ",A1," TRES")  
390      DO 58 J=1,NR  
400      DO 52 IJ=1,3  
410      IF (NN(J,IJ).NE.BL) GO TO 53  
420     52 CONTINUE  
430      GO TO 58  
440     53 IF (NN(J,IJ).NE.KON(I)) GO TO 58  
450      LGX=IG(J)  
-----
```

Print each node belonging to it ...

```
-----  
460      WRITE(9,103) (NN(J,KA),KA=1,5),II(J),LR(J),LA(J)  
470     103 FORMAT(1H ,4HNODE,1X,3A1,2A4,4X,16HEQUIVALENT NODES  
480      83X,110,2(1X,I3))  
-----
```

...and each member in its equivalence group.

PROGRAM NET2 (continued)

---

```
490      DO 56  JJ=1,NR
500      IF (IG(JJ).NE.LGX)  GO TO 56
510      IF (J-JJ)  54,56,54
520      54 WRITE (9,104) (NN(JJ,KA),KA=1,5),II(JJ),LR(JJ),LA(JJ)
530      104 FORMAT(24X,3A1,2A4,5X,I10,2(1X,I3))
540      56 CONTINUE
550      58 CONTINUE
560      WRITE(9,105) KON(I)
570      105 FORMAT(2X,"END OF EQUIVALENT NODES FOR ".A1," TREE"/)
580      60 CONTINUE
```

---

The printing is finished.

---

```
604      PRINT 605
620      605 FORMAT(" RUN FINISHED")
```

---

PROGRAM execution is ended.

---

```
610      STOP
620      END
```

---

Appendix III: Annotated Program Listing for NET3

PROGRAM NET3

Purpose: To select and print nodes from the Node Information File (NIF).

MAIN CONTROL PROGRAM

Purpose: To identify user requests and to read the file and print selected nodes.

```
-----  
10     DIMENSION IWORD(5),IN(5),N(3),BUFFER(380)  
20     *,KN(5),NS(3)  
30     INTEGER BL,ALL  
40     DATA BL,NO,IO,IH,ALL/IH ,IHN,IHO,IHH,IHA/  
50     DATA IWORD/3HATR,3HACT,3HTAR,3HREG,3HSUB/  
-----
```

The input file, NIF is attached. Statement 100 is the format by which the file will be read.

```
-----  
65     CALL ATTACH(01,"AWCISS/CACI/NIF;",1,0,ISTAT,BUFFER)  
80     100 FORMAT(3A4,I3,3X,I2,1X,I3,3X,I1,I2)  
190    101 FORMAT(1X,14HNO. RECORDS = ,I6)  
-----
```

The next section solicits and reads the user's instructions. His selection options are stored in IWORD: he may select nodes with a specific actor, action, target, region, or substantive area. As each option is presented, he enters either a specific code or the word ALL, indicating that he does not wish to select nodes by this variable. A request for help at the beginning will result in printing his options (see format statement 105, line 310). Entering the word HELP in response to requests for codes will cause the program to print the name of the variable for which a code is requested. The word OUT entered at any point will cause the HELP option to be deactivated.

```
-----  
200    18 PRINT 102  
210    102 FORMAT(1X,11HWANT HELP )  
220    20 READ 103,INS  
230    103 FORMAT(3A1)  
240    IF (INS.EO.NO) GO TO 22  
250    IF (INS.NE.BL) GO TO 21  
260    PRINT 104  
270    104 FORMAT(1X,69HMISSED YOUR ANSWER. PLEASE RE-ENTER IT. ST  
280    &HE FIRST COLUMN. )  
290    GO TO 20  
-----
```

ARTING IN T

PROGRAM NET3 (continued)

```

300 21 PRINT 105
310 105 FORMAT(70H YOU MAY SELECT NODES BY ONE OR MORE OF THE FOLLOWING
320 8DE ATTRIBUTES: /11H ACTOR(ATR) /9H ACT(ACT) / 12H TARGET(TA
330 822H SUBSTANTIVE AREA(SUB) / 12H REGION(REG) /      ING NO
340 843H EACH ATTRIBUTE WILL BE CONSIDERED IN TURN / R) /
350 832H ENTER A SPECIFIC CODE OR 'ALL' /
360 8" ENTER CODES AS 3-DIGIT INTEGERS; I.E. ACTOR '2' AS '002' /
370 8 REGION '3' AS '003'"/
372 8" TO REQUEST HELP AT ANY STAGE, ENTER 'HELP'"/
380 828H TO CANCEL HELP, ENTER 'OUT' )
390 22 DO 40 J=1,5
400 IF (INS.EQ.NO) GO TO 25
410 24 PRINT 106,IWORD(J)
420 106 FORMAT(12H SELECT ONE ,A3)
430 25 READ 103,NS
440 IF (NS(1).EQ.ALL) GO TO 30
450 IF (NS(1).EQ. IO) GO TO 28
460 IF (NS(1).EQ. IH) GO TO 27
470 26 CALL CONV(NS,KI)
490 IF (KI.EQ.9999) GO TO 24
490 IN(J)=KI
500 GO TO 40
510 27 INS=BL
520 GO TO 24
530 28 INS=NO
540 GO TO 25
550 30 IN(J)=-1
560 40 CONTINUE

```

-----

The user-selected codes are stored in the array, IN. When the user input is complete, this array is printed as a check. A value of -1 for any word in this array indicates that the corresponding variable will not be used in selecting nodes to be printed (for example, all values of this variable will be accepted).

```

570 PRINT 200,IN
590 200 FORMAT(5I4)

```

-----

The counter, ITOT, is set to 0 and the input file is rewound. As each file record is read, it is compared with the set of selection codes in IN; all matches are printed.

```

590 ITOT=0
600 REWIND 1
605 1 READ(1,100,END=50) N,KN

```

PROGRAM NET3 (continued)

```
610      DO 48 J=1,5
620      IF (IN(J)) 48,42 ,42
630      42 IF (KN(J).NE.IN(J)) GO TO 1
640      4R CONTINUE
650      ITOT=ITOT+1
660      PRINT 100,N,KN
670      GO TO 1
```

---

When the reading of the file is finished, the number of matches is printed and the user is given a chance to make another search through the file. If his answer is NO, the input file is detached and program execution is terminated.

---

```
690      50 PRINT 108,ITOT
700      108 FORMAT(/I6,1X,7HMATCHES// 21H ADDITIONAL SEARCHES )
710      READ 103,INS
720      IF (INS.NE.NO) GO TO 18
725      CALL DETACH(01,ISTAT,BUFFER)
730      STOP
740      END
```

---

PROGRAM NET3

SUBROUTINE CONV(N,KI)

Purpose: To convert the 3-character alpha variable, N, into a 3-digit integer, KI.

---

```
750     SUBROUTINE CONV(N,KI)
760         DIMENSION NUM(10),N(3),L(3)
770         DATA NUM/1H1,1H2,1H3,1H4,1H5,1H6,1H7,1H8,1H9,1H0/
780         DATA L/100,10,1/
```

---

Each character in N is compared with the list of integers in array NUM to find a match. If there is an error, a message is printed.

---

```
790         KI=0
800         DO 20 K=1,3
810             DO 10 J=1,10
820                 IF (N(K).EQ.NUM(J)) GO TO 12
830             10 CONTINUE
840             PRINT 100,N
850         100 FORMAT(1X,9HERROR IN ,3A1)
860             KI=9999
870             GO TO 99
```

---

The 3-digit integer is constructed from powers of 10 and the match J.

---

```
880     12 IF (J.EQ.10) J=0
890         KI=KI+J*L(K)
900     20 CONTINUE
```

---

Control is transferred back to the MAIN CONTROL PROGRAM.

---

```
930     99 RETURN
940         END
```

---

Appendix IV: Annotated Program Listing for NET4

PROGRAM NET4

Purpose: To modify and update the Tree Summary File (TSF); to retrieve information from the file for specific trees.

MAIN PROGRAM

Purpose: To read the TSF and to execute user instructions.

```
-----  
10     DIMENSION II(29),JCODE(7)  
20     DIMENSION IX(60,29),IS(7),KS(7),BUFFER(380)  
22 DATA IS/3HHEL,3HALL,3HMOD,3HADD,3HDIS,3HEND,3HSTO/  
30     DATA KS/3HAUT,3HDTC,3HDTM,3HACT,3HSUB,3HREG,3HTRE/  
40     DATA NO,LANK/2HNO,4H      /  
50     DATA NC,NS,NN,NV/7,7,60,29/  
-----
```

The TSF is located and read. (It is stored in the AWC system under the name DNET4.)

```
-----  
55     CALL ATTACH(01,"AWCISS/CACI/DNET4;",1,0,ISTAT,BUFFER)  
60     NUM=0  
70     I=0  
80     1 I=I+1  
90     IF (I.GT.NN) GO TO 4  
100    READ(1,100,END=4) (IX(I,J),J=1,NV)  
110    100 FORMAT(2A4,1X,A4,1X,2(I6,1X),I3,1X,A3,2(1X,A2)/20A4)  
120    IF (IX(I,1).NE.LANK) GO TO 1  
130    4 NR=I-1  
140    PRINT 102,NR  
150    102 FORMAT(16H INPUT COMPLETE ,I4,14H RECORDS READ )  
-----
```

The user's option is read and control transferred to the appropriate program instruction.

```
-----  
160    6 PRINT 104  
170    104 FORMAT(13H ENTER OPTION )  
180    READ 105,INS  
190    105 FORMAT(A3)  
200    DO 8 I=1,NC  
210    IF (INS.EQ.IS(I)) GO TO 9  
220    8 CONTINUE  
230    GO TO 10  
240    9 GO TO (10,20,30,40,50,60,70),I  
-----
```

PROGRAM NET4 (continued)

-----  
The user has requested help; the program options are printed.  
-----

```
250 10 PRINT 106
260 106 FORMAT(38H THE FOLLOWING OPTIONS ARE AVAILABLE: /
270      &34H HELP - TO PRINT USER INSTRUCTIONS /
280      &28H ALL - TO PRINT ENTIRE FILE /
290      &33H MOD - TO MODIFY LAST CHANGE DATE /
300      &29H ADD - TO ADD ENTRIES TO FILE /
310      &40H DIS - TO DISPLAY SELECTED FILE ENTRIES /
320      &33H STOP - TO STOP PROGRAM EXECUTION )
330      GO TO 6
```

-----  
The user has requested that the entire file be printed.  
-----

```
340 20 DO 22 J=1,NR
350 22 PRINT 100,(IX(J,K),K=1,NV)
360 108 FORMAT(I3,1X,A4,1X,2A4,1X,2(I6,1X),I3,1X,A3,2(1X,A2)/20A4)
370      GO TO 6
```

-----  
The last modification date of a specific tree is to be updated; The user indicates the tree name and the new date.  
-----

```
380 30 PRINT 110
390 110 FORMAT(12H TREE NAME )
400      READ 100,IA,IB
402      IF (IA.NE.IS(1)) GO TO 31
404      PRINT,"TREE NAMES CONSIST OF 7 CHARACTERS; FOR EXAMPLE: T010101"
406      GO TO 6
410 31 DO 32 J=1,NR
420      IF (IA.EQ.IX(J,1).AND.IB.EQ.IX(J,2)) GO TO 34
430 32 CONTINUE
440      PRINT 114,IA,IB
450 114 FORMAT(10H ERROR IN ,2A4)
460      GO TO 30
470 34 PRINT 115
480 115 FORMAT(22H DATE OF LAST CHANGE )
490      READ 116,IDT
500 116 FORMAT(I6)
```

-----  
The user's instructions are rechecked. Upon his OK, the new date is written into the file.  
-----

```
510      PRINT 118,IX(J,4),IDT
520 118 FORMAT(10H OLD DATE ,I6,19H TO BE REPLACED BY ,I6)
```

PROGRAM NET4 (continued)

ACT- to select entries by actor  
AUT- to select entries by author  
DFC- to select file entries by file creation date  
DFM- to select entries by the date of last modification  
SUB- to select entries by substantive area  
REG- to select entries by region

---

```
800 50 DO 51 K=1,NS
810 51 JCODE(K)=LANK
820 52 PRINT 130
830 130 FORMAT(23H ENTER SELECTION OPTION )
840 READ 105,INS
850 IF (INS.EQ.NO) GO TO 57
860 IF (INS.EQ.IS(1)) GO TO 59
870 IF (INS.EQ.IS(6)) GO TO 6
880 IF (INS.EQ.IS(7)) GO TO 70
890 DO 53 J=1,NS
900 IF (INS.EQ.KS(J)) GO TO 54
910 53 CONTINUE
920 PRINT 114,INS
930 GO TO 59
940 54 IF (J.NE.NS) GO TO 55
```

---

The user wishes to print information on a specific tree. He is asked to enter the name of the tree. If the tree is in the file, the entry is printed.

---

```
950 PRINT 110
960 READ 100,IA,IB
970 DO 502 J=1,NR
980 IF (IA.NE.IX(J,1)) GO TO 502
990 IF (IB.NE.IX(J,2)) GO TO 502
1000 PRINT 100,(IX(J,K),K=1,NV)
1010 GO TO 50
1020 502 CONTINUE
1030 PRINT 114,IA,IB
1040 GO TO 52
```

---

The user has indicated one of the specific entry attributes: author, date, actor, substantive area, or region. Program control is transferred to the proper instruction to read the specific code for the attribute selected. The code entered by the user is stored in the selection code array, may end this section by entering the word NO.

---

```
1050 55 GO TO (510,520,520,540,550,560),J
```

PROGRAM NET4 (continued)

```
530     PRINT 120
540 120  FORMAT(5H OK )
550     READ 122,INS
560 122  FORMAT(A2)
570     IF (INS.EQ.NO) GO TO 30
580     IX(J,4)=IDT
590     NUM=NUM+1
600     GO TO 6
```

---

The user wishes to add an entry to the file. If the file is full, he is instructed to increase the array dimensions before adding new entries. After his new entry has been typed, he is given the opportunity of checking it against the last entry in the old file. If he is satisfied that the lines are correct, they are added to the file.

---

```
610 40  IF (NR-NN) 41,48,48
620 41  PRINT 124
630 124  FORMAT(15H ENTER NEW LINE )
640     READ 100,II
650     PRINT 126
660 126  FORMAT(20H LAST TWO LINES ARE: )
670     PRINT 100,(IX(NR,K),K=1,NV)
680     PRINT 100,II
690     PRINT 120
700     READ 122,INS
710     IF (INS.EQ.NO) GO TO 40
720     NR=NR+1
730     DO 42 J=1,NV
740 42  IX(NR,J)=II(J)
750     NUM=NUM+1
760     GO TO 40
770 48  PRINT 128
780 128  FORMAT(40H FILE FULL. DIMENSIONS MUST BE INCREASED )
790     GO TO 6
```

---

The user wishes to display selected portions of the file. He is instructed to enter his selection option. His choices at this point are:

- NO- to indicate that he has completed the selection code array and wishes the matching entries to be printed,
- HELP- to print the list of options
- STOP- to terminate program execution
- TREE- to print the entry for a specific tree

PROGRAM NET4 (conitnued)

```
1060 510 PRINT 134
1070 134 FORMAT(13H ENTER AUTHOR )
1080     READ 112,JCODE(1)
1085 112 FORMAT(A4)
1090     GO TO 52
1100 520 PRINT 136
1110 136 FORMAT(20H ENTER EARLIEST DATE )
1120     READ 116,JCODE(J)
1130     GO TO 52
1140 540 PRINT 137
1150 137 FORMAT(12H ENTER ACTOR )
1160 READ 105,JCODE(4)
1162 GO TO 52
1170 550 PRINT 138
1180 138 FORMAT(23H ENTER SUBSTANTIVE AREA )
1190 READ 122,JCODE(5)
1192 GO TO 52
1200 560 PRINT 140
1210 140 FORMAT(13H ENTER REGION )
1220 READ 122,JCODE(6)
1230     GO TO 52
```

---

All selection options have been read. The file is searched and all entries matching the selected codes are printed.

---

```
1240 57 ITOT=0
1250     DO 574 J=1,NR
1260     IF (JCODE(1).EQ.LANK) GO TO 571
1264     IF (IX(J,3).NE.JCODE(1)) GO TO 574
1266 571 IF (JCODE(2).EQ.LANK) GO TO 572
1270     IF (IX(J,4).LT.JCODE(2)) GO TO 574
1272 572 IF (JCODE(3).EQ.LANK) GO TO 575
1274     IF (IX(J,5).LT.JCODE(3)) GO TO 574
1276 575 IF (JCODE(4).EQ.LANK) GO TO 576
1278     IF (IX(J,7).NE.JCODE(4)) GO TO 574
1280 576 IF (JCODE(5).EQ.LANK) GO TO 577
1282     IF (IX(J,8).NE.JCODE(5)) GO TO 574
1286 577 IF (JCODE(6).EQ.LANK) GO TO 578
1288     IF (IX(J,9).NE.JCODE(6)) GO TO 574
1290 578 ITOT=ITOT+1
1300     PRINT 100,(IX(J,L),L=1,NV)
1310 574 CONTINUE
1320     PRINT 142,ITOT
1330 142 FORMAT(1X,I3,8H MATCHES )
1340     GO TO 50
```

---

PROGRAM NET4 (conitnued)

-----  
The user has requested help; the selection options are printed.

-----  
1350 59 PRINT 144  
1360 144 FORMAT(" SELECTION OPTIONS ARE:" / " TREE - TREE NAME " /  
1370 &15H AUTH - AUTHOR / 20H DTC - DATE CREATED /  
1380 &" DTM - DATE MODIFIED" / "A ACT - ACTOR" /  
1390 &15H SUB - SUB-AREA / 13H REG - REGION /  
1400 &28H END - TO END CURRENT OPTION )  
1410 GO TO 50  
-----

The user has entered the instruction to END. To avoid confusion over whether he meant to end the current option or to end the program, he is given an opportunity to recheck his instruction. Upon his OK, program control is transferred to the ending sequence.

-----  
1420 60 PRINT 146  
1430 146 FORMAT(10H END NOW )  
1440 READ 105,INS  
1450 IF (INS.NE.NO) GO TO 6  
-----

If the file has been modified, the user is asked to indicate whether or not he wishes the modified file to be saved.

-----  
1460 70 IF (NUM) 80,80,72  
1470 72 PRINT 148,NUM  
1480 148 FORMAT(13,38H MODIFICATION(S). SAVE MODIFIED FILE )  
1490 READ 105,INS  
1500 IF (INS.EQ.NO) GO TO 80  
1510 REWIND 1  
1518 DO 78 I=1,NR  
1520 WRITE(1,100) (IX(I,J),J=1,NV)  
1522 78 CONTINUE  
1530 PRINT 150  
1540 150 FORMAT(11H FILE SAVED )  
-----

The input file is released and program execution is terminated.

-----  
1550 80 CALL DETACH(01,ISTAT,BUFFER)  
1560 STOP  
1570 END  
-----

Appendix V: Listing of FORECAST 90 Files

CATALOG NAME FILE NAME	SCC	GEN'L DEVICE PERMS TYP:NAME	CREATE DATE	DATE OF LAST MODIFY ALLOC CHANGE	TIME	MAX CURRENT LLINKS	LAST SAVE VOL-CHG?	ALLOC CNT	FILE STAT TYPE
CACI									
NET1	UNC	190:ST1	062075 062075	071875 071875	09.593	50	13 09323N	154	SEO
		PERMISSIONS: R/WAWC-DS/. W/AWC-DS/							
NET2	UNC	190:DP2	062075 062075	071275 070875	10.502	50	13 09323N	11	SEO
NET3	UNC	190:DP2	062075 062075	080175 070375	12.453	50	13 09323N	14	SEO
NET4	UNC	190:DP2	062075 062075	080575 070175	20.008	50	13 09323N	18	SEO
DNET4	UNC	190:ST1	062075 062075	080575 071675	10.475	50	13 09323N	18	SEO
E010201	UNC	190:DP2	071275 071275	071875 071575	18.386	520	26 09323N	4	SEO
E010104	UNC	190:DP2	071275 071275	071575 071575	18.386	520	26 09323N	2	SEO
S010401	UNC	190:DP2	071275 071275	071575 071575	18.386	520	26 09323N	2	SFO
P010501	UNC	190:DP2	071275 071275	071575 071575	18.511	520	26 09323N	3	SEO
S010501	UNC	190:DP2	071275 071275	071575 071575	18.511	520	26 09323N	2	SEO
E010102	UNC	190:DP2	071275 071275	071675 071675	09.348	520	26 09323N	4	SEO
E010301	UNC	190:DP2	071275 071275	071675 071575	17.333	520	26 09323N	7	SEO
E010302	UNC	190:ST1	071275 071275	071575 071575	18.512	520	26 09323N	4	SEO
T010201	UNC	190:DP2	071275 071275	071575 071575	15.567	600	30 09323N	8	SEO
M010401	UNC	190:ST1	071275 071275	071275 071275	15.651	520	26 09323N	3	SEO
E010101	UNC	190:ST1	071275 071275	080575 071575	18.334	520	26 09323N	4	SEO
P010R02	UNC	190:DP2	071275 071275	071575 071575	18.334	520	26 09323N	2	SEO
E010103	UNC	190:DP2	071275 071275	071575 071575	18.334	520	26 09323N	2	SEO
P010601	UNC	190:ST1	071275 071275	071575 071575	18.334	520	26 09323N	2	SEO
BNET1	UNC	190:DP2	071275 071275	071275 071275	15.501	240	144 09323N	2	SEO
NIF	UNC	190:DP2	070375 070375	080175 070375	11.612	250	241 09323N	12	SEO
M010101	UNC	190:DP2	071275 071275	071575 071575	18.335	520	26 09323N	2	SEO
T010202	UNC	190:DP2	071275 071275	071575 071575	18.335	520	26 09323N	3	SEO
T010101	UNC	190:DP2	071275 071275	071575 071575	18.335	520	29 09323N	2	SEO
T010203	UNC	190:DP2	071275 071275	071575 071575	18.335	520	26 09323N	2	SEO
T010602	UNC	190:DP2	071275 071275	071675 071675	09.582	520	26 09323N	4	SEO
E010401	UNC	190:DP2	071575 071575	071575 071575	13.177	260	13 09323N	4	SEO
E010501	UNC	190:ST1	071575 071575	071575 071575	13.270	180	9 09323N	1	SEO
M010201	UNC	190:ST1	071575 071575	071575 071575	13.271	300	15 09323N	1	SEO
M010301	UNC	190:ST1	071575 071575	071575 071575	13.311	120	6 09323N	1	SEO
M010302	UNC	190:ST1	071575 071575	071575 071575	13.311	380	19 09323N	1	SEO
M010303	UNC	190:ST1	071575 071575	071575 071575	13.312	320	16 09323N	1	SEO
M010304	UNC	190:DP2	071575 071575	071575 071575	14.102	200	10 09323N	2	SEO
M010305	UNC	190:DP2	071575 071575	071575 071575	14.102	160	8 09323N	2	SEO
P010301	UNC	190:DP2	071575 071575	071575 071575	17.021	340	17 09323N	9	SEO
M010306	UNC	190:DP2	071575 071575	071575 071575	15.450	220	11 09323N	2	SEO
M010307	UNC	190:DP2	071575 071575	071575 071575	15.450	140	7 09323N	1	SEO
M010402	UNC	190:DP2	071575 071575	071575 071575	15.450	280	14 09323N	1	SEO
M010403	UNC	190:DP2	071575 071575	071575 071575	15.501	240	12 09323N	2	SEO

CATALOG NAME FILE NAME	SEC	GEN'L DEVICE PERMS TYP:NAME	CREATE DATE	MODIFY DATE	DATE OF LAST ALLOC CHANGE	TIME	MAX LLINKS	CURRENT LLINKS	LAST VOL-CHG?	SAVE CNT	ALLOC STAT	FILE TYPE
M010404	UNC	190:DP2	071575	071575	071575	15.501	280	14	09323N	2		SEO
M010501	UNC	190:ST1	071575	071575	071575	17.772	400	20	09323N	3		SEO
M010502	UNC	190:ST1	071575	071575	071575	17.855	220	11	09323N	1		SEO
M010601	UNC	190:DP2	071575	071675	071675	10.176	260	13	09323N	4		SEO
M010602	UNC	190:ST1	071575	071575	071575	17.855	180	9	09323N	2		SEO
P010101	UNC	190:DP2	071575	071575	071575	17.918	460	23	09323N	2		SEO
P010102	UNC	190:DP2	071575	071575	071575	17.947	480	24	09323N	1		SEO
P010201	UNC	190:DP2	071575	071575	071575	17.947	260	13	09323N	1		SEO
P010302	UNC	190:DP2	071575	071575	071575	17.998	380	19	09323N	1		SEO
P010303	UNC	190:DP2	071575	071575	071575	17.998	220	11	09323N	1		SEO
P010401	UNC	190:DP2	071575	071575	071575	18.037	740	37	09323N	1		SEO
P010701	UNC	190:DP2	071575	071575	071575	18.037	420	21	09323N	1		SEO
P010801	UNC	190:DP2	071575	071575	071575	18.118	160	8	09323N	1		SEO
P010901	UNC	190:DP2	071575	071575	071575	18.082	1280	64	09323N	3		SEO
S010502	UNC	190:DP2	071575	071575	071575	18.149	320	16	09323N	1		SEO
S010601	UNC	190:DP2	071575	071575	071575	18.149	380	19	09323N	1		SEO
S010701	UNC	190:DP2	071575	071575	071575	18.191	380	19	09323N	1		SEO
T010501	UNC	190:DP2	071575	071575	071575	18.191	400	20	09323N	1		SEO
T010601	UNC	190:DP2	071575	071575	071575	18.191	280	14	09323N	1		SEO
S010101	UNC	190:DP2	071575	071575	071575	18.436	380	19	09323N	2		SEO

TE  
MED

82