

AD-A115 850

DAYTON UNIV OH RESEARCH INST

F/6 11/3

RAIN EROSION EVALUATION AND ANALYSIS OF SELECTED COATED MONOLIT--ETC(U)

MAY 82 C J MURLEY, J ZAHAVI, G F SCHMITT

F33615-78-C-5127

UNCLASSIFIED

AFWAL-TR-82-8029

NL

1 of 2 pages

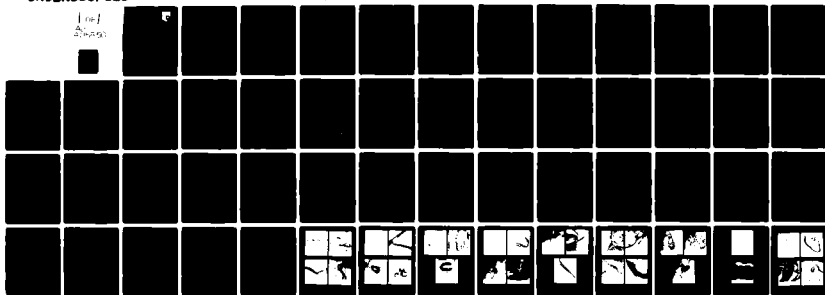

END
DATE
FILMED
7-82
DTIC

AD A115850

AFWAL-TR-82-4029

RAIN EROSION EVALUATION AND ANALYSIS OF
SELECTED COATED MONOLITHIC POLYCARBONATE
TRANSPARENCY MATERIALS



Charles J. Hurley
University of Dayton Research Institute

Joseph Zahavi
Israel Institute of Metals, Technion

George F. Schmitt
Air Force Wright Aeronautical Laboratories

May 1982

Final Report for Period July 1980 - December 1981

Approved for public release; distribution unlimited.

DTIC FILE COPY

MATERIALS LABORATORY
AIR FORCE WRIGHT AERONAUTICAL LABORATORIES
AIR FORCE SYSTEMS COMMAND
WRIGHT-PATTERSON AIR FORCE BASE, OHIO 45431

DTIC
ELECTE
JUN 21 1982

NOTICE

When Government drawings, specifications, or other data are used for any purpose other than in connection with a definitely related Government procurement operation, the United States Government thereby incurs no responsibility nor any obligation whatsoever; and the fact that the Government may have formulated, furnished, or in any way supplied the said drawings, specifications, or other data, is not to be regarded by implication or otherwise as in any manner licensing the holder or any other person or corporation, or conveying any rights or permission to manufacture, use, or sell any patented invention that may in any way be related thereto.

This report has been reviewed by the Office of Public Affairs (ASD/PA) and is releasable to the National Technical Information Service (NTIS). At NTIS, it will be available to the general public, including foreign nations.

This technical report has been reviewed and is approved for publication.



G. F. SCHMITT
Project Engineer

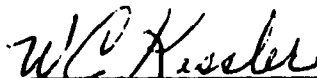

W. C. KESSLER, Chief
Coatings & Thermal Protective
Materials Branch

FOR THE COMMANDER



F. D. CHERRY, Chief
Nonmetallic Materials Division

"If your address has changed, if you wish to be removed from our mailing list, or if the addressee is no longer employed by your organization, please notify AFWAL/MLBE, WPAFB, OH 45433 to help us maintain a current mailing list."

Copies of this report should not be returned unless return is required by security considerations, contractual obligations, or notice on a specific document.

UNCLASSIFIED

SECURITY CLASSIFICATION OF THIS PAGE (When Data Entered)

REPORT DOCUMENTATION PAGE		READ INSTRUCTIONS BEFORE COMPLETING FORM
1. REPORT NUMBER AFWAL-TR-82-4029	2. GOVT ACCESSION NO. A1530	3. RECIPIENT'S CATALOG NUMBER
4. TITLE (and Subtitle) RAIN EROSION EVALUATION AND ANALYSIS OF SELECTED COATED MONOLITHIC POLYCARBONATE TRANSPARENCY MATERIALS		5. TYPE OF REPORT & PERIOD COVERED Final Report July 1980 - December 1981
		6. PERFORMING ORG. REPORT NUMBER
7. AUTHOR(s) Charles J. Hurley, Joseph Zahavi, and George F. Schmitt		8. CONTRACT OR GRANT NUMBER(s) F33615-78-C-5127 F33615-79-C-5129-
9. PERFORMING ORGANIZATION NAME AND ADDRESS University of Dayton Research Institute 300 College Park Avenue Dayton, Ohio 45469		10. PROGRAM ELEMENT, PROJECT, TASK AREA & WORK UNIT NUMBERS 24220101
11. CONTROLLING OFFICE NAME AND ADDRESS Materials Laboratory (AFWAL/MLBE) Air Force Systems Command Wright-Patterson Air Force Base, OH 45433		12. REPORT DATE May 1982
		13. NUMBER OF PAGES 54
14. MONITORING AGENCY NAME & ADDRESS (if different from Controlling Office)		15. SECURITY CLASS. (of this report) Unclassified
		15a. DECLASSIFICATION/DOWNGRADING SCHEDULE
16. DISTRIBUTION STATEMENT (of this Report) Approved for public release; distribution unlimited.		
17. DISTRIBUTION STATEMENT (of the abstract entered in Block 20, if different from Report)		
18. SUPPLEMENTARY NOTES Prepared in cooperation with: Israel Institute of Metals, Technion, Haifa (Israel) and Materials Laboratory (AFWAL/MLBE), WPAFB, Ohio 45433		
19. KEY WORDS (Continue on reverse side if necessary and identify by block number) polycarbonate coated polycarbonate aircraft transparency rain erosion test and evaluation		
20. ABSTRACT (Continue on reverse side if necessary and identify by block number) This report documents a test program which was conducted to evaluate the rain erosion resistance of selected coated monolithic polycarbonate materials after being subjected to accelerated ultraviolet exposure and to evaluate the effect of exposure duration at 500 mph in a 1 inch/hour rainfall. Tests included: weight loss, haze measurements, percent coating removal and SEM examinations.		

DD FORM 1473
1 JAN 73

EDITION OF 1 NOV 65 IS OBSOLETE

UNCLASSIFIED
SECURITY CLASSIFICATION OF THIS PAGE (When Data Entered)

PREFACE

The effort documented in this report was conducted as a joint enterprise by the following persons: Charles J. Hurley, University of Dayton Research Institute, under Contract No. F33615-78-C-5127; Dr. Joseph Zahavi, Visiting Scientist, under Contract No. F33615-79-C-5129 with Universal Energy Systems, Inc.; and George F. Schmitt, Air Force Wright Aeronautical Laboratories, Materials Laboratory, under Project No. 2422, Task No. 242201. The work described herein was conducted during the period from July 1980 to December 1981.

The authors wish to acknowledge the contributions of Timothy Courney and James Gannon of the University of Dayton Research Institute for performing the rain exposure tests. Appreciation is also extended to Rick Bacon and Robert Brodecki of Systems Research Laboratories for the SEM operations and photography, and to Kenneth Clayton and John Milholland of the University of Dayton Research Institute for providing the test specimens.



TABLE OF CONTENTS

Section	Page
I INTRODUCTION	1
1. BACKGROUND	1
2. OBJECTIVE	1
II EXPERIMENTAL PROCEDURE	2
1. MATERIALS	2
2. TEST SPECIMEN FABRICATION	2
3. ULTRAVIOLET RADIATION ENVIRONMENTAL CONDITIONING	4
a. Accelerated UV Laboratory Conditioning	4
b. Accelerated Outdoor Sunshine Conditioning	5
4. TEST SPECIMEN PRETEST EXAMINATION	5
5. MACH 1.2 RAIN EROSION TEST APPARATUS	5
6. POST-TEST OBSERVATION AND EXAMINATION PROCEDURES	7
a. Visual Observation	7
b. Scanning Electron Microscopy Examination	7
c. Hazemeter Measurements	7
III TEST RESULTS	8
1. RAIN EROSION TEST RESULTS - VISUAL EXAMINATION	8
a. No Accelerated UV Weathering	8
b. One-Year UV Accelerated Weathering	8
c. Three-Year UV Accelerated Weathering	8
2. RAIN EROSION TEST RESULTS - SEM OBSERVATIONS	12
a. Vendor P - No Accelerated UV Weathering	12
b. Vendor P - One-Year Accelerated UV Weathering	12
c. Vendor P - Three-Year Accelerated UV Weathering	12

TABLE OF CONTENTS (Concluded)

Section		Page
III	TEST RESULTS (Concluded)	
	d. Vendor A - No Accelerated UV Weathering	13
	e. Vendor A - One-Year Accelerated UV Weathering	13
	f. Vendor A - Three-Year Accelerated UV Weathering	13
	g. Vendor B - No Accelerated UV Weathering	14
	h. Vendor B - One-Year Accelerated UV Weathering	14
	i. Vendor B - Three-Year Accelerated UV Weathering	14
	3. WEIGHT LOSS MEASUREMENTS	15
	4. HAZEMETER MEASUREMENTS	15
IV	DISCUSSION	16
	1. INTRODUCTION	16
	2. RAIN EROSION BEHAVIOR	16
	a. Rain Erosion Kinetics	16
	b. Effects of Accelerated UV Weathering	17
	c. Effects of Desert Sunshine Exposure	19
	3. RAIN EROSION PROCESSES	19
	a. Rain Erosion Initiation Process - Surface Coating	19
	b. Rain Erosion Initiation Process - Polycarbonate Substrate	20
	c. Rain Erosion Propagation Process - Surface Coating	20
	d. Rain Erosion Propagation Process - Polycarbonate Substrate	21
V	CONCLUSIONS AND RECOMMENDATIONS	22
	REFERENCES	25
	APPENDIX A: Percent Coating Removal and Weight Loss Data	26
	APPENDIX B: Scanning Electron Microscope Micrographs	37

LIST OF ILLUSTRATIONS

Figure		Page
1	Coated Monolithic Polycarbonate Test Specimen	3
2	Mach 1.2 Rain Erosion Test Apparatus	6
3	Percent Coating Removal vs. Time in Rain	9
4	Percent Coating Removal vs. Time in Rain	10
5	Percent Coating Removal vs. Time in Rain	11
B-1	Vendor P Coated Polycarbonate (No UV Exposure)	38
B-2	Vendor P Coated Polycarbonate (1 Yr UV Exposure)	39
B-3	Vendor P Coated Polycarbonate (3 Yr UV Exposure)	40
B-4	Vendor A Coated Polycarbonate (No UV Exposure)	41
B-5	Vendor A Coated Polycarbonate (1 Yr UV Exposure)	42
B-6	Vendor A Coated Polycarbonate (3 Yr UV Exposure)	43
B-7	Vendor B Coated Polycarbonate (No UV Exposure)	44
B-8	Vendor B Coated Polycarbonate (1 Yr UV Exposure)	45
B-9	Vendor B Coated Polycarbonate (3 Yr UV Exposure)	46
B-10	Vendor P Coated Polycarbonate (3 Yr EMMA)	47

LIST OF TABLES

Table		Page
A-1	Vendor P Coated Polycarbonate Rain Erosion Evaluation	27
A-2	Vendor A Coated Polycarbonate Rain Erosion Evaluation	28
A-3	Vendor B Coated Polycarbonate Rain Erosion Evaluation	29
A-4	Vendor P Coated Polycarbonate Rain Erosion Evaluation	30
A-5	Vendor A Coated Polycarbonate Rain Erosion Evaluation	31
A-6	Vendor B Coated Polycarbonate Rain Erosion Evaluation	32
A-7	Vendor P Coated Polycarbonate Rain Erosion Evaluation	33
A-8	Vendor A Coated Polycarbonate Rain Erosion Evaluation	34
A-9	Vendor B Coated Polycarbonate Rain Erosion Evaluation	35
A-10	Vendor P Coated Polycarbonate Rain Erosion Evaluation	36

SECTION I
INTRODUCTION

1. BACKGROUND

An increasing number of high performance aircraft are being fitted with transparencies utilizing polycarbonate (Mil-P-83310) material as the structural ply. This usage is dictated by the need to provide a transparency which can survive high speed impact energies. The impact resistance of polycarbonate material is influenced by such parameters as thickness, temperature, configuration, surface finish, aging and environmental exposure. Coated monolithic polycarbonate transparencies, as well as laminated acrylic/polycarbonate plies, are considered as current and potential future applications. In either case, outer and inner surface protection of the polycarbonate must be provided by protective coatings or acrylic plies.

Investigation of the rain erosion behavior of transparent plastics, specifically polysulfone and uncoated polycarbonate, has been conducted by the Air Force Wright Aeronautical Laboratories (AFWAL) Materials Laboratory and reported.⁽¹⁾ Although numerous proprietary coatings for polycarbonate have been evaluated in the AFWAL Materials Laboratory rotating arm apparatus over the past seven years, this represents the first systematic study of the influence of environmental exposures on the erosive behavior of those transparent coatings.

2. OBJECTIVE

The objective of this program was to determine the relative rain erosion resistance and damage mechanisms involved with different types of coated monolithic polycarbonate transparency materials. The materials were to be evaluated before and after simulated environmental exposure.

SECTION II
EXPERIMENTAL PROCEDURE

1. MATERIALS

All materials for evaluation were supplied by the U.S. Air Force. The materials were furnished in flat sheet form and processed to be representative of material used in aircraft transparencies. The three vendors supplying coated monolithic polycarbonate material are identified as Vendor P, Vendor A, and Vendor B. The base material for each vendor consisted of nominal 0.75 inch thickness. Three different coatings were utilized: Vendor P material was supplied with the Texstar C-254-1C coating, Vendor A had its own specific coating, and, similarly, Vendor B had its own specific coating.

2. TEST SPECIMEN FABRICATION

All specimens were first cut from the parent material sheet by band sawing. Cutting temperature was controlled during milling through the use of cooling air. Polarized light inspection was used in conjunction with the milling operation to ensure that the level of residual machining stress was very low near the milled edges. Great care was taken to ensure that the coated surfaces to be tested were not damaged or adversely affected by fabrication. The test specimens used for rain erosion evaluations required a reduction in thickness and two beveled edges as shown in Figure 1. The coated surface to be exposed to rain erosion was always protected during milling. This was done by keeping the protective paper used by the vendor on the coated surface during milling or by seating the coated surface on a teflon spacer bar during milling. After milling the backface was polished to a level which would allow meaningful visual, haze, and transmittance inspection before and after rain erosion exposure. Further descriptions of test specimen fabrication and conditioning can be found in Reference 2.

30° IMPACT ANGLE

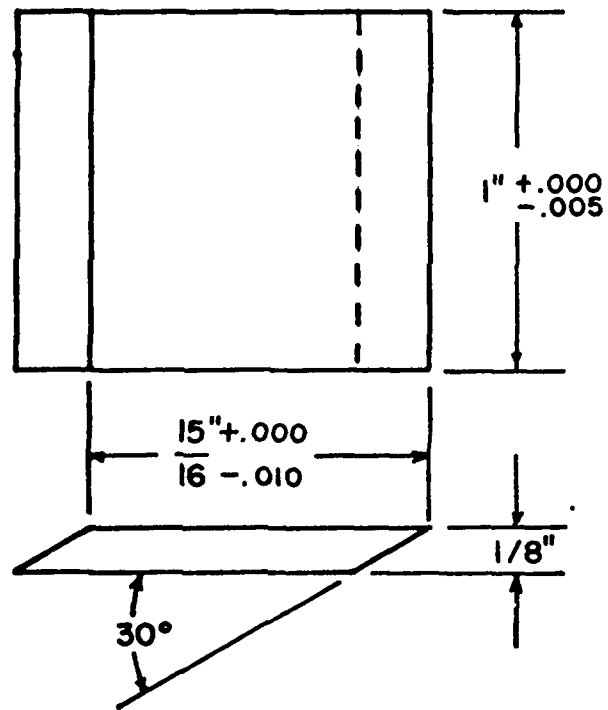

Figure 1. Coated Monolithic Polycarbonate Test Specimen.

3. ULTRAVIOLET RADIATION ENVIRONMENTAL CONDITIONING

a. Accelerated UV Laboratory Conditioning

The ultraviolet radiation environmental conditioning of the test specimens was implemented in two stages: the as-received baseline materials consisting of no UV exposure, and the baseline materials subjected to one and three years of accelerated laboratory UV exposure. All ultraviolet conditioning was performed using a "Sunlighter IV" accelerated sunlight tester, manufactured by the Test-Lab Apparatus Co., Amherst, New Hampshire. Basically, this apparatus consists of four sunlamp bulbs mounted over a rotating turntable. The tester acceleration ratio over natural sunlight is based on a cabinet temperature of 131°F-140°F. The energy level in the range where nearly all UV degradation occurs, supplied by the General Electric RS-4 sunlamp bulbs in the tester, varies from a wavelength of 290 millimicrons (nanometers) at an intensity of 1300 watts/sq. meter to 360 millimicrons at 30,000 watts/sq. meter; the wavelength of maximum sensitivity for polycarbonates being 295 millimicrons. Specimens were mounted on a screen to avoid contact with the nonreflective turntable.

One sunlamp bulb is mounted directly over the center portion of the turntable, and three additional bulbs are mounted over the outboard portion of the turntable. Consequently, two areas with different exposure accelerations are produced on the turntable, an inner circle of approximately six inches diameter, and the remaining outer ring of 17.5 inches diameter. For the inner circle, the acceleration ratio is approximately eight hours exposure equivalent to one year natural sunlight according to the manufacturers. The inner circle was used for all UV exposure of the rain erosion test specimens. For the purposes of this report, the data will indicate no accelerated UV weathering, one year UV accelerated weathering, and three year UV accelerated weathering, respectively.

b. Accelerated Outdoor Sunshine Conditioning

Accelerated outdoor weathering of simulated three-year exposure was accomplished by utilizing the Equatorial Mount with Mirrors for Acceleration (EMMA) machine at the Desert Sunshine Exposure Test (DSET) Laboratory near Phoenix, Arizona. It is estimated that 40 days of exposure on the EMMA machine is approximately equivalent to one year of exposure to 45-degree south natural weathering. The specimens receive about eight times as much radiation as those exposed on a follow-the-sun rack during equal periods of time. Each simulated year was based on an exposure rate of 164,250 langleys.

4. TEST SPECIMEN PRETEST EXAMINATION

The as-received, coated monolithic polycarbonate specimens were numbered and logged according to the standard procedure for the rain erosion test apparatus. All specimens were visually inspected for defects or damage. Specimens were cleaned with distilled water and lint-free cloth, dried overnight in a forced air oven at 125°F, and then weighed. Pretest hazemeter measurements and scanning electron microscopic analysis were performed on selected specimens from each vendor group and environmental condition.

5. MACH 1.2 RAIN EROSION TEST APPARATUS

This rotating arm apparatus consists of an eight-foot diameter double arm blade. It is designed to produce high tip velocities with negative lift and a low drag coefficient. Mated test specimens are mounted at the leading edge tip sections of the double rotating arm. The test specimens can be subjected to variable speeds of 0 to 900 mph. The double arm is mounted horizontally on a vertical drive shaft (see Figure 2). Simulated rainfall is produced by four curved manifold quadrants. Each manifold quadrant has 24 equally-spaced capillaries. Raindrop size and drop rate are controlled by the capillary orifice diameter and the head pressure of the water supply. The manifold quadrants

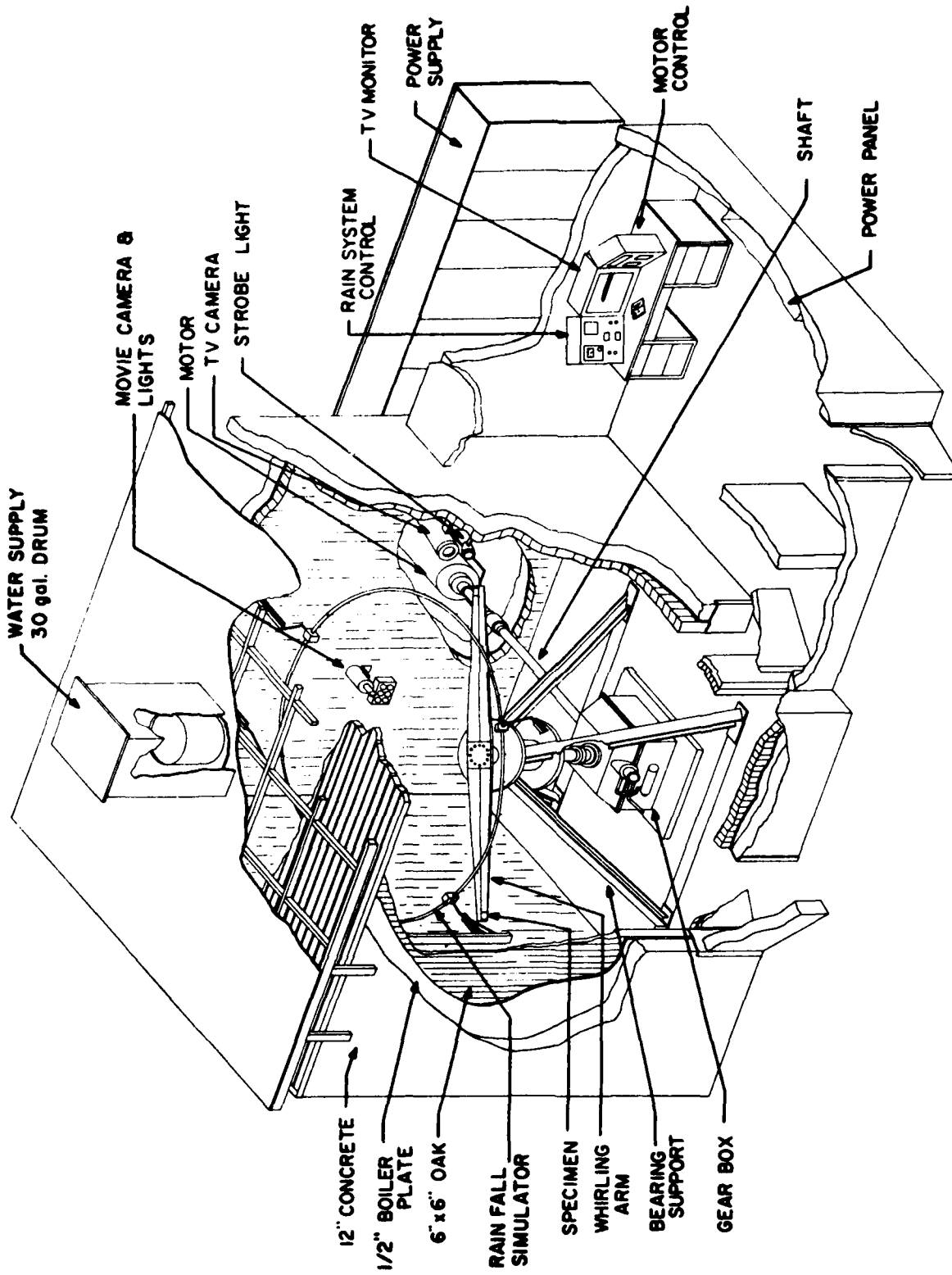

Figure 2. Mach 1.2 Rain Erosion Test Apparatus.

are mounted above the tips of the double rotating arm. Raindrops from the simulation apparatus impact the test specimens throughout their entire annular path. Rain droplets are 2.0 mm diameter and generated at the rate of one inch/hour of simulated rainfall. This apparatus is fully described in AFML-TR-70-240, dated October 1970. (3)

For the purposes of this study, matched pairs of specimens were inserted into the specimen holders at a 30° angle of incidence to the rain droplet impact. All rain erosion testing was conducted at 500 mph. Duration of the tests was established at 1, 2, 5, 10, and 15-minute intervals.

6. POST-TEST OBSERVATION AND EXAMINATION PROCEDURES

a. Visual Observation

All specimens were examined visually after rainfield exposure with a lighted magnifier, and the surface condition was recorded. Comments include: scratches, pitting, and percentage of coating removal.

b. Scanning Electron Microscopy Examination

The ETEC Autoscan High Resolution Scanning Electron Microscope is a second generation instrument. It incorporates such features as electron optics, specimen chamber, electron detection, and display systems. This instrument bridges the specimen gap between light and transmission electron microscopes. Specimens are vapor shadowed with a heavy metal or carbon to provide contrast. Resolution is of the order of 200Å and useful magnification up to 50,000X.

c. Hazemeter Measurements

Haze and transmission measurements were determined using the Standard Test Method for Haze and Luminous Transmittance of Transparent Plastics ASTM Method D 1003.

SECTION III
TEST RESULTS

1. RAIN EROSION TEST RESULTS - VISUAL EXAMINATION

a. No Accelerated UV Weathering

Visual examination, under a lighted magnifier, of the coated monolithic polycarbonate specimens exhibited initiation of coating removal from the Vendor P specimens occurring during the interval between two and five minutes of rainfield exposure. Vendor A specimens exhibited initiation of coating removal in the interval between five and ten minutes of rainfield exposure. Vendor B specimens exhibited surface pitting but no coating removal after 15 minutes of rainfield exposure. The worst case data is shown in Figure 3. The rain erosion data for specific specimens is shown in Appendix A, Tables A-1 through A-3.

b. One-Year UV Accelerated Weathering

The Vendor P specimens exhibited initiation of coating removal during the zero to one-minute interval of rainfield exposure. Vendor A specimens exhibited increased coating removal in the five to ten-minute interval of rainfield exposure. Vendor B specimens exhibited severe pitting of the coating surface at the 15-minute interval but no observable coating removal. The worst case data is shown in Figure 4. The rain erosion data for specific specimens is shown in Appendix A, Tables A-4 through A-6.

c. Three-Year UV Accelerated Weathering

The Vendor P specimens exhibited initiation of increased coating removal in the zero to one-minute interval of rainfield exposure. Vendor A specimens continued to exhibit initiation and percent of coating removal at the five to ten-minute interval of rainfield exposure. Vendor B exhibited severe pitting of the coating surface at the 15-minute interval but no observable coating removed. The worst case data is shown in Figure 5. The rain erosion data for specific specimens is shown in Appendix A, Tables A-7 through A-9.

SPEED: 500 MPH
RAINFALL: 1 IN/HR
NO ACCELERATED UV WEATHERING

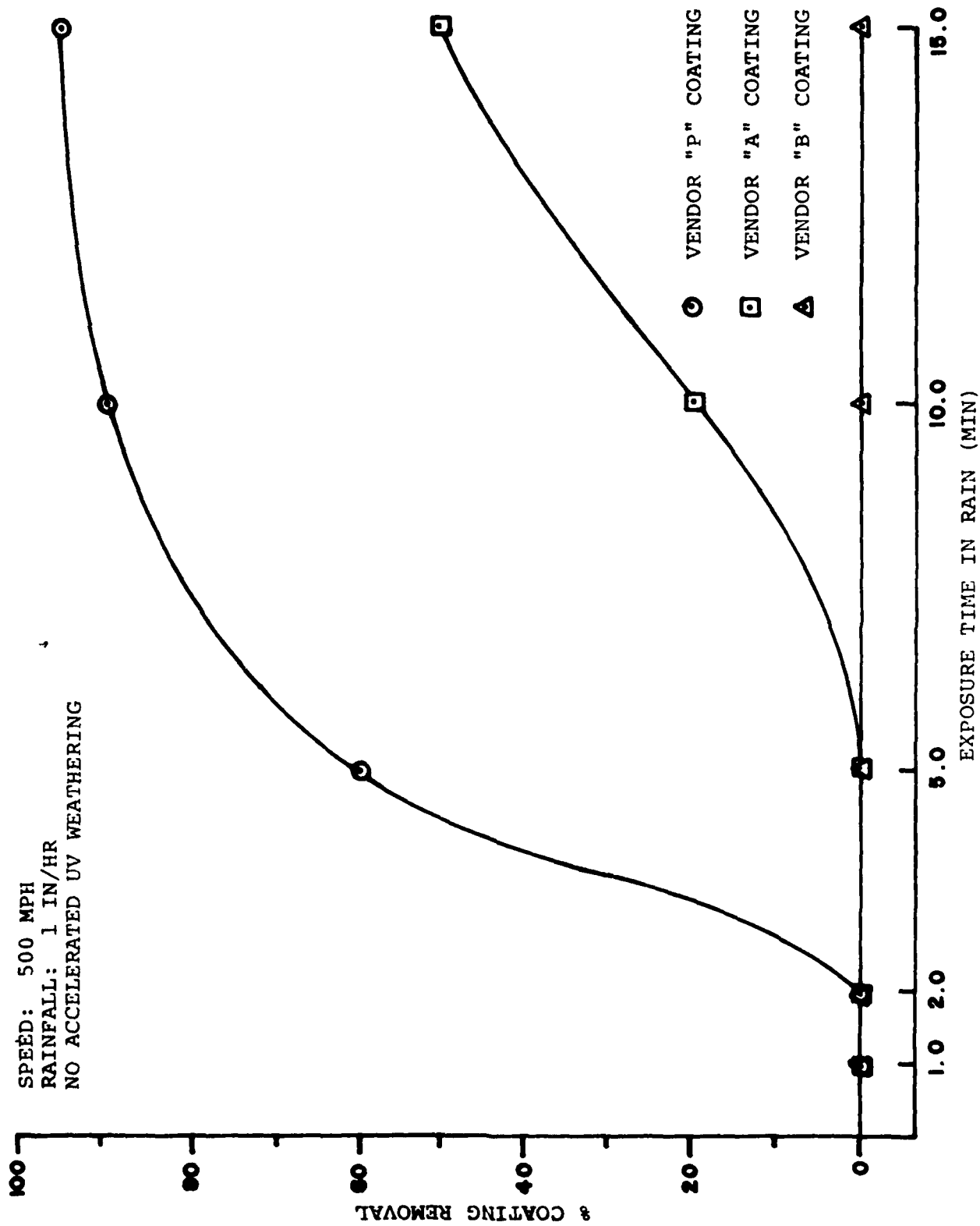

Figure 3. Percent Coating Removal vs. Time in Rain.

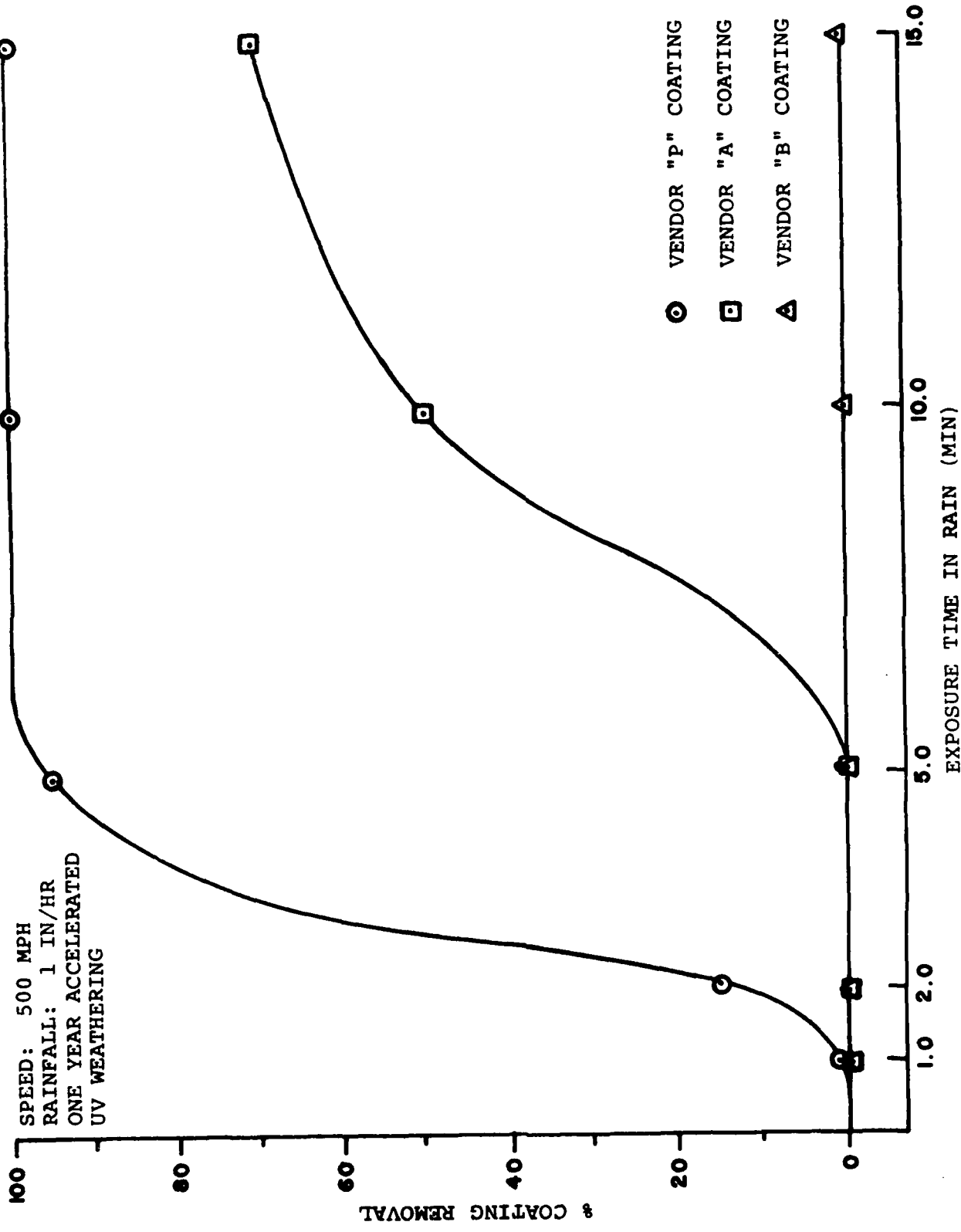

Figure 4. Percent Coating Removal vs. Time in Rain.

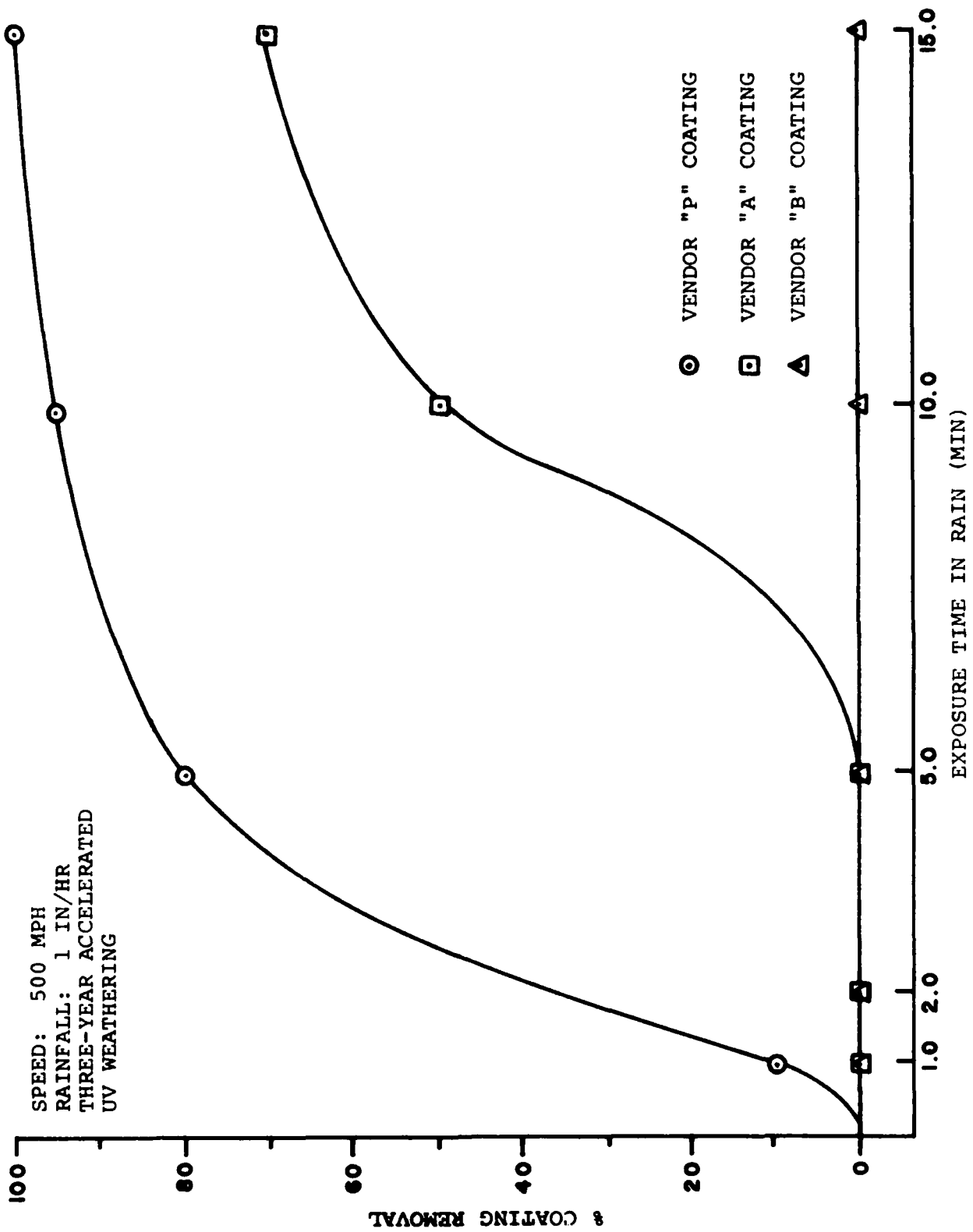

Figure 5. Percent Coating Removal vs. Time in Rain.

2. RAIN EROSION TEST RESULTS - SEM OBSERVATIONS

Selected test specimens which were exposed for varying time intervals to a one-inch-per-hour simulated rainfall at 500 miles per hour were examined by scanning electron microscopy (SEM) for characterization of the mode of erosion damage and erosive processes. The results obtained for coated monolithic polycarbonate materials supplied by the U.S. Air Force, designated as Vendor P, Vendor A, and Vendor B, are shown in Appendix B and are described herein.

a. Vendor P - No Accelerated UV Weathering

Exposure of the Vendor P non-UV exposed specimen to the previously described rain erosion test conditions resulted in coating surface damage as shown in Figure B-1. Short term exposure to rainfield conditions led to formation of localized defects in the coating surfaces up to 10 microns in diameter as shown in Figure B-1A. Further exposure to the rainfield led to the development of pits up to 30 microns in diameter at these localized damage sites and subsequently to localized coating removal (Figure B-1B). Continued exposures of five and 15 minutes to rainfield conditions resulted in substantial coating removal without introducing damage in the monolithic polycarbonate substrates as shown in Figures B-1C and B-1D, respectively.

b. Vendor P - One-Year Accelerated UV Weathering

Two minutes exposure to rainfield conditions of the Vendor P one-year UV exposed specimens resulted in typical coating damage and removal, and these specimens are shown in Figures B-2A and B-2B. Further exposure to rainfield conditions resulted in progressive coating removal as well as introducing localized cratering of about 10 microns in diameter in the monolithic polycarbonate substrate as can be seen in Figures B-2C and B-2D.

c. Vendor P - Three-Year Accelerated UV Weathering

Typical surface damage of the Vendor P three-year UV exposed test specimens exposed to rainfield conditions is shown in Figure B-3. In Figure B-3A coating damage and removal from

the substrate after one minute of rainfield exposure is clearly shown. Coating damage and removal associated with damage to the polycarbonate substrate is revealed in the specimens exposed for two and 10 minutes of rainfield exposure as is shown in Figures B-3B and B-3C, respectively.

d. Vendor A - No Accelerated UV Weathering

The typical mode of surface coating damage engendered by rain erosion processes for Vendor A no UV treatment test specimens with rainfield exposures up to two minutes is shown in Figure B-4. Initial coating damage was characterized by isolated and localized events of eroded or removed coating material in the range of 30 to 50 microns in diameter. This is clearly shown in Figures B-4A and B-4B. Further exposure of test specimens to rainfield exposures of 10 minutes resulted in progressive coating removal associated with crack formation but without introducing cratering damage into the polycarbonate substrate, as is shown in Figures B-4C and B-4D.

e. Vendor A - One-Year Accelerated UV Weathering

Figure B-5 shows the mode of surface damage obtained in Vendor A one-year UV treated test specimens after rainfield exposures up to 15 minutes. The damage is characterized by coating removal associated with coating separation and crack formation as shown in Figures B-5A and B-5B. Furthermore, noticeable streamlike lines were detected in the coating as indicated in Figure B-5B. This may be indicative of some phase (compositional or structural) changes within the substrate or the coating itself.

f. Vendor A - Three-Year Accelerated UV Weathering

The Vendor A test specimens subjected to the equivalent of three years UV exposure and subsequently to rainfield exposure underwent surface damage as shown in Figure B-6. Coating material was removed as well as formation of elongated channels of 1 to 10 microns in width together with craters or pits up to 20 microns in diameter were detected in the polycarbonate substrate surface

as shown in Figures B-6A and B-6B. These specimens were exposed to the rainfield for 10 minutes and 15 minutes for test specimens in Figures B-6C and B-6D. The elongated channel-like lines appeared in groups aligned in various directions to each other. However, within the individual group, these channels tended to be parallel with one another. The formation of such surface morphology suggests that the material may have undergone phase compositional or structural changes as a result of UV exposure and subsequent rainfield exposure.

g. Vendor B - No Accelerated UV Weathering

Surface morphology of the Vendor B no UV treatment test specimens is shown in Figure B-7. Rainfield exposure of the test specimens for periods ranging from 2 to 15 minutes resulted in localized erosion sites up to 20 microns in diameter as shown in Figures B-7A, B-7B, and B-7C, respectively. These erosion sites were characterized by the formation of craters or pits engendering one another (Figure B-7A) as well as micro cracks in the coating (Figures B-7A and B-7C). Furthermore, in only a few of the erosion sites was the coating completely removed from the substrate. This is depicted in Figure B-7C; however, no substantial coating removal was detected.

h. Vendor B - One-Year Accelerated UV Weathering

The Vendor B test specimens exposed to the equivalent of one year UV exposure and subsequently to rainfield exposure are shown in Figure B-8. Localized sites characterized by coating removal were observed after 1 and 10 minutes of rainfield exposure as shown in Figures B-8A and B-8B, respectively. These local sites were approximately 100 microns in diameter. No substantial amount of coating removal was detected in these specimens.

i. Vendor B - Three-Year Accelerated UV Weathering

The Vendor B three-year UV treated specimens and subsequent rainfield exposure are shown in Figure B-9. These

observations were characterized by the presence of localized sites of eroded coating material and coating removal ranging up to 200 microns in diameter as shown in Figures B-9A, B-9B, and B-9D. These represent rainfield exposure of 1 and 10 minutes, respectively.

3. WEIGHT LOSS MEASUREMENTS

For the purposes of this evaluation study, weight loss measurements were ineffective as an indicator and were further complicated by calcium carbonate deposits on the specimen. Deposits were the result of evaporation of hard water deposits from the rain simulation system.

4. HAZEMETER MEASUREMENTS

Haze and transmittance measurements were insensitive indicators to evaluate rain erosion resistance of the coated polycarbonate. Due to the calcium carbonate deposits and the type of failures involved, these measurements were terminated early in the program.

SECTION IV DISCUSSION

1. INTRODUCTION

The behavior of the three types of coated monolithic polycarbonate materials (Vendor P, Vendor A, and Vendor B) under rainfield exposure conditions before and after exposure to accelerated UV weathering were investigated and evaluated. The effects of accelerated UV weathering and exposure time under rainfield conditions were characterized by specific damage categories of coating erosion, coating removal, and substrate erosion. These erosion processes as well as their mechanism will be discussed herein.

2. RAIN EROSION BEHAVIOR

a. Rain Erosion Kinetics

In this study the rain erosion kinetics were characterized by the amount of coating removal from the coated monolithic polycarbonate material with exposure time under rainfield conditions. The kinetic behavior of coatings removal was similar for Vendor P and Vendor A materials before and after accelerated UV weathering as shown in Figures 3, 4, and 5. An S-curve type behavior was exhibited by these materials with incubation periods ranging from two to five minutes for Vendor P and Vendor A materials, respectively. Longer incubation time, probably, can be attributed to better adhesion of the Vendor A coating to the polycarbonate substrate (Figure B-4) as compared to the Vendor P coating (Figures B-1C and B-2B). Increased rainfield exposure time, beyond the so-defined incubation period, resulted in substantial increases in coating removal reaching a saturation level of nearly 100% coating removal in the Vendor P coating (Figures 3, 4, and 5). Vendor A coating exhibited a lower rate of coating removal after the incubation period and began to level off at values of 60-70% coating removal after 15 minutes of rainfield

exposure. The increased rate of gross coating removal in the S-shape mode is probably associated with the critical impact energy on the coatings surface needed initially to reduce the adhesive forces at the coating substrate interface and the subsequent delamination and peeling of the coatings.

Vendor A coating can be construed to be more ductile than the Vendor P coating. This can be deduced by comparing Figures B-5A and B-5B (where coating foldback was possible due to high coating ductility) with Figure B-2A (where coating brittleness is demonstrated by the formation of sharp boundaries and cracks in the zones of removed coating). Vendor A coating, being more ductile than the Vendor P coating, could absorb more of the rain droplet impact energy and still remain in contact with the polycarbonate substrate. This resulted in a longer incubation period as well as a decreased coating removal rate as compared to the Vendor P coating.

Coating removal in the Vendor B material was nearly zero percent, being independent of rainfield exposure time as well as UV radiation exposure effects (Figures 3, 4, and 5). The fact of no substantial coating removal on the Vendor B material could be associated with the existence of high adhesion forces between the coating and substrate interface. This may be deduced from Figure B-8B as well as from Figures B-7A and B-9C, where the coating itself was eroded prior to being delaminated from the substrate surface.

b. Effects of Accelerated UV Weathering

The effects of UV exposure on the subsequent rain erosion behavior of the Vendor P, A, and B materials were evaluated through the kinetic behavior of coating removal and surface characterization obtained by SEM observations. Exposure of Vendor P material to accelerated UV weathering resulted in a reduced incubation of 0.5 minutes. The incubation time of the Vendor A material was not affected by accelerated UV weathering exposure; however, coating removal rate did increase with UV exposure time as shown by comparing Figures 3 and 4. Furthermore,

exposure to accelerated UV weathering caused an increased coating removal rate as well as introducing damage into the polycarbonate substrates of Vendor P and Vendor A. These observations are depicted in Figures B-2C, B-2D, B-3B, B-3C, and in Figures B-6A, B-6B, and B-6C. These findings suggest the probability that accelerated UV weathering affected the polycarbonate substrates. Polycarbonate is known to be sensitive to UV radiation, especially in the presence of moisture as reported in References 2, 4, and 5. Consequently, the resultant reduction in adhesion of the coatings to the polycarbonate substrates at their interface led to the decrease in incubation time as well as an increase in the rate of coating removal in the Vendor P and Vendor A materials.

Since the polycarbonate substrates were apparently affected by accelerated UV weathering, it is suggested that the Vendor P and Vendor A coatings were transparent in the UV wavelength region; whereas in the Vendor B material, essentially no coating removal was visually observed as well as no apparent damage to the polycarbonate substrate as shown in Figures B-8 and B-9. These observations suggest that the Vendor P and Vendor A coatings did not contain the necessary type and amount of UV absorbers. The Vendor B coating may have contained sufficient amounts of UV absorbers which apparently prevented damage to the polycarbonate substrate and consequently the delamination and coating removal. Accelerated UV weathering did not substantially affect the coating properties as far as their rain erosion behavior is concerned. In all three cases, Vendor P, A, and B coatings were subject to rain erosion damage prior to accelerated UV weathering. This is demonstrated in Figures B-1C, B-4B, and B-7A, respectively. Similar rain erosion damage after exposure to accelerated UV weathering is demonstrated in Figures B-2B, B-6D, and B-9C, respectively. These observations support the hypothesis that accelerated UV weathering did not directly affect the coatings behavior under rainfield exposure conditions, but rather had an indirect effect through the reduction of adhesion to the polycarbonate substrate as discussed above.

c. Effects of Desert Sunshine Exposure

Exposure of the Vendor P material to Desert Sunshine EMMA test described in Section II, 3.b. for the equivalent of three years exposure and thereafter to rainfield exposure conditions resulted in coating removal as shown in Figures B-10A and B-10B. Damage was also introduced into the polycarbonate substrate as shown in B-10C and B-10D. The mode of coating removal was very similar to the Vendor P specimens exposed to accelerated UV weathering in the laboratory as described in Section II, 3.a. and depicted in Figures B-2A and B-3A. Furthermore, the mode of damage introduced in the polycarbonate substrate was associated with the formation of craters together with microcracks, as was the case for the laboratory UV irradiated Vendor P materials (Figures B-2C, B-2D, and B-3C). Based on these findings, it is possible to deduce that there is a good correlation between the rain erosion behavior of the Vendor P laboratory UV irradiated specimens and the Vendor P desert sunshine exposures.

3. RAIN EROSION PROCESSES

The rain erosion processes observed in the Vendor P, A, and B, UV irradiated and non-UV irradiated specimens can be characterized through two basic stages: (a) initiation process and (b) propagation process. These processes are discussed herein.

a. Rain Erosion Initiation Process - Surface Coating

The initiation process was associated with the incubation time as shown by the kinetic curves in Figures 3, 4, and 5. The erosion process at the initiation stage was characterized by local erosion processes which resulted in the formation of isolated craters or pits in the range of 10 to 30 μm in size (Figures B-1A and B-1B for the Vendor P coating, Figures B-4A and B-4B for the Vendor A coating, and Figures B-7A and B-9 for the Vendor B coating). These localized events consisted of material removal from the coating (Figure B-4B) as well as localized coating separation from the polycarbonate substrate (Figure B-9B).

The local isolated events merged with each other and will be discussed later.

b. Rain Erosion Initiation Process - Polycarbonate Substrate

Further exposure of the test specimens, beyond the incubation period, resulted in rain erosion damage in the polycarbonate substrate material. This was observed in the UV irradiated test specimens of the Vendor P and A substrates but not in the Vendor B substrates. The initiation stage of rain erosion damage was characterized by the formation of localized craters or pits, up to 10 microns in diameter, with associated microcracks as shown in Figures B-2C, B-2D, and B-3C. These events resulted from direct localized removal of polycarbonate material characterized as direct erosion damage. Further investigation should be carried out to identify the initial formation and propagation of microcracks.

c. Rain Erosion Propagation Process - Surface Coating

The propagation stage of the rain erosion process, affecting the surface coatings, occurred through the joining of the local damage events as depicted in Figure B-1B and B-2A. Continuation of the damage "growth" process of the local events resulted in the coating removal of large areas a few hundred microns in size, and subsequently from the entire area of the test specimens exposed to rainfield conditions. The results of this propagation process are clearly shown in Figure B-3A as well as in Figures B-10A and B-10B. Coating removal through the propagation stage correlated with the high rate of coating removal as shown in the S-type kinetic curves. Whenever the propagation stage of uniting local erosion events stopped, no general erosion damage, i.e. coating removal, occurred and the coating surface remained fundamentally undamaged as observed in the Vendor B materials (Figures B-8A, B-9A, and B-9D). The observation that no advanced propagation stage occurred in the Vendor B material was also reflected in the kinetic curves, where the amount of coating material removal was essentially insignificant.

d. Rain Erosion Propagation Process - Polycarbonate Substrate

The erosion propagation mode in the polycarbonate substrate could be characterized in several forms as indicated in Figures B-6A and B-6B. One form suggests the combination of initially formed craters or pits, after growth to 30 microns in size, to form an elongated channel along the diagonal of Figure B-6B. Another form suggests the joining of minute isolated events (one micron in size) to form a continuous stream of parallel channels as depicted in Figure B-6B. Nevertheless, further investigation should be considered in order to provide more data to evaluate and support the actual mode of rain erosion damage in the polycarbonate substrate.

SECTION V
CONCLUSIONS AND RECOMMENDATIONS

Visual examination of the Vendor P, A, and B specimens after rainfield exposure indicated the following.

The Vendor P coating with no accelerated UV weathering exhibited initiation of coating removal between two and five minutes of rainfield exposure. One-year and three-year accelerated UV weathering of Vendor P specimens caused a decrease in the time of initiation of coating removal and an increase in the amount of coating removal as a function of rainfield exposure time.

The Vendor A coating with no accelerated UV weathering exhibited initiation of coating removal between five and ten minutes of rainfield exposure. One-year and three-year accelerated UV weathering of Vendor A specimens resulted in increased coating removal as a function of rainfield exposure.

The Vendor B coating with no accelerated UV weathering exhibited surface pitting but no observable coating removal after 15 minutes of rainfield exposure. One-year and three-year accelerated UV weathering of Vendor B specimens continued to exhibit no observable coating removal as a function of rainfield exposure.

SEM observations of the Vendor P, A, and B specimens after rainfield exposure indicated the following.

Short-term rainfield exposure of Vendor P specimens with no accelerated UV exposure induced localized surface defects in the coating. Increased rainfield exposure time led to pit formation and localized coating removal. Further exposures resulted in substantial coating removal without introducing damage in the polycarbonate substrate. Short-term rainfield exposure of the one-year and three-year accelerated UV weathering specimens exhibited increased coating damage and coating removal, as well as localized cratering in the polycarbonate substrate at the 10 and 15-minute intervals of rainfield exposure for the one-year

accelerated UV weathered specimens and two to 10-minute intervals for the three-year UV weathered specimens.

Short-term rainfield exposure of Vendor A specimens with no accelerated UV weathering exhibited isolated and localized areas of coating removal. Further rainfield exposure resulted in progressive coating removal and crack formation without cratering damage to the polycarbonate substrate. One-year accelerated UV weathering of Vendor A specimens produced increased coating removal and crack formation as a function of rainfield exposure time, as well as coating separation and noticeable streamlike lines. The streamlike lines may be indicative of some phase change within the coating or substrate. Vendor A specimens subjected to three-year accelerated UV weathering exhibited the same rate of surface damage and coating removal as the one-year accelerated UV weathering Vendor A specimens. In addition, craters or pits, as well as formation of elongated channels, were detected in the polycarbonate substrate.

Two to 10 minutes of rainfield exposure of the Vendor B specimens with no accelerated UV weathering resulted in localized erosion sites characterized by the formation of craters and associated microcracks. No substantial coating removal was detected. One-year and three-year accelerated UV weathering of Vendor B specimens exhibited localized erosion sites of eroded coating material and coating removal. No substantial coating removal was detected.

The kinetic behavior of coating removal was similar for Vendor P and Vendor A before and after accelerated UV weathering. A longer erosion incubation period for Vendor A is attributed to better adhesion of the coating to the polycarbonate substrate. The fact of no substantial coating removal on the Vendor B material could be associated with the existence of high adhesion forces between the coating and the substrate interface.

Exposure of the Vendor P specimens to accelerated UV weathering reduced the erosion incubation period. The incubation period

of erosion of the Vendor A specimens was not affected by accelerated UV weathering exposure. However, the rate of coating removal did increase with UV exposure. Also, accelerated UV weathering exposure introduced cratering and pitting into the polycarbonate substrates of Vendor P and Vendor A. The Vendor B specimens with accelerated UV weathering exposure resulted in no substantial coating removal, as well as no apparent damage to the polycarbonate substrate.

Vendor P and A may not have contained the necessary type and amount of UV absorber to prevent substrate damage and coating removal. Vendor B may have contained sufficient amounts of UV absorbers or the coating itself may have been sufficiently resistant to incident UV light to apparently prevent substrate damage and delamination and coating removal.

Accelerated UV weathering exposure did not directly affect the coatings behavior under rainfield exposure conditions but did have an indirect effect on the adhesion of the coatings to the polycarbonate substrates.

There is good data correlation between the Vendor P coatings exposed to accelerated UV weathering exposure in the laboratory and those exposed to the desert sunshine EMMA test. The mode of coating removal and mode of damage to the polycarbonate substrate was similar.

Visual observations of coating damage and coating removal are an effective means of making relative comparisons between materials. However, visual observations are limited in their ability to determine erosion mechanisms in coated transparent materials.

Scanning electron microscopy techniques are most effective in assessing the role of mechanistic processes in rain erosion phenomena. These techniques can detect incubation and initiation stages, erosion characteristics, i.e. pitting, cratering and microcracking, and adhesion characteristics of coated materials.

Vendor B materials were the most resistant to erosion processes regardless of their pretest environmental exposures and duration of rainfield exposure conditions.

REFERENCES

1. G.F. Schmitt, Jr. and R.E. Hall, "Effects of a Rain Erosive Environment on the Transmission of Optically Transparent Plastic Materials," AFML-TR-73-136, Air Force Materials Laboratory, Wright Patterson AFB, Ohio, August 1973.
2. K.I. Clayton, J.F. Milholland, G.J. Stenger, Experimental Evaluation of F-16 Polycarbonate Canopy Material, AFWAL-TR-81-4020, Air Force Wright Aeronautical Laboratories, Wright Patterson AFB, Ohio, April 1981.
3. C.J. Hurley and G.F. Schmitt, Jr. Development and Calibration of a Mach 1.2 Rain Erosion Test Apparatus, AFML-TR-70-240, Air Force Materials Laboratory, Wright Patterson AFB, Ohio, October 1970.
4. Davis, A., Golden, J.H., Macromol. Sci. -C, 3, 49 (1969).
5. Yamasaki, R.S., Blaga, A., Mat of Const., 10, 197 (1977).

APPENDIX A
PERCENT COATING REMOVAL AND WEIGHT LOSS DATA

TABLE A-1
 VENDOR P COATED POLYCARBONATE
 RAIN EROSION EVALUATION

SPEED: 500 MPH RAINFALL: 1 IN/HR

<u>Specimen No.</u>	<u>Exp Time</u>	<u>Weight Loss (gm)</u>	<u>Visual Examination</u>
11289	1.0	+0.0005	Surface Scratch
11290	1.0	+0.0016	Surface Scratch
11295	2.0	.0001	Surface Pitting
11296	2.0	.0012	Surface Pitting
11291	5.0	.0051	60% Coating Removal
11292	5.0	.0053	60% Coating Removal
11293	10.0	.0059	90% Coating Removal
11294	10.0	.0073	90% Coating Removal
11299	15.0	.0071	95% Coating Removal & Substrate Pitting
11300	15.0	.0176	95% Coating Removal & Substrate Pitting
11297	30.0	.0008	100% Coating Removal
11298	30.0	.0001	100% Coating Removal

+ indicates a weight gain after evaluation

TABLE A-2
 VENDOR A COATED POLYCARBONATE
 RAIN EROSION EVALUATION

SPEED: 500 MPH RAINFALL: 1 IN/HR

<u>Specimen No.</u>	<u>Exp Time</u>	<u>Weight Loss (gm)</u>	<u>Visual Examination</u>
11305	1.0	.0000	No Visible Damage
11306	1.0	.0012	Surface Scratch
11311	2.0	+.0001	Slight Damage
11312	2.0	.000	No Visible Damage
11307	5.0	.0008	Surface Scratches
11308	5.0	.0006	Surface Scratches
11309	10.0	.0018	Slight Damage
11310	10.0	.0016	20% Coating Removal
11313	15.0	.0058	50% Coating Removal
11314	15.0	.0011	Coating Edge Removal

TABLE A-3
 VENDOR B COATED POLYCARBONATE
 RAIN EROSION EVALUATION

SPEED: 500 MPH RAINFALL: 1 IN/HR

<u>Specimen No.</u>	<u>Exp Time</u>	<u>Weight Loss (gm)</u>	<u>Visual Examination</u>
11325	1.0	.0005	No Visible Damage
11326	1.0	.0007	Surface Scratch
11331	2.0	.0005	Surface Scratch
11332	2.0	.0002	No Damage
11327	5.0	.0010	Surface Scratch
11328	5.0	.0004	Small Pits
11329	10.0	.0009	No Damage
11330	10.0	.0008	Scratches & Pits
11333	15.0	.0003	Scratches & Pits
11334	15.0	.0016	Scratches & Pits

TABLE A-4
VENDOR P COATED POLYCARBONATE
RAIN EROSION EVALUATION

SPEED: 500 MPH RAINFALL: 1 IN/HR
1 YEAR SIMULATED UV EXPOSURE

<u>Specimen No.</u>	<u>Exp Time</u>	<u>Weight Loss (gm)</u>	<u>Visual Examination</u>
11510	1.0	.0012	1% Coating Removal
11511	1.0	.0006	No Damage
11512	2.0	.0018	5% Coating Removal
11513	2.0	.0018	15% Coating Removal
11520	5.0	.0062	80% Coating Removal
11521	5.0	.0066	95% Coating Removal
11516	10.0	.0073	100% Coating Removal
11517	10.0	.0099	100% Coating Removal
11518	15.0	.0084	100% Coating Removal
11519	15.0	.0089	100% Coating Removal

TABLE A-5
 VENDOR A COATED POLYCARBONATE
 RAIN EROSION EVALUATION

SPEED: 500 MPH RAINFALL: 1 IN/HR
 1 YEAR SIMULATED UV EXPOSURE

<u>Specimen No.</u>	<u>Exp Time</u>	<u>Weight Loss (gm)</u>	<u>Visual Examination</u>
11384	1.0	.0003	Surface Scratches
11385	1.0	+.0009	Minor Pitting
11386	2.0	.0004	Scratches
11387	2.0	.0007	Scratches & Edge Removal
11388	5.0	.0018	Surface Scratches
11389	5.0	.0005	Surface Scratches & Edge Damage
11390	10.0	.0055	50% Coating Removal
11391	10.0	.0012	No Damage
11392	15.0	.0008	Coating Edge Removal
11393	15.0	.0066	70% Coating Removal

TABLE A-6
 VENDOR B COATED POLYCARBONATE
 RAIN EROSION EVALUATION

SPEED: 500 MPH RAINFALL: 1 IN/HR
 1 YEAR SIMULATED UV EXPOSURE

<u>Specimen No.</u>	<u>Exp Time</u>	<u>Weight Loss (gm)</u>	<u>Visual Examination</u>
11454	1.0	.0020	No Damage
11455	1.0	.0012	Slight Pitting
11456	2.0	.0017	No Damage
11457	2.0	.0015	No Damage
11458	5.0	.0009	Slight Pitting
11459	5.0	.0011	Slight Pitting
11460	10.0	.0005	Pitting
11461	10.0	.0019	Pitting
11465	15.0	.0028	Severe Pitting
11466	15.0	.0034	Severe Pitting
11467	15.0	.0020	Severe Pitting

TABLE A-7
 VENDOR P COATED POLYCARBONATE
 RAIN EROSION EVALUATION

SPEED: 500 MPH RAINFALL: 1 IN/HR
 3 YEAR SIMULATED UV EXPOSURE

<u>Specimen No.</u>	<u>Exp Time</u>	<u>Weight Loss (gm)</u>	<u>Visual Examination</u>
11550	1.0	.0001	No Damage
11551	1.0	.0004	10% Coating Removal
11552	2.0	.0013	Pitting
11553	2.0	.0003	Pitting
11506	2.0	.0007	5% Coating Removal
11507	2.0	.0018	2% Coating Removal
11498	2.0	+.0005	3% Coating Removal
11499	2.0	.0000	3% Coating Removal
11502	10.0	.0091	95% Coating Removal
11503	10.0	.0000	No Damage
11500	15.0	.0070	100% Coating Removal & Substrate Pitting
11501	15.0	.0064	100% Coating Removal & Substrate Pitting

TABLE A-8
 VENDOR A COATED POLYCARBONATE
 RAIN EROSION EVALUATION

SPEED: 500 MPH RAINFALL: 1 IN/HR
 3 YEAR SIMULATED UV EXPOSURE

<u>Specimen No.</u>	<u>Exp Time</u>	<u>Weight Loss (gm)</u>	<u>Visual Examination</u>
11472	1.0	.0004	Minor Pitting
11473	1.0	.0001	Minor Pitting
11556	2.0	.0001	Coating Edge Removal
11557	2.0	+.0005	Coating Edge Removal
11474	5.0	.0000	No Damage
11475	5.0	.0003	No Damage
11558	10.0	.0048	50% Coating Removal
11559	10.0	.0004	Coating Edge Removal
11560	15.0	+.0003	Coating Edge Removal
11561	15.0	.0071	70% Coating Removal

TABLE A-9
VENDOR B COATED POLYCARBONATE
RAIN EROSION EVALUATION

SPEED: 500 MPH RAINFALL: 1 IN/HR
3 YEAR SIMULATED UV EXPOSURE

<u>Specimen No.</u>	<u>Exp Time</u>	<u>Weight Loss (gm)</u>	<u>Visual Examination</u>
11484	1.0	.0002	Minor Pitting
11485	1.0	.0004	Minor Pitting
11490	2.0	.0008	Pitting
11491	2.0	.0007	Pitting
11486	5.0	.0011	Pitting
11488	5.0	.0006	Pitting
11492	10.0	.0055	Severe Pitting
11493	10.0	.0052	Severe Pitting
11494	15.0	.0042	Severe Pitting
11495	15.0	.0054	Severe Pitting

TABLE A-10
VENDOR P COATED POLYCARBONATE
RAIN EROSION EVALUATION

SPEED: 500 MPH RAINFALL: 1 IN/HR
3 YEAR EMMA EXPOSURE

<u>Specimen No.</u>	<u>Exp Time</u>	<u>Weight Loss (gm)</u>	<u>Visual Examination</u>
11361	1.0	.0014	Surface Pitting

APPENDIX B
SCANNING ELECTRON MICROSCOPE MICROGRAPHS

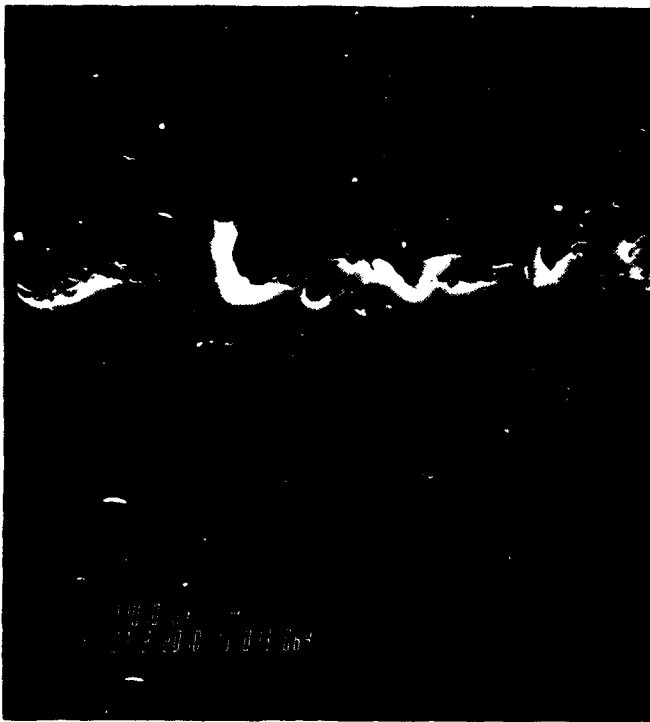

A 1.0 min Rain Exposure



B 2.0 min Rain Exposure



C 5.0 min Rain Exposure



D 15.0 min Rain Exposure

Figure B-1. Vendor P Coated Polycarbonate (No UV Exposure).



A 2.0 min Rain Exposure

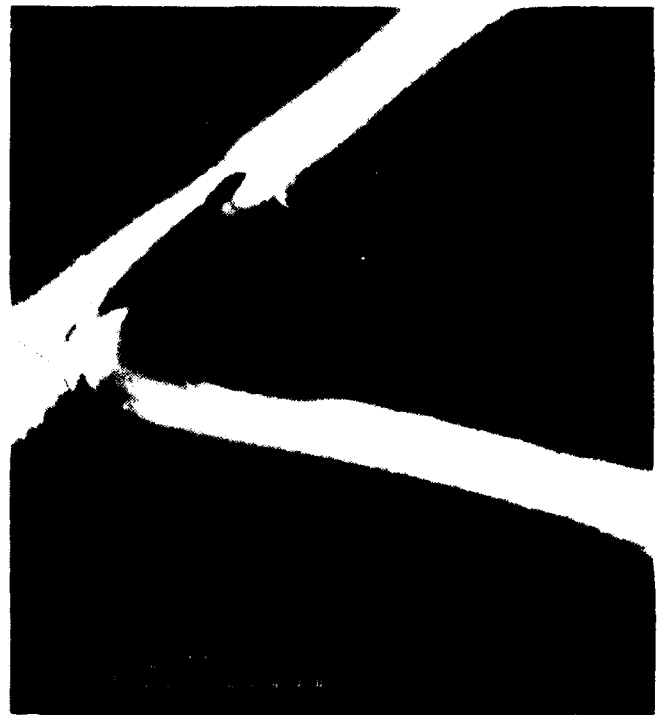

B 2.0 min Rain Exposure



C 10.0 min Rain Exposure



D 15.0 min Rain Exposure

Figure B-2. Vendor P Coated Polycarbonate (1 Yr UV Exposure).



A 1.0 min Rain Exposure



B 2.0 min Rain Exposure

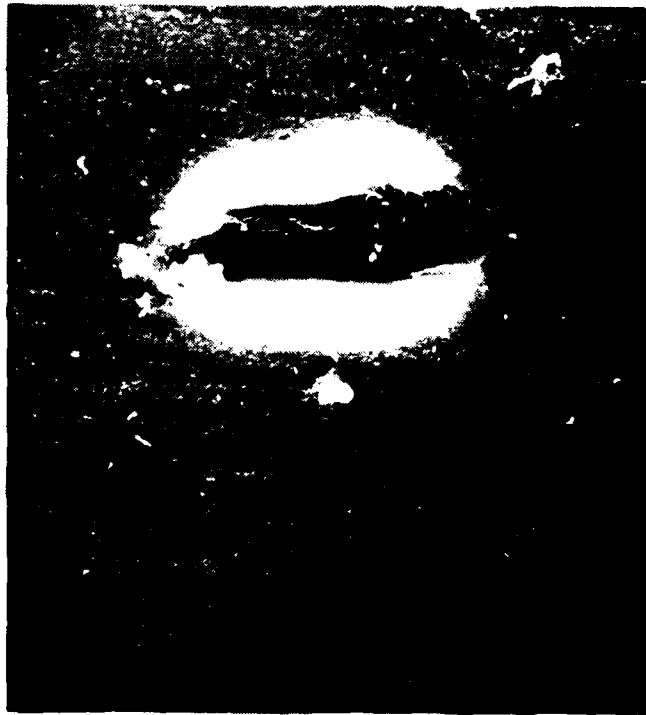

C 10.0 min Rain Exposure

Figure B-3. Vendor P Coated Polycarbonate (3 Yr UV Exposure).



A 2.0 min Rain Exposure



B 2.0 min Rain Exposure



C 10.0 min Rain Exposure



D 10.0 min Rain Exposure

Figure B-4. Vendor A Coated Polycarbonate (No UV Exposure).



A 5.0 min Rain Exposure



B 5.0 min Rain Exposure



C 15.0 min Rain Exposure

Figure B-5. Vendor A Coated Polycarbonate (1 Yr UV Exposure).



A 10.0 min Rain Exposure



B 10.0 min Rain Exposure

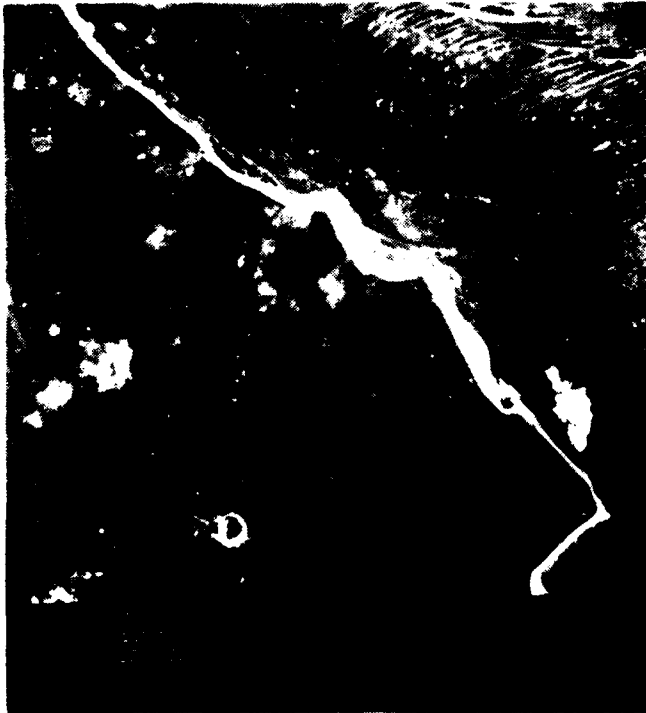

C 15.0 min Rain Exposure



D 15.0 min Rain Exposure

Figure B-6. Vendor A Coated Polycarbonate (3 Yr UV Exposure).



A 2.0 min Rain Exposure



B 15.0 min Rain Exposure



C 15.0 min Rain Exposure

Figure B-7. Vendor B Coated Polycarbonate (No UV Exposure).

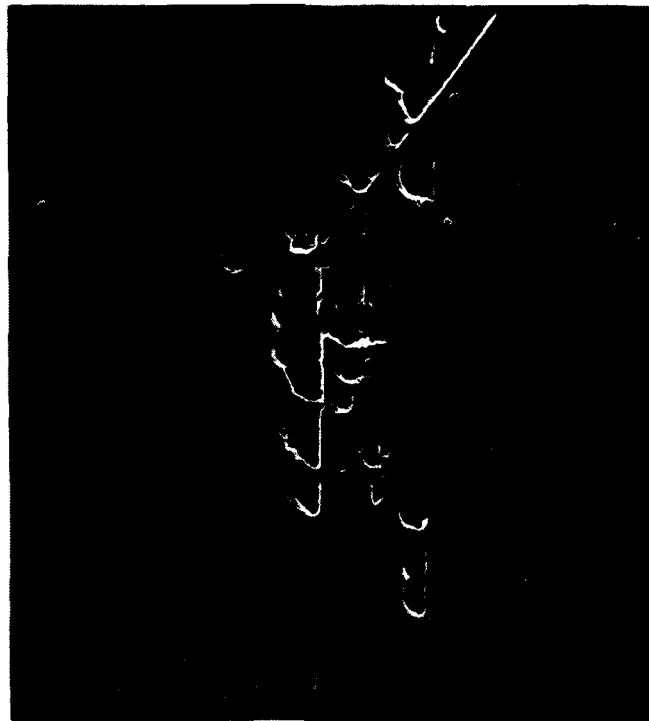

A 1.0 min Rain Exposure

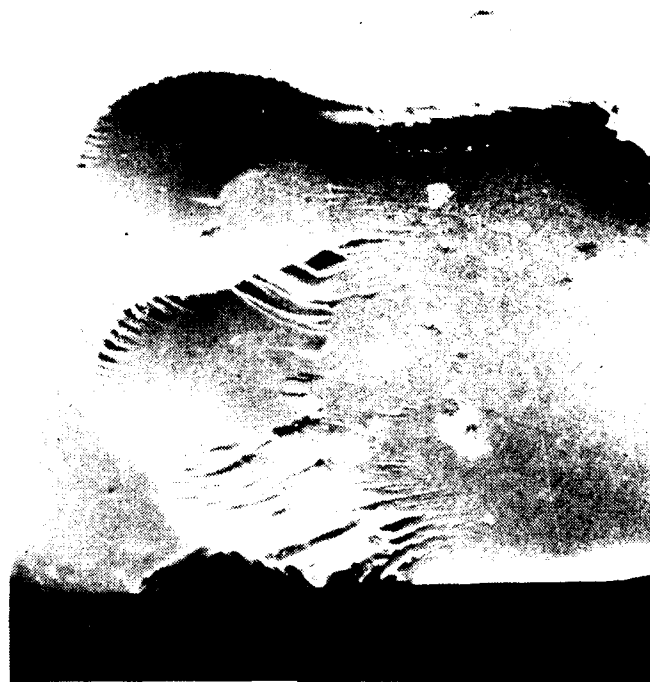

B 10.0 min Rain Exposure

Figure B-8. Vendor B Coated Polycarbonate (1 Yr UV Exposure).

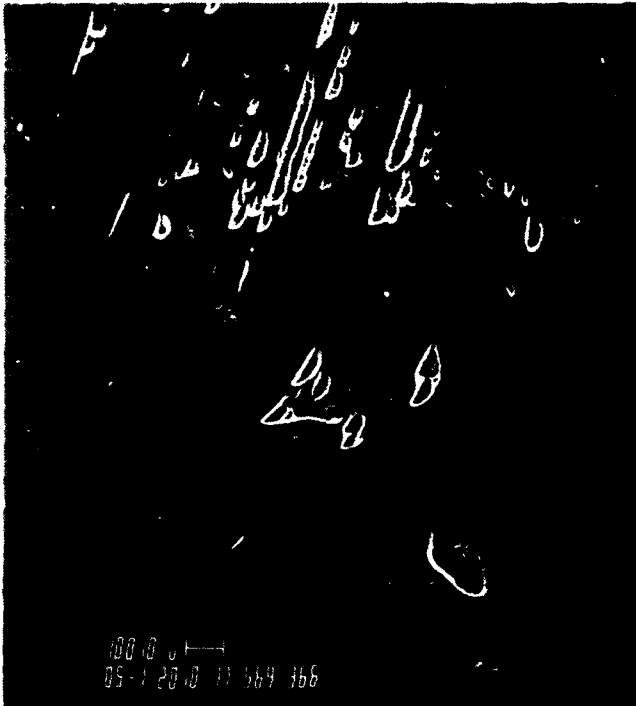

A 1.0 min Rain Exposure



B 1.0 min Rain Exposure



C 5.0 min Rain Exposure



D 10.0 min Rain Exposure

Figure B-9. Vendor B Coated Polycarbonate (3 Yr UV Exposure).

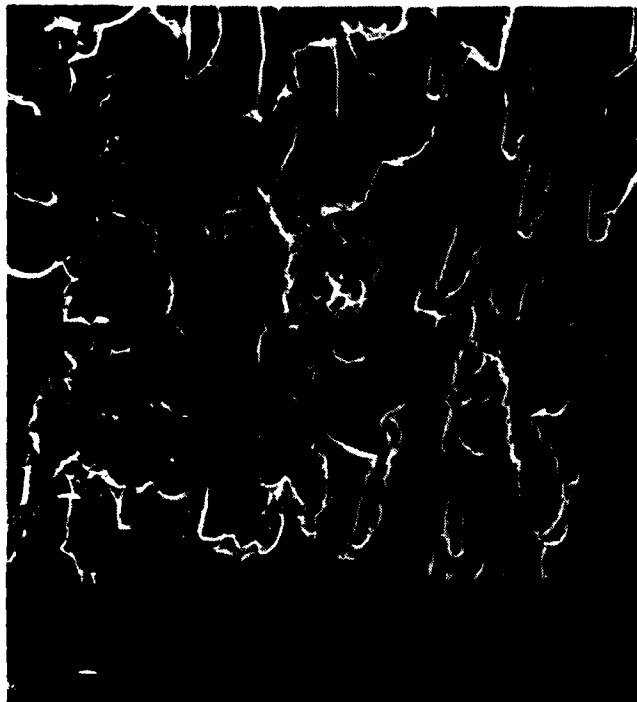

A 1.0 min Rain Exposure 100X



B 1.0 min Rain Exposure 500X



1.0 min Rain Exposure 1000X



D 1.0 min Rain Exposure 3000X

Figure B-10. Vendor P Coated Polycarbonate (3 Yr EMMA).

