

AD-A115 993

FOREIGN TECHNOLOGY DIV WRIGHT-PATTERSON AFB OH
DEVICE FOR THE CONTROL OF FREE-SPINNING MODELS IN A WIND TUNNEL--ETC(U)
MAY 82 L F TEPUV, A S KRYUKOV, M M MIKHAYLOV

F/O 14/2

UNCLASSIFIED

FTD-ID(RS)T-0588-82

NL

1-1
2-1



END
DATE
FORMED
7-82
DTIC

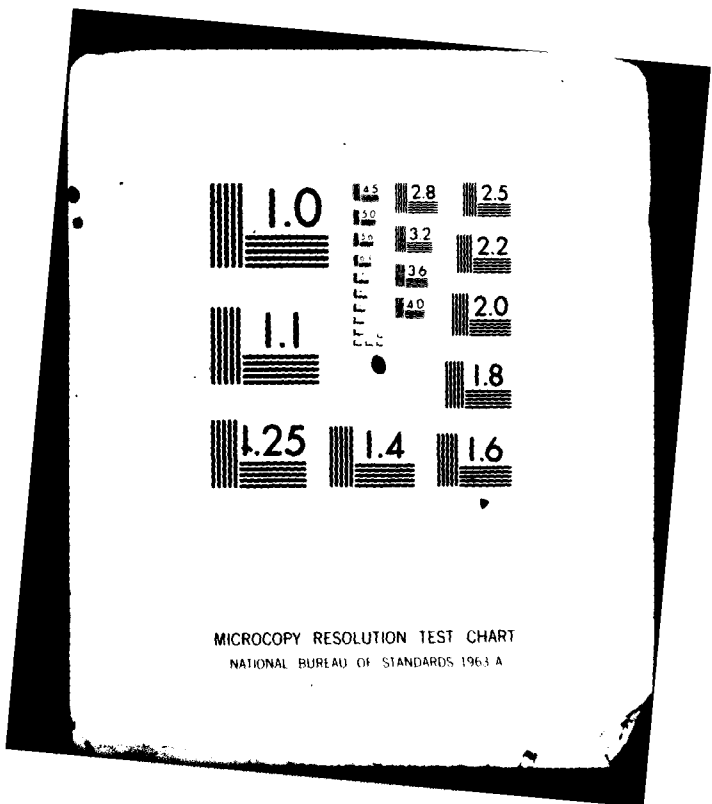

MICROCOPY RESOLUTION TEST CHART
NATIONAL BUREAU OF STANDARDS 1963 A

2

AD A115993

FTD-ID(RS)T-0588-82

FOREIGN TECHNOLOGY DIVISION



DEVICE FOR THE CONTROL OF FREE-SPINNING MODELS
IN A WIND TUNNEL

by

L.F. Teplov, A.S. Kryukov and M.M. Mikhaylov

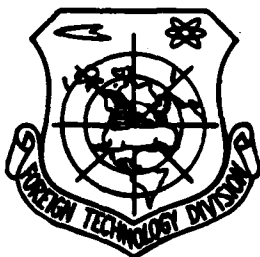

DTIC
ELECTE
S JUN 23 1982 D
E

Approved for public release;
distribution unlimited.



DTIC FILE COPY

3

U. S. BOARD ON GEOGRAPHIC NAMES TRANSLITERATION SYSTEM

Block	Italic	Transliteration	Block	Italic	Transliteration
А а	<i>А а</i>	A, a	Р р	<i>Р р</i>	R, r
Б б	<i>Б б</i>	B, b	С с	<i>С с</i>	S, s
В в	<i>В в</i>	V, v	Т т	<i>Т т</i>	T, t
Г г	<i>Г г</i>	G, g	У у	<i>У у</i>	U, u
Д д	<i>Д д</i>	D, d	Ф ф	<i>Ф ф</i>	F, f
Е е	<i>Е е</i>	Ye, ye; E, e*	Х х	<i>Х х</i>	Kh, kh
Ж ж	<i>Ж ж</i>	Zh, zh	Ц ц	<i>Ц ц</i>	Ts, ts
З з	<i>З з</i>	Z, z	Ч ч	<i>Ч ч</i>	Ch, ch
И и	<i>И и</i>	I, i	Ш ш	<i>Ш ш</i>	Sh, sh
Й й	<i>Й й</i>	Y, y	Щ щ	<i>Щ щ</i>	Shch, shch
К к	<i>К к</i>	K, k	Ъ ъ	<i>Ъ ъ</i>	"
Л л	<i>Л л</i>	L, l	Ы ы	<i>Ы ы</i>	Y, y
М м	<i>М м</i>	M, m	Ь ь	<i>Ь ь</i>	'
Н н	<i>Н н</i>	N, n	Э э	<i>Э э</i>	E, e
О о	<i>О о</i>	O, o	Ю ю	<i>Ю ю</i>	Yu, yu
П п	<i>П п</i>	P, p	Я я	<i>Я я</i>	Ya, ya

*ye initially, after vowels, and after ъ, ь; e elsewhere.
When written as ë in Russian, transliterate as y \ddot{e} or \ddot{e} .

RUSSIAN AND ENGLISH TRIGONOMETRIC FUNCTIONS

Russian	English	Russian	English	Russian	English
sin	sin	sh	sinh	arc sh	sinh ⁻¹
cos	cos	ch	cosh	arc ch	cosh ⁻¹
tg	tan	th	tanh	arc th	tanh ⁻¹
ctg	cot	cth	coth	arc cth	coth ⁻¹
sec	sec	sch	sech	arc sch	sech ⁻¹
cosec	csc	csch	csch	arc csch	csch ⁻¹

Russian English

rot curl
lg log

GRAPHICS DISCLAIMER

All figures, graphics, tables, equations, etc. merged into this translation were extracted from the best quality copy available.

DEVICE FOR THE CONTROL OF FREE-SPINNING MODELS IN A WIND TUNNEL

Invention No. 278176

L.F. Teplov, A.S. Kryukov and M.M. Mikhaýlov

The invention refers to the region of equipment for experimental aerodynamics, in particular, to equipment used in the experimental study of spin in a vertical wind tunnel by means of dynamically similar models of aircraft.

Well-known is a device for the program control of free-spinning models in the experimental study of the spin in a vertical wind tunnel, which consists of a panel for controlling and monitoring connected with the model through a radio channel formed by a stationary transmitter and inductive antenna located around the working section of the tunnel, and also a receiver, actuating mechanisms, connected with control vanes of the model, and sensors [pickups] mounted on the model. The device is imperfect in that the results of the experiment are affected by suspensions of the model; and, furthermore, the transmission of information along the radio channel is unreliable due to the effect of metal weights in the tunnel and the impossibility of obtaining a strict radiation pattern of the antenna.

The purpose of the invention is to eliminate the indicated shortcomings owing to the uncoupling of the model from suspensions in the course of the experiment and the appropriate location of the antennas of the radio channel along the circumference of the tunnel.

Figure 1 shows a block diagram of the described device (stationary and flight subassemblies); on Fig. 2 - the uncoupling unit; Fig. 3 - lock for the uncoupling unit.

The device consists of stationary and flight subassemblies.

The stationary subassembly consists, in turn, of a control panel 1, located inside which are a controller [setter] of the program of tests 2 and, connected with it, a converter 3. Located on the front part of the panel are levers of switches of the set of the program, pushbuttons for starting the program, dumping the program and for feeding the commands manually, light indicators of the transmitted program, sound indicator, which signals the moment of feed of a command, and also other auxiliary pushbuttons and indicators for monitoring the operation of the device. The control panel is connected by a cable with unit 4, located in which are the transmitter 5 with antenna 6, which transmits control signals to the model, and the receiver 7 with antenna 8, which receives response signals from the model about the executed commands.

The flight subassembly, mounted on the model 9, consists of a hidden transponder antenna 10 located in the leading edge of the fin or wing of the model. The antenna is connected by cable with the unit of the flight transponder 11, which in turn is connected with the flight converter 12, power supply source 13, and unit of actuating mechanisms 14.

Installed in the unit of the actuating mechanisms are the contact sensors of position and electromechanical drives to the rudder, elevator, and to the ailerons and counter-spin device.

The uncoupling unit (see Fig. 2) is mounted on the side of the model.

The uncoupling unit consists of the upper 15 and lower 16 locks, which are attached on the upper and lower parts of the fuselage of the model so that the axis I-I passes through the center of gravity of the model, an electromagnetic release device 17, connected with the locks by flexible cables 18, and two sensors: a sensor for disconnecting the suspension with microswitch 19 and a sensor of the suspended state with microswitch 20 (see Fig. 3) installed on the upper lock of the suspension.

Designwise the lock is made in the following way. The fixed part 21 of the housing of the lock is fastened to the model. The

moving part 22 of the housing is connected with the fixed axle 23 and detent [stop] 24. The fixed and moving parts of the housing of the lock and also the dynamometric spring 25 and microswitch 20 form the sensor of the suspended state. Cable 26 of the suspension is attached to a connecting link [shackle] 27, which is connected through a bearing 28 with the rod 29. In the closed position the rod is held by an end stop 30 driven by the cable. Attached to the moving part of the lock housing is the sleeve [bushing] 31 with the spring 32 and push rod 33.

In the position when the model hangs on a cable, the spring 25 is compressed, and contacts of the microswitch 20 are opened. With the onset of the suspended state, the spring presses the moving part of the housing and switches on the microswitch.

On command from the panel through the radio channel, the release device, by means of cables with the end stops, frees simultaneously the rods of the upper and lower locks. The rod is ejected by the push rod with the spring, and here the microswitch 19 actuates and issues a signal for disconnecting the model from the suspension.

For a reliable transmission of information to the model and from the model along the radio communication channel between the stationary and flight subassembly, installed on the model rotating in the spinning mode under conditions of great irregularities of the high-frequency field due to the presence in large metal weights in the wind tunnel, the receiver and transmitter of the stationary subassembly are made two-channel, correspondingly, with two pairs of receiving and transmitting antennas. Each of the pairs is located along the circumference of the tunnel on a straight line which passes through the center, and the indicated straight lines are intersected at an angle of 90° .

Claim of the Invention

1. A device for controlling the free-spinning models in a wind tunnel, which contains a control and monitoring panel, a radio channel of remote control and monitoring, flight [onboard] converters of signals and commands, sensors, and actuating mechanisms, which is

distinguished in that for the purpose of increasing the accuracy of the experiment, it is equipped with a decoupling unit containing two locks fastened to the upper and lower parts of the fuselage of the model along an axis which passes through its center of gravity, an electromagnetic release device formed by an excitation winding and spring-loaded anchor, and a sensor of the suspended state with an electrocontact lead, whereupon the anchor of the release device by means of the flexible cables with ends [tips] is connected with the locks, and its winding is connected through the electrocontact lead of the sensor to the power supply source.

2. A device according to item No. 1, which is distinguished in that for the purpose of the structural joining of the lock and sensor of the suspended state, the lock consists of a fixed part, attached to the model, and a moving part, made in the form of a lever, one arm of which is hinged with the fixed part, and the second arm is connected with the end switch attached to it, the pin of which interacts with the fixed part, is pressed by the spring to the fixed part and through the spring-loaded rod with the shackle is connected to a cable, which holds the model, and the rod is fastened in the channel of the moving part by the end of the cables.

3. A device according to No. 1 which is distinguished in that for the purpose of the reliable transmission of information along the radio channel, it is equipped with two pairs of transmitting and receiving antennas, each of which is located along the circumference of the tunnel on a straight line passing through its center, and the indicated straight lines are intersected at an angle of 90° .

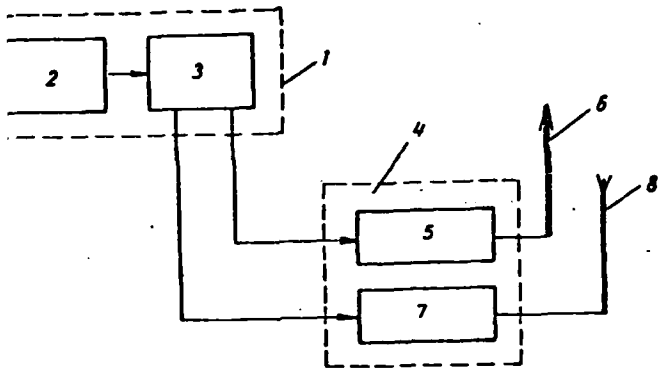
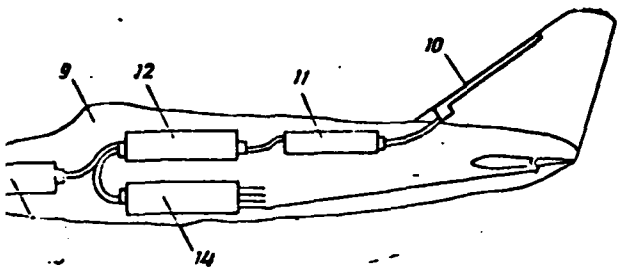

1.

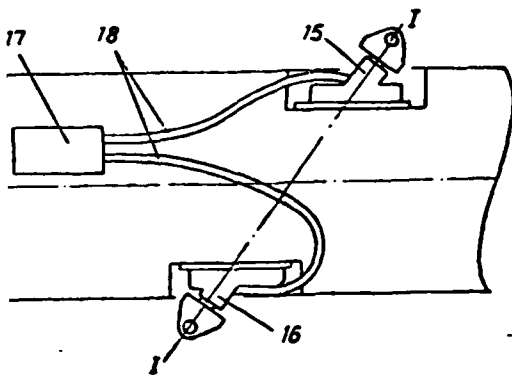

2.

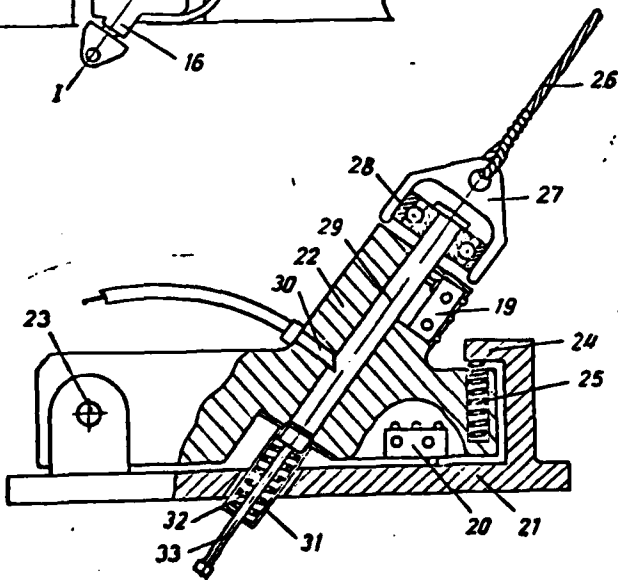

Fig. 3.

