

AD-A116 026

NAVAL AIR DEVELOPMENT CENTER WARMINSTER PA AIRCRAFT --ETC F/6 1/3
THE AIDS/F-18 DIFFRACTIVE HUD.(U)

JUN 82 H GREEN

NADC-82147-60

UNCLASSIFIED

ML

1 of 1

20/20

1

1

1

1

1

1

1

1

1

1

1

1

1

1

1

1

1

1

1

1

1

1

1

1

1

1

1

1

1

1

1

1

1

1

1

1

1

1

1

1

1

1

1

1

1

1

1

1

1

1

1

1

1

1

1

1

END

DATE

FILED

7-82

DTIC

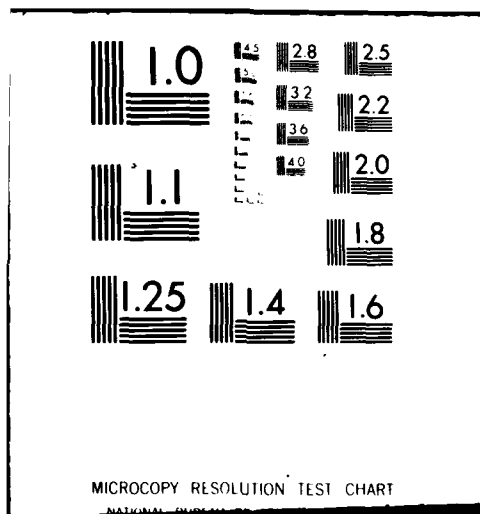

MICROCOPY RESOLUTION TEST CHART
NATIONAL BUREAU OF STANDARDS-1963-A

AD A116026

UNCLASSIFIED

(12)

REPORT NO. NADC-82147-60



THE AIDS/F-18 DIFFRACTIVE HUD (U)

Harold Green
Aircraft and Crew Systems Technology Directorate
NAVAL AIR DEVELOPMENT CENTER
Warminster, Pennsylvania 18974

1 JUNE 1982

Interim Report for Period 1 October 1978-31 March 1982

Approved for Public Release
Distribution Unlimited

Prepared for
NAVAL AIR SYSTEMS COMMAND
Department of the Navy
Washington, D.C. 20361

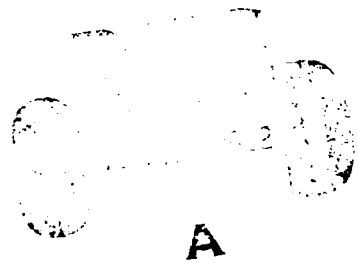

UNCLASSIFIED

82 06 25 021

NOTICES

REPORT NUMBERING SYSTEM – The numbering of technical project reports issued by the Naval Air Development Center is arranged for specific identification purposes. Each number consists of the Center acronym, the calendar year in which the number was assigned, the sequence number of the report within the specific calendar year, and the official 2-digit correspondence code of the Command Office or the Functional Directorate responsible for the report. For example: Report No. NADC-78015-20 indicates the fifteenth Center report for the year 1978, and prepared by the Systems Directorate. The numerical codes are as follows:

CODE	OFFICE OR DIRECTORATE
00	Commander, Naval Air Development Center
01	Technical Director, Naval Air Development Center
02	Comptroller
10	Directorate Command Projects
20	Systems Directorate
30	Sensors & Avionics Technology Directorate
40	Communication & Navigation Technology Directorate
50	Software Computer Directorate
60	Aircraft & Crew Systems Technology Directorate
70	Planning Assessment Resources
80	Engineering Support Group

PRODUCT ENDORSEMENT – The discussion or instructions concerning commercial products herein do not constitute an endorsement by the Government nor do they convey or imply the license or right to use such products.

APPROVED BY: _____

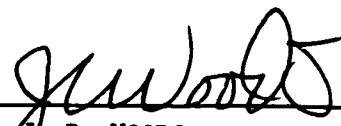
J. R. WOODS
CDR USN

DATE: _____

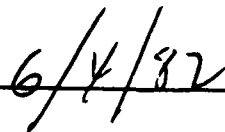

UNCLASSIFIED

SECURITY CLASSIFICATION OF THIS PAGE (When Data Entered)

REPORT DOCUMENTATION PAGE		READ INSTRUCTIONS BEFORE COMPLETING FORM
1. REPORT NUMBER 82147-60	2. GOVT ACCESSION NO. AD-A776026	3. RECIPIENT'S CATALOG NUMBER
4. TITLE (and Subtitle) The AIDS/F-18 Diffractive HUD		5. TYPE OF REPORT & PERIOD COVERED Interim Report Oct 78 to Mar 82
		6. PERFORMING ORG. REPORT NUMBER
7. AUTHOR(s) Harold Green		8. CONTRACT OR GRANT NUMBER(s)
9. PERFORMING ORGANIZATION NAME AND ADDRESS Human Factors Engineering Div (HFE-602) Aircraft and Crew Systems Technology Directorate NADC-Warminster, PA 18974		10. PROGRAM ELEMENT, PROJECT, TASK AREA & WORK UNIT NUMBERS
11. CONTROLLING OFFICE NAME AND ADDRESS		12. REPORT DATE 15 Mar 82
		13. NUMBER OF PAGES 26
14. MONITORING AGENCY NAME & ADDRESS (if different from Controlling Office)		15. SECURITY CLASS. (of this report) UNCLASSIFIED
		15a. DECLASSIFICATION/DOWNGRADING SCHEDULE
16. DISTRIBUTION STATEMENT (of this Report) APPROVED FOR PUBLIC RELEASE; DISTRIBUTION UNLIMITED		
17. DISTRIBUTION STATEMENT (of the abstract entered in Block 20, if different from Report)		
18. SUPPLEMENTARY NOTES		
19. KEY WORDS (Continue on reverse side if necessary and identify by block number) Head-Up Display, Diffractive Optics, Holographic Combiner Advanced Integrated Display System (AIDS)		
20. ABSTRACT (Continue on reverse side if necessary and identify by block number) This report describes Head-Up displays, their development, performance characteristics, and the NADC AIDS/F-18 diffractive HUD description with comparative performance.		

DD FORM 1473
1 JAN 73

EDITION OF 1 NOV 65 IS OBSOLETE
S/N 0102-LF-014-6601

UNCLASSIFIED

SECURITY CLASSIFICATION OF THIS PAGE (When Data Entered)

Contents

	<u>Page</u>
1.0 Introduction	1
2.0 System Description	4
3.0 Current Status	10
4.0 Associated Documentation	10
5.0 Preliminary AIDS HUD Utilization Plan	10
6.0 Future Plans	10
I - Near-Term	10
II - Mid-Term	13
III - Far-Term	13
7.0 Report	13
I - Head-Up Display (HUD) - Definition	13
II - Refractive HUD	13
III - Diffractive HUD	15
IV - Reliability and Maintainability (R&M) Considerations of a DHUD	17
V - Flare	18
VI - Summary	19
VII - References	21

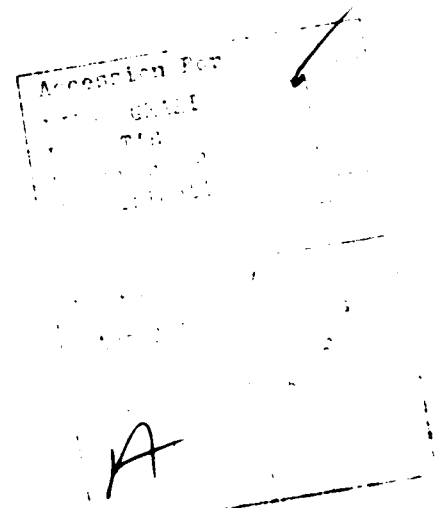

List of Illustrations

<u>Figure</u>		<u>Page</u>
1A	F-18/AIDS HUD Instrument Panel Mock-up	2
1B	F-18/AIDS HUD Instrument Panel Mock-up	3
2	AIDS (F/A-18) HUD	4
3	AIDS HUD Elements	5
4	Elements of Diffraction Optics HUD	5
5	AIDS Head-Up Display	6
6	AIDS Head-Up Display Demonstration	7
7	HUD Field of View	8
8	AIDS F/A-18 HUD Optical Element Characteristics	9
9	AIDS F/A-18 HUD Optical System Characteristics	9
10	Layout-AIDS HUD	11
11	Preliminary AIDS HUD Utilization Plan	12
12	HUD System-Typical Cockpit Installation	14
13	Refraction HUD	14
14	Principal Components of a Diffractive Optics HUD	15
15	Brightness vs. Current Density for Various Phosphors	17
16	HUD Performance Comparison Between F-18 HUD, and AIDS/F-18 HUD	20

1.0 Introduction

The Human Factors Engineering Division (HFE) of the Aircraft and Crew Systems Technology Directorate (ACSTD) at the Naval Air Development Center (NADC) is currently engaged in the evaluation of a diffractive optics Head-Up Display (HUD).

This Advanced Integrated Display System (AIDS) HUD employs a state-of-the-art diffraction-optic or holographic combiner, and represents the first such system configured for use in a high performance Naval aircraft (F/A-18).

The Hughes Aircraft Co. (HAC) of El Segundo, Cal., under the technical direction of HFE at NADC, has developed the AIDS HUD in a three year incremental effort commencing October 1978.

The HUD equipment delivered under Contract N62269-78-C-0232 consisted of one pilot's display unit (PDU), a spare holographic combiner, and a spare CRT/deflection yoke.

Another deliverable received under this contract was a mock-up of the F-18 cockpit flight control/instrument panel and AIDS' HUD with its wide field-of-view combiner. Figures 1A and 1B.

The AIDS/F-18 Diffractive Optics HUD, Figure 2, is a unique type of Head-Up Display which employs diffractive optics in its combiner rather than conventional refractive optics.

The diffractive optic approach represents a major advance in optical performance over that of a conventional system, particularly from the standpoint of angular field-of-view and display brightness.

The diffractive optics combiner is analogous to a wavelength sensitive mirror with lens-like optical magnification or power. These qualities permit efficient reflection of display symbology while simultaneously transmitting most of the external world illumination (high transmissivity), and make possible a large instantaneous binocular field of view (FOV).

The diffractive property of this combiner is contained in a transparent dichromated gelatin film which is sealed within the glass substrate and cover glass of the combiner.

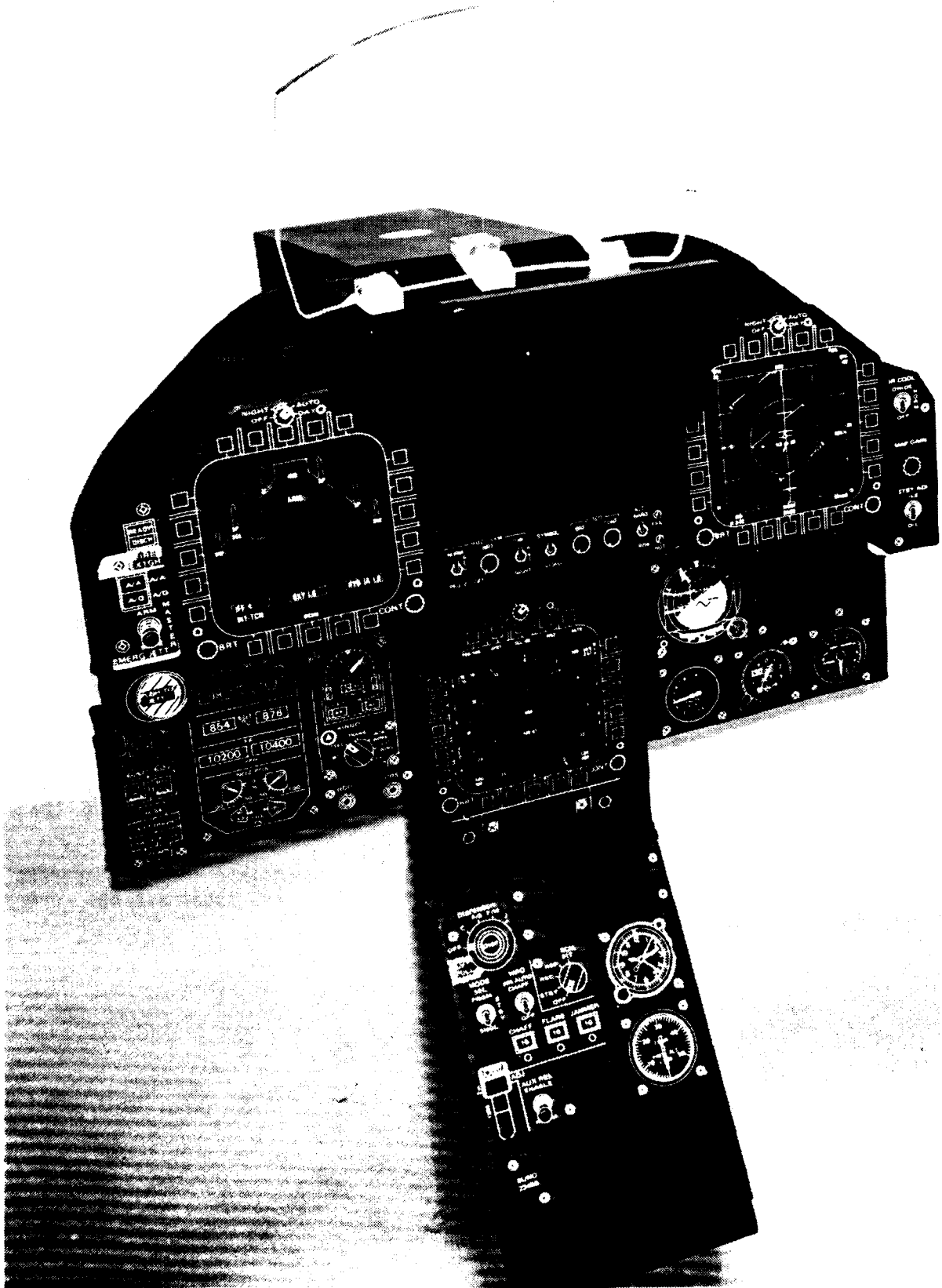

Figure 1A. F-18/AIDS HUD Instrument Panel Mock-up
2

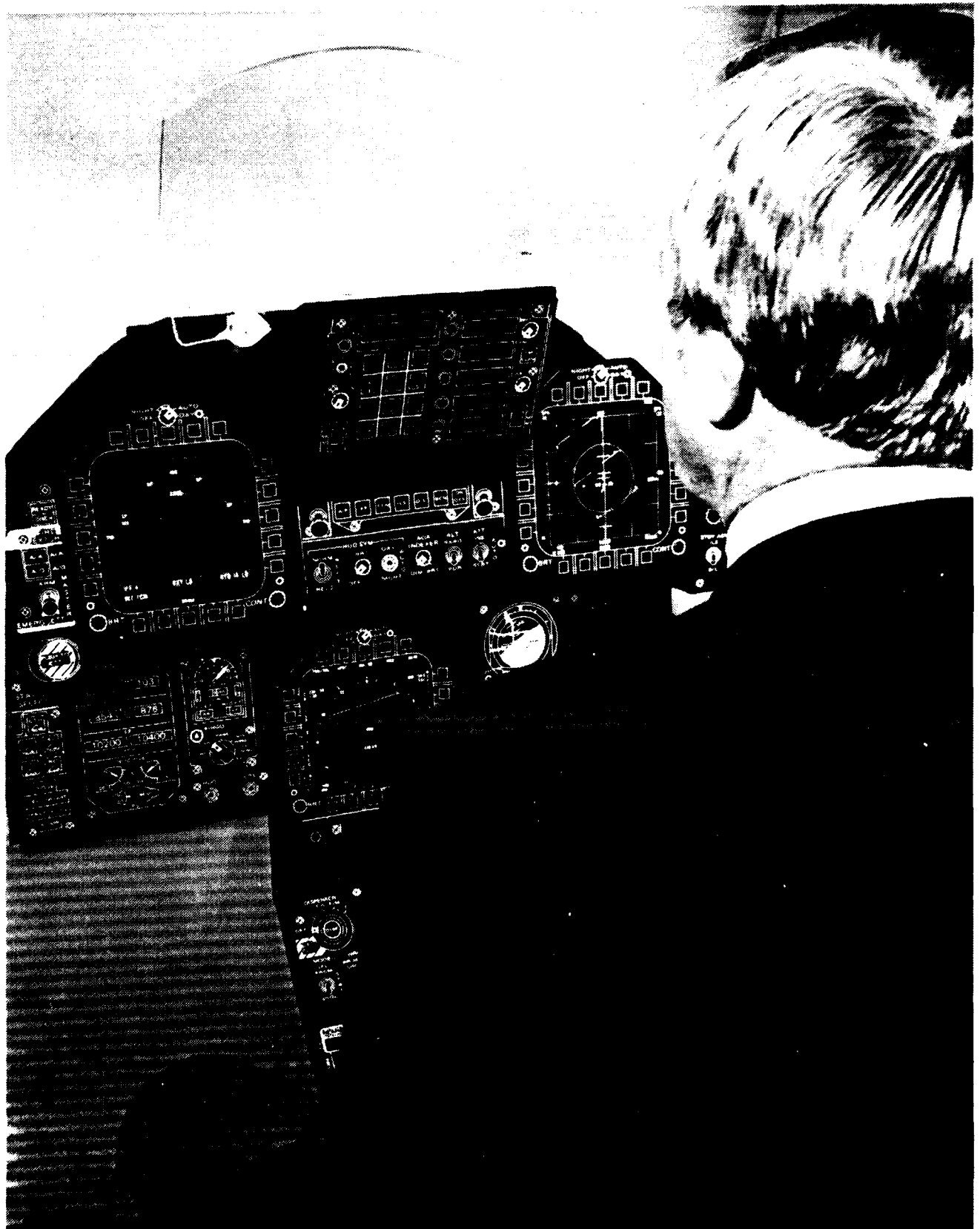

Figure 1B. F-18/AIDS HUD Instrument Panel Mock-up

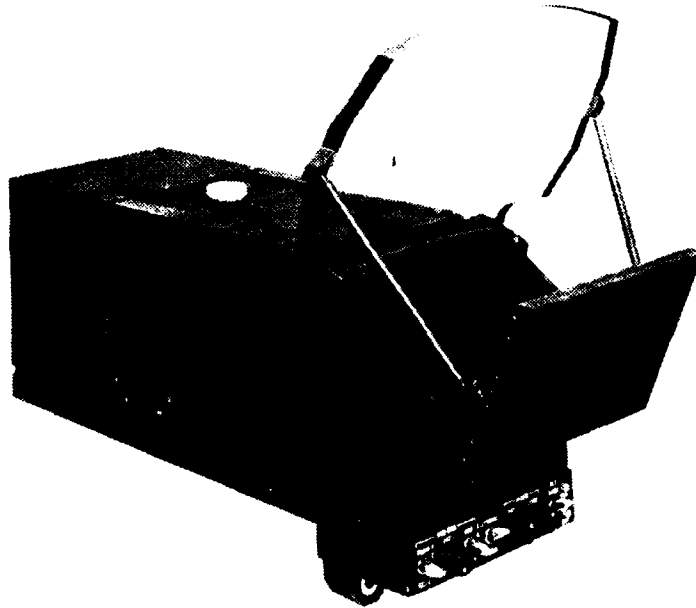

Figure 2. AIDS (F/A-18) HUD

2.0 System Description

The system block diagram of the AIDS HUD, also known as the pilot's display unit (PDU), is shown in Figure 3.

The PDU consists of a subassembly which houses the cathode ray tube and deflection yoke, relay lens assembly, folding mirror/sun band pass filter, and diffraction optic lens/combiner shown in Figures 3 and 4.

Other components of the PDU include high and low voltage power supplies (HVPS, LVPS), light sensor for automatic brightness control, ancillary and display electronics, and AIDS HUD control panel (power on/off, day/night viewing mode, HUD symbology brightness, video brightness, video contrast, symbology/video switch). See Figures 5 and 6.

The display brightness, although manually controlled, is automatically controllable to maintain a 1.4 contrast ratio in the presence of varying background light levels.

The AIDS HUD field of view (FOV) in comparison to F/A-18 HUD FOV is illustrated in Figure 7.

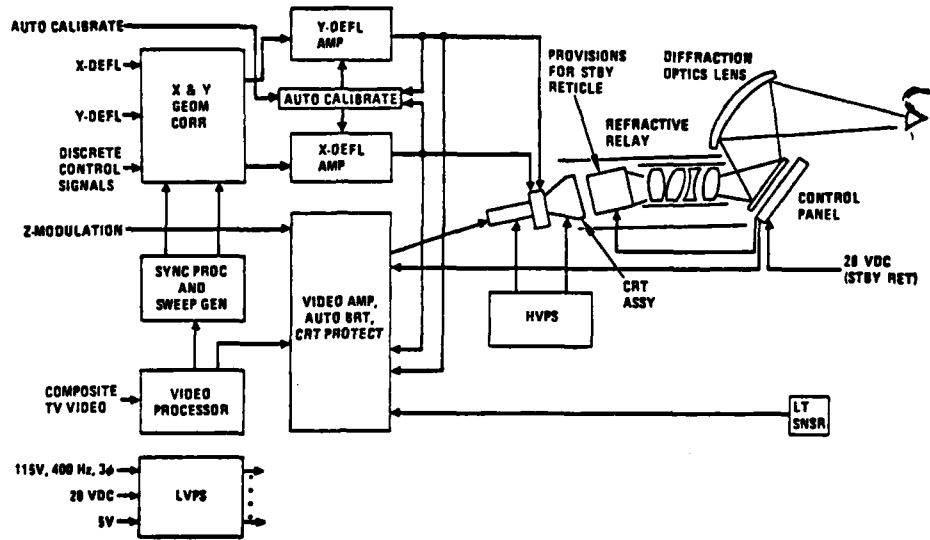

Figure 3. AIDS HUD Elements

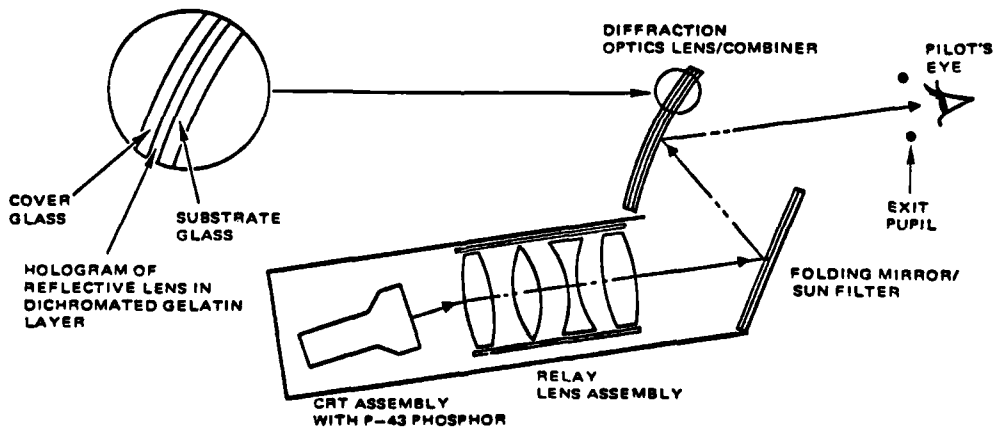

Figure 4. Elements of Diffraction Optics HUD

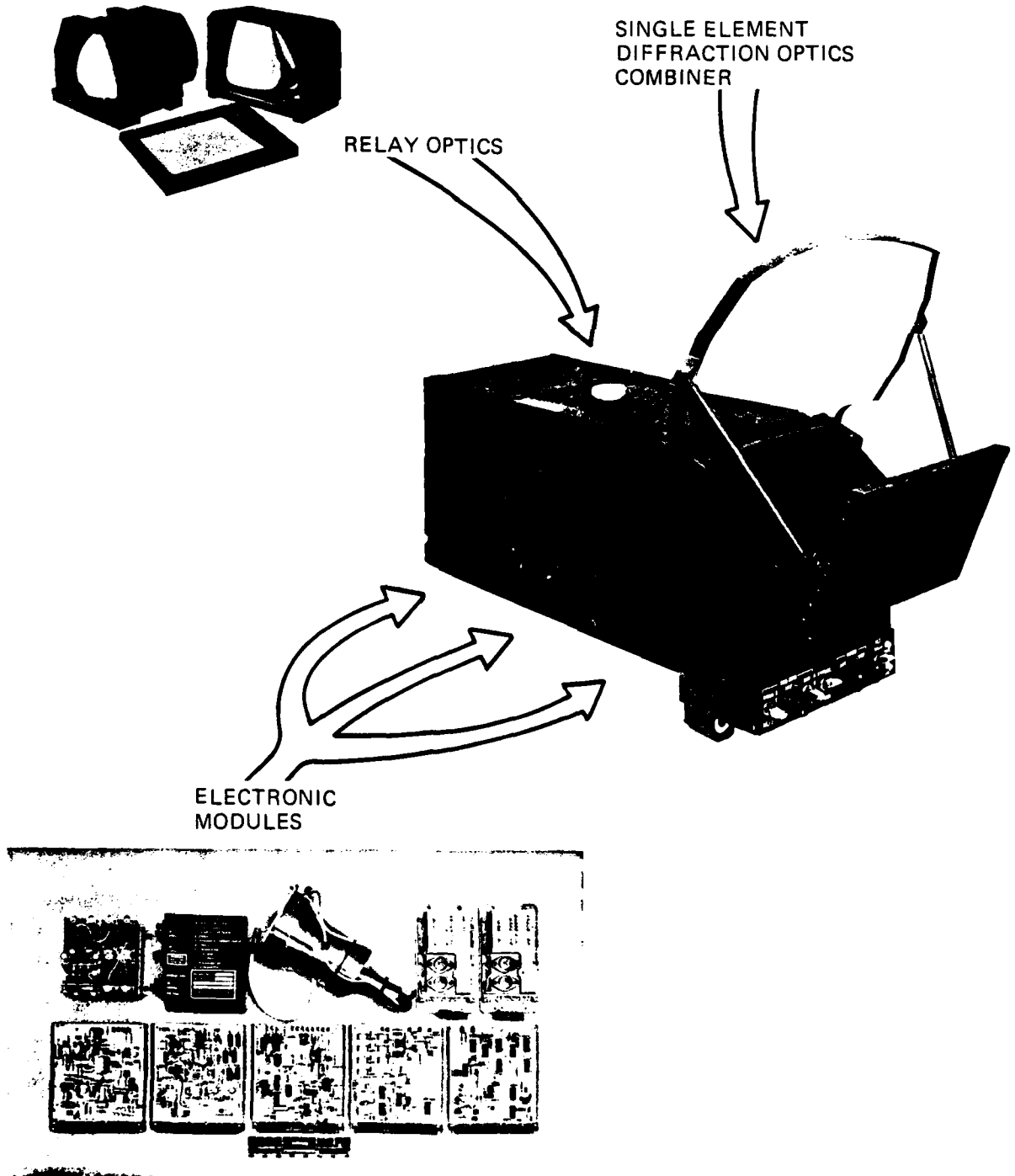

Figure 5. AIDS Head-Up Display

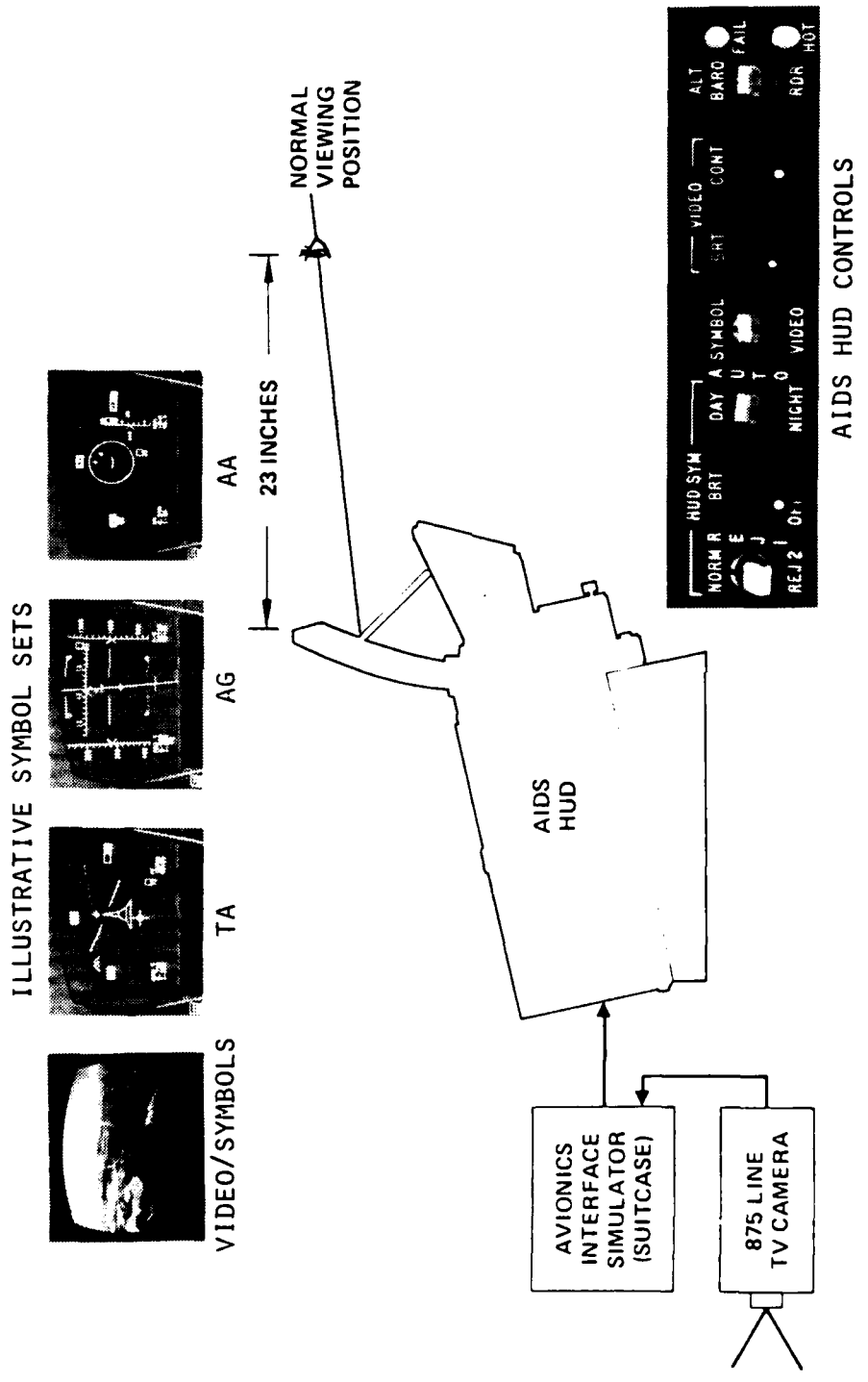

Figure 6. AIDS Head-Up Display Demonstration

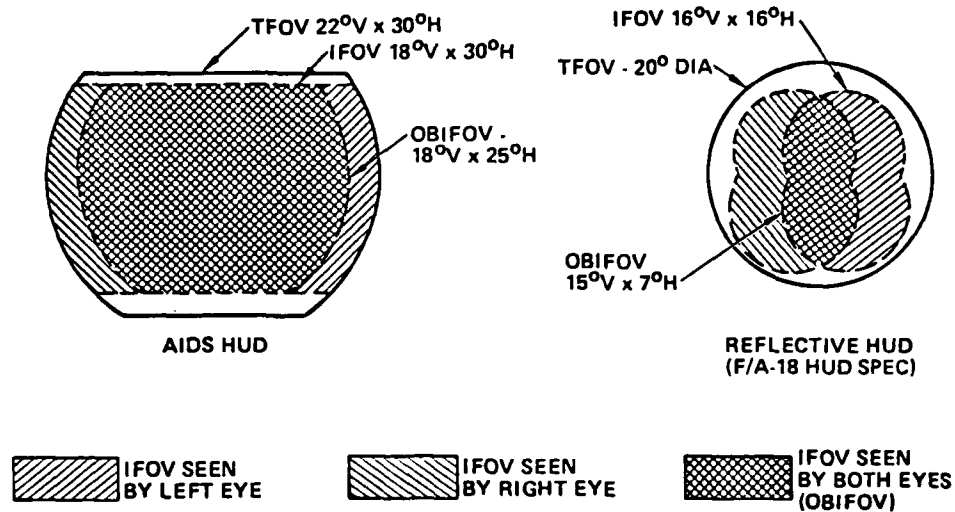

Figure 7. HUD Field of View

The optical element characteristics of the combiner and relay lens assembly are shown in Figure 8.

The AIDS HUD system optical performance characteristics are shown in Figure 9.

The AIDS HUD is designed to interface with the onboard F-18 symbol generator. In order to compensate for FOV differences between the F-18 HUD and the AIDS HUD, software interface discrepancy compensation in scaling, registration and video is presented to the F-18 symbol generator on the wide FOV AIDS HUD.

The AIDS HUD can be demonstrated independently using a 60 cycle, 110 V source employing the Hughes' Avionics Interface Simulator and a 525/875 line TV camera.

Modes selectable by the portable demonstrator include stroke symbology alone (navigation, terrain avoidance, air-to-ground, and air-to-air), video raster alone, and stroke symbology superimposed over video (one mode). See Figure 5.

The AIDS DHUD has been designed to interface with the other display elements of AIDS and F-18 avionics via a MIL-STD-1553A digital multiplex system and a wideband multiplex system. Inputs from the digital multiplex system control the symbol generation process. The digital multiplex system is utilized for start up/utilization commands to the HUD, mode selection (stroke or raster), and for status/BITE reporting to the HUD.

COMBINER

BEND ANGLE	46 DEG.
FOCAL LENGTH	10 IN.
F-NUMBER	2.32
RADIUS	20 IN.
SIZE	11.5 X 8.7 IN. (APPROX.)

RELAY LENS ASSEMBLY

FIELD OF VIEW	45 DEG.
F-NUMBER	0.74
WIDTH	4.7 IN. (APPROX.)
LENGTH	6.5 IN. (APPROX.)

Figure 8. AIDS F/A-18 HUD Optical Element Characteristics

HORIZONTAL FIELD OF VIEW

TOTAL	30 DEG.
INSTANTANEOUS	30 DEG.

VERTICAL FIELD OF VIEW

TOTAL	20 DEG.
INSTANTANEOUS	18 DEG.

EXIT PUPIL SIZE 4.3 X 3.0 IN.

EXIT PUPIL TO COMBINER 24 IN. (APPROX.)

CRT DIAMETER 3.0 IN.

SYSTEM F-NUMBER 1.20

Figure 9. AIDS F/A-18 HUD Optical System Characteristics

3.0 Current Status

The AIDS/F-18 HUD is currently being evaluated in the Manned Air Combat Simulator (MACS) at McDonnell Douglas Corporation, St. Louis, MO. It is planned that the HUD will be installed in an F/A-18 aircraft for a limited flight test evaluation in the 1982 time period.

Subsequently, the HUD will be returned to the Crew Station Evaluation Facility (CREST) at NADC for human factors evaluation in developing advanced HUD concepts.

4.0 Associated Documentation

Documentation received from the contractor, (HAC) under this contract consisted of:

- (1) Test Vehicle Installation (T.V.I.) Inspection
- (2) Inspection/Test Report
- (3) Program Quality Requirements
- (4) Environmental Test Procedure and Test Results
- (5) AIDS HUD Combiner Test Procedure and Test Results for Combiner #MTA-4C.
- (6) Acceptance Test Procedure (ATP) for the Advanced Development Model (ADM) HUD for the Advanced Integrated Display System (AIDS) and Test Results
- (7) Engineering Drawings (Commercial)
Mechanical & Electrical (assemble, test, & troubleshoot)
- (8) PDU-Installation Control Dwg AIDS HUD
- (9) Advanced Development Model (ADM) Specification for the AIDS HUD
- (10) AIDS HUD Mount Test Stand
- (11) AIDS HUD Interface Control Document
- (12) Combiner Specifications, AIDS HUD
- (13) Layout - AIDS HUD (Figure 10)

Documentation pending from the contractor are:

- (1) Final Report*

*This report has been postponed to 1 September 1982 in order to permit inclusion of simulation and flight test data.

5.0 Preliminary AIDS HUD Utilization Plan

(See Figure 11)

6.0 Future Plans

I. Near-Term

Near-Term future plans for the AIDS HUD include an interim HUD support program. This program would be a field engineering type project in which the contractor, HAC, would assist MCAIR in integration of the HUD with the Manned Air Combat Simulators (MACS 3.0 and 3.5 simulators). MACS 3.0 is a

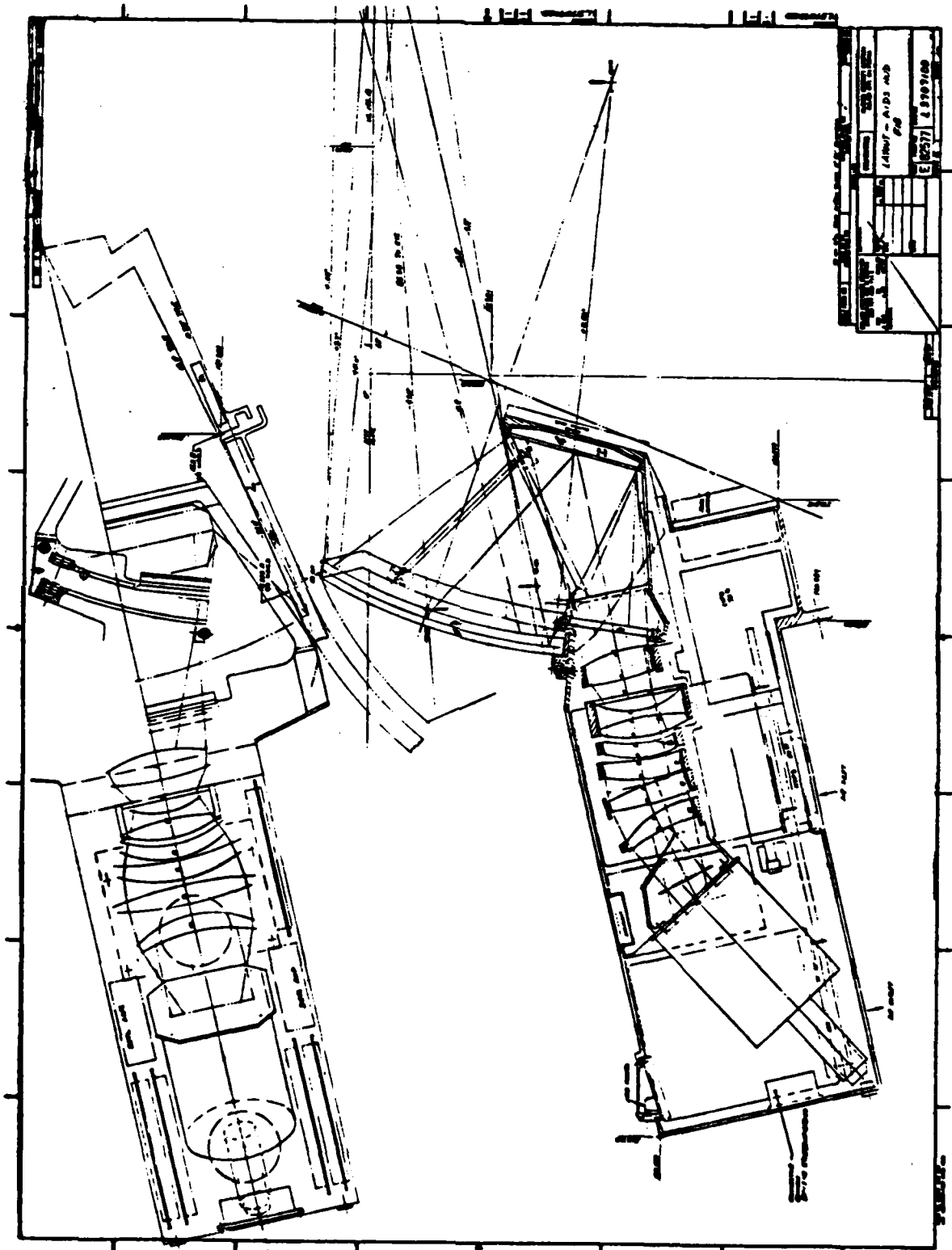
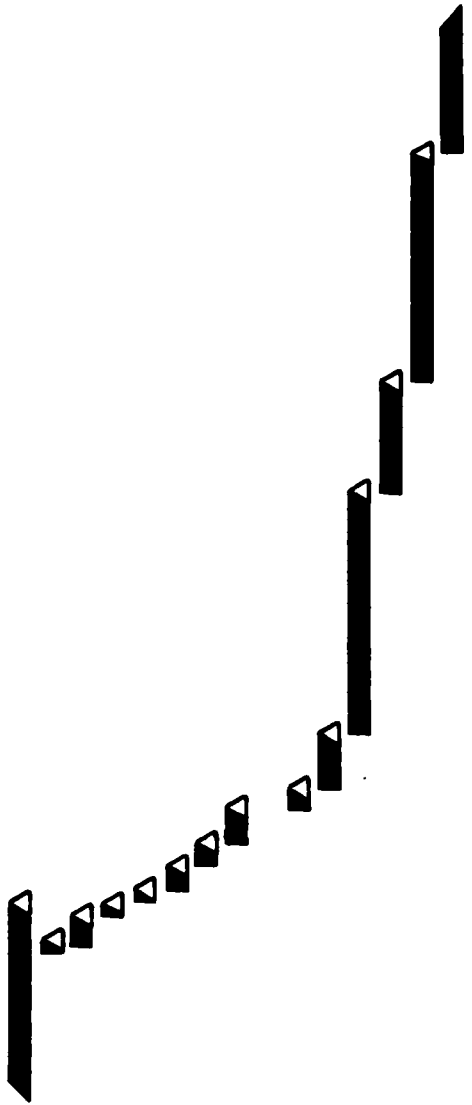

Figure 10. Layout-AIDS HUD

'81 J A S O N D J F M A M J J A S O N D J F M A M J J A '82 '83

1. FAB. ASS'Y C/O AND TEST ENVIRONMENTAL TEST (PETE CART) FINAL O.C.. CLEANUP FACTORY ACCEPTANCE & BURN-IN SHIP TO NADC
2. NADC ACCEPTANCE & DEMO. °
3. MCAIR BENCH TESTS
4. F/A-18 SYST. INTEG. TESTS (MACS 3.5, MACS 3)
5. F/A-18 A/C INTEGRATION
6. F/A-18 "QUICK LOOK" FLIGHT TEST
7. ADV. F/A-18 SYST. DEVEL. (MACS 3)
8. ADV. F/A-18 FLIGHT TEST
9. AIDS SYSTEM INTEG. & DEV.
10. AIDS FLIGHT TEST



°RECOMMENDED DEMONSTRATIONS: NADC, NAVAIR, F/A-18 SPO, NAVMAT, AFML, AERE, LANTIRN SPO, F-15 SPO, MCAIR, G.D., FAIRCHILD

Figure 11. Preliminary AIDS HUD Utilization Plan

simulator consisting of rack mounted factory test and commercial equipment while MACS 3.5 is the simulator consisting of actual F-18 aircraft avionics interfacing physically and electrically with the HUD.

HAC would also assist in the HUD integration with the F/A-18 flight test vehicle, provide spare parts and routine maintenance, planning of the flight tests, and conduct an evaluation of the flight test results.

The Near-Term future plan should be completed by 31 December 1982.

II. Mid-Term

Mid-Term future plans could include an AIDS HUD Control/Display panel. This would consist of an effort to provide additional controls and a 3" x 4" solid state matrix display in the Up Front Control Panel (UFCP) location on the back of the AIDS HUD. A small electronics unit would be included to interface these functions with the avionics bus.

The actual flat-panel display technology has not as yet been established. However, the program would include evaluation of limited display samples in the AIDS HUD near-term flight test.

III. Far-Term

A Far-Term future plan might include an effort to develop a recording system for the AIDS HUD. Because of the geometry involved in the wide FOV AIDS HUD, a visual obscuration is encountered by a HUD camera probe.

A satisfactory trade-off would be to move the camera forward of the combiner and electronically combine the symbols with the camera video.

The basic task then is to take analog X, Y, and Z signals, and convert them into the raster format for synchronization with the HUD recording camera. It would be assumed that an actual video tape recorder would be utilized.

7.0 Report:

I. What is a Head-Up Display or HUD?

The Head-Up Display or HUD is an electro-optical instrument that displays flight information of several selectable modes in a collimated form so that the pilot can view this information superimposed on the outside world without having to change his/her line of sight or visual accommodation.

Selectable modes may include take off, navigation, landing, weapons delivery, terrain following, etc.

The HUD is hard-mounted to the airframe and boresighted to the Armament Datum Line (ADL) of an aircraft (Figure 12).

II. Refractive HUD

Essential features of a refractive or conventional HUD consist of a cathode ray tube (CRT) with a wide band spectral phosphor such as P1, or P20, or P31, etc., a folding mirror, collimating lens, and a flat combiner (Figure 13).

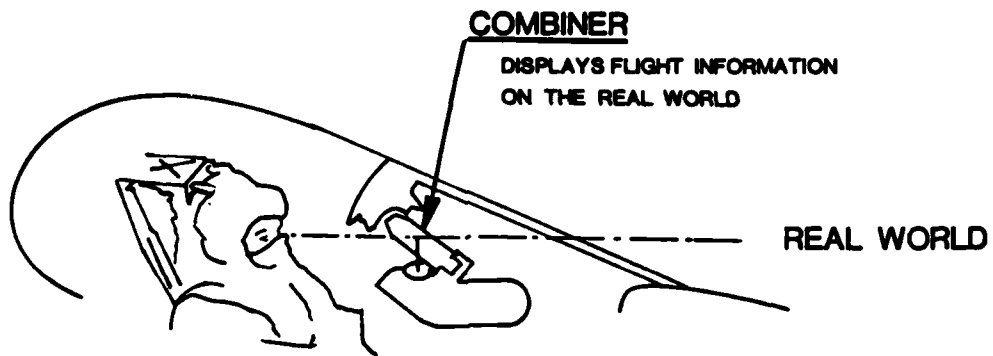

Figure 12. HUD System - Typical Cockpit Installation

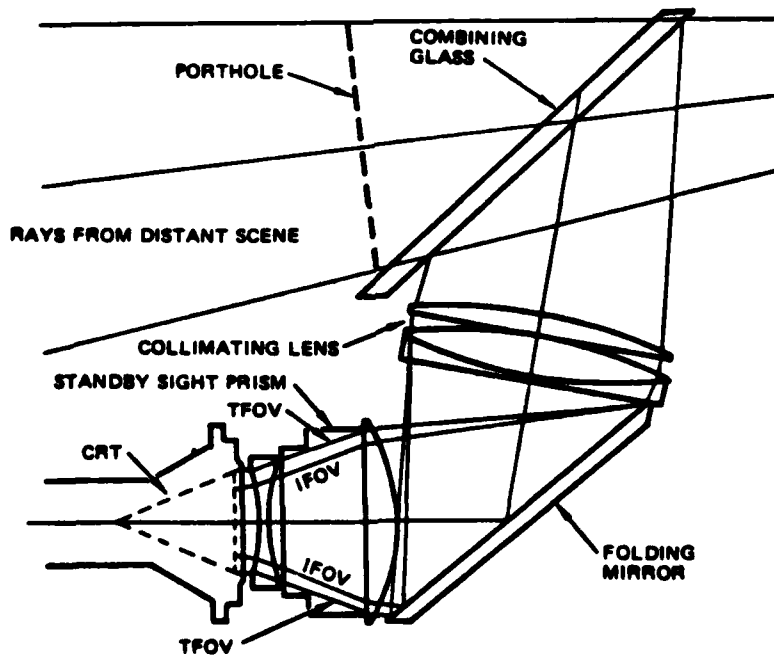

Figure 13. Refraction HUD

The folding mirror reflects symbology off the CRT into the collimating lens. The collimating lens receives divergent light rays of the CRT image and renders them parallel. A flat combiner or beam splitter reflects the collimated image into the pilot's forward FOV.

The instantaneous field of view (IFOV) is equal to the flat area of the collimating lens. The total field of view (TFOV) is equal to the magnification size of the CRT faceplate as imaged through the optical system.

The IFOV is somewhat smaller than the TFOV. The pilot by moving his/her head in various positions is able to see the TFOV.

The combiner in a refractive HUD is responsible for the largest share of light loss in the optical system. Its reflectivity is typically 25% while its see-through transmission is 75%.

The typical light efficiency of a refractive HUD from CRT to the pilot's eyes is approximately 16%.

III. Diffractive HUD

Distinguishing features of a diffractive HUD, (DHUD) are a high-gain, narrow bandwidth P43, or P44, or P53 phosphor CRT, a folding mirror, and a concave aspheric combiner which also serves as a collimating element (Figure 14).

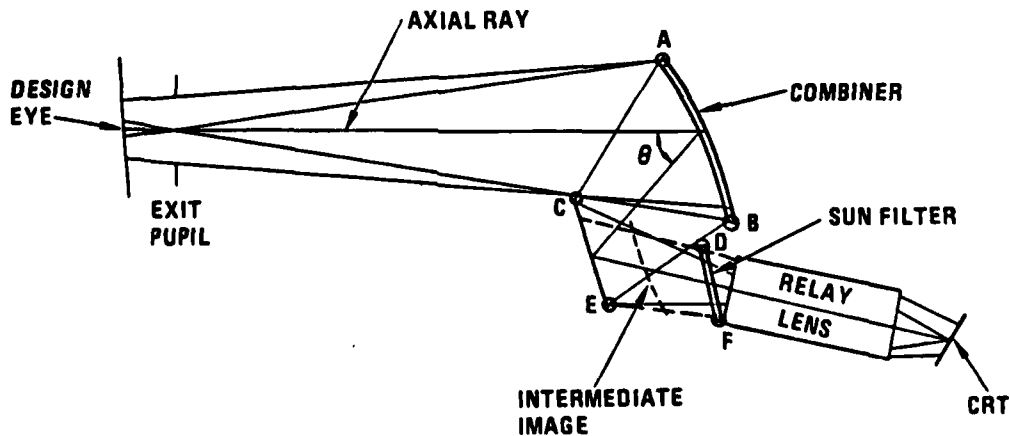

Figure 14. Principal Components of a Diffractive Optics HUD

The DHUD employs a pupil-forming system in which symbology from the CRT is relayed by lenses to form an intermediate image in space at the focal plane of the combiner. The combiner is used as an eyepiece to provide a collimated image of the CRT face plate. The exit pupil is formed at the pilot's nominal eye position and is the magnified image of a real aperture stop located in the relay lens. The TFOV display can be viewed from any point within this exit pupil.

The DHUD uses a holographic optical element (HOE) in its wide angle combiner. The HOE is a thin, invisible, dichromated gelatin, diffractive grating film located on the glass substrate of the combiner-collimator. The HOE is hydroscopic, baked, and protectively covered and sealed by a glass cover plate. The glass cover plate, in turn, has an anti-reflection coating to enhance optical performance.

The DHUD contains a high-gain, narrow bandwidth P-43 phosphor CRT, whose response spectrum is matched by the diffractive (reflective) characteristics of the HOE. The DHUD combiner has a diffractive efficiency of 80%, while its see-through property is 85%. The typical light efficiency of a DHUD from CRT to the pilot's eyes is approximately 48 to 50%. Accuracies recently measured during acceptance testing were 0.4mr at the center and 2.9mr 10° off axis (near edge).

Because of the DHUD's high diffractive/reflective efficiency (80%), stroke symbology superimposed over 525/875 line TV/FLIR sensor video raster is obtainable under subdued environmental lighting. Up to 14 shades of gray under the same conditions are obtainable in the raster display.

The IFOV is larger in a DHUD than in a refractive HUD because the collimating elements are no longer lenses inside the confines of the HUD but exist as the large aspheric reflective surface of the collimating combiner outside the confines of the HUD.

The collimating combiner in a DHUD subtends a larger visual angle than the collimating lenses in a refractive HUD which makes the IFOV larger. This is so because the collimating element (combiner) is larger and closer to the eye than the collimating element (collimating lens) in a refractive HUD.

The combiner in a DHUD both collimates and reflects the CRT symbology into the pilot's FOV. The relay lens also compensates for the aberrations induced by the Bend angle θ (Figure 14). The Bend angle is the angle formed on the combiner's inside aspheric concave surface by the intersection of the visual axis from the design eye position and the chief ray from the center of the CRT faceplate. The greater this Bend angle, the greater the aberrations the relay lens is required to correct. The Bend angle for the AIDS/F-18 combiner is 46°.

In a DHUD, the IFOV is almost as large as the TFOV. The IFOV in the AIDS/F-18 DHUD is 18°V x 30°H, while its TFOV is 22°V x 30°H. The pilot sees almost all of the TFOV without changing his head position, which is typically 1 1/2 to 2 times as large as the IFOV in a refractive HUD.

See-through transmission of the AIDS/F-18 DHUD is 85% while in the refractive HUD see-through transmission is typically 70%.

IV. Reliability and Maintainability (R&M) Considerations of a DHUD

Although actual operational information is presently unavailable on R&M statistics for DHUDs, one can logically predict the life extension property of operating the CRT at a lower beam intensity because of the more efficient optical projection systems.

Referring to Figure 15, one can determine that CRT phosphors are more efficient at lower CRT beam currents than at higher ones (before saturation takes effect).

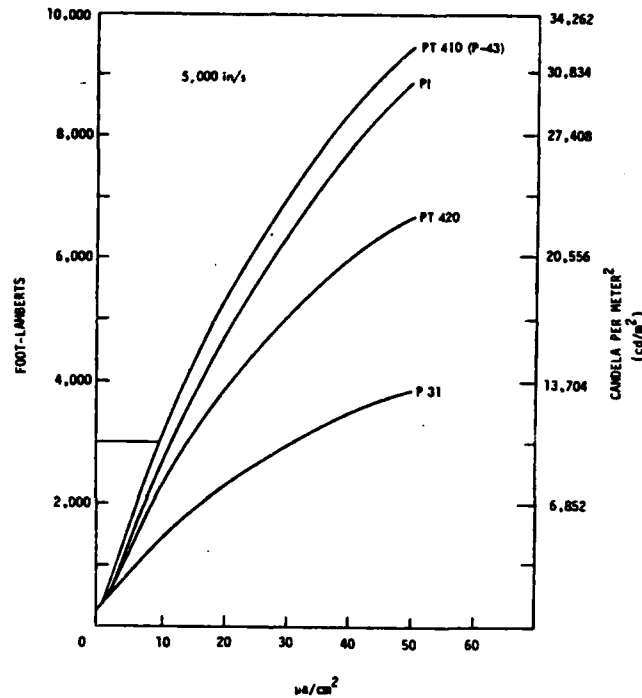

Figure 15. Bright vs. Current Density for Various Phosphors

The advantage gained by using lower beam currents is non-linear. The increased life expectancy of the CRT is a function of the product of reduced beam current and the increased optical efficiency using a diffractive optics combiner in reflecting CRT imagery over the decreased efficiency of a conventional beam splitting combiner times the increased CRT beam current.

An example of this relationship can be illustrated by using Figure 15. The most efficient phosphor in the figure is P-43. For a light output of 9000 foot lamberts ($30,834 \text{ cd}/\text{m}^2$), a current density of $45 \mu\text{ amps}/\text{cm}^2$ is required.

The brightness advantage in using diffractive optics in the combiner is about 3.5 to one. For example,

$$\frac{\text{Diffractive combiner efficiency}}{\text{Refractive combiner efficiency}} = \frac{80\%}{25\%} = 3.4$$

or

$$\frac{\text{Diffractive system efficiency}}{\text{Refractive system efficiency}} = \frac{50\%}{16\%} = 3.13$$

Conservatively, if a 3 to 1 advantage is applied to the same phosphor such that only one-third (1/3) of the brightness is required at the CRT, i.e., 3,000 foot lamberts, the required current density is 10 μ amps/cm² or about 22% of that required to produce the higher brightness, i.e.,

$$\frac{10 \mu\text{a/cm}^2}{45 \mu\text{a/cm}^2} \times 100 = 22\%$$

A relative life expectancy of four and one-half (4 1/2) could be realized, i.e.,

$$\frac{45 \mu\text{a/cm}^2}{10 \mu\text{a/cm}^2} = 4.5$$

V. Flare

Prior to correction, the diffractive HUD was susceptible to both image and chromatic flare (secondary images) when viewing point sources of light (runway lights) in a dark surrounding (at night).

A dual laser beam approach previously used in the manufacturing process of the HOE developed secondary holograms in the diffractive element. Stray reflections from optical components and mounts in the laser paths found their way to the diffractive element and caused secondary hologram (reflective holograms) formations during the exposure sequence.

Through the use of a single beam exposure technique in which the laser beam is reflected from an aspheric concave mirror surface located behind the HOE and also intersects the same oncoming laser beam on the HOE which is located in an oil cell, many secondary holograms are eliminated, some are reduced, and flare is minimized.

So long as lens power for collimation is required in the diffractive combiner, some small amount of flaring will be present.

If the secondary flare can be reduced to one-hundredth (2 orders of magnitude) or less in brightness to the primary image, the flare should be tolerable and present little problem.

Combiner flare measurements made during the acceptance test procedure (ATP) of the diffractive HUD using a He Ne laser was 0.05% in the first order beam, i.e.,

$$\frac{\text{First order diffractive beam location}}{\text{Zero order diffractive beam location}} = \frac{0.003 \text{ ft}^1}{6.3 \text{ ft}^1} \times 100 = 0.05\%$$

The ratio of secondary to primary image brightness is 5×10^{-4} which is closer to 4 orders of magnitude difference and should be quite tolerable.

VI. Summary

The design considerations for selecting a diffractive optics lens system rather than a refractive lens system in a HUD should be:

- Increased FOV
- Improved HUD viewability
- More reliable operation
- Lower life cycle cost

In the realm of display performance, a diffractive optics lens system should permit the following:

- Extended off boresight coverage, enhancing target acquisition and designation, attack and landing modes.
- Simultaneous air-to-air and air-to-ground coverage without switching or adjustment
- Reduced pilot's head movements and fewer physical constraints on the pilot
- Reduced display clutter
- Additional peripheral symbology
- Television raster (FLIR/LLTV), stroke superimposed over raster during refresh cycle
- Increased display brightness/contrast
- Higher combiner transmissivity
- Minimum visual obstruction in the central field
- Reduced maintenance requirements as a result of longer CRT life and lower High Voltage Power Supply (HVPS) failure rates.

Figure 16 illustrates the HUD performance comparison between the F-18 HUD and the AIDS/F-18 DHUD. Major advantages of the new diffractive technology provide for:

- Higher combiner transparency (85% light transmission)
- Higher combiner reflectance (80% symbology reflectance)
- Higher symbol brightness for improved visibility.
Stroke symbology as high as 3,000 ft-1
525/875 TV line raster as high as 1,000 ft-1
- Stroke symbology can be displayed, superimposed over 525/875 raster
- Night Sensor compatibility (FLIR/LLTV)
- Larger FOV:
 - TFOV - 30°H x 22°V
 - IFOV - 30°H x 18°V
 - TV FOV - 24°H x 18°V

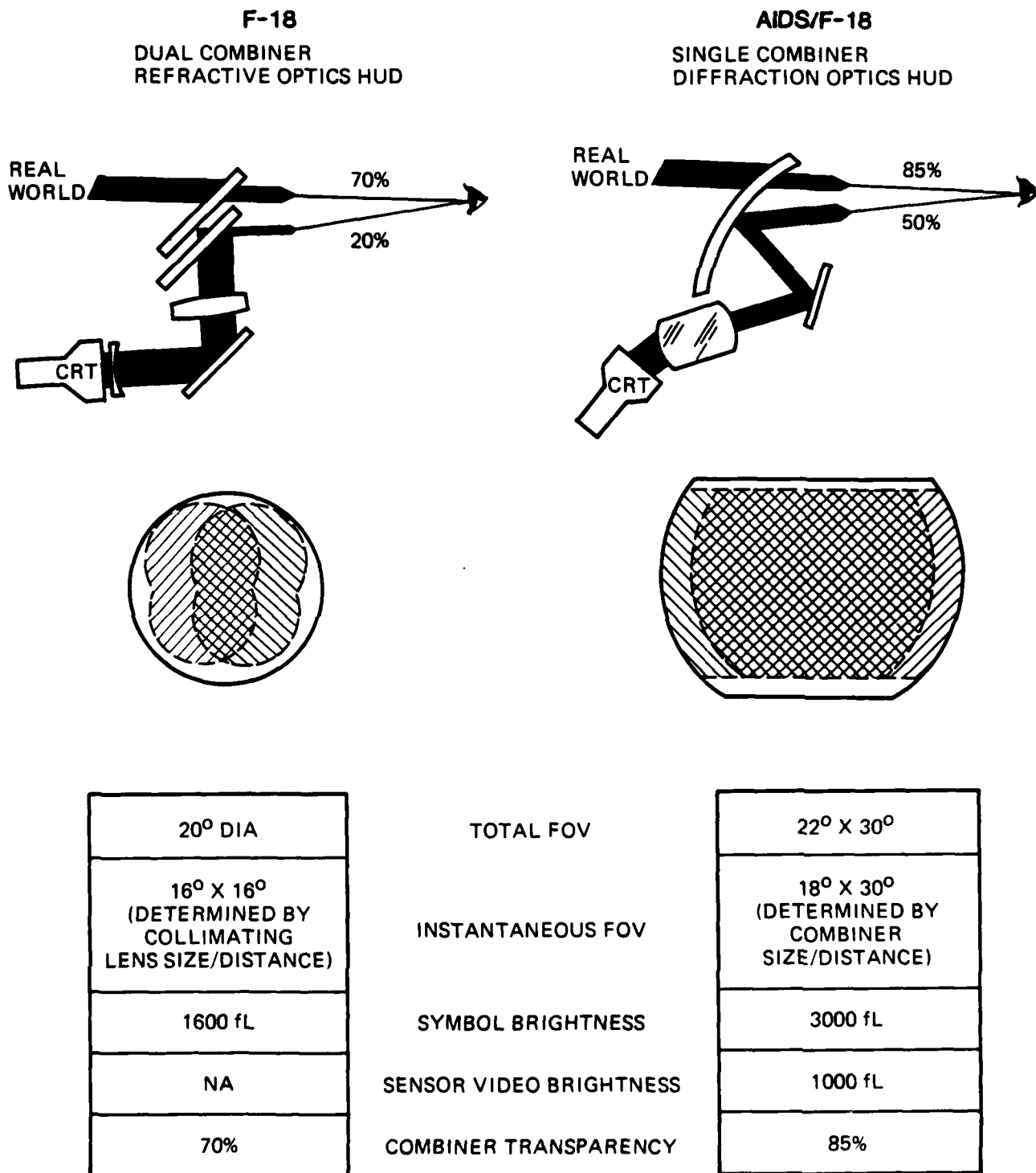

Figure 16. HUD Performance Comparison Between F-18 HUD, and AIDS/F-18 HUD

VII. References

1. P. Seats, "The Cathode-Ray Tube - A Review of Current Technology and Future Trends", IEEE Transactions on Electron Devices, Vol. Ed-18, 9, pp. 679-684, Sept. 1971.
2. "Specification of Hologram Lens System", Naval Air Development Center, Air Vehicle Technology Department, 20 November 1972.
3. Final Technical Report for period 2 April 1973 - 1 April 1974, Contract N66269-73-C-0388, "Holographic Lens for Pilot's Head-Up Display", prepared for Naval Air Development Center, Warminster, PA 18974 by Hughes Research Laboratories, Malibu, CA 90265, D. H. Close, A. Au, and A. Graube, August 1974.
4. Final Technical Report for period 1 July 1974 - 31 October 1974, Contract N62269-74-C-0642, "Holographic Lens for Pilot's Head-Up Display", prepared for Naval Air Development Center, Warminster, PA 18974 by Hughes Research Laboratories, Malibu, CA 90265, D. H. Close, A. Au, and A. Graube, 1 April 1975.
5. Final Technical Report for period 18 March 1975 - 17 September 1975, Contract N62269-75-C-2099, "Holographic Lens for Pilot's Head-Up Display", prepared for Naval Air Development Center, Warminster, PA 18974, by Hughes Research Laboratories, Malibu, CA 92065, A. Au, A. Graube, and L. G. Cook, February 1976.
6. Contract N62269-76-C-0188, Naval Air Development Center, Warminster, PA 18974.
7. D. H. Close, "Holographic Optical Elements", Optical Engineering, 14-408-419, (1975).
8. Final Technical Report for period March 1976 - January 1977, Contract NADC-75320-30, "Trade off Study for a Head-Up Display in New Technologies", W. N. Lewis, R. J. Withrington, D. H. Close, R. S. Jacobs, and R. A. Lohmann.

UNCLASSIFIED

D I S T R I B U T I O N L I S T

REPORT NO. NADC-82147-60

	No. of Copies
COMNAVAIR, AIR-00D4	11
(2 for retention)	
(2 for AIR-604)	
(1 for AIR-340)	
(2 for AIR-340D)	
(2 for AIR-5335)	
(2 for AIR-5313)	
WPAFB, OH (AFWL/MLTE)	3
Hughes Aircraft Co., (Code 60-50), Los Angeles, CA . . .	3
DTIC	12

UNCLASSIFIED