

MICROCOPY RESOLUTION TEST CHART
NBS 1963-A

AD A116154

MRC Technical Summary Report # 2363

THE RIEMANN PROBLEM
IN TWO SPACE DIMENSIONS
FOR A SINGLE CONSERVATION LAW

David H. Wagner

Mathematics Research Center
University of Wisconsin-Madison
610 Walnut Street
Madison, Wisconsin 53706

April 1982

(Received February 12, 1982)

Approved for public release
Distribution unlimited

Sponsored by

U. S. Army Research Office
P. O. Box 12211
Research Triangle Park
North Carolina 27709

DTIC
SELECTE
JUN 29 1982

A

82 06 28 149

DTIC FILE COPY

UNIVERSITY OF WISCONSIN - MADISON
MATHEMATICS RESEARCH CENTER

THE RIEMANN PROBLEM IN TWO SPACE DIMENSIONS
FOR A SINGLE CONSERVATION LAW

David H. Wagner *

Technical Summary Report #2363

April 1982

ABSTRACT

Solutions are given for the partial differential equation

$$\frac{\partial}{\partial t} u(t, x, y) + \frac{\partial}{\partial x} f(u(t, x, y)) + \frac{\partial}{\partial y} g(u(t, x, y)) = 0 ,$$

with initial data constant in each quadrant of the (x, y) plane. This problem generalizes the Riemann Problem for equations in one space dimension. Although existence and uniqueness of solution are known, little is known concerning the qualitative behavior of solutions.

When f and g are convex and $f \equiv g$, then our solutions satisfy the uniqueness, or entropy condition given by Kruzkov and Vol'pert. Under certain extra conditions on f and g , our solutions satisfy the entropy condition if f and g are convex and sufficiently close. A counterexample is given to show the necessity of these extra conditions on f and g . The correct entropy solution for this counter-example exhibits new and interesting phenomena.

AMS (MOS) Subject Classifications: 35C05, 35L60, 35L65, 35L67, 76L05, 76S05

Key Words: Conservation laws, shock waves, two space dimensions.

Work Unit Number 1 - Applied Analysis

* Department of Mathematics, University of Houston, Houston, TX 77004

Accession For
REFS ST-21
101 038
U
DTIC
COPY
INSPECTED
2

AA

SIGNIFICANCE AND EXPLANATION

In making numerical computations of multi-dimensional gas-dynamic flows involving shock waves, a major difficulty arises when two shock waves cross each other. We have made a modest beginning on problems of this type, in the case of a small class of single conservation laws, by giving exact, explicit solutions of two dimensional Riemann Problems. Our initial data consist of step functions constant in the quadrants of the (x,y) plane. However, our results apply to any two intersecting lines of discontinuity.

Our results may also be potentially applicable to the study of oil recovery problems, with regard to "fingering" phenomena.

The responsibility for the wording and views expressed in this descriptive summary lies with MRC, and not with the author of this report.

THE RIEMANN PROBLEM IN TWO SPACE DIMENSIONS
FOR A SINGLE CONSERVATION LAW

David H. Wagner*

1. Introduction.

Let f and g be given real functions satisfying $f'' > 0$ and $g'' > 0$.

Consider the initial value problem

$$\frac{\partial}{\partial t} u(t,x,y) + \frac{\partial}{\partial x} f(u(t,x,y)) + \frac{\partial}{\partial y} g(u(t,x,y)) = 0, \quad (1.1)$$

$$\begin{aligned} u(0,x,y) &= u_1 \text{ for } x > 0, y > 0, \\ &= u_2 \text{ for } x < 0, y > 0, \\ &= u_3 \text{ for } x < 0, y < 0, \\ &= u_4 \text{ for } x > 0, y < 0. \end{aligned} \quad (1.2)$$

This is a Riemann Problem in two space variables. It generalizes the Riemann Problem in one space variable, the study of which has been a key to the understanding of solutions to systems of nonlinear hyperbolic conservation laws in one space variable [2].

Global existence of weak solutions to (1.1) with more general initial data than (1.2) was first proved by Conway and Smoller [1]. Later Vol'pert [9], and Kruzkov [6] proved existence and uniqueness of weak solutions satisfying an entropy condition, in the class of bounded measurable functions.

No similar advances have been made concerning systems of nonlinear hyperbolic conservation laws in two or more space variables; it may be that study of the Riemann Problem for these systems will yield a breakthrough. In this paper we begin an attack on this problem by finding explicit entropy solutions to (1.1), (1.2) for a large class of pairs (f,g) , in the case of a scalar conservation law.

We should mention that Guckenheimer [5], and Val'ka [8], have

*Department of Mathematics, University of Houston, Houston, TX 77004

studied examples of (1.1) with piecewise constant initial data, in configurations different from (1.2).

Definition 1.1. A bounded, measurable function $u: \mathbb{R}^+ \times \mathbb{R}^2 \rightarrow \mathbb{R}$ is said to be a weak solution to the initial value problem consisting of (1.1) with initial data $u(0, x, y) = u_0(x, y)$ if

$$\int_{\mathbb{R}^+} \int_{\mathbb{R}^2} u \frac{\partial}{\partial t} \phi + f(u) \frac{\partial}{\partial x} \phi + g(u) \frac{\partial}{\partial y} \phi \, dx \, dy \, dt = 0, \quad (1.3)$$

for every test function $\phi \in C_0^\infty(\mathbb{R}^+ \times \mathbb{R}^2)$, and if $u(t, \cdot, \cdot) \rightarrow u_0$ in L_{loc}^1 as $t \rightarrow 0$.

Definition 1.2. (Vol'pert [8], Kruzkov [6]). A weak solution u , to (1.1), is said to satisfy the entropy condition if for any real constant k and any $\phi \in C_0^\infty(\mathbb{R}^+ \times \mathbb{R}^2)$ such that $\phi \geq 0$,

$$\begin{aligned} \int_{\mathbb{R}^+} \int_{\mathbb{R}^2} \text{sign}(u-k) \left[(u-k) \frac{\partial}{\partial t} \phi + (f(u) - f(k)) \frac{\partial}{\partial x} \phi \right. \\ \left. + (g(u) - g(k)) \frac{\partial}{\partial y} \phi \right] \, dx \, dy \, dt \geq 0. \end{aligned} \quad (1.4)$$

We shall construct weak solutions to (1.1), (1.2) which are valid for any choice of the constants u_1, u_2, u_3 , and u_4 . It is conceivable that this construction may fail to produce a well defined function if f and g are not sufficiently close to each other. The degree of closeness that is sufficient may depend on the choice of f and g ; therefore, in order to be rigorous we will state and prove our theorems in terms of the distance from f and g to a given reference function h . Thus we consider the pair (f, g) as a perturbation from the pair (h, h) . Of course, our theorems will cover the case where f is held fixed and g is perturbed away from f .

The form of our solution to (1.1), (1.2) varies with different orderings of the constants u_i . Thus there are twenty-four cases to be considered. Fortunately, these twenty-four cases can be reduced, via geometrical reflections and inversions, to eight. We will however, consider each of the twenty-four cases and identify the reductions.

We shall show that our construction produces a well defined function which satisfies the entropy condition, if $f \equiv g$, and $f'' > 0$; see Theorem 1. We will also show, in Theorem 2, that under certain ordering conditions on u_1, u_2, u_3 , and u_4 , we have that for every function h such that $h'' > 0$, there exists $\epsilon > 0$ such that $\|f - h\|_{C^2} < \epsilon$ and $\|g - h\|_{C^2} < \epsilon$ imply that our construction produces a well defined function which satisfies the entropy condition. In Theorem 3 we shall show that if the ordering conditions of Theorem 2 are not satisfied, then, provided $f'' = g''$ and $f''' = g'''$ at certain points w to be specified later, for every h such that $h'' > 0$, and $h'' = f''$ and $h''' = f'''$ at all of the points w , there exists $\epsilon > 0$ such that $\|f - h\|_{C^4} < \epsilon$ and $\|g - h\|_{C^4} < \epsilon$ imply that our construction produces a well defined function which satisfies the entropy condition.

Finally, an example will be given where $f''' \neq g'''$ at the point w of Theorem 3, and where our constructed solution, although it is a function, does not satisfy the entropy condition. In this example f and g may be arbitrarily close, and the initial data may be arbitrarily small. We will also give the correct entropy solution for this example.

One system of equations containing a scalar conservation law is that describing two phase, two dimensional immiscible flow in porous media,

where gravity, capillary pressure, molecular diffusion, compressibility, as well as spatial variations in porosity, depth, and viscosity have been neglected (see [3,4,7]):

$$\frac{\partial S}{\partial t} + \frac{\partial}{\partial x} (v_1 f(S)) + \frac{\partial}{\partial y} (v_2 f(S)) = 0 \quad (1.5)$$

$$\vec{v} = (v_1, v_2) = -k(S)\nabla p \quad (1.6)$$

$$\vec{V} \cdot \vec{v} = \text{source terms} . \quad (1.7)$$

In [3,4], $f(S) = s^2/k(S)$ was used. Although one may imagine that our solutions are thus special entropy solutions of this system with ∇p constant, (1.7) prevents this. However some of our solutions, Cases 9 and 19, exhibit shock waves meeting at an acute angle, or in a cusp, similar to the fingering behavior which is of interest in oil recovery problems, and for which (1.5 - 1.7) is a model.

2. Construction of the Solutions.

We shall see that our constructed solutions are piecewise smooth, having discontinuity sets consisting almost everywhere with respect to two dimensional Hausdorff measure, of smooth surfaces. In this context, Definition 1.2 implies two conditions, given below, on the discontinuities of a solution. These can easily be derived via localization and integration by parts, and appropriate choices of the constant k .

Condition 2.1. (The Rankine-Hugoniot condition). At any point p on a surface of discontinuity S of the solution u , if

(a) \vec{n} is a unit normal vector to S at p ,

(b) $u^+ = \lim_{\epsilon \rightarrow 0^+} u(p + \epsilon\vec{n})$,

(c) $u^- = \lim_{\epsilon \rightarrow 0^+} u(p - \epsilon\vec{n})$,

then

$$\vec{n} \cdot (u^+ - u^-, f(u^+) - f(u^-), g(u^+) - g(u^-)) = 0. \quad (2.1)$$

Condition 2.2. (The entropy condition). Orient \vec{n} so that $u^+ \geq u^-$.

If k is any constant such that $u^- \leq k \leq u^+$, then

$$\vec{n} \cdot (k - u^+, f(k) - f(u^+), g(k) - g(u^+)) \geq 0. \quad (2.2)$$

Using (2.1) one may check that (2.2) is equivalent to

$$\vec{n} \cdot (k - u^-, f(k) - f(u^-), g(k) - g(u^-)) \geq 0. \quad (2.3)$$

One may further check that if a function u is a piecewise classical solution, except for smooth surfaces of discontinuity where Conditions 2.1 and 2.2 hold, then u is a weak solution satisfying the entropy condition.

Let us consider one dimensional shock waves and rarefaction waves, as they arise in the two dimensional Riemann Problem.

(a) The one dimensional shock wave. If the initial data is

$$\begin{aligned} u(0, x, y) &= u_1 \text{ if } x < 0, \\ &= u_2 \text{ if } x > 0, \end{aligned} \quad (2.4)$$

and $u_1 > u_2$ then the problem really has only one space dimension:

$$\begin{aligned} u_t + f(u)_x &= 0, \\ u(0, x) &= u_1 \text{ if } x < 0, \\ &= u_2 \text{ if } x > 0. \end{aligned} \quad (2.5)$$

In this case the solution is well known:

$$\begin{aligned} u(t, x, y) = u(t, x) &= u_1 \text{ if } x \leq \frac{f(u_1) - f(u_2)}{u_1 - u_2} t, \\ &= u_2 \text{ if } x \geq \frac{f(u_1) - f(u_2)}{u_1 - u_2} t. \end{aligned} \quad (2.6)$$

This solution has a discontinuity, called a "shock wave," along the plane

$$x = \frac{f(u_1) - f(u_2)}{u_1 - u_2} t. \quad (2.7)$$

We will refer to this shock wave as "SX[u_1, u_2]," for "shock in the x direction connecting u_1 to u_2 ." The shock wave in the y direction obtained by interchanging x with y and f with g above we will call "SY[u_1, u_2]."

(b) The one dimensional rarefaction wave. If the initial data is:

$$\begin{aligned} u(0, x, y) &= u_1, \text{ if } x < 0, \\ &= u_2, \text{ if } x > 0, \end{aligned} \quad (2.8)$$

and $u_1 < u_2$, then the problem again reduces to (2.5), and its solution is well known:

$$\begin{aligned} u(t, x, y) = u(t, x) &= u_1 \text{ if } x < f'(u_1)t, \\ &= u_2 \text{ if } x > f'(u_2)t, \\ &= s \text{ if } x = g'(s)t, \quad u_1 \leq s \leq u_2. \end{aligned} \quad (2.9)$$

The part of this solution between $x = f'(u_1)t$ and $x = f'(u_2)t$ is called a "rarefaction wave." We will refer to this particular rarefaction wave as RX[u_1, u_2], for "rarefaction in the x-direction, connecting u_1 to u_2 ."

Note that the solution described in (a) is a weak solution to (b), since it satisfies Condition (2.1). However it does not satisfy the entropy condition since $u_1 < u_2$, and f is assumed to be convex.

The interaction of RX with SY. Let the initial data be as in (1.2), with $u_1 = u_2 = u_3 = w$, and $u_4 = v$, and $v > w$. Then for bounded t, and sufficiently large x, the solution looks locally like SY[v, w],

due to the principle of finite domain of dependence, which was shown to hold in this context by Vol'pert [9], and Kruzkov [6]. For y sufficiently negative, the solution looks locally like $RX[w,v]$. Since a solution is invariant under dilations $(t,x,y) \rightarrow (ct,cx,cy)$ for $c > 0$ whenever the initial data $u(0,x,y)$ is invariant under dilations $(x,y) \rightarrow (cx,cy)$, we may describe a solution completely by describing it along the plane $t = 1$. The solution is constant on rays through the (t,x,y) origin.

Thus our current knowledge of the solution to this problem may be described by Figure 1. In Figure 1, the horizontal line

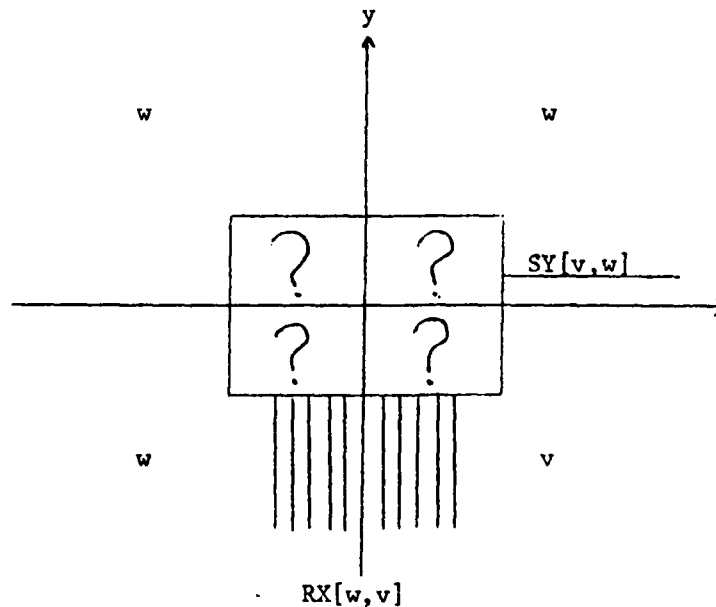

Figure 1. Interaction of RX with SY

labelled "SY[v,w]" indicates the plane of that shock wave, and the vertical lines labelled $RX[w,v]$ indicate planes along which the solution u is constant, thereby depicting a rarefaction wave. The space labelled "?" is filled in as follows. The RX region meets the region where $u = w$ along a

smooth surface of discontinuity S , having equations $x = f'(s)t$, $y = \gamma(s)t$, parameterized by s , t for $w \leq s \leq v$. The unknown function γ is determined by the jump conditions, as follows.

First we describe the normal vector $\vec{n} = (n_t, n_x, n_y)$, to the shock surface S in terms of f and γ . To do this, we need two tangent vectors to the surface $x = f'(s)t$, $y = \gamma(s)t$.

Holding s fixed, we have $dx = f'(s)dt$, $dy = \gamma(s)dt$. Holding t fixed, we have $dx = f''(s)t ds$, $dy = \gamma'(s)t ds$. Thus we have two tangent vectors, $\vec{v}_1 = (1, f'(s), \gamma(s))$, $\vec{v}_2 = (0, f''(s), \gamma'(s))$. Then

$$\vec{n} = \vec{v}_1 \times \vec{v}_2 = (-f''(s)\gamma(s) + f'(s)\gamma'(s), -\gamma'(s), f''(s)). \quad (2.10)$$

Keeping in mind that in $RX[w, v]$, $u = s$ on the plane $x = f'(s)t$ for $y < \gamma(s)t$, the Rankine-Hugoniot condition gives us:

$$(w - s)(f'(s)\gamma'(s) - f''(s)\gamma(s)) + (f(w) - f(s))(-\gamma'(s)) + f''(s)(g(w) - g(s)) = 0. \quad (2.11)$$

This equation is a first order, linear, scalar differential equation for the unknown function γ :

$$\gamma'(s) = f''(s) \frac{g(w) - g(s) - \gamma(s)(w - s)}{f(w) - f(s) - f'(s)(w - s)}. \quad (2.12)$$

Note that the denominator in the right hand side of (2.12) is always positive for $w \neq s$, since $f'' > 0$.

The shock surface S should be a smooth continuation of the planar shock wave $SY[v, w]$ through the rarefaction wave $RX[w, v]$. Therefore these two surfaces should meet along a common line at the right edge of $RX[w, v]$. This yields the following initial condition for γ :

$$\gamma(v) = \frac{g(v) - g(w)}{v - w} . \quad (2.13)$$

Since (2.12) is linear, it is thus explicitly solvable. The following formula for γ can be obtained from the usual one by an integration by parts:

$$\begin{aligned} \gamma(s) = & \frac{g(s) - g(w)}{s - w} \quad (2.14) \\ & - \int_v^s \exp \left(\int_s^r \frac{f''(z)(w - z)}{f(w) - f(z) - f'(z)(w - z)} dz \right) \\ & \cdot \frac{g(w) - g(r) - g'(r)(w - r)}{(w - r)^2} dr . \end{aligned}$$

Note that for $w < s < v$, we have $\gamma(s) > \frac{g(s) - g(w)}{s - w}$; hence, using (2.12), we have $\gamma'(s) > 0$. Therefore, as s decreases to w , $\gamma(s)$ approaches some finite limit, which is greater than or equal to $g'(w)$. In fact this limit is $g'(w)$, as we shall see in §3.

We shall refer to the shock surface S as " $\Gamma[v,w]$." See Figure 2. This shock surface will occur in solutions to the Riemann Problem, and usually in truncated form, denoted here $\Gamma[v,w;p]$, namely the portion of $\Gamma[v,w]$ corresponding to values of s greater than some number p and less than v . Reflecting $\Gamma[v,w]$ across the line $x = y$ by interchanging x with y and f with g , we obtain a similar shock wave, denoted " $\Gamma R[v,w]$."

Note that, given any solution u to (1.1), with initial data $u_0(x,y)$, the function \tilde{u} given by $\tilde{u}(t,x,y) = -u(t,-x,-y)$ is a solution to

$$\tilde{u}_t + f(-\tilde{u})_x + g(-\tilde{u})_y = 0$$

with initial data $\tilde{u}(0,x,y) = -u_0(-x,-y)$. Thus, if $u(t,x,y) = F(t,x,y,f,g,u_1,u_2,u_3,u_4)$ is a formula giving the solution to the Riemann

Problem in terms of f , g , and the initial data constants u_1, \dots, u_4 for a given ordering of these constants, then the solution for the case given by interchanging u_1 with u_3 and u_2 with u_4 in the given ordering, and then reversing the order, is $u(t, x, y) = -F(t, -x, -y, \overset{v}{f}, \overset{v}{g}, -u_3, -u_4, -u_1, -u_2)$, where $\overset{v}{f}(s) = f(-s)$. Thus, for example, the solution for the case $u_1 < u_2 < u_3 < u_4$ determines the solution for the case $u_3 > u_4 > u_1 > u_2$. We call this procedure "inversion."

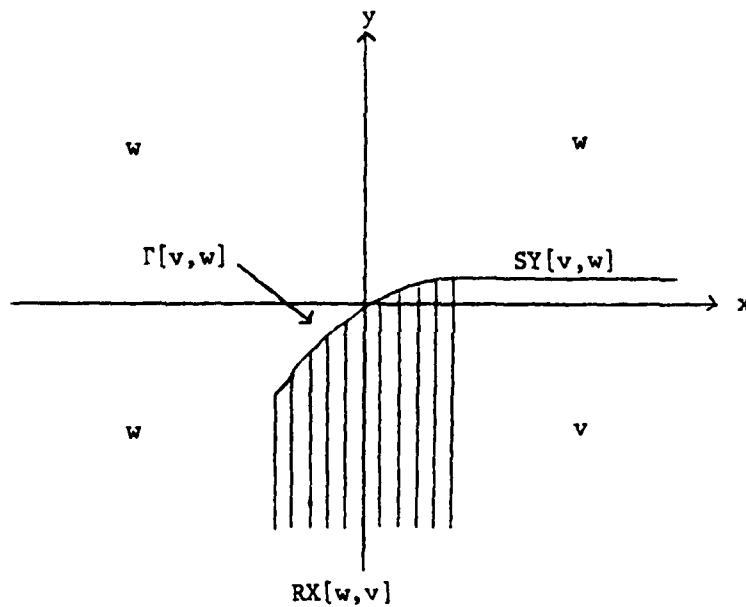

Figure 2. The Shock Surface $\Gamma[v,w]$

If we apply the inversion process to $\Gamma[v,w]$, we get an inverted Γ -shock, which we shall call " $\Gamma I[v,w]$." See Figure 3. We call the reflection of $\Gamma I[v,w]$ across the line $y = x$, " $\Gamma IR[v,w]$."

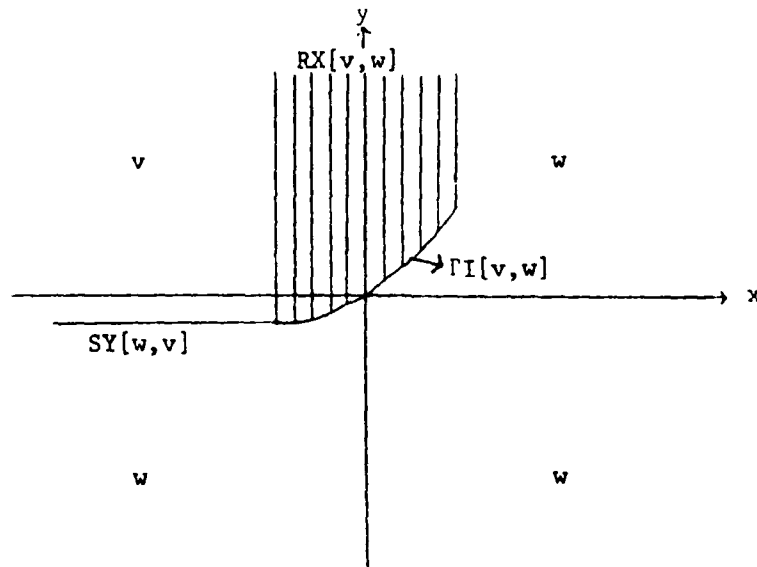

Figure 3. The Shock Surface $\Gamma I[v,w]$

We are now ready to discuss the Riemann Problem.

The formula for the solution to the Riemann Problem is different for different orderings of the initial data constants u_1 , u_2 , u_3 , and u_4 . This indicates that twenty-four cases must be considered; however reflections, inversions, and reflected inversions of cases previously discussed will only be indicated as such, and will not be discussed in detail. This reduces the number of cases to be discussed, to eight. The formula to be given consists of a picture for each case, with labels such as $RX[u_1, u_2]$, $SY[u_2, u_3]$, and $\Gamma[u_1, u_2]$ given to parts of the picture. The interested reader may then refer to the formula given earlier in this chapter for each of these phenomena.

Case 1. $u_1 < u_2 < u_3 < u_4$. At $t = 1$ the solution looks like Figure 4.

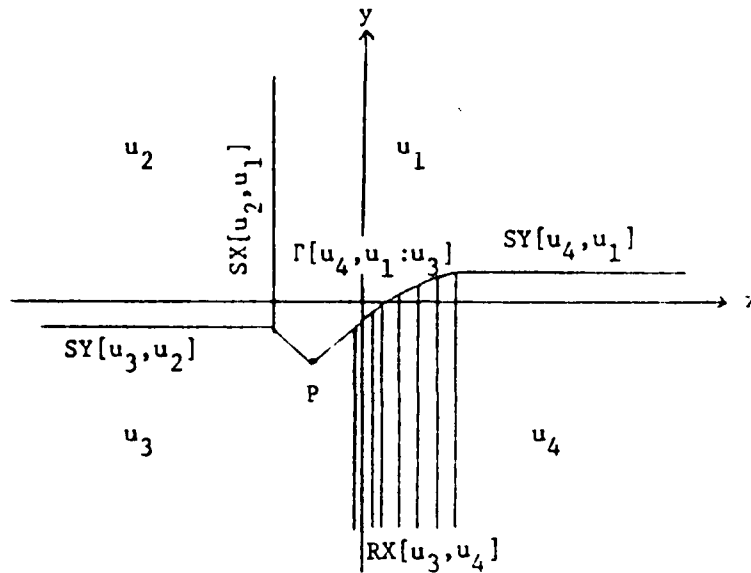

Figure 4. The Case $u_1 < u_2 < u_3 < u_4$

In this case we have two shock waves extending from the intersection of $SY[u_3, u_4]$ and $SX[u_2, u_1]$ to the point P , and from the line $x = f'(u_3)t$, $y = \gamma(u_3)t$ to P . The following theorem concerning these shock waves is due to Guckenheimer [5].

Theorem. A shock surface between two constant states a, b , in a solution to the Riemann Problem lies in a plane which passes through the line

$$x = \frac{f(a) - f(b)}{a - b} t, \quad y = \frac{g(a) - g(b)}{a - b} t. \quad (2.15)$$

Thus the two shock waves extending to P are planar. We shall call these shock waves " Ψ -shocks."

Now from (2.15) we deduce that P has coordinates

$$\left(\frac{f(u_3) - f(u_1)}{u_3 - u_1}, \frac{g(u_3) - g(u_1)}{u_3 - u_1} \right).$$

Note that since $u_1 < u_2 < u_3$, we have

$$\frac{f(u_2) - f(u_1)}{u_2 - u_1} < \frac{f(u_3) - f(u_1)}{u_3 - u_1} < f'(u_3); \quad (2.16)$$

these are the x-coordinates of $SX[u_2, u_1]$, P, and the left edge of $RX[u_3, u_4]$, respectively. Thus both Ψ -shocks may be parameterized by s and t with the equations $x = f'(s)t$ and $y = \psi(s)t$. In case $u_1 = u_2$ or $u_2 = u_3$ then either the left or right Ψ -shock, respectively, is not present, because both end points of that particular shock are identical.

Using the method by which (2.12) was derived, one may derive the following differential equation for ψ :

$$\psi'(s) = f''(s) \frac{g(u_1) - g(u_3) - \psi(s)(u_1 - u_3)}{f(u_1) - f(u_3) - f'(s)(u_1 - u_3)}. \quad (2.17)$$

Note, from Figure 4, that the right Ψ -shock meets the left endpoint of the $\Gamma[u_4, u_1: u_3]$ shock wave continuously, so that $\psi(u_3) = \gamma(u_3)$. Comparing (2.17) with (2.12), we see that $\psi'(u_3) = \gamma'(u_3)$. Thus the Γ -shock meets the Ψ -shock with first-order smoothness. We may also deduce that for any point $(f'(v), \gamma(v))$ on the $\Gamma[u_4, u_1]$ shock at $t = 1$, the tangent line to the curve $x = f'(s)$, $y = \gamma(s)$ passes through the point P given by

$$P = \left(\frac{f(v) - f(u_1)}{v - u_1}, \frac{g(v) - g(u_1)}{v - u_1} \right). \quad (2.18)$$

One may also deduce this by rewriting (2.12):

$$\frac{dy}{dx} = \frac{\gamma'(s)}{f''(s)} = \frac{\frac{g(u_1) - g(s)}{u_1 - s} - \gamma(s)}{\frac{f(u_1) - f(s)}{u_1 - s} - f'(s)}. \quad (2.19)$$

Case 2. $u_1 < u_4 < u_3 < u_2$. This is the reflection across the line $y = x$ of Case 1.

Case 3. $u_3 > u_4 > u_1 > u_2$. This is the inversion of Case 1.

Case 4. $u_3 > u_2 > u_1 > u_4$. This is the reflected inversion of Case 1.

Case 5. $u_2 < u_1 < u_3 < u_4$. At $t = 1$ the solution looks like Figure 5.

Note that the right edge of $RX[u_2, u_1]$ has equation $x = f'(u_1)t$. Since $f'' > 0$ and $u_1 < u_3$, $f'(u_1) < f'(u_3)$; furthermore, $x = f'(u_3)t$ is the equation for the left edge of $RX[u_3, u_4]$. Thus $RX[u_2, u_1]$ lies completely to the left of $RX[u_3, u_4]$ in this case.

The point P has the same coordinates as in Case 1.

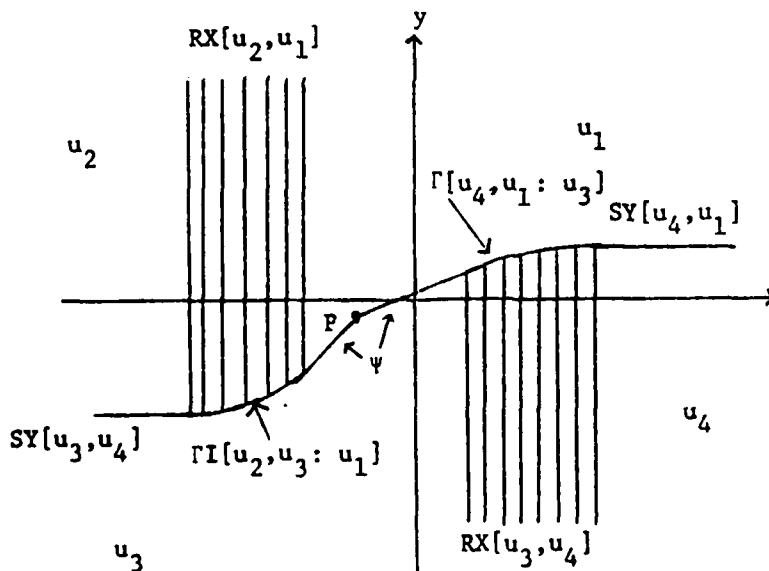

Figure 5, The case $u_2 < u_1 < u_3 < u_4$

Case 6. $u_4 < u_1 < u_3 < u_2$. This is the reflection of Case 5. Note that Cases 5 and 6 are invariant under inversion.

Case 7. $u_2 < u_3 < u_1 < u_4$. At $t = 1$ the solution looks like Figure 6.

In this case, since $u_3 < u_1$, and $f'' > 0$, we have that $f'(u_3) < f'(u_1)$; hence $RX[u_2, u_1]$ overlaps $RY[u_3, u_4]$. Also the shock waves $\Gamma[u_4, u_1]$ and $\Gamma I[u_2, u_3]$ are not truncated in this case. The point Q_1 has coordinates $(f'(u_1), g'(u_1))$, and $Q_2 = (f'(u_3), g'(u_3))$.

Case 8. $u_4 < u_3 < u_1 < u_2$. This is the reflection of Case 7. Note that Cases 7 and 8 are invariant under inversion.

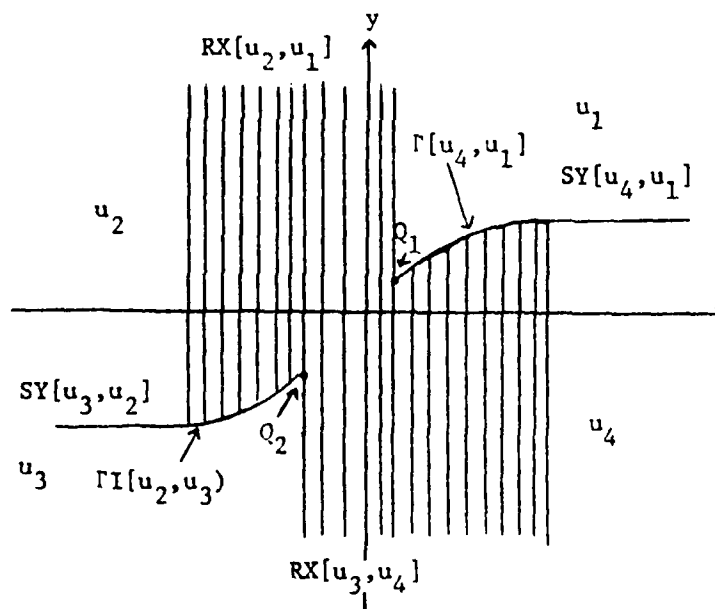

Figure 6. The case $u_2 < u_3 < u_1 < u_4$

Case 9. $u_1 < u_3 < u_2 < u_4$. At $t = 1$ the solution looks like Figure 7.

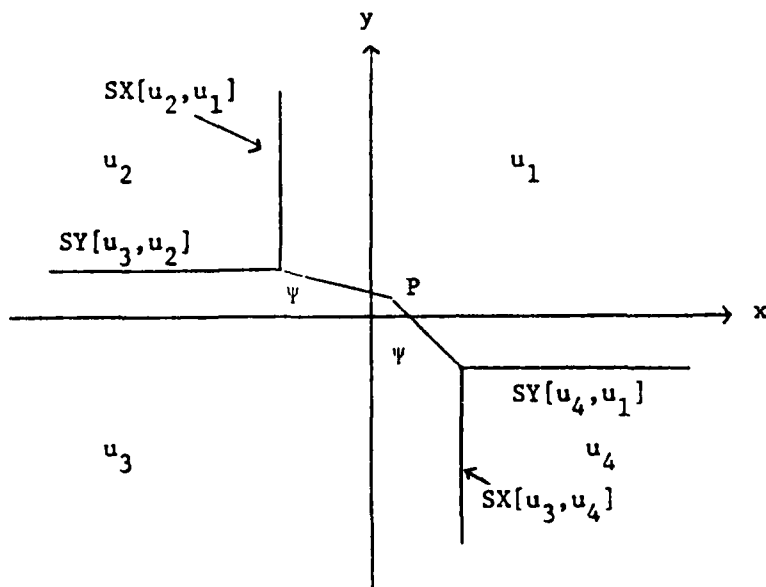

Figure 8. The case $u_1 < u_2 < u_4 < u_3$

Case 15. $u_2 < u_3 < u_4 < u_1$. At $t = 1$ the solution looks like Figure 9. Here Q has coordinates $(f'(u_3), g'(u_3))$. Between the points $C_1(f'(u_4), g'(u_4))$ and $C_2 = (f'(u_1), g'(u_1))$, the rarefaction waves $RX[u_4, u_1]$ and $RY[u_4, u_1]$ meet along the surface Δ , which may be described by the equations $x = f'(s)t$ and $y = g'(s)t$, for $u_4 < s < u_1$ and $t > 0$. The plane sections where $u = s$ in each wave meet along the line $x = f'(s)t$, $y = g'(s)t$. Thus the solution is continuous, though not differentiable, along this surface. One may check that the entropy condition is satisfied near Δ .

Case 16. $u_4 < u_3 < u_2 < u_1$. This is the reflection of Case 15.

Case 17. $u_4 > u_1 > u_2 > u_3$. This is the inversion of Case 15.

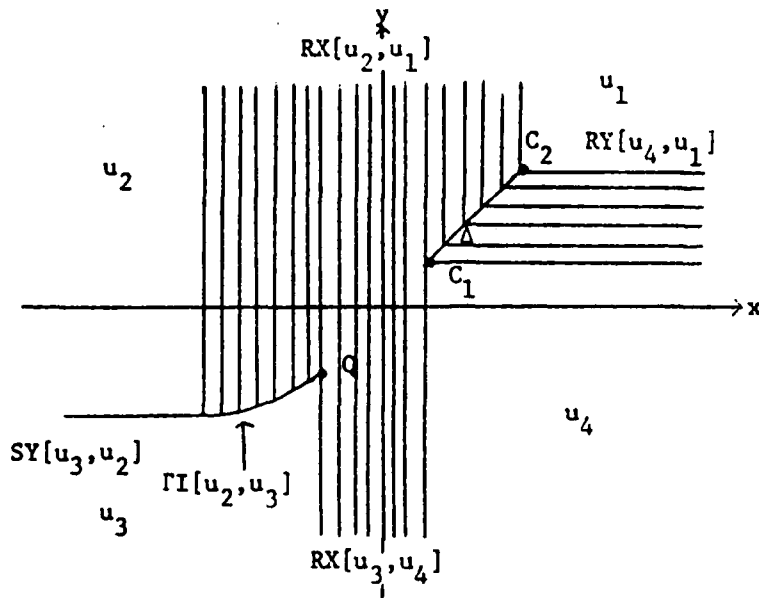

Figure 9. The case $u_2 < u_3 < u_4 < u_1$

Case 18. $u_2 > u_1 > u_4 > u_3$. This is the reflected inversion of Case 15.

Case 19. $u_2 < u_4 < u_3 < u_1$. At $t = 1$ the solution looks like Figure 10.

Case 20. $u_4 < u_2 < u_3 < u_1$. This is the reflection of Case 19.

Case 21. $u_4 > u_2 > u_1 > u_3$. This is the inversion of Case 19.

Case 22. $u_2 > u_4 > u_1 > u_3$. This is the reflection inversion of Case 19.

Case 23. $u_3 < u_2 < u_4 < u_1$. At $t = 1$ the solution looks like Figure 11.

Here Q_1 has coordinates $(f'(u_3), g'(u_3))$. Also $Q_2 = (f'(u_2), g'(u_2))$,

$Q_3 = (f'(u_4), g'(u_4))$, $Q_4 = (f'(u_1), g'(u_1))$.

Case 24. $u_3 < u_4 < u_2 < u_1$. This is the reflection of Case 23. Note that Case 23 and 24 are invariant under inversion. Also note that Cases 23 and 24 are the only cases with continuous solutions.

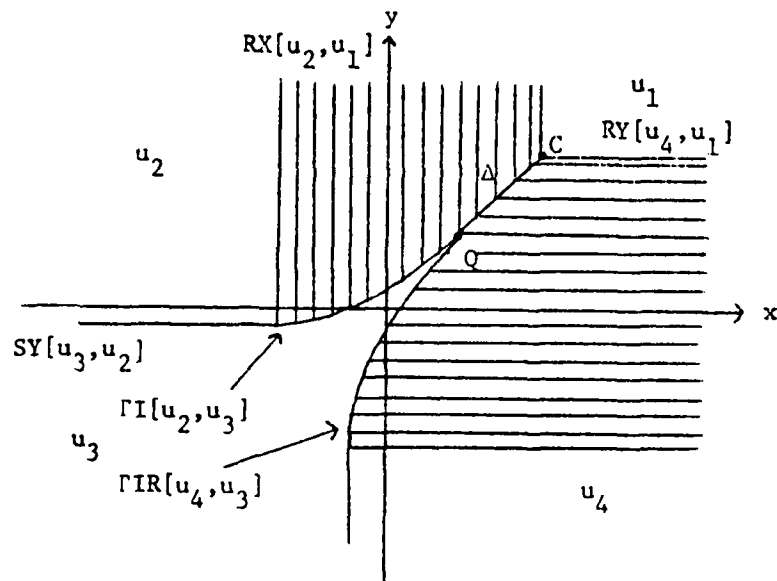

Figure 10. The case $u_2 < u_4 < u_3 < u_1$

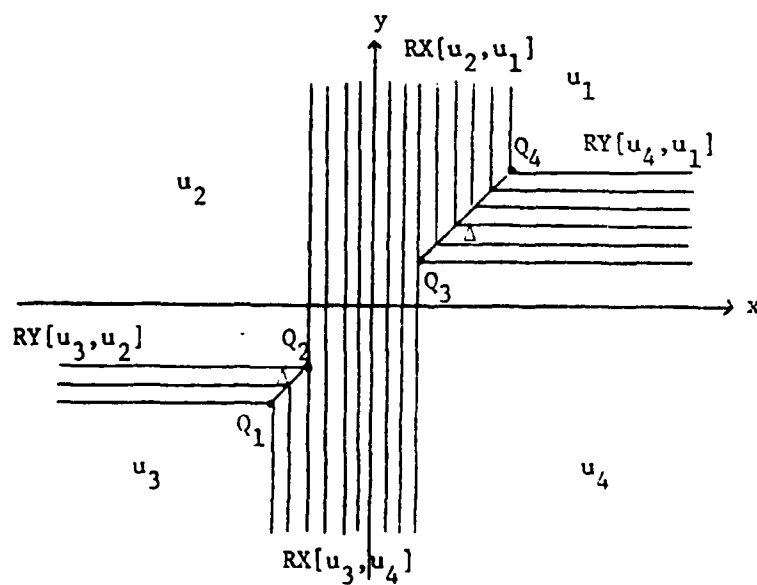

Figure 11. The case $u_3 < u_2 < u_4 < u_1$

3. Verification of the entropy condition.

We will now prove three theorems showing that under certain conditions, our solutions are single valued and satisfy the entropy condition. Theorem 1 treats the case where $f \equiv g$ and is convex. It is easily seen that this also includes the case $f'' = cg''$. Theorems 2 and 3 concern perturbations away from this case.

Theorem 1. If $f \equiv g$, then the constructions in §2 for Cases 1-24 define functions, and these functions satisfy the entropy condition.

Remark. In Cases 9-12 and 19-22 it is conceivable that our solution may fail to be single valued due to overlapping Γ shocks, as illustrated in Figure 12. Therefore it is necessary to prove that this does not occur.

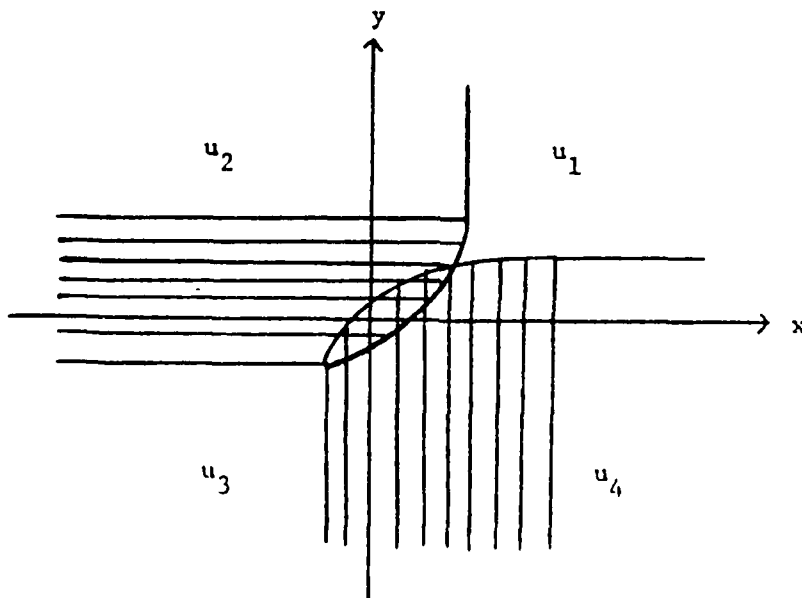

Figure 12. Overlap

Proof. We need to prove that the entropy condition is satisfied for SX, SY, Γ , and Ψ . However SX and SY are one-dimensional shocks and the entropy condition is known to hold for them. The proof for $\Gamma[v, w]$ is as follows: To verify the entropy condition we require \vec{n} , the normal vector to $\Gamma[v, w]$, to be oriented towards the side of the shock surface where u is larger. In this situation this means that \vec{n} must "point in" to the rarefaction wave. Since the rarefaction wave lies in the region $y < \gamma(s)t$, we must have $n_y \leq 0$. Since $f'' > 0$, this means we should choose:

$$\vec{n} = (f''(s)\gamma(s) - f'(s)\gamma'(s), \gamma'(s), -f''(s)). \quad (3.1)$$

Thus, we must verify

$$(k-w)(f''(s)\gamma(s) - f'(s)\gamma'(s)) + (f(k) - f(w))(\gamma'(s) - f''(s)) \geq 0 \quad (3.2)$$

for all $w < k < s < v$

Lemma 1.1 When $f \equiv g$, $\gamma'(s) < f''(s)$ for $s > w$.

Proof. Using (2.13), and using the fact that $f'' > 0$, we have that $\gamma(v) < f'(v)$. Furthermore $\gamma = f'$ is a solution of (2.12). The uniqueness of solutions for $s > w$ implies that $\gamma(s) < f'(s)$ for all $s > w$. Using (2.12) and (2.13), one notes that $\gamma'(v) = 0 < f''(v)$, and also that $\gamma'(s) = f''(s)$ implies $f(w) - f(s) - \gamma(s)(w-s) = f(w) - f(s) - f'(s)(w-s)$; this in turn implies that $f'(s) = \gamma(s)$ when $s \neq w$. Since $\gamma(s) < f'(s)$, we must have that $\gamma'(s) < f''(s)$ for $s > w$.

We now verify (3.2). If the left hand side of (3.2) is considered as a function $F(k)$, then one checks using Lemma 1.1 that $F''(k) > 0$;

also $F(w) = 0$. Furthermore, $F(s) = 0$ since in (3.2) one may replace all w 's by s 's, using (2.1). Therefore $F(k) > 0$ for $w < k < s < v$; this is (3.2).

The entropy condition for reflected and inverted $\Gamma[v, w]$ shock waves may similarly be verified.

It remains to verify the entropy condition for Ψ -shocks. These appear in two different contexts:

(1) Tangential shocks, that is, Ψ shocks which are tangential to Γ shocks. Such a Ψ shock has the same normal vector \hat{n} as does the Γ shock at the point of tangency, and also the same values of u on either side of the shock. Therefore the entropy condition for a tangential Ψ -shock is equivalent to the entropy condition for the corresponding Γ shock at the point of tangency.

(2) Non-tangential shocks. One may check, using the ordering of u_1, u_2, u_3 , and u_4 , and the convexity of f and g , that the intersection of any non-tangential Ψ -shock surface with the plane $t = 1$ is a line segment with negative slope, as depicted in Figures 4 and 8. Furthermore any non-tangential Ψ -shock is a shock between u_3 and u_1 , with $u_3 > u_1$, with the region $u = u_1$ above, and to the right of the shock. Thus $\hat{n} = (n_t, n_x, n_y)$ with n_x and n_y negative. The entropy condition becomes

$$(k - u_3)n_t + (f(k) - f(u_3))(n_x + n_y) \geq 0, \quad (3.3)$$

for $u_3 > k > u_1$. Since $n_x + n_y < 0$, and f is convex, the left side of this inequality has negative second derivative with respect to k , and by (2.1), is zero when $k = u_3$ or $k = u_1$. Hence it is positive for

values of k between u_1 and u_3 .

To verify that our solutions are single valued it suffices to show that overlap of Γ -shocks does not occur. In the proof of Lemma 1.1 we saw that $\gamma(s) < f'(s)$; thus both Γ shocks lie on opposite sides of the curve $x = f'(s)$, $y = f'(s)$.

Theorem 2. Let u_1, u_2, u_3, u_4 be such that our proposed solution to (1.1), (1.2) contains no complete Γ , ΓR , ΓI , or ΓIR shock, that is, let us consider only Cases 1-6, 9-14, 23, and 24 of §2. Let

$M = \max_{1 \leq i \leq 4} u_i$, and $m = \min_{1 \leq i \leq 4} u_i$. Then for any given function h such that

$h'' > 0$, there exists $\epsilon > 0$ such that whenever $\|f - h\|_{C^2[m, M]} < \epsilon$, and

$\|g - h\|_{C^2[m, M]} < \epsilon$, our construction for the solution to (1.1), (1.2) in

these cases defines a function, and this function satisfies the entropy condition.

Proof. As noted before, it suffices to prove that in our solution to the perturbed equation, the entropy condition holds for truncated Γ -shocks, and for non-tangential Ψ -shocks.

Recall that the entropy condition states that for $\Gamma[v, w: p]$ we must have:

$$(k - w)n_t + (f(k) - f(w))n_x + (g(k) - g(w))n_y \geq 0, \quad (3.4)$$

or

$$W(k, s) = (f''(s)\gamma(s) - f'(s)\gamma'(s))(k - w) \quad (3.5)$$

$$+ \gamma'(s)(f(k) - f(w)) - f''(s)(g(k) - g(w)) \geq 0,$$

for all $w \leq k \leq s \leq v$, and $w < p < s$. The function γ satisfies the initial value problem (2.12), (2.13). Since f is convex (for ϵ sufficiently small), and $s \geq p > w$, the denominators in (2.14), the formula for γ , are bounded away from zero, and the bound depends only on h, ϵ, v, w , and p . Thus we may conclude that the map $(f, g) \rightarrow \gamma$ is continuous from $\{f | f \in C^2[p, v], f'' > 0\} \times \{g | g \in C^2[p, v], g'' > 0\}$ to $C^1[p, v]$.

Next note that

$$\frac{\partial^2 W}{\partial k^2} = \gamma'(s)f''(k) - f''(s)g''(k), \quad (3.6)$$

and note that $W(s, s) = W(w, s) = 0$, by (2.1). When $f \equiv g \equiv h$ we know by Lemma 1.1 that $\gamma'(s) < f''(s)$ for $p < s < v$. Thus $\frac{\partial^2 W}{\partial k^2} < 0$ for $w \leq k \leq s \leq v$, $w < p < s$, when $f \equiv g \equiv h$. Moreover $\frac{\partial^2 W}{\partial k^2}$ depends continuously on f and g in the C^2 topology on f and g . Therefore there exists $\epsilon > 0$ such that $\|f - h\|_{C^2} < \epsilon$ and $\|g - h\|_{C^2} < \epsilon$ imply $\frac{\partial^2 W}{\partial k^2} > 0$, and it follows that $\Gamma[v, w; p]$ satisfies the entropy condition.

Since $\gamma(s) < f'(s)$ when $f \equiv g \equiv h$, for ϵ sufficiently small we must have $\gamma(s) < g'(s)$, thus in Case 9-12 the two Γ -shocks lie on opposite sides of the surface $x = f'(s)t, y = g'(s)t$. Thus overlap does not occur for ϵ sufficiently small.

Finally, for non-tangential Ψ -shocks we must show:

$$(k - u_3)n_t + (f(k) - f(u_3))n_x + (g(k) - g(u_3))n_y \geq 0 \quad (3.7)$$

for $u_1 \leq k \leq u_3$. Since $n_x < 0$ and $n_y < 0$ as we saw in the previous section, and since $f'' > 0$ and $g'' > 0$ for ϵ sufficiently small, the left hand side of (3.7) has negative second derivative with respect to k , and equals

zero when $k = u_1$ or $k = u_3$. Thus (3.7) holds for values of k between u_1 and u_3 .

Theorem 3. Suppose $u_1, u_2, u_3,$ and u_4 are such that our proposed formula for the solution to (1.1), (1.2), contains some complete $\Gamma[v,w]$, $FR[v,w]$, $FI[v,w]$, or $\Gamma IR[v,w]$ shock, that is, let us consider Cases 7, 8 and 15-22; suppose also that $f''(w) = g''(w)$ and $f'''(w) = g'''(w)$ at all w which occur as above. (Note: w is always either u_1 or u_3). Let m and M be as defined in Theorem 2. Then for any given function h such that $h'' > 0$ and $h''(w) = f''(w)$, $h'''(w) = f'''(w)$, there exists $\epsilon > 0$ such that if $\|f-h\|_{C^4[m,M]} < \epsilon$, $\|g-h\|_{C^4[m,M]} < \epsilon$, then our proposed solution is single valued, and it satisfies the entropy condition.

Proof. The proof consists of several lemmas.

Lemma 3.1. The map $T: C^4[v,w] \times C^4[v,w] \rightarrow C^1[v,w]$, $T(f,g) = \gamma$, where γ satisfies (2.12), (2.13), is continuous for $f'' > 0$, $g'' > 0$. The map $S_s(f,g) = \int_{w_0}^s T(f,g)(s) = \gamma'(s)$ satisfies

$$|(DS_s)(f,g)(p,q)| \leq C|s-w| \|(p,q)\|_{C^4[v,w]}, \quad (3.8)$$

for all p, q in $C^4[v,w]$ such that $p''(w) = q''(w) = p'''(w) = q'''(w) = 0$, where $C > 0$ does not depend on $p, q,$ or s .

Proof. From (2.14) we have

$$\gamma(s) = \frac{g(s) - g(w)}{s - w} \quad (3.9)$$

$$= \int_w^s \exp\left(\int_s^r \frac{f''(z)(w-z) dz}{f'(w) - f'(z) - f'(z)(w-z)}\right) \frac{g(w) - g(r) - g'(r)(w-r)}{(w-r)^2} dr$$

= (def.) $T_s(f, g)$. Clearly T_s is a continuous and differentiable mapping from $\{f | f \in C^4[v, w], f'' > 0\} \times \{g | g \in C^4[v, w], g'' > 0\}$ to \mathbb{R} , for $s \in (w, v)$. However it is necessary to show that $DT_s(f, g)$ is bounded independent of s , and independent of the choice of (f, g) from a neighborhood of (h, h) .

Define $T_w(f, g)$ to equal $g'(w)$. We prove that $s \rightarrow T_s(f, g)$ is continuous at w , as follows. We have:

$$\gamma(s) = T_s(f, g) = \frac{g(s) - g(w)}{s - w} \quad (3.10)$$

$$= \int_v^s \exp \left(\int_s^r \frac{f''(z)(w-z) dz}{\int_w^z f''(\theta)(\theta-w) d\theta} \right) \frac{\int_w^r g''(\theta)(\theta-w) d\theta}{(w-r)^2} dr$$

Note that

$$\exp \left(\int_s^r \frac{f''(z)(w-z) dz}{\int_w^z f''(\theta)(\theta-w) d\theta} \right) \quad (3.11)$$

$$= \exp \left(\int_s^r \frac{2}{w-z} + \frac{2 \int_w^z f'''(\theta)(\theta-w)^2 d\theta}{(w-z)(f''(z)(z-w)^2 - \int_w^z f'''(\theta)(\theta-w)^2 d\theta)} dz \right)$$

$$= \frac{(s-w)^2}{(r-w)^2} \exp \left(\int_s^r \frac{\int_w^z f'''(\theta)(\theta-w)^2 d\theta}{(w-z) \int_w^z f''(\theta)(\theta-w) d\theta} dz \right).$$

Thus

$$|\gamma(s) - \frac{g(s) - g(w)}{s - w}| \quad (3.12)$$

$$< (s-w)^2 \int_s^v \exp \left(\int_s^r \frac{2 \|f'''\|_\infty}{3(\inf(f''))} dz \right) \frac{\|g''\|_\infty}{(r-w)^2} dr$$

$$= (s-w)^2 \left(\frac{1}{s-w} - \frac{1}{v-w} \right) \frac{\|g''\|_\infty}{2} \exp \left(\frac{2 \|f'''\|_\infty (v-w)}{3(\inf(f''))} \right).$$

and so we see that $\lim_{s \rightarrow w} \gamma(s) = g'(w)$; thus $s \rightarrow T_s(f, g)$ is continuous on $[v, w]$. The sup norms and infimums used above and henceforth are all taken over $[v, w]$.

Next,

$$\begin{aligned}
 (DT_s)(f, g)(p, q) &= \frac{q(s) - q(w)}{s - w} & (3.13) \\
 &- \int_v^s \exp \left(\int_s^r \frac{f''(z)(w-z)}{\int_w^z f''(\theta)(\theta-w) d\theta} dz \right) \\
 &\cdot \left[\left(\int_s^r \frac{p''(z)(w-z) \int_w^z f''(\theta)(\theta-w) d\theta - f''(z)(z-w) \int_w^z p''(\theta)(\theta-w) d\theta}{\left[\int_w^z f''(\theta)(\theta-w) d\theta \right]^2} dz \right) \right. \\
 &\cdot \left. \int_w^r \frac{g''(\theta)(\theta-w)}{(r-w)^2} d\theta + \int_w^r \frac{q''(\theta)(\theta-w)}{(r-w)^2} d\theta \right] dr
 \end{aligned}$$

Thus

$$\begin{aligned}
 |(DT_s)(f, g)(p, q)| &\leq \|q'\|_\infty & (3.14) \\
 &+ \int_s^v \frac{(s-w)^2}{(r-w)^2} \exp \left(\frac{2\|f'''\|_\infty (v-w)}{3(\inf(f''))} \right) \\
 &\cdot \left[\left(\int_s^r \left[\int_w^z f''(\theta)(\theta-w) d\theta \right]^{-2} \left[(p''(w) + \int_w^z p'''(\theta) d\theta)(w-z) \int_w^z f''(\theta)(\theta-w) d\theta \right. \right. \right. \\
 &- \left. \left. \frac{1}{2} f''(z)(z-w)(p''(w)(z-w)^2 - \int_w^z p'''(\theta)((\theta-w)^2 - (z-w)^2) d\theta) \right] dz \right) \frac{\|g''\|_\infty}{2} \\
 &\left. + \frac{1}{2} \frac{q''(w)(r-w)^2 - \int_w^r q'''(\theta)[(\theta-w)^2 - (r-w)^2] d\theta}{(r-w)^2} \right] dr.
 \end{aligned}$$

Since only perturbations fixing $f''(w)$, $g''(w)$, $f'''(w)$, $g'''(w)$ are considered, we have $p''(w) = q''(w) = p'''(w) = q'''(w) = 0$. Thus

$$\begin{aligned}
 (3.17) \quad & \|(DT_s)_{(f,g)}(p,q)\| \leq \|q'\|_\infty \\
 & + \int_s^v \frac{(s-w)^2}{(r-w)^2} \exp\left(\frac{2\|f'''\|_\infty(v-w)}{3(\inf(f''))}\right) \\
 & \cdot \left[\frac{\|p'''\|_\infty \|f''\|_\infty \left(\frac{1}{2} + \frac{2}{3}\right) \|g''\|_\infty}{(\inf(f''))^2 \left(\frac{1}{4}\right)} + \|q'''\|_\infty \frac{(r-w)}{3} \right] dr \\
 & \leq \|q'\|_\infty + \exp\left(\frac{2\|f'''\|_\infty(v-w)}{3(\inf(f''))}\right) \\
 & \left[\frac{\|p'''\|_\infty \|f''\|_\infty \|g''\|_\infty}{(\inf(f''))^2} \left(\frac{5}{3}\right) \left(\frac{1}{s-w} - \frac{1}{v-w}\right) \right. \\
 & \left. + \frac{1}{3} \|q'''\|_\infty (\ln(v-w) - \ln(s-w)) \right] \cdot (s-w)^2,
 \end{aligned}$$

and so we see that $\|(DT_s)_{(f,g)}\|$ is independent of s , $w \leq s \leq v$, and also independent of the choice of (f,g) from a sufficiently small neighborhood of (h,h) . Therefore by the Mean Value Theorem the map $(f,g,s) \mapsto \gamma(s)$ is locally Lipschitz for each s , with a Lipschitz constant independent of s . Thus $(f,g) \mapsto \gamma$ is a continuous mapping from $C^3[w,v] \times C^3[w,v] \rightarrow C[w,v]$.

Next,

$$\begin{aligned}
 (3.18) \quad & S_s(f,g) = \gamma'(s) = \frac{g'(s)(s-w) - g(s) - g(w)}{(s-w)^2} \\
 & - \frac{g(w) - g(s) - g'(s)(w-s)}{(s-w)^2} - \int_w^s \exp\left(\int_s^r \frac{f''(z)(w-z)}{\int_w^z f''(0)(0-w) d\theta}\right) \\
 & \cdot \left(\frac{-f''(s)(w-s)}{\int_w^s f''(0)(0-w) d\theta} \right) \frac{\int_w^r g''(0)(0-w) d\theta}{(r-w)^2} dr.
 \end{aligned}$$

Differentiating with respect to f and g , we have

$$\begin{aligned}
 & (DS_s)(f, g)(p, q) \tag{3.17} \\
 &= (w-s) \frac{[p''(s) \int_w^s f''(\theta)(\theta-w) d\theta - f''(s) \int_w^s p''(\theta)(\theta-w) d\theta]}{[\int_w^s f''(\theta)(\theta-w) d\theta]^2} \\
 &\quad \cdot \int_v^s \exp\left(\int_s^r \frac{f''(z)(w-z)}{\int_w^z f''(\theta)(\theta-w) d\theta} dz\right) \frac{\int_w^r g''(\theta)(\theta-w) d\theta}{(r-w)^2} dr \\
 &\quad + \frac{f''(s)(w-s)}{\int_w^s f''(\theta)(\theta-w) d\theta} \int_v^s \exp\left(\int_s^r \frac{f''(z)(w-z)}{\int_w^z f''(\theta)(\theta-w) d\theta} dz\right) \\
 &\quad \cdot \left[\left(\int_s^r \left[\int_w^z f''(\theta)(\theta-w) d\theta \right]^{-2} (w-z) \left[p''(z) \int_w^z f''(\theta)(\theta-w) d\theta \right. \right. \right. \\
 &\quad \left. \left. \left. - f''(z) \int_w^z p''(\theta)(\theta-w) d\theta \right] dz \right) \int_w^r \frac{g''(\theta)(\theta-w)}{(r-w)^2} d\theta + \int_w^r \frac{q''(\theta)(\theta-w)}{(r-w)^2} d\theta \right] dr \\
 &= \frac{(w-s) [\int_w^s p'''(\theta) d\theta \int_w^s f''(\theta)(\theta-w) d\theta + \frac{f''(s)}{2} \int_w^s p'''(\theta)(\theta-w)^2 - (s-w)^2 d\theta]}{[\int_w^s f''(\theta)(\theta-w) d\theta]^2} \\
 &\quad \cdot \int_v^s \left(\frac{s-w}{r-w} \right)^2 \exp\left(\int_s^r \frac{\int_w^z f'''(\theta)(\theta-w)^2 d\theta}{(w-z) \int_w^z f''(\theta)(\theta-w) d\theta} dz\right) \int_w^r \frac{g''(\theta)(\theta-w) d\theta}{(r-w)^2} dr \\
 &\quad + \frac{f''(s)(w-s)}{\int_w^s f''(\theta)(\theta-w) d\theta} \int_v^s \exp\left(\int_s^r \frac{\int_w^z f'''(\theta)(\theta-w)^2 d\theta}{(w-z) \int_w^z f''(\theta)(\theta-w) d\theta} dz\right) \left(\frac{s-w}{r-w} \right)^2 \\
 &\quad \cdot \left[\int_s^r (w-z) \left[\int_w^z f''(\theta)(\theta-w) d\theta \right]^{-2} \right.
 \end{aligned}$$

$$\begin{aligned}
& \cdot \left[\int_w^z p'''(\theta) d\theta \int_w^z f''(\theta)(\theta-w) d\theta \right. \\
& + f''(z) \int_w^z \frac{p'''(\theta)}{2} ((\theta-w)^2 - (z-w)^2) d\theta \left. \right] dz \\
& \cdot \left[\int_w^r \frac{g''(\theta)(\theta-w)}{(r-w)^2} d\theta - \int_w^r \frac{g'''(\theta)((\theta-w)^2 - (r-w)^2)}{2(r-w)^2} d\theta \right] dr.
\end{aligned}$$

Note that, since $p'''(w) = 0$,

$$\int_w^s p'''(\theta) d\theta = - \int_w^s p''''(\theta)((\theta-w) - (s-w)) d\theta, \quad (3.18)$$

and

$$\int_w^z p'''(\theta)(\theta-w)^2 d\theta = \int_w^z \frac{1}{3} p''''(\theta) ((z-w)^3 - (\theta-w)^3) d\theta. \quad (3.19)$$

Thus

$$\begin{aligned}
(DS_s)_{(f,g)}(p,q) &= \left[(w-s) \left[\int_w^s f''(\theta)(\theta-w) d\theta \right]^{-2} \right. \\
& \cdot \left[\int_w^s p''''(\theta) ((s-w) - (\theta-w)) d\theta \int_w^s f''(\theta)(\theta-w) d\theta \right. \\
& + f''(s) \int_w^s p''''(\theta) \left[\frac{(s-w)^3}{6} - \frac{(\theta-w)^3}{6} - \frac{(s-w)^2}{2} ((s-w) - (\theta-w)) \right] d\theta \left. \right] \\
& \cdot \int_w^s \left(\frac{s-w}{r-w} \right)^2 \exp \left(\int_s^r \frac{\int_w^z f'''(\theta)(\theta-w)^2 d\theta}{(w-z) \int_w^z f''(\theta)(\theta-w) d\theta} dz \right) \cdot \int_w^r \frac{g''(\theta)(\theta-w)}{(r-w)^2} d\theta dr
\end{aligned} \quad (3.20)$$

$$\begin{aligned}
& + \frac{f''(s)(w-s)}{\int_w^s f''(\theta)(\theta-w) d\theta} \int_v^s \left(\frac{s-w}{r-w}\right)^2 \exp\left(\int_s^r \frac{\int_w^z f'''(\theta)(\theta-w)^2 d\theta}{(w-z) \int_w^z f''(\theta)(\theta-w) d\theta} dz\right) \\
& \cdot \left[\left(\int_s^r (w-z) \left(\int_w^z f''(\theta)(\theta-w) d\theta\right)^{-2}\right.\right. \\
& \cdot \left.\left(\int_w^z p''''(\theta)((z-w) - (\theta-w)) d\theta \int_w^z f''(\theta)(\theta-w) d\theta\right.\right. \\
& \left. + f''(z) \int_w^z p''''(\theta) \left[\frac{(z-w)^3}{6} - \frac{(\theta-w)^3}{6} - \frac{(z-w)^2}{2} ((z-w) - (\theta-w))\right] d\theta\right) dz \\
& \cdot \int_w^r \frac{g''(\theta)(\theta-w)}{(r-w)^2} d\theta \\
& \left. + \int_w^r q''''(\theta) \left[\frac{(r-w)^3}{6} - \frac{(\theta-w)^3}{6} - \frac{(r-w)^2}{2} ((r-w) - (\theta-w))\right] d\theta\right] dr.
\end{aligned}$$

So

$$\begin{aligned}
| (DS_s)(f, g)(p, q) | & \leq \frac{\|p''''\|_\infty \|f''\|_\infty}{(\inf(f''))^2} (5) |s-w|^3 \quad (3.21) \\
& \cdot \left| \frac{1}{v-w} - \frac{1}{s-w} \right| \exp\left(\frac{2\|f'''\|_\infty (v-w)}{3(\inf(f''))}\right) \cdot \frac{\|g''\|_\infty}{2} \\
& + \frac{\|f''\|_\infty}{(\inf(f''))^2} |s-w| \exp\left(\frac{2\|f'''\|_\infty (v-w)}{3(\inf(f''))}\right) \\
& \cdot \left[\frac{\|p''''\|_\infty \|f''\|_\infty \|g''\|_\infty}{2(\inf(f''))^2} \cdot (5) \int_s^v \frac{1}{2(r-w)^2} |(r-w)^2 - (s-w)^2| dw \right. \\
& \left. + \int_s^v \frac{1}{(r-w)^2} \|q''''\|_\infty \cdot \frac{1}{8} \cdot (s-w)^2 dw \right]
\end{aligned}$$

Thus $\| (DS_s)(f, g) \| \leq C |s - w|$ for some $C > 0$, where C depends only on $\|f'''\|_\infty$, $\ln f''$, $\|g''\|_\infty$, and (v, w) .

Lemma 3.2. In a $\Gamma[v, w]$ shock, in the case where $f \equiv g$, $\gamma''(w) < f'''(w)$.

Proof. Recall that when $f \equiv g$, f' is a solution to (2.12). Thus $\gamma(s) = f'(s) + \sigma(s)$, where σ satisfies

$$\sigma'(s) = \sigma(s) \frac{f''(s)(s-w)}{\int_w^s f''(\theta)(\theta-w) d\theta}. \quad (3.22)$$

Thus

$$(s-w) \frac{d}{ds} \ln(\sigma(s)) = \frac{f''(s)(s-w)^2}{\int_w^s f''(\theta)(\theta-w) d\theta}. \quad (3.23)$$

Note that

$$\lim_{s \rightarrow w} \frac{f''(s)(s-w)^2}{\int_w^s f''(\theta)(\theta-w) d\theta} = 2. \quad (3.24)$$

Thus one may write

$$\sigma(s) = C(s-w)^2 \exp \left(\int_v^s \frac{\int_w^z f'''(\theta)(\theta-w)^2 d\theta}{(z-w) \int_w^z f''(\theta)(\theta-w) d\theta} dz \right) \quad (3.25)$$

One may observe that σ has 2 continuous derivatives at w if f has 3 continuous derivatives, and, $\sigma''(w) < 0$ if and only if $C < 0$.

Thus $\gamma''(w) < f'''(w)$ if and only if $\gamma < f'$. However

$$\gamma(v) = \frac{f(v) - f(w)}{v - w} < f'(v) \text{ since } f'' < 0.$$

We can now prove that for sufficiently small ϵ , $\|f - h\|_{C^4} < \epsilon$ and $\|g - h\|_{C^4} < \epsilon$, together with the hypotheses of Theorem 3, imply that overlap does not occur. It suffices to show that for ϵ sufficiently small, $\gamma(s) < f'(s)$, $w < s \leq v$. From this it follows that the line $y = x$ separates the two Γ -shocks in Cases 19 through 22.

Since when $f \equiv g \equiv h$, $\gamma(s) < f'(s)$ for $w < s \leq v$, and since γ depends continuously on f and g , we have that for any $\delta > 0$ there exists $\epsilon > 0$ such that $\|f - h\|_{C^4} < \epsilon$ and $\|g - h\|_{C^4} < \epsilon$ imply $\gamma(s) < f'(s)$ for $w + \delta \leq s \leq v$. For s near w , and $f \equiv g \equiv h$,

$$f''(s) - \gamma'(s) = (f'''(w) - \gamma''(w))(s-w) + o(s-w). \quad (3.26)$$

Since by Lemma 3.2 $f'''(w) - \gamma''(w) > 0$, for δ sufficiently small we have

$$f''(s) - \gamma'(s) > C_0(s-w) \quad (3.27)$$

for some $C_0 > 0$ and for $w \leq s \leq \delta$. By Lemma 3.1 and the Mean Value theorem, for $\|f - h\|_{C^4} < \epsilon$ and $\|g - h\|_{C^4} < \epsilon$

$$f''(s) - \gamma'(s) > (C_0 - \epsilon C)(s-w) \quad (3.28)$$

for $w \leq s < \delta$. For ϵ sufficiently small $C_0 - \epsilon C > 0$, and hence $f''(s) > \gamma'(s)$ for $w < s \leq \delta$. Since $\gamma(w) = f'(w)$, the result follows.

To finish the proof of Theorem 3, it must be shown that

$$\begin{aligned} W(k,s) &= (f''(s)\gamma(s) - f'(s)\gamma'(s)) (k-w) \\ &+ \gamma'(s)(f(k) - f(w)) - f''(s)(g(k) - g(w)) \geq 0, \end{aligned} \quad (3.29)$$

for all $k, s, w \leq k \leq s \leq v$. Recall that $W(s,s) = W(w,s) = 0$, and,

when $f \equiv g$, $\frac{\partial^2 W}{\partial k^2} = f''(k)(\gamma'(s) - f''(s))$ which is less than zero for

$w < s \leq v$. In fact, for s close to w ,

$$\left(\frac{\partial^2 W}{\partial k^2}\right) = f''(w)(\gamma''(w) - f'''(w))(s-w) + o(s-w). \quad (3.30)$$

On the other hand,

$$\begin{aligned} D_{(f,g)} \left(\frac{\partial^2 W}{\partial k^2}\right) (p,q) & \quad (3.31) \\ & = D_{(f,g)}(\gamma')(p,q)f''(k) + \gamma'(s)p''(k) - p''(s)g''(k) - f''(s)q''(k) \end{aligned}$$

Thus

$$\begin{aligned} & |D_{(f,g)} \left(\frac{\partial^2 W}{\partial k^2}\right) (p,q)| \quad (3.32) \\ & \leq O(s-w) \|(p,q)\|_{C^4} f''(k) + |\gamma'(s)p''(k) - p''(s)g''(k) - g''(s)q''(k)| \end{aligned}$$

Since we are considering only those tangent vectors p and q such that

$p''(w) = q''(w) = 0$, we have that $|p''(k)|$, $|p''(s)|$, and $|q''(k)|$ are

less than $(\|p\|_{C^4} + \|q\|_{C^4})|s-w|$. Thus for some $C_1 > 0$,

$$|D_{(f,g)} \left(\frac{\partial^2 W}{\partial k^2}\right) (p,q)| \leq C_1 \cdot |s-w| \cdot \|(p,q)\|_{C^4}. \quad (3.33)$$

Thus for $f \equiv g \equiv h$, $\frac{\partial^2 W}{\partial k^2} \leq C_0 \cdot |s-w|$ for some $C_1 > 0$; and for

$f = h + \epsilon p$, $g = h + \epsilon q$, where p and q satisfy $p''(w) = q''(w) = p'''(w) = q'''(w) = 0$,

$$\frac{\partial^2 W}{\partial k^2} \leq (\epsilon(C + C_1) \| (p, q) \|_{C^4} - C_0) |s - w| \leq 0 \quad (3.34)$$

for sufficiently small ϵ . Since under these conditions W is convex down, and $W = 0$ at $k = s$ and $k = w$, one concludes that $W \geq 0$ for $w < k \leq s \leq v$.///

Remark. In Theorems 2 and 3 one may, of course, fix f and perturb only g , or the other way around. In this case one chooses $h \equiv f$, or $h \equiv g$, respectively.

4. A Counterexample.

The following is an example of a C^∞ one parameter family (f, f_ϵ) of pairs of C^∞ functions such that $f = f_0$ and such that for certain initial data, the solution given in §2 does not satisfy the entropy condition for $\epsilon > 0$. However, we also give the correct entropy solution for this example.

Let $f(s) = s^2$, and $f_\epsilon(s) = s^2 + \epsilon s^3$. Consider the initial value problem

$$\frac{\partial}{\partial t} u(t, x, y) + \frac{\partial}{\partial x} f(u(t, x, y)) + \frac{\partial}{\partial y} f_\epsilon(u(t, x, y)) = 0, \quad (4.1)$$

$$u(0, x, y) = \delta \text{ for } x > 0 \text{ and } y < 0,$$

$$= 0 \text{ otherwise,}$$

where $\delta > 0$. Note that $f'_\epsilon > 0$ on $[0, \delta]$ for $\epsilon > -1/(3\delta)$. The solution given in §2 is described in Figure 13.

Proposition. If $f(s) = s^2$, $g(s) = f_\epsilon(s) = s^2 + \epsilon s^3$, then for no choice of $\epsilon > 0$, and δ such that $0 < \delta$ does the shock $\Gamma[\delta, 0]$ satisfy the

entropy condition, near the line $x = 0, y = 0$.

Proof. $\Gamma[\delta, 0]$ is described by the equations $x = f'(s)t, y = \gamma(s)t, 0 \leq s \leq \delta$, where γ satisfies

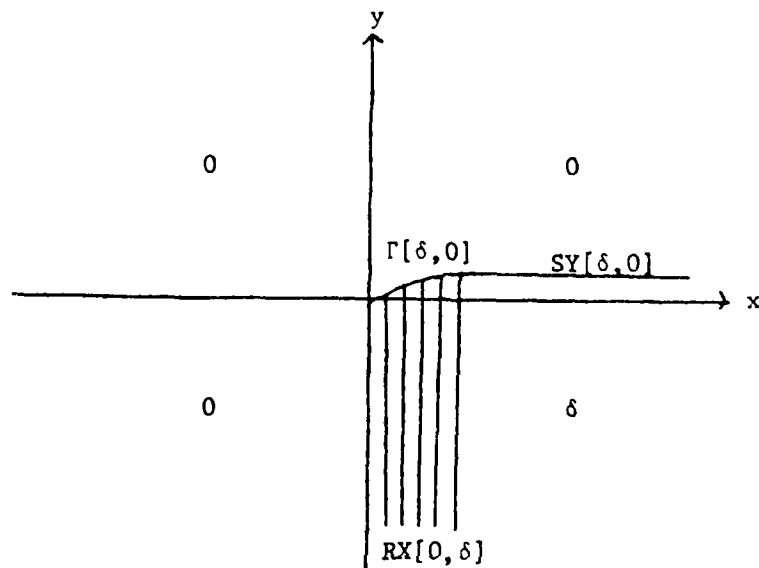

Figure 13

$$\gamma'(s) = 2 \frac{0-s^2 - \epsilon s^3 - \gamma(s)(0-s)}{0-s^2 - 2s(0-s)}, \quad (4.2)$$

$$= 2 \frac{\gamma(s)s - s^2 - \epsilon s^3}{s^2},$$

$$\gamma(\delta) = \frac{\delta^2 + \epsilon \delta^3}{\delta} = \delta + \epsilon \delta^2.$$

Thus one may solve to find

$$\gamma(s) = 2s - 2\epsilon s^2 \ln(s) + s^2 \left(\frac{1}{\delta} + \epsilon(2\ln(\delta) + 1) \right). \quad (4.3)$$

Also

$$\gamma'(s) = 2 - 4\epsilon s \ln(s) - 2\epsilon s + 2s \left(-\frac{1}{\delta} + \epsilon(2\ln(\delta) + 1)\right). \quad (4.4)$$

The shock wave $\Gamma[\delta, 0]$ satisfies the entropy condition if

$$\begin{aligned} W(k, s) &= (k-0)(2\gamma(s) - 2s\gamma'(s)) + (k^2-0)\gamma'(s) \\ &\quad - (k^2 + \epsilon k^3) \cdot 2 \geq 0 \text{ for } 0 \leq k \leq s \leq \delta. \end{aligned} \quad (4.5)$$

Note that $\frac{\partial W}{\partial k}(0, s) = 2\gamma(s) - 2s\gamma'(s)$. Solving $\gamma(s) - s\gamma'(s) = 0$,

we have

$$\begin{aligned} &2s - 2\epsilon s^2 \ln(s) + s^2 \left(-\frac{1}{\delta} + \epsilon(2\ln(\delta) + 1)\right) \\ &- \left[2s - 4\epsilon s^2 \ln(s) - 2\epsilon s^2 + 2s^2 \left(-\frac{1}{\delta} + \epsilon(2\ln(\delta) + 1)\right)\right] = 0; \end{aligned} \quad (4.6)$$

$$2\epsilon s^2 \ln(s) + 2\epsilon s^2 - s^2 \left(-\frac{1}{\delta} + \epsilon(2\ln(\delta) + 1)\right) = 0;$$

$$s^2 (2\epsilon \ln(s) + 2\epsilon - \left(-\frac{1}{\delta} + \epsilon(2\ln(\delta) + 1)\right)) = 0.$$

Thus $\gamma(s) = s\gamma'(s)$ if $s = 0$ or

$$\begin{aligned} s &= \exp\left(-\frac{1}{2\epsilon} \left(2\epsilon - \left(-\frac{1}{\delta} + \epsilon(2\ln(\delta) + 1)\right)\right)\right) \\ &= (\text{def.}) u_0. \end{aligned} \quad (4.7)$$

Note that u_0 is positive, and that $\lim_{\epsilon \rightarrow 0} u_0 = 0$ for $0 < \delta$. Furthermore, for $0 < s < u_0$, $\gamma(s) - s\gamma'(s) < 0$, hence, $\frac{\partial W}{\partial k}(0, s) < 0$ for these values of s , and thus $W < 0$ for these values of s , and k close to zero. Thus for any choice of δ greater than 0 our solution does not satisfy the entropy condition for small ϵ .

To keep the computations relatively simple, we give the correct

entropy solution for this example only in the case $\delta = 1$. In this case we will see that $\Gamma[1,0: u_0]$ satisfies the entropy condition. To the left of $x = f'(u_0)t$, a new rarefaction wave appears, and the shock wave passes between this new rarefaction wave and $RX[0,1]$. At $t = 1$ the solution looks like Figure 14.

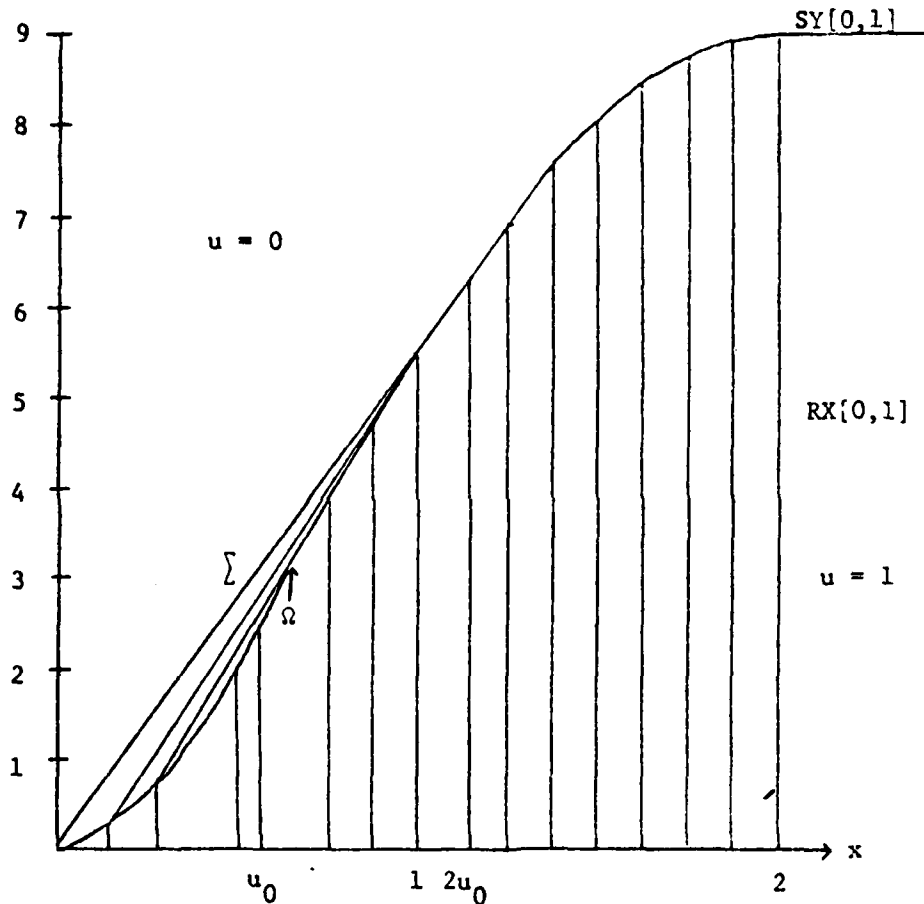

Figure 14. The solution to (4.1) with $\delta = 1$, $\epsilon = 8$

Let us call the new rarefaction wave Σ , and the continuation of $\Gamma[1,0: u_0]$, Ω . Let Ω have equations $x = f'(s)t$, $y = w(s)t$. Below Ω , the solution u equals s on plane sections $x = f'(s)t$. Above Ω , $u = v$ on plane sections .

$$y - f'_\epsilon(v)t = \frac{w'(s)}{f''(s)} (x - f'(v)t). \quad (4.8)$$

These plane sections meet the shock curve at $x = f'(s)t$, $y = w(s)t$ tangentially, as suggested by (4.8).

We now prove that this description is correct, and give an explicit expression for w and the relationship between s and v .

Since Ω is to satisfy Condition 2.1, we have

$$w'(s) = f''(s) \frac{f'_\epsilon(v) - f'_\epsilon(s) - w(s)(v-s)}{f(v) - f(s) - f'(s)(v-s)}. \quad (4.9)$$

Furthermore, by hypothesis, $u = v$ along a plane tangent to $x = f'(s)t$, $y = w(s)t$. Thus the following result, due to Guckenheimer [5], will allow us to get a different expression for $w'(s)$.

Theorem. If u is a solution to the Riemann Problem, then inside each region of rarefaction, the surfaces $u = v$ are sections of planes passing through the line $x = f'(v)t$, $y = f'_\epsilon(v)t$.

From this result we get

$$\frac{dy}{dx} = \frac{w'(s)}{f''(s)} = \frac{\Delta y}{\Delta x} = \frac{w(s) - f'_\epsilon(v)}{f'(s) - f'(v)} \quad (4.10)$$

Thus

$$\frac{v^2 + \epsilon v^3 - s^2 - \epsilon s^3 - w(s)(v-s)}{v^2 - s^2 - 2s(v-s)} = \frac{w(s) - 2v - 3\epsilon v^2}{2s - 2v}, \quad (4.11)$$

$$\begin{aligned} w(s) - 2v - 3\epsilon v^2 &= \frac{2}{(s-v)} (v^2 + \epsilon v^3 - s^2 - \epsilon s^3 - w(s)(v-s)) \\ &= 2(w(s) - v - s - \epsilon(v^2 + vs + s^2)). \end{aligned}$$

And thus

$$0 = \epsilon v^2 - (2\epsilon s)v + w(s) - 2s - 2\epsilon s^2. \quad (4.12)$$

So

$$v = s \pm (3s^2 - (w(s)/\epsilon) + (2s/\epsilon))^{1/2}. \quad (4.13)$$

Since $v < s$ is desired we choose the "-" sign. Now by (4.10)

$$\begin{aligned} w'(s) &= \frac{w(s) - (2v + 3\epsilon v^2)}{s - v} \\ &= 2 + 6\epsilon s - 4\epsilon \left(3s^2 + \frac{2s - w(s)}{\epsilon}\right)^{1/2}. \end{aligned} \quad (4.14)$$

Now, differentiating (4.13) with respect to s , and substituting (4.14), we compute

$$\begin{aligned} \frac{dv}{ds} &= 1 - \frac{6s + \frac{2 - w'(s)}{\epsilon}}{2 \left(3s^2 + \frac{2s - w(s)}{\epsilon}\right)^{1/2}} \\ &= 1 - \frac{6s + \frac{2}{\epsilon} - \frac{1}{\epsilon} \left(2 + 6\epsilon s - 4\epsilon \sqrt{3s^2 + \frac{2s - w(s)}{\epsilon}}\right)}{2 \sqrt{3s^2 + \frac{2s - w(s)}{\epsilon}}} = -1. \end{aligned} \quad (4.15)$$

Thus $v = -s + c$. Since, as depicted in Figure 14, $v = 0$ when $s = u_0$, we have that $c = u_0$. Thus $v = u_0 - s$, and we expect that the surfaces $x = f'(s)t$, $y = w(s)t$, and $x = f'(v(s))t$, $y = f'_\epsilon(v(s))t$ meet when $s = v(s) = u_0 - s$; that is, at $s = u_0/2$.

We may now rewrite (4.10):

$$\begin{aligned} w'(s) &= \frac{w(s) - 2v - 3\epsilon v^2}{s - v} \\ &= \frac{w(s) + 2s - 2u_0 - 3\epsilon(s - u_0)^2}{2s - u_0} \end{aligned} \quad (4.16)$$

Thus we have a linear first order differential equation for w . The initial condition is $w(u_0) = \gamma(u_0)$. The solution is

$$\begin{aligned}
 w(s) &= \frac{1}{2} (s - u_0/2)^{1/2} \left[\int_{u_0}^s \frac{2z - 2u_0 - 3\epsilon(u_0 - z)^2}{(z - u_0/2)^{3/2}} dz + \right. & (4.17) \\
 &\quad \left. + \frac{2\gamma(u_0)}{(u_0/2)^{1/2}} \right], \\
 &= \frac{1}{2} \left[2(2 + 3\epsilon u_0) ((s - u_0/2) - (u_0/2))^{1/2} (s - u_0/2)^{1/2} \right. \\
 &\quad + 2u_0(1 + 3\epsilon u_0/4) (1 - (s - u_0/2))^{1/2} (2/u_0)^{1/2} \\
 &\quad \left. - 2\epsilon((s - u_0/2)^2 - (s - u_0/2)^{1/2}(u_0/2)^{3/2}) + 2\gamma(u_0)(2/u_0)^{1/2}(s - u_0/2)^{1/2} \right].
 \end{aligned}$$

Note that

$$\begin{aligned}
 w(u_0/2) &= (2u_0 - 3\epsilon u_0^2/2)/2 \\
 &= 2(u_0/2) - 3\epsilon(u_0/2)^2 = f'_\epsilon(u_0/2).
 \end{aligned}$$

Thus the two surfaces $x = f'(s)t$, $y = w(s)t$, and $x = f'(v(s))t$, $y = f'_\epsilon(v(s))t$, do meet at $s = v(s) = u_0/2$. Since by (4.3)

$$\begin{aligned}
 \gamma(u_0) &= 2u_0 - 2\epsilon(u_0)^2 \ln(u_0) + (\epsilon-1)(u_0)^2 & (4.18) \\
 &= 2\exp\left(-\frac{1+\epsilon}{2\epsilon}\right) - 2\epsilon \exp\left(-\frac{1+\epsilon}{2\epsilon}\right) \left(-\frac{1+\epsilon}{2\epsilon}\right) + (\epsilon-1)\exp\left(-\frac{1+\epsilon}{\epsilon}\right), \\
 &= 2u_0 + 2\epsilon u_0^2
 \end{aligned}$$

we have that

$$w(s) = -\epsilon(s - u_0/2)^2 + (2 + 3\epsilon u_0)(s - u_0/2) + u_0(1 + 3\epsilon u_0/4). \quad (4.19)$$

Thus

$$w'(s) = -2\epsilon\left(s - \frac{u_0}{2}\right) + 2 + 3\epsilon u_0, \quad (4.20)$$

$$w''(s) = -2\epsilon < 0, \text{ for } \epsilon > 0,$$

and we see that the shock curve $y = w(s)$, $x = f'(s) = 2s$ is concave down. Furthermore $w'(u_0/2) = 2 + 3\epsilon u_0 = 2 + 6\epsilon(u_0/2) = f''_\epsilon(u_0/2)$.

Thus the shock curve meets the curve $y = f'_\epsilon(v)$, $x = f'(v)$ tangentially.

To verify the entropy condition for Ω , it is necessary to show that

$$W(k,s) = (2w(s) - 2sw'(s))(k - (u_0 - s)) \quad (4.21)$$

$$+ (k^2 - (u_0 - s)^2)w'(s) - (k^2 + \epsilon k^3 - (u_0 - s)^2 - \epsilon(u_0 - s)^3)2 \geq 0,$$

for $u_0 - s < k < s$, $(u_0/2) \leq s \leq u_0$. Substituting (4.19), we have

$$\begin{aligned} W(k,s) &= (k + s - u_0)(2\epsilon s^2 - 2\epsilon u_0^2) + (k^2 - u_0^2 + 2u_0s - s^2)[4\epsilon u_0 - 2\epsilon s] \\ &\quad - 2[\epsilon k^3 - \epsilon u_0^3 + 3\epsilon u_0^2 s - 3\epsilon u_0 s^2 + \epsilon s^3]. \end{aligned} \quad (4.22)$$

It is now easily checked that $W(s,s) = W(u_0 - s,s) = 0$; this verifies Condition 2.1, the Rankine-Hugoniot condition, for Ω . Next

$$\frac{\partial W}{\partial k}(k,s) = (2\epsilon s^2 - 2\epsilon u_0^2) + 2k(4\epsilon u_0 - 2\epsilon s) - 6\epsilon k^2 \quad (4.23)$$

$$\begin{aligned}
&= 0 \text{ for } k = -\frac{1}{3}s + \frac{2}{3}u_0 \pm \frac{1}{3}(2s - u_0) \\
&= \frac{1}{3}s + \frac{1}{3}u_0 \text{ or } u_0 - s.
\end{aligned}$$

Thus for each s , $W(k,s)$ is cubic in k , with a single root at $k = s$ and a double root at $k = u_0 - s = v$. Since these are the only zeros of W , and the leading coefficient of W is $-2\epsilon < 0$, and $v < s$, we conclude that $W \geq 0$ for $v \leq k \leq s$.

Note that in the above proof ϵ may be arbitrarily large.

Furthermore $\lim_{\epsilon \rightarrow \infty} u_0 = e^{-.5} \approx .61 < 1$. Also, the double root of W at $k = v$ shows that Ω is a two dimensional analog of a one dimensional scalar contact discontinuity.

Finally, to prove that $\Gamma[1, 0; u_0]$ satisfies the entropy condition for all $\epsilon > 0$, it suffices to show

$$W(k,s) = (2\gamma(s) - 2s\gamma'(s))(k-0) \quad (4.24)$$

$$+ (k^2-0)\gamma'(s) - 2(k^2 + \epsilon k^3 - 0) \geq 0,$$

for $0 \leq k \leq s$, $u_0 = e^{-\frac{1+\epsilon}{2\epsilon}} \leq s \leq 1$. Substituting (4.3) and (4.4), we have

$$\begin{aligned}
W(k,s) &= (2(2s - 2\epsilon s^2 \ln(s) + (\epsilon-1)s^2) \\
&\quad - 2s(2 - 4\epsilon s \ln(s) - 2s))k \\
&\quad + k^2(2 - 4\epsilon s \ln(s) - 2s) - 2(k^2 + \epsilon k^3) \\
&= 2k(s^2(2\epsilon \ln(s) + \epsilon + 1)) + k^2(-4\epsilon s \ln(s) - 2s) - 2\epsilon k^3.
\end{aligned} \quad (4.25)$$

Thus $W(k,s) = 0$ if $k = 0$, or if $k = s$. We have already seen, in (4.5),

that $\frac{\partial W}{\partial k}(0, s) > 0$ if $s > u_0$, and $\frac{\partial W}{\partial k}(0, u_0) = 0$. Since W is cubic in k with leading coefficient $-2\epsilon < 0$, we may conclude that $W \geq 0$

for $0 \leq k \leq s$, $u_0 \leq s \leq 1$.

ACKNOWLEDGEMENT

This paper is an edited version of a doctoral dissertation submitted in partial fulfillment of the requirements for the degree of Doctor of Philosophy in the Horace H. Rackham School of Graduate Studies at The University of Michigan. This dissertation was written under the direction of Professor Joel A. Smoller, to whom I am deeply grateful for inspiration and guidance.

Microfilm copies of this dissertation are available for study at the Library of Congress and The University of Michigan Library.

REFERENCES

1. E. Conway, and J. Smoller, Global Solutions of the Cauchy Problem for Quasi-Linear First Order Equations in Several Space Variables, *Comm. Pure Appl. Math.* 19 (1966), 95-105.
2. J. Glimm, Solutions in the Large for Nonlinear Systems of Equations, *Comm. Pure Appl. Math.* 18 (1965), 697-715.
3. J. Glimm, D. Marchesin, and O. McBryan, The Buckley-Leverett Equation: Theory, Computation, and Application, *Proceedings of the Third Meeting of the International Society for the Interaction of Mechanics and Mathematics*. Edinburgh, September 10-13, 1979 (to appear).
4. J. Glimm, D. Marchesin, and O. McBryan, Unstable Fingers in Two Phase Flow, *Comm. Pure Appl. Math.* 34(1981), 53-75.
5. J. Guckenheimer, Shocks and Rarefactions in Two Space Dimensions, *Arch. Rational Mech. Anal.* 59 no. 3, (1975) 281-291.
6. S. N. Kruzkov, Generalized Solutions of the Cauchy Problem in the Large for Nonlinear Equations of First Order, *Soviet Math. Dokl.* 10 no. 4 (1969), 785-788.
7. D. W. Peaceman, *Fundamentals of Numerical Reservoir Simulation* Developments in Petroleum Science 6, New York: Elsevier Scientific Publishing Company, 1977, 1-34.
8. Y. Val'ka, "Discontinuous Solutions of a Multidimensional Quasilinear Equation (Numerical Experiments)," *USSR Comp. Math. and Math. Physics*, vol. 8, no. 1 (1968), p. 257-264.
9. A. I. Vol'pert, The Spaces BV and Quasilinear Equations, *Math. USSR - Sb.* 2 no. 2 (1967), 225-267.

REPORT DOCUMENTATION PAGE		READ INSTRUCTIONS BEFORE COMPLETING FORM
1. REPORT NUMBER #2363	2. GOVT ACCESSION NO. ADA116 154	3. RECIPIENT'S CATALOG NUMBER
4. TITLE (and Subtitle) The Riemann Problem in Two Space Dimensions for a Single Conservation Law		5. TYPE OF REPORT & PERIOD COVERED Summary Report - no specific reporting period
		6. PERFORMING ORG. REPORT NUMBER
7. AUTHOR(s) David H. Wagner		8. CONTRACT OR GRANT NUMBER(s) DAAG29-80-C-0041
9. PERFORMING ORGANIZATION NAME AND ADDRESS Mathematics Research Center, University of 610 Walnut Street Madison, Wisconsin 53706 Wisconsin		10. PROGRAM ELEMENT, PROJECT, TASK AREA & WORK UNIT NUMBERS Work Unit Number 1 - Applied Analysis
11. CONTROLLING OFFICE NAME AND ADDRESS U. S. Army Research Office P. O. Box 12211 Research Triangle Park, North Carolina 27709		12. REPORT DATE April 1982
14. MONITORING AGENCY NAME & ADDRESS (if different from Controlling Office)		13. NUMBER OF PAGES 45
		15. SECURITY CLASS. (of this report) UNCLASSIFIED
16. DISTRIBUTION STATEMENT (of this Report) Approved for public release; distribution unlimited.		15a. DECLASSIFICATION/DOWNGRADING SCHEDULE
17. DISTRIBUTION STATEMENT (of the abstract entered in Block 20, if different from Report)		
18. SUPPLEMENTARY NOTES		
19. KEY WORDS (Continue on reverse side if necessary and identify by block number) Conservation laws, shock waves, two space dimensions.		
20. ABSTRACT (Continue on reverse side if necessary and identify by block number) Solutions are given for the partial differential equation $\frac{\partial}{\partial t} u(t,x,y) + \frac{\partial}{\partial x} f(u(t,x,y)) + \frac{\partial}{\partial y} g(u(t,x,y)) = 0$ with initial data constant in each quadrant of the (x,y) plane. This problem generalizes the Riemann Problem for equations in one space dimension. Although existence and uniqueness of solution are known, little is known concerning the qualitative behavior of solutions. <p style="text-align: right;">(continued)</p>		

ABSTRACT (continued)

When f and g are convex and $f \equiv g$, then our solutions satisfy the uniqueness, or entropy condition given by Kruzkov and Vol'pert. Under certain extra conditions on f and g , our solutions satisfy the entropy condition if f and g are convex and sufficiently close. A counterexample is given to show the necessity of these extra conditions on f and g . The correct entropy solution for this counter-example exhibits new and interesting phenomena.

**LATE
LME**