

AD-A116 163

HYDRONAUTICS INC LAUREL MD
TOWBOAT MANEUVERING SIMULATOR. VOLUME I. USERS GUIDE.(U)
MAY 79 P VAN DYKE

F/6 9/2

UNCLASSIFIED

7909-1

USCG-D-61-79

DOT-CG-840165-A

NL

1-1

2

3

4

5

6

7

8

9

0

1

2

3

4

5

6

7

8

9

0

1

2

3

4

5

6

7

8

9

0

1

2

3

4

5

6

7

8

9

0

1

2

3

4

5

6

7

8

9

0

1

2

3

END

DATE

7 82

DTIC

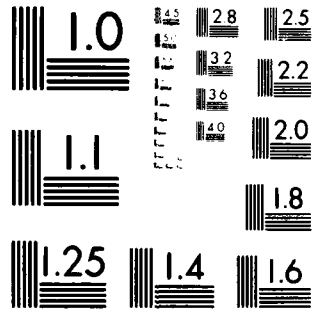

MICROCOPY RESOLUTION TEST CHART
NATIONAL BUREAU OF STANDARDS 1963-A

Report No. CG-D-61-79

⑤
⑬

TOWBOAT MANEUVERING SIMULATOR
VOLUME I - USERS GUIDE

AD A116763

PETER VAN DYKE



FINAL REPORT

MAY 1979

Document is available to the public through the
National Technical Information Service,
Springfield, Virginia 22151

Prepared for

U.S. DEPARTMENT OF TRANSPORTATION
United States Coast Guard
Office of Research and Development
Washington, D.C. 20590

DTIC FILE COPY

DTIC
ELECTE
JUN 28 1982

82 06 28 010

NOTICE

This document is disseminated under the sponsorship of the Department of Transportation in the interest of information exchange. The United States Government assumes no liability for its contents or use thereof.

The contents of this report do not necessarily reflect the official view or policy of the Coast Guard; and they do not constitute a standard, specification, or regulation.

This report, or portions thereof may not be used for advertising or sales promotion purposes. Citation of trade names and manufacturers does not constitute endorsement or approval of such products.

METRIC CONVERSION FACTORS

Symbol	When You Have	Multiply by	To Find	Symbol
LENGTH				
m	meters	39.37	inches	in
cm	centimeters	2.54	inches	in
mm	millimeters	25.4	inches	in
km	kilometers	0.62137	miles	mi
AREA				
m ²	square meters	10.764	square feet	sq ft
cm ²	square centimeters	1.547	square inches	sq in
ha	hectares (10,000 m ²)	2.471	acres	ac
MASS (weight)				
g	grams	0.03523	ounces	oz
kg	kilograms	2.2046	pounds	lb
ton	metric tons (1,000 kg)	2,204.6	short tons	st
VOLUME				
m ³	cubic meters	35.234	cubic feet	cu ft
l	liters	1.0567	quarts	qt
ml	milliliters	0.26417	fluid ounces	fl oz
dm ³	cubic decimeters	3.7854	liters	l
TEMPERATURE (temp)				
°C	Celsius temperature	1.8	Fahrenheit temperature	°F
°F	Fahrenheit temperature	0.5556	Celsius temperature	°C

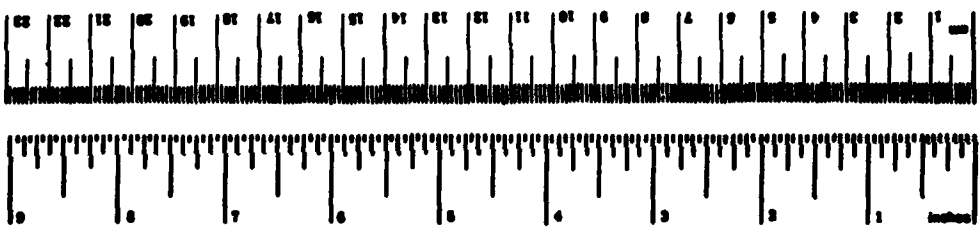

* 1 in = 2.54 centimeters. For other exact conversions and more detailed tables, see ANSI Z39.18, Publ. 298, *Units of Weight and Measure*, Price \$5.50, 50 Centing No. G13.1928.

Copy available to DTIC does not permit fully legible reproduction.

Technical Report Documentation Page

1. Report No. CG-D-61-79	2. Government Accession No. AD-A116163	3. Recipient's Catalog No.	
4. Title and Subtitle Towboat Maneuvering Simulator Volume I - Users Guide		5. Report Date May 1979	6. Performing Organization Code
		8. Performing Organization Report No. 7909-1	
7. Author(s) Peter Van Dyke		10. Work Unit No. (TRAIS)	
9. Performing Organization Name and Address Hydronautics, Inc. Laurel, Maryland		11. Contract or Grant No. DOT-CG-840165-A	
		13. Type of Report and Period Covered Final Report Sep 1978 - May 1979	
12. Sponsoring Agency Name and Address U. S. Department of Transportation United States Coast Guard Office of Research and Development Washington, D. C. 20590		14. Sponsoring Agency Code G-DSA-1	
15. Supplementary Notes The U. S. Coast Guard's technical representative for the work described herein was David A. Walden.			
16. Abstract The Towboat Maneuvering Simulator consists of a mathematical description of the hydrodynamic response of an integrated river tow embodied in a computer program running continuously on a computer, with a control console and other graphic and hard copy devices attached for input and output. It is thus a real time, interactive simulator, constantly responding to console commands and immediately updating the console displays. This volume describes the use of the simulator, provides a block diagram of the program flow, and presents sample input and output.			
17. Key Words Towboat Maneuvering		18. Distribution Statement Document is available through the National Technical Information Service, Springfield, VA 22161.	
19. Security Classif. (of this report) Unclassified	20. Security Classif. (of this page)	21. No. of Pages	22. Price

TABLE OF CONTENTS

	<u>Page</u>
1.0 GENERAL DESCRIPTION	1
2.0 CONSOLE DESIGN	5
3.0 SIMULATOR INPUTS	9
4.0 SIMULATOR OUTPUTS	12
5.0 CONSOLE CONNECTIONS	21
6.0 SIMULATOR OPERATION	24
7.0 WIRING DIAGRAMS	27
8.0 SCENARIO PARAMETERS	30

Accession For	
NTIS GRA&I	<input checked="" type="checkbox"/>
DTIC TAB	<input type="checkbox"/>
Unannounced	<input type="checkbox"/>
Justification	
By _____	
Distribution/ _____	
Availability Codes	
Dist	Special
A	

HYDRONAUTICS, Incorporated

-ii-

	<u>Page</u>
Figure 1 - Simulator Problems	2
Figure 2 - Simulator Hardware	3
Figure 3 - Computer Program Flow	4
Figure 4 - Towboat Console	6
Figure 5 - Simulator Console	7
Figure 6 - Similator Console	8
Figure 7 - Sample Inputs	10
Figure 8 - Computer Program Inputs and Outputs	11
Figure 9 - Printer Output	13
Figure 10 - Berwick Bay, Louisiana Chart	14
Figure 11 - Operator Strategy	15
Figure 12 - Berwick Bay Passage	16
Figure 13 - Current Map	17
Figure 14 - No Current	18
Figure 15 - Upstream and Bridge Currents	19
Figure 16 - Upstream and Bridge Currents	20
Figure 17 - Wiring Diagram 1	28
Figure 18 - Wiring Diagram 2	29

TOWBOAT MANEUVERING SIMULATOR
USER'S GUIDE

1.0 GENERAL DESCRIPTION

The Towboat Maneuvering Simulator consists of a mathematical description of the hydrodynamic response of an integrated river tow embodied in a computer program running continuously on a computer, with a control console and other graphic and hard copy devices attached for input and output. It is thus a real time, interactive simulator, constantly responding to console commands and immediately updating the console displays. Figure 1 illustrates the cumulative relative cost of a typical simulator as more operator-specific equipment is added to the basic mathematical model. The three order-of-magnitude increase in cost is a result of the image projection equipment required to provide visual displays. Typical problems which can be run are also shown in this figure.

Figure 2 shows the components of the simulator. All of the components except the console were supplied by the U.S. Coast Guard, and the console was designed and constructed by HYDRONAUTICS, Incorporated.

The logic flow of the computer program is illustrated in Figure 3. The programs are described in detail in Volume II of this report.

MATHEMATICS

OPERATIONS

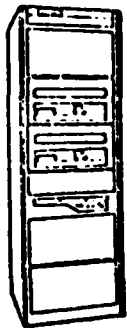

COMPUTER

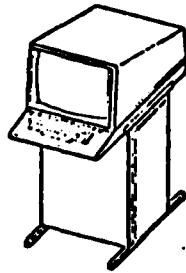

VISUAL/RADAR

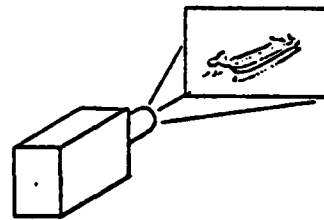
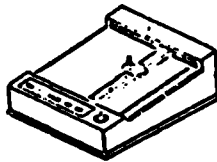
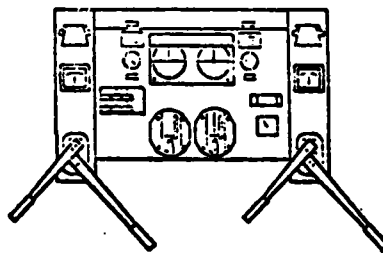

IMAGE PROJECTION



PLOTTER



CONSOLE

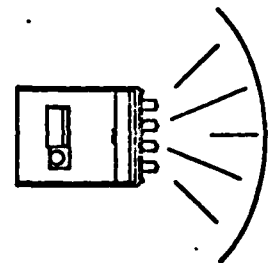

COMPLETE WHEELHOUSE

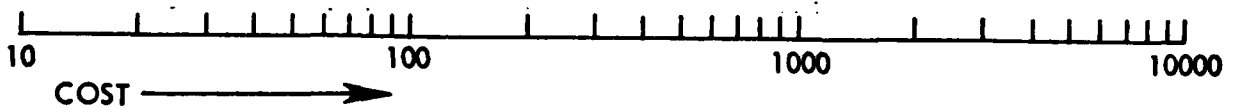

- ENVIRONMENTAL - WIND, WAVES, CURRENT
- SHIP CHARACTERISTICS - DESIGN ANALYSIS, BOW THRUSTER
- CHANNEL / PORT CONFIGURATION - BRIDGES, LIGHTS, MOORINGS
- EMERGENCY MANEUVERS
- EQUIPMENT FAILURE

FIGURE 1 - SIMULATOR PROBLEMS

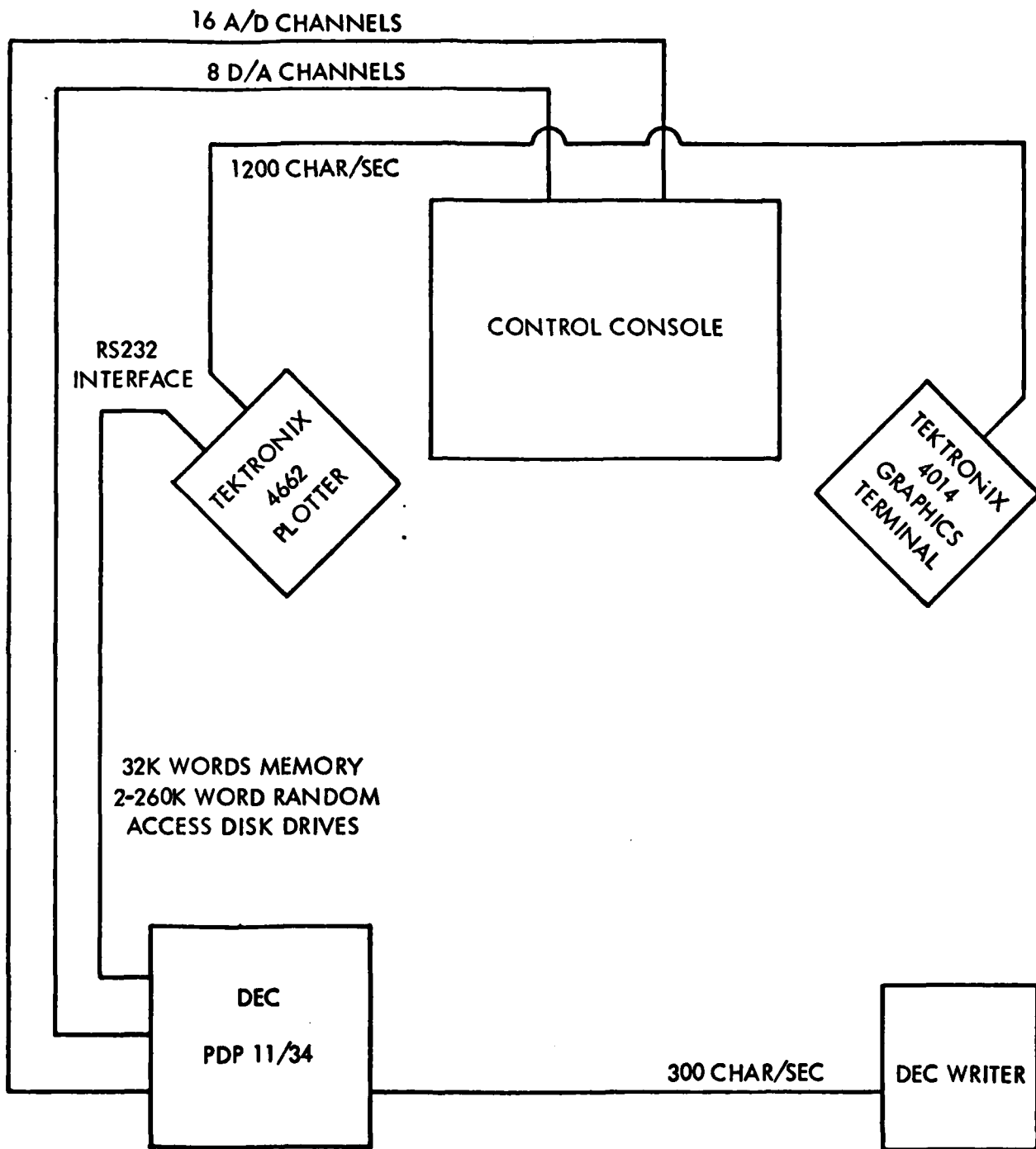

FIGURE 2 - SIMULATOR HARDWARE

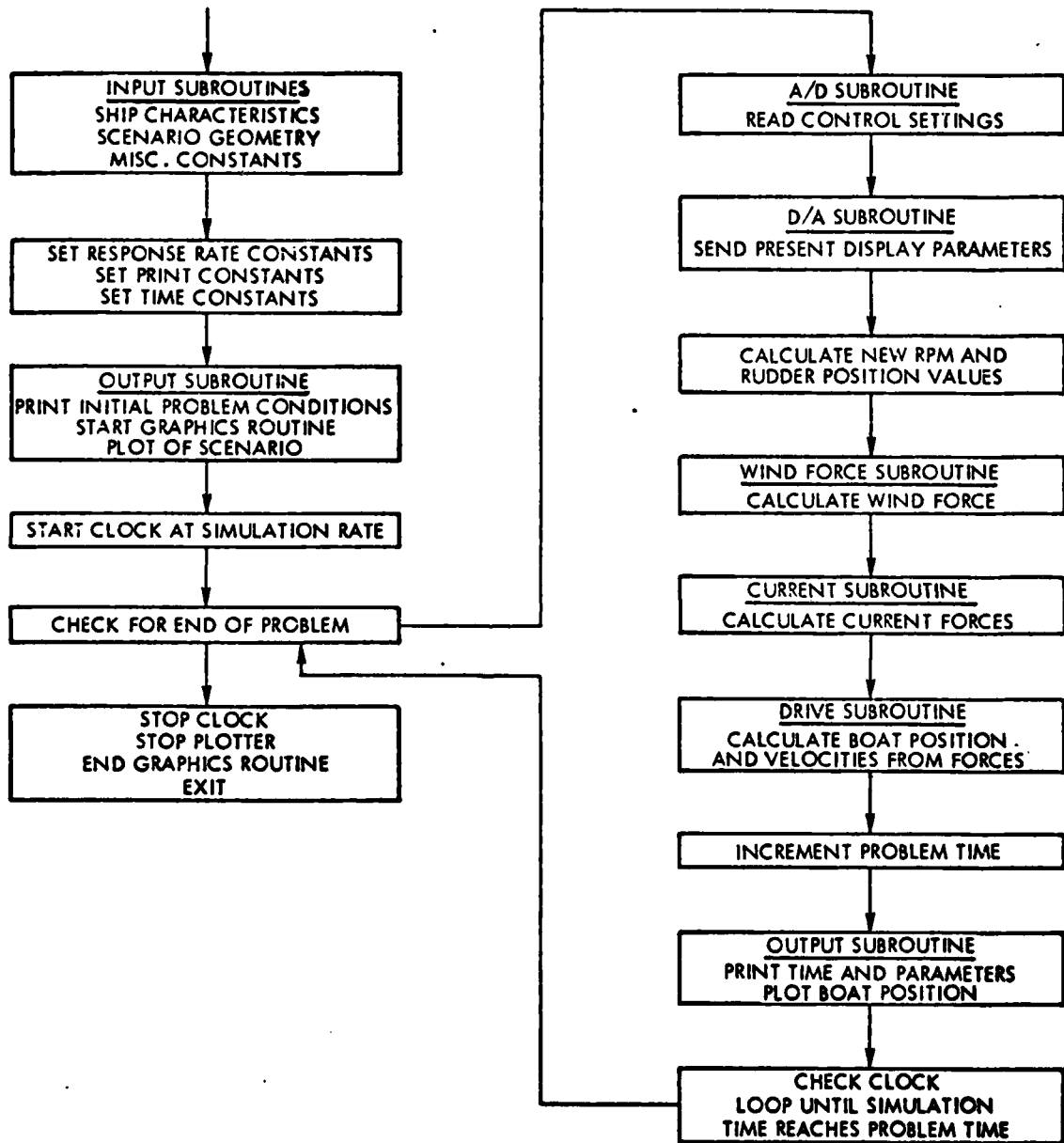

FIGURE 3 - COMPUTER PROGRAM FLOW

HYDRONAUTICS, Incorporated

-5-

2.0 CONSOLE DESIGN

The console design was based on the console in a towboat built by Dravo Corporation. Drawings for the console and the control handles were supplied by Dravo to HYDRONAUTICS to assist in our design. Figure 4 is a picture of the actual console on which our design is based; Figures 5 and 6 show the layout and overall dimensions.

HYDRONAUTICS, INCORPORATED



FIGURE 4 - TOWBOAT CONSOLE

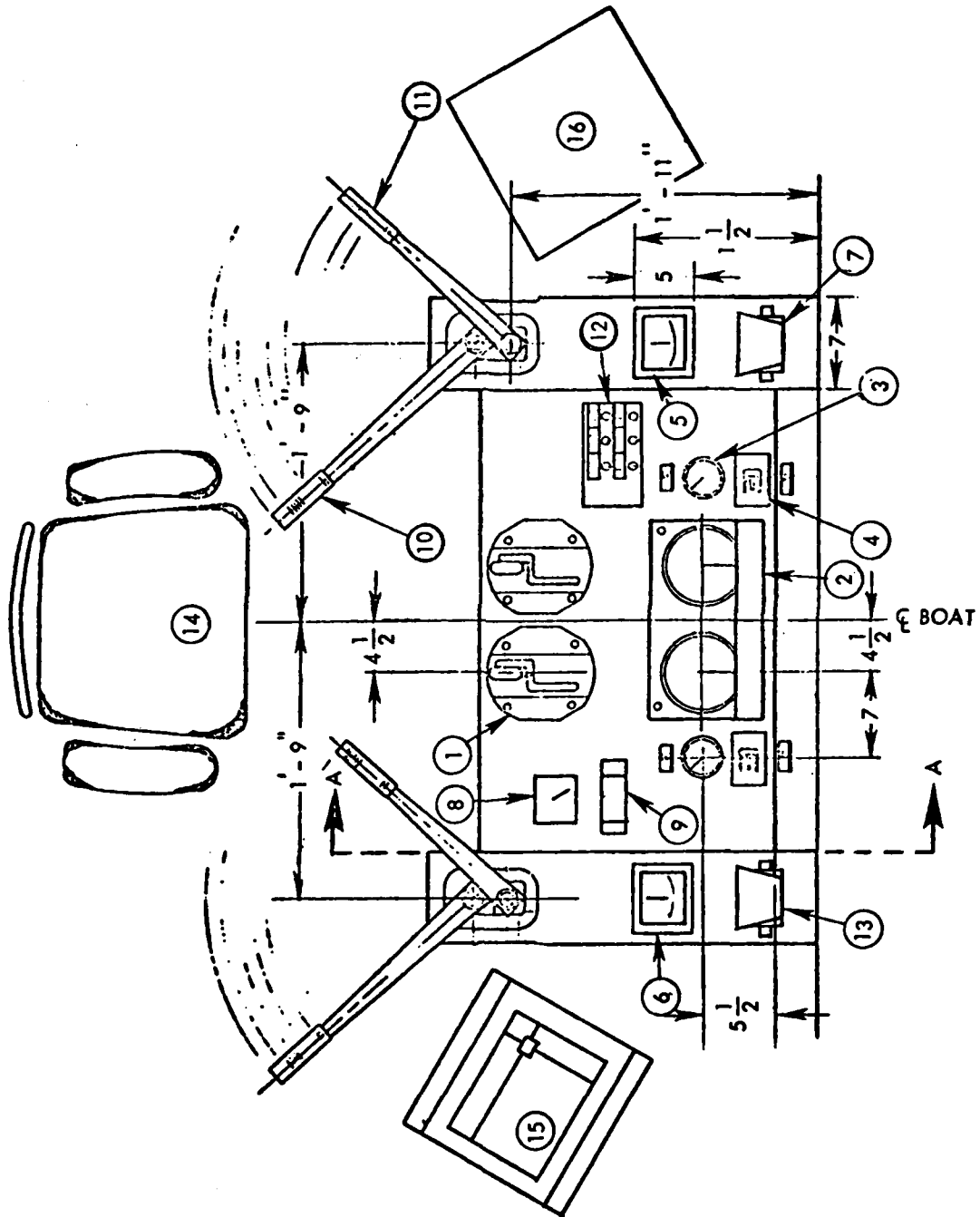

FIGURE 5 - SIMULATOR CONSOLE

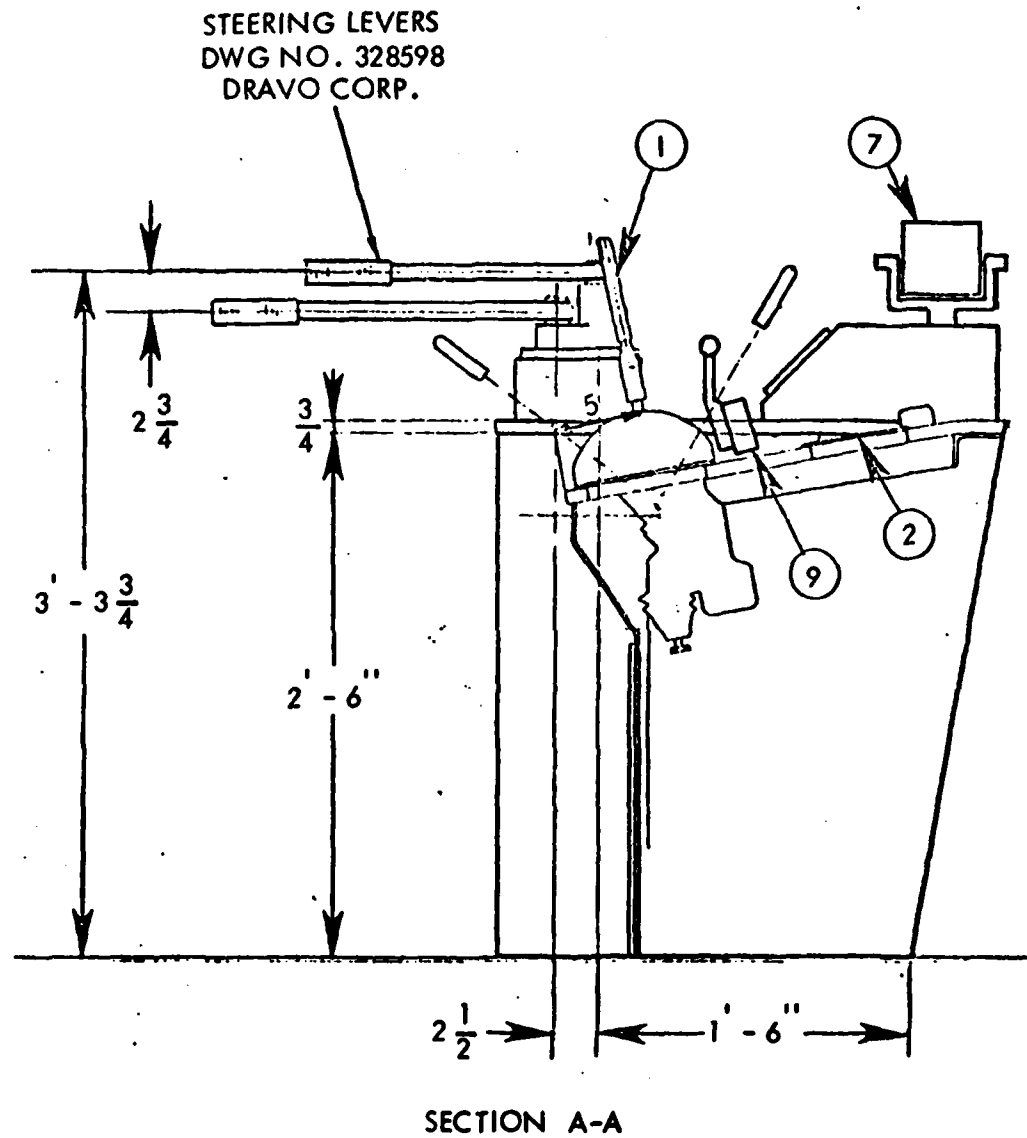

FIGURE 6 - SIMULATOR CONSOLE .

3.0 SIMULATOR INPUTS

Input data on initial conditions, ship characteristics, and scenario definition come into the problem through the three input subroutines. These are described in Volume II of this report. Figure 7 illustrates typical initial conditions, ship, and scenario definitions which can be combined to produce a specific problem. For example, using DTQ03, DTR31, and DTS01 we would have the EXXON NASHVILLE in the Berwick Bay Bridge Scenario, moving up-river with the simulation at twice real time. The scenario input routine contains the waterway geometry, current, and wind conditions. The ship routine contains all coefficients and parameters for the tow to be used. The initial condition routine describes initial position, speed, rpm and rudder settings, and time constants for the tow in the scenario. The ship, current, and wind data necessary for these routines is described in Volume III of this report. Figure 8 lists the other inputs and outputs; the inputs all come from the console and are as numbered in Figure 5:

Port RPM Ordered	Figure 5 - 1 left
Starboard RPM Ordered	1 right
Steering Rudder Ordered	10
Flanking Rudder Ordered	11
Bow Thruster RPM Ordered	9
Stop Switch	12

Section 8, Scenario Parameters, provides specific descriptions of many of the variables in the input routines which are used to set up the operating geometry.

HYDRONAUTICS, INCORPORATED

THIS COMMAND FILE LISTS THE EXAMPLES WHICH MAY BE RUN BY COPYING THE FILE DTQXX.FOR TO DTL10.FOR, COMPILING DTL10, AND RUNNING THE COMMAND FILE MAT10.COM

XX DESCRIPTION OF INITIALIZATION FILE

- 01 BERWICK BAY BRIDGE DOWNRIVER (2 X T)
- 02 BERWICK BAY BRIDGE DOWNRIVER
- 03 BERWICK BAY BRIDGE UPRIVER (2 X T)
- 04 BERWICK BAY BRIDGE UPRIVER

- 21 TANKER MANEUVERING IN PORT
- 22 TANKER MANEUVERING IN PORT (4 X T)

- 31 WILKINSON POINT DOWNRIVER (2 X T)
- 32 WILKINSON POINT UPRIVER (2 X T)

THIS COMMAND FILE LISTS THE EXAMPLES WHICH MAY BE RUN BY COPYING THE FILE DTRXX.FOR TO DTM10.FOR, COMPILING DTM10, AND RUNNING THE COMMAND FILE MAT10.COM

XX DESCRIPTION OF SHIP FILE

- 01 EXXON TENNESSEE
- 21 TWIN SCREW TANKER
- 22 SINGLE SCREW TANKER

- 31 EXXON NASHVILLE

THIS COMMAND FILE LISTS THE EXAMPLES WHICH MAY BE RUN BY COPYING THE FILE DTSXX.FOR TO DTM10.FOR, COMPILING DTM10, AND RUNNING THE COMMAND FILE MAT10.COM

XX DESCRIPTION OF SCENARIO

- 01 BERWICK BAY BRIDGE
- 02 BERWICK BAY BRIDGE NO CURRENT

- 21 DEEPWATER PORT

- 31 WILKINSON POINT
- 32 WILKINSON POINT NO CURRENT

Copy available to DTIC does not permit fully legible reproduction /

FIGURE 7 - SAMPLE INPUTS

<u>A/D INPUTS</u>
PORT PROP RPM ORDERED STBD PROP RPM ORDERED STEERING RUDDER ORDERED FLANKING RUDDER ORDERED BOW THRUSTER RPM ORDERED STOP SWITCH
<u>D/A OUTPUTS</u>
PORT PROP RPM STBD PROP RPM STEERING RUDDER ANGLE FLANKING RUDDER ANGLE BOW THRUSTER RPM RATE OF TURN HEADING ANGLE
<u>PRINTER OUTPUT</u>
TIME X,Y POSITION RPM PORT, RPM STBD, THRUSTER RPM SPEED OVER BOTTOM HEADING, TURNING RATE STEERING RUDDER, FLANKING RUDDER ANGLES SIDESLIP ANGLE RELATIVE TO BOTTOM
<u>GRAPHIC OUTPUT</u>
PLOTTER - SCENARIO, 30 SEC POSITION SCREEN - SCENARIO, 10 SEC POSITION

FIGURE 8 - COMPUTER PROGRAM INPUTS AND OUTPUTS

4.0 SIMULATOR OUTPUTS

The simulator outputs are given in Figure 8. The console outputs are numbered in Figure 5 as follows:

Port Propeller RPM	Figure 5 - 2 left
Starboard Propeller RPM	2 right
Steering Rudder Angle	5
Flanking Rudder Angle	6
Bow Thruster RPM	8
Rate of Turn	13
Heading Angle	7

Printer Output is illustrated in Figure 9.

The Berwick Bay Bridge problem is described in Figures 10 through 12. The scenario geometry and current specification scheme for this problem is illustrated in Figure 13. A series of 30 stations at Position X, Y with length R at angle α are specified, and the currents at 8 evenly spaced positions at each station are specified by velocity V_c and direction χ_c . The figure shows the positions of the 30 stations. The current values and directions are as given in Volume II, in the listing of DTN10.

Graphic Output is illustrated in Figures 14 through 16. The only difference between the plotter and screen output is the frequency of boat position, as selected by the program.

01-BERWICK BAY BRIDGE DOWNRIVER (2 X T)

SAMPLE RUN NUMBER 2

30-MAR-79

TIME(H.M.S)	X	Y	RPM F	RPM S	SPEED	HEADING	RATE RUDDER	SETTINGS	BETA	TRPM
0. 0. 0	14355.	3300.	100.00	100.00	7.00	216.00	0.000	0.0	0.0	0.0000
0. 0. 20	14158.	3156.	130.47	130.37	7.39	215.44	-0.050	5.2	0.1	359.29
0. 0. 40	13951.	3006.	130.57	130.47	7.73	214.09	-0.082	5.9	0.1	358.55
0. 1. 0	13734.	2852.	130.57	130.27	8.01	212.17	-0.110	7.6	0.1	357.79
0. 1. 20	13507.	2696.	130.47	130.37	8.26	209.87	-0.120	5.9	0.1	357.22
0. 1. 40	13271.	2542.	130.47	130.37	8.46	207.39	-0.127	5.9	0.1	356.73
0. 2. 0	13025.	2391.	130.47	130.37	8.61	204.76	-0.131	3.7	0.1	353.97
0. 2. 20	12770.	2246.	130.57	130.47	8.71	202.31	-0.117	3.7	0.1	355.80
0. 2. 40	12509.	2108.	130.57	130.37	8.78	200.00	-0.115	3.7	0.1	353.41
0. 3. 0	12241.	1978.	130.57	130.37	8.83	197.71	-0.113	2.6	0.1	355.46
0. 3. 20	11968.	1857.	130.57	130.47	8.87	195.46	-0.111	2.5	0.1	354.86
0. 3. 40	11689.	1746.	130.57	130.47	8.89	193.41	-0.092	0.4	0.1	354.04
0. 4. 0	11406.	1646.	130.57	130.37	8.87	191.05	-0.153	8.1	0.1	353.63
0. 4. 20	11120.	1559.	130.47	130.47	8.82	187.52	-0.194	8.1	0.1	352.64
0. 4. 40	10832.	1488.	130.57	130.47	8.73	183.08	-0.248	12.1	0.1	352.00
0. 5. 0	10543.	1437.	130.57	130.37	8.62	177.61	-0.305	16.7	0.2	350.73
0. 5. 20	10254.	1410.	130.47	130.37	8.58	172.81	-0.181	0.7	0.1	350.55
0. 5. 40	9964.	1405.	130.57	130.47	8.60	169.64	-0.160	6.0	0.1	351.68
0. 6. 0	9674.	1417.	130.57	130.47	8.61	166.30	-0.176	8.7	0.1	351.83
0. 6. 20	9385.	1446.	130.57	130.27	8.60	162.42	-0.206	8.7	0.1	350.96
0. 6. 40	9098.	1494.	130.57	130.47	8.58	157.86	-0.249	12.1	0.1	350.79
0. 7. 0	8817.	1560.	130.57	130.47	8.55	152.74	-0.260	12.2	0.1	351.04
0. 7. 20	8542.	1648.	130.57	130.47	8.56	148.14	-0.176	0.5	0.1	350.49
0. 7. 40	8272.	1755.	130.57	130.47	8.62	145.30	-0.119	0.5	0.1	352.57
0. 8. 0	8007.	1878.	130.47	130.37	8.71	143.19	-0.099	0.5	0.1	351.83
0. 8. 20	7744.	2016.	130.57	130.47	8.83	141.62	-0.042	-5.7	0.1	351.67
0. 8. 40	7485.	2168.	130.57	130.47	8.99	141.54	0.037	-9.7	0.1	354.68
0. 9. 0	7224.	2331.	130.57	130.37	9.18	143.08	0.108	-9.7	0.1	356.43
0. 9. 20	6960.	2499.	130.57	130.37	9.36	145.73	0.152	-9.7	0.1	358.82
0. 9. 40	6688.	2667.	130.57	130.47	9.52	148.79	0.139	-2.0	0.1	0.28
0.10. 0	6409.	2831.	130.57	130.47	9.66	150.88	0.088	-2.0	0.1	0.80
0.10. 20	6124.	2993.	130.57	130.47	9.77	152.41	0.069	-2.0	0.1	1.10
0.10. 40	5833.	3153.	130.47	130.37	9.86	153.70	0.061	-1.9	0.1	1.29

FIGURE 9 - PRINTER OUTPUT

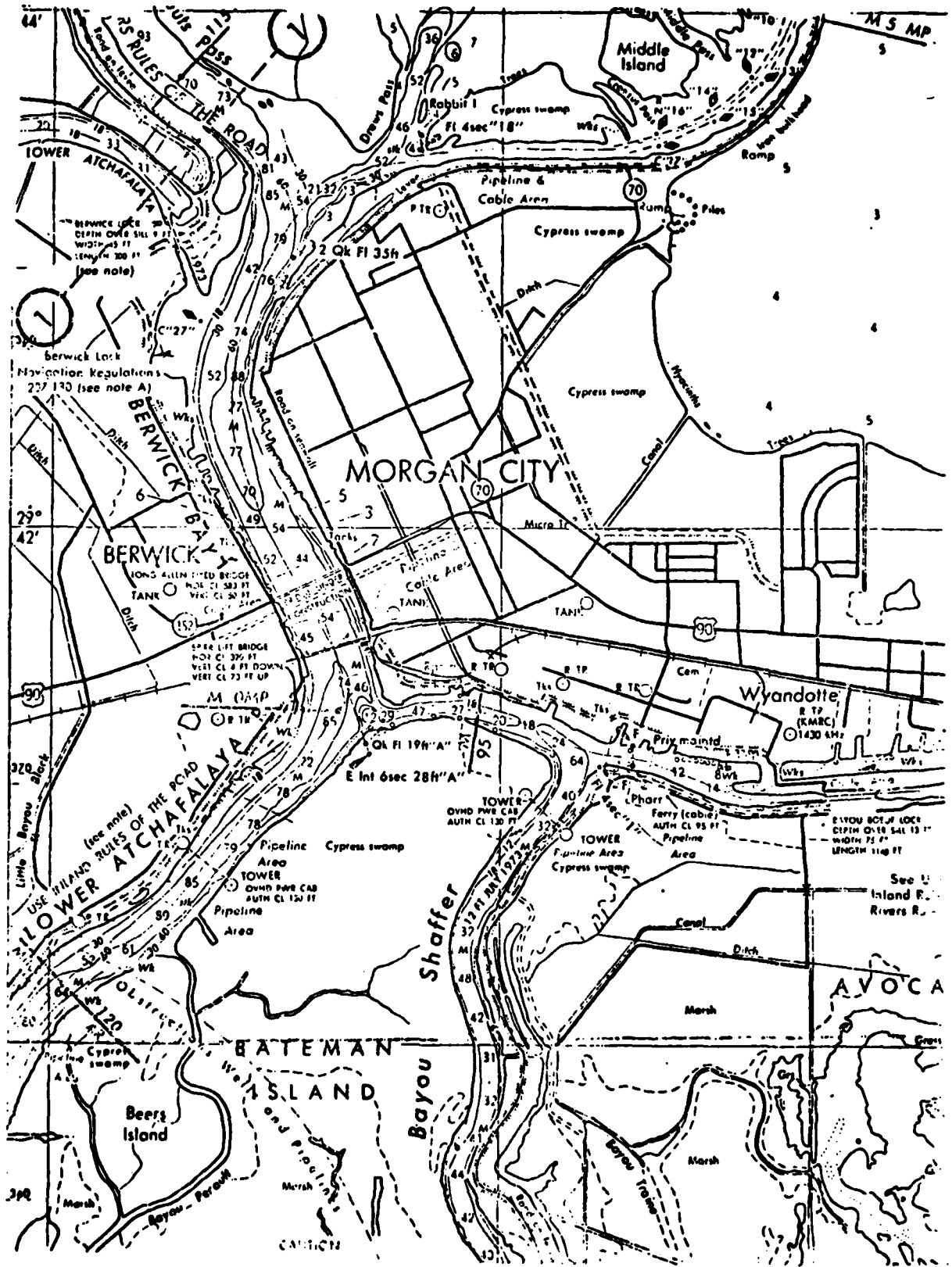

copy available to DTIC does not
warrant fully legible reproduction

FIGURE 10 - BERWICK BAY, LOUISIANA CHART

Downstream Operation

- Entering Berwick Bay from the Port Allen route hold the sailing line shown and reduce speed to about half ahead.
- Entering Berwick Bay from Stouts Pass cross the river between ⑤ and ⑥ and favor left descending shore.
- Generally hold slow speed between ④ and ③ with intermittent use of power to stay on course and close to shore.
- At ③ current will set tow toward right descending shore if out too far in river.
- Cut point at Conrad Shipyard ③ in close to prevent current from catching stern of tow and rotating it out toward mid-river.
- Run between slow and half speed at ③ to maintain steerage and control.
- Should be shaped up by ②. Current tends to get tow out-of-shape between ② and ③.
- At ① either drive or hold half speed depending on conditions.
- Enter highway bridge at mid span or just to the right of mid span depending on current conditions.
- Current will shift at highway bridge and operator must expect a strong left hand draft between bridges.
- Favor right descending pier of railroad bridge to offset current and to prepare for sharp right hand bend in river just below bridge.
- Under some conditions with a long tow you must back and flank as soon as you clear the railroad bridge in order to line up for the passage down river.

Upriver

- In general operator can hold middle of river during upstream approach.
- At ② slow down and line up with railroad bridge.
- Favor Berwick pier (left ascending pier) to offset current just below and between bridges.

FIGURE 11 - OPERATOR STRATEGY

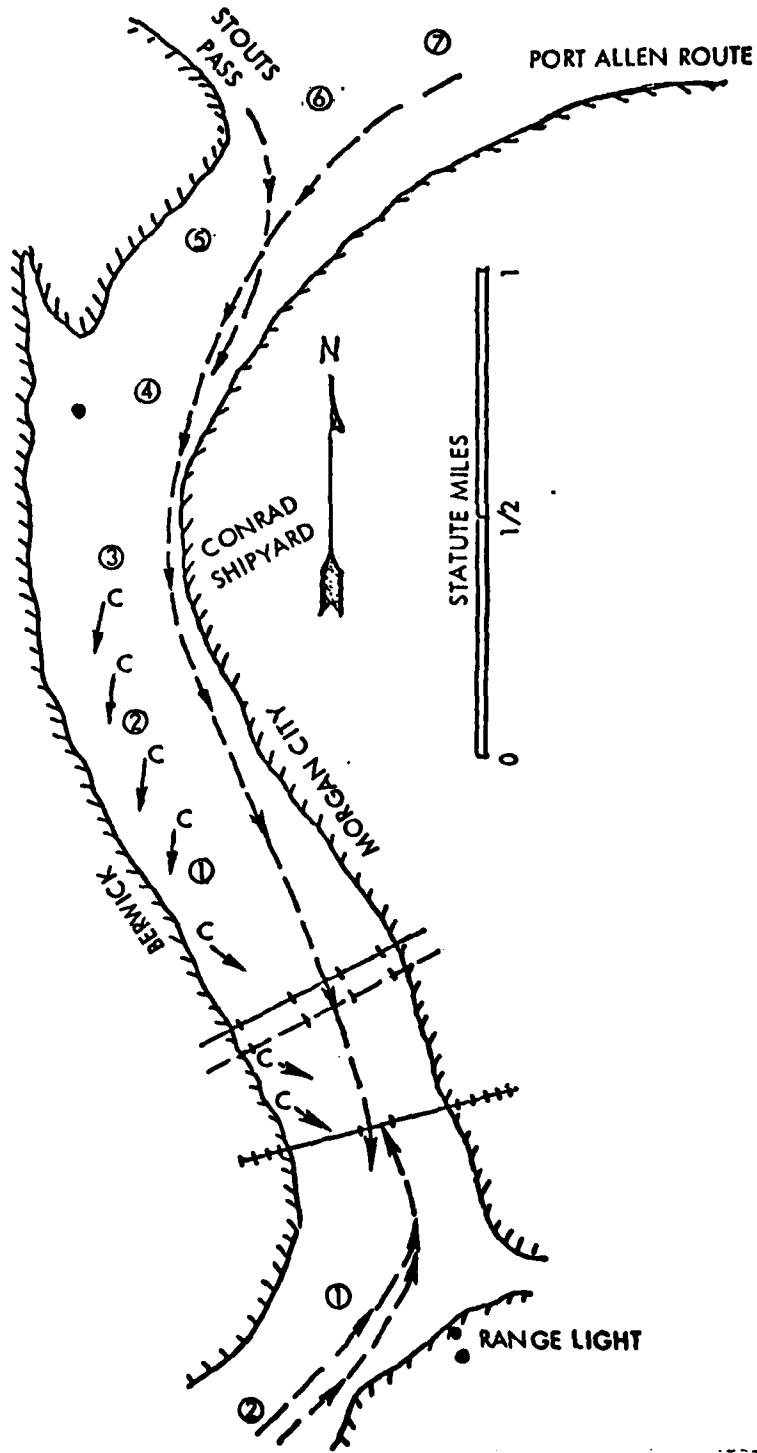

FIGURE 12 - BERWICK BAY PASSAGE

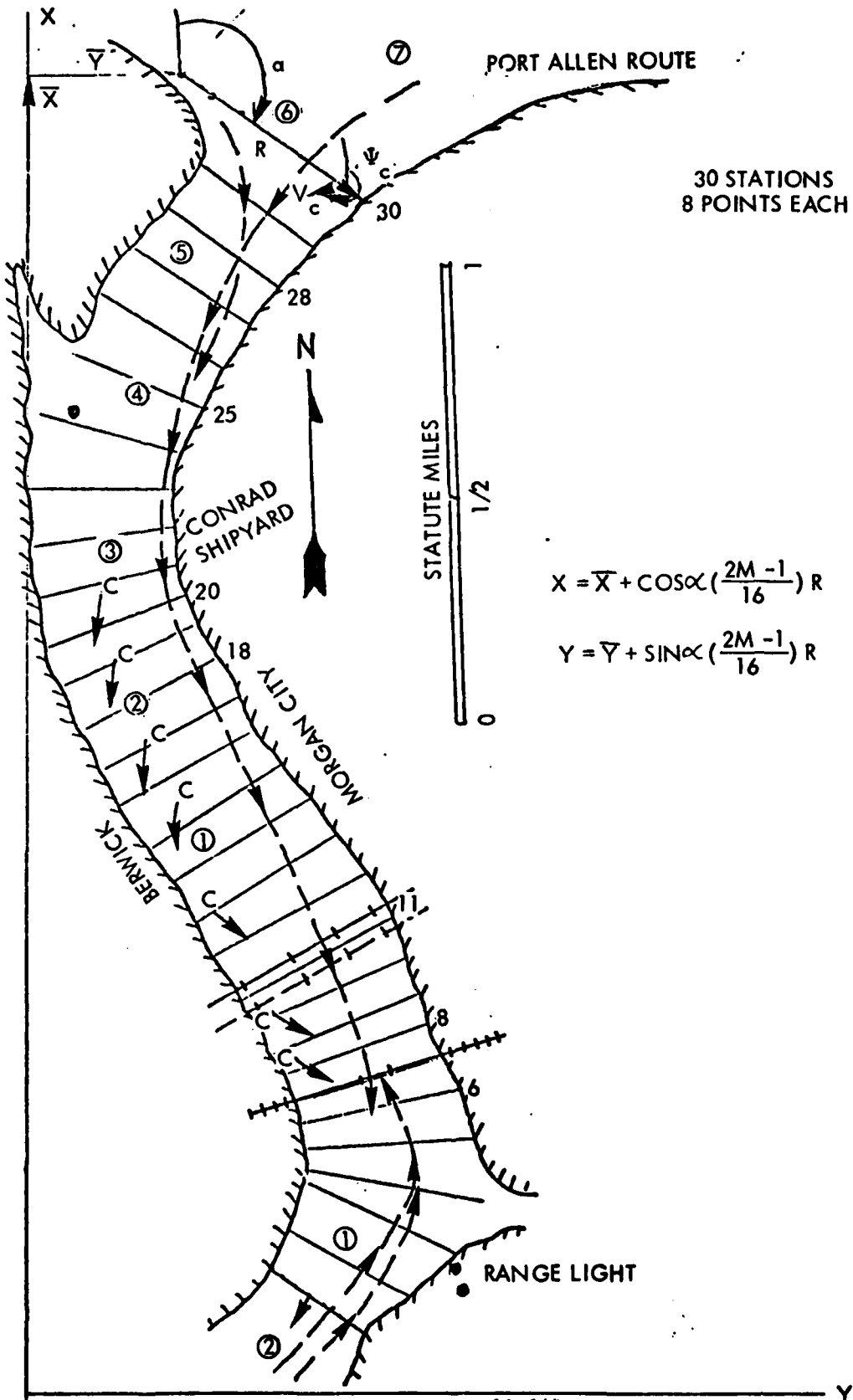

FIGURE 13 - CURRENT MAP

05-BERWICK BAY BRIDGE DOWNRIVER (NO CUR) SAMPLE RUN NUMBER 3 30-MAR-78

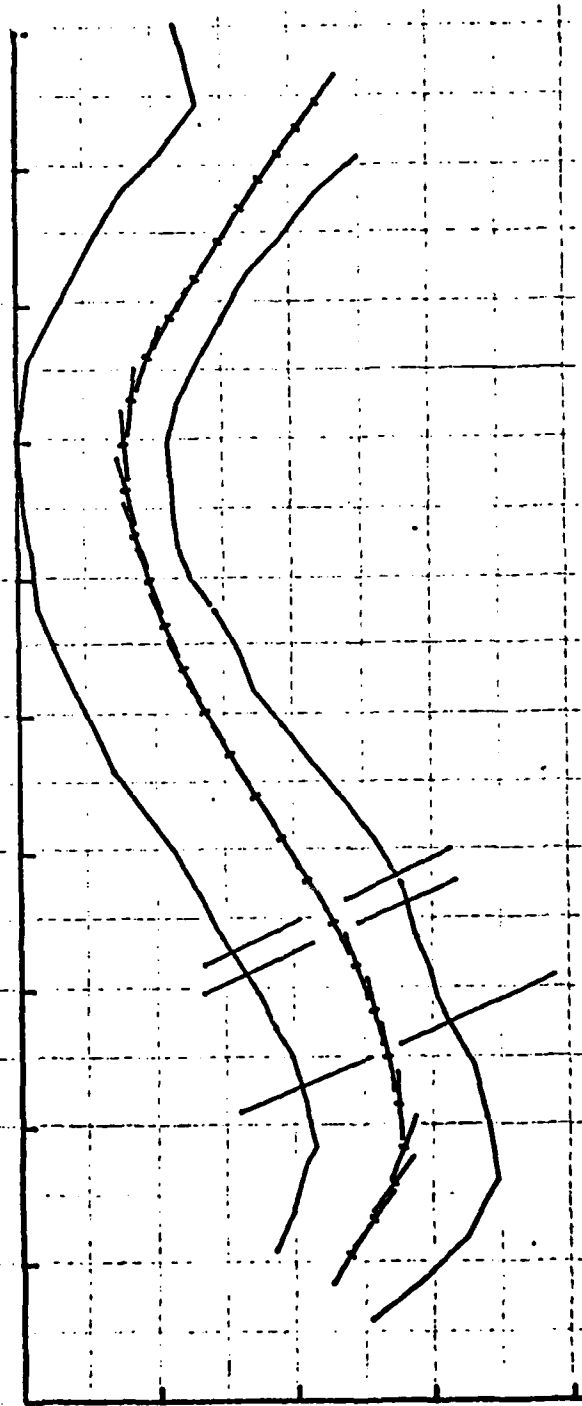

FIGURE 14 - NO CURRENT

02-BERWICK BAY BRIDGE DOWNRIVER SAMPLE RUN NUMBER 1 30-MAR-79

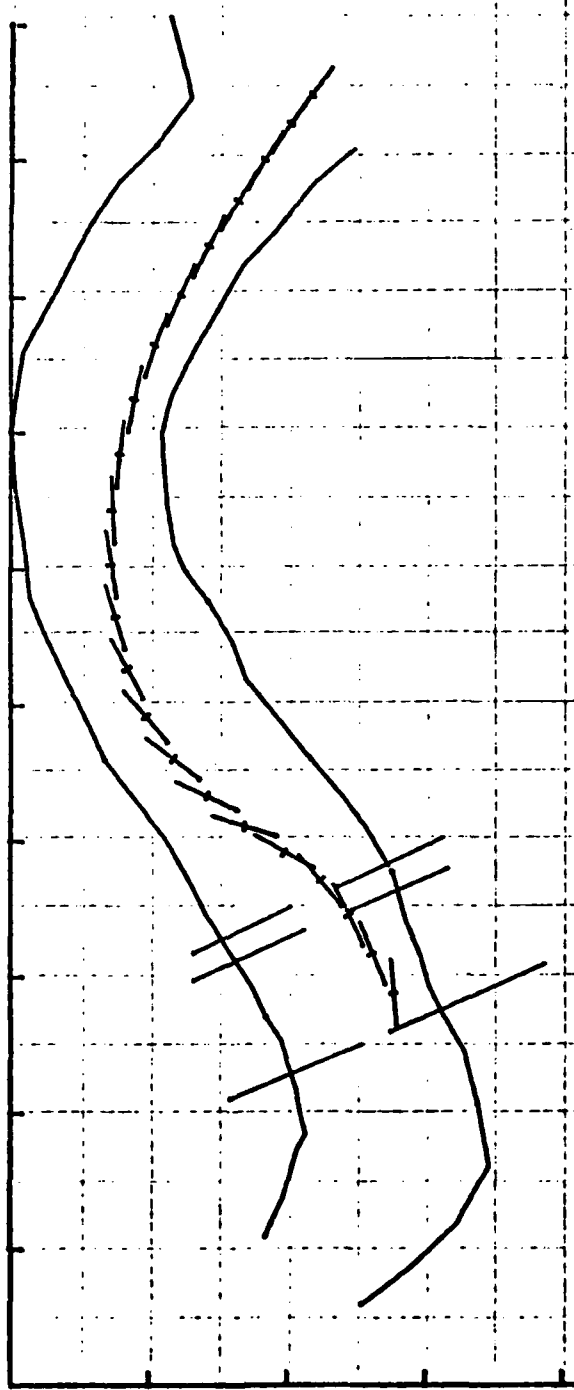

FIGURE 15 - EFFECTS OF UPSTREAM AND BRIDGE CURRENTS

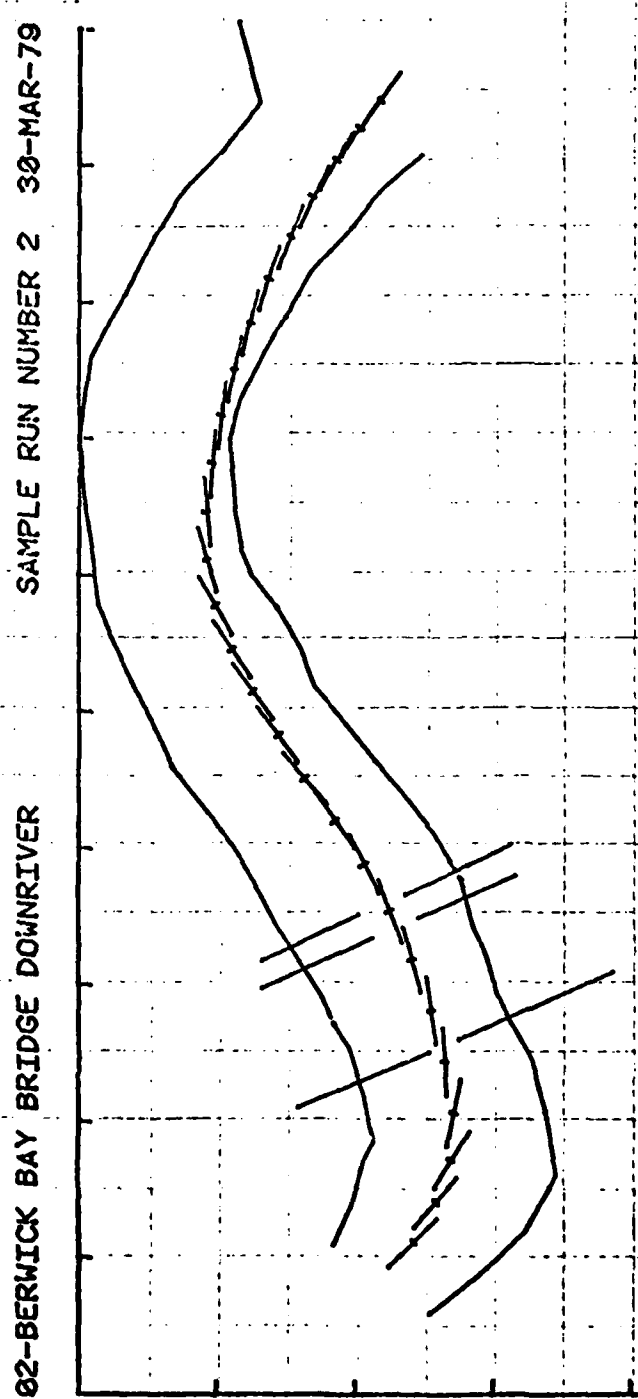

FIGURE 16- EFFECTS OF UPSTREAM AND BRIDGE CURRENTS

HYDRONAUTICS, Incorporated

-21-

5.0 CONSOLE CONNECTIONS

HYDRONAUTICS, Incorporated

-22-

A/D DEFINITIONS

0 - 15 Channels \pm 5V

- 1 - WIRE A - Port Propeller RPM
- 2 - WIRE E - Starboard Propeller RPM
- 3 - WIRE B - Steering Rudders
- 5 - WIRE C - Flanking Rudders
- 7 - WIRE D - Thruster RPM
- 8 - WIRE F - Stop Switch

HYDRONAUTICS, Incorporated

-23-

D/A DEFINITIONS

0 - 7 Channels $\pm 5V$

- 0 - WIRE J - Port Propeller RPM
- 1 - WIRE K - Starboard Propeller RPM
- 2 - WIRE L - Steering Rudder Angle
- 3 - WIRE M - Flanking Rudder Angle
- 4 - WIRE N - Thruster RPM
- 5 - WIRE P - Rate of Turn
- 6 - WIRE R - Heading
- 7 - WIRE S -

HYDRONAUTICS, Incorporated

-24-

6.0 SIMULATOR OPERATION

HYDRONAUTICS, Incorporated

-25-

RUNNING THE SIMULATOR

TURN ON

DEC PDP 11/34
DEC WRITER (300 BAUD, LINE, AUTO LF)
PLOTTER (LOAD)
4014 TERMINAL (RESET PAGE ON GLOW)
CONSOLE - SERVO RESET ON, RUN ON
TURN ON DISK 0

COLD START

CTRL/HLT, CTRL/BOOT TYPE:DL }
@ STARTG }

SCREEN

TYPE: DATE — 10-May-79 }
TIME — 20:30:15 }
RUN — MAT10 }

FOLLOW INSTRUCTIONS

ENTER OPERATOR I.D. UP TO 20 CHARACTERS
MOVE DEC WRITER TO NEW PAGE
LOAD PLOTTER, REMOVE COVER AND SET PEN (780 x 1170 GRID)
CONSOLE SERVO OFF, RUN ON
RESET SCREEN
} ON 4014

STOPPING

RUN OFF ON CONSOLE (STOP ON SCREEN)
TURN RUN ON AGAIN

HYDRONAUTICS, Incorporated

-26-

CHANGING THE PROBLEM

COPY — DTSXX.FOR — DTN10.FOR (XX = PROBLEM NUMBER)
FORTRAN — DTN10)
@ MAT10)

TURNING OFF

DISK 0 OFF (LOAD)
PLOTTER LOAD, PEN COVER ON
SERVO ON, RUN ON, CONSOLE OFF (AFTER HEADING = 0)
TEKTRONIX 4014 OFF
PLOTTER OFF
DEC WRITER OFF
DEC 11/34 OFF

HYDRONAUTICS, Incorporated

-27-

7.0 WIRING DIAGRAMS

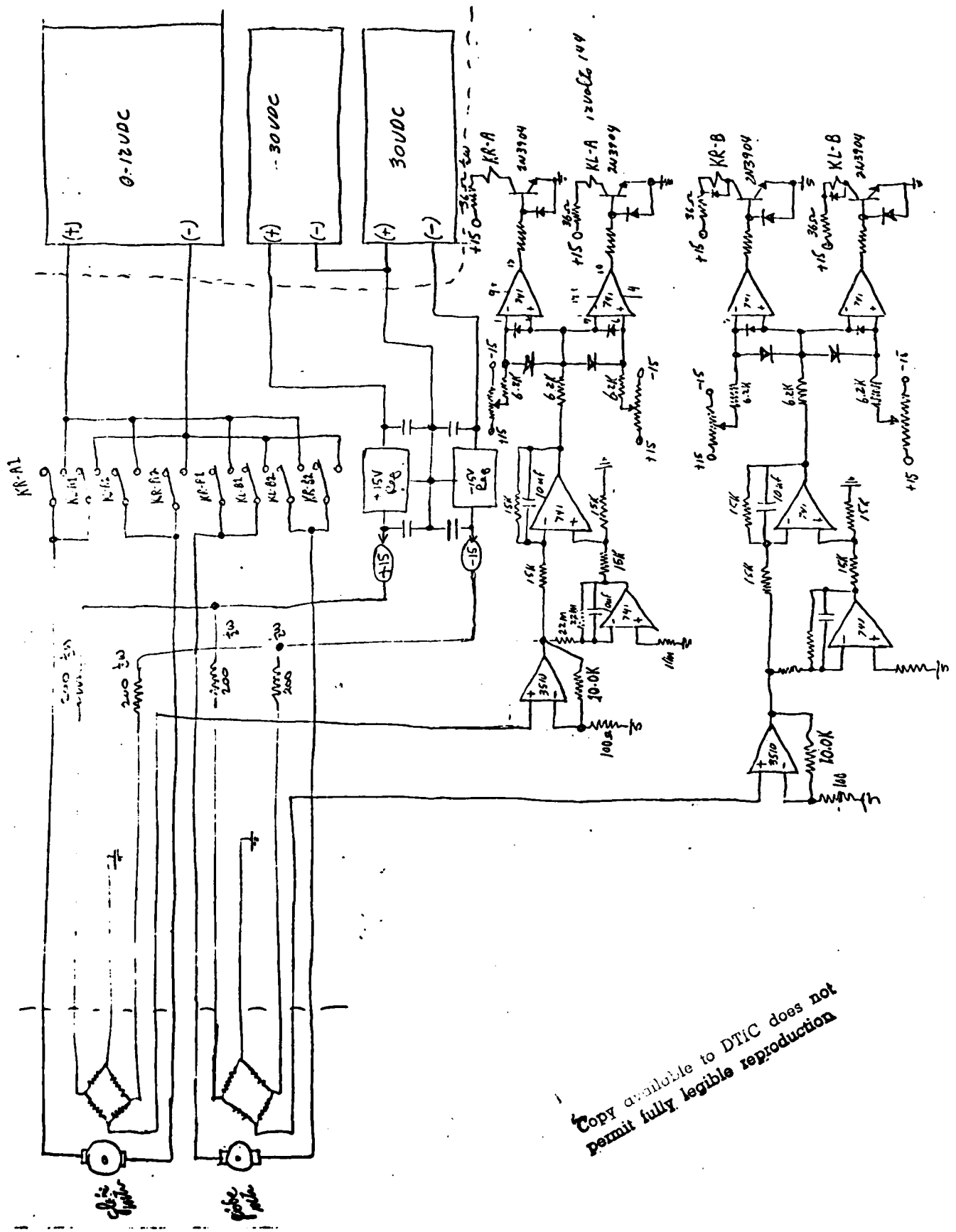

Copy available to DTIC does not permit fully legible reproduction

8.0 SCENARIO PARAMETERS

Many of the variables in the input routines which are used to establish the operating geometry are described here in detail.

Subroutine DTL10 - Initial Conditions

XS, YS - Initial towboat position. XS is the horizontal co-ordinate in scene units, positive to the right, which is also the North direction of the scene. YS is the vertical co-ordinate in scene units, positive downward, which is the East direction.

PSID - Initial towboat orientation, with 0 being the North direction (headed to the right), 90 being East (headed down), etc.

NCCS - Number of current (and also scene) station to check first in current determination subroutine. Usually 1 or NCCT if boat starts at either end of the scene.

Subroutine DTM10 - Towboat Parameters

No scene parameters

Subroutine DTN10 - Scene Parameters

NCCT - Number of current/scene stations

SCALF - Scale factor used to allow current and scene parameters to be entered in other than scene units. The values of XX, YY, and RR used to set the scene are multiplied by SCALF in Subroutine SUB11 to change them to scene units for storage in the XW and YW arrays.

XX - Horizontal co-ordinate of a station starting point. Positive to the right. Units compatible with scene using SCALF.

YY - Vertical co-ordinate of a station starting point. Positive downward. Units compatible with scene using SCALF.

RR - Radial co-ordinate of station. The scene boundary is at the ends of the RR line. One end is at XX, YY, and other at the end of RR. Units compatible with scene using SCALF.

PP - Orientation of RR with respect to XX, YY point, in degrees. PP equal to 270 implies that RR is in an upward vertical direction, so that the scene boundary is at XX, YY and XX, YY-RR. The end points of the NCCT stations are connected to form the scene boundary.

VC, PSIC - Current values in ft/sec and direction in degrees.
VC(1) to VC(8) are the eight values at Station 1
VC(9) to CV (16) at Station 2, etc.

NPPB - Number of straight line segments (up to 10) drawn on scene. Co-ordinates are in scene units; SCALF is not used to change them. XB(1), YB(1) is the starting point of line 1, XB(2), YB(2) is the end of this line.

NPPT - Number of positions plotted on graphic output device for every 1 plot of towboat position on plotter.

NCCS - If NCCS is set to -2, no current is assumed by the current subroutine CURT. This saves time by not requiring CURT to search for the current values at each calculation interval.

DATE
ILMEI
— 8