

MICROCOPY RESOLUTION TEST CHART

NATIONAL BUREAU OF STANDARDS-1963-A

12

AD

Report 2351

BITUMINOUS EQUIPMENT SYSTEMS

by
Andrew C. Tinsman

March 1982

REC'D
JUN 30 1982

A

Approved for public release; distribution unlimited.

U.S. ARMY MOBILITY EQUIPMENT
RESEARCH AND DEVELOPMENT COMMAND
FORT BELVOIR, VIRGINIA

82 06 30 021

DTC FILE COPY AD A116254



UNCLASSIFIED

SECURITY CLASSIFICATION OF THIS PAGE (When Data Entered)

REPORT DOCUMENTATION PAGE		READ INSTRUCTIONS BEFORE COMPLETING FORM
1. REPORT NUMBER 2351	2. GOVT ACCESSION NO. AD-A116 254	3. RECIPIENT'S CATALOG NUMBER
4. TITLE (and Subtitle) BITUMINOUS EQUIPMENT SYSTEMS		5. TYPE OF REPORT & PERIOD COVERED
7. AUTHOR(s) Andrew C. Tinsman		6. PERFORMING ORG. REPORT NUMBER
9. PERFORMING ORGANIZATION NAME AND ADDRESS U.S. Army Mobility Equipment Research and Development Command; DRDME-HKP Fort Belvoir, Virginia 22060		8. CONTRACT OR GRANT NUMBER(s)
11. CONTROLLING OFFICE NAME AND ADDRESS Commander; U.S. Army Mobility Equipment Research and Development Command; Fort Belvoir, Virginia 22060		10. PROGRAM ELEMENT, PROJECT, TASK AREA & WORK UNIT NUMBERS
14. MONITORING AGENCY NAME & ADDRESS (if different from Controlling Office)		12. REPORT DATE March 1982
		13. NUMBER OF PAGES 37
		15. SECURITY CLASS. (of this report) Unclassified
		15a. DECLASSIFICATION/DOWNGRADING SCHEDULE
16. DISTRIBUTION STATEMENT (of this Report) Approved for public release; distribution unlimited.		
17. DISTRIBUTION STATEMENT (of the abstract entered in Block 20, if different from Report)		
18. SUPPLEMENTARY NOTES		
19. KEY WORDS (Continue on reverse side if necessary and identify by block number) Bituminous Mixing Operations Automatic Grade Control Asphalt Mix Plant Storage Tank Compaction Equipment Raw Aggregate Hot Oil Heater Surface Treatments Drum Mix Distributions Weigh Batch Plant Paving Operations		
20. ABSTRACT (Continue on reverse side if necessary and identify by block number) This report presents a general summary of Asphalt Paving Operations covering both past and present equipment and ideas. Also, considerations are presented regarding those ideas and equipment which will meet the needs of the Military and stay abreast of the "state-of-the-art."		

DD FORM 1 JAN 73 1473

EDITION OF 1 NOV 65 IS OBSOLETE

UNCLASSIFIED

SECURITY CLASSIFICATION OF THIS PAGE (When Data Entered)

SUMMARY

This report does not cover the entire spectrum of the Industry's paving equipment or capabilities. The areas of discussion were only those that parallel the present Military interests and capabilities.

In order for the state-of-the-art and the equipment to be brought up to date, the Military should review its needs and determine its asphalt construction capability requirements; then, specific recommendations can be finalized.



Accession For

DTIC COPY

INSPECTED

2

A

PREFACE

Information received from Barber-Greene Company, E.D. Etnyre and Company, Iowa Manufacturing Company, and Portec, Incorporated, Pioneer Division was used in this report.

CONTENTS

Section	Title	Page
	SUMMMARY	iii
	PREFACE	iv
	ILLUSTRATIONS	vi
I	INTRODUCTION	1
	1. Scope	
II	MAJOR FUNCTIONS IN ASPHALT PAVING OPERATIONS	
	2. Material Flow	1
	3. Raw Aggregate Materials	1
	4. Asphaltic Materials	2
	5. Asphalt Mixing Plants	6
	6. Types of Plants	9
	7. Plant Support Equipment	14
	8. Electric Plant Operation	16
	9. Paving Operations	17
	10. Compaction	20
	11. Surface Treatments	21

ILLUSTRATIONS

Figure	Title	Page
1	Crushing and Screening Plant, 75-Ton/h	3
2	Washing, Crushing, and Screening Plant, 75-Ton/h	4
3	Asphalt Melter, De-Drumming Operation	5
4	150-Ton/h Asphalt Mixing Plant	7
5	Continuous-Mix Plant—Schematic Operation	10
6	Weigh Batch Plant—Schematic Operation	10
7	Drum Mix Process	11
8	Heater/Storage Tank	15
9	Finishing Machine, Bituminous Material	18
10	Automatic Grade Control	18
11	Self-Propelled Spreader, Aggregate	23
12	Mechanical Towed Spreader, Aggregate	23
13	Distributor Dust Control Material	25

BITUMINOUS EQUIPMENT SYSTEMS

I. INTRODUCTION

1. **Scope.** In the last decade, the general field of Asphalt Paving Operations has changed and grown with new equipment, concepts, and practices. Unfortunately, over the same period, some methods of operation have been retained both within the Military and within the Contracting Industry because of materials, equipment costs, and the availability of equipment and trained personnel.

II. MAJOR FUNCTIONS IN ASPHALT PAVING OPERATIONS

2. **Material Flow.** The process of mixing and laying asphalt concrete is a rather complex logistical problem—both in the equipment required and the materials handled. A good way to separate the major functions in the overall operation is to consider the material flow from the raw materials to the finished material in the pavement. With this approach we can point to some of the shortcomings (or ill defined responsibilities) in today's Military operations. Briefly, these functions are:

- Obtaining raw aggregate materials (wet stone and sand) at the plant site.
- Obtaining hot, pumpable bituminous cement (liquid asphalt) at the asphalt plant site.
- Heating—Drying—Proportioning—Mixing of the above items at the plant site and loading the finished material into trucks.
- Transporting the hot asphalt mix to the laying operation in dump trucks.
- Laying and rolling the asphalt mix.

A discussion on each of the above functions follows, giving limitations of today's operations and methods for more efficient operations in the future.

3. **Raw Aggregate Materials.** The raw aggregate materials commonly used in a bituminous concrete plant are:

- Crushed stone.
- Crushed gravel.

- Natural sand and/or natural sand and gravel.
- Washed sand and/or washed sand and gravel.
- Filler Materials (lime stone, dust, cement, etc.).

Crushed stone and crushed gravel are products of a rock-crushing plant. Washed sand can also be a product of a crushing, screening, and washing operation (or a separate washing operation). These crushed or washed materials can be referred to as *processed materials*. Natural sands are those local sands which can be used as a portion of a mix without any special pretreatment and can be loaded out of sand pits or dredged from streams.

Today, the processed materials are obtained from a stone quarry or gravel pit source and are produced by an Engineer unit operating either a 75-ton/h washing, crushing, and screening plant (Figure 1). Unfortunately, these plants are, today, required to furnish several types and several different sizes of material for different end uses. For instance, such a plant may have to furnish base stone in large sizes, concrete aggregates for a concrete plant, and asphalt plant aggregates. This triple requirement not only limits the availability of any one size but creates inefficiency in operation due to switching back and forth between sizes.

The natural materials, sand and gravel, are produced either from a material company or by the personnel operating the 75-ton/h washing and screening plant (Figure 2). The filler materials (if needed) are usually brought from depot stock in bags and introduced separately to the mixing operation through special equipment.

4. Asphaltic Materials. Today practically 100 percent of the asphaltic material used in a hot-mix bituminous concrete plant is an asphalt cement, hard as a rock at ambient temperatures. Present logistical systems deliver this material to the asphalt mixing plant site in 55-gal drums (Figure 3). Through use of a *melting sump* in combination with a hot oil, heat exchange unit, the asphalt is heated, dropped from the barrel to a sump (tank), and then completely liquified at approximately 200°F in the sump. It is then pumped to storage tanks and heated to and maintained at 300°F for use in the mixing plant.

The difficulties and hazards of shipping, transporting, and melting of asphalt in steel barrels results in actual use of only 65 to 70 percent of the asphalt cement in the end product. The melting sumps (asphalt melters) available today will melt only 12 drums at a time with a total capacity of 750 gal/h. A modern plant at 200 tons/h production would require approximately 2500 to 3000 gal/h of asphalt cement. At this rate, it would require two melters operating approximately 20 h/d to produce enough asphalt to carry one plant for 10 h of operation. This would require that 500 to 600 drums daily be transported to the plant, opened, and processed by the melter and the empty drums stock piled somewhere out of the way of the plant operations. In addition, all these operations are



Figure 1. Crushing and screening plant, 75-ton/h.



Figure 2. Washing, crushing, and screening plant, 75-ton/h.

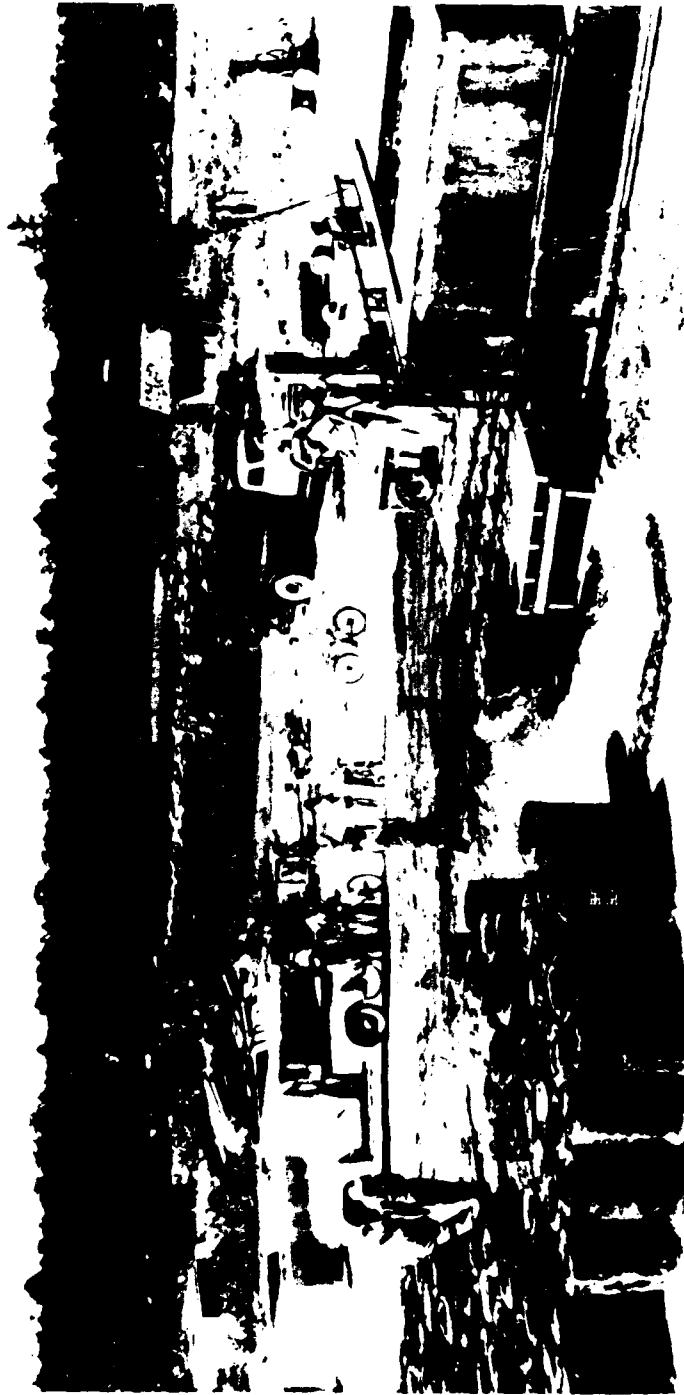

Figure 3. Asphalt melter, de-drumming operation.

strictly manual and are done under hot, dirty, dark, dusty, and dangerous conditions. It appears there must be a better way to accomplish this job and assure an adequate supply of hot, pumpable asphalt to a plant without having a large portion of the crew operating 20 to 24 h/d.

The Military should give strong consideration to an operation more similar to that of a commercial operator having hot asphalt supplied by trailer truck to the plant. To accomplish this, an asphalt depot with a tank farm, high-capacity melting equipment, and trailer truck loading facilities would have to be established with a capability of servicing an asphalt plant with hot asphalt during a major paving operation. Since a high-capacity asphalt depot is not available, a design study to develop such a facility and determine who should install, staff, and operate it would have to be undertaken.

The above is based upon the requirement to construct a major airfield or landing strips and primary roads for nation building requiring high daily production over a long period of time.

Such a facility would hinder mobility and not be required for early phases of operations.

5. **Asphalt Mixing Plants.** Since the proportioning, combining, and mixing of the ingredients for an asphalt mix require a somewhat complex mixing plant, it is necessary at this point to review the basic units in the 100- to 150-ton/h asphalt mixing plant as used by the Military today. A listing of components, a brief description of their functions, and references to the sketch in Figure 4 follow:

Reference Unit on Schematic Sketch	Function
1. Cold Feed Bins (4 Compartments)	Proportions the cold and wet cold feed aggregates.
2. Cold Aggregate Conveyor	Elevates combined sand and stone to drying and heating unit.
3. Rotary Dryer (with oil burner).	Dries initial surface moisture (2 to 7 percent) from aggregates to less than ½ percent. Raises aggregate temperature to 300°F.
4. Fines Collector and Fan	Provides air for combustion and moisture carry-out from drying unit. Also collects fines materials trapped in draft and returns a high percentage of them to the mix.

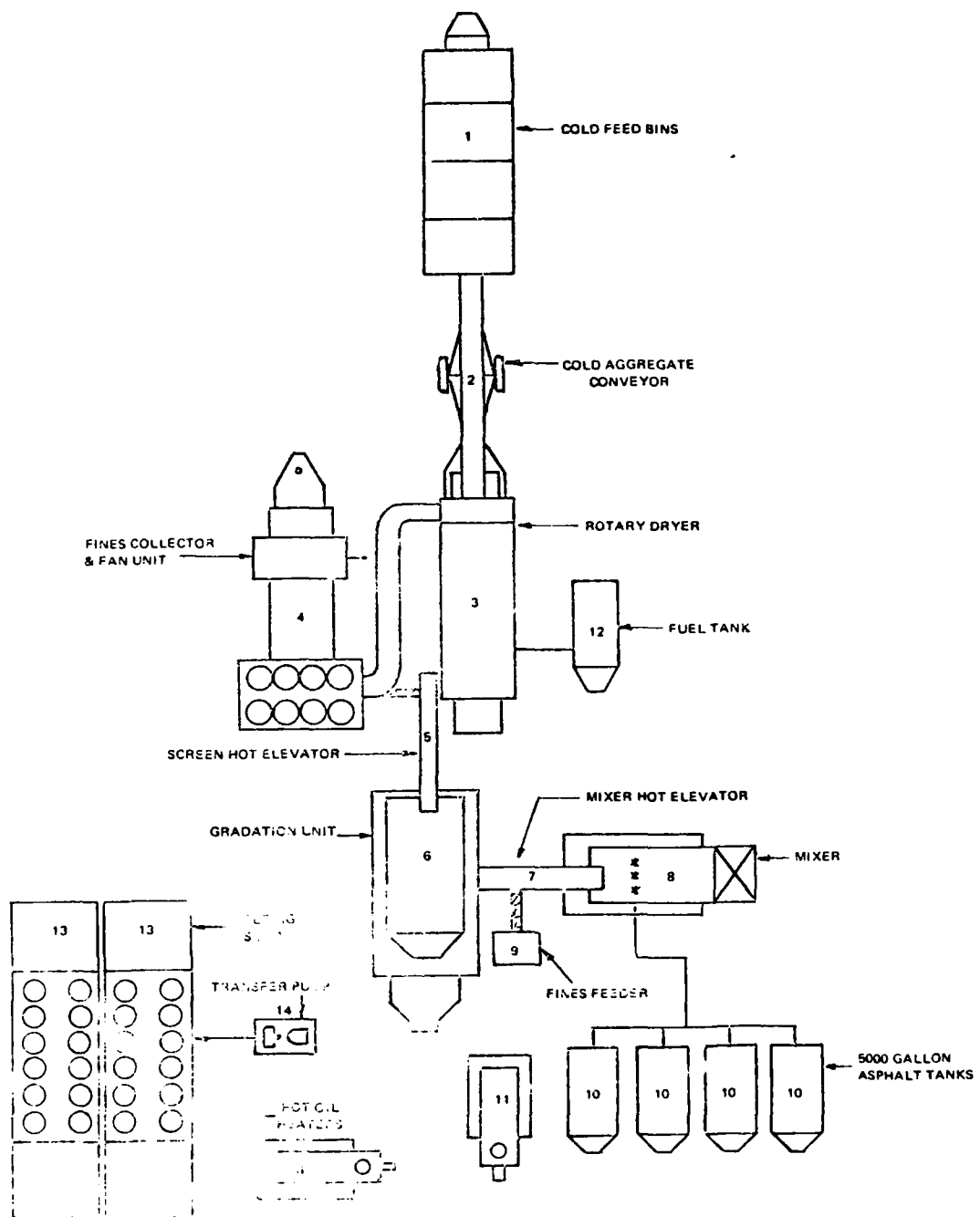

Figure 4. 150-ton/h asphalt mixing plant.

5. **Screen Hot Elevator** Elevates hot-dry aggregates and fines to gradation unit.
6. **Gradation Unit (consists of screen, surge bin and proportioning unit)** Separates dry aggregates into 2, 3, or 4 sizes as required by mix specifications; provides surge storage and repropotions hot-dry aggregates to mix specifications.
7. **Mixer Hot Elevator** Elevates proportioned hot-dry aggregates to mixer pugmill. Also, receives additional fines material if required.
8. **Mixer (Pugmill)** Mixing unit meters hot asphalt, mixes it with aggregates, and loads finished mix into trucks.
9. **Fines Feeder** If aggregate material is short of fine material, additional dry fines (bagged) are added at this point.
10. **Four 5000-Gal Asphalt Tanks** Hot asphalt cement (300°F) stored in these tanks ready for use in mixer. Tanks are filled from melting sumps.
11. **Hot Oil Heater** Hot oil heat exchange unit circulates heating oil to asphalt tanks, pipe lines, and mixer pugmill to maintain 300°F temperature of asphalt cement and asphalt mix. Also, hot oil heater supplies heat for melting barreled asphalt in the melting sump.
12. **Fuel Tank** Contains fuel oil for dryer burner operation.
13. **Melting Sumps (two units)** The asphalt melting sumps melt the hot asphalt out of the barrels and brings it up to 200 to 250° F temperature so it can be pumped over to the tanks with the asphalt plant.
14. **Transfer Pump** Transfer pump is used to pump asphalt materials from the tank under the melting sump to the 5,000-gal tanks.

6. Types of Plants. In general, three basic types of plants are used commercially today. They are the Continuous Mix (Figure 5), Weigh Batch (Figure 6), and the Drum Mix (Figure 7) design type plants.

Since both the Continuous Mix and the Weigh Batch plants have been used commercially for decades, we should review the basic fundamental differences in the principles of the two designs.

In both type plants (see Figure 4), the operation is similar from the cold feed bins (1) through the screening unit into the surge bins where one to four sizes of hot dry aggregates are held for proportioning. In place of the Gradation Unit (6), Hot Elevator (7), and Mixer Unit (8) of the Continuous Type Plant, the Batch Plant (or Tower Plant) consists of a screen unit, surge bins, weigh hopper, pugmill mixing unit, and supporting legs in a tower assembly using gravity flow (interrupted by gates) from the screen down through the pugmill to the trucks. The two major differences in operation of these plants are in the method of proportioning the mix ingredients and the mixing process in the pugmill. Comparing these differences side by side, by means of schematic sketch, shows the material flow in the two systems.

a. Material Proportioning.

(1) **Continuous Mix Plant.** Aggregate material is continuously and simultaneously drawn from 1 to 4 hot bins by continuous apron feeders with adjustable gates set to deliver the correct percentages of each material. This material is then elevated to the mixer unit where a metering pump sprays it with the set percentage of asphalt cement.

(2) **Weigh Batch Plant.** Aggregate materials are drawn individually and sequentially from surge bins into a weighing hopper. From 1 to 4 materials are weighed for each batch. Meanwhile the correct amount of asphalt cement is weighed in a separate container. The aggregate batch is then dumped into the pugmill slightly mixed and the asphalt cement is dumped or sprayed on the aggregate. The normal cycle time per batch is 45 s to 1 min.

b. Mixing Operation.

(1) **Continuous Mix Plant.** The aggregate and asphalt materials are fed continuously into a pugmill mixer. The mixer conveys and mixes the materials, pressure mixing them against retarding paddles and a dam gate at the discharge end of the pugmill. The mixed material flows over the dam gate and into the haul unit. The mixing time is controlled by the depth of material in the pugmill and in normal operation mixing time can be increased without loss of capacity.

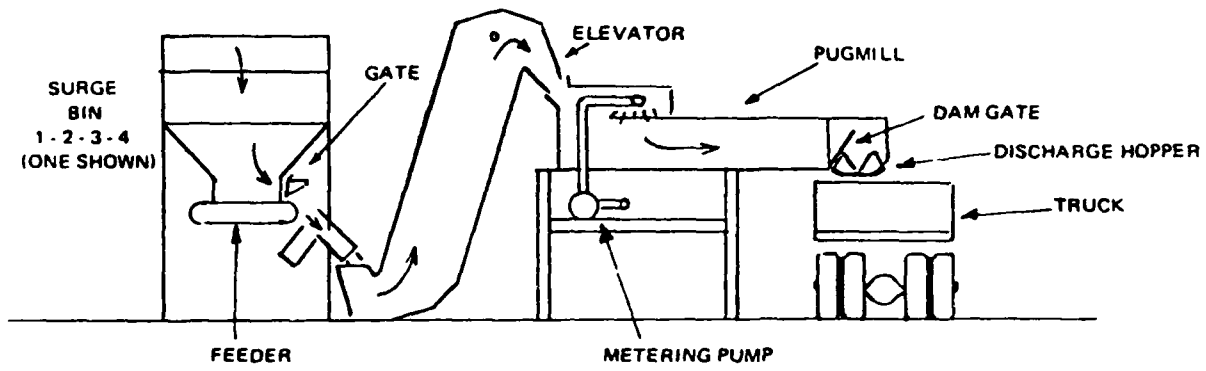

Figure 5. Continuous-mix plant—schematic operation.

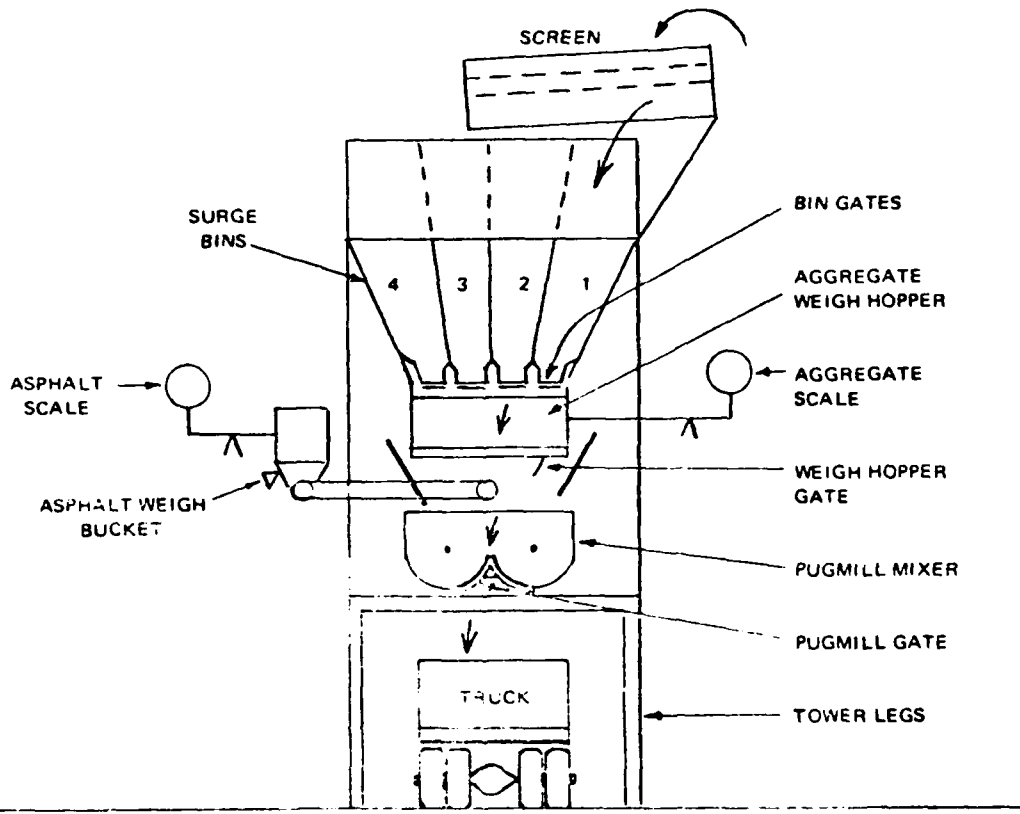

Figure 6. Weigh batch plant—schematic operation.

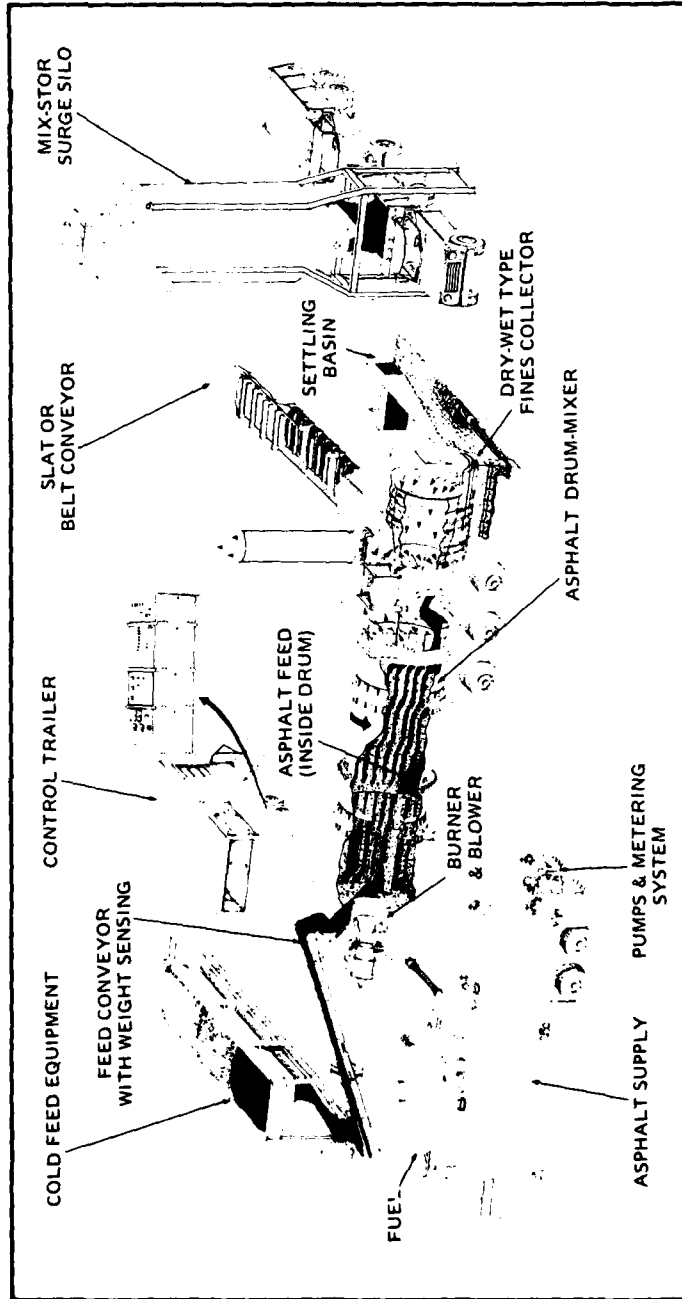

Figure 7. Drum mix process.

(2) **Weigh Batch Plant.** When the aggregate materials are dumped into the pugmill they are still partially segregated from being layered in the weigh hopper. Thus 10 to 15 s of dry mixing is done prior to the spraying (or dumping) of the asphalt cement into the pugmill. The ingredients are then wet mixed (usually 30 to 45 s) and the batch is dumped into the truck. The time required for opening, dumping, and closing the gate is dead production time.

c. **Drum Mix.** The latest development in design of asphalt plants is the Drum Mix type. Drum mixing is a simple, low-cost (comparatively speaking) method of producing quality asphalt mixes.

The basic drum mixer is similar in configuration to a conventional aggregate dryer. The major difference is that aggregate is not only heated and dried within the dryer drum, but also coated with an asphaltic material.

This arrangement eliminates several major components necessary in the continuous or weigh batch method of manufacturing asphalt mixes. Since the drum mix process depends on cold feed control for aggregate gradation, the gradation screen, hot aggregate storage bins, hot elevators, aggregate measuring systems, and mixing chambers are eliminated. A drum mix plant does, however, require the use of a mix storage bin or surge silo system for mix loadout into trucks.

The deletion of major components allows the drum mix plant to be purchased at a lower cost than a continuous mix or batch plant of comparable capacity. With fewer components, the drum mix plant is normally easier to move, erect, and maintain.

There are several other advantages of the drum mix principle. Due to its continuous mode of operation, once a drum mix plant is calibrated and set for a particular mix, it is capable of maintaining high production rates. This is accomplished by operating at lower mix discharge temperatures, and by retaining some moisture in the aggregate, less drying effort is required which translates into lower fuel consumption.

The drum mix plants are now being used to recycle reclaimed material. The reclaimed material is added to the material flow at a controlled rate so the required ratio of all material is constantly maintained. Again this procedure is being used to reduce the cost of producing a high quality mix.

Two major areas of concern when considering the selection and operation of an asphalt mixing plant are the environment and energy.

In the drum mix process, two types of air pollution emissions are normally encountered. They are particulate emissions and blue smoke emissions. One of the advantages of the drum mix process is the minimizing of particulate matter in the exhaust gases. This occurs because the fine aggregate (dust) particles are agglomerated and coated with asphalt. Pollution control equipment requirements are thus less complex than with other types of asphalt plants. Blue smoke is composed primarily of an aerosol mist of unburned hydrocarbons. There is no practical device to collect blue smoke once it occurs. It can be prevented by proper equipment design and operating procedures.

Because drum mixing is a continuous process, it is necessary to hold completed mix for truck loadout. This is normally accomplished with a hot mix surge system. The surge system will consist of two basic units; a conveyor and a surge bin.

The types of conveyors used are enclosed belt conveyors, enclosed drag conveyors, or enclosed bucket-type elevators. The mix is discharged from the drum into the conveyor receiving hopper, conveyed to the top of the surge bin, and discharged down the center of the surge bin.

The surge bin can be designed to provide short-term hot mix storage tailored to the plant capacity or multiple silos for large-capacity installations.

The silos range in size from 40- to over 200-ton capacities. The silos are normally insulated and equipped with an auxiliary heating system to retain the mix temperature until it is loaded into trucks.

As stated before, the drum mixing method of producing hot mix asphalt would have certain advantages to a military-type operation. The process is rather simple and efficient. Mobility is better than the other types of plants of comparable capacity. The need for pollution control equipment is minimized. The production of lower temperature mixes will result in fuel savings at a higher plant capacity.

If portability and high hourly production are desired, it is recommended that the military give strong consideration to the procurement of the drum mix type plant.

Today, the asphalt plant equipment manufacturers are no longer manufacturing continuous type plants as a normal production line item. The weigh batch type plants are still being manufactured but on a limited scale. Most of the Industry's research, development, and manufacturing efforts are directed towards the drum mix type plant.

7. Plant Support Equipment.

a. **Heater/Storage Tank (Figure 8).** The portable bituminous storage tank is a mobile asphalt storage tank of 5,000-gal capacity consisting of an insulated steel tank equipped with chassis, heating coils, and necessary valving components. The heating coils are designed for connections to an independent, hot-oil heating source.

The vehicle is designed for storage use only and is not designed for transport use. The vehicle must always be blocked at the proper location before being filled with material.

Four 5,000-gal storage tanks are authorized with each asphalt mixing and paving set. These units, when connected in series, will adequately support the present military size plant. But commercial plant operators have found that it is more economical for heating and there is less heat loss in much larger bulk storage tanks.

At present, there are no bulk-type asphalt transport vehicles in the Army supply system. This is a need that should be investigated.

Commercial producers that move their plants from job site to job site are investing in combination heaters and storage tanks mounted on a semi-trailer. The types of heaters available are oil or gas fired and/or electric. The storage tank can be a single asphalt storage compartment or a combination of asphalt, fuel oil, and heat exchange oil tanks. The storage capacity range available varies from 5,000 to 25,000 gal.

As stated, the above equipment is used for storage only. To support a major plant operation, bulk asphalt will be required and bulk transporters will have to be added to the plant support equipment inventory.

b. **Hot Oil Heater.** The hot oil heater is a trailer-mounted, heavy-duty, high-output oil-fired heater. The heater is designed to heat a transfer oil and pump this oil to the external systems requiring heat. After the heated oil circulates through the external unit, such as a melter or storage tank, it is returned to the heater.

This heating method has been widely accepted throughout industry as very economical.

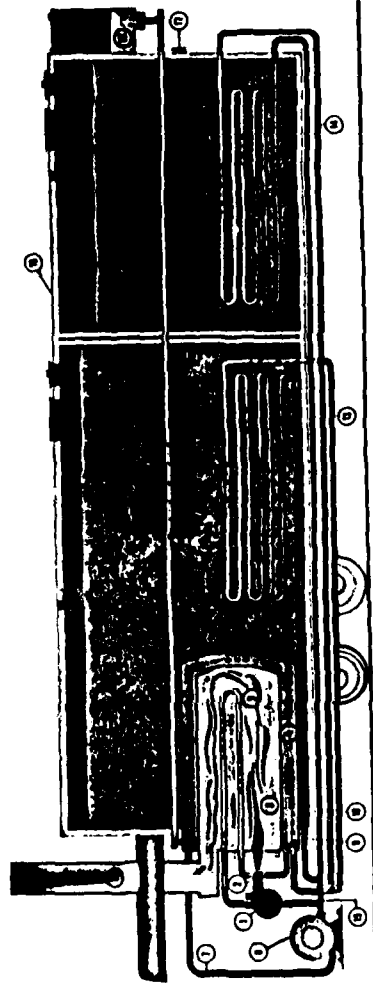

1. Blower
2. Burner
3. Fire Chamber
4. Heat exchange oil
5. Wet baffle
6. Exhaust
7. Hot oil to circulating pump
8. Circulating pump
9. Hot Oil to No. 1 compartment
10. Hot Oil to No. 2 compartment
11. No. 1 Coil Pack
12. No. 2 Coil Pack
13. No. 1 Oil Return
14. No. 2 Oil Return
15. Oil to Wet Baffle
16. Expansion Tank
17. Tank Temperature Controller (2)
One for Each Compartment
18. Anti Slip Walkway

Figure 8. Heater/storage tank.

In areas where electric power is available at economical rates, some commercial plant operators are using electric heating elements to heat the oil or heat the external units that require heating.

8. Electric Plant Operation. The trend today in Commercial Construction Plant Equipment (Asphalt, Crushing and Concrete) is all toward electric plant operation with electric control. The benefits of this are:

- Ability to apply power at point of need, simplifying engineering and plant setup.
- Ability to add or deduct components without affecting mechanical drive mechanisms or other units in set.
- Centralized location of power controls (eliminating manpower).
- Centralized operational control—console-type controls.
- No engine maintenance (if high line power is used).
- Wide flexibility in adopting new design features requiring finite, infinite, proportional, type, etc., controls.

While the basic diesel-mechanical driven plant owned and specified by the Military today offers these benefits:

- Self-contained power.
- Easily maintained simple mechanical drives.
- Two-engine operation for complete plant.

The trend in industry by all manufacturers is toward the all-electric plant setup. All new ideas and design concepts in asphalt plant operations are only obtainable with electric power drives and/or electric control mechanism. The diesel-driven plants from any manufacturer are far behind the state-of-the-art.

The Military should give serious consideration to specifying and purchasing completely electrically driven asphalt plant packages complete with adequate generators in future procurements.

9. Paving Operations.

a. **Finishing Machines (Figure 9).** Asphalt finishing machines, commonly known as pavers, in current use are similar in many respects. Normally these machines will consist of two major units, one of which is known as the tractor unit and the other the screed unit.

The tractor unit contains the power source, mix receiving hopper, and controls to guide the machine and regulate the flow of material to the screed. The tractor unit also provides motive power not only for itself and the screed unit, but also to push the truck that is unloading into the receiving hopper. The tractor unit may be crawler or rubber-tired mounted.

The screed unit consists of leveling arms, a screed plate, compacting device(s), crown control and thickness controls. The basic connection between the screed unit and the tractor unit is through the leveling arms which are hinged or pin-connected. In theory, this provides a screed with a so-called *floating action* which spreads the material in the desired configuration. When the forces acting on the screed are balanced between the screed plate and the leveling arms, it leaves a uniform mat. When these forces are changed, the screed will either go up or down increasing or decreasing mat thickness. Thickness control is achieved by changing the tilt of the screed plate. The screed reacts to these changes until they are balanced again during which time the desired thickness is achieved.

All pavers operate basically on the same principle as to leveling and control of thickness.

b. **Automatic Grade Control (Figure 10).** Automatic grade (screed) control for asphalt finishing machines consists of two basic control systems. One is a sensor (longitudinal control) which works off a ski, stringline or other reference and through electronic and hydraulic controls causes one side of the screed to follow the reference. The other system is a slope control (transverse control unit) of a pendulum type which holds the opposite edge of the screed to the preset slope in relation to the movement of the longitudinal control. In some cases, a machine may be operated with two longitudinal controls, if an adequate reference is available on both sides. Current usage has proved that stringlines (or wires) are costly and time consuming to erect and maintain. Thus the 30-ft ski unit is the most popular usage. The ski effectively lengthens the "wheelbase" of the self leveling finisher and causes it to level, or grade, over a greater distance. While these units properly



Figure 9. Finishing machine, Bituminous material.

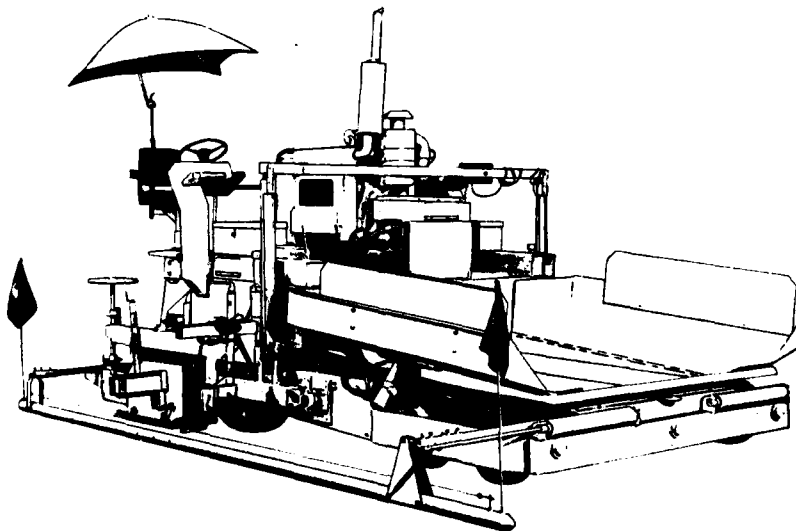

Figure 10. Automatic grade control.

used give a smoother surface and better overall paving job, they do require skill in operation, more maintenance and, generally, slow down the paving operation. Probably the benefits obtained from use of these units would not offset the problems in worldwide use and application by the Military. At this time, adoption of these controls is doubtful.

c. **Vibratory vs Tamper Screeds.** Today's Military Specification allows use of either vibratory or tamping screeds. The definite trend in industry is to the vibratory screed as it is now doing an equal job to the tamping screed and is proving to be less costly and easier to maintain. The heavy vibratory screeds (high energy input) can give densities in the paving mat which may eliminate some or all of the rolling operation. Thus, the new design work being done on screeds and compaction is with vibratory units. Military standardization of vibratory screeds would eliminate the tamping bar from the Military Specifications.

d. **Crawler vs Rubber Tires.** The rubber tired finisher is capturing a good share of the market and is quite popular as an overlay or resurfacing machine. Its ability to maneuver quickly, when not paving, allows it to save time in running back to pick up a new lane (of paving) or in moving (short distances) to another job. These rubber tire machines still require a good firm surface for paving operations and generally are not being used for paving on base or sub-base materials. Since Military construction paving requirements are mainly for new construction work, the crawler machine, which can push loaded trucks in tough going, is still the answer for the overall needs of the Military. Experience indicates that crawler machines should still be specified for the immediate future.

e. **Wide Finishing Machines (18 ft to 30 ft in width).** These units are now becoming available from all manufacturers for use on high production new construction (and, where possible, to close a road completely on repaving jobs). They offer the advantages of one pass down a dual lane highway, no center joint and real high laying capacities (500 ton/h plus). For reasons of capacity, transportation and paving needs, we cannot see their consideration by the Military, at this time. It is felt that the basic 10-ft-wide machine, extendable to 14 ft, which is now specified in the Military Specification, is adequate.

f. **Mix Pickup Units.** Mainly on high tonnage jobs, a combination of large capacity bottom dump (belly dump) trucks are used in conjunction with a mix loader. The trucks dump the hot asphalt mix on the base or sub-base in a window ahead of the finisher. The pickup device, moving ahead with the finisher, picks up, elevates, and discharges the mix into the finisher hopper. The advantages are use of bigger trucks and trailers and no waiting time at the finisher. Since specialized trucks are required, we do not feel this approach will be of interest to the Military.

10. Compaction.

a. **Compaction Equipment.** Adequate compaction is a most important part of any paving operation. There are several types of compactors used by the commercial industry, such as vibrating shoe, steel-wheeled rollers, pneumatic-tired rollers, two- and three-axle tandem rollers, and vibrating rollers. But the types generally used now for compaction of asphaltic mixes are: two-axle tandem, self-propelled pneumatic-tired, and self-propelled vibratory.

It is felt that, with the commercial and modified commercial compaction equipment presently fielded and in Army usage, the Military has the size and type of equipment required for asphalt compaction.

b. **Two-Axle Tandem Roller.** The Military adopted 10- to 14-ton two-axle tandem roller is designed to compact base course material and asphaltic concrete material. On asphaltic concrete materials, the unit can be used for both breakdown and finish rolling. The unit has proven to be very adequate for both functions.

The roller design includes the latest in the state-of-the-art for mechanical innovations, operator control, and visibility.

c. **Self-Propelled Pneumatic-Tired.** The self-propelled, pneumatic-tired roller can be used for all stages of base and asphalt compaction. On asphalt compaction, the unit is normally used for secondary rolling.

The optional components required for asphalt compaction were included during the procurement of the rollers. These options are air on-the-go and water spray system.

Air on-the-go assures identical pressure in each of the nine tires. Tire pressure is adjustable from 35 to 130 PSI while rolling, enabling the operator to adjust tire pressure most suitable for the material being compacted.

d. **Self-Propelled Vibratory Roller.** The Military adopted, self-propelled vibratory roller is designed to compact granular soils, base course material, and with required options, asphaltic materials.

The commercial industry is researching intensively the use of vibrations for compacting all types of asphaltic material. The vibratory roller procured by the Military does not include the optional components for compacting asphaltic material. Therefore, the Military vibratory roller cannot be used effectively on asphaltic pavements. In view

of this, the commercial industry's research should be closely monitored and if it proves justifiable, change the vibratory roller requirements documentation to include the optional components needed for bituminous compaction.

11. Surface Treatments. Surface treatments are bituminous-aggregate coverings applied to any type of road or pavement surface. The construction of these treatments is simply an application of a bituminous binder followed by a covering of aggregate. Normally, the treatment contributes nothing to the load carrying ability of the surface being treated but provides protection from traffic wear and seals it from moisture.

Surface treatments can be constructed with a minimum of equipment. The basic equipment required is a dump truck, aggregate spreader, bituminous distributor, and compaction equipment.

a. **Dump Trucks.** The fleet of commercial dump trucks procured by the Military includes the latest state-of-the-art in dump body design to include an adjustable tailgate.

The adjustable tailgate is to provide a controlled, uniform, spread layer of aggregate (uniform sized crushed stone) while traveling forward or rearward.

Therefore, in an emergency situation, the commercial dump truck could be used in surface treatment as the aggregate spreader.

But, under normal conditions, the required control of aggregate quantity and application would be much greater than could be obtained by the truck tailgate. Therefore, an aggregate spreader should be used.

b. **Aggregate Spreaders.** There are basically three types of aggregate spreaders used by state, county, and commercial users. They are: the tailgate vane spreaders, mechanical-towed spreaders, and the engine-driven, self-propelled spreaders.

c. **Self-Propelled Spreader (Figure 11).** The type normally used by commercial contractors on surface treatment applications requiring strict aggregate control will be the engine-driven, self-propelled spreader.

The self-propelled spreader is preferred over the other units because it combines high productivity, positive control of aggregate flow, extreme maneuverability, and safer operation. The unit is, also, compatible with most dump trucks and allows for changing trucks *on the run* for maximum productivity and operating efficiency.

Economical savings are substantial over a large project because positive control over aggregate flow means little or no aggregate waste and there is less manpower required during the operation. The spreader operator's clear view of the spread edge insures an even longitudinal line eliminating costly hand work to cover joints. Extreme maneuverability of the spreader saves time when winging intersections and working in small areas.

The Navy and Air Force have adopted the self-propelled spreader as a standard item of issue.

d. **Mechanical-Towed Spreader (Figure 12).** The Army adopted mechanical spreaders are hoppers on wheels which are hooked to and are propelled by a dump truck equipped with a spreader towing hitch. The wheels which support the spreader also provide power to operate an auger and aggregate feed roller in the bottom of the hopper. The feed roller forces aggregate out of a control gate to the road surface.

There are several problems associated with the operation of a towed spreader. First, the spreader can only be used with trucks that have a special towing hitch installed. The commercial dump truck used by the Army has a heaped load capacity of 19 plus cubic yards and an overall width of 96 in. When used with the spreader, you have a 19-yd³ feeding into a 96-in.-wide, 1-y³ hopper. It is extremely difficult to maintain a constant flow of material into the spreader without spillage in front, rear or sides of the spreader. Also, the truck driver must maintain a steady speed and control the longitudinal alignment of the spreader while moving backwards in most surface treatment operations.

The towed spreader is no longer being manufactured as a standard, commercial, production line item. In view of this, the Army should give strong consideration to obsoleting the towed spreader and replace it with the procurement of self-propelled aggregate spreaders.

e. **Bituminous Distributor.** One of the most popular items of equipment on any bituminous project is the bituminous distributor.

It is felt that the recent procurement of the commercially designed 1500-gal bituminous distributors gives the Army the latest state-of-the-art equipment regarding spray control, operator control, and maintainability.

However, consideration should be given to increasing the tank size to take full advantage of the load-carrying capability of the commercial truck chassis and, also, the material heating system.



Figure 11. Self-propelled spreader, aggregate.

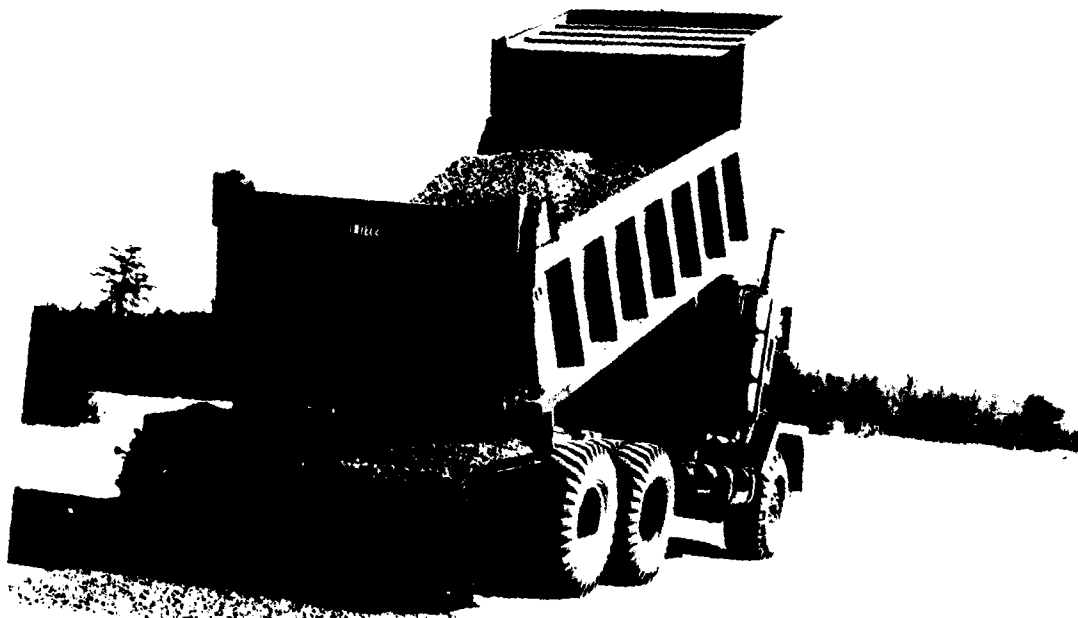

Figure 12. Mechanical towed spreader, aggregate.

f. **Compaction Equipment.** The tandem axle roller and the self-propelled, pneumatic-tired units are very effective units for surface treatments compaction.

g. **Distributor, Dust Control Material (Figure 13).** The dust control equipment is a rubber-tired, sectionalized vehicle consisting of a prime mover (power section) and a tanker (distributor section). All wheels are powered and the sections are capable of being coupled and uncoupled.

The prime mover has a single axle with large tires for high flotation and off-road mobility. It, also, has two retractable wheels which permit the unit to move short distances on level terrain while separated from the distributor section. The power section utilizes standard Army fuel and off-the-shelf components.

The distributor section has tandem axles and uses the same size tires as the prime mover section. This section consists of a two-compartment stainless steel tank, one for dust control material and one for water. The material tank has a capacity of approximately 1,500 gal and the water tank has a capacity of approximately 375 gal. The distributor section is capable of self-loading from 55-gal drums and of simultaneously applying water for preconditioning the soil, the fiberglass scrim for reinforcing, and the dust control material. It is, also, capable of heating and applying various grades of asphalt materials although this is not required by the qualitative materiel requirement (QMR).

The equipment was type classified Standard with Logistics Control A in September 1975.

After type classification (T/C), DA informed MERADCOM that the need for a dust control system had diminished, and that no procurement was planned. DA directed MERADCOM to put the technical data package (TDP) in storage in case of a future need.

The distributor is a military designed item that is air transportable and when sectionalized can be transported by helicopter.

If the need should arise for an air mobile Bituminous Distributor, consideration should be given to modifying the TDP and procuring this unit.

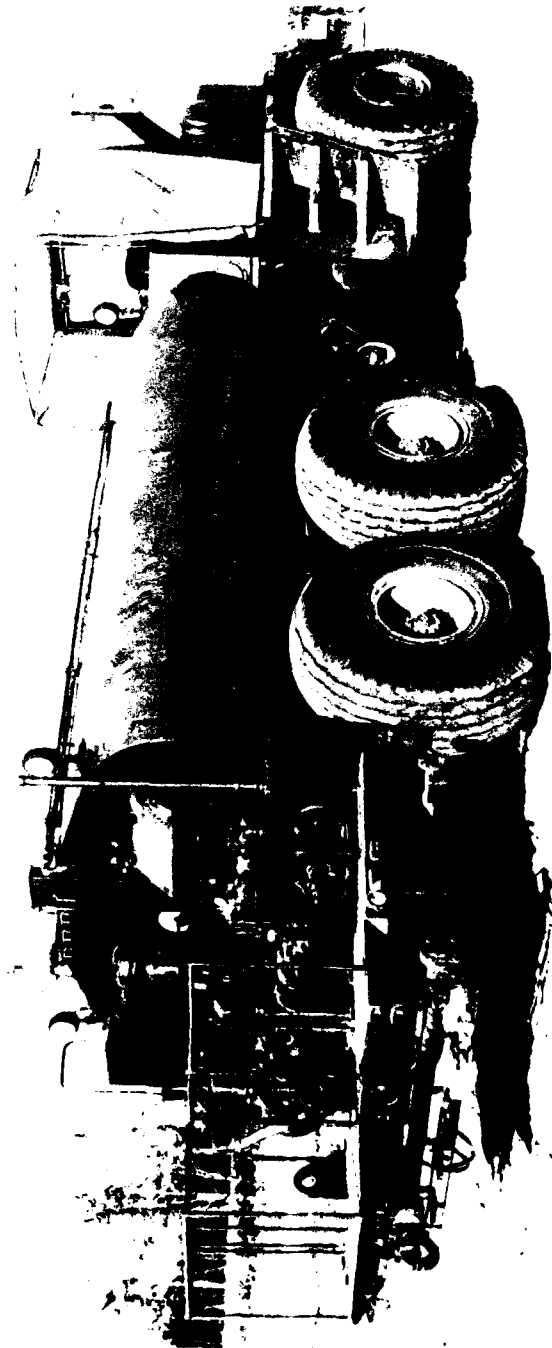

Figure 13. Distributor dust control material.

DISTRIBUTION FOR MERADCOM REPORT 2351

No. Copies	Addressee	No. Copies	Addressee
	Department of Defense		
1	Director, Technical Information Defense Advanced Research Projects Agency 1400 Wilson Blvd Arlington, VA 22209	1	Director US Army Material Systems Analysis Agency ATTN: DRXSY-CM Aberdeen Proving Ground, MD 21005
12	Defense Tech Info Ctr Cameron Station Alexandria, VA 22314	1	Director US Army Materiel Systems Analysis Agency ATTN: DRXSY-MP Aberdeen Proving Grounds, MD 21005
	Department of the Army		
1	Commander, HQ TRADOC ATTN: ATEN-ME Fort Monroe, VA 23651	1	Director US Army Engineer Waterways Experiment Station ATTN: Chief, Library Branch Technical Info Ctr Vicksburg, MS 39180
1	HQDA (DAMA-AOA-M) Washington, DC 20310		
1	HQDA (DALO-TSM) Washington, DC 20310	1	Commander US Army Armament Research and Dev Com ATTN: DRDAR-TSS No. 59 Dover, NJ 07801
1	HQDA (DAEN-RDL) Washington, DC 20314		
1	HQDA (DAEN-MPE-T) Washington, DC 20314	1	Commander US Army Troop Support and Aviation Materiel Readiness Com ATTN: DRSTS-MES (1) 4300 Goodfellow Blvd St Louis, MO 63120
1	Director Army Materials and Mechanics Research Center ATTN: DRXMR-PL Technical Library Watertown, MA 02172	2	Director Petrol & Fld Svc Dept US Army Quartermaster School Fort Lee, VA 23801
1	Commander US Army Aberdeen Proving Ground ATTN: STEAP-MT-U (GE Branch) Aberdeen Proving Ground, MD 21005	2	Engineer Representative USA Research & Standardization Group (Europe) Box 65 FPO 09510

No. Copies	Addressee	No. Copies	Addressee
1	HQDA ODCSLOG DALO-TSE Room 1E588 Pentagon, Washington, DC 20310	5	Commander US Army Materiel Development & Readiness Com ATTN: DRCDE 5001 Eisenhower Ave Alexandria, VA 22333
1	Commandant US Army Engineer School ATTN: ATZA-CDD Fort Belvoir, VA 22060		MERADCOM
1	Commander Headquarters, 39th Engineer Battalion (Cbt) Fort Devens, MA 01433	1	Commander, DRDME-Z Technical Director, DRDME-ZT Assoc Tech Dir/R&D, DRDME-ZN Assoc Tech Dir/Engrg & Acq, DRDME-ZE Spec Asst/Matl Asmt, DRDME-ZG Spec Asst/Scs & Tech, DRDME-ZK CIRCULATE
1	President US Army Armor and Engineer Board ATTN: ATZK-AE-PD-F Fort Knox, KY 40121	1	C, Ctrmine Lab, DRDME-N C, Engy & Wtr Res Lab, DRDME-G C, Elec Pwr Lab, DRDME-E C, Camo & Topo Lab, DRDME-R C, Mar & Br Lab, DRDME-M C, Ctr Intrus Lab, DRDME-X C, Matl Tech Lab, DRDME-V Dir, Product A&T Direc, DRDME-T CIRCULATE
1	Commander USATACOM ATTN: DRSTA-GBW Warren, MI 48090	1	Mech & Const Equip Lab, DRDME-H
1	Commander USATACOM ATTN: DRSTA-GBC Warren, MI 48090	2	Const Eng Equip Div, DRDME-HK
1	Commander USATACOM ATTN: DRSTA-MVM Warren, MI 48090	25	Special Projects Grp, DRDME-HKP
1	Commander USATACOM ATTN: DRCPM-CET Warren, MI 48090	3	Tech Rpts Ofc, DRDME-WP
1	Commandant US Army Logistics Eval Agency ATTN: DALO-LES NCAD New Cumberland, PA 17070	3	Security Ofc (for liaison ofcers), DRDME-S
		2	Tech Library, DRDME-WC
		1	Programs & Anal Dir, DRDME-U
		1	Pub Affairs Ofc, DRDME-I
		1	Ofc of Chief Counsel, DRDME-L
			Department of the Navy
		2	Commander, Naval Facilities Engineering Com Department of the Navy ATTN: Code 032-B, 062 200 Stovall St Alexandria, VA 22332

No. Copies	Addressee
1	Library (Code L08A) Civil Engineering Lab Naval Construction Battalion Ctr Port Hueneme, CA 93043
Department of the Air Force	
1	US Air Force HQ Air Force Engineering & Services Ctr Technical Library FL 7050 Tyndall AFB, FL 32403
1	Department of Transportation Library, FOB 10A, M494-6 800 Independence Ave., SW Washington, DC 20591
Others	
1	Professor Raymond R. Fox School of Engineering and Applied Science George Washington University Washington, DC 20052