

AD-A116 270

ARMY WAR COLL CARLISLE BARRACKS PA
THE ECHELONS ABOVE DIVISION MEDICAL SUPPORT STRUCTURE TO SUPPOR--ETC.(U)
APR 82 J E LOMBARD

F/8 6/5

UNCLASSIFIED

NL

END
DATE
FORMED
8 82
DTIC

END
DATE
FORMED
8 82
DTIC

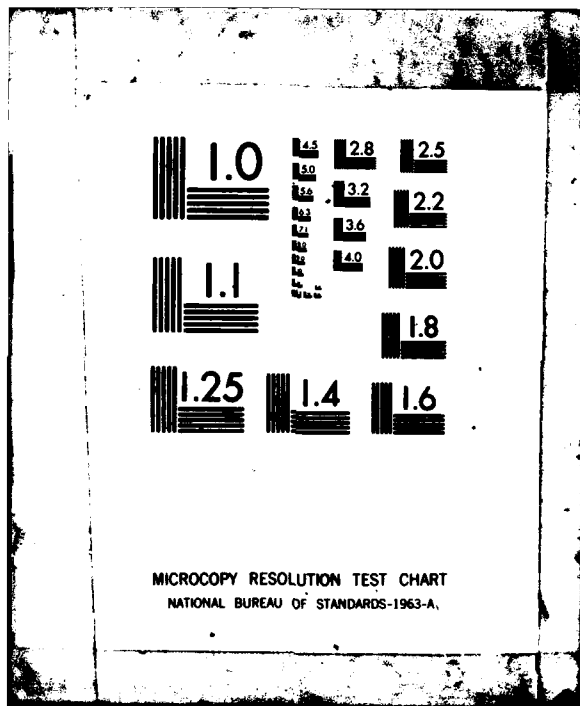

MICROCOPY RESOLUTION TEST CHART
NATIONAL BUREAU OF STANDARDS-1963-A.

AD A116270

| REPORT DOCUMENTATION PAGE | | READ INSTRUCTIONS BEFORE COMPLETING FORM |
|---|---|---|
| 1. REPORT NUMBER | 2. GOVT ACCESSION NO. AD-A116 270 | 3. RECIPIENT'S CATALOG NUMBER |
| 4. TITLE (and Subtitle) The Echelons Above Division Medical Support Structure to Support Structure to Support the Army for the Field in the 1986-2000 Timeframe | | 5. TYPE OF REPORT & PERIOD COVERED Student Essay |
| 7. AUTHOR(s) James E. Lombard | | 6. PERFORMING ORG. REPORT NUMBER |
| 9. PERFORMING ORGANIZATION NAME AND ADDRESS US Army War College Carlisle Barracks, PA 17013 | | 8. CONTRACT OR GRANT NUMBER(s) |
| 11. CONTROLLING OFFICE NAME AND ADDRESS Same | | 10. PROGRAM ELEMENT, PROJECT, TASK AREA & WORK UNIT NUMBERS |
| 14. MONITORING AGENCY NAME & ADDRESS (if different from Controlling Office) | | 12. REPORT DATE April 1982 |
| | | 13. NUMBER OF PAGES 33 |
| | | 15. SECURITY CLASS. (of this report) Unclassified |
| | | 15a. DECLASSIFICATION/DOWNGRADING SCHEDULE |
| 16. DISTRIBUTION STATEMENT (of this Report) Approved for public release; distribution unlimited. | | |
| 17. DISTRIBUTION STATEMENT (of the abstract entered in Block 20, if different from Report) | | |
| 18. SUPPLEMENTARY NOTES | | |
| 19. KEY WORDS (Continue on reverse side if necessary and identify by block number) | | |
| 20. ABSTRACT (Continue on reverse side if necessary and identify by block number) This document presents an overall operational concept for health services in an active theater of operations during the 1986-2000 timeframe. The emphasis is placed on the medical support requirements above division level and includes corps and theater level medical support requirements. (Medical requirements rearward of the COMZ are not addressed) in this paper. The recent Division 86th studies and the revived concern for the environment of the integrated battlefield were the primary factors which motivated this paper. This paper emphasis is on health services concepts, organization, and systems that vary | | |

(see over)

SECURITY CLASSIFICATION OF THIS PAGE (When Data Entered)

Item 20 continued

significantly from today's doctrine.

A

SECURITY CLASSIFICATION OF THIS PAGE (When Data Entered)

THE ECHELONS ABOVE DIVISION MEDICAL
SUPPORT STRUCTURE TO SUPPORT THE ARMY
IN THE FIELD IN THE 1986-2000 TIME FRAME

The views expressed in this paper are those of the author and do not necessarily reflect the views of the Department of Defense or any of its agencies. This document may not be released for open publication until it has been cleared by the appropriate military service or government agency.

by

James E. Lombard
USAWC Class of 1982



| | |
|--------------------|-------------------------------------|
| Accession For | |
| NTIS GRA&I | <input checked="" type="checkbox"/> |
| DTIC TAB | <input type="checkbox"/> |
| Unannounced | <input type="checkbox"/> |
| Justification | |
| By _____ | |
| Distribution/ | |
| Availability Codes | |
| Dist | Avail and/or Special |
| A | |

Approved for public release
distribution unlimited.

PURPOSE.

The purpose of this document is to present an overall operational concept for health services within an active theater of operations in the 1986-2000 time frame. This paper will place its emphasis on medical support requirements above division level and will include corps and theater level medical support. Medical support requirements rearward of the COMMZ will not be addressed in this paper. In other words this document will address the medical support required in a theater of operations from the division rear area to the "waters edge." Emphasis will be placed on the concepts, organization, and systems that vary significantly from today's doctrine.

GENERAL

The recent organizational changes and operational concepts that evolved out of the Army 86 studies require a relook at how this new Army must be supported in the field. The new divisions produced by these studies will have greater mobility, be more difficult to sustain, and will utilize modern technology to the maximum. Within these new divisions, the medical support package has been significantly upgraded. This increased support includes improvements in both the personnel and equipment areas and ensures that the medical support package has a greater capability and is more survivable on the modern battlefield. Most notable the medical evacuation and treatment assets have been hardened and organized to match the mobility of the units they are supporting. To adequately support these divisions and their improved medical support package, the medical support at echelons above division, both at corps and COMMZ, must be significantly improved and streamlined.

The nature of today's modern integrated battlefield with the presence of conventional, nuclear, chemical, and perhaps biological weapons greatly

complicates the overall planning for medical support. Due to the nature of the integrated battlefield, the primary impact on health services operations will be in the form of a significant increase in the anticipated number of casualties and the presence of nuclear and/or chemical contamination. The introduction of biological agents by the enemy force would further overload our limited medical capability. The large casualty load that will be generated by the integrated battlefield will place increased importance on the triage process. The current triage system (see Annex 3) has been repeatedly studied and is believed to be the optimum method of handling large numbers of casualties when medical support assets are limited. Primary considerations in how the triage will be conducted are where it will be conducted and who will be available to conduct it. When large numbers of casualties are immediately available at the incident site, triage is best accomplished at the site in order to insure the appropriate priority of evacuation to medical treatment facilities. When the nature of the incident precludes the rapid acquisition of the casualties (i.e., a large nuclear explosion) and adequate evacuation means are available, the triage is best accomplished at the medical treatment facility. In order to preclude contaminating the limited number of medical personnel, equipment and facilities available, decontamination of the casualty becomes extremely important. Due to the potentially large number of casualties that may be contaminated and the limited number of medical personnel available, the majority of decontamination must be accomplished by other than medical personnel and self aid/buddy aid administered. These activities should be under medical supervision to be most effective and to insure that the patient does not suffer additional trauma. Prompt action is essential; if decontamination of the casualty is not initiated almost immediately his chances of survival have been significantly reduced.

In addressing the overall subject of theater health service support this paper will present the corps and the COMMZ support requirements in separate discussions. Additionally, these support requirements will be further subdivided into discussions of the conventional theater of operations and contingency operations.

ASSUMPTIONS AND LIMITATIONS

- Host nation support will be utilized to the maximum and will vary greatly in different theater of operation.

- Combat operations will be on an integrated battlefield.

- A conventional theater of operations equates to the NATO or Korea model where significant numbers of U.S. troops are present at the onset of hostilities.

- A contingency operation assumes that there are few, if any, U.S. forces present in the area at the onset of hostilities or the threat thereof.

- The Army will maintain the same basic organizational structure throughout the 1986-2000 time frame (division, corps, COMMZ, etc.).

OPERATIONAL CONCEPT

General. The basic requirements for an effective health service support system are twofold.

- Timely evacuation of patients to the appropriate available treating facility, utilizing effective management of air and ground ambulances in conjunction with the timely out-of-zone aeromedical evacuation of patients by the Air Force.

- Provide appropriate medical treatment through a system of progressive levels of health service support beginning with the unit and station or dispensary and progressing through a system of increasingly more sophisticated

treatment facilities. This system of phased health services support will provide continuous care. In general, each higher level of health service support contains a treatment capability which is more sophisticated than the previous level. In order for each level of health service support within the theater to perform its level of patient management and other functions, the lower levels in the forward areas will be supported by higher levels to the rear. For example, the evacuation of patients from the lower level is the responsibility of the next higher level of support.

Additionally, improvements in the health services support system will accomplish the following:

- Enhance the capability to more rapidly acquire patients.
- Increase the treatment capability and the flexibility of medical treatment facilities.
- Increase the capability to reconstitute forward medical units from a higher level of medical support.
- Produce a more efficient and effective command and control structure.
- Improve the medical logistics system.

Allied patients evacuated to U.S. facilities will be provided the same care as U.S. patients. At the earliest possible time patients will be transferred to facilities operated by their country. These transfers will be coordinated by medical liaison teams. Every effort should be made to keep the number of patients to this category to a minimum since both allied and U.S. facilities will be heavily taxed.

CONVENTIONAL CORPS

- Command and Control. The overall medical command and control within a corps area is the responsibility of a medical brigade. This medical brigade is under the corps support command and the brigade commander also functions as

the corps surgeon, a special staff officer to the corps commander. Subordinate to the medical brigade are two or more medical support groups. The medical support group combines the function of command and control with the hospitalization mission. From a command and control aspect, this element will replace the present medical group and medical battalion headquarters and will control all the medical support functions in the corps area. The hospitalization capabilities of this organization will be discussed in the hospitalization paragraph below. The formation of this unit reduces the number of personnel required for command and control of administration and logistics. (See Figures 6 and 7)

• Hospitalization -- The required hospitalization within the corps area is provided by the previously mentioned medical support groups and the mobile army surgical hospital, (MASH). Present doctrine for medical support to a corps is one MASH (60 beds), one combat support hospital (200 beds), and 2 evacuation hospitals (400 beds) in support of each division. The new hospitalization concept for the Corps will consist of one MASH and two medical support groups in support of each division. The medical support group will normally be configured with a 500-bed capability, however, hospital units can be added or deleted from the headquarters to tailor it to its mission requirements. The medical support group has the additional capability of being split and operated as two separate medical treatment facilities. Therefore, this new organization not only provides an increased hospitalization capability, it reduces the administrative overhead and eliminates the current combat support hospital and the evacuation hospital from the force structure. (See Figures 6 and 7) By reducing the types of hospitals in the force structure, greater flexibility in the utilization of the treatment facilities is accomplished. As we shall see later, this organization also has great utility as a COMZ level medical unit.

• Medical Treatment -- The separate medical company, presently in the force structure, will be significantly modified to provide an increased medical treatment capability. This unit is deployed in an area support role on an as needed basis and will be under the command and control of a medical support group. The increased medical treatment capability of this unit not only provides better medical support to the corps rear area, it can also be utilized to reconstitute division level medical support units that may become attrited or rendered ineffective. This reconstitution capability is a necessity on the integrated battlefield where there is a possibility of having entire units destroyed.

• Medical Evacuation -- Corps medical evacuation assets consist of Air Ambulance and Ground Ambulance Units which are normally placed in support of divisions with the mission of moving patients from the division to the Corps medical treatment facilities or are placed in support of a corps with the mission of providing support to the corps rear and moving patients to medical treatment facilities and Air Force aeromedical staging facilities. U.S. Air Force airlift resources augment and complement the above Army evacuation capability by assisting with the movement of patients within the corps and by evacuating patients from the corps to the COMMZ or CONUS. Air ambulance support: Under present doctrine there are two air ambulance detachments (6 aircraft each) in support of each committed division and one air ambulance company (25 aircraft) in support of each corps. The new concept will place one air ambulance company (12 aircraft) in support of each committed division and one air ambulance detachment (6 aircraft) per division supported in the corps rear area. Reconstitution is not normally a consideration in the organization of corps level air ambulance units in that currently only the air assault division is authorized organic air ambulance assets. These two

air ambulance organizations will be under the command and control of the corps medical brigade or a medical support group.

Ground Ambulance Support: Ground medical evacuation is provided by ambulance companies with 36 organic "crackerbox" type ambulances. Due to the anticipated increase in medical evacuation requirements, the new organization of this unit will provide for 18 of these ambulances to be replaced with larger, "minibus" type ambulances to increase the patient carrying capability. This unit could also be called upon to reinforce or reconstitute division level medical evacuation assets.

• Medical Logistics -- Overall medical logistics in the theater is a responsibility of the theater medical commander. Corps level medical logistics is provided by a medical supply, optical, and maintenance (MEDSOM) organization. This unit provides all medical supply functions within the corps in addition to providing optical fabrication support and biomedical equipment maintenance. MEDSOMS are allocated on the basis of one per corps. This organization will be discussed later when the COMMZ medical logistics structure is presented.

• Medical Regulating -- Medical regulating is the function of controlling the flow of patients to insure that each patient is evacuated to the facility that can provide the level of medical care necessary and has the capacity to receive that patient. Every effort should be made to not "over evacuate" the patient and keep him at the lowest possible level within the evacuation chain. Medical regulating within the corps and out of the corps is the responsibility of the medical brigade. Requests for medical evacuation is consolidated at the medical regulating office in each medical support group and provided to the medical brigade who coordinates with the COMMZ command and control element for medical evacuation out of the corps area.

• Miscellaneous Medical Services -- These medical services which include dental, veterinary, environmental health, medical laboratory and blood bank operations will be discussed under COMMZ level medical support.

CONVENTIONAL ECHELONS ABOVE CORPS (EAC)

Theater-wide health service support functions include hospitalization, medical regulating, intra-theater patient evacuation, blood bank services, medical materiel and maintenance, professional consultation of various medical/surgical specialties, and the capability to reconstitute corps health service elements. In addition the following health service functions are provided to the COMMZ area: command control of medical units; medical treatment and hospitalization; patient evacuation and medical regulating; and dental, veterinary, laboratory, and preventive medicine services.

• Command and Control

The Medical Command (MEDCOM) is a major subordinate element of Theater Army (TA); its commander also serves as the Theater Army Surgeon. The MEDCOM provides command control over TA medical units and activities which provide theater-wide health service support.

To facilitate the buildup of the health service support system, the TA command and control is designed to use the same type of headquarters units as found in the corps with the addition of the MEDCOM. This structure provides the flexibility to shift assets to support additional corps buildups, reallocate medical assets to accommodate the patient workload, and reconstitute corps medical units. The utilization of the medical brigade and the medical support group in the COMMZ area further reduces the types of units in the force structure by eliminating the need for hospital centers. (See Figures 4 and 5) The medical brigade will now perform the command and control function formerly accomplished by the hospital center.

• Medical Treatment and Hospitalization

The COMMZ health service support system is designed to provide that level of care to meet the challenges of the operational environment and to play a specific part in the progressive treatment and hospitalization of the ill, injured or wounded soldier. Due to the integrated battlefield environment it must also contain the additional capabilities to augment corps level medical units when their requirements exceed their capabilities or to reconstitute partially or totally attrited corps level medical units. The TA health service support system is designed to provide patient care for the COMMZ and patients evacuated from the Combat Zone. This system must be flexible enough to shift from providing resuscitation and stabilization for patients initially under a JCS 15 day evacuation policy to providing definitive and restorative care under a JCS 60 day evacuation policy in a mature theater. The entire theater hospital system will be considered an "integrated hospital" and use regionalization to reduce redundancy of units. At present the hospital requirements of the COMMZ are satisfied by a mix of General Hospitals (1000 beds), Station Hospitals (200, 300, or 500 beds), and the Field Hospital (400 beds). The introduction of the medical support group into the COMMZ Medical Support System allows for rapid reconstitution of corps medical facilities. Additionally, these hospitals will replace the station and field hospitals presently in the force structure. Under this concept the number of types of basic hospitals within the entire theater of operations will be reduced from eight to three. (See Figures 2 thru 5)

In addition to the hospitalization system, medical treatment in the COMMZ area is accomplished by a series of dispensaries and the medical clearing company. COMMZ medical support is primarily on an area basis based on troop density.

• Medical Evacuation -- The preferred method of medical evacuation out of the COMMZ to CONUS is U.S. Air Force. The alternate method is by military sealift. Within the COMMZ, the preferred mode of evacuation between treatment facilities and airfields is Army air ambulances. Other evacuation means that are available include buses, trains, watercraft. (See Annex 2)

• Medical Logistics -- Initially, resupply to the theater will be provided by the preplanned, time-phased shipment of medical resupply sets from the U.S. Army Medical Materiel Agency (USAMMA) in CONUS. As the theater sustaining period is reached and normal replenishment replaces preplanned resupply, the medical logistical system will expand in the COMMZ. Medical supply, optical, and maintenance (MEDSOM) units are located in the COMMZ based on the density of medical treatment facilities. Each COMMZ MEDSOM has designated corps MEDSOM to which they provide general support in addition to maintaining critical reserves. Requisitions are forwarded from corps and TA MEDSOMs to the MEDCOM Medical Logistics Control Group (MLCG) which coordinates with the USAMMA for filling these requisitions and with the TA MCC for movement of resupplies from CONUS to the MEDCOM. The MLCG will use an automated information system to obtain maximum efficiency with a minimum of MEDSOMs and to insure a consistent high level of fill of critical medical supplies for treatment/hospitalization units.

Medical regulating will be accomplished through a system of medical regulating offices (MRO) which are located at each medical command and control headquarters. Requests for evacuation are consolidated at the MEDCOM MRO. Those intra-theater requests which can be handled by TA medical assets are given designated hospitals, then the movement is coordinated with either the USAF Aeromedical Evacuation Control Office (AECO), MEDCOM medical evacuation assets, or the TA MCC as appropriate. Intra-theater evacuation requests or hospitalization requirements which exceed the Army's medical capabilities are forwarded to the

Joint Medical Regulating Office (JMRO) which is normally collocated with the MEDCOM MRO. If other services have the existing medical capabilities necessary, the patient will be evacuated to that designated hospital. Inter-theater evacuation is coordinated with the Armed Services Medical Regulating Office (ASMRO) for designation of a CONUS hospital. The JMRO coordinates patient movement with USAF AECO or if air is not available or advisable with the U.S. Navy Military Sealift Command (MSC).

● Blood Bank Services -- Each service within the COMMZ is expected to maintain a capability for self support of its own forces. In joint operations, a joint blood control agency is established under the supervision of the TA surgeon. The theater Joint Blood Program Office (JBPO) is responsible for the intra-theater control, collection, processing, storage and distribution of blood products in the TA. The JBPO coordinates with the Military Blood Program Agency (MBPA) for CONUS blood resupply.

● Miscellaneous Health Care Services -- These medical services which include dental, veterinary, environmental health, medical laboratory, and optometric/optical are provided to both the corps and COMMZ by TOE units or teams. These organizations' allocation is based upon the troop population supported or the anticipated workload. Of these services only the dental, optometry, environmental health and laboratory are found below corps level.

MEDICAL SUPPORT FOR CONTINGENCY OPERATIONS

Medical support for contingency operations will require the same services as a conventional theater of operations, however, numerous unique problems are present in contingency operations. The following discussion of support in contingency operations will not address each element of medical support since the same type units are utilized in either situation and the same basic principles apply. Each contingency operation will by its own definition be unique.

For the purposes of this paper, the situation will be worst cased and we will assume that the operational area is in the eastern hemisphere.

CORPS LEVEL MEDICAL SUPPORT

Normally it will be necessary to conduct phased operations depending upon the rate of deployment, conditions existing in the area of operations, and distances from the battle to the appropriate medical treatment facility. Health service support must be based on estimated workload and the battle environment, and designed to immediately return patients to duty or insure their ability to survive evacuation. Since we can assume no host nation support nor third country logistical bases in the area, the medical evacuation chain out of the operational area may be extremely long. This will necessitate a higher degree of stabilization for the patient prior to medical evacuation. Therefore, the medical support at the lower end of the evacuation chain must possess a greater treatment capability than is normally found at that level. At the same time, by the nature of the operation, the support force must be austere as possible. This requires medical elements to be tailored using organic resources augmented as necessary to meet requirements. As a minimum, this could include the ability to give emergency medical treatment onsite, provide dedicated medical evacuation assets with enroute care, and offer that level of care within a prescribed period of time that would insure the patient's survivability during further evacuation.

• Initial Medical Support -- Medical support early in the operation is extremely critical due to force structure constraints, distance to appropriate medical treatment facilities, and the environmental threat to patients. This phase consists of assault forces seizing a base area and continues with the deployment of assault elements to multiple target areas beyond the effective radius of support from the base area. Medical support to these forces will be

by organic medical resources, augmented by those additional resources designed to support the specific size force and its mission. This tailoring of medical in the initial phase is to insure that the appropriate level of medical treatment is administered to help the patient survive evacuation. Medical evacuation must be a coordinated effort between dedicated Army air ambulance assets and USAF air assets accompanied by medical personnel since distance, time, limited airfields, and the combat environment preclude the use of ground ambulance or the single use of Army air or Air Force assets. For those forces operating within the effective support radius of the base areas, medical evacuation can be conducted exclusively by Army air ambulance assets. Forces operating beyond the support radius must evacuate patients by Army air ambulances to those areas which may be used by Air Force assets to evacuate patients to the appropriate treatment facility. Air Force assets, although not dedicated medical evacuation aircraft must be accompanied by medical personnel to provide enroute care since any Air Force aircraft could potentially be an aeromedical evacuation aircraft. In the base areas, medical support must be designed to provide that level of care necessary to resuscitate the patient in such a manner as to safely enable further evacuation. The amount of medical assets required will depend upon US Air Force medical evaluation capability and/or distance to the appropriate medical support. Initially medical resupply to the corps is provided by preplanned time phase shipments of medical resupply sets. As the required resupply levels are determined, normal replenishment replaces preplanned supply. Due to the limited size of the health service support organization in a contingency operation, the medical logistic system will be provided by a medical supply, optical and maintenance unit (MEDSOM) augmented to provide those control functions normally provided by a COMMZ. As the COMMZ medical logistic system is established, this augmentation unit and function will pass to its control. The medical logistic system will be

heavily dependent on USAF assets. In a relatively short contingency operation, whole blood and blood component requirements will be provided from CONUS. As the theater expands, it will necessitate the development of a corps level blood bank service. It is imperative in this phase to establish a medical headquarters element which can be responsible for coordinating medical evacuation, preventive medicine, and blood services. The establishment of all other medical functions is dependent upon the length of the operation and the size of the force to be sustained.

• Follow On Medical Support -- The amount and type of follow on medical support needed will be based on the force required for sustained operations and on the tactical environment. Unit and division-level medical care will continue to use organic assets tailored to provide that level of medical care necessary to meet the supported unit's mission and to insure the patient's survival during evacuation to corps hospitals. Corps hospitals will be deployed in established base areas to provide that level of care needed to resuscitate and insure the patient's survival during evacuation to the appropriate types of hospitals have been established. Medical evacuation, as in the initial phase, will be a coordinated effort between Army air ambulance assets and the U.S. Air Force. Distance, time, and the combat environment will often, again, preclude the use of ground ambulances except in a brigade or division rear areas. As in a conventional operation the remainder of health service support functions must be provided as appropriate to sustain a contingency corps operation.

COMMZ LEVEL MEDICAL SUPPORT

In discussing COMMZ level medical support in a contingency operation it should be pointed out that we may not have what we normally think of as COMMZ level support or it may not be in the same location as in a conventional theater. If the operation remains on a small scale or is of a short duration, a COMMZ

level command and support structure may not be established and the highest headquarters may be the corps or field force. In situations where a COMMZ level headquarters is not established, the Corps medical support structure would be augmented to provide the necessary support.

Health service support functions provided at the COMMZ level would include hospitalization, intra-theater medical evacuation, medical regulating, blood bank services, medical materiel supply and maintenance, dental, veterinary, preventive medicine, and medical consultation. Again this system will provide health services for the COMMZ area and for the patients evacuated from the corps area. The size and composition of the COMMZ level health services support structure will be dependent upon the size of the combat zone force being supported and the length of the contingency operation. The COMMZ medical force will be increased as the size of the corps forces increases. The size of the COMMZ health services structure will be kept to a minimum, yet must be able to provide the required medical support to sustain the operational area. The size of the medical support force will be based upon the anticipated patient workload and the established medical evacuation policy. This medical force structure must possess the capability to expand and support the operational area if it expands into a full theater of operations.

• Medical Command and Control -- The COMMZ health services structure is normally commanded and controlled by a medical command (MEDCOM). However, due to the limited size of the COMMZ medical structure in a contingency operation, the major medical command and control element will normally be a medical brigade. The commander of this major medical command and control element will also function as the Theater Army Surgeon. In the event the theater grows to the point that it resembles a conventional theater of operations, a MEDCOM would be established.

• Medical Treatment and Hospitalization -- The COMMZ health service support system is designed to provide patient care for those patients evacuated from the combat zone and patient care on an area basis for personnel in the COMMZ. The type hospitals utilized will depend upon the theater evacuation policy, the size of the combat zone force supported, the amount of warning time prior to hostilities, and the availability of Air Force medical evacuation assets. If a short theater evacuation policy is established and the combat zone force is one of corps size or less, smaller, more flexible, and more mobile type hospitals will be utilized in the COMMZ area. The corps and theater evacuation policies and the patient workload will dictate the composition of these hospitals. Area medical treatment support within the COMMZ will be provided by hospitals and dispensaries.

• Patient Evacuation and Regulating -- USAF medical evacuation will be the principle mode of patient evacuation from the corps to the COMMZ and from the COMMZ to CONUS in the initial stages of operation. If the operation expands or is prolonged, surface transportation may be utilized for patient evacuation. Coordination of patient evacuation plans with the flow of tactical and logistical traffic into and out of the combat zone will be essential. Both air and ground ambulance units will be utilized in the COMMZ area although if adequate airheads exist and a hard surface road network exists, the requirement for Army aeromedical evacuation units will be reduced. Medical regulating of patients is accomplished through medical regulating offices (MRO) at each medical command control headquarters. The major medical command control element in the COMMZ will have overall responsibility for medical regulating. This will include designating the appropriate COMMZ hospital for patients being evacuated out of the combat zone, coordination with the USAF aeromedical

evacuation element for patient evacuation and coordination with the Armed Services regulating office for the designation of hospital beds for those patients being evacuated to CONUS.

• Medical Logistics -- The management of the theater medical supply, optical fabrication, and biomedical equipment maintenance system is normally under the command and control of a medical logistics control group. Due to the limited size of the health service support organization in a contingency operation, the medical logistics system will initially be under the command control of an augmented medical supply, optical fabrication, and maintenance unit (MEDSOM) which will be assigned to the major medical command control unit in the COMMZ. As the force develops, this augmentation must expand to a Medical Logistic Control Group (MLCG) to support a sustained operation. The COMMZ MEDSOM will be responsible for the resupply of the corps MEDSOM which is in turn responsible for the resupply of corps and division medical units. Initially, resupply to the theater is provided by preplanned, time phased shipments of medical resupply sets. As required, resupply levels are determined, normal replenishment replaces preplanned resupply. Medical supplies are shipped directly to the corps MEDSOM from the CONUS wholesale logistics base when possible. The medical logistics system will be heavily dependent on USAF assets.

• Blood Bank Services -- All military components within a unified command normally maintain a separate military blood program. In a contingency operation of this nature where the vast majority of the personnel are Army, the Army medical structure would have the overall responsibility for the blood program. In a relatively short contingency operation, blood would not normally be drawn from troops in the combat zone due to the short time period involved and the lack of climatization of the personnel. Whole blood and blood component requirements would be provided from CONUS.

• Miscellaneous medical support will be provided on an area basis and will be kept to the lowest level possible. Such functions as dental, laboratory and veterinary services will initially be on an emergency basis only.

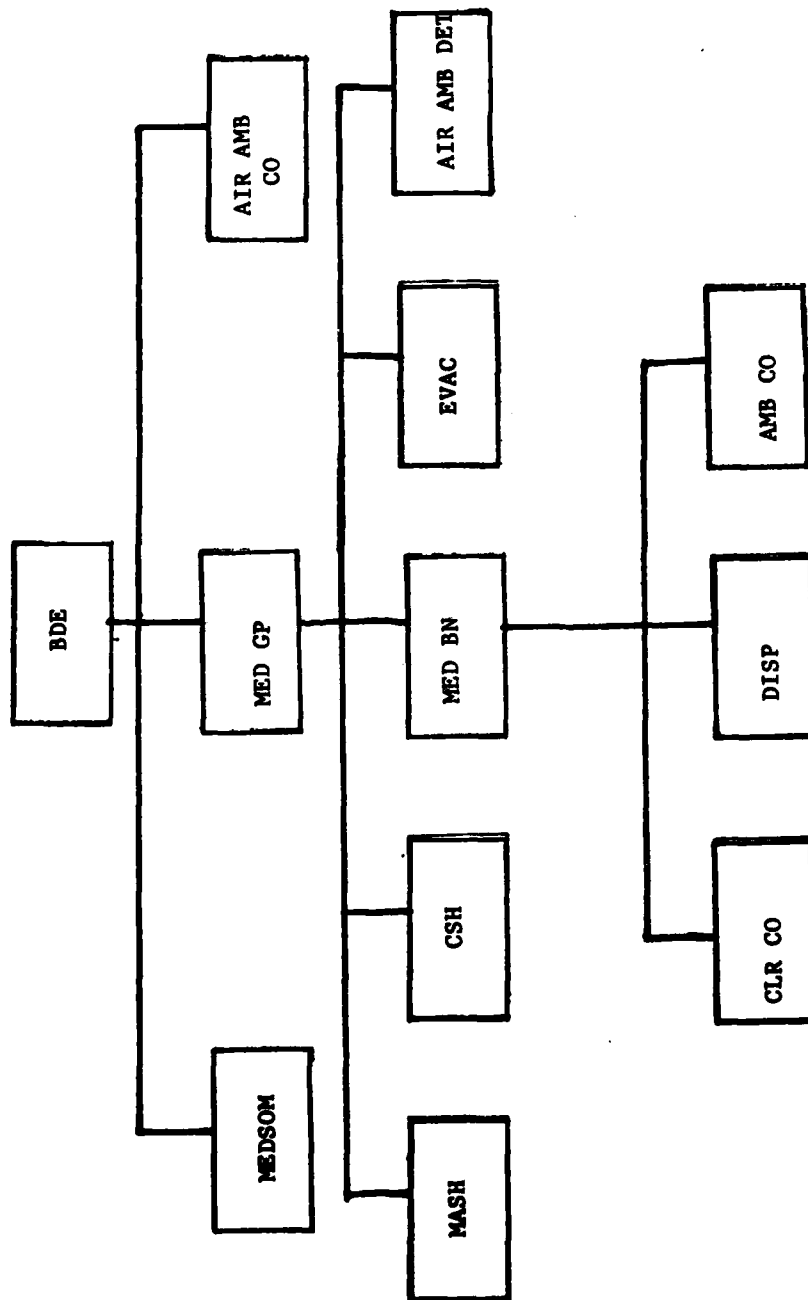

FIGURE 2
CURRENT CORPS MEDICAL SUPPORT STRUCTURE

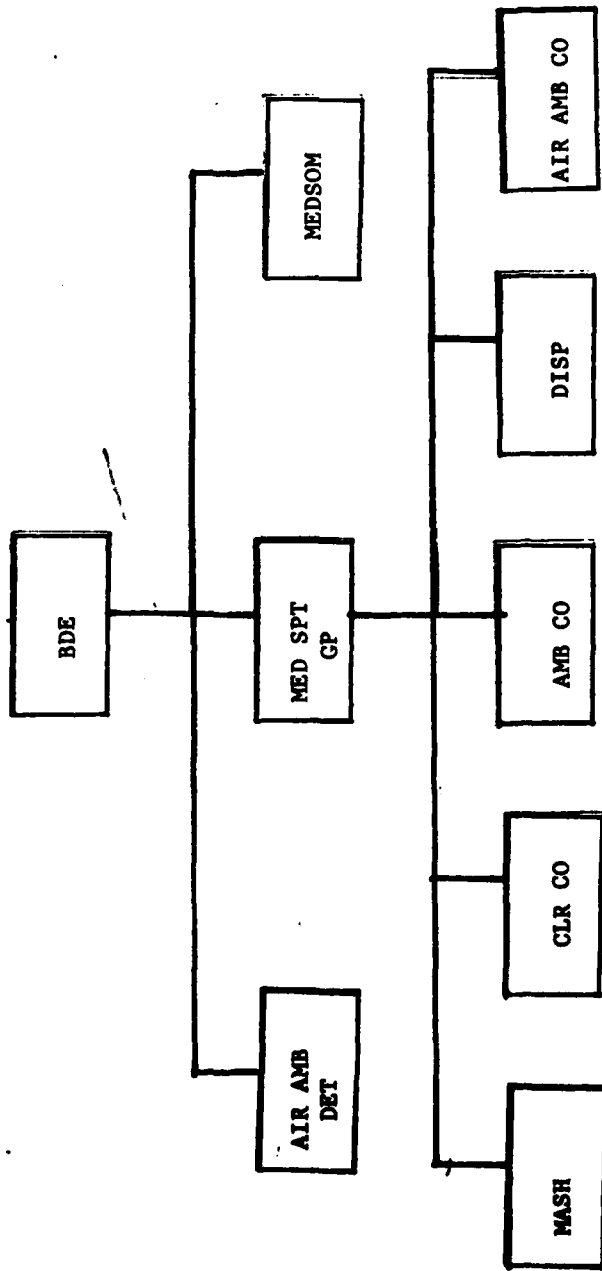

FIGURE 3

PROPOSED CORPS MEDICAL SUPPORT STRUCTURE

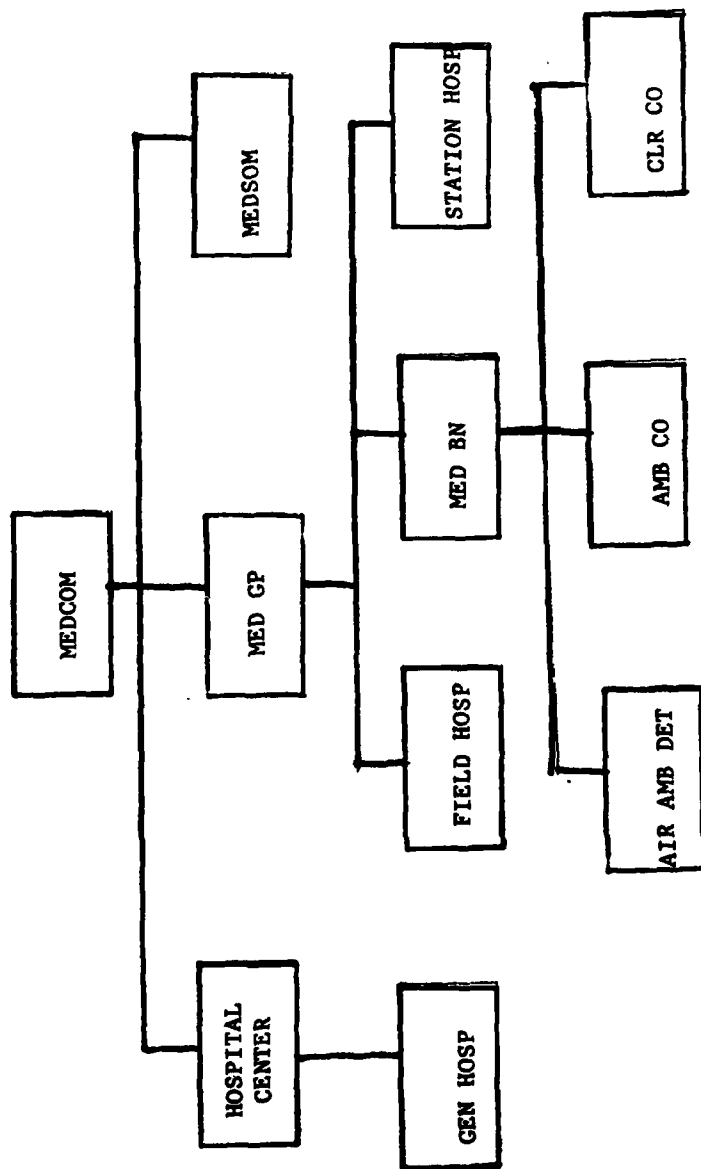

FIGURE 4

CURRENT COMM2 MEDICAL SUPPORT STRUCTURE

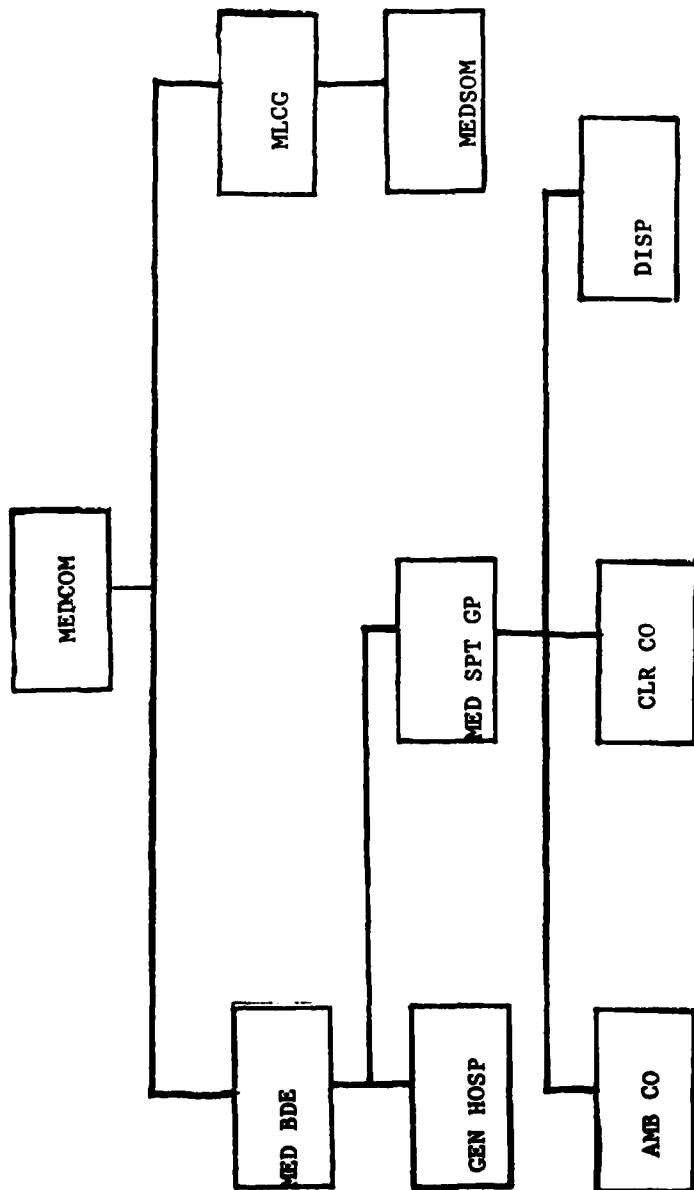

FIGURE 5

PROPOSED COMMZ MEDICAL SUPPORT STRUCTURE

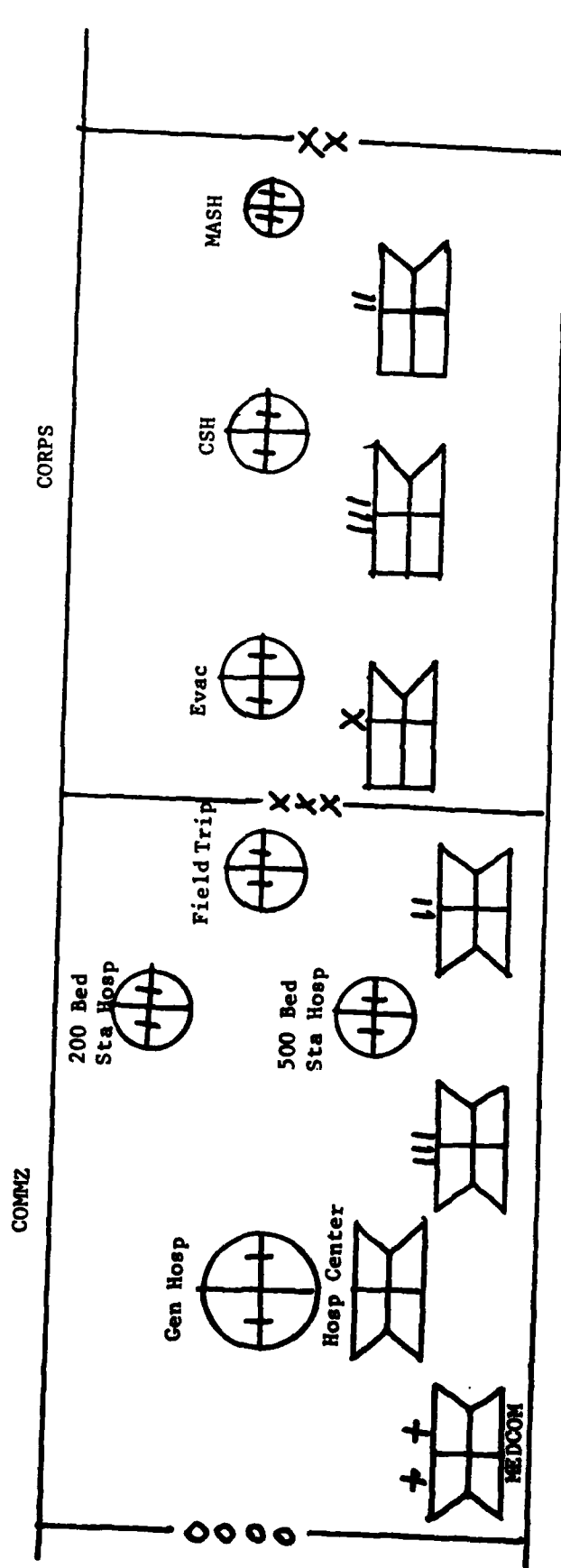

FIGURE 6

CURRENT HOSPITALIZATION AND COMMAND CONTROL FOR THE CORPS AND COMNZ

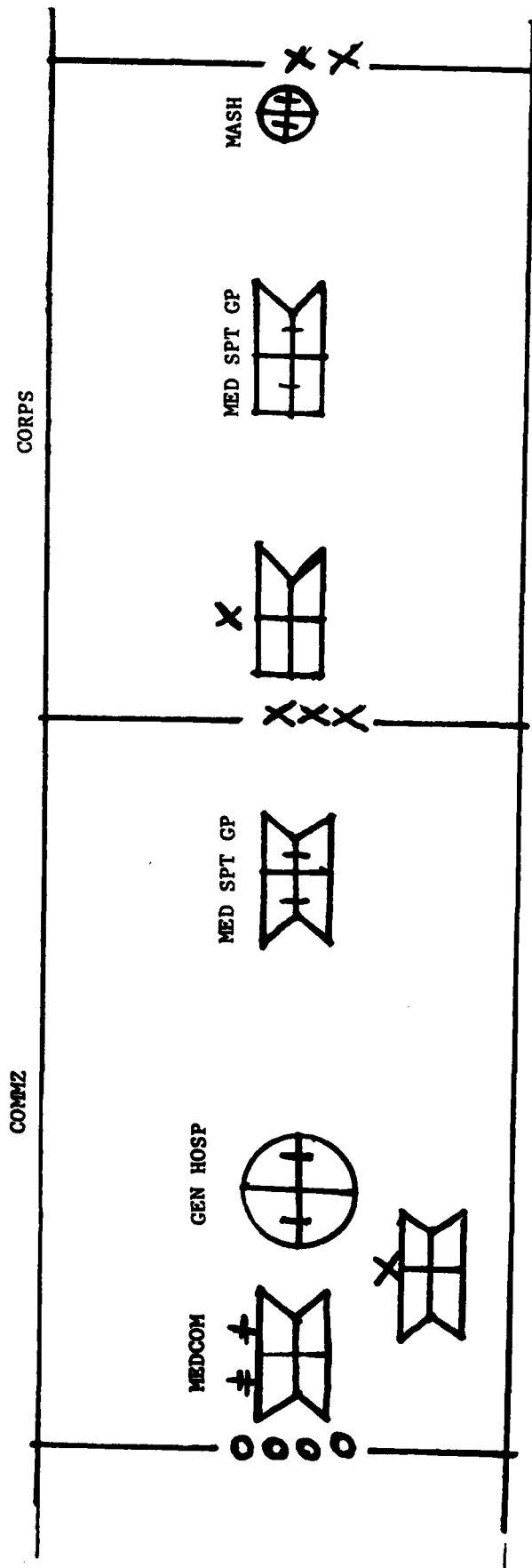

FIGURE 7

PROPOSED HOSPITALIZATION AND COMMAND CONTROL FOR CORPS AND COMMZ

ANNEX 1

HOSPITALIZATION CONCEPT

Hospitalization will be accomplished using modular hospitals that will be referred to medical support groups. These units will provide hospitalization by varying the clinical emphasis and number of beds depending upon requirements of the area (echelon), medical workload, and tactical environment supported. Furthermore, these units will be capable of using existing buildings or mobile shelters.

Medical support groups organized using the above concept would generally conform to the diagram below:

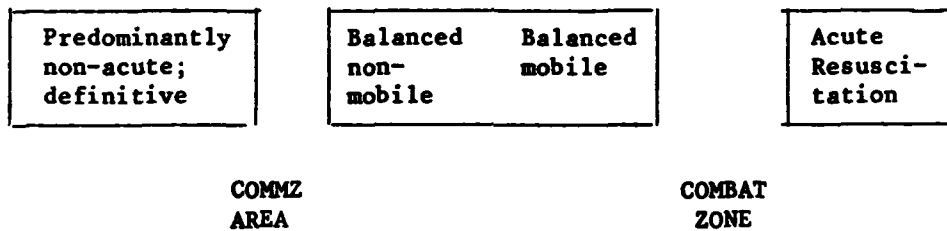

Figure 1

Hospitals in the forward areas of the Combat Zone will normally be more mobile and have acute resuscitation (surgery) as the predominant capability. Hospitals in the corps rear will be balanced (surgical and medical capability) in order to care for patients from the forward areas and patients occurring in the local area. Similar hospitals could be utilized in the forward part of the COMMZ area. These units will have less mobility in their routine employment but could be readily modified to reconstitute corps medical facilities. The hospitals in the rear of the COMMZ will have the capability to maintain the stabilization process and as the theater matures provide definitive and restorative care. Generally, these facilities will be 1,000 bed general hospitals and have very limited mobility.

Concept of employing the support group in the corps area is depicted in Figure 2 and the concept of employing support group in the COMMZ Theater Support Area is shown in Figure 3.

ANNEX 2

EVACUATION CONCEPT

Within a theater of operations, patients may be evacuated by individual carries, litter teams, ground ambulances, aircraft, watercraft, or any combination. Regardless of the means used, patient evacuation under most battlefield conditions is a difficult, hazardous task. It becomes even more complex with problems created by bad weather, high altitude, inaccessibility to available roads, broken or rough terrain, movement of other friendly elements, and enemy actions. Coordination of evacuation plans with those involving the flow of tactical and logistical traffic to and from the main battle area is essential to sound patient evacuation operations.

To the maximum extent feasible, air ambulances will be used in the combat zone for the evacuation of patients. Various ground ambulances will also be used to evacuate patients. The specific mode of evacuation is determined by availability of aircraft, the tactical situation, climatic conditions, etc. When both air and ground ambulances are used, specific factors are considered in determining which patients are to be evacuated by air and which ones are to be evacuated by ground ambulances. Normally, the physician treating the patient makes this determination based upon the clinical condition of the patient with primary consideration given to the evacuation means which contributes most to the patient's well-being and least to his morbidity.

ANNEX 3

TRIAGE CONCEPT (FM 8-10)

Sorting (triage) of mass casualties means the evaluation and categorization of casualties for treatment and evacuation to facilitate the intelligent use of available resources and thus insure the greatest good for the greatest number. Sorting of mass casualties is no different from normal patient sorting except for the application of a contingency set of criteria keyed to solving the clinical problems which are present. Sorting is accomplished by the medical personnel best qualified to make sound clinical judgments promptly. Medical officers identify each patient by a category title which indicates the urgency of his receiving treatment and likelihood of his survival based upon the clinical problems. This rapid sorting assures that the available treatment is directed first toward the patients who have the best chance to survive rather than dissipated ineffectively.

The categories are:

- Minimal - Category for the patient whose condition is such that simple procedures will suffice and enable him to be returned to some form of duty. Follow-on treatment may be needed after the disparity phase is terminated. (Approximately 40 percent of the casualties are normally in this category.)

- Immediate - Category for the patient whose condition demands immediate, resuscitative treatment. This category has the highest priority for treatment. Generally, the procedures used are short in duration and economical in terms of medical resources. (Approximately 20 percent of the casualties are normally in this category.)

- Delayed - Category for the patient whose condition is such that, with the application of modest emergency procedures, the possibility of morbidity

or mortality increases very little by delaying major definitive procedures until they can be performed under more ideal circumstances. (Approximately 20 percent of the casualties are normally in this category.)

● Expectant - Category for the patient whose injuries are so massive that the probability of his survival is minuscule, even if the total medical resources were to be concentrated upon him. The objective to provide the greatest good for the greatest number during the period of medical disparity dictates that medical personnel manage this category of patients with an attitude of alertness (expectancy) to changes in the patients' conditions and provide them symptomatic and supportive care until such time as the medical workload permits a more intensive effort in their behalf. (Approximately 20 percent of the casualties are normally in this category.)

ANNEX 4

TERMS AND DEFINITIONS (FM 8-10)

• **Emergency Medical Treatment** - In the emergency medical treatment phase, medical skill and judgment of a high degree are applied. The medical treatment is provided in a relatively safe environment with time to accomplish a more complete examination and start an adequate plan of treatment. Treatment includes the use of intravenous fluids and antibiotics; the preservation of the patient's airway by surgical procedures, if necessary; and the application of more secure splints and bandages. These comprehensive elements of medical management make it possible for the patient to be transported for the level of treatment demanded by the nature of his condition. For those patients who cannot be returned to duty, the final step is to arrange for the proper means of evacuation. This phase of treatment is characteristic of a unit aid station's capabilities.

• **Initial Resuscitative Treatment** - The initial resuscitative treatment phase is distinguished by the application of clinical judgment and skill of a team of physicians and a dentist. This team is supported by a staff, basic laboratory capability, broad range of medicinal drugs, equipment and supplies, intravenous fluids to include whole blood, and a holding ward capability where the necessary examinations and observations can be accomplished in a deliberate manner. For those patients who must be evacuated for a more comprehensive scope of treatment, arrangements are made for evacuation by ground to air to the particular combat zone hospital which can provide the required treatment. This phase of care is characteristic of a division clearing station's capabilities.

• **Resuscitative Treatment** - The resuscitative treatment phase is for patients whose conditions require very comprehensive, preoperative diagnostic procedures, intensive preparation for surgery, the presence of qualified surgical

teams, the capability to administer general anesthesia, provision for properly equipped operating rooms, and an adequate post-operative intensive care environment. The objective of this phase of treatment is to perform those emergency surgical procedures which, in themselves, constitute resuscitation and without which death or serious loss of limb or body function is inevitable. This phase of treatment is normally provided only in a hospital.

• Definitive Treatment - The definitive treatment phase is particularly adapted to the precise condition of the patient. It embraces those endeavors which complete the recovery of the patient. Specific procedures are executed by specialists. Definitive treatment, not hampered by the crisis aspect as in resuscitative care, proceeds with a greater degree of deliberation and preparation. Its completion represents the maximum of recovery and preservation of limb and function. For the majority of patients, definitive treatment constitutes all that is needed for them to return to full and useful duty. This scope of treatment requires the type of clinical capability found only in a hospital properly staffed and equipped and located in an environment with a low level of threat from enemy action. Definitive treatment is provided at hospitals located to the rear of the combat zone and at hospitals in the theater support area.

• Restorative Treatment - The restorative treatment phase is to return the patient to health and includes partial or complete reconstruction of a body part or the device used as its replacement. This phase of treatment is provided in hospitals in the theater support area of a mature theater.

ANNEX 5

BIBLIOGRAPHY/REFERENCES

US Department of the Army: Health Service Support Theater of Operations.
Field Manual, 8-10 Washington, DC; US Government Printing Office, 1978.

US Department of the Army: Health Service Support Communications Zone.
Field Manual, 8-21 (DRAFT), Fort Sam Houston, TX 1979.

US Department of the Army: Operations. Field Manual, 100-5; US Government
Printing Office, 1979.

US Department of the Army: Operations: EAC. Field Manual; 100-16 (DRAFT)
1981.

US Department of the Army: Combat Service Support in Battle. Circular,
100-10 (DRAFT) Fort Lee, VA 1978.

US Department of the Army: Medical Support to Divisions, Separate Brigades
and the Armored Cavalry Regiment. Field Manual, 8-15 US Government Printing
Office, 1972.

US Department of the Army: Evacuation of Sick and Wounded. Field Manual,
8-35, US Government Printing Office, 1977.

US Department of the Army: Army Medical Service Planning Guide. Field
Manual, 8-55, US Government Printing Office, 1960.

US Department of the Army: CW/NBC Defense Program Master Plan (CHEM-MAP 90),
Part 1, Study, United States Army Nuclear Chemical Agency, Springfield, VA,
1979.

US Department of the Army: Nuclear Systems Program Review, US Army
Artillery Center, Fort Sill, OK, December, 1979.

US Department of the Army: Administrative/Logistics Systems Program
Review, US Army Logistics Center, Fort Lee, VA, February, 1980.

US Department of the Army: Chemical Systems Program Review, US Army
Chemical Center, Fort McClellan, AL, Programmed for May, 1980.

US Department of the Army: Vietnam Studies, Medical Support 1965-1970.
Major General Spurgeon Neel, US Government Printing Office, 1974.

US Department of the Army, The Surgeon General: Battle Casualties and
Medical Statistics, US Army Experience in the Korean War. Frank A. Reister,
1973.

ATE
LME
-8