

AD-A116281

TR-01-022

AFAMRL-TR-81-151



**USER'S GUIDE FOR COMBIMAN PROGRAMS  
(COMputerized Blomechanical MAN-Model)  
VERSION 5**

*P. BAPU  
P. KIKTA  
M. KORNA*

*UNIVERSITY OF DAYTON RESEARCH INSTITUTE  
300 COLLEGE PARK AVENUE  
DAYTON, OHIO 45469*

*J. McDANIEL  
AIR FORCE AEROSPACE MEDICAL RESEARCH LABORATORY*

APRIL 1982

Approved for public release; distribution unlimited

20081202 326

AIR FORCE AEROSPACE MEDICAL RESEARCH LABORATORY  
AEROSPACE MEDICAL DIVISION  
AIR FORCE SYSTEMS COMMAND  
WRIGHT-PATTERSON AIR FORCE BASE, OHIO 45433

## NOTICES

When US Government drawings, specifications, or other data are used for any purpose other than a definitely related Government procurement operation, the Government thereby incurs no responsibility nor any obligation whatsoever, and the fact that the Government may have formulated, furnished, or in any way supplied the said drawings, specifications, or other data, is not to be regarded by implication or otherwise, as in any manner licensing the holder or any other person or corporation, or conveying any rights or permission to manufacture, use, or sell any patented invention that may in any way be related thereto.

Please do not request copies of this report from Air Force Aerospace Medical Research Laboratory. Additional copies may be purchased from:

National Technical Information Service  
5285 Port Royal Road  
Springfield, Virginia 22161

Federal Government agencies and their contractors registered with Defense Technical Information Center should direct requests for copies of this report to:

Defense Technical Information Center  
Cameron Station  
Alexandria, Virginia 22314

### TECHNICAL REVIEW AND APPROVAL

AFAMRL-TR-81-151

This report has been reviewed by the Office of Public Affairs (PA) and is releasable to the National Technical Information Service (NTIS). At NTIS, it will be available to the general public, including foreign nations.

This technical report has been reviewed and is approved for publication.

**FOR THE COMMANDER**

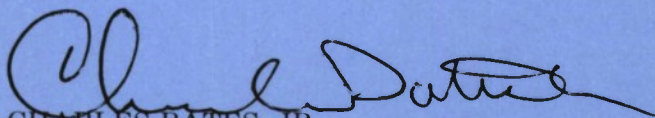

CHARLES BATES, JR.  
Chief  
Human Engineering Division  
Air Force Aerospace Medical Research Laboratory

REPORT DOCUMENTATION PAGE		READ INSTRUCTIONS BEFORE COMPLETING FORM
1. REPORT NUMBER AFAMRL-TR-81-151	2. GOVT ACCESSION NO.	3. RECIPIENT'S CATALOG NUMBER
4. TITLE (and Subtitle) USER'S GUIDE FOR COMBIMAN PROGRAMS (COMputerized BIomechanical MAN-Model) VERSION 5		5. TYPE OF REPORT & PERIOD COVERED Technical Interim Report
		6. PERFORMING ORG. REPORT NUMBER UDR-TR-81-80
7. AUTHOR(s) P. Bapu                      J. McDaniel* P. Kikta M. Korna		8. CONTRACT OR GRANT NUMBER(s)  F33615-78-C-0507
9. PERFORMING ORGANIZATION NAME AND ADDRESS University of Dayton Research Institute 300 College Park Avenue Dayton, Ohio 45469		10. PROGRAM ELEMENT, PROJECT, TASK AREA & WORK UNIT NUMBERS  62202F, 7184-08-24
11. CONTROLLING OFFICE NAME AND ADDRESS Air Force Aerospace Medical Research Lab., Aerospace Medical Division (AFSC) Wright-Patterson AFB, Ohio 45433		12. REPORT DATE April 1982
		13. NUMBER OF PAGES 348
14. MONITORING AGENCY NAME & ADDRESS (if different from Controlling Office)		15. SECURITY CLASS. (of this report)  Unclassified
		15a. DECLASSIFICATION/DOWNGRADING SCHEDULE
16. DISTRIBUTION STATEMENT (of this Report)  Approved for public release; distribution unlimited		
17. DISTRIBUTION STATEMENT (of the abstract entered in Block 20, if different from Report)		
18. SUPPLEMENTARY NOTES  *Workload and Ergonomics Branch Human Engineering Division Air Force Aerospace Medical Research Laboratory		
19. KEY WORDS (Continue on reverse side if necessary and identify by block number)		
Three Dimensional Anthropometric Man-Model Crew Station Design and Evaluation Computer Simulation Interactive Graphics Program Functions		Data Bases Reach Analysis Perspective View Visibility Plot Zoom
20. ABSTRACT (Continue on reverse side if necessary and identify by block number)  This User's Guide describes the procedures to operate the Air Force Aerospace Medical Research Laboratory's (AFAMRL) COMputerized BIomechanical MAN-model (COMBIMAN) programs. The Guide is based on the programs as of 1 May 1981. The Guide includes an introduction to the man-model and the conventions used to develop and analyze crew station configurations. It also deals with the operations of the operations of the programs included in the COMBIMAN system.		

Block 20. - Abstract (Continued)

These programs include the interactive graphics program CBM05, and the three key file creation/modification programs CBMAM, CBMCM, and CBMVM, which create and maintain the Data Bases of anthropometric surveys, crew station configurations, and visibility contour definitions respectively. The guide also contains a complete description of the use of CBMOFF, the off-line plot program.

The guide to operate the four main programs includes descriptions of the available processing for each program, definitions and examples of all input and output data formats, procedures to load the programs, and explanations of all diagnostic messages generated by the programs.

## SUMMARY

This User's Guide describes the procedures to operate the Air Force Aerospace Medical Research Laboratory's (AFAMRL) COMputerized BIomechanical MAN-model (COMBIMAN) programs. The Guide is based on the COMBIMAN system of programs as of 1 May 1981. An introduction to the man-model and the conventions used to develop and analyze crew station configurations are included in the guide. It also contains the operations of the programs included in the COMBIMAN system. These programs include the interactive graphics program CBM05 to generate COMBIMAN, and the three key file creation/modification programs CBMAM, CBMCM, and CBMVM, which create and maintain the Data Bases of anthropometric surveys, crew station configurations, and visibility contour definitions respectively. The guide also contains a complete description of the use of the off-line plot program, CBMOFF. The first four programs are designed to run on an IBM 370 computer and CBMOFF is designed to run on a CDC Computer.

The guide to operate the four main programs includes descriptions of the available processing for each program, definitions and examples of all input and output data formats, procedures to load the programs, and explanations of all diagnostic messages generated by the programs. The requirements to run CBM05 and the available functions on the COMBIMAN are also described in the guide.

## PREFACE

This work was performed under USAF Contract F33615-78-C-0507 entitled Biomechanics of Cockpit Evaluation. The government work unit number for this contract is 71840824. The contract monitor and technical advisor is Dr. Joe W. McDaniel of the Workload and Ergonomics Branch of the Air Force Aerospace Medical Research Laboratory. The development of the programs referred to in this User's Guide was performed by the University of Dayton Research Institute (UDRI). The UDRI Technical Report number for this Guide is UDR-TR-81-80.

The purpose of this report is to provide a detailed guide to use the key computer programs of the AFAMRL COMBIMAN system. It does not document the theoretical approach taken in developing any of the computer programs. The manipulation of the model and crew station is straightforward and the information in Section 2 will enable a non-computer person to run the interactive graphics program CBM05. Because of the technical nature of the plot program described in Section 3, and the data base maintenance programs described in Sections 4, 5, and 6, the person assigned to interpret and to use these programs should possess some experience in computer programming. Since all the programs are considered relevant to the COMBIMAN system, they are all included in this guide for sake of completeness. The description of the man-model and crew station in the introduction are presented as general background material needed to use the programs efficiently. The link-system described in the introduction is based on research originally performed by W. T. Dempster of the University of Michigan. Dr. K. W. Kennedy of AFAMRL/HEG contributed to the definition of the Anthropometric Data Base and provided significant improvements to the Dempster man-model link systems.

The authors would like to acknowledge the assistance and the technical support provided by Dr. Kenneth W. Kennedy and Mr. Charles Clauser of the Workload and Ergonomics Branch of the AFAMRL. In addition, the authors would like to thank Mr. John T. Moy of UDRI for programming effort and critical review and Ms. Charlene Thompson of UDRI for her patience while typing this User's Guide.

## TABLE OF CONTENTS

Section		Page
1	INTRODUCTION	17
	1.1 MAN-MODEL GENERATION	18
	1.2 CREW STATION DESIGN	22
	1.3 EVALUATION TECHNIQUES	24
	1.4 THE COMBIMAN PROGRAMS	25
2	THE COMBIMAN INTERACTIVE GRAPHICS PROGRAM - VERSION 5 - CBM05	31
	2.1 INTRODUCTION	31
	2.1.1 Available Functions	35
	2.1.2 Requirements	37
	2.2 AVAILABLE PROCESSING	37
	2.2.1 CHANGE VIEW Function (PFK0)	41
	2.2.2 IDENTIFY OBJECT Function (PFK1)	45
	2.2.3 OMIT OBJECT Function (PFK2)	48
	2.2.4 INCLUDE OBJECT Function (PFK3)	51
	2.2.5 RETRIEVE ANTHROPOMETRY Function (PFK4)	52
	2.2.6 RETRIEVE CREW STATION Function (PFK5)	56
	2.2.7 VISIBILITY PLOT Function (PFK6)	59
	2.2.8 OFF-LINE PLOT COMBIMAN Function (PFK7)	65
	2.2.9 ON-LINE PLOT COMBIMAN Function (PFK8)	70
	2.2.10 PRINT DATA Function (PFK9)	72
	2.2.11 PERFORM REACH ANALYSIS Function (PFK11)	74
	2.2.11.1 Positioning the Cross Symbol "+"	78
	2.2.11.2 Post Reach Processing	84
	2.2.12 INPUT 12 ANTHROPOMETRIC DIMENSIONS Function (PFK12)	88
	2.2.13 INPUT TWO INDEPENDENT VARIABLES Function (PFK13)	98
	2.2.14 DISPLAY TABLE Function (PFK14)	108
	2.2.15 DUMP CRT Function (PFK15)	113

TABLE OF CONTENTS (Continued)

Section		Page
	2.2.16 DESIGN PANEL Function (PFK16)	115
	2.2.17 DELETE PANEL Function (PFK18)	117
	2.2.18 CHANGE PERSPECTIVE Function (PFK22)	118
	2.2.19 RESET SLUMPED POSTURE Function (PFK23)	121
	2.2.20 RESET ERECT POSTURE Function (PFK24)	123
	2.2.21 RESET PROGRAMMED POSTURE Function (PFK25)	125
	2.2.22 INCREMENT ROLL, PITCH AND YAW ANGLE Function (PFK26)	127
	2.2.23 SEAT ADJUST Function (PFK27)	129
	2.2.24 ZOOM Function (PFK28)	131
	2.2.25 STATE SWITCH Function (PFK29)	137
	2.2.26 RESTART PROGRAM Function (PFK30)	143
	2.2.27 END PROGRAM Function (PFK31)	144
2.3	EXECUTING THE JOB	146
	2.3.1 Loading the Program CBM05	146
	2.3.2 Error Procedures	146
	2.3.3 Ending the Program CBM05	149
2.4	PROGRAM MESSAGES-INFORMATION AND ERROR TYPE	151
3	OFF-LINE PLOT PROGRAM (CBMOFF)	159
	3.1 AVAILABLE PROCESSING	159
	3.2 PROGRAM MESSAGES - INFORMATION AND ERROR TYPE	166
4	COMBIMAN ANTHROPOMETRIC DATA BASE MAINTENANCE PROGRAM (CBMAM)	169
	4.1 AVAILABLE PROCESSING	169
	4.2 RESTRICTIONS AND LIMITATIONS	171
	4.3 HOW TO USE PROGRAM CBMAM	171
	4.3.1 Input Data Specification	172
	4.3.2 Processing Specification	179
	4.3.2.1 ADD ANTHROPOMETRIC MEMBER Function	181
	4.3.2.2 TYPE 0 MEMBERS	181
	4.3.2.3 TYPE 1 MEMBERS	189

TABLE OF CONTENTS (Continued)

Section		Page
	4.3.2.4 CHECK ANTHROPOMETRIC MEMBER Function	192
	4.3.2.5 DELETE ANTHROPOMETRIC MEMBER Function	192
	4.3.2.6 COMPRESS ANTHROPOMETRIC DATA BASE Function	193
	4.3.2.7 DUMP ANTHROPOMETRIC MEMBER Function	193
	4.3.2.8 END PROGRAM Function	193
	4.3.2.9 INITIALIZE ANTHROPOMETRIC MEMBER Function	194
	4.3.2.10 PUNCH ANTHROPOMETRIC MEMBER Function	194
	4.3.2.11 PRINT ANTHROPOMETRIC MEMBER Function	194
	4.3.3 Submitting a Processing Request	195
	4.3.4 Output Data Interpretation	195
4.4	PROGRAM MESSAGES INCLUDING ERROR CORRECTION	208
5	COMBIMAN CREW STATION DATA BASE MAINTENANCE PROGRAM (CBMCM)	217
5.1	AVAILABLE PROCESSING PERFORMED	217
5.2	RESTRICTIONS AND LIMITATIONS	219
5.3	HOW TO USE PROGRAM CBMCM	219
	5.3.1 Input Data Specification	219
	5.3.2 Processing Specification	226
	5.3.2.1 ADD CREW STATION MEMBER Function	226
	5.3.2.2 CHECK CREW STATION MEMBER Function	230
	5.3.2.3 DELETE CREW STATION MEMBER Function	230
	5.3.2.4 COMPRESS CREW STATION DATA BASE Function	232
	5.3.2.5 DUMP CREW STATION MEMBER Function	232
	5.3.2.6 END PROGRAM Function	232
	5.3.2.7 INITIALIZE CREW STATION DATA BASE Function	233

TABLE OF CONTENTS (Continued)

Section		Page
	5.3.2.8 PUNCH CREW STATION MEMBER Function	233
	5.3.2.9 PRINT CREW STATION MEMBER Function	233
	5.3.3 Submitting a Processing Request	233
	5.3.4 Output Data Interpretation	235
5.4	PROGRAM MESSAGES - INCLUDING ERROR CORRECTION	243
6	COMBIMAN VISIBILITY DATA BASE MAINTENANCE PROGRAM (CBMVM)	251
6.1	AVAILABLE PROCESSING	251
6.2	RESTRICTIONS AND LIMITATIONS	253
6.3	HOW TO USE CBMVM	253
	6.3.1 Input Data Specification	253
	6.3.2 Processing Specification	255
	6.3.2.1 ADD VISIBILITY MEMBER Function	255
	6.3.2.2 CHECK VISIBILITY MEMBER Function	259
	6.3.2.3 DELETE VISIBILITY MEMBER Function	259
	6.3.2.4 COMPRESS VISIBILITY DATA BASE Function	259
	6.3.2.5 DUMP VISIBILITY MEMBER Function	260
	6.3.2.6 PRINT VISIBILITY MEMBER Function	260
	6.3.2.7 INITIALIZE VISIBILITY MEMBER Function	261
	6.3.2.8 END PROGRAM Function	261
	6.3.3 Submitting a Processing Request	261
	6.3.4 Output Data Interpretation	261
6.4	PROGRAM MESSAGES - INCLUDING ERROR CORRECTION	267

TABLE OF CONTENTS (Continued)

Section	Page
APPENDIX A: COMBIMAN DISTRIBUTION TAPE DOCUMENTATION	274
APPENDIX B-1: LINKAGE EDITOR MAP OF CBM05	277
APPENDIX B-2: LINKAGE EDITOR MAP OF CBMAM	282
APPENDIX B-3: LINKAGE EDITOR MAP OF CBMCM	284
APPENDIX B-4: LINKAGE EDITOR MAP OF CBMVM	286
APPENDIX C-1: COMBIMAN SOURCE - CBMCP2 LISTING	288
APPENDIX C-2: COMBIMAN SOURCE - CBMCP3 LISTING	291
APPENDIX C-3: COMBIMAN SOURCE - CBMCP4 LISTING	293
APPENDIX C-4: COMBIMAN SOURCE - CBMVSI LISTING	296
APPENDIX C-5: COMBIMAN SOURCE - CBMOFF LISTING	301
APPENDIX C-6: COMBIMAN SOURCE - CBMCM LISTING	307
APPENDIX C-7: COMBIMAN SOURCE - IBMGLD LISTING	321
APPENDIX D: JCL AND DATA REQUIRED TO CREATE 67 USAF AND 70 ARMY SURVEY MEMBERS AND R67 USAF AND R70 ARMY REGRESSION MEMBERS OF THE COMBIMAN ANTHROPOMETRIC DATA BASE	329
APPENDIX E: JCL AND DATA REQUIRED TO CREATE THE COMBIMAN CREW STATION DATA BASE MEMBER A7E-01 AND A7-SEAT	337
APPENDIX F: THE JCL AND DATA REQUIRED TO CREATE THE COMBIMAN VISIBILITY DATA BASE MEMBER A7E-01	340
REFERENCES	343

## LIST OF ILLUSTRATIONS

Figure		Page
1	COMBIMAN Link System - Side View.	19
2	COMBIMAN Link System with Enfleshment Ellipses.	20
3	Enfleshed COMBIMAN with Tangent Lines.	21
4	COMBIMAN CRT Display with Man-Model and Simplified Crew Station Rotated OFF-AXIS.	23
5	Data Flow in the COMBIMAN Program.	26
6	Format of IBM 2250-3 Display Unit.	32
7	CRT Unit with Function Keys, Alphanumeric Keyboard and Light Pen.	34
8	Functions Available to COMBIMAN User.	36
9	Program Function Keyboard (PFK) Overlay for Program CBM05	38
10	Function Sequence for Generating the Man-Model.	40
11	Top View (X-Y Plane) of the Man-Model and a Crew Station.	42
12	Side View (X-Z Plane) of the Man-Model and a Crew Station.	43
13	Front View (Y-Z Plane) of the Man-Model and a Crew Station.	44
14	The IDENTIFY OBJECT Function Performed on the HUDSCRN (Heads Up Display) of the A7E-01 Crew Station.	46
15	The OMIT OBJECT Function Performed on the HUDSCRN (Heads Up Display) of the A7E-01 Crew Station (Name of Light Penned Object is Displayed).	49
16	The OMIT OBJECT Function Performed on the HUDSCRN (Heads Up Display) of the A7E-01 Crew Station.	50
17	Table of Available Regression Member Names - One Member Must Be Selected by Light Penning.	53
18	Table of Survey Member Name (for Regression Member R67 USAF) One Member Must Be Selected by Light Penning.	54

LIST OF ILLUSTRATIONS (Continued)

Figure		Page
19	Table of Available Crew Station Membernames.	57
20	Table of Available Crew Station Member Name Displayed When the Total Number of Panels Exceeds 250.	58
21	VISIBILITY PLOT FUNCTION.	60
22	VISIBILITY PLOT Function.	61
23	Visibility Plot.	62
24	Canopy Outline Coordinates in Aircraft System.	64
25	The Message and a Response for the COMBIMAN PLOT Function.	66
26	ON-LINE PLOT Function.	67
27	ON-LINE PLOT Function.	69
28	ON-LINE PLOT Function.	71
29	Output for COMBIMAN PRINT Function.	73
30	PERFORM REACH ANALYSIS Function.	75
31	PERFORM REACH ANALYSIS Function Light Pen Reach Type.	76
32	PERFORM REACH ANALYSIS Function Light Pen Extent of Reach.	77
33	Positioning Cross Symbol "+" Initially the Cross Symbol is Displayed at the SRP.	79
34	Side View (X-Z Plane) - the "+" Symbol Locates the Reach Point.	80
35	Front View (Y-Z Plane).	81
36	Redefined Program FUNCTION Keys for Positioning the "+" Symbol.	82
37	REACH SUCCESSFUL is Displayed after the Reach is Successfully Performed.	85
38	MISS DISTANCE is Displayed if the Man-Model Could Not Reach the Point.	86

LIST OF ILLUSTRATIONS (Continued)

Figure		Page
39	PERFORM REACH Function Printout Obtained When User Responds "YES" to Message "PRINT REACH DATA? L.P. YES or NO".	87
40	DATA SET - COMBIMAN.SMPLANTH (Card Image).	89
41	INPUT 12 ANTHROPOMETRIC DIMENSIONS Function Option to Change Input Unit When Entering Values in Engineering Units.	91
42	INPUT 12 ANTHROPOMETRIC DIMENSIONS Function Choose New Unit for Input Value.	92
43	INPUT 12 ANTHROPOMETRIC DIMENSIONS Function Sample Input in Engineering Unit.	93
44	INPUT 12 ANTHROPOMETRIC DIMENSIONS Function Choose New Unit, if Necessary, for the Next Input Variable.	94
45	INPUT 12 ANTHROPOMETRIC DIMENSIONS Function Option to Choose Input Values in Percentile or in Engineering Units.	96
46	Light Pen Percentile Values for the INPUT 12 ANTHROPOMETRIC DIMENSIONS Function.	97
47	INPUT TWO INDFEPENDENT VARIABLES Function Input New Z Score (Default Value is 1.65).	99
48	INPUT TWO INDEPENDENT VARIABLES Function Option to Choose Input Values in Percentile or in Engineering Unit.	101
49	INPUT TWO INDEPENDENT VARIABLE Function Light-Pen First Independent Variable.	102
50	INPUT TWO INDEPENDENT VARIABLE Function Light-Pen Second Independent Variable.	103
51	INPUT TWO INDEPENDENT VARIABLE Function Light-Pen Percentile for the Second Independent Variable Within Range.	104
52	DISPLAY TABLE Displays Links, Their Lengths and Euler Angles.	109
53	DISPLAY TABLE Change THETA Value of MH-MEYE from 90° to 110°.	110

LIST OF ILLUSTRATIONS (Continued)

Figure		Page
54	Example of Euler Angle Changes for Elbow Joints.	112
55	DUMP CRT Function.	114
56	Printed Output of the Newly Designed Panel NWPNL is Within the Box.	116
57	PFK's for Change Perspective Function.	119
58	RESET SLUMPED Posture Function.	122
59	RESET ERECT POSTURE Function.	124
60	RESET PROGRAMMED POSTURE Function.	126
61	SEAT ADJUST Function Enter X Coordinate Offset in Inches.	130
62	Define ZOOM Window.	132
63	Define ZOOM Window.	133
64	The Fully Defined ZOOM Window.	134
65	The "ZOOMED" Display.	135
66	Man-Model with Enfleshment Density Code 4 (Default Enfleshment Density Code is 0).	139
67	Surface Dimensions and Internal Link Lengths Calculated by CBM05.	140
68	Printed Output of the Two Selected Independent Variable Values Calculated by CBM05.	141
69	Transformation Equation Developed for Positioning Stomach Link (Set State Switch 72 ON).	142
70	JOB CONTROL CARDS to Execute CBM05.	147
71	Options Displayed on Depressing ALT CODE and CANCEL Keys Together.	150
72	The Format of the Namelist CNTRL.	162
73	The Format of the Data Card for Unwanted Plots.	162
74	COMBIMAN OFF-LINE Plot.	163

LIST OF ILLUSTRATIONS (Continued)

Figure		Page
75	Plot Banner for the Plot Shown in Figure 74.	164
76	Card Input for Figure 74.	165
77	Card Input for Figure 78.	165
78	Altered COMBIMAN OFF-LINE Plot.	167
79	Data Flow for Program CBMAM.	170
80	Sample Data Obtained from Summary Statistics of the Air Force Rated Officers.	176
81	Program CBMAM Control Card Format.	180
82	Example of +ADD Control Card for Type 0 Member.	182
83	Example of +ADD Control Card for Type 1 Member.	182
84	Program CBMAM Regression Member Variable Definition Card.	184
85	Program CBMAM Regression Member Simple Regression Coefficient Definition Card.	184
86	Program CBMAM Regression Member Multiple Regression Coefficient Definition Card.	184
87	Example of Regression, or Type 0 Member.	185
88	Program CBMAM Survey Member Percentile Definition Card.	190
89	Program CBMAM Survey Member Dimension Definition Cards.	190
90	Example of Survey, or Type 1, Member.	191
91	Job Control Cards to Execute CBMAM.	196
92	FT02 DD Card to Allocate Space for COMBIMAN.ANTHDTA and Execute CBMVM.	196
93	A Sample Output of the +CMP Function.	198
94	A Sample Output of the +PRT Function.	200

LIST OF ILLUSTRATIONS (Continued)

Figure		Page
95	A Sample Output of the +DMP Function.	201
96	Output Format Used for Type 0 Regression Data.	203
97	A Sample Output of the +ADD Function for Type 1 Member.	205
98	A Sample Output of the +ADD Function for Type 1 Member.	206
99	A Sample Output of the +ADD Function for Type 0 Member.	207
100	Data Flow for Program CBMCM.	218
101	Sample Crew Station - DESK.	220
102	An Example of a Typical Aircraft Coordinate System and Its Relative COMBIMAN Coordinate System.	222
103	Example of Valid and Invalid Panels.	223
104	X, Y and Z Coordinates of Panels of DESK.	224
105	X, Y and Z Coordinates of Panels of DESK.	225
106	Convention for Determining the Location of a Control in a Panel Relative to its Vertices.	227
107	Program CBMCM Control Card Format.	227
108	Program CBMCM ADD Member Card Format for Panels.	229
109	Program CBMCM ADD Member Card Format for Panels (Continued).	229
110	Program CBMCM ADD Member Card Format for Controls.	229
111	Sample Data for \$ADD Member Function.	231
112	Job Control Cards to Execute Program CBMCM.	234
113	FT01 DD Card to Allocate Space on Disk and Execute Program CBMCM.	234
114	A Sample Output of the \$CMP Function.	237

LIST OF ILLUSTRATIONS (Continued)

Figure		Page
115	A Sample Output of the \$PRT (No Membername) Function.	237
116	A Sample Output of the \$DMP Function.	239
117	Example of Program CBMCM \$ADD (Membername) Function Output Format.	242
118	A Sample Output the \$PRT Function.	244
119	Data Flow for Program CBMVM.	252
120	X, Y and Z Coordinates of A7E-01 Boundaries.	254
121	Program CBMVM Control Card Format.	256
122	Program CBMVM Member Card Format for Panels.	256
123	Program CBMVM Member Card Format for Coordinates of Panels.	256
124	Sample Data for \$ADD Member Function.	258
125	Job Control Cards to Execute CBMVM.	262
126	FT09001 DD Card to Allocate Space for COMBIMAN.VISDATA and Execute Program CBMVM.	262
127	A Sample Output of \$CMP Function.	264
128	A Sample Output of \$PRT Function.	264
129	A Sample Output of \$DMP Function.	266
130	A Sample Output of CBMVM &ADD Function.	268
131	A Sample Output of CBMVM &PRT Function.	269

## LIST OF TABLES

Table	Page
1 PROGRAM MESSAGES AND USER RESPONSES FOR PFK13 WHEN TWO ANTHROPOMETRIC VARIABLES VALUES WILL BE INPUT AS PERCENTILES	105
2 PROGRAM MESSAGES AND USER RESPONSES WHEN TWO ANTHROPOMETRIC VARIABLES VALUES WILL BE INPUT AS ABSOLUTE DIMENSIONS	107
3 LINK SYSTEM DEFINITION	111
4 USER ACTIVATED STATE SWITCHES	138
5 LIST OF DEPENDENT ANTHROPOMETRIC VARIABLES NEEDED TO GENERATE COMBIMAN LINK SYSTEM	173
6 LIST OF DEPENDENT ANTHROPOMETRIC VARIABLE PREDICTORS	173
7 LIST OF ANTHROPOMETRIC DIMENSIONS AVAILABLE IN THE ANTHROPOMETRIC DATA BASE	175
8 MATRIX OF CORRELATION COEFFICIENTS BETWEEN MASS AND LENGTH RELATED ANTHROPOMETRIC VARIABLES (CHURCHILL, ET AL., 1976)	177
9 DEPENDENT AND INDEPENDENT ANTHROPOMETRIC VARIABLES (CHURCHILL, ET AL., 1976)	178

## SECTION 1

### INTRODUCTION

During the design and analysis phases of crew station development, it is essential to assess the inadequacies and dangers of the crew station environment with respect to the human operator. The conventional method for accomplishing this has been to build mock-ups and use an undetermined number of "representative" test pilots to evaluate the work environment and control placement. The mock-ups tend to be costly and time consuming to build, as well as somewhat inflexible during testing. The sample size of the "representative" pilots depends on the availability of pilots and the whims of the designers.

The COMputerized BIomechanical MAN-model (COMBIMAN) system of programs has been developed to assist in the design and analysis phases of crew station development. It has been designed to serve as an interactive-computer-graphics-assisted engineering tool to represent geometric and physical properties of a person at a crew station. It has applications in evaluating conceptual or existing crew stations. The COMBIMAN is a three-dimensional man-model and can be viewed from any plane or angle. Since the man-model and crew station exist only on the Cathode Ray Tube (CRT) and in computer memory, no significant amount of time or materials are invested in making modifications. Alternative designs may be thoroughly evaluated and permanently recorded by a pictorial plot or a tabular printout of the crew station data and man-model (Joe McDaniel, 1974). Because of these capabilities, the COMBIMAN should reduce or eliminate the need for building mock-ups, as the designer can construct a crew station in three dimensions on a CRT and can assess interactions using man-models of various body sizes and proportions.

## 1.1 MAN-MODEL GENERATION

The man-model used in COMBIMAN is based on a 35 link-skeletal system. These links connect major points of rotation of the body segments as shown in Figure 1. The lengths of the links as well as their orientations with respect to their adjacent links in the skeletal system can be modified by the user. Since the segment lengths or link-lengths are generally internal dimensions and are difficult to measure on live subjects, the link lengths are derived from 12 readily measurable anthropometric surface dimensions. The sets of anthropometric variables available to users are highly correlated to mass or length of body segments. A more detailed description of these variables is given in Section 3. Section 2 describes the ways the user can change the proportions of the man-model by specifying new values for the surface dimensions.

There are three stages in generating the man-model. In the first stage, the link system is defined and generated using data available from the Anthropometric Data Base and/or from data supplied by the user (see Figure 1). The other two stages use data supplied in stage one and data stored in the computer. The second stage places enmeshment ellipsoids about the link system joints as shown in Figure 2. In the third stage, the ellipses are connected with tangent lines to define the contour of the man-model (see Figure 3). The user does not see these stages of model development; only the completed man-model is displayed.

The primary viewing planes for COMBIMAN are the X-Z plane (side view), the X-Y plane (top view) and the Y-Z plane (front view). The man-model need not be parallel to any one of these three orthogonal planes; it can be rotated by an angle with respect to these planes. Figures 1, 2, and 3 show COMBIMAN in the X-Z plane (side view).

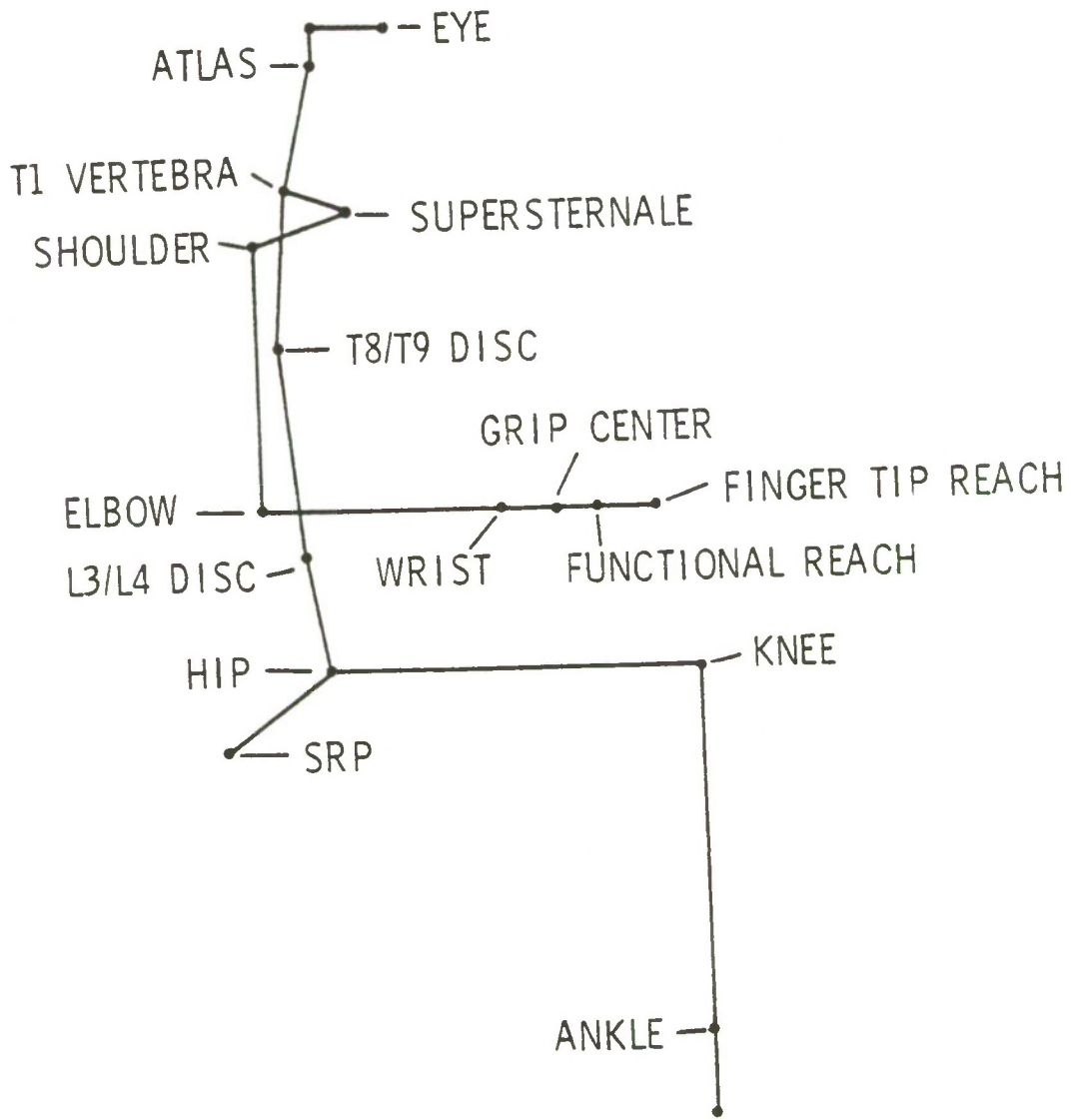

Figure 1. COMBIMAN Link System - Side View.

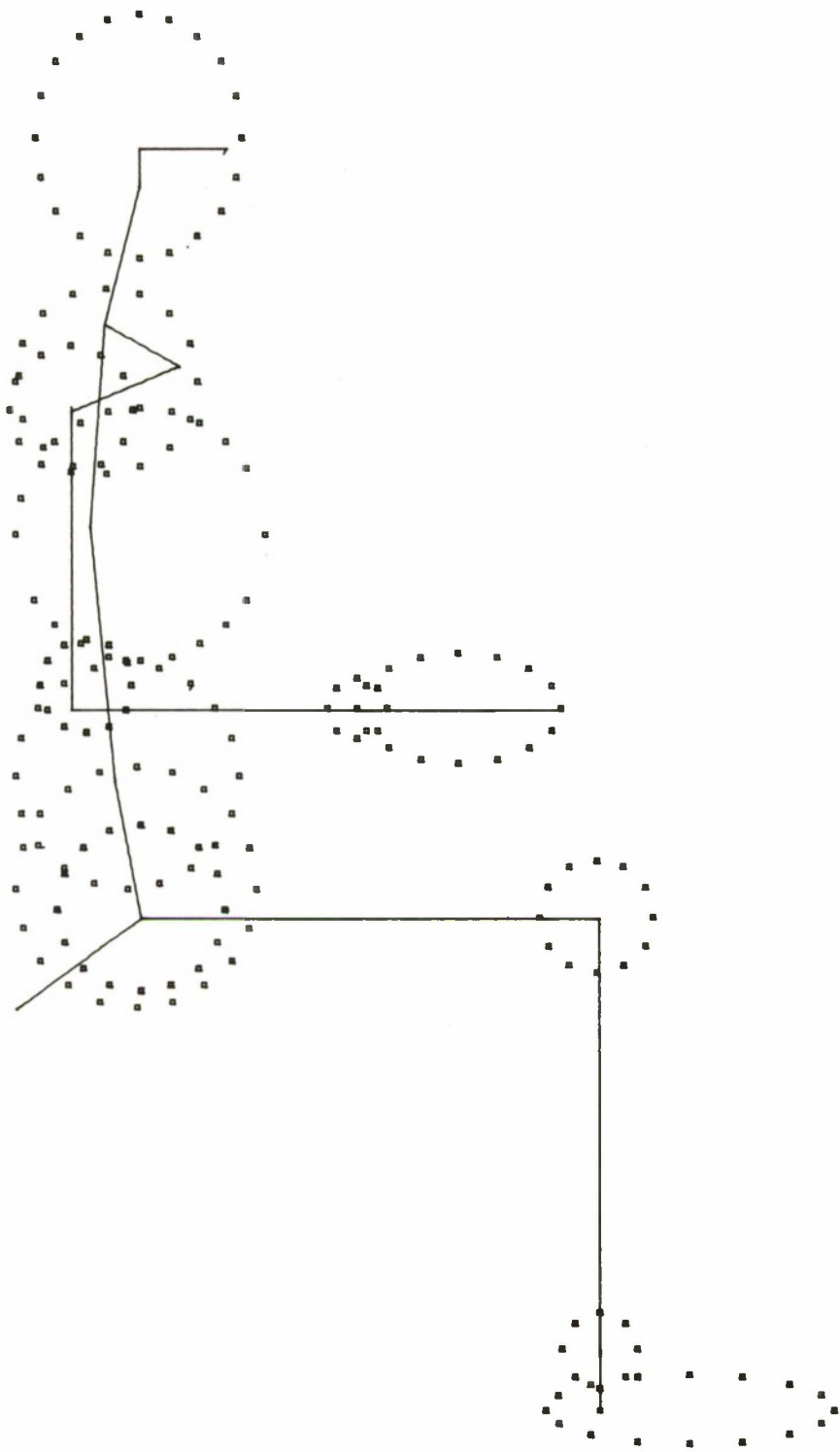

Figure 2. COMBIMAN Link System with Enfleshment Ellipses.

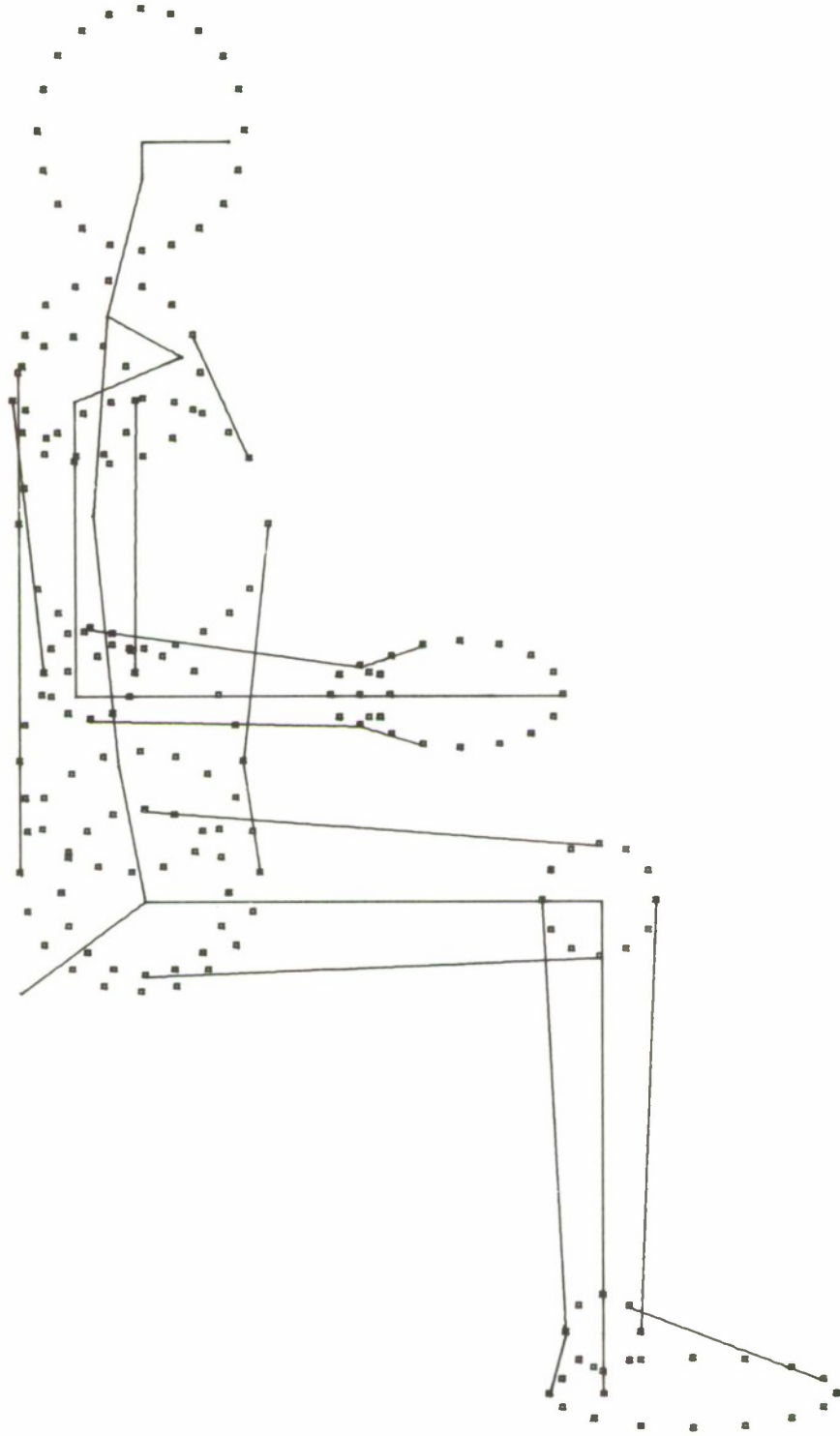

Figure 3. Enfleshed COMBIMAN with Tangent Lines.

## 1.2 CREW STATION DESIGN

Crew stations to be designed and evaluated using the COMBIMAN system consist of panels and controls. A crew station may have up to 250 planar panels with three to six vertices and 150 controls which may or may not be located on defined panels. Although the crew stations used in COMBIMAN are usually aircraft crew stations, it is possible to construct and display any workspace requiring interaction by a seated operator. This would include automobile instrument panels, industrial configurations, and control panels for other types of vehicles.

Two methods are used to generate and display crew stations. The designer can either use an existing or conceptual configuration, or can construct a new one on the Cathode Ray Tube using the available interactive graphic options. In the first method panels and controls for existing or conceptual configuration, are coded onto computer cards, or magnetic tape, or direct access disk, and are entered into the Crew Station Data Base. These data are accessed by the user through the interactive graphics program. In the second method, the user can design crew stations on the CRT, using alphanumeric keyboard and the program function keys, following the basic series of steps similar to those used on a drawing board.

A crew station entered into the program exists in three dimensions and the man-model can interact with it. Since the CRT has only two dimensions, the 3-D man-model and crew station are projected on the screen in the orientation selected by the user. The display can then be rotated within the Display Area to suit the designers' needs. An example of the display with a rotated man-model and crew station are shown in Figure 4. Note that the Roll, Pitch, and Yaw angles are displayed at the upper right hand corner of the display area.

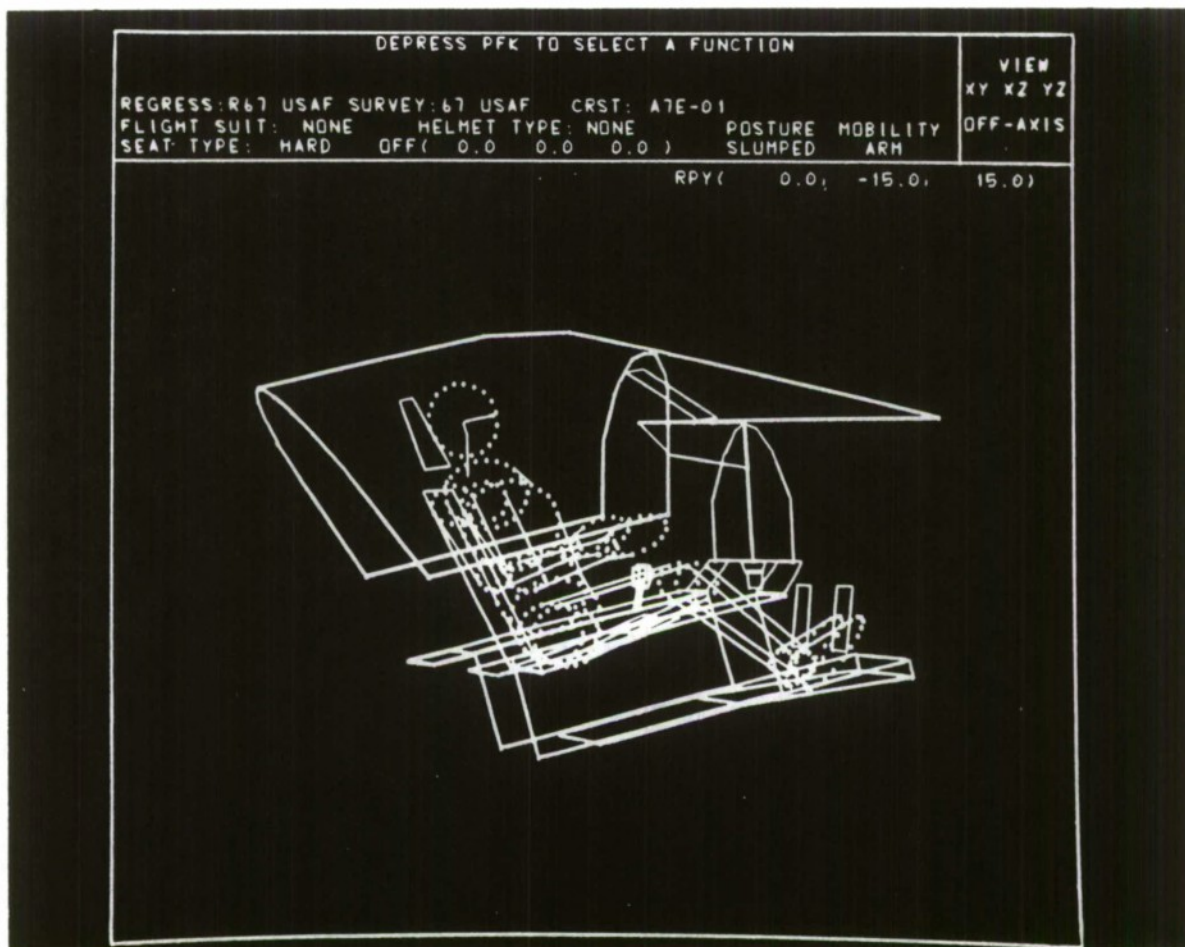

Figure 4. COMBIMAN CRT Display with Man-Model and Simplified Crew Station Rotated OFF-AXIS.

### 1.3 EVALUATION TECHNIQUES

A number of evaluation techniques have been implemented into the COMBIMAN system. They are designed to allow the user to vary the proportions of the man-model to suit a particular situation or problem, and to position the man-model within the crew station to assess human performance and to aid in placement of controls and panels.

In order to display the man-model on the CRT, the COMBIMAN uses data from on-line disk files and from user supplied data on anthropometric surface dimensions. The ability to make use of user supplied anthropometric data permits the construction of man-models of variable proportions suitable to the particular needs of the user. To define the man-model, the program CBM05 (COMBIMAN program Version 5) requires values for the 12 anthropometric variables to generate the 35 internal link lengths. The user can either supply values for all 12 variables or supply values for one mass-related and one length-related variable and let the program compute the other ten variables using multiple regression equations. The user supplied data may be (a) direct measures obtained from specific subjects; or (b) percentile values chosen from COMBIMAN Anthropometric Data Base. The latter option is generally the most useful, as it limits the range of values for user supplied dimensions and eliminates unrealistic combinations of dimensions. The program CBM05 may end abnormally when unrealistic combinations of anthropometric dimensions are supplied.

The man-model can be positioned in a crew station by directly entering sets of rotational angles used to position the links of the model, or with the PERFORM REACH ANALYSIS function (see Paragraph 2.2.11) by specifying a point on the display. The later method applies to reach involving the arms and incorporates automatic restrictions to mobility. The user may also

initialize the man-model in the standard anthropometric seated measuring posture (ERECT POSTURE), the SLUMPED POSTURE, which is an erect posture positioned in a 13 degree seat back angle and six degree seat pan angle, or a third posture (PRGM'D POSTURE) interactively designed by the user.

Other information available to the user includes hard copy plots of the display, printed output showing the three dimensional real world coordinates of the man-model and of the panels of the crew station, and visibility plots, which give the user information on the visual field of the crew station based on the eye position of the man-model.

#### 1.4 THE COMBIMAN PROGRAMS

The COMBIMAN system is divided into five programs, the main program being the interactive graphics program CBM05, which allows the user to generate a variable size man-model and to assess its interaction with new or existing crew stations. Before the user can define the proportions of the man-model, or call up crew stations and visibility contours for evaluation, the files which store the anthropometric, crew station, and visibility member data must be created. This is done by using three specialized file creation/modification programs, each dealing with a particular type of data set: anthropometric, crew station, or visibility member. Similar sets of commands are used by each program to initialize the file, to add or delete data, to write existing data groups to the printer, or to punch data groups to cards. The data flow of the COMBIMAN program is shown in Figure 5. Figure 5 also shows a fourth file, the initialization data set, which contains data used to construct the man-model and cannot be modified by the user.

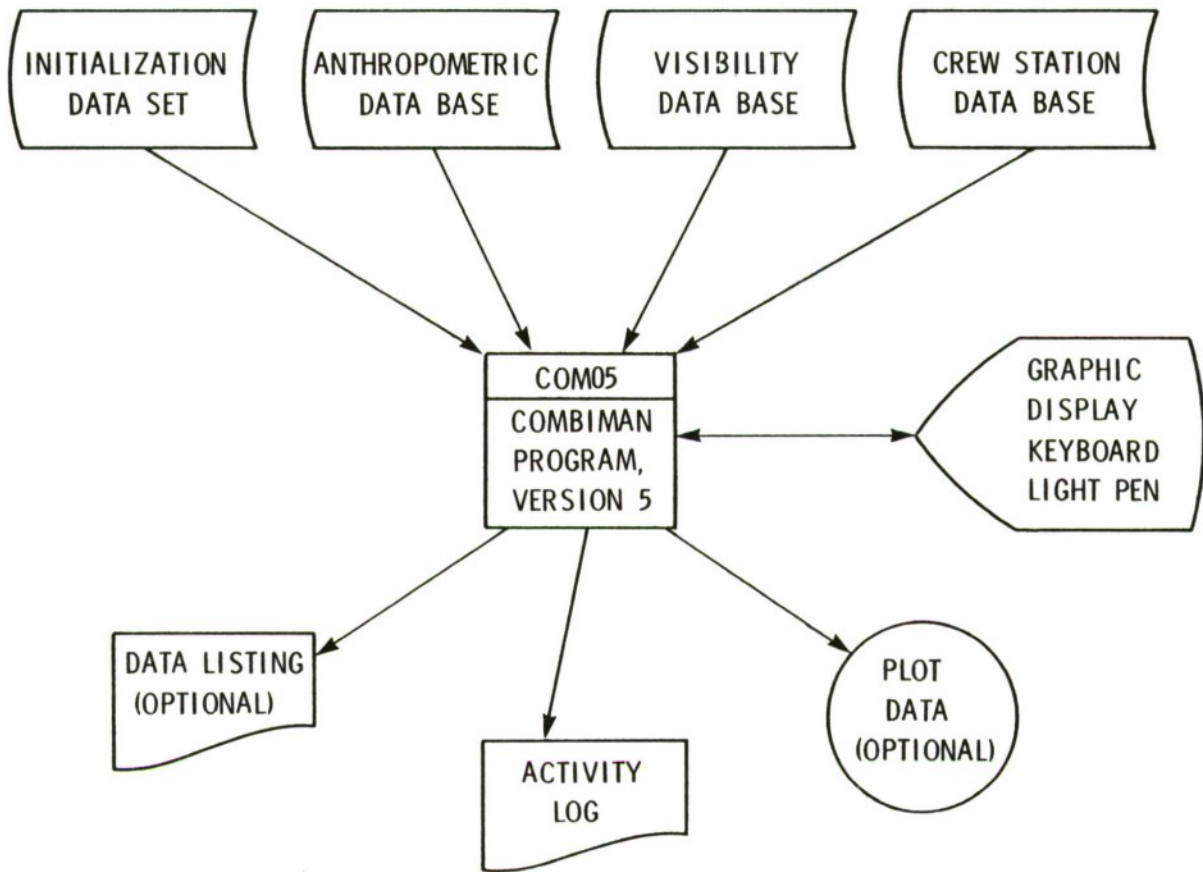

Figure 5. Data Flow in the COMBIMAN Program.

The following sections explain the operation of five key programs of the COMBIMAN system, including the interactive graphics program CBM05, the off-line plot program CBMOFF, and three of the file manipulation programs which maintain the data files used as input to CBM05. The manipulation of the man-model and crew station using CBM05 is straightforward. Sections 1 and 2 of this guide provides a designer not skilled in computer programming with sufficient information to use CBM05 interactively. Due to the technical nature of the data and operations described in Sections 3, 4, 5, and 6 some computer skill is required to interpret and use these programs.

Section 2 describes the use of the program function keys which may be activated by the user in program CBM05 to manipulate the man-model and to design and evaluate crew stations. This section includes examples of optional as well as standard output formats supplied by the program, and lists possible error or information messages generated by the program.

Section 3 describes the COMBIMAN off-line plotting program, CBMOFF. This program uses data generated by CBM05 to produce plots of variable size, color, and content from the three-dimensional coordinate data. Input formats, plotting options, and program output are explained in this section.

The program which creates and maintains the Data Base containing the Anthropometric surveys, CBMAM, is documented in Section 4. The types of stored data, the sources for such data, and the formats for data input, sample output, and action and error messages are discussed. The uses of, and formats for, the commands or functions which manipulate the file as well as the data are also described.

The program which creates and maintains the Data Base containing the geometric descriptions of crew station configurations, CBMCM, is documented in Section 5. The program which creates and maintains the Data Base of geometric descriptions of crew stations for visibility plots, CBMVM, is documented in Section 6. Data sources and formats for input, output, and messages are also described for both programs. In addition, these sections contain examples of Job Control cards to run these programs.

DEPRESS PFK 0

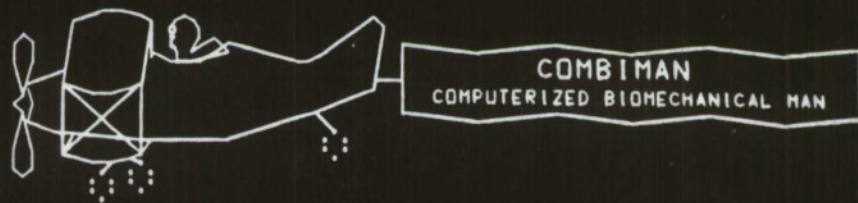

PROPERTY OF  
AFAMRL

DEVELOPED BY  
UDRI

BEGINNING OF COMBIMAN PROGRAM

SECTION 2  
THE COMBIMAN INTERACTIVE GRAPHICS PROGRAM  
VERSION 5 - CBM05

At the heart of the COMBIMAN system is the fifth version of the COMBIMAN interactive graphics program CBM05. The program uses an IBM 2250-3 Display Unit for designing and analyzing crew station configurations. The user at the display device controls the course of execution of program CBM05 using a Program Function Keyboard, a light pen, and an alphanumeric keyboard. Functions of the program are executed by depressing lighted Program Function Keys. This section describes the functions available to the COMBIMAN user, shows the output these functions generate, and traces through suggested execution sequences to generate the man-model, and to retrieve a crew station.

## 2.1 INTRODUCTION

The graphics program CBM05 enables the designer to bring together the information on anthropometry and crew stations stored on disk (see Sections 4 and 5) and to combine them with the interactive qualities of the Cathode Ray Tube. This enables one to evaluate real-life conditions, or to establish design criteria for new situations in a fraction of the time it would take using conventional methods.

For design and evaluation sequences, the 12-inch square CRT screen is partitioned into Prompting, Information, and Display areas (see Figure 6). The Prompting Area displays messages indicating what the user should do next. This area is also used to accept replies through alphanumeric keyboard when

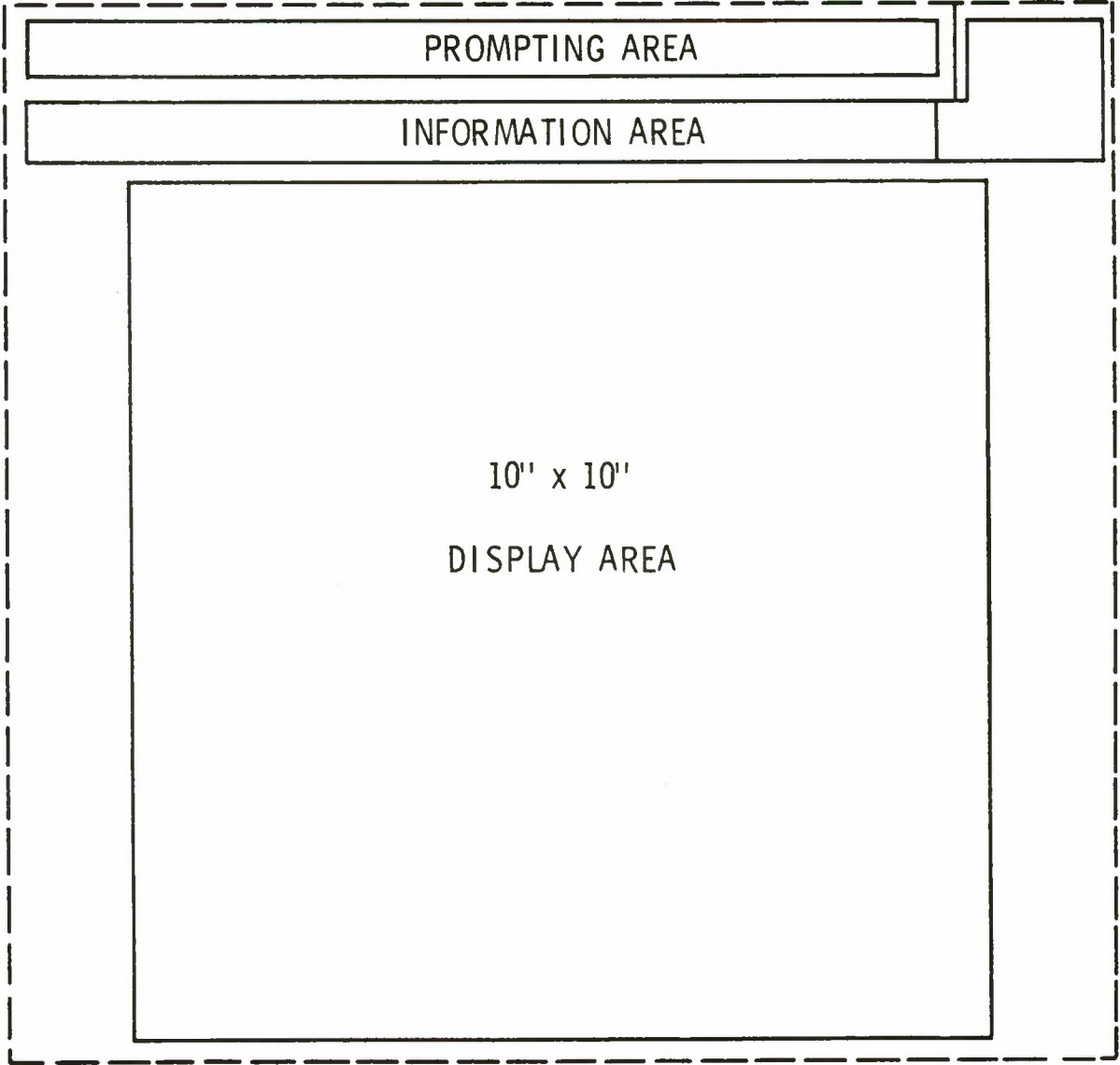

Figure 6. Format of IBM 2250-3 Display Unit. The program adjusts the size of the displayed image to fill the 10" x 10" display area. Selecting a front view may cause the man-model and crew station to appear larger, but the coordinate information remains unchanged.

requested. The Information Area displays the anthropometric survey name, the crew station name, flight suit and helmet types, seat type and offset, mobility, and posture information. The 10-inch square Display Area is used to display the man-model, crew station and roll, pitch and yaw angles, if different from zero. The three dimensional coordinates of the reach point during Reach Analysis, the coordinates of the current vertex during a panel design, and the visibility member names during Visibility Plot Functions are also displayed in the Display Area.

Replies to prompting messages are given through the Alphabetic Keyboard (ANKB), the Light Pen, or the Programmable Function Keys (PFK). Replies given through ANKB are displayed in the Prompting Area below prompting message and are processed by the program after simultaneously depressing the ALT CODING key and the "5" key.<sup>1</sup> A light pen reply is given by aiming the light pen beam at the desired response displayed on the CRT, and depressing the light pen barrel against the screen.

Figure 7 shows an IBM 2250-3 CRT in use. The user's left hand is on the Program Function Keyboard, and his right hand is using the light pen to identify a point on the screen. The Alphanumeric Keyboard is shown below the CRT.

---

<sup>1</sup>In subsequent use in the text the simultaneous depression of the "ALT-CODING" and "5" keys will be referred to as the ALT-CODE/5 sequence. IBM refers to this sequence as EOB (End of Block). (IBM System Reference Library, Program Numbers 360S-LM-537.)

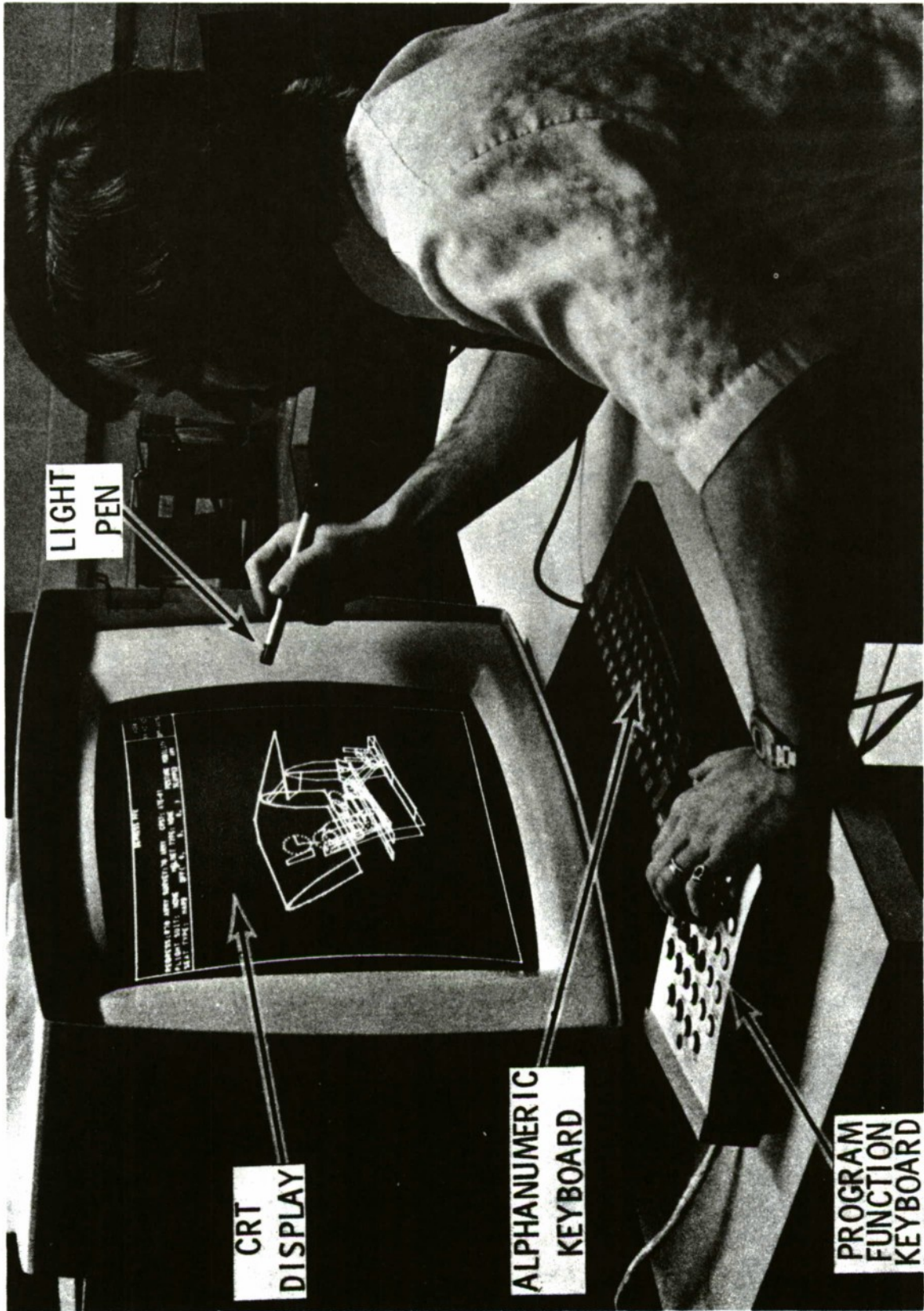

Figure 7. CRT Unit with Function Keys, Alphanumeric Keyboard and Light Pen.

### 2.1.1 Available Functions

The functions which are available to users fall into six basic categories, as shown in Figure 8. The first category, the Anthropometry Related functions, enables the user to retrieve data for a particular anthropometric survey from the Anthropometric Data Base, specify values for the surface dimensions of the man-model, and manipulate the geometry of the model to achieve the desired man-model configuration. The Crew Station-Related functions allow the user to retrieve existing three-dimensional crew station configurations from the Crew Station Data Base and then add to and modify the retrieved configuration. These functions allow users to start from the beginning of a design sequence and create a new crew station configuration. The Display-Related functions allow users to rotate and to magnify the contents of the display area. They also enable users to identify objects within the Display Area, or modify the contents by omitting or by including objects. The user can evaluate the interaction of man-model with crew station through the Man-Machine Interaction Related functions. These functions provide users with a reach analysis routine and change posture functions. The Printer/plotter Related functions supply users with hardcopy output of the configuration of either the man-model or the crew station. The program generates plot output as soon as a plot function is activated, but the printed output occurs only at the end of the run. The final category, the Program Execution Related functions, permits the user to restart the program, or to end it. It also enables the user to set State Switches which either suppress or activate additional processing or printing.

A standard feature of the program is a listing of all actions taken by the user. This listing is a sequence of messages printed at the termination of the program CBM05.

<u>ANTHROPOMETRY-RELATED</u>	<u>CREW STATION-RELATED</u>	<u>DISPLAY-RELATED</u>
Retrieve Anthropometry Enter Twelve Dimensions Enter Two Key Dimensions Display Link Table	Retrieve Crew Station Design Panel Delete Panel Adjust Seat	Change View Identify Object Omit Object Include Object Change Perspective Zoom
<u>MAN-MACHINE-INTERACTION RELATED</u>	<u>PRINTER/PLOTTER- RELATED</u>	<u>PROGRAM-EXECUTION RELATED</u>
Perform Reach Change Posture Reset Roll, Pitch, Yaw	Print Data Plot COMBIMAN Generate Visibility Plot Dump CRT on Plotter	Set State Switch Restart CBM05 End CBM05

Figure 8. Functions Available to COMBIMAN User.

### 2.1.2 Requirements

At the Wright-Patterson Air Force Base, AFAMRL HESS facility, the program CBM05 runs on an IBM 370/155 Operating System Computer using an IBM 2250-3 graphics display terminal with light pen, alphanumeric keyboard, and program function keyboard, and an on-line Gould 5000 potter. The program requires 550K bytes computer memory and a minimum of 20K bytes graphics buffer control area. The Initialization, Anthropometric, Crew Station and Visibility Data Bases reside on a disk drive in a direct access format. The space requirement for each data base depends on the number of members and their complexities. IBM System/360 Operating System Graphic Subroutine Package (GSP) for FORTRAN IV is used to create displays on the CRT. Gould 4800/5000 IBM System/360/370 Plot package is used for on-line plotting.

Other requirements for specific functions are described in the appropriate paragraphs which follow.

## 2.2 AVAILABLE PROCESSING

Functions of Program CBM05 are requested by means of the Program Function Keyboard. This keyboard consists of 32 keys, numbered 0 to 31, whose functions are assigned by program CBM05. When a function is enabled, the appropriate button on the PFK will be lighted. The primary functions for Program CBM05 are shown on the PFK Overlay Mask in Figure 9. The circles in Figure 9 represent the PFKs. Their numbers are shown above and to the left of each circle. The numbers within the circles represent the subsections where the functions are described. For example, PFK0 contains a "1" within the circle and is described in Paragraph 2.2.1. A function is requested by a single, momentary depression of the corresponding PFK.

COMBIMAN PROGRAM  
VERSION 5

MAY 81

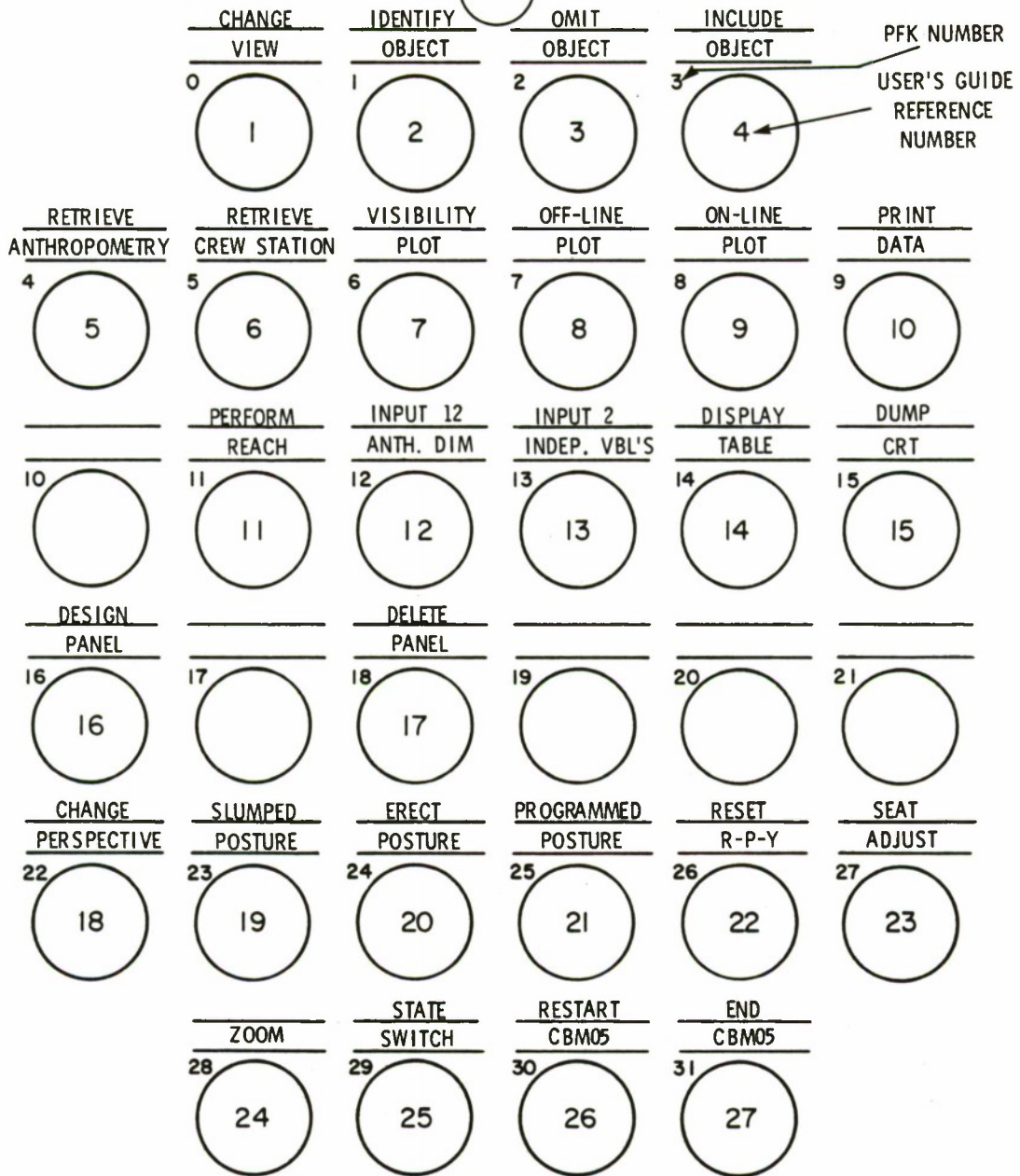

IBM

Figure 9. Program Function Keyboard (PFK) Overlay for Program CBM05.

Once the program is loaded (for instructions on loading, see Paragraph 2.3.1) the prompting area of the screen will display the message "DEPRESS PFK4 TO SELECT ANTH DATA". The first sequence of steps the user follows should utilize Anthropometry Related functions to generate the man-model. The mandatory sequence is shown in Figure 10. The number in each block refers to the paragraph which describes the function.

After the man-model is generated and displayed on the CRT, the user may choose to manipulate the man-model using the Display-Related functions, or may retrieve or develop a crew station using the Crew Station Related functions. (Should be selected before deleting panels.) The Program Execution Related functions (see Figure 8) are always enabled and may be depressed at any time during the execution of CBM05.

The following paragraphs describe the processing performed by each function as numbered in Figure 9.

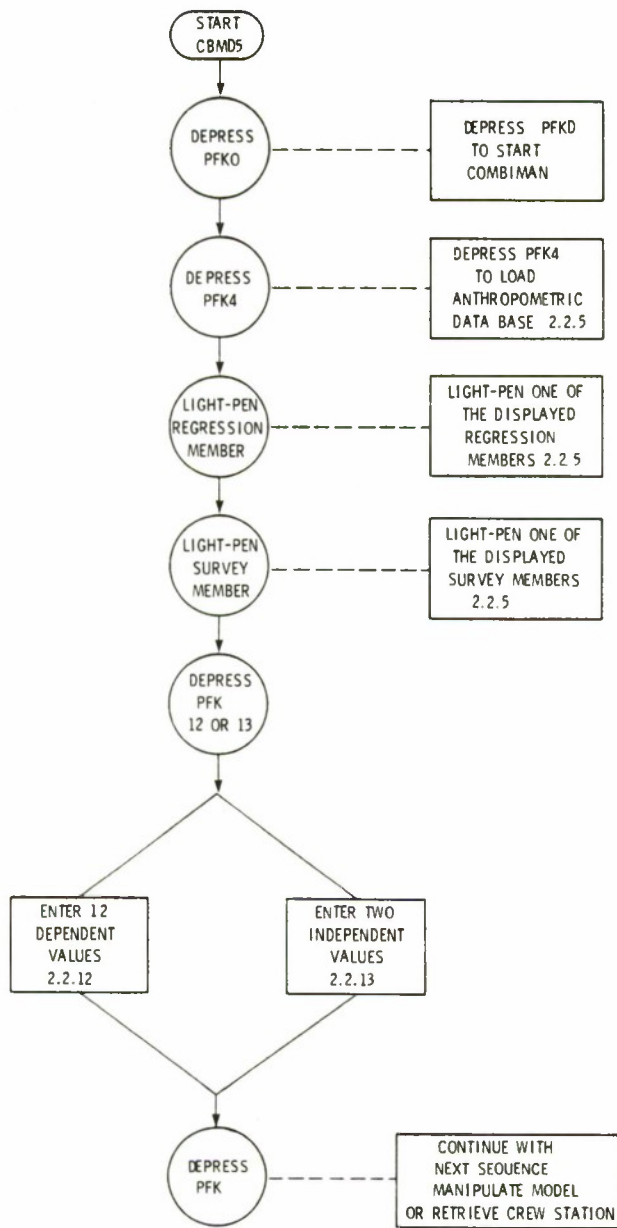

Figure 10. Function Sequence for Generating the Man-Model.

### 2.2.1 CHANGE VIEW Function (PFK0)

The CHANGE VIEW function allows users to rotate the man-model and the crew station in the display area of the screen as shown in Figure 6.

Once this function key is selected, the program prompts the user to select either a new view-plane for the display area, or to define a new off-axis orientation of the man-model and crew station. To change the view-plane, the user responds to the message "L.P. VIEW CHANGE" by light penning "XY" for a top view, "XZ" for a side view, or "YZ" for a front view of the man-model and crew station. Then the program regenerates the display in the new view-plane. Figures 11, 12, and 13 show the display of COMBIMAN in the A7E-01 cockpit in the XY (top), XZ (side), and YZ (front) view-planes respectively.

If the user responds to the message "L.P. VIEW CHANGE" by light penning "OFF-AXIS" in the upper-right corner of the screen, the program prompts users to enter the new roll, pitch, and yaw angles. Angles are specified from the ANKB in degrees by typing the value and following the ALT-CODE/5 sequence. The default value, 0 degree for these angles, is entered by simply depressing the ALT-CODE/5 sequence. The following sequence of replies rotates the man-model and crew station of Figure 12 to ROLL = 10 degree, PITCH = 0 degree, and yaw = -15 degree.

10	(Change ROLL to 10 degree)
ALT-CODE/5	(Enter ROLL = +10 degree)
ALT-CODE/5	(Enter PITCH = 0 degree)
-15	(Change YAW to -15 degree)
ALT-CODE/5	(Enter YAW = -15 degree)

Once the ALT-CODE/5 sequence for the YAW angle is entered, the display will be rotated.

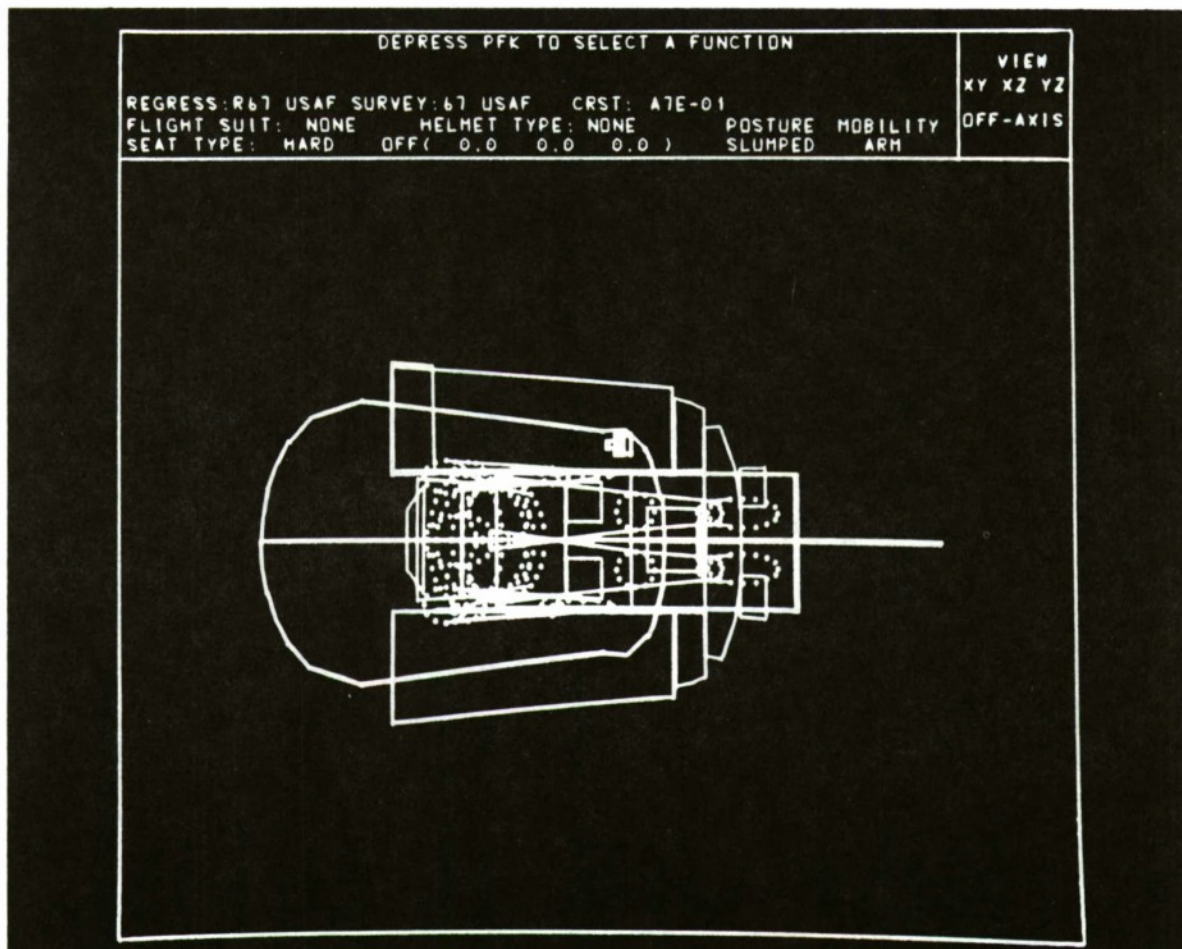

Figure 11. Top View (X-Y Plane) of the Man-Model and a Crew Station.

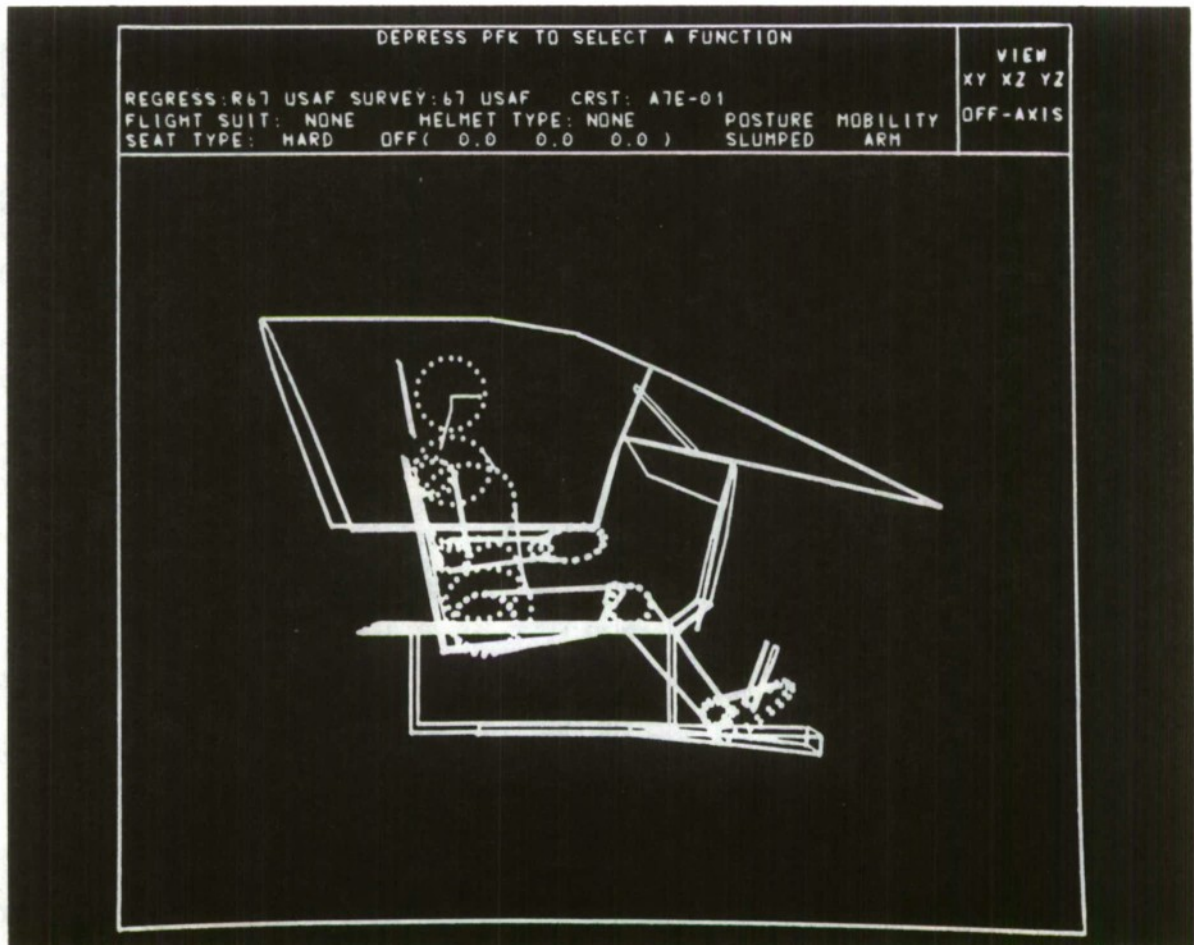

Figure 12. Side View (X-Z Plane) of the Man-Model and a Crew Station.

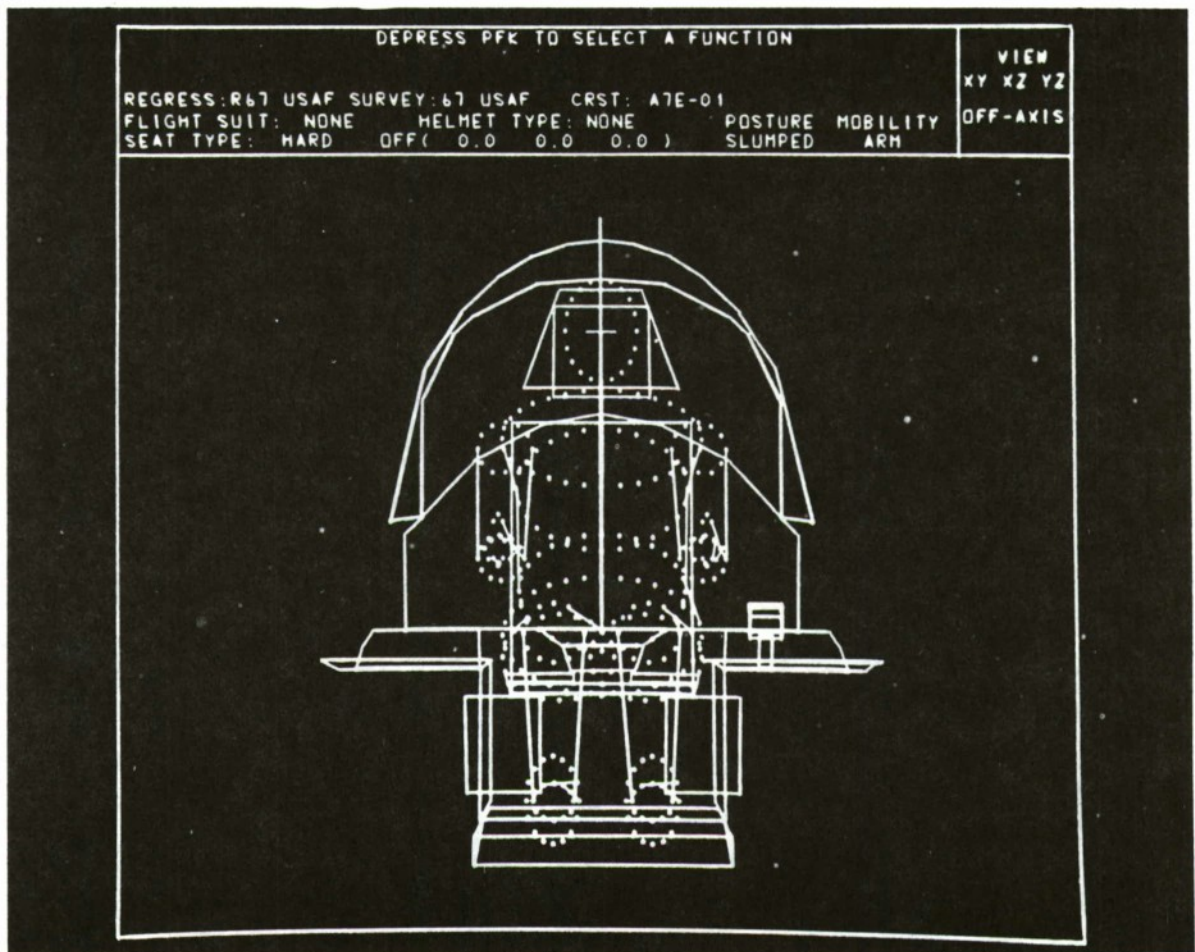

Figure 13. Front View (Y-Z Plane) of the Man-Model and a Crew Station.

### 2.2.2 IDENTIFY OBJECT Function (PFK1)

The IDENTIFY OBJECT function displays identifying information in the Information Area of the CRT for any object (man-model skeletal link or crew station panel) chosen by the user. After depressing PFK1, the message "LIGHT-PEN OBJECT" appears in the Prompting Area of the CRT. The user must then light-pen the object to be identified.

The following three pieces of information for the light-penned object are displayed in the Information Area:

- 1) The internal reference number of the object,
- 2) Reference coordinates for that object, and
- 3) The 8-character name of the object.

The internal reference number is a unique integer, assigned by the program, which identifies each link or panel. The reference coordinates for the object are the X, Y, and Z coordinates of the distal end point for man-model link or the X, Y, and Z coordinates of the first vertex (as defined in Crew Station Data Base - see Section 5) for selected panel. The 8-character name of the object is either the link name (see Table 3) or the name of the panel as it exists in the Crew Station Data Base. Figure 14 shows the result of an IDENTIFY OBJECT function performed on the HUD (heads up display) in the A7E-01 crew station. The information displayed in the Information Area of the CRT,

```
62    22.09    3.74    32.26    HUDSCRN
```

indicates that its internal reference number is 62, the coordinates of its first vertex are X = 22.09, Y = 3.74, and Z = 32.26, and its name is HUDSCRN.

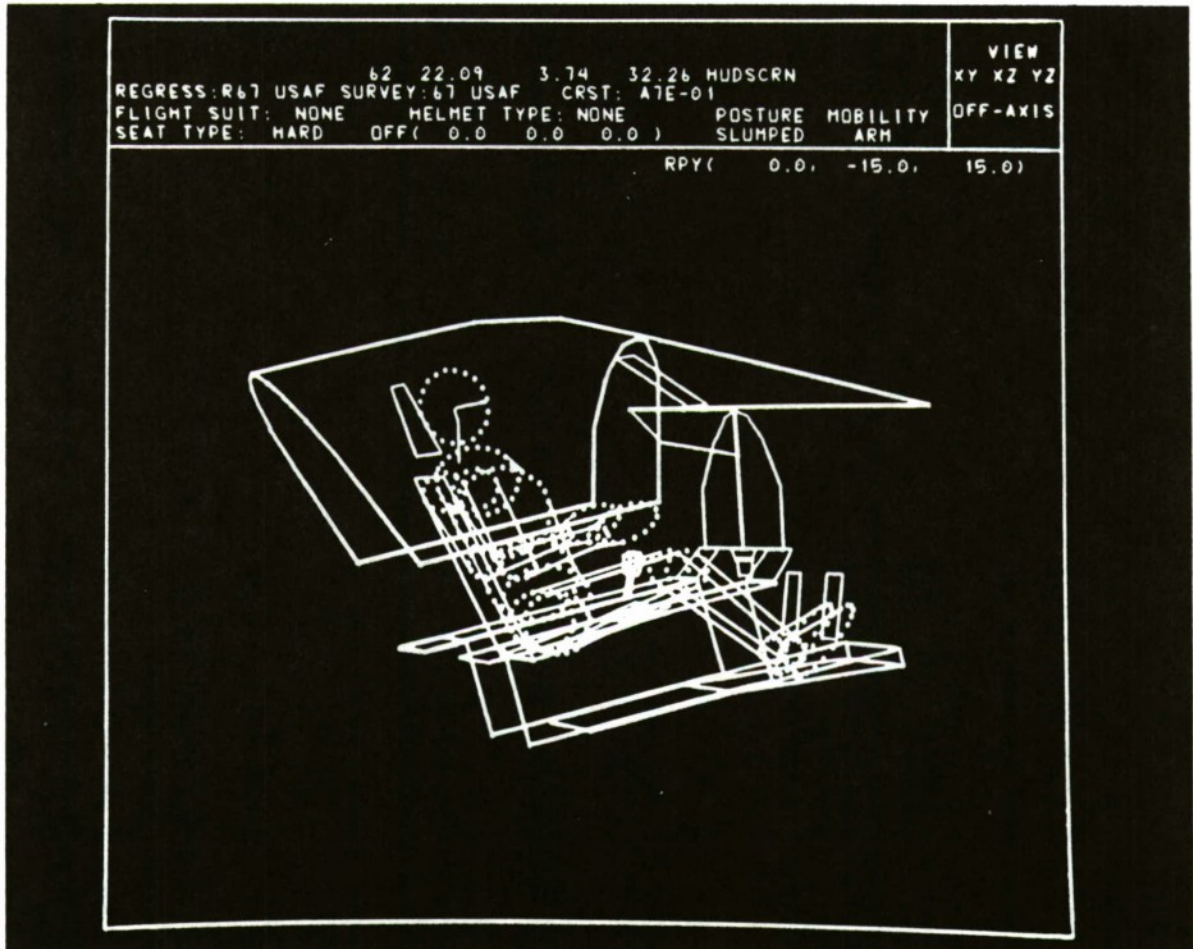

Figure 14. The IDENTIFY OBJECT Function Performed on the HUDSCRN (Heads Up Display) of the A7E-01 Crew Station.

The message "CBM010I IDENTIFIED link/panel name" along with distal end coordinates of the identified link or coordinates of all vertices of the identified panel are printed on the message unit.

### 2.2.3 OMIT OBJECT Function (PFK2)

The OMIT OBJECT function temporarily removes a crew station panel or a man-model segment from the display. This function is used to "de-clutter" the display.

On depressing PFK2, the message "LIGHT-PEN OBJECT" appears in the Prompting Area of the CRT. The user must then light-pen the object to be omitted. The program then displays the internal reference number of the object, the X, Y, and Z coordinates of the distal-end point of the selected man-model link or the X, Y, and Z coordinates of the first vertex of the selected panel, and the 8-character name of the object in the Information Area of the CRT. The internal reference number of the object is a unique integer, assigned by the program, which identifies each link and panel. It is the same number that the IDENTIFY OBJECT function displays and must be supplied by the user if the INCLUDE OBJECT function (see Paragraph 2.2.4) is used to redisplay the omitted object. The user may write down these numbers for future reference. Any omitted object can be redisplayed by supplying its internal reference number while performing INCLUDE OBJECT function. Also, all omitted objects are redisplayed whenever the man-model and crew station are regenerated (e.g. during a CHANGE VIEW function or a function which involves use of the cross symbol). Figure 15 shows the message created by OMIT OBJECT function when heads up display screen (HUDSCRN) of A7E-01 crew station is light-penned and Figure 16 shows the display with the HUDSCRN omitted. Note that the message generated by OMIT OBJECT function on CRT display is identical to that of IDENTIFY OBJECT function.

The message "CBM011I OMITTED link/panel name" and distal end coordinates of the omitted link or coordinates of all vertices of the omitted panel are printed on the message unit.

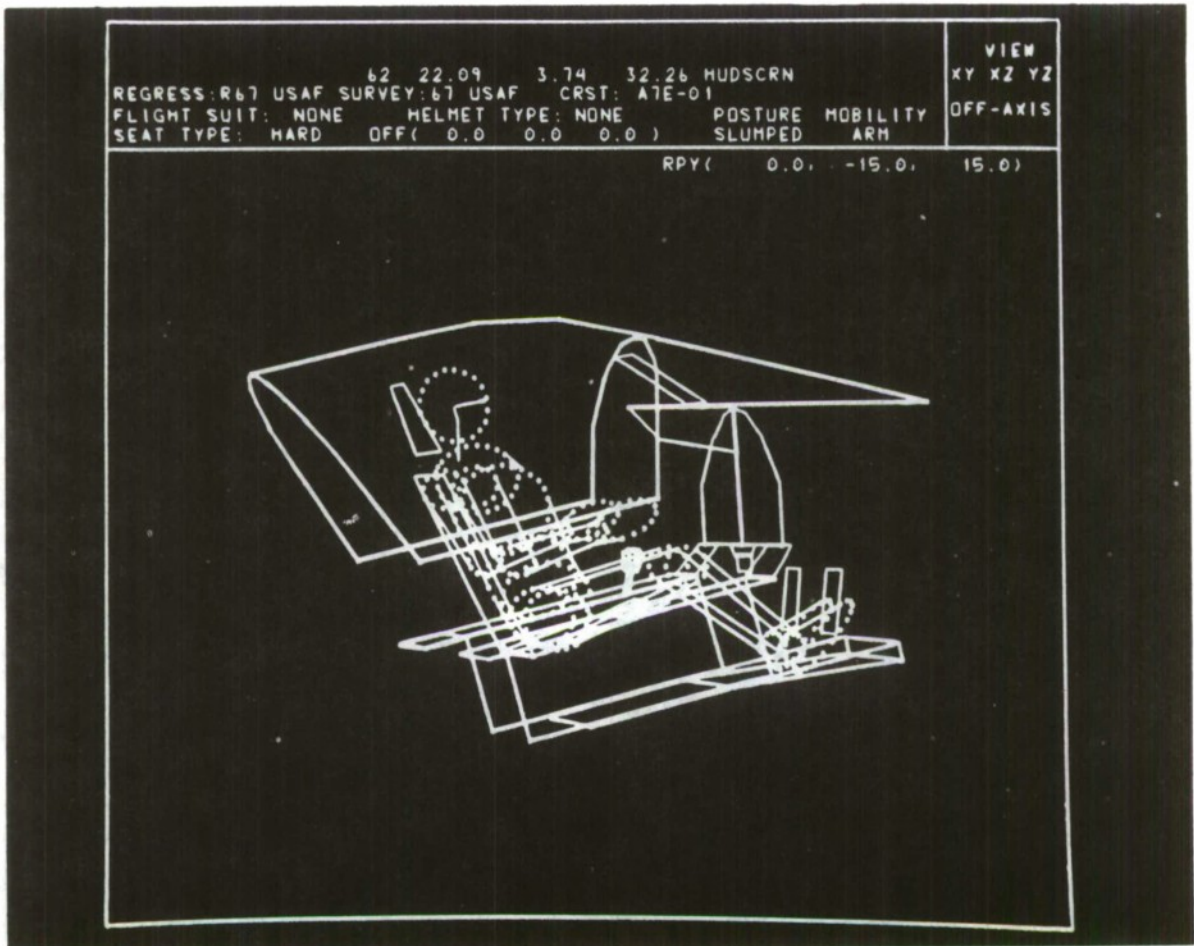

Figure 15. The OMIT OBJECT Function Performed on the HUDSCRN (Heads Up Display) of the A7E-01 Crew Station (Name of Light Penned Object is Displayed).

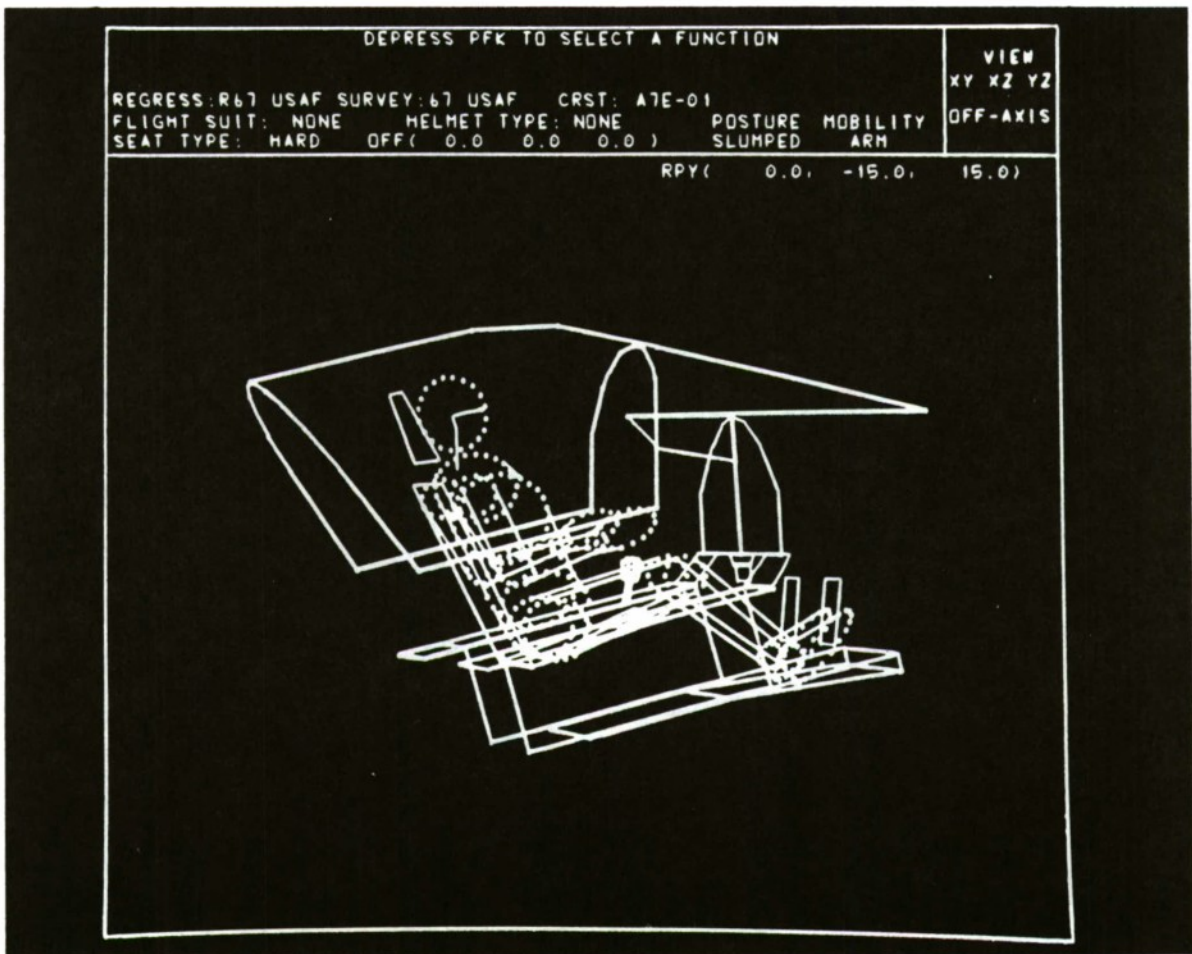

Figure 16. The OMIT OBJECT Function Performed on the HUDSCRN (Heads Up Display) of the A7E-01 Crew Station.

#### 2.2.4 INCLUDE OBJECT Function (PFK3)

The INCLUDE OBJECT function redisplay an object that was removed from display screen by OMIT OBJECT function. After depressing PFK3, the message "ENTER OBJECT NUMBER" appears in the Prompting Area of the CRT. The number is entered through ANKB followed by ALT-CODE/5 sequence. The only valid entries for this function are internal reference numbers of man-model skeletal links or crew station panels which have previously been deleted by OMIT OBJECT function. The program will keep prompting for a valid internal key number until the user supplies one or enters the ALT-CODE/5 sequence to ignore the function and return to the main program. There are no other messages associated with this function. Depressing PFK3 and entering key number 62 (HUDSCRN reference number) for the INCLUDE OBJECT function with Figure 16 would cause the heads up display screen to reappear in its original position in the crew station. The man-model and crew station display will once again look like that of Figure 15.

#### 2.2.5 RETRIEVE ANTHROPOMETRY Function (PFK4)

This function is the first step in defining the size of the man-model. The user is first prompted to light-pen the name of a "regression member" from the Anthropometric Data Base. (A detailed explanation of regression and survey members is given in Section 4.) Regression membernames are displayed in the column headed "REGRESSION MEMBER", as shown in Figure 17. To choose the 1967 Survey of the USAF Flying Personnel, the user must light-pen R67 USAF; and to choose the 1970 Survey of U.S. Army Aviators the user must light-pen R70 ARMY\*. Once a membername is light-penned, the message "MEMBER membername ACCEPTED" is displayed in the information area of the screen.

After the regression data are retrieved from the Data Base, the user must light-pen a Survey member name displayed on the CRT which corresponds to the selected regression displayed in the column headed "SURVEY MEMBER", as shown in Figure 18. (For each regression member only one survey member is supplied in this version.) While the message "MEMBER membername ACCEPTED" is displayed in the Information Area, the means, standard deviations, and percentiles for the anthropometric dimensions are retrieved from the Data Base.

The message "DEPRESS PFK 12 OR 13" then appears in the Prompting Area of the CRT. Here the user selects the anthropometric surface dimensions or internal link lengths vital to the generation of the man-model. The sequence of steps associated with these function keys is described in Paragraphs 2.2.12 and 2.2.13.

---

\*NOTE: Other sets of survey data will be available in future updates of COMBIMAN or the user may create new members using the COMBIMAN Anthropometric Data Base Maintenance program (CBMAM).

L.P. REGRESSION MEMBER

REGRESSION MEMBER

R67 USAF

R68 AFM

R68 AFMF

R70 ARMY

R64 NAVY

Figure 17. Table of Available Regression Member Names - One Member Must Be Selected by Light Penning.

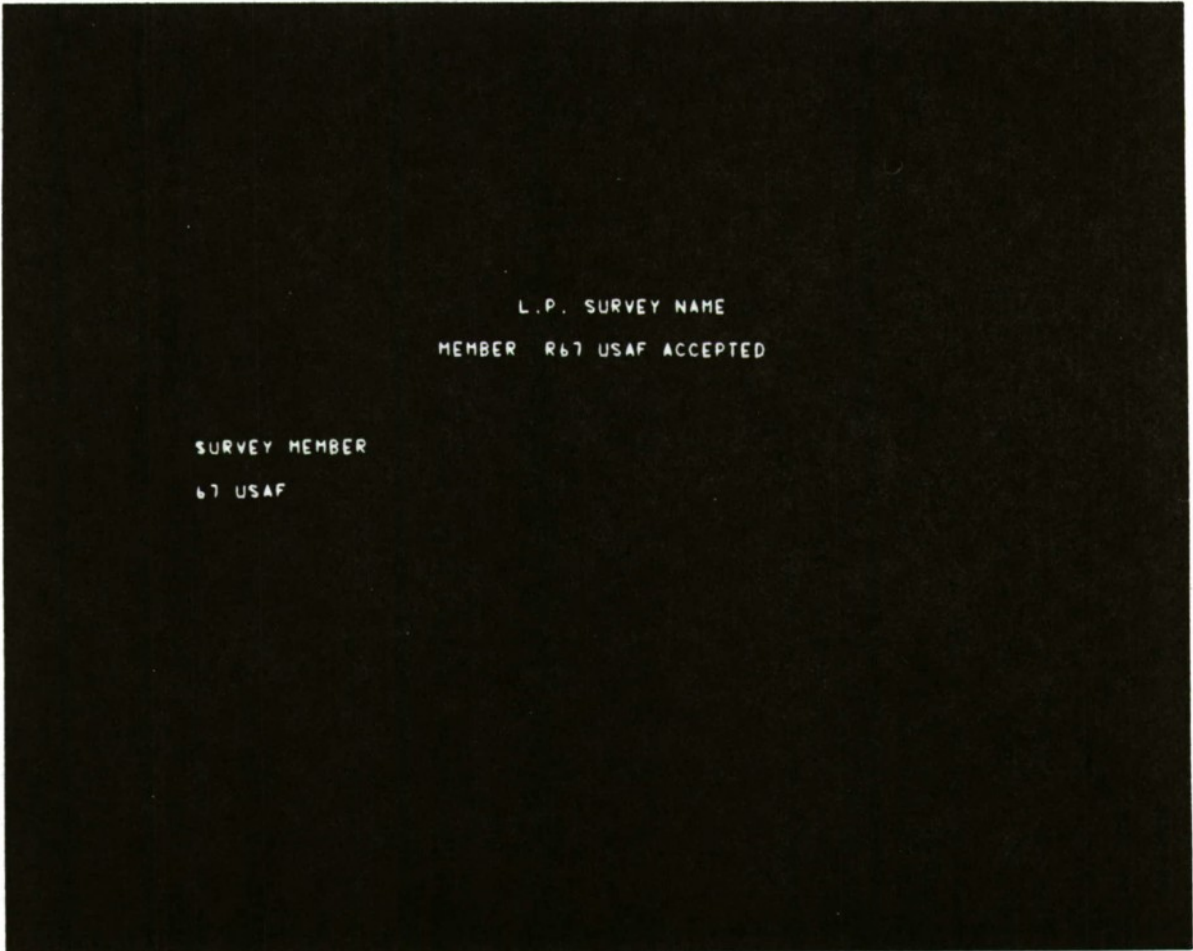

Figure 18. Table of Survey Member Name (for Regression Member R67 USAF) One Member Must Be Selected by Light Penning.

While the computations using the anthropometric data are in progress, the message "HUMAN ASSEMBLY" is displayed in the Information Area of the CRT. After this, the information is assembled for display and the message "CREATING DISPLAY" is displayed in the Information Area and the new man-model (and crew station if one was previously cued) appears on the screen.

### 2.2.6 RETRIEVE CREW STATION Function (PFK5)

The RETRIEVE CREW STATION function allows the user to retrieve a crew station from the Crew Station Data Base. After PFK5 is depressed, the user is prompted to light-pen a crew station. The crew station membernames are shown in Figure 19. The crew stations without seats are listed in the first column, and the seats are listed in the second column. The third column contains "\*ERASE\*" and "\*NONE\*". If a crew station name is light-penned without erasing the previous crew station, both crew stations are superimposed in the display. If "\*NONE\*" is light-penned, the RETRIEVE CREW STATION function is cancelled.

In order to erase all existing crew stations from the display area, depress PFK5 and light-pen "\*ERASE\*" and "\*NONE\*" in that order. When intentionally superimposing two or more crew stations, if the total number of panels exceeds 250, an overflow condition exists, and the message "TOO MANY PANELS/VERTICES \* RETRY" appears in the Prompting Area of the CRT. The program then redisplay the crew station membernames as shown in Figure 20. The user may light-pen "\*NONE\*" to cancel the last entry and relieve the overflow condition.

L.P. CREW STATION

CREW STATION MEMBER

YAH64CPG	A7--SEAT	*ERASE*
PAVLD	A10-SEAT	
C130/P&C	B1--SEAT	*NONE*
C130/NAV	SAC-SEAT	
F-16A	YAH-SEAT	
A7E-01		
UM/IN		
B1-NAV01		
CH-53		
DESK		
SACL(40)		
A-10A		
YAH64PG		

Figure 19. Table of Available Crew Station Membernames. Only A7E-01 is included in the Crew Station Data Base released with the COMBIMAN system. The user must add other crew stations.

L.P. CREW STATION  
TOO MANY PANELS/ VERTICES #RETRY

CREW STATION MEMBER

YAM64CPG	A7--SEAT	#ERASE#
PAVLD	A10--SEAT	
C130/P&C	B1--SEAT	#NONE#
C130/NAV	SAC--SEAT	
F-16A	YAH--SEAT	
A7E-01		
UH/1N		
B1-NAV01		
CH-53		
DESK		
SACL(40)		
A-10A		
YAM64PG		

Figure 20. Table of Available Crew Station Member Name Displayed When the Total Number of Panels Exceeds 250.

### 2.2.7 VISIBILITY PLOT Function (PFK6)

The VISIBILITY PLOT function plots a map of visual azimuth and elevation line-of-sight angles to crew station components in the Visibility Data Base, as defined in MIL-STD-850, Rectilinear Plot. However, the plot of visual angles reflects the current orientation of the man-model within the crew station and the way the crew members would see the crew station from their viewpoint. After depressing PFK6 the message "ENTER EYE LOCATION (LINK NUMBER)" appears in the Prompting Area of the CRT. The user must select, as illustrated in Figure 21, the reference eye point to be used for the plot by entering "8" for Mid-Eye, "9" for Right Eye, or "10" for Left Eye using the ANKB and following the ALT-CODE/5 sequence. Now the available visibility members are displayed in a column under the heading "VISIBILITY MEMBER" as shown in Figure 22. The user then light pens the desired visibility member and the message "PLOTTING" is displayed in the Information Area of the CRT and the plot is generated on the GOULD plotter. The routine which performs this plotting uses the coordinates which define the vector from the mid-head position to mid-eye position (link 8) to calculate the angular orientation of the head from the horizontal and vertical directions. If the man-model is facing forward and looking straight ahead, the orientation of his head would be 0 degree from horizontal and 0 degree from vertical.

Figure 23 shows a sample visibility plot of a canopy clearline for a single seat aircraft. For this example, we chose the man-model to be 50th percentile weight and sitting height from the 1967 USAF Survey, seated erect, and looking straight ahead.

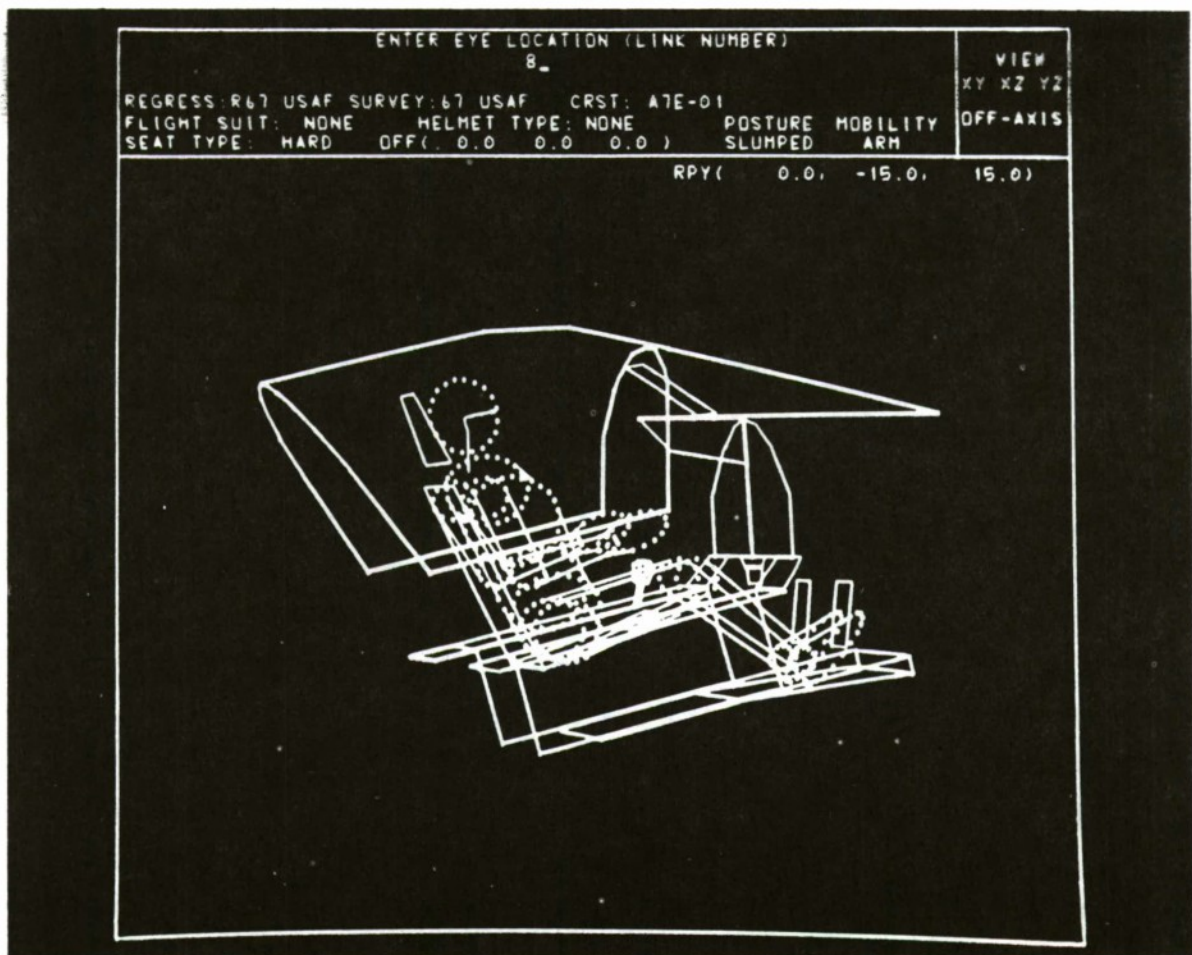

Figure 21. VISIBILITY PLOT Function. Enter Eye Location Link Number.

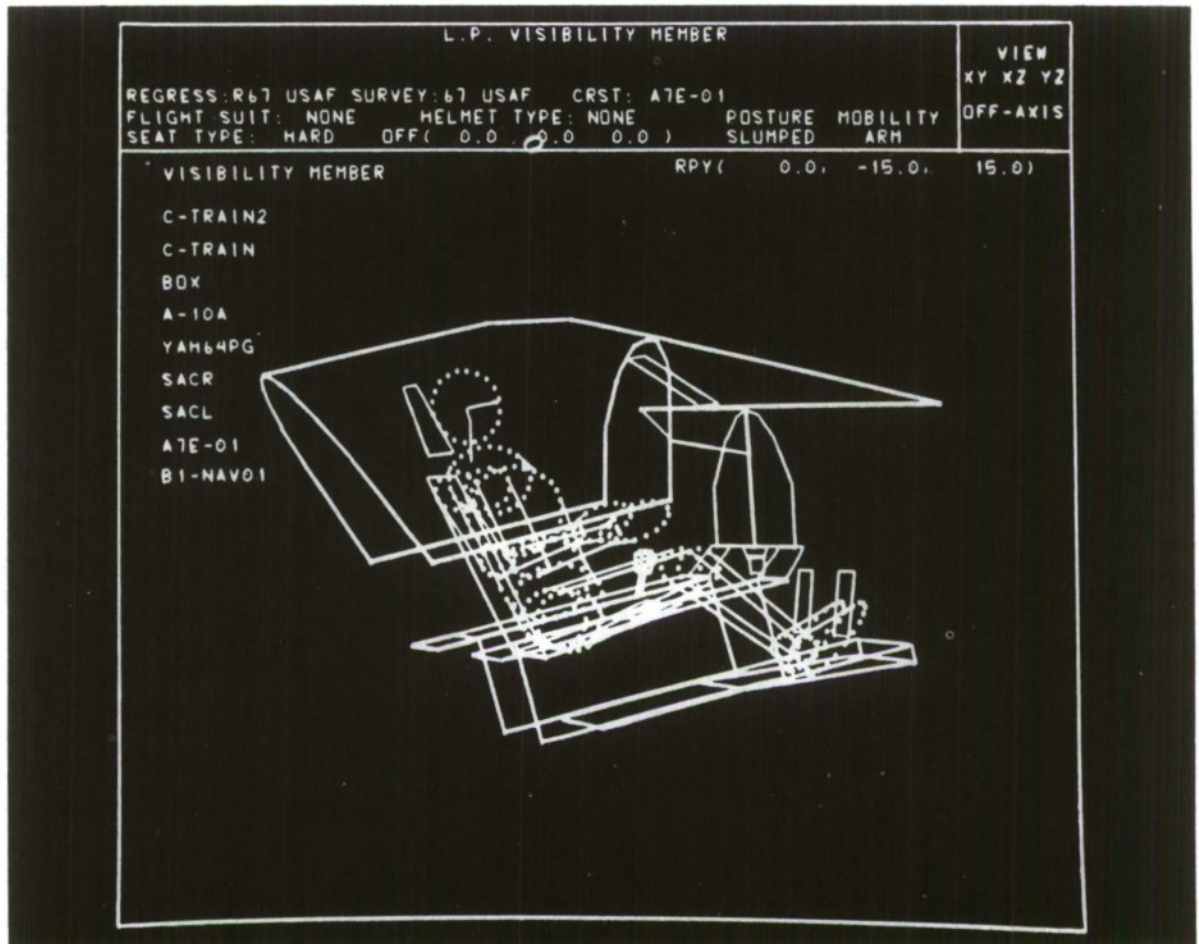

Figure 22. VISIBILITY PLOT Function. Select Visibility Member.

CREWMEMBERS HEAD IS POINTING 0° FROM FORWARD AND 0° FROM HORIZONTAL

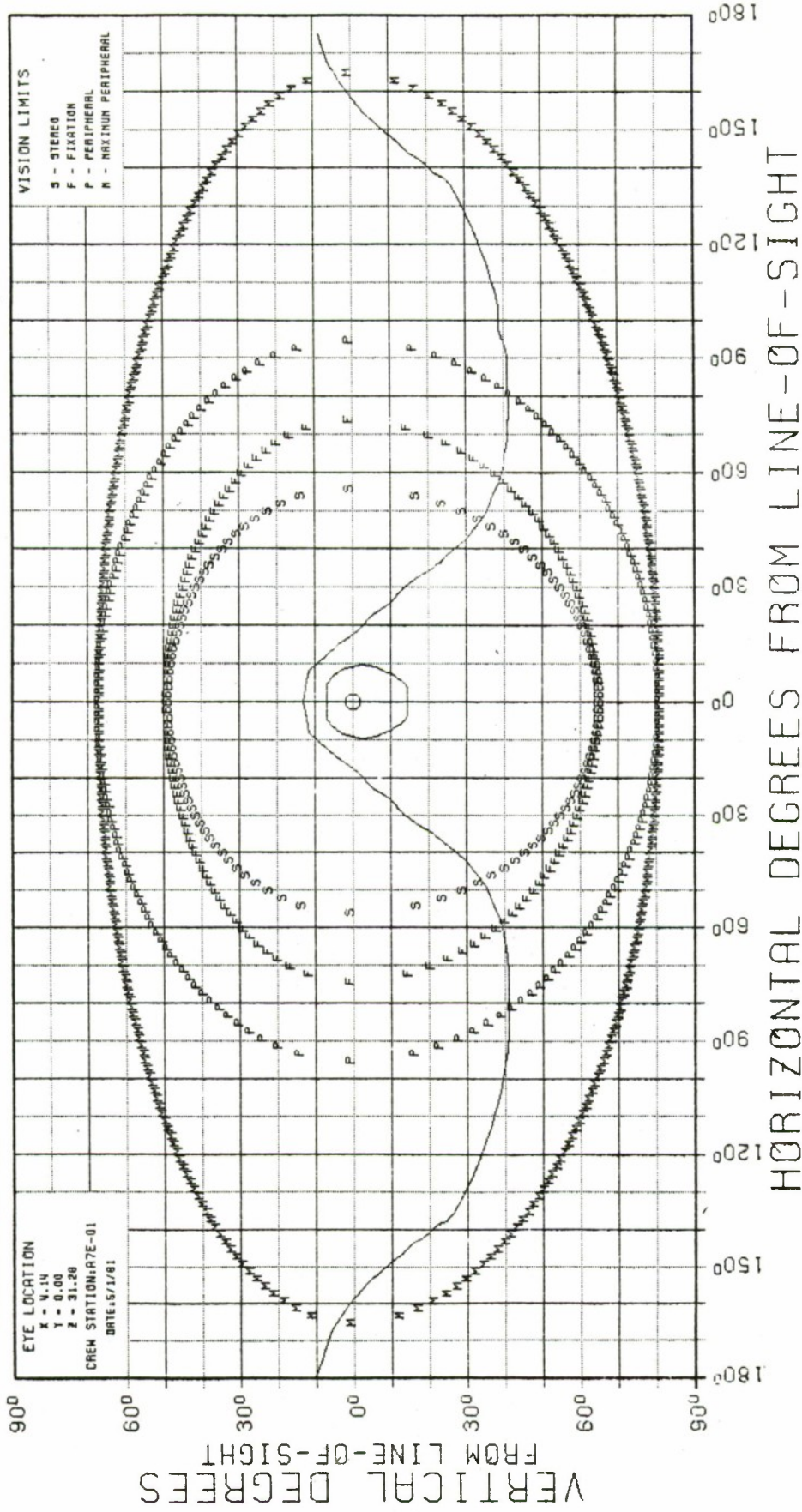

Figure 23. Visibility Plot.

The four ellipses superimposed on the plot define the limits of various visual fields. The innermost field, defined with letter S, is the field of stereovision, which is the field visible to both eyes simultaneously. The field defined with letter F, is the field of fixation, the region the eyes can see directly without turning the head. The field defined with letter P, is the field of peripheral vision with the eyes caged with respect to the head. The outermost field, defined with letter M, is the maximum peripheral vision limits for extreme eye deviations. The symbol "O" is the aim point of the head (and eyes if the eyes are caged forward with respect to the head). The vision limits are generated with respect to the angle of sight from the Mid-Eye point (end point of link 8).

In addition to generating a hard copy plot, if state switch 20 is set "ON" (see Table 4) the routine also calculates and prints a listing of the three dimensional coordinate of the objects plotted in five degree azimuth increments from -180 degrees from horizontal line of sight to +180 degrees for each panel and/or contour in the visibility member. This listing is a handy reference to the crew station drawings. The coordinates are given in the original user-supplied system of coordinates rather than the Neutral Seat Reference Point (NSRP) system of coordinates used elsewhere (see Paragraph 5.3.2.1). The listing also gives the coordinates of the eye location of the man-model. Figure 24 shows a part of the coordinate data for the plot in Figure 23.

VISIBILITY MEMBER NAME: A7E-01

EYE LOCATION IN SRP SYSTEM ( 4.14, 0.0 , 31.28)

LINE-OF-SIGHT IN DEGREES ( 0, 0)

VISIBILITY PLOT DATA FOR CONTOUR: WINDSCREEN, FRONT TOP

LINE-OF-SIGHT ANGLES		ORIGINAL COORDINATES		
HORIZ.	VERT.	A	R	U
5	-7	227.630	-5.840	125.350
7	-9	223.790	-5.510	123.240
7	-11	220.980	-5.460	121.570
6	-12	218.930	-5.190	120.590
5	-13	215.790	-4.870	118.760
5	-14	213.140	-4.270	117.350
4	-14	211.090	-3.620	116.160
3	-14	209.140	-2.810	115.840
0	-14	209.140	0.0	115.840
-3	-14	209.140	2.810	115.840
-4	-14	211.090	3.620	116.160
-5	-14	213.140	4.270	117.350
-5	-13	215.790	4.870	118.760
-6	-12	218.930	5.190	120.590
-7	-11	220.980	5.460	121.570
-7	-9	223.790	5.510	123.240
-9	-7	227.630	5.840	125.350
-9	-6	230.000	5.780	126.650
-9	-4	232.120	5.680	127.840
-10	-2	234.440	5.410	129.030
-9	0	237.310	4.700	130.590
-9	3	239.410	4.050	131.730
-7	5	241.090	2.920	132.860
-5	7	242.120	2.000	133.410
0	7	242.120	0.0	133.410
5	7	242.120	-2.000	133.410
7	5	241.090	-2.920	132.860
9	3	239.410	-4.050	131.730
9	0	237.310	-4.700	130.590
10	-2	234.440	-5.410	129.010
9	-4	232.120	-5.680	127.840
9	-6	230.000	-5.780	126.650

Figure 24. Canopy Outline Coordinates in Aircraft System.

## 2.2.8 OFF-LINE PLOT COMBIMAN Function (PFK7)

The OFF-LINE PLOT COMBIMAN function saves the coordinate data of the man-model and crew station currently displayed for later use to generate an off-line plot. The prompting and informational messages for this function and the necessary replies are identical to those for the ON-LINE PLOT COMBIMAN function described in Paragraph 2.2.9.

After depressing the OFF-LINE PLOT function key (PFK7) the message "PERSPECTIVE PLOT? ENTER Y/N" is displayed in the Prompting Area shown in see Figure 25. Here the user has the option to select a perspective or nonperspective plot. A perspective plot shows the man-model and crew station with infinite perspective (as displayed on the CRT). Nonperspective plot does not show any perspective. The user must type "Y" or "YES" for a perspective plot, or "N" or "NO" for a nonperspective plot using the ANKB, and must perform the ALT-CODE/5 sequence.

The program then displays the message "ENTER PLOT SCALE FACTOR" in the Prompting Area of the CRT. For a perspective plot, a scale factor of 1.0 produces a 10 x 10 inch plot identical to the size of the Display Area on the CRT. For a nonperspective plot, the scale factor is applied to full-scale data. The user must consider the size restrictions of the available plotter when specifying the scale factor. For example, a 1.0 scale perspective plot is about the same size as a 0.10 scale nonperspective plot.

To enter the scale factor, the decimal value is typed using the ANKB as shown in Figure 26 and is followed by the ALT-CODE/5 sequence. When a valid scale factor (greater than 0.0) is entered, the message "PLOTTING" appears in the

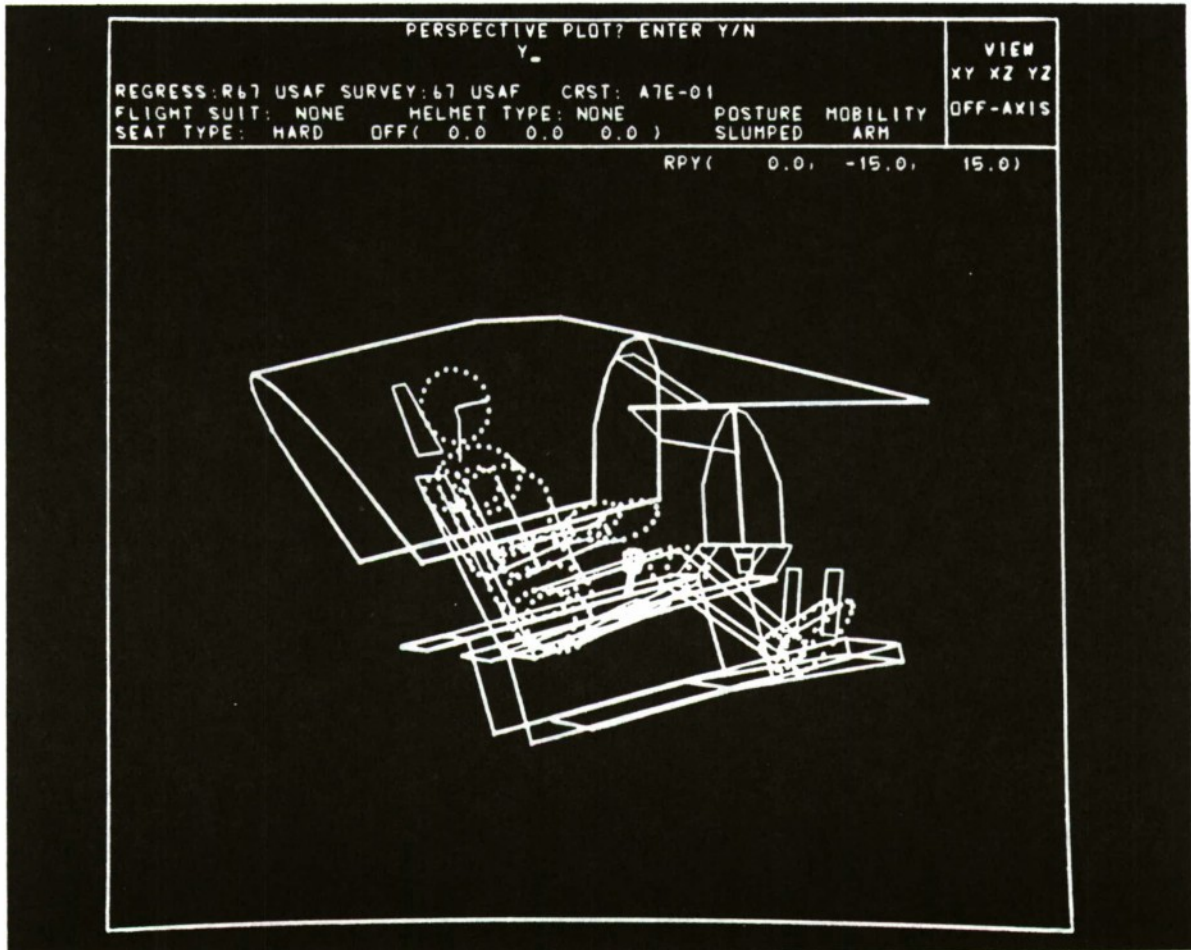

Figure 25. The Message and a Response for the COMBIMAN PLOT Function.

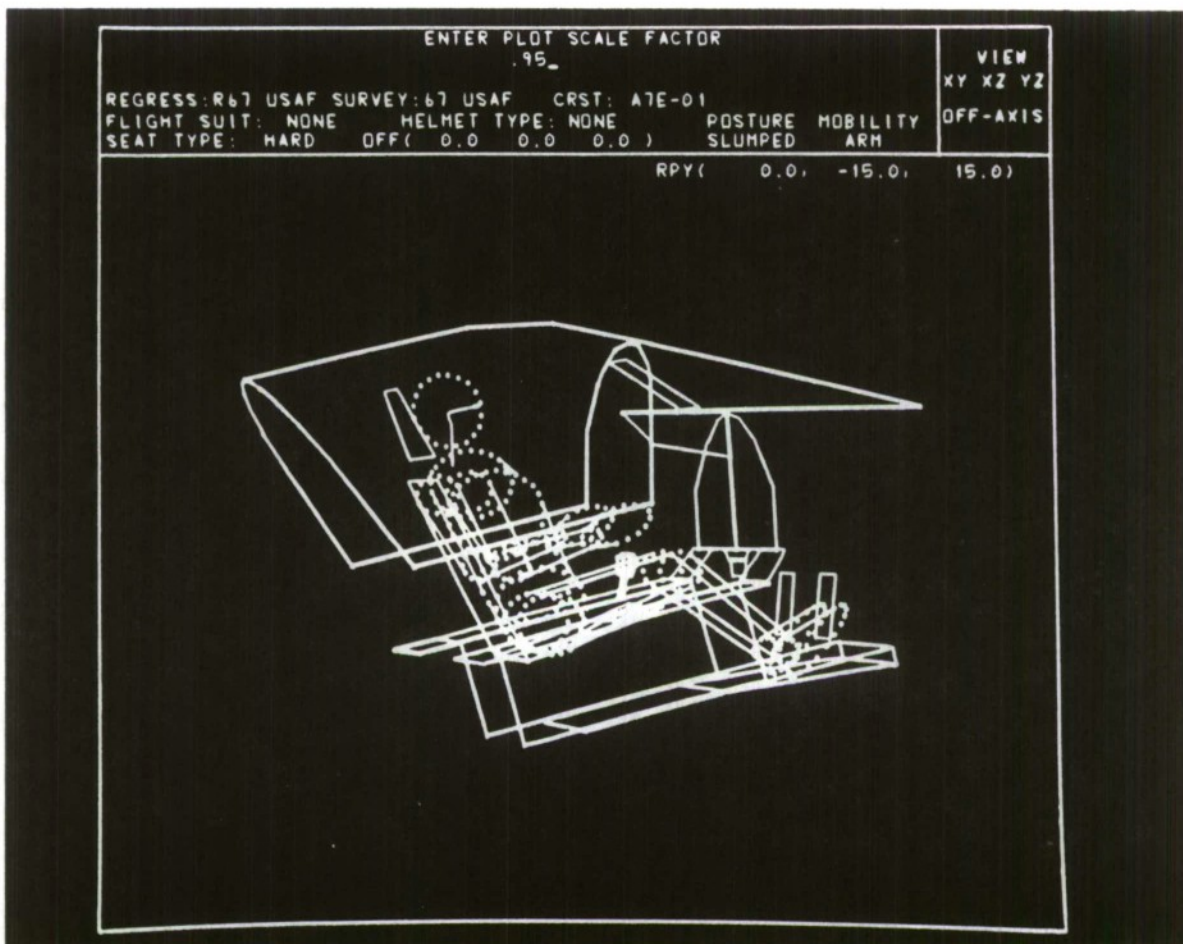

Figure 26. ON-LINE PLOT Function, Enter Plot Scale Factor.

Information Area of the CRT as shown in Figure 27 and the data are written to a disk file for later use as described in Section 3.

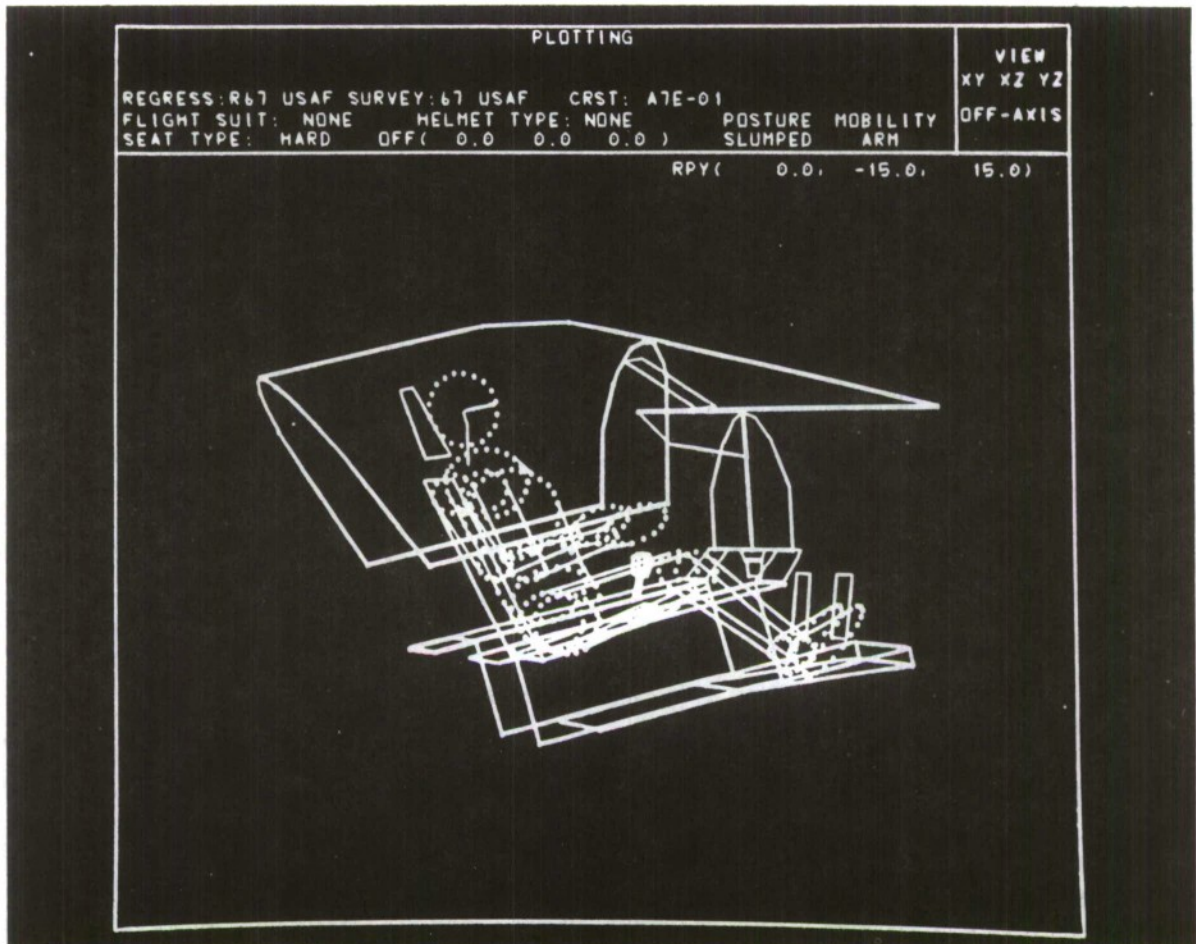
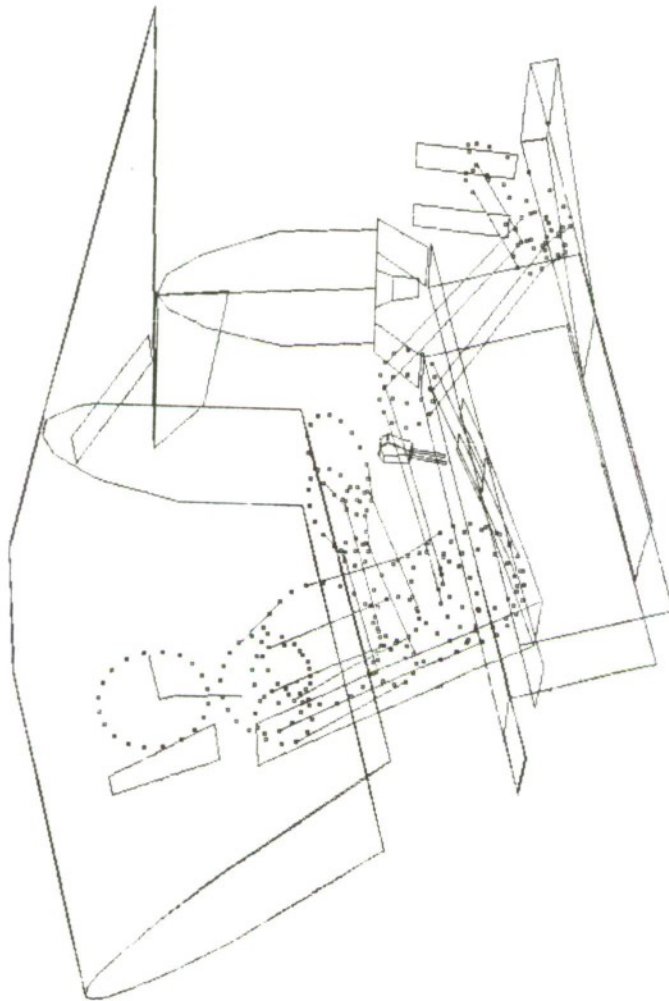

Figure 27. ON-LINE PLOT Function. Message "PLOTTING" Displayed When Plotting is Done on the GOULD Plotter.

### 2.2.9 ON-LINE PLOT COMBIMAN Function (PFK8)

The ON-LINE PLOT COMBIMAN function generates on-line plots of the man-model and crew station configuration currently shown in the Display Area of the screen. After depressing the ON-LINE PLOT function key (PFK8), the user has the option of selecting a perspective or a nonperspective plot (see Paragraph 2.2.8). The program displays the message "PERSPECTIVE PLOT? ENTER Y/N" in the Prompting Area of the CRT. The user must respond "Y" or "YES" for a perspective plot, or "N" or "NO" for a nonperspective plot, from the ANKB (see Figure 25).

The program then displays the message "ENTER PLOT SCALE FACTOR" in the Prompting Area of the CRT (see Paragraph 2.2.8). To enter the scale factor, the decimal value is typed using the ANKB and is followed by the ALT-CODE/5 sequence (see Figure 26). When a valid scale factor (greater than 0.0) is entered the program displays the message "PLOTTING" in the Information Area of the CRT (see Figure 27), and a hard copy plot is generated. Note that the scale factor is applied to the display image size for perspective plots, and to the full scale coordinates for nonperspective plots. A sample on-line perspective plot is shown in Figure 28.



```

REGRESS: R67 USAF
SURVEY: 67 USAF
CRST:  A7E-01
VIEW-PLANE: OFF AXIS
ROLL   PITCH   YAW
0.0   -15.0   15.0
PERSPECTIVE
SCALE=1.00

```

Figure 28. ON-LINE PLOT Function. A Sample Perspective On-Line Plot.

### 2.2.10 PRINT DATA Function (PFK9)

The PRINT DATA function prints man-model and crew station data. The man-model data consist of, for each link, the X, Y, and Z coordinates of the distal end of each link, the transformation angles for each link, and the enfleshment semi-axes lengths.

Data for the displayed crew station panels consist of the name, type, and X, Y, and Z coordinates of all the vertices. The coordinates of each control on the displayed crew station together with its name and name of the panel it is located on, if any, are also printed. An example of the output generated by the PRINT DATA function is shown in Figure 29.

COMBIMAN LINK DATA

SURVEY DATA IS AT USAF

NO.	NAME	DISTAL END			JOINT ANGLES			SEMI AXIS LENGTHS		
		X	Y	Z	PHI	THETA	PSI	ALPHA	BETA	GAMMA
0	SRP	0.0	0.0	0.0	0.0	0.0	0.0	0.0	0.0	0.0
1	SRP-WHIP	4.54	0.0	3.41	0.0	53.70	0.0	4.53	7.41	4.58
2	STOMACH	2.87	0.0	8.26	0.0	-74.20	0.0	4.37	6.07	4.37
3	CHEST	0.26	0.0	17.37	0.0	4.80	0.0	4.81	6.43	4.81
4	LWR NECK	-0.48	0.0	24.82	0.0	10.00	0.0	3.61	8.01	3.61
5	UPR NECK	0.80	0.0	29.87	0.0	20.00	0.0	0.0	0.0	0.0
6	MID PEAC	0.80	0.0	31.28	0.0	-14.30	0.0	3.88	3.04	4.47
7	MH-MEYE	4.14	0.0	31.28	0.0	90.00	0.0	0.0	0.0	0.0
8	MEYE-MEY	4.14	-1.25	31.28	0.0	90.00	0.0	0.0	0.0	0.0
9	MEYE-LEY	4.14	1.25	31.28	0.0	90.00	0.0	0.0	0.0	0.0
10	LN-MIDSS	2.56	0.0	23.76	0.0	115.00	0.0	0.0	0.0	0.0
11	MSS-RSS	2.56	-1.00	23.76	0.0	90.00	29.30	0.0	0.0	0.0
12	RSS-RSLD	-1.14	-8.01	21.44	0.0	-31.90	-112.00	2.31	2.30	2.07
13	RSLDR	-1.14	-8.01	10.66	0.0	-90.00	-90.00	1.73	1.73	1.73
14	RUPARM	0.76	-8.01	12.51	0.0	90.00	0.0	1.10	1.10	1.10
15	RLWARM	13.13	-8.01	12.86	0.0	0.0	0.0	2.01	0.54	3.76
16	RGRIPCTR	15.78	-8.01	13.33	0.0	0.0	0.0	0.0	0.0	0.0
17	KFRCH	16.57	-8.01	13.82	0.0	0.0	0.0	0.0	0.0	0.0
18	RFRNRTIP	2.56	1.00	23.76	0.0	90.00	-29.30	0.0	0.0	0.0
19	MSS-LSS	-1.14	8.01	21.44	0.0	-31.90	112.00	2.31	2.30	2.07
20	LSS-LSLD	-1.14	8.01	10.68	0.0	-90.00	90.00	1.73	1.73	1.73
21	LSLDR	0.76	8.01	12.51	0.0	90.00	0.0	1.10	1.10	1.10
22	LUPARM	11.16	8.01	12.86	0.0	0.0	0.0	2.01	0.54	3.76
23	LLWARM	13.13	8.01	13.33	0.0	0.0	0.0	0.0	0.0	0.0
24	LGRIPCTR	15.78	8.01	13.82	0.0	0.0	0.0	0.0	0.0	0.0
25	LFRCH	16.57	8.01	13.82	0.0	0.0	0.0	0.0	0.0	0.0
26	LFNRTIP	4.64	-3.43	3.41	0.0	90.00	53.70	3.24	3.24	4.10
27	MHIP-KHP	21.53	-3.43	5.48	0.0	90.00	-50.00	2.16	2.16	2.16
28	RUPRLEG	31.25	-3.43	-7.42	0.0	60.00	0.0	1.40	1.40	1.40
29	KLWRLEG	32.58	-3.43	-9.18	0.0	0.0	0.0	5.32	1.92	1.28
30	RHK-KRKH	4.64	3.43	3.41	0.0	90.00	-53.70	3.24	3.24	4.10
31	MHIP-LHP	21.53	3.43	5.48	0.0	90.00	90.00	2.16	2.16	2.16
32	LUPRLEG	31.25	3.43	-7.42	0.0	60.00	0.0	1.40	1.40	1.40
33	LLWRLEG	32.58	3.43	-9.18	0.0	0.0	0.0	5.32	1.92	1.28
34	LHK-LPKH	4.64	3.43	3.41	0.0	90.00	53.70	3.24	3.24	4.10

Figure 29. Output for COMBIMAN PRINT Function.

### 2.2.11 PERFORM REACH ANALYSIS Function (PFK11)

The PERFORM REACH ANALYSIS function causes the man-model to attempt an arm reach to a selected point in space.

First, the program prompts the user to light-pen REACH MOBILITY: ARM, LAP, or SHOULDER as shown in Figure 30. ARM mobility allows only arm movement while the shoulder and torso remain fixed. LAP mobility allows arm, shoulder, and torso movement. SHOULDER mobility allows arm and shoulder movement while the torso remains fixed. After the reach mobility has been selected the program prompts the user to light-pen the REACH TYPE (see Figure 31). There are two reach types, right arm (RARM) and left arm (LARM). After the reach type has been selected, the program prompts the user to light-pen the EXTENT OF REACH. There are three choices: grip center (GRIPCTR) which indicates a grasping motion such as for a control stick, functional (FUNCTRCH) which indicates a pinching motion such as for turning a knob, and finger tip (FNGRTP) which indicates a touching motion, such as for a push button (see Figure 32). Figure (1) shows the relative locations of these points on the hand. The shape of the hand on the man-model remains the same regardless of which grip type is selected. Once the extent of reach type has been selected, the program displays the man-model/crew station configuration in the X-Z plane (side view) in a nonperspective view (see Paragraph 2.2.8). The program then prompts the user to position the cross symbol ("+") at the point to be reached within the display area. The program uses a slewable "+" to locate and designate the 3-D coordinates of points of interest on the displayed image.

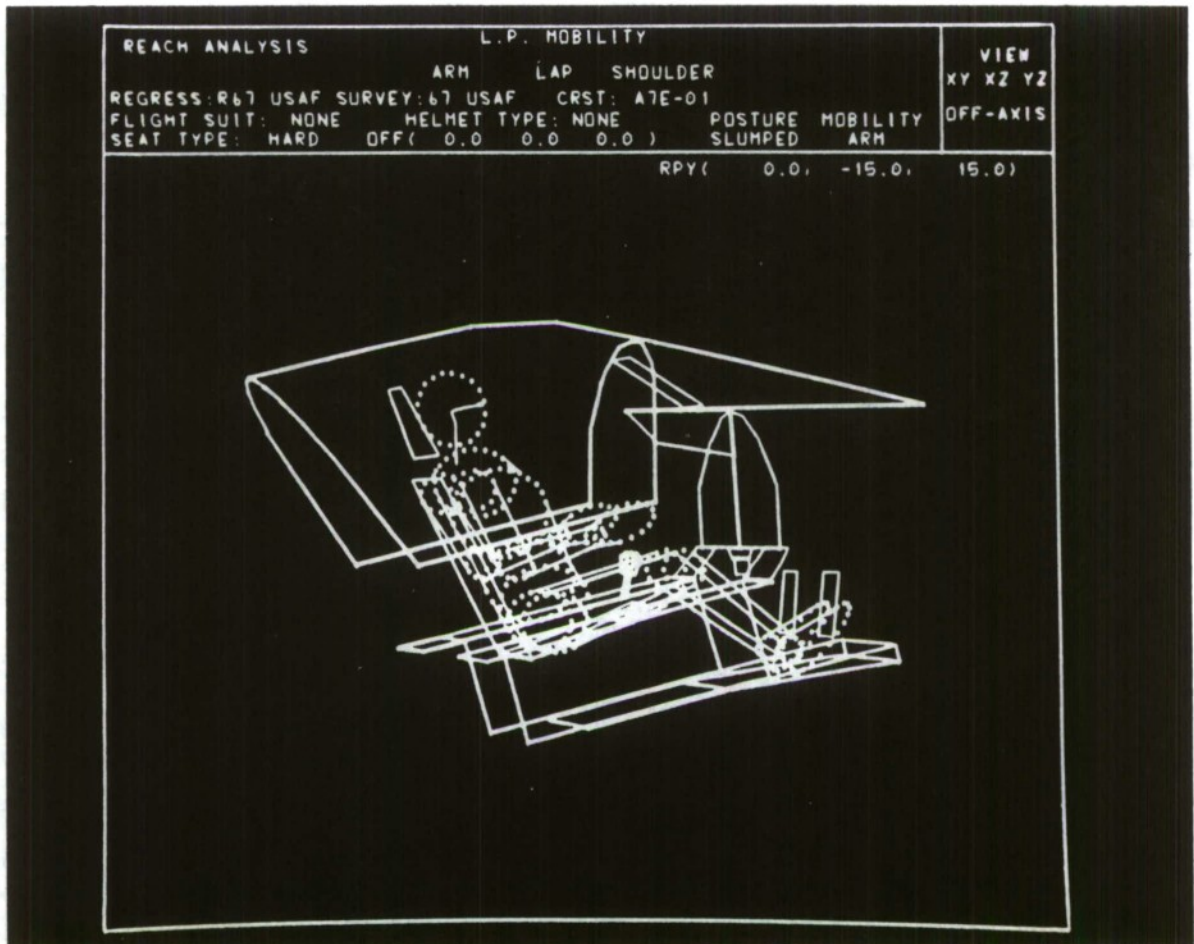

Figure 30. PERFORM REACH ANALYSIS Function.  
First message "L.P. MOBILITY".

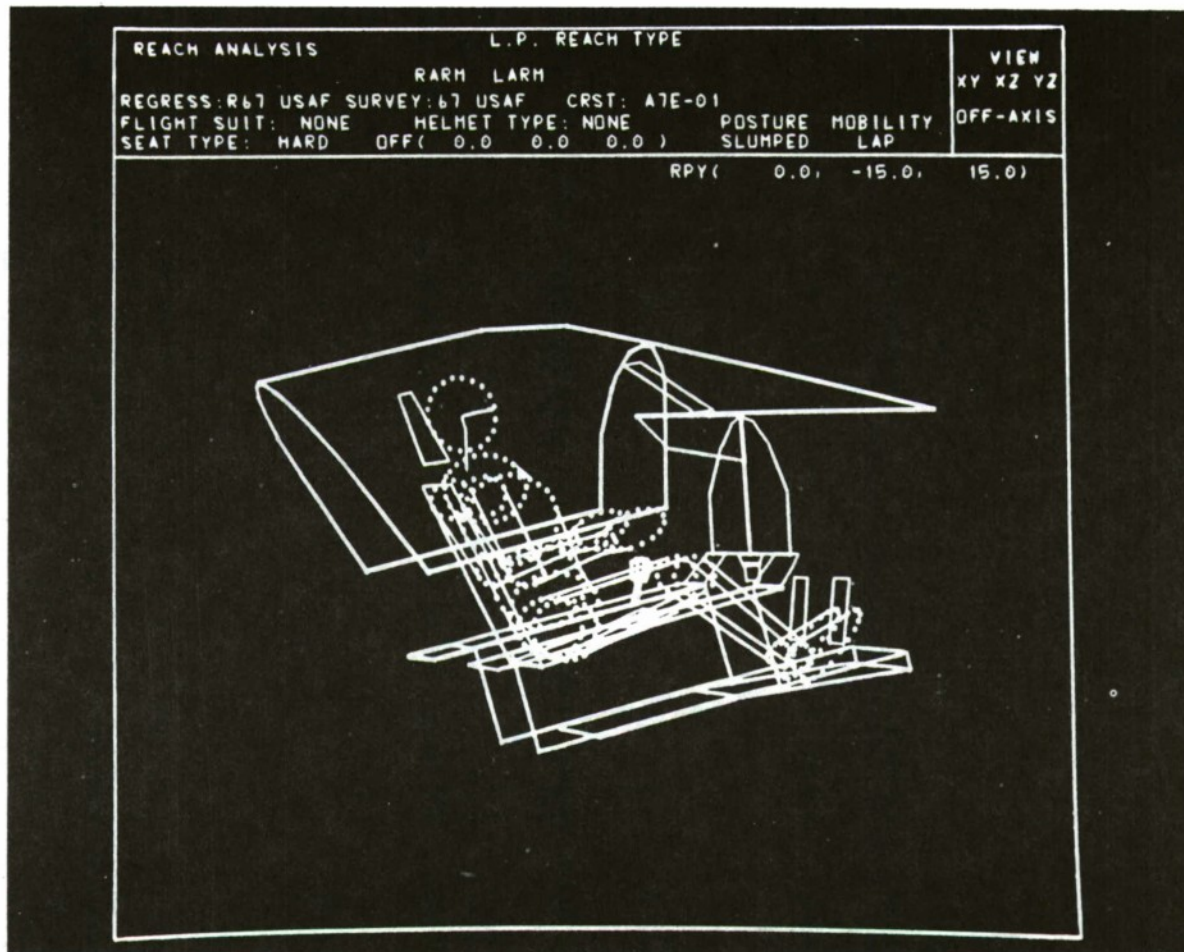

Figure 31. PERFORM REACH ANALYSIS Function Light Pen Reach Type.

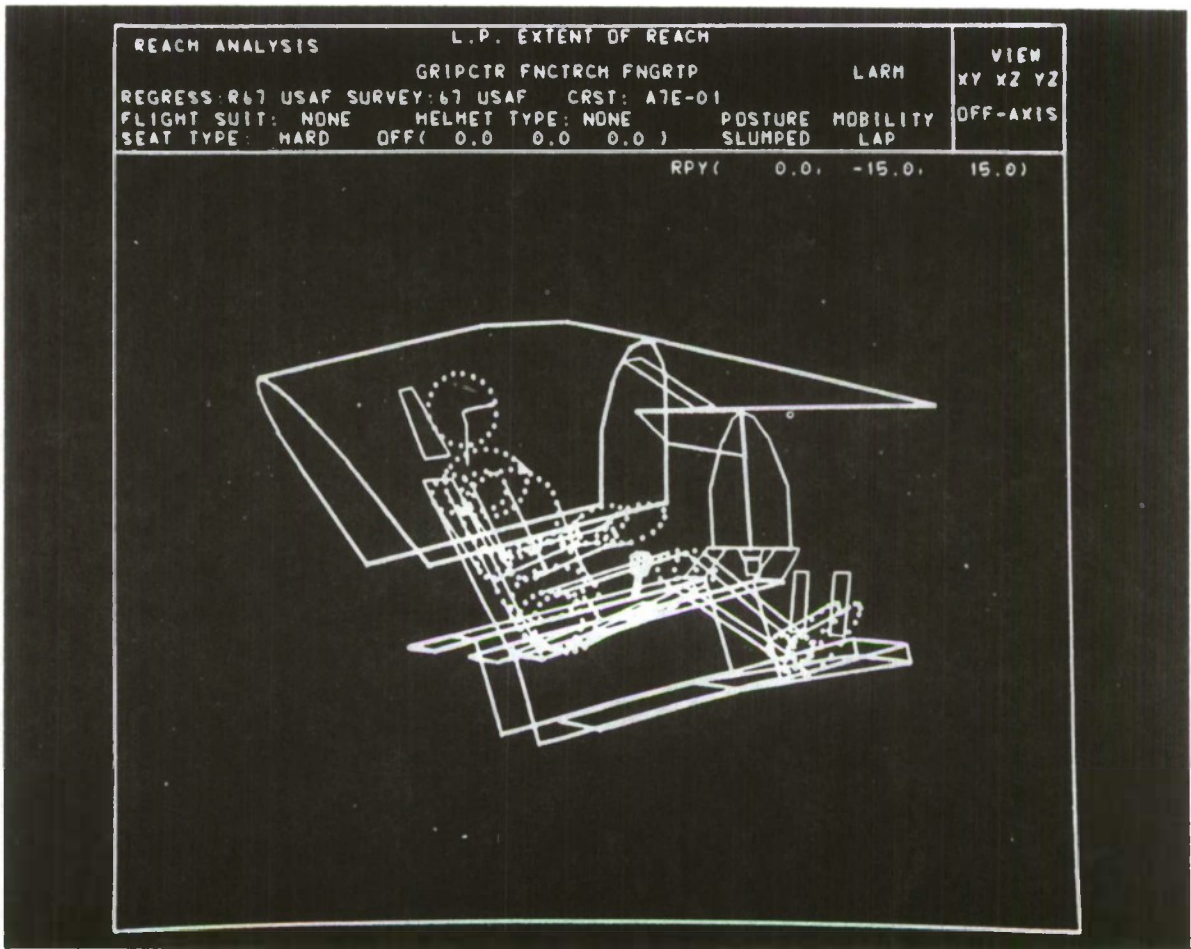

Figure 32. PERFORM REACH ANALYSIS Function Light Pen  
Extent of Reach.

### 2.2.11.1 Positioning the Cross Symbol "+"

Initially, the program displays a cross symbol ("+") at the seat reference point (SRP) as shown in Figure 33. The user must first position the "+" in the X-Z plane (side view) to define the X and Z coordinates, and then in the Y-Z plane (front view) to define the Y-coordinate of the reach point. Note that the Z-coordinate can be redefined while positioning the cross in the Y-Z plane. Figures 34 and 35 show the man-model in X-Z and Y-Z planes respectively with the "+" at a point to be reached on the instrument panel. The "+" is precisely positioned on a point using the Program Function Keyboard as described in the following paragraphs.

The PFKs are temporarily redefined as shown in Figure 36. The direction and magnitude of movement of "+" on the screen when these PFKs are depressed are indicated inside the circles representing the PFKs in the figure. By selecting the proper PFK, the "+" can be moved up, down, left, right, or combinations of these, at two different speeds. For example, depressing PFK7 causes the "+" to move up and right in one inch increments at a rate of approximately 25 steps per second.

Once in motion, the direction and/or magnitude of movement of the cross can be changed simply by depressing another directional PFK. The motion may be stopped by depressing the STOP/RECORD key (PFK12) once, or depressing the SINGLE STEP ON key (PFK26). After depressing the STOP key, motion can be continued by selecting any other key. As soon as the cross is near the desired point, depress the SINGLE STEP ON key (PFK26). This stops automatic motion of the cross, allows the cross to be moved in single steps of 0.1 or 1.0 inch each time a directional key is depressed. In this way, the cross

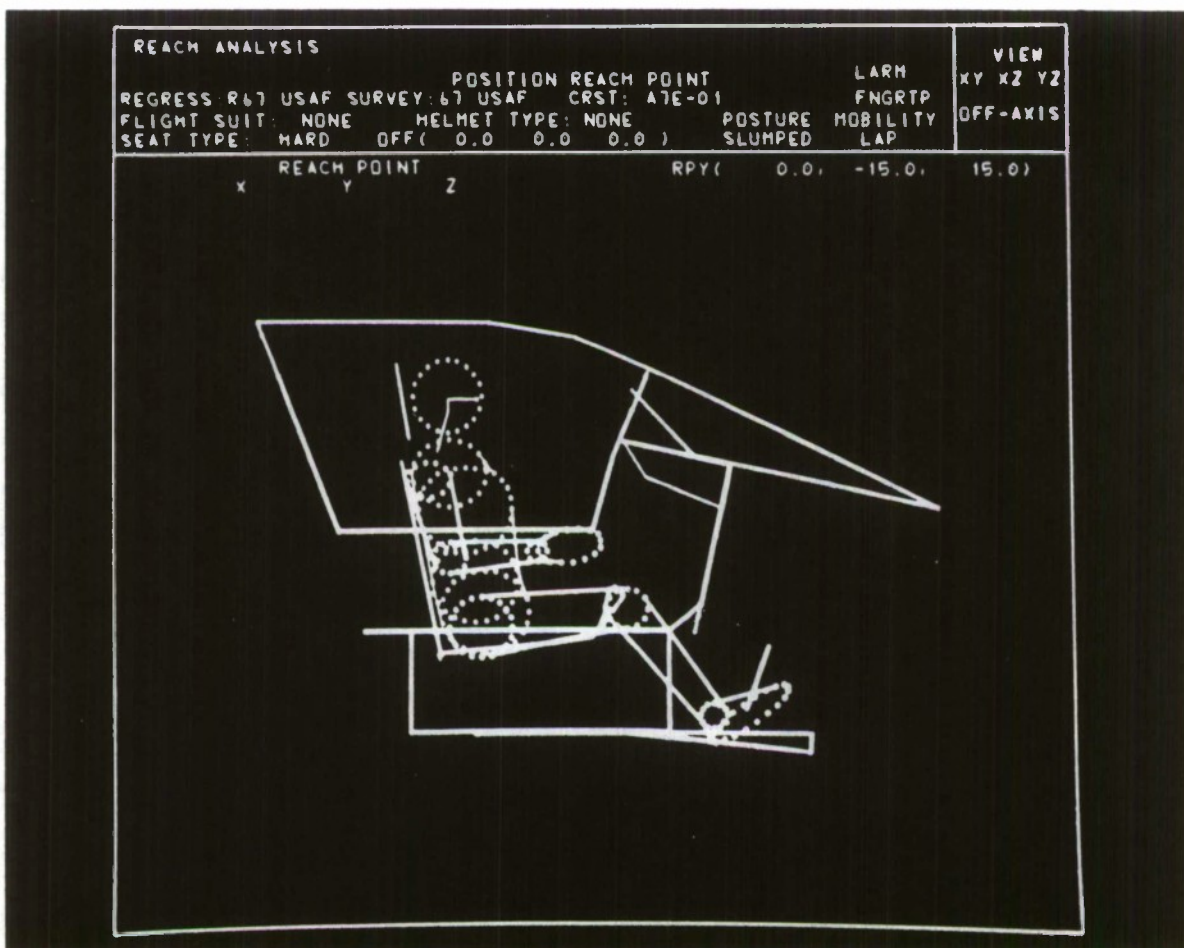

Figure 33. Positioning Cross Symbol "+" Initially the Cross Symbol is Displayed at the SRP.

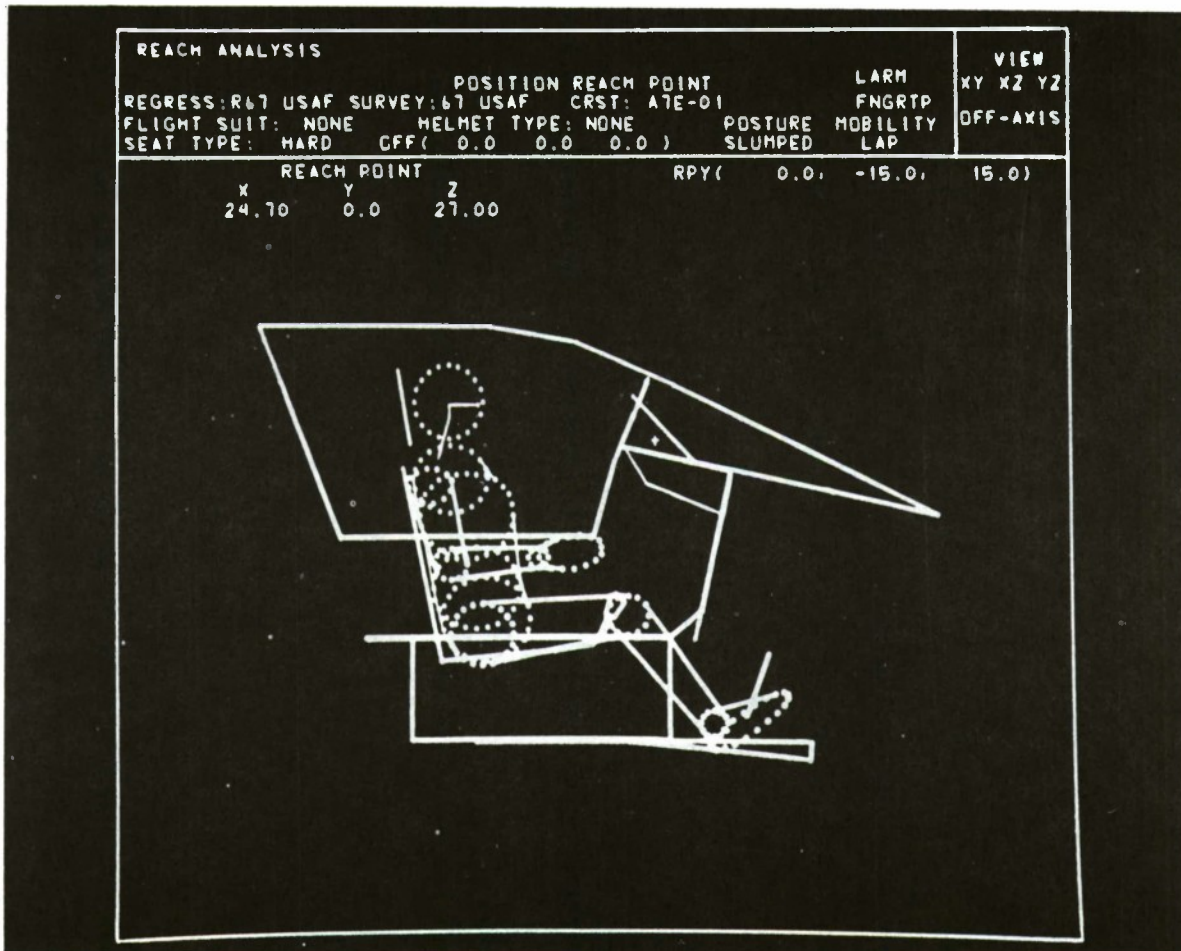

Figure 34. Side View (X-Z Plane) - the "+" Symbol Locates the Reach Point. The X and Z Coordinates are Defined in this View Note the Coordinates Displayed in the Upper-Left Hand Display Area.

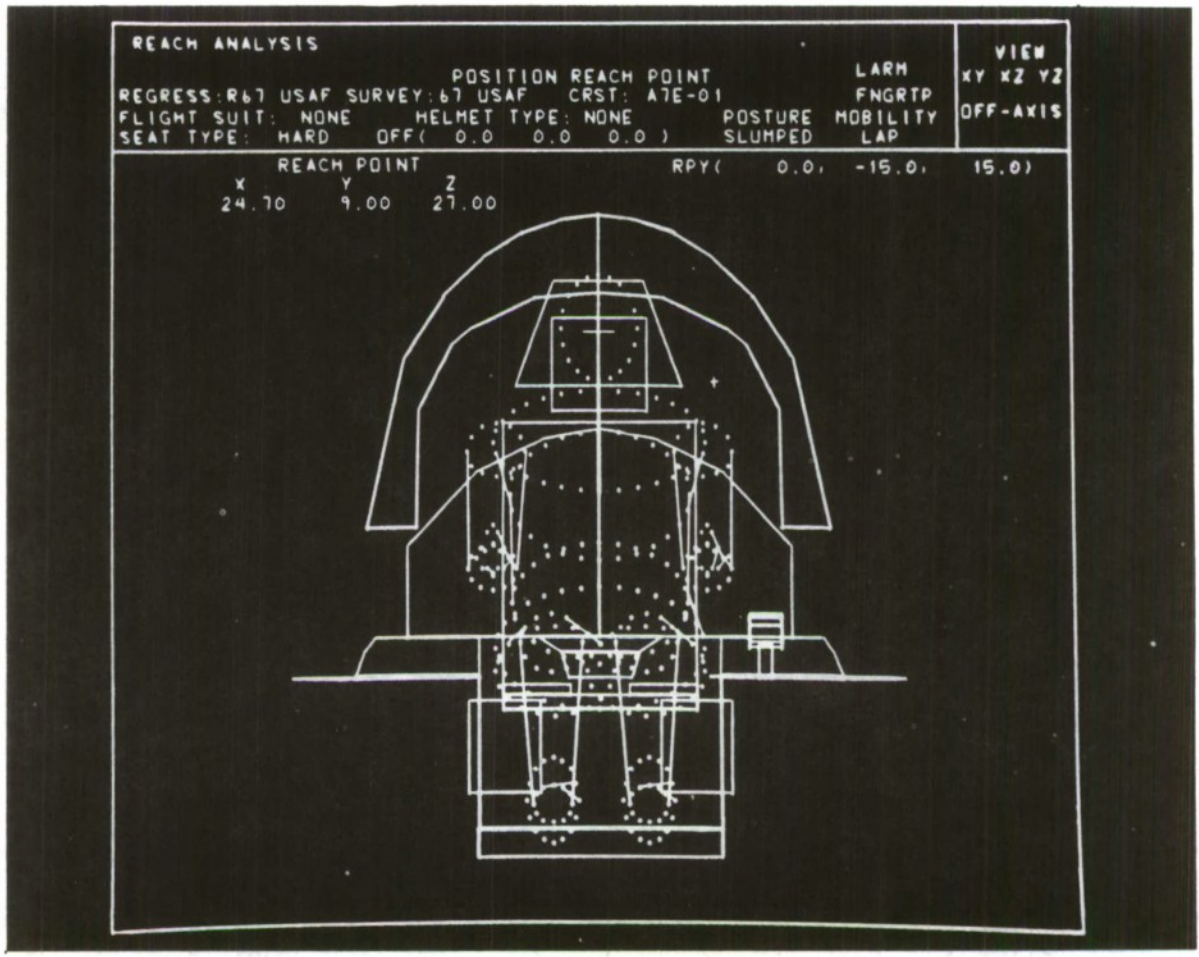
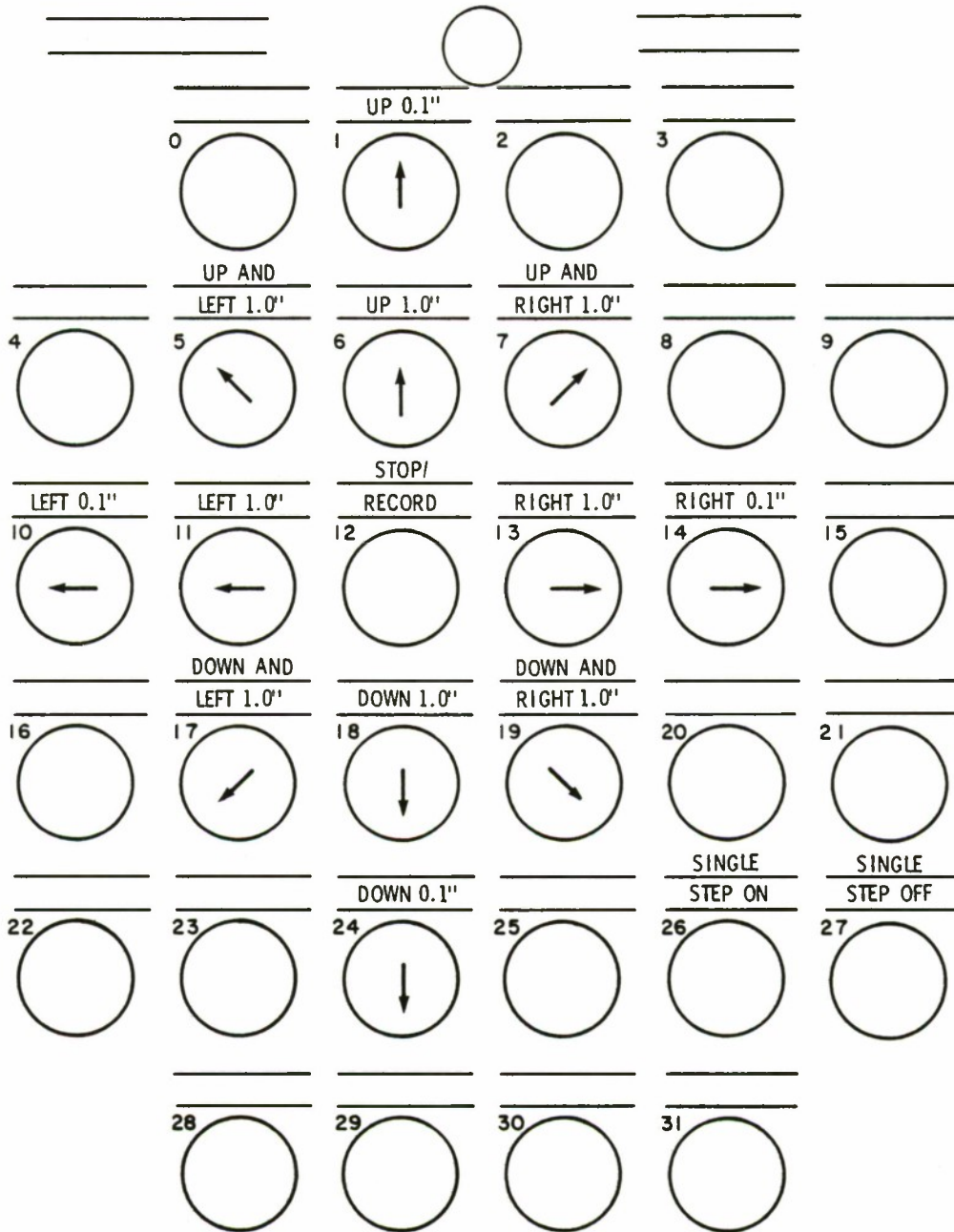

Figure 35. Front View (Y-Z Plane). The "Cross" Symbol is Used to Define the Y Coordinate. The Z Coordinate May Also be Redefined in this View.



IBM

Figure 36. Redefined Program FUNCTION Keys for Positioning the "+" Symbol.

may be positioned precisely by (1) monitoring the position of the cross relative to the displayed image, or (2) monitoring the X, Y, Z Coordinate Readout (see Figure 34) which appears in the upper-left part of the Display Area when this function is in progress. This latter method is to be used when the coordinates of the point are known. Note that these coordinates are in the Seat Reference Point coordinate system. Also note that this is different from the NSRP (Neutral Seat Reference Point) coordinate system used to displace the seat in the SEAT ADJUST function.

To locate and enter a 3-D coordinate set proceed as follows:

- When the "+" is to be used to locate a point, the display automatically transitions to a side view (XZ plane).
- Move the cross to the desired location in the side view by the method described above.
- Depress the STOP/RECORD key (PFK12) twice in succession to enter the X coordinate.
- The display automatically transitions to a front view (YZ plane).
- Use the left or right direction keys to position the cross in the Y direction.

NOTE: If the cross is moved up or down, the Z coordinate is redefined.

- Depress the STOP/RECORD key (PFK12) twice in succession to enter the Y and Z coordinates.
- The display automatically transitions to the orientation in use at the time the PERFORM REACH function was activated.

Now the PFKs are reset to their original definition and the man-model begins to reach toward the specified point in three to six discrete steps. When the reach is successful, "REACH SUCCESSFUL" is displayed in the Information Area of the display as shown in Figure 37. If the man-model could not reach the point, the message "MISS DISTANCE" and the miss distance value in inches are displayed in the Information Area of the CRT display as shown in Figure 38.

#### 2.2.11.2 Post Reach Processing

Following the reach, the user must light-pen the response "YES" or "NO" displayed below the prompting message "PRINT REACH DATA? L.P. YES OR NO" (see Figures 37 or 38). If the user's response is "YES", a summary of the reach analysis as shown in Figure 39 is printed out. There will be no printed output if the user light pens "NO".

The message "CONTINUE REACH? L.P. YES OR NO" is then displayed in the Prompting Area of the CRT screen. If the user wants to continue the reach analysis with the same arm or have a two arm reach, the light-pen response must be "YES". In this case the program restarts the reach routine and prompts the user to light-pen the reach type (see Paragraph 2.2.11). If the user desires a two arm reach, "LARM" must be light-penned if the first choice was "RARM" and vice versa. When a two arm reach is executed, the first reach determines the position of the shoulder and trunk. The reach by the other arm is an "ARM ONLY" type of reach, with no shoulder or trunk movement. If the user light-pens "NO" the program progresses to display the next message "RESET POSTURE? L. P. YES OR NO". If the user light-pens "YES" the program resets the man-model to the posture before the reach attempt. If the user light-pens "NO" the man-model remains in the reaching posture. At this point the reach routine returns control to the main program.

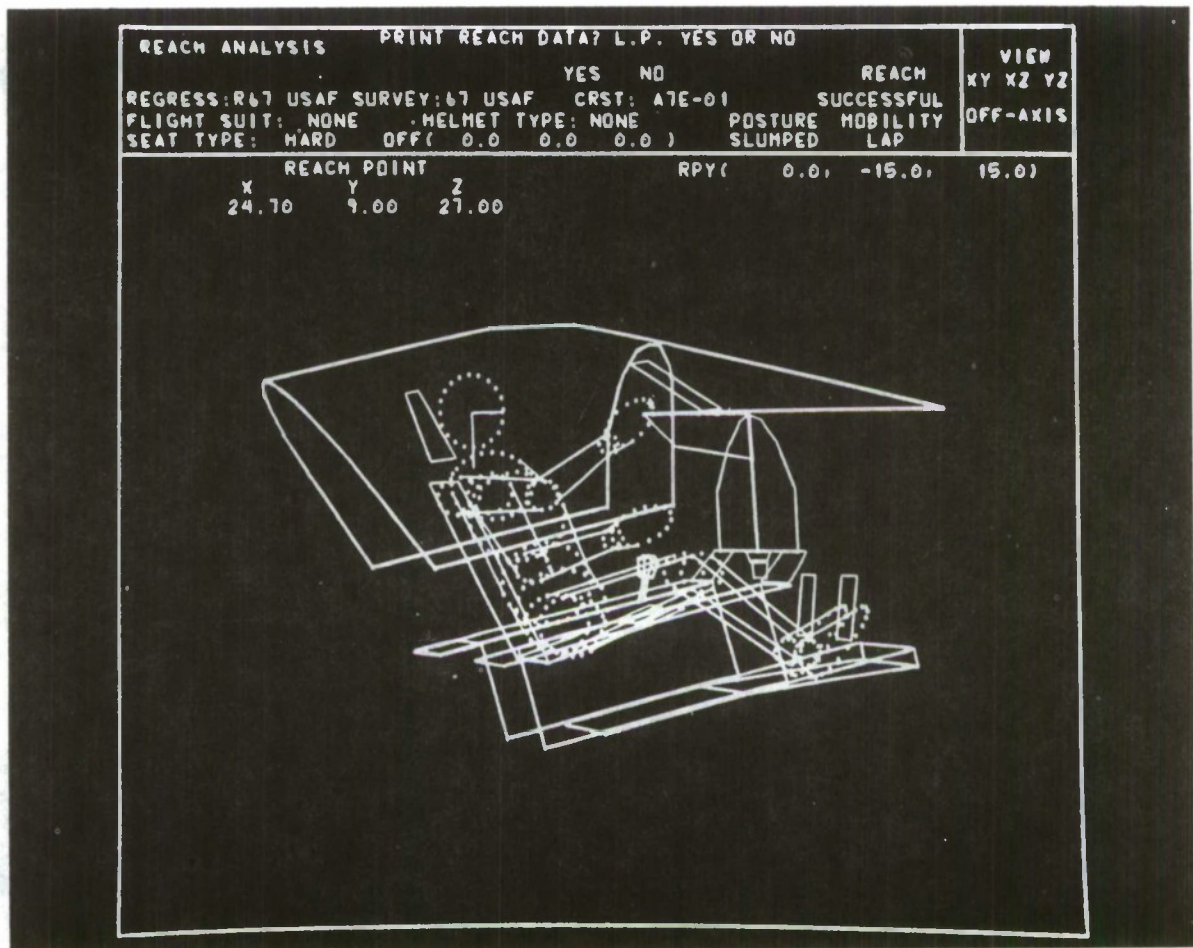

Figure 37. REACH SUCCESSFUL is Displayed after the Reach is Successfully Performed.

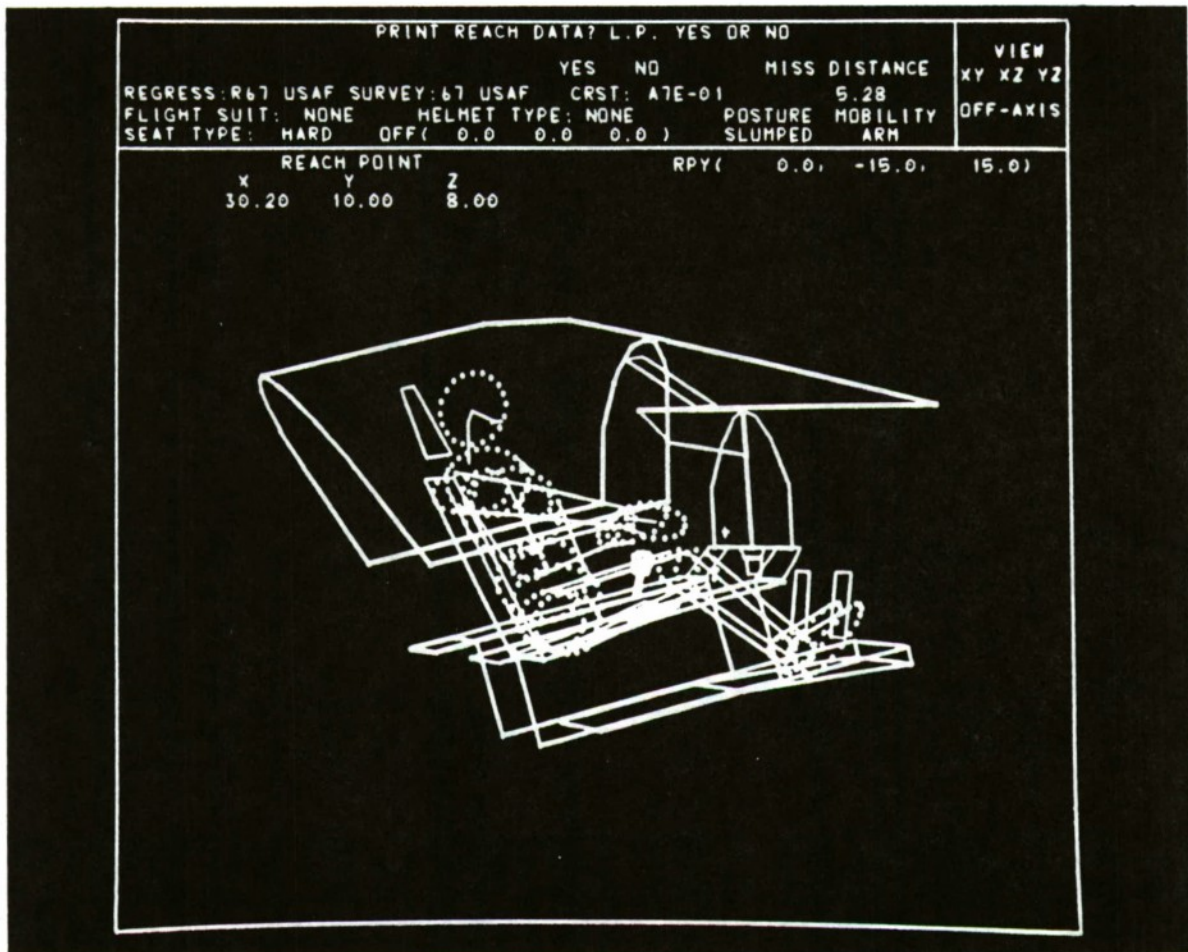

Figure 38. MISS DISTANCE is Displayed if the Man-Model Could Not Reach the Point.

-----  
 COMBIMAN REACH ANALYSIS  
 -----

----- RCH NO. -----	----- RCH TYPE -----	----- RCH PT. -----	----- DIST. TO RCH PT. -----	----- POSTURE -----	----- MOBILITY -----
1	1 LEFT ARM	( 27.00, 5.00, 27.00)	0.00	SLUMPED	LAP

Figure 39. PERFORM REACH Function Printout Obtained When User Responds "YES" to Message "PRINT REACH DATA? L.P. YES or NO".

2.2.12 INPUT 12 ANTHROPOMETRIC DIMENSIONS Function  
(PFK12)

This is one of two methods to define the bodysize of the man-model. The other method is described in Paragraph 2.2.13. The INPUT 12 ANTHROPOMETRIC DIMENSIONS function allows the user to supply values, either as percentiles or as absolute dimensions, for each of the dependent anthropometric variables necessary to construct the link system of the man-model. This function can be selected by depressing PFK12.

There are basically three methods for entering anthropometry using this function: (1) in engineering units with card input, (2) in engineering units through the ANKB, or (3) by selecting a percentile for each variable from a menu on the display.

1) If State Switch 22 is previously set "ON", the message "CARD INPUT ANTH.DIM.? ENTER Y/N" is displayed in the Prompting Area of the CRT. If the answer is "YES" or "Y" through the ANKB, the 12 dependent anthropometric dimensions are read, in the default units of measure, from input cards in the format shown in Figure 40. The function then returns control to the main routine to generate the man-model. If the response is "NO" or "N", or simply the ALT-CODE/5 sequence, or if State Switch 22 is not set "ON" the program bypasses the card input option.

2) When the card input option is bypassed, the message "VALUES IN PCTLS? ENTER Y/N" is displayed in the Prompting Area of the CRT. If the response through the ANKB is "NO" or "N" to this message, the user is then prompted to enter a value in engineering units for each of the 12 dependent variables. The procedure is as follows:

128.034.5722.8420.7523.0314.2115.9112.409.02 10.087.44 11.58  
140.035.8323.3923.0724.6516.1815.9513.988.82 11.307.84 12.63  
147.034.2921.6920.4722.6 12.4415.2013.509.61 9.92 7.13 10.90  
152.035.6324.1320.8723.2314.4515.4713.159.80 10.837.36 11.50  
159.035.7924.2121.6124.0614.6115.5113.749.33 10.167.40 11.99  
164.037.0924.6521.6523.5813.8616.3413.359.76 10.397.52 11.58  
172.038.1525.2022.1724.7613.9016.8113.789.41 10.557.56 11.58  
181.038.2724.9222.8324.6514.4917.4413.7410.9110.517.68 12.01  
187.037.3623.7023.1925.8314.8816.3014.379.57 11.308.19 12.87  
196.037.0524.4122.5625.5914.5317.0915.0 10.5910.877.99 12.19  
202.036.0223.4724.8426.7715.9416.5415.5510.7111.508.23 12.64  
211.036.1424.0622.0924.8814.7617.1314.8011.6511.187.72 11.97  
221.039.0226.0222.6025.3515.2016.6514.7210.4310.717.76 11.77  
228.039.3325.7922.9925.0 14.3716.4215.3911.0611.307.76 12.99  
145.033.9421.3420.3522.7612.9915.8312.959.02 9.65 6.93 10.39  
149.034.2521.4621.1023.2713.7015.5913.0310.5110.127.24 11.34  
163.034.6922.3621.6123.7413.7816.3013.709.88 9.21 7.01 11.30  
164.035.1223.1920.3222.3613.9016.0613.9810.1210.477.28 10.91  
150.035.3922.8019.6521.2613.2715.9113.079.57 10.287.09 10.71  
140.035.8323.3923.0724.6516.1815.9513.988.82 11.307.84 12.64  
175.036.1824.6520.7123.4314.6916.0614.310.1210.0 7.32 11.65  
179.036.6524.2921.3423.9013.9815.9514.6110.6710.477.13 11.77  
171.037.1723.1522.1323.3514.2116.7714.6510.1210.957.68 11.44  
173.037.5224.0622.8724.2914.7617.8014.029.84 10.718.07 12.24  
188.037.9925.3223.2324.8015.0 16.3014.4110.2810.957.60 12.60  
177.038.3524.6922.7625.5915.4315.8713.908.98 11.187.95 11.81  
192.038.8225.3922.8724.9215.2017.3214.659.88 11.147.64 11.93  
160.039.2926.1422.6823.1114.5316.8912.878.39 11.027.87 11.93  
184.039.6125.2023.2324.6514.8416.3813.709.21 11.267.64 12.07  
133.035.1222.5621.3822.6 13.7814.5313.278.03 10.327.56 11.46

Figure 40. DATA SET - COMBIMAN.SMPLANTH (Card Image). Each Card  
Contains 12 Independent Anthropometric Variable in F5.2  
Format to Create a Man-Model.

- The message "DESIRE CHANGE UNIT? ENTER Y/N" will be displayed. The user types "YES" or "Y" and follows the ALT/CODE-5 sequence to change the units for each variable. If the response is "NO" or "N" followed by ALT/CODE-5 sequence, or simply ALT/CODE-5 sequence, the default units are assumed.

NOTE: While value may be entered in any units of measure, they are converted to pounds or inches for processing, display, and printouts.

- The first variable name is then underlined.
  - If the response to the above prompting message is "YES" as shown in Figure 41 then the message "L.P. NEW UNIT, IF DESIRED" is displayed as shown in Figure 42. The user may light pen a new unit from the menu of allowable units (in, cm, mm, lb, or kg), or perform ALT-CODE/5 sequence to retain the default unit for that variable. Then the message "ENTER NEW VALUE" appears in the Prompting Area as shown in Figure 43. The process repeats for each variable (see Figure 44).
  - If the response to the prompting message "DESIRE UNIT CHANGE? ENTER Y/N" is "NO", the message "ENTER NEW VALUE" immediately appears in the Prompting Area of the CRT.
- The user types in the numeric quantity in the appropriate units followed by the ALT-CODE/5 sequence. The process then repeats as each of the 12 dependent variable names is underlined. Control is then returned to the main routine for man-model generation.

NOTE: Since the unit of measurement is declared for each number entered, the numbers need not be in the same units, that is, inches, centimeters, and millimeters; and pounds and kilograms. These units may be mixed as desired. Alternatively, since pounds and inches are the default units of measure, the user may select these by using the ALT-CODE/5 sequence rather than using the light pen.

		DESIRE CHANGE UNIT? ENTER Y/N	
		MEMBER 67 USAF ACCEPTED	
DEPENDENT	VBLS UNIT	INPUT	
			AVBL UNITS    AVBL PCTL
WEIGHT	LB		IN            1
SITTING HEIGHT	IN		CM            2
ACROMION HGT/SIT	IN		MM            3
KNEE HGT/SITTING	IN		LB            5
BUTTOCK-KNEE LGTH	IN		10
SHOULDR-ELB LGTH	IN		15
BIACROMIAL BRDTH	IN		20
HIP BREADTH	IN		25
CHEST DEPTH	IN		30
FOOT LENGTH	IN		35
HAND LENGTH	IN		40
ELBOW-WRIST LGTH	IN		45
			50
			55
			60
			65
			70
			75
			80
			85
			90
			95
			99

Figure 41. INPUT 12 ANTHROPOMETRIC DIMENSIONS Function Option to Change Input Unit When Entering Values in Engineering Units.

L.P. NEW UNIT, IF DESIRE  
 MEMBER 67 USAF ACCEPTED

DEPENDENT VBL	UNIT	INPUT	AVBL UNITS	AVBL PCTL
WEIGHT	LB		IN	1
SITTING HEIGHT	IN		CM	2
ACROMION-HGT/SIT	IN		MM	3
KNEE HGT/SITTING	IN		MM	5
BUTTOCK-KNEE LGTH	IN		LB	10
SHOULDR-ELB LGTH	IN		LB	15
BIACROMIAL BRDTH	IN		KG	20
HIP BREADTH	IN			25
CHEST DEPTH	IN			30
FOOT LENGTH	IN			35
HAND LENGTH	IN			40
ELBOW-WRIST LGTH	IN			45
				50
				55
				60
				65
				70
				75
				80
				85
				90
				95
				97
				98
				99

Figure 42. INPUT 12 ANTHROPOMETRIC DIMENSIONS Function  
 Choose New Unit for Input Value.

		ENTER NEW VALUE			
		MEMBER	70	67 USAF	ACCEPTED
DEPENDENT	VBLS UNIT	INPUT	AVBL UNITS	AVBL PCTL	
WEIGHT	----- KG		IN	1	
SITTING HEIGHT	IN		CM	2	
ACROMION HGT/SIT	IN		MM	3	
KNEE HGT/SITTING	IN		LB	10	
BUTTOCK-KNEE LGTH	IN		KG	15	
SHOULDR-ELB LGTH	IN			20	
BIACROMIAL BRDTH	IN			25	
HIP BREADTH	IN			30	
CHEST DEPTH	IN			35	
FOOT LENGTH	IN			40	
HAND LENGTH	IN			45	
ELBOW-WRIST LGTH	IN			50	
				55	
				60	
				65	
				70	
				75	
				80	
				85	
				90	
				95	
				97	
				98	
				99	

Figure 43. INPUT 12 ANTHROPOMETRIC DIMENSIONS Function  
Sample Input in Engineering Unit.

L.P. NEW UNIT, IF DESIRE  
 MEMBER 67 USAF ACCEPTED

DEPENDENT VBL	UNIT	INPUT	AVBL UNITS	AVBL PCTL
WEIGHT	KG	70.00	IN	1
SITTING HEIGHT	IN	32.50	CM	2
ACROMIOM-HGT/SIT	IN		MM	3
KNEE HGT/SITTING	IN		LB	5
BUTTOCK-KNE LGTH	IN		KG	10
SHOULDR-ELB LGTH	IN			15
BIACROMIAL BRDTH	IN			20
HIP BREADTH	IN			25
CHEST DEPTH	IN			30
FOOT LENGTH	IN			35
HAND LENGTH	IN			40
ELBOW-WRIST LGTH	IN			45
				50
				55
				60
				65
				70
				75
				80
				85
				90
				95
				97
				98
				99

Figure 44. INPUT 12 ANTHROPOMETRIC DIMENSIONS Function  
 Choose New Unit, if Necessary, for the Next  
 Input Variable.

3) If the card input option is bypassed and the user responds "YES" or "Y" or simply ALT-CODE/5 to the prompting message "VALUE IN PCTLS? ENTER Y/N", (see Figure 45) values are entered for each of the 12 dependent variables as a percentile of the survey chosen in the first step of the Define Anthropometry function as follows.

- The first variable name is underlined and the user receives the prompt "L.P. PERCENTILE".
- The user then light pens the desired percentile from the menu of available percentiles on the right side of the Display Area. The above procedure is repeated for each of the 12 dependent variables. Figure 46 shows the Display after defining the first two variables. Control then returns to the main program for man-model generation.

VALUES IN PCTLS? ENTER Y/N  
 Y  
 MEMBER 67 USAF ACCEPTED

DEPENDENT VBL	UNIT	INPUT	AVBL UNITS	AVBL PCTL
WEIGHT	LB		IN	1
SITTING HEIGHT	IN		CM	2
ACROMION HGT/SIT	IN		MM	3
KNEE HGT/SITTING	IN		LB	5
BUTTOCK-KNE LGTH	IN		KG	10
SHOULDR-ELB LGTH	IN			15
BIACROMIAL BRDTH	IN			20
HIP BREADTH	IN			25
CHEST DEPTH	IN			30
FOOT LENGTH	IN			35
HAND LENGTH	IN			40
ELBOW-WRIST LGTH	IN			45
				50
				55
				60
				65
				70
				75
				80
				85
				90
				95
				97
				98
				99

Figure 45. INPUT 12 ANTHROPOMETRIC DIMENSIONS Function Option to Choose Input Values in Percentile or in Engineering Units.

L.P. PERCENTILE				
		MEMBER	67 USAF	ACCEPTED
DEPENDENT VBL	UNIT	INPUT	AVBL UNITS	AVBL PCTL
WEIGHT	LB	95 PCT	IN	1
SITTING HEIGHT	IN	75 PCT	CM	2
ACROMIOM. HGT/SII	IN		MM	3
KNEE HGT/SITTING	IN		LB	5
BUTTOCK-KNEE LGTH	IN		KG	10
SHOULDR-ELB LGTH	IN			15
BIACROMIAL BRDTH	IN			20
HIP BREADTH	IN			25
CHEST DEPTH	IN			30
FOOT LENGTH	IN			35
HAND LENGTH	IN			40
ELBOW-WRIST LGTH	IN			45
				50
				55
				60
				65
				70
				75
				80
				85
				90
				95
				97
				98
				99

Figure 46. Light Pen Percentile Values for the INPUT 12 ANTHROPOMETRIC DIMENSIONS Functions. The first two values have been defined in percentiles; the third value is underlined, indicating its value will be defined by the next selected percentile value.

### 2.2.13 INPUT TWO INDEPENDENT VARIABLES Function (PFK13)

This is one of two methods to define the size of the man-model, the other method is described in Paragraph 2.2.12.

The INPUT TWO INDEPENDENT VARIABLES function provides the user with the opportunity to select two relevant anthropometric variables and to enter their values. One of these variables is highly correlated to the mass variables of the man-model, and the other is highly correlated to the length variables. One of the advantages of using this function is that the user need not specify values for all 12 dependent anthropometric dimensions, as with PFK12 (Paragraph 2.2.12). Instead, the user selects two key variables most relevant to the design or evaluation problem. The program will calculate values for the remaining dependent variables using regression equations. Values supplied by the user can be either in percentiles of the selected anthropometric survey member, or in engineering units.

After depressing PFK13, the CRT is formatted as shown in Figure 47. The left and center portions of the screen contain the columns of mass and length related variables, respectively. To the right of each variable name is the default or pre-defined unit of measurement. The right portion of the screen contains a column of alternative units of measurement, labeled "AVBL UNITS", and a column of percentile names, labeled "AVBL PCTL", for which values can be obtained from the selected survey member.

The program places realistic constraints on the second variable, so the variable chosen first must be the most important one. For example, if the length dimension is more

ENTER NEW Z-SCORE							
1.65							
MEMBER 67 USAF ACCEPTED							
INDEPENDENT VARIABLES							
MASS RELATED	UNIT	INPUT	LENGTH RELATED	UNIT	INPUT	AVBL UNITS	AVBL PCTL
WEIGHT	LB		SITTING HEIGHT	IN		IN	1
BIDELTIOD BRDTH	IN		EYE HGT/SITTING	IN		CM	2
HIP BREADTH/SITT	IN		KNEE HGT/SITTING	IN		MM	3
CHEST DEPTH	IN		BUTTOCK-KNEE LGTH	IN		LB	5
			ELBOW-GRIP LGTH	IN		KG	10
			THUMB-TIP REACH	IN			15
							20
							25
							30
							35
							40
							45
							50
							55
							60
							65
							70
							75
							80
							85
							90
							95
							97
							98
							99

Figure 47. INPUT TWO INDEPENDENT VARIABLES Function Input New Z Score (Default Value is 1.65).

important than the weight, a length related variable must be selected first. Based on the value of the first entry, the second entry is constrained within a certain range as displayed in the information area of Figure 51. This range is set at  $\pm 1.65$  standard deviations from the best estimate derived from the first value entered. This range can be redefined by the user as follows:

The first prompting message is "ENTER NEW Z-SCORE" as shown in Figure 47. This Z-score<sup>1</sup> value is used in the equation which calculates the range of permissible values for the second independent variable selected. If the default value of 1.65 is retained, the permissible range will include approximately 90% of all possible values for the second variable. Increasing the Z-score will increase the range and decreasing the Z-score will decrease the range. The value the user types in must fall between -3.0 and +3.0. If the default value of 1.65 is suitable, the user may respond by performing the ALT-CODE/5 sequence. Otherwise, type the new value and enter it by the ALT-CODE/5 sequence.

The next message is "VALUES IN PCTLS? ENTER Y/N" (see Figure 48). If the user's response is "YES" or "Y" or just the ALT-CODE/5 sequence, values will be input by lightpenning percentiles from the column "AVBL PCTL". The sequence is shown in Figures 48, 49, 50, and 51. If the response is "NO" or "N", values for the selected variables will be entered in Engineering units using the alphanumeric keyboard. For values to be input as percentiles, Table 1 shows the sequence of displayed messages and user responses to be followed. If the values are supplied through the alphanumeric keyboard, the

---

<sup>1</sup>Z-score represents the extent to which an individual value falls above or below the mean of a set of data.

VALUES IN PCTLS? ENTER Y/N						
MEMBER 67 USAF ACCEPTED						
INDEPENDENT VARIABLES						
MASS RELATED	UNIT	INPUT	LENGTH RELATED	UNIT	INPUT	AVBL PCTL
WEIGHT	LB		SITTING HEIGHT	IN		1
BIDELT10D BROTH	IN		EYE HGT/SITTING	IN		2
MIP BREADTH/SITT	IN		KNEE HGT/SITTING	IN		3
CHEST DEPTH	IN		BUTTOCK-KNE LGTH	IN		5
			ELBOW-GRIP LGTH	IN		10
			THUMB-TIP REACH	IN		15
						20
						25
						30
						35
						40
						45
						50
						55
						60
						65
						70
						75
						80
						85
						90
						95
						97
						98
						99

Figure 48. INPUT TWO INDEPENDENT VARIABLES Function  
Option to Choose Input Values in Percentile  
or in Engineering Unit.

L.P. FIRST INDEPENDENT VARIABLE

MEMBER 67 USAF ACCEPTED

MASS RELATED		INDEPENDENT VARIABLES		LENGTH RELATED		AVBL	AVBL
	UNIT	INPUT		UNIT	INPUT	UNITS	PCTL
WEIGHT	LB		SITTING HEIGHT	IN		IN	1
BIDELTIOD BRDTH	IN		EYE HGT/SITTING	IN		CM	2
HIP BREADTH/SITT	IN		KNEE HGT/SITTING	IN		MM	3
CHEST DEPTH	IN		BUTTOCK-KNE LGTH	IN		LB	5
			ELBOW-GRIP LGTH	IN		KG	10
			THUMB-TIP REACH	IN			15
							20
							25
							30
							35
							40
							45
							50
							55
							60
							65
							70
							75
							80
							85
							90
							95
							97
							98
							99

Figure 49. INPUT TWO INDEPENDENT VARIABLE Function  
Light-Pen First Independent Variable.

L.P. VARIABLE IN OTHER COLUMN							
MEMBER 67 USAF ACCEPTED							
MASS RELATED	INDEPENDENT VARIABLES		LENGTH RELATED	UNIT	INPUT	AVBL UNITS	AVBL PCTL
	UNIT	INPUT					
WEIGHT.....	LB	95 PCT	SITTING HEIGHT	IN		IN	1
BIDELTIOD BRDTH	IN		EYE HGT/SITTING	IN		CM	2
HIP BREADTH/SITT	IN		KNEE HGT/SITTING	IN		MM	3
CHEST DEPTH	IN		BUTTOCK-KNEE LGTH	IN		LB	5
			ELBOW-GRIP LGTH	IN		KG	10
			THUMB-TIP REACH	IN			15
							20
							25
							30
							35
							40
							45
							50
							55
							60
							65
							70
							75
							80
							85
							90
							95
							97
							98
							99

Figure 50. INPUT TWO INDEPENDENT VARIABLE Function  
 Light-Pen Second Independent Variable.

L.P. PCTL WITHIN RANGE							
SELECT VALUE BETWEEN 25 AND 99 PCT							
INDEPENDENT VARIABLES							
MASS RELATED	UNIT	INPUT	LENGTH RELATED	UNIT	INPUT	AVBL UNITS	AVBL PCTL
WEIGHT	LB	95 PCT	SITTING-HEIGHT	IN		IN	1
BIDELTLOD BRDTH	IN		EYE HGT/SITTING	IN		CM	2
HIP BREADTH/SITT	IN		KNEE HGT/SITTING	IN		MM	3
CHEST DEPTH	IN		BUTTOCK-KNE LGTH	IN		LB	5
			ELBOW-GRIP LGTH	IN		KG	10
			THUMB-TIP REACH	IN			15
							20
							25
							30
							35
							40
							45
							50
							55
							60
							65
							70
							75
							80
							85
							90
							95
							97
							98
							99

Figure 51. INPUT TWO INDEPENDENT VARIABLE Function  
 Light-Pen Percentile for the Second  
 Independent Variable Within Range.

TABLE 1

PROGRAM MESSAGES AND USER RESPONSES FOR PFK13  
WHEN VALUES WILL BE INPUT AS PERCENTILES

(Program Responses Are Listed in Parenthesis)

PROGRAM MESSAGES	USER RESPONSES
L.P. FIRST INDEP. VARIABLE	<p>Light pen a variable from either mass or length column. See Figure 49. (Selected variable will be underlined by program.)</p>
L. P. PERCENTILE	<p>Light pen percentile number from the column "AVBL PCTL". (Selected percentile will be displayed next to underlined variable.)</p>
L.P. VBL IN OTHER COLUMN	<p>Light pen a variable from the column not selected the first time. See Figure 50. (Selected variable will be underlined, if it is in the other column, and a permissible range of percentile values will be displayed in the information area. See Figure 51.)</p>
L.P. PCTL WITHIN RANGE	<p>Light pen a percentile number from the column "AVBL PCTL" which lies within the range of values displayed. See Figure 41. (Selected percentile will be checked and displayed next to underlined variable.)</p>

user should use Table 2 as a guide to the sequence of system messages and user responses. Once the independent values are supplied, the program calculates the surface dimensions required to construct the link system of the man-model. These dimensions are calculated using multiple regression equations from the selected regression member with the user supplied dimensions.

TABLE 2

PROGRAM MESSAGES AND USER RESPONSES FOR PFK13 WHEN  
VALUES WILL BE INPUT AS ABSOLUTE DIMENSIONS

(Program Responses Are Listed in Parenthesis)

PROGRAM MESSAGES	USER RESPONSES
1. VALUES IN PCTLS? ENTER Y/N	Enter "NO" or "N" through the ANKB followed by the ALT-CODE/5 sequence. Y is the default value.
2. DESIRE UNIT CHANGE? ENTER Y/N	If input units are other than inches and pounds, enter "YES" or "Y" through the ANKB followed by the ALT-CODE/5 sequence. "NO" is the default value.
3. L.P. FIRST INDEP. VARIABLE	Light pen a variable from either mass or length column. (Selected variable is underlined.)
4. L.P. NEW UNIT, IF DESIRED (If response to message 2 is "YES".)	If a unit of measurement other than the one listed next to the underlined variable is desired, light pen a new unit from the column "AVBL UNITS". If no change is desired, press ALT-CODE/5 sequence. The system checks that the unit is valid for the type of variable and displays it next to the input value. It also checks for the value to be within range for the selected survey.
5. ENTER NEW VALUE	Type in real number value through the ANKB, followed by the ALT-CODE/5 sequence. (Typed value will be displayed next to underlined variable.)
6. L.P. VBL IN OTHER COLUMN	Light pen a variable from the column not selected the first time. Selected variable will be underlined if it is in the proper column.
7. L.P. NEW UNIT, IF DESIRED (If response to message 2 is "YES".)	Light pen a new unit or depress ALT-CODE/5 sequence for default unit. The system check the unit, computes the range and displays the values in the informational area.
8. ENTER NEW VALUE	Type in real number value within the displayed range, through the ANKB, followed by the ALT-CODE/5 sequence. (Typed value will be verified and displayed next to the underlined variable.)

#### 2.2.14 DISPLAY TABLE Function (PFK14)

The DISPLAY TABLE function provides the user with the opportunity to inspect the table of link dimensions and angles and make changes to any or all of the values, if necessary. Since the table displays internal link lengths, the anthropometry of the man-model should be defined prior to using this function. Figure 52 shows an example of a Display Table.

The user can modify the values in the Display Table by light-penning the value to be changed, typing a new value, and performing ALT-CODE/5 sequence (see Figure 53). When all changes are made the user performs the ALT-CODE/5 sequence to display the new man-model. The transformation angles in this display can be modified to place the man-model in any desired position (see Paragraph 2.2.21).

Other than the choices of slumped or erect posture, and the reposturing in the reach analysis, using the LINK TABLE to change the joint angles is the user's most important method to change the body position of the man-model. To properly use this table refer to Table 3 for all link definitions.

As described in Section 1, the link system is a series of vectors added together. Each link vector has a local coordinate system with its origin at the distal end. The orientation of the next link is defined in this local coordinate system. The Phi, Theta, and Psi correspond to Euler angles as shown in Figure 54. Since these local coordinate systems are usually not aligned with the base system which has its origin at SRP, no rule can be given for selecting a particular direction of movement. The user should try angular changes one-by-one to obtain desired results.

Any change made in link length is reflected in the man-model for all postures. However, changes made in angles are reflected only in PROGRAMMED Posture.

L.P. VALUE TO CHANGE

--LINK--	LENGTH	-PHI-	-THETA-	-PSI-
SRP	0.0	0.0	0.0	0.0
SRP-MHIP	5.86	0.0	53.7	0.0
STOMACH	5.41	0.0	-74.2	0.0
CHEST	7.83	0.0	4.8	0.0
LWR NECK	7.77	0.0	10.0	0.0
UPR NECK	5.42	0.0	20.0	0.0
MID HEAD	1.46	0.0	-14.3	0.0
MH-MEYE	3.46	0.0	90.0	0.0
MEYE-REY	1.25	-90.0	90.0	0.0
MEYE-LEY	1.25	90.0	90.0	0.0
LN-MIDSS	3.34	0.0	115.0	0.0
MSS-RSS	1.00	-90.0	90.0	29.3
RSS-RSLD	8.57	22.0	31.7	0.0
RSLDR	0.0	0.0	-31.7	-112.0
RUPARM	11.19	0.0	-90.0	-90.0
RLWRM	10.80	0.0	90.0	0.0
RGRIPCTR	2.04	0.0	0.0	0.0
RFRCH	4.79	0.0	0.0	0.0
RFNGRTIP	7.68	0.0	0.0	0.0
MSS-LSS	1.00	90.0	90.0	-29.3
LSS-LSLD	8.57	-22.0	31.7	0.0
LSLDR	0.0	0.0	-31.7	112.0
LUPARM	11.19	0.0	-90.0	90.0
LLWRM	10.80	0.0	90.0	0.0
LGRIPCTR	2.04	0.0	0.0	0.0
LFRCH	4.79	0.0	0.0	0.0
LFNGRTIP	7.68	0.0	0.0	0.0
MHIP-RMP	3.64	-90.0	90.0	53.7
RUPRLEG	17.34	97.0	90.0	-90.0
RLWRLEG	16.55	0.0	60.0	0.0
RMK-RRCM	2.25	0.0	0.0	0.0
MHIP-LMP	3.64	90.0	90.0	-53.7
LUPRLEG	17.34	-97.0	90.0	90.0
LLWRLEG	16.55	0.0	60.0	0.0
LNK-LRCM	2.25	0.0	0.0	0.0

Figure 52. DISPLAY TABLE Displays Links, Their Lengths and Euler Angles.

ENTER NEW VALUE  
110\_

--LINK--	LENGTH	-PHI-	-THETA-	-PSI-
SRP	0.0	0.0	0.0	0.0
SRP-MHIP	5.86	0.0	53.7	0.0
STOMACH	5.41	0.0	-74.2	0.0
CHEST	9.83	0.0	4.8	0.0
LWR NECK	7.77	0.0	10.0	0.0
UPR NECK	5.42	0.0	20.0	0.0
MID HEAD	1.46	0.0	-14.3	0.0
MH-MEYE	3.46	0.0	-30.0	0.0
MEYE-REY	1.25	-90.0	90.0	0.0
MEYE-LEY	1.25	90.0	90.0	0.0
LN-MIDSS	3.34	0.0	115.0	0.0
MSS-RSS	1.00	-90.0	90.0	29.3
RSS-RSLD	8.57	22.0	31.9	0.0
RSLDR	0.0	0.0	-31.9	-112.0
RUPARM	11.19	0.0	-90.0	-90.0
RLWRM	10.80	0.0	90.0	0.0
RGRIPICTR	2.04	0.0	0.0	0.0
RFRCH	4.79	0.0	0.0	0.0
RFNGRTIP	7.68	0.0	0.0	0.0
MSS-LSS	1.00	90.0	90.0	-29.3
LSS-LSLD	8.57	-22.0	31.9	0.0
LSLDR	0.0	0.0	-31.9	112.0
LUPARM	11.19	0.0	-90.0	90.0
LLWRM	10.80	0.0	90.0	0.0
LGRIPCTR	2.04	0.0	0.0	0.0
LFRCH	4.79	0.0	0.0	0.0
LFNGRTIP	7.68	0.0	0.0	0.0
MHIP-RHP	3.46	-90.0	90.0	53.7
RUPLEG	17.34	91.0	90.0	-90.0
RLVRLEG	16.55	0.0	60.0	0.0
RNK-RRCH	2.25	0.0	0.0	0.0
MHIP-LHP	3.46	90.0	90.0	-53.7
LUPLEG	17.34	-91.0	90.0	90.0
LLVRLEG	16.55	0.0	60.0	0.0
LNK-LRCH	2.25	0.0	0.0	0.0

Figure 53. DISPLAY TABLE Change THETA Value of MH-MEYE from 90° to 110°.

TABLE 3  
LINK SYSTEM DEFINITION

<u>LINK NO.</u>	<u>NAME</u>	<u>DEFINITION</u>
0	SRP	Zero-length link at the SRP
1	SRP-MHIP	SRP to mid-hip
2	STOMACH	Mid-hip to L3/L4 disc
3	CHEST	L3/L4 disc to T8/T9 disc
4	LWR NECK	T8/T9 disc to T1 vertebra
5	UPR NECK	T1 vertebra to atlas
6	MID HEAD	Atlas to mid-head point
7	MH-MEYE	Mid-head point to mid-eye point
8	MEYE-REY	Mid-eye point to right eye
9	MEYE-LEY	Mid-eye point to left eye
10	LN-MIDSS	T1 vertebra to mid-suprasternale
11	MSS-RSS	Mid-suprasternale to right suprasternale
12	RSS-RSLD	Right suprasternale to right shoulder
13	RSLDR	Zero-length link at the right shoulder
14	RUPARM	Right shoulder to right elbow
15	RLWARM	Right elbow to right wrist
16	RGRIPCTR	Right wrist to grip center point
17	RFRCH	Right grip center point to functional reach point
18	RFNGRTIP	Right functional reach point to fingertip reach point
19	MSS-LSS	Mid-suprasternale to left suprasternale
20	LSS-LSLD	Left suprasternale to left shoulder
21	LSLDR	Zero-length link at the left shoulder
22	LUPARM	Left shoulder to left elbow
23	LLWRARM	Left elbow to left wrist
24	LGRIPCTR	Left wrist to grip center point
25	LFRCH	Left grip center point to functional reach point
26	LFNGRTIP	Left functional reach point to fingertip reach point
27	MHIP-RHP	Mid-hip to right hip
28	RUPRLEG	Right hip to right knee
29	RLWRLEG	Right knee to right ankle
30	RNK-RRCH	Right ankle to bottom of the right foot
31	MHIP-LHP	Mid-hip to left hip
32	LUPRLEG	Left hip to left knee
33	LLWRLEG	Left knee to left ankle
34	LNK-LRCH	Left ankle to bottom of left foot

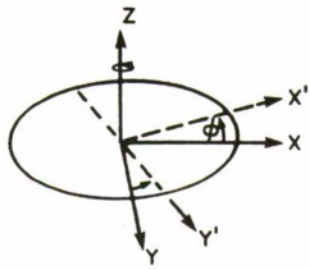

1st ROTATION ABOUT THE Z AXIS  
 DEFINES THE JOINT ROTATION  
 AXIS. FOR ELBOW,  $\phi = 0^\circ$   
 BECAUSE THIS ANGLE WAS  
 ESTABLISHED BY  $\psi$  FROM  
 THE PREVIOUS SYSTEM. (THE  
 ELBOW IS ROTATED BY THE  
 UPPER ARM).

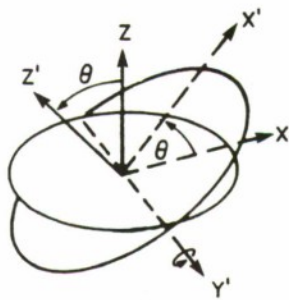
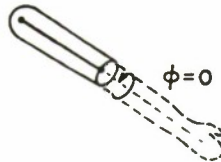

2nd ROTATION ABOUT THE NEWLY FORMED  
Y' AXIS. FOR THE ELBOW,  
 THIS ANGLE  $\theta$  IS THE DEVIATION  
 FROM A STRAIGHT ANGLE.

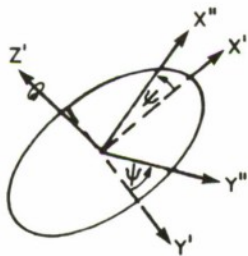
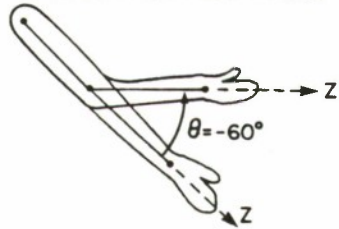

3rd ROTATION ABOUT THE Z' AXIS  
 REPRESENTS THE ROTATION OF  
 THE DISTAL END OF LINK, OR  
 IN THE CASE OF THE ELBOW  
 SYSTEM, IT IS THE ROTATION  
 OF THE FOREARM.

RIGHT ARM

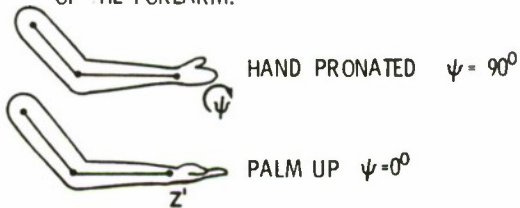

Figure 54. Example of Euler Angle Changes for Elbow Joints.

### 2.2.15 DUMP CRT Function (PFK15)

The DUMP CRT function plots the display on the 2250 screen to the Gould Plotter. This plot includes the prompting area, the information area, and the COMBIMAN display area. A sample plot of the DUMP CRT function is shown in Figure 55. However, to get a CRT Dump, the Region parameter on STEPl in Figure 61 has to be changed from 550K to 600K or higher depending on the plotter and the size of the crew station. This plot is different from the on-line plot described in Paragraph 2.2.9 because there is no choice of scale or perspective views and it is a 10" x 10" hard copy plot of the 12" x 12" CRT display. The DUMP CRT function is available to the user at all times like the ALT-CODE/0 cancel option.

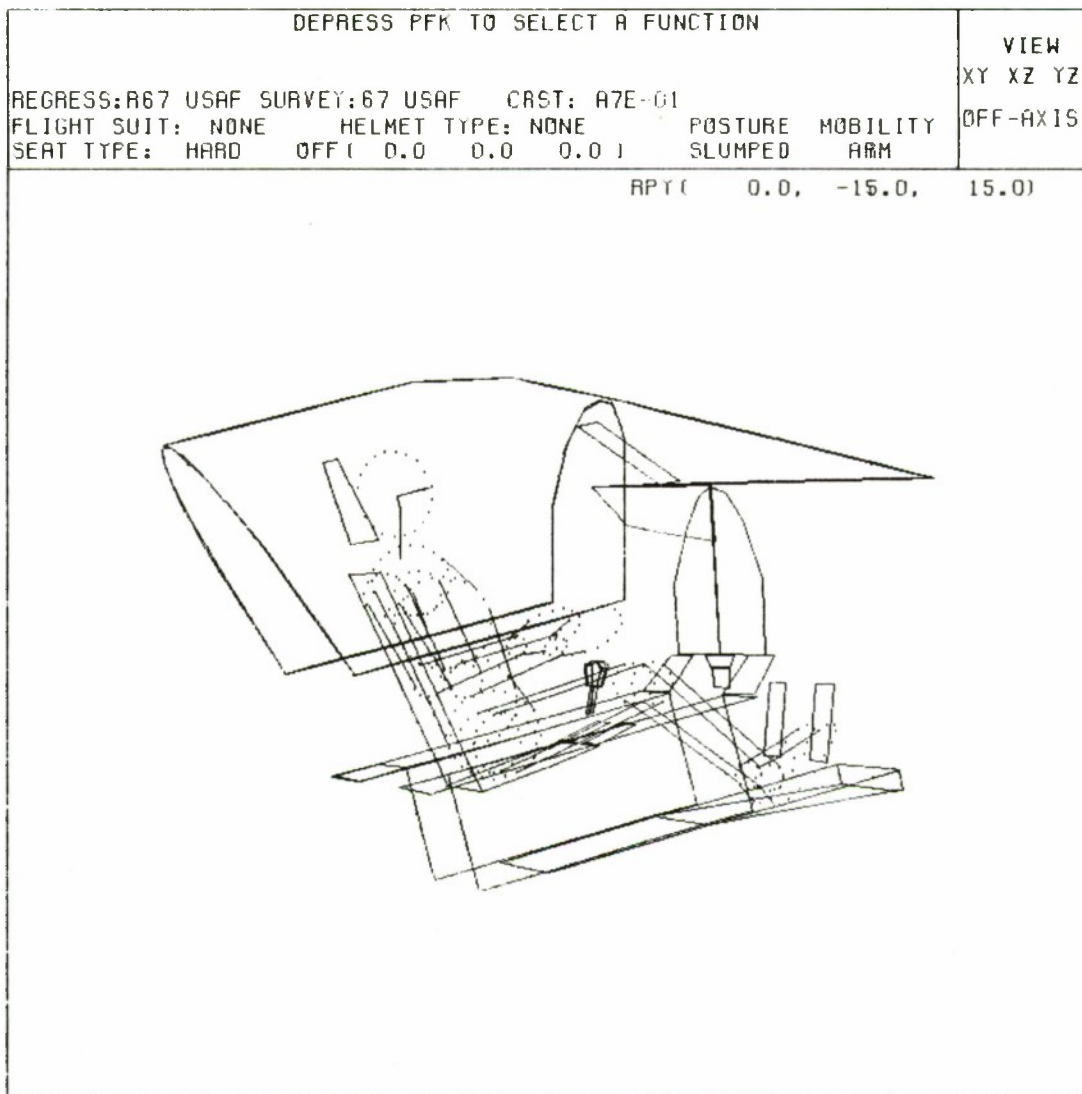

Figure 55. DUMP CRT Function. 2250 Screen Display Plotted on the On-Line GOULD Plotter.

## 2.2.16 DESIGN PANEL Function (PFK16)

The DESIGN PANEL function allows the user to add a panel to an existing crew station, or design a new crew station by assembling a series of new panels.

In response to prompting message "ENTER PANEL NAME" the user must type a panel name of up to eight characters and enter it by performing ALT-CODE/5 sequence. To the prompting message "ENTER PANEL TYPE" the user should enter a type number "1" for general crew station, "2" for seat panel, and "3" for rudder or brake pedal through the ANKB followed by ALT-CODE/5 sequence. Finally as a response to the message "ENTER NUMBER OF VERTICES" the user must supply the number of vertices for the new panel. The number of vertices must be 3, 4, 5, or 6. Then with the cross symbol "+" and the lighted PFKs (see Figure 33), the user defines the vertices of the panel, one at a time, in the X-Z plane and then in the Y-Z plane using the method described in Paragraph 2.2.11.1\*.

As mentioned in Paragraph 2.2.11, PFK12 is used to stop the "+" while in motion. When PFK12 is depressed twice consecutively, the location of the vertex is defined in the displayed view. When subsequent vertices are defined, they are automatically connected by lines.

The panel thus defined can be treated like any other panel. It will not, however, be automatically added to the permanent Crew Station Data Base.

The newly designed panel name and coordinates will appear on the printout as shown in Figure 56.

The panel will be erased when the "ERASE" option of the RETRIEVE CREW STATION function is selected again.

---

\*The program assigns the lowest unused sequence number as the "internal reference number" for this new panel.

CBM0011 COMBIMAN V5, DATE= 5/ 1/61, TIME= 9. 1.21.  
 CBM0331 REGRESSION VALUES FROM MEMBER K67 USAF.  
 CBM0151 SURVEY DATA FROM 67 USAF  
 CBM0451 USER CHOOSES TO INPUT 2 INDEPENDENT VARIABLES  
 CBM0411 INPUT VARIABLES WILL BE IN PERCENTILES.  
 SITTING HEIGHT 50 PCT 36.650 IN  
 WEIGHT 50 PCT 172.420 LB

-----COMPUTER CALC. DEP. VALUES-----  
 NO. VEL. NAME VALUE UNIT  
 -----  
 1 WEIGHT 172.420 LB  
 2 SITTING HEIGHT 36.650 IN  
 3 ACROMION HGT/SIT 24.012 IN  
 4 KNEE HGT/SITTING 21.940 IN  
 5 BUTTCK-KNE LGTH 23.771 IN  
 6 SHOULDR-ELB LGTH 14.143 IN  
 7 BIACROMIAL BRDTH 16.015 IN  
 8 HIP BREADTH 13.851 IN  
 9 CHEST DEPTH 9.625 IN  
 10 FOOT LENGTH 10.631 IN  
 11 HAND LENGTH 7.520 IN  
 12 ELBOW-WRIST LGTH 11.802 IN

CBM0091 SWITCH 20 ON  
 CBM0521 VISIBILITY PLOT GENERATED FOR A7E-C1  
 CBM0141 C/S DATA FROM A7--SEAT  
 CBM0141 C/S DATA FROM A7E-C1

CBM0071	87.) NEWPNL , TYPE= 1, 4 VERTICES
CBM0071	23.50 C.0 21.00 23.50 0.0 17.80 27.50 0.0 16.40 27.50 0.0 19.20

CBM0091 SWITCH 6 ON  
 CBM0051 SWITCH 72 ON  
 CBM0331 REGRESSION VALUES FROM MEMBER K67 USAF.  
 CBM0151 SURVEY DATA FROM 67 USAF  
 CBM0451 USER CHOOSES TO INPUT 2 INDEPENDENT VARIABLES  
 CBM0411 INPUT VARIABLES WILL BE IN PERCENTILES.  
 SITTING HEIGHT 50 PCT 36.650 IN  
 WEIGHT 50 PCT 172.420 LB

-----COMPUTER CALC. DEP. VALUES-----  
 NO. VEL. NAME VALUE UNIT  
 -----  
 1 WEIGHT 172.420 LB  
 2 SITTING HEIGHT 36.650 IN  
 3 ACROMION HGT/SIT 24.012 IN  
 4 KNEE HGT/SITTING 21.940 IN  
 5 BUTTCK-KNE LGTH 23.771 IN  
 6 SHOULDR-ELB LGTH 14.143 IN  
 7 BIACROMIAL BRDTH 16.015 IN  
 8 HIP BREADTH 13.851 IN  
 9 CHEST DEPTH 9.625 IN  
 10 FOOT LENGTH 10.631 IN  
 11 HAND LENGTH 7.520 IN  
 12 ELBOW-WRIST LGTH 11.802 IN

CBM0021 PROGRAM END.

Figure 56. Printed Output of the Newly Designed Panel NEWPNL is Within the Box.

### 2.2.17 DELETE PANEL Function (PFk18)

The DELETE PANEL function allows the user to remove a crew station panel from the display. It does not remove the panel from the Crew Station Data Base. Once deleted, the panel cannot be recalled using the INCLUDE OBJECT function. It must be either recreated by the DESIGN PANEL function, or the entire crew station must be recalled again using the RETRIEVE CREW STATION function in Paragraph 2.2.6. In both cases, the crew station will be reset to its original configuration.

To delete a panel, the name of the panel must be entered through the ANKB as response to prompting message "ENTER PANEL NAME". If the specified panel does not exist, the program repeats the prompt until the user specifies an existing panel, or performs ALT-CODE/5 sequence. If no name is specified by signaling only ALT-CODE/5 sequence, the function request is ignored and no deletion occurs. The panel name can be found with the IDENTIFY OBJECT function described in Paragraph 2.2.2.

The DELETE PANEL function is different from the OMIT OBJECT function because this function deletes the panel from the display and cannot be redisplayed by invoking the INCLUDE OBJECT function.

## 2.2.18 CHANGE PERSPECTIVE Function (PFK22)

The CHANGE PERSPECTIVE function allows the user to change the point of view and/or the effective viewing distance between the displayed man-model and the crew station. This function is useful in enhancing the perspective and therefore the three dimensional character of the displayed image.

To activate the CHANGE PERSPECTIVE function, first depress PFK22. The program displays the message "VIEW ADJUST" and temporarily redefines PFKs 1, 2, 3, 4, 5, 6, 9, and 10 as shown in Figure 57. If the user depresses PFK9, the message "L.P. NEW CENTER POINT" is displayed. The user may respond by light-penning any desired point in the display. Now the program displays the man-model and the crew station as if looking along the point light-penned. The perspective of the display is initialized as if the viewing distance is 30 feet away from the screen. This distance may be increased in increments of 10 feet by repeatedly depressing PFK1, or decreased (closer to the screen) in increments of 10 feet by depressing PFK3. This distance increment may be redefined by selecting PFK4, for a 1 foot increment; PFK5, for a 10 feet increment; or PFK6, for a 100 feet increment. However, the lower and upper limits for the effective viewing distance are 10 feet and 1,000 feet respectively.

PFK9 must be depressed to select another view point.

PFK2 must be depressed to terminate the CHANGE PERSPECTIVE function and to return to the main program, resetting all PFKs to the original definition.

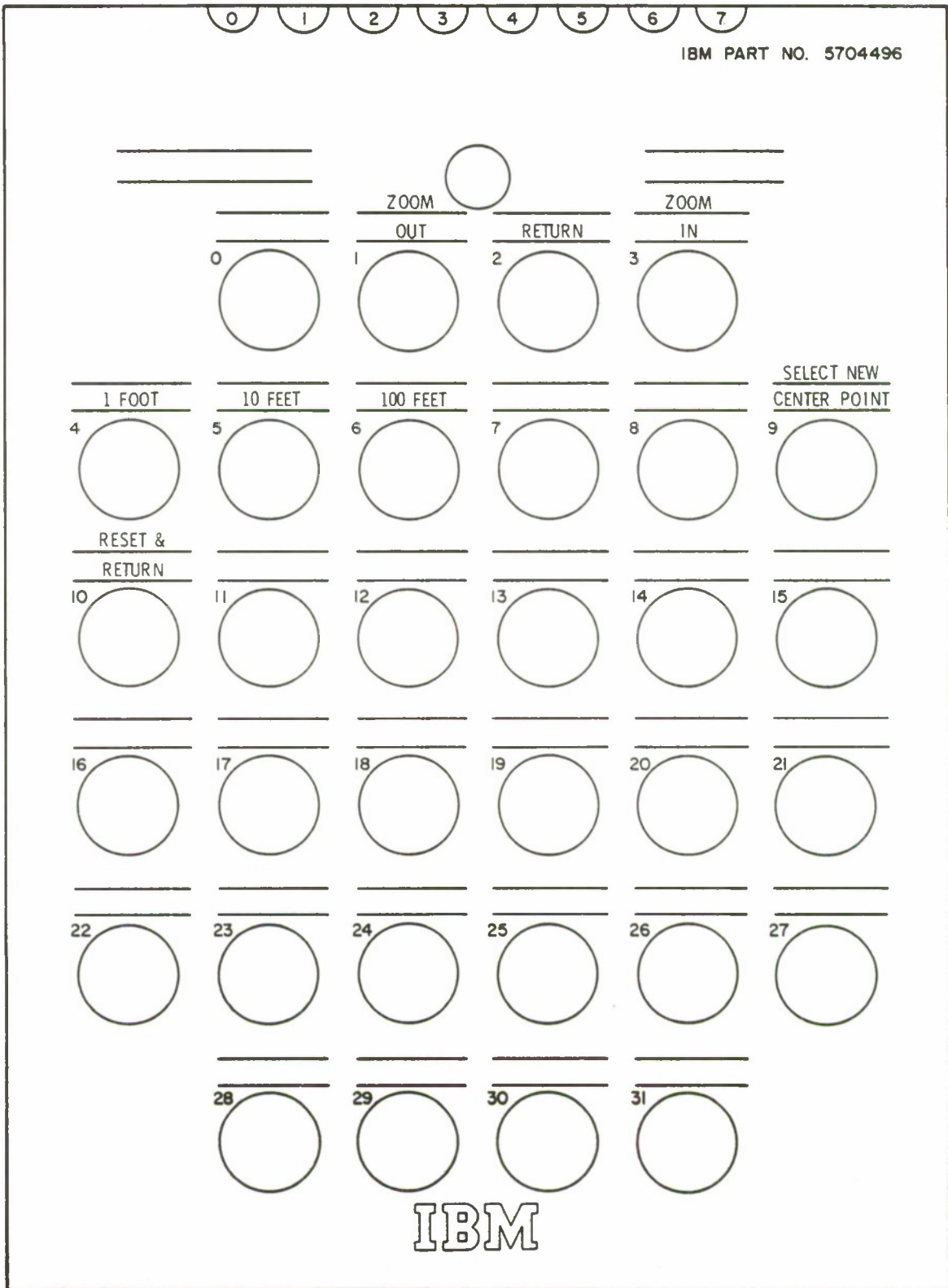

Figure 57. PFK's for Change Perspective Function.

PFK10 terminates the CHANGE PERSPECTIVE function, resetting the display and PFK definitions to their original positions.

Example: To view the display with respect to the left eye of the man-model, first depress PFK22. Then the PFKs 1, 2, 3, 4, 5, 6, 9, and 10 light up and the message "VIEW ADJUST" is displayed along with the man-model and crew station. Depress PFK9 and respond to the prompting message on the screen "L.P. NEW CENTER POINT" by light-penning the left eye of the man-model. The new display will be along a line with the same horizontal and vertical coordinates as the left eye of the man-model.

#### 2.2.19 RESET SLUMPED POSTURE Function (PFK23)

The RESET SLUMPED POSTURE function resets the transformation angles of the man-model so that it assumes a slumped posture, as shown in Figure 58. The "slumped posture" is a posture for sitting erect in a seat with 13 degree back angle and a 6 degree seat pan angle. If other postures are desired, the skeletal-link angles have to be changed by the method specified in Paragraph 2.2.14, the DISPLAY TABLE function and the RESET PROGRAMMED POSTURE function as described in Paragraph 2.2.21. This function is commonly used to get back to a starting posture after a reach analysis or a modification of joint angles as described in Paragraph 2.2.14. The SLUMPED POSTURE is also the default posture of the man-model.

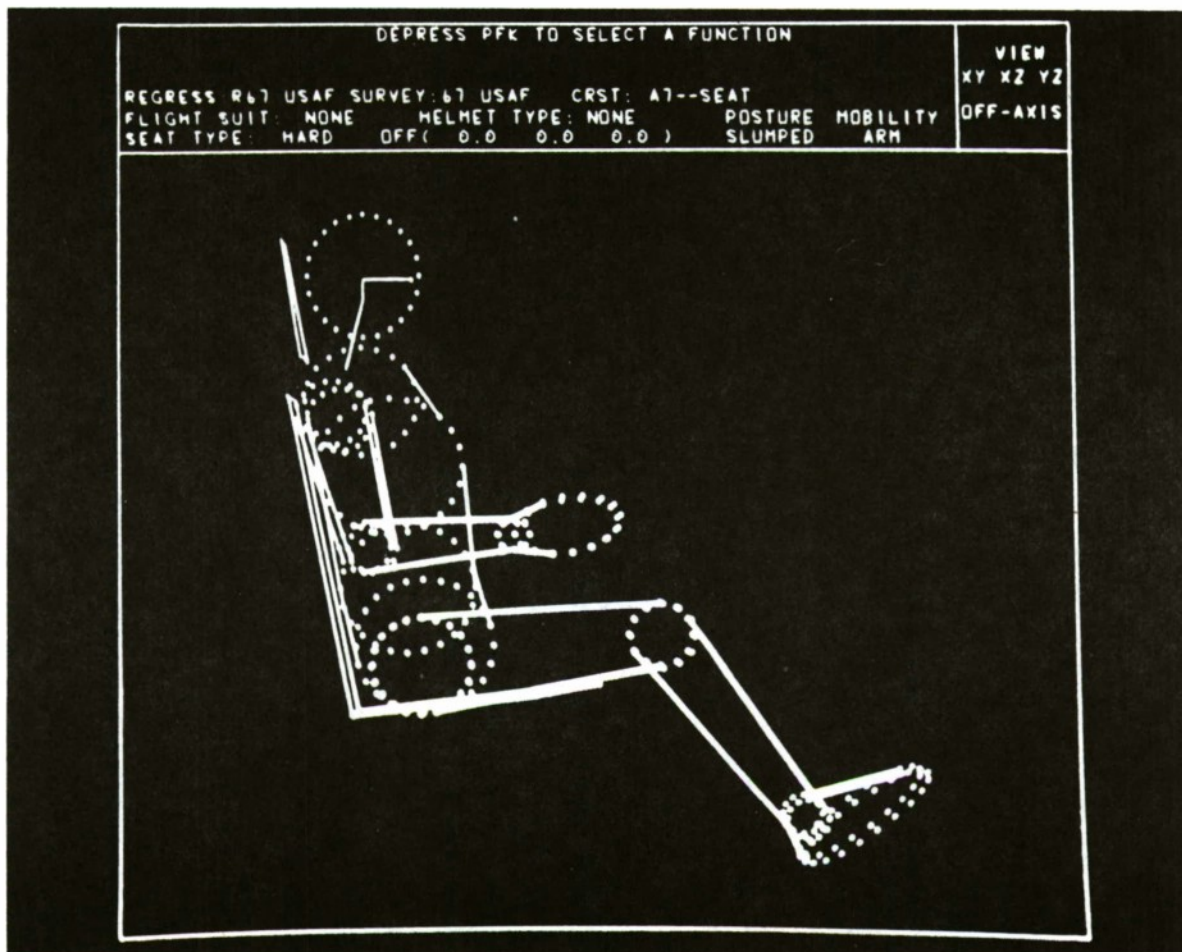

Figure 58. RESET SLUMPED Posture Function.

### 2.2.20 RESET ERECT POSTURE Function (PFK24)

The RESET ERECT POSTURE function resets the transformation angles of the man-model so that it assumes the standard erect posture as shown in Figure 59.

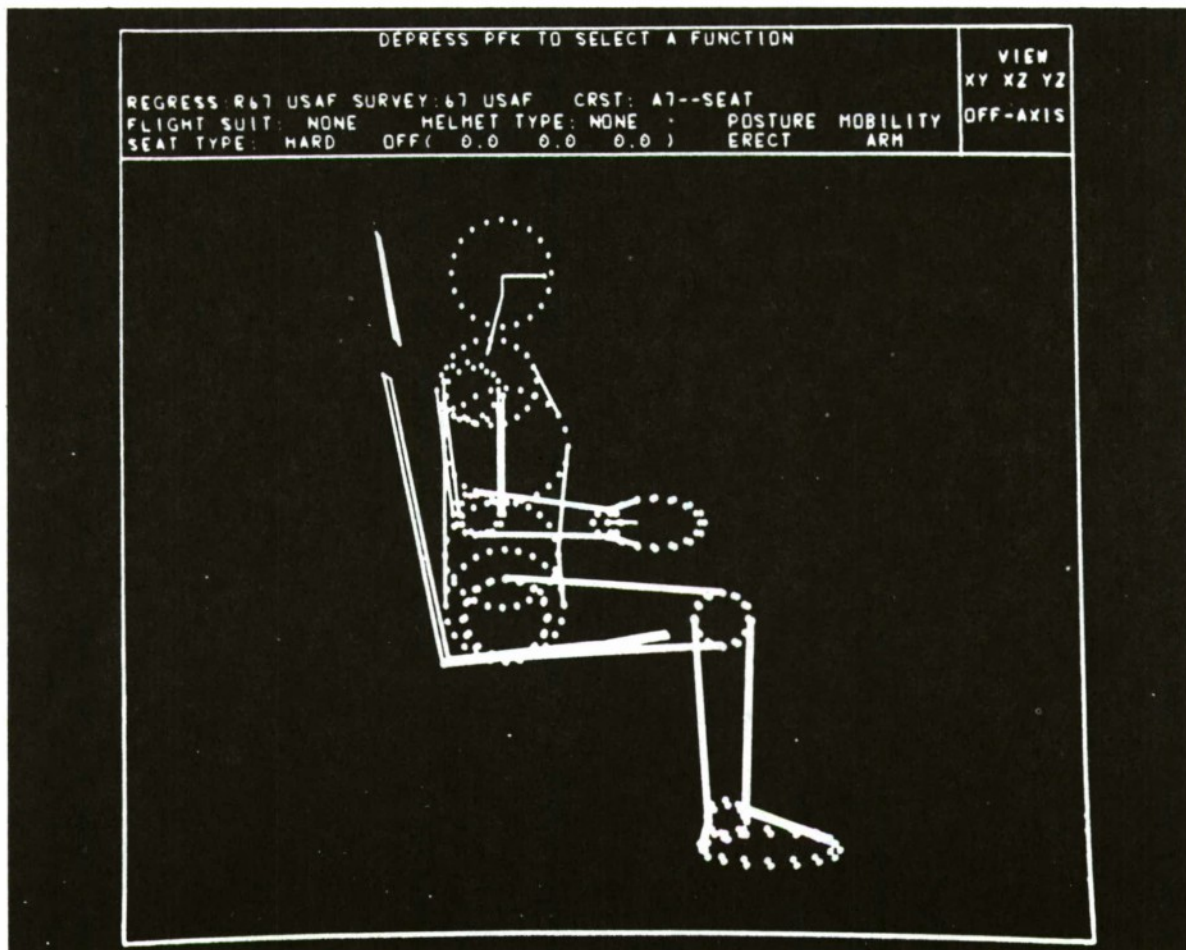

Figure 59. RESET ERECT POSTURE Function.

### 2.2.21 RESET PROGRAMMED POSTURE Function (PFK25)

The RESET PROGRAMMED POSTURE function resets the transformation angles of the man-model so that it assumes the "Programmed Posture". The "Programmed Posture" is any posture the user desires, which can be achieved by modifying the transformation angles using the DISPLAY TABLE function (see Paragraph 2.2.14). After all changes are made, the new posture of the man-model can be redisplayed at any time by depressing PFK25 (see Figure 60).

When the program CBM05 is initialized, the angles for the SLUMPED POSTURE are automatically entered into this PROGRAMMED POSTURE storage area, so initially pressing the PFK25 merely recalls the SLUMPED POSTURE. However, anytime the user changes any one or more angles in the link system Display Table, the changed angles are automatically entered into the PROGRAMMED POSTURE storage area. This function may be thought of as a "redisplay" of the last change to the Display Table (see Paragraph 2.2.14).

The angles changed by this function are not stored permanently. Therefore, everytime a new man-model is defined the angles for PROGRAMMED POSTURE must be redefined.

This function may be used to define a working posture to the user's own specification. Normally, a pilot sits with upper-back and head well forward, causing the eye position to be lowered. Since one posture will not serve all applications, this function allows the user to define and recall any posture.

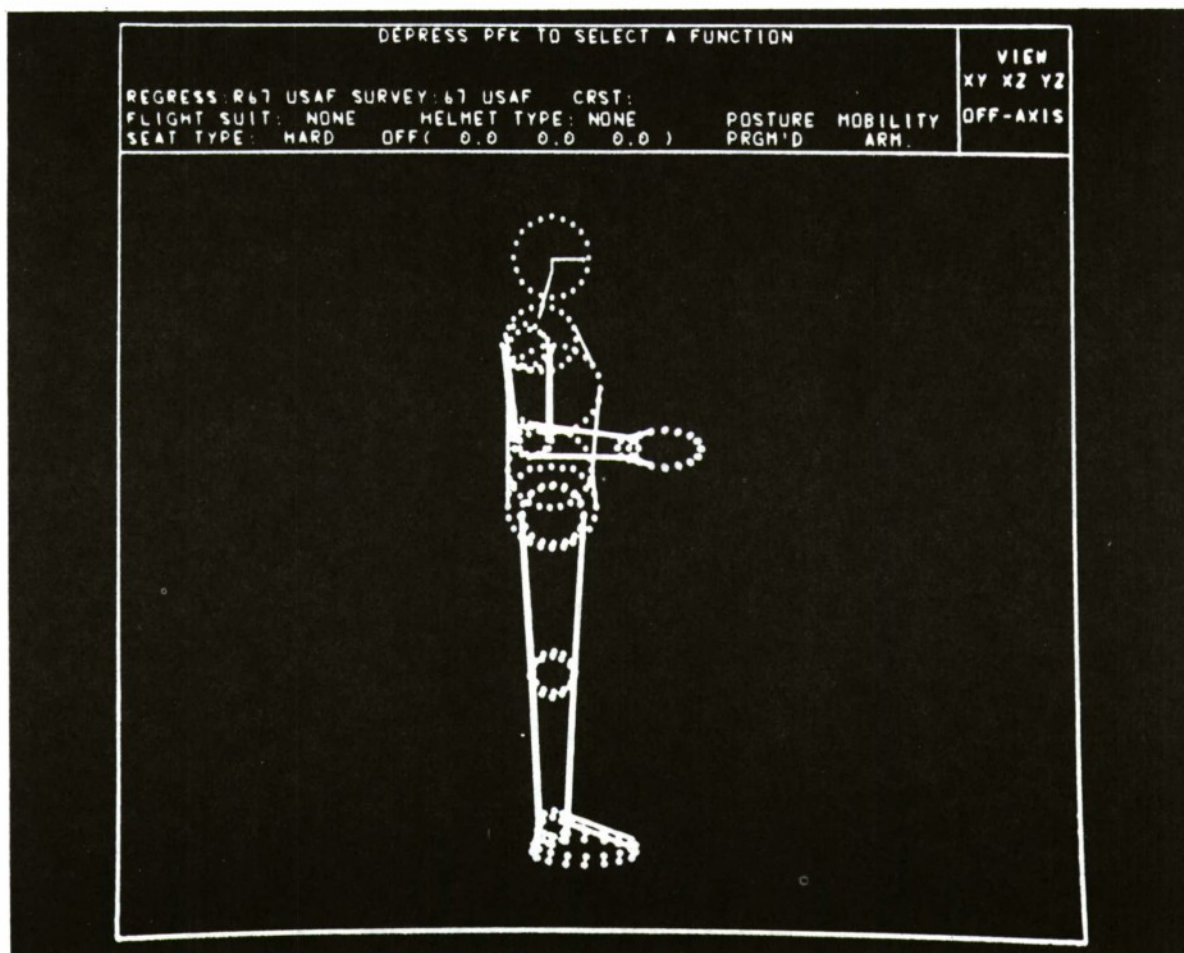

Figure 60. RESET PROGRAMMED POSTURE Function.

## 2.2.22 INCREMENT ROLL, PITCH, AND YAW ANGLE Function (PFK26)

The INCREMENT ROLL, PITCH AND YAW ANGLE function allows the user to enter a set of roll, pitch and yaw angle increments by which the man-model and crew station are rotated; and a maximum number of iterations desired before the display resets to roll, pitch and yaw angle values of 0.0 degrees. It is similar to a series of "CHANGE VIEW" function calls described in Paragraph 2.2.1.

This feature allows the user to rapidly rotate the model through a series of discrete steps without taking the time to enter new roll, pitch, and yaw angles using the CHANGE VIEW function. In the default case built into the program, the display assumes a side view with the first selection of PFK26 and on each depression of PFK26 the displayed image rotates -15 degrees in pitch (nose up) and +15 degrees in yaw (left) for six discrete steps, ending with a top view of the displayed crew station. The next depression of PFK26 resets the display to the original side view. The user may pause after any step to make a plot, or select other functions.

The preprogrammed example uses six discrete rotational increments of 0 degrees, -15 degrees, and, +15 degrees for the roll, pitch, and yaw angles. The user may redefine the number of increments or the roll, pitch, and yaw increments in the following manner.

First set State Switch 10 "ON" as described in Paragraph 2.2.24. Then depress PFK26 and respond to message "ENTER ROLL ANGLE" by entering the ROLL increment angle in degrees through the ANKB. Respond to subsequent messages to enter PITCH and YAW angles the same way. The message "ENTER MAX. NO. ITERATIONS" then appears in the Prompting Area of the

CRT. The user must then type the number of steps the program should take to reset the man-model from the ANKB followed by ALT-CODE/5 sequence. If the user wishes to change the Roll, Pitch, and Yaw angles or the number of iterations again, the State Switch 10 must once again be set "ON" and PFK26 depressed as above.

### 2.2.23 SEAT ADJUST Function (PFK27)

The SEAT ADJUST function allows the user to offset the man-model and his seat, if any, with respect to the displayed crew station. This function cannot be activated unless a crew station is displayed on the CRT screen. A seat may or may not be preset at the user's option. The default values of the coordinates for this function are X=0, Y=0, and Z=0. After depressing PFK27, the user is prompted to enter the X coordinate off-set. The value in inches is typed using the ANKB and is entered by performing the ALT-CODE/5 sequence as shown in Figure 61. If the default value (0 inch) is to be retained, simply perform the ALT-CODE/5 sequence. The program then prompts the user to enter the Y and Z-coordinates in that order. The user must enter them the same way the X-coordinate is entered. The new coordinates will be displayed in the Information Area. Since the seat may be "adjusted" in three dimensions, this provides a method for placing the man-model (and seat) in different stations in a multi-operator crew station.



Figure 61. SEAT ADJUST Function Enter X Coordinate Offset in Inches.

#### 2.2.24 ZOOM Function (PFK28)

The ZOOM function allows the user to "Zoom-in" on a user defined portion of the COMBIMAN Display Area. To activate the ZOOM function depress PFK28. The message "DEFINE ZOOM WINDOW" momentarily appears in the Prompting Area of the CRT. Next, a matrix of dots at 0.5 inch intervals cover the COMBIMAN Display Area and a message "L.P. LOWER LEFT CORNER" appear in the Prompting Area of the CRT as shown in Figure 62.

To cancel the ZOOM function at this point, simply perform the ALT-CODE/5 sequence and the program returns to the main routine. Otherwise light pen a dot to designate the lower left hand corner of the proposed zoom window. Now the program displays the limiting left and bottom lines of the window, and erases all dots below the horizontal line and left of the vertical line. Also the message "L.P. UPPPER RIGHT CORNER" appears in the Prompting Area of the screen as shown in Figure 63. The user may enter the ALT-CODE/5 sequence to register the upper right corner of the Display Area as the upper right corner of the zoom window or may light pen a dot to define the upper right corner of the zoom window. Now all the dots are removed and the completed zoom window boundaries are displayed as shown in Figure 64. The display is then regenerated with the information within the defined zoom window filling the entire Display Area of the CRT as shown in Figure 65.

The message "END ZOOM? ENTER Y/N" then appears in the Prompting Area of the CRT. The user now has the option to zoom-in further on the current display by answering "N" or "NO" using the ANKB, or to end the ZOOM function by depressing the ALT-CODE/5 sequence. Note that "Y" or "YES" is the default for the "END ZOOM? ENTER Y/N" message. When the ZOOM function is ended, control returns to the main routine, however, the

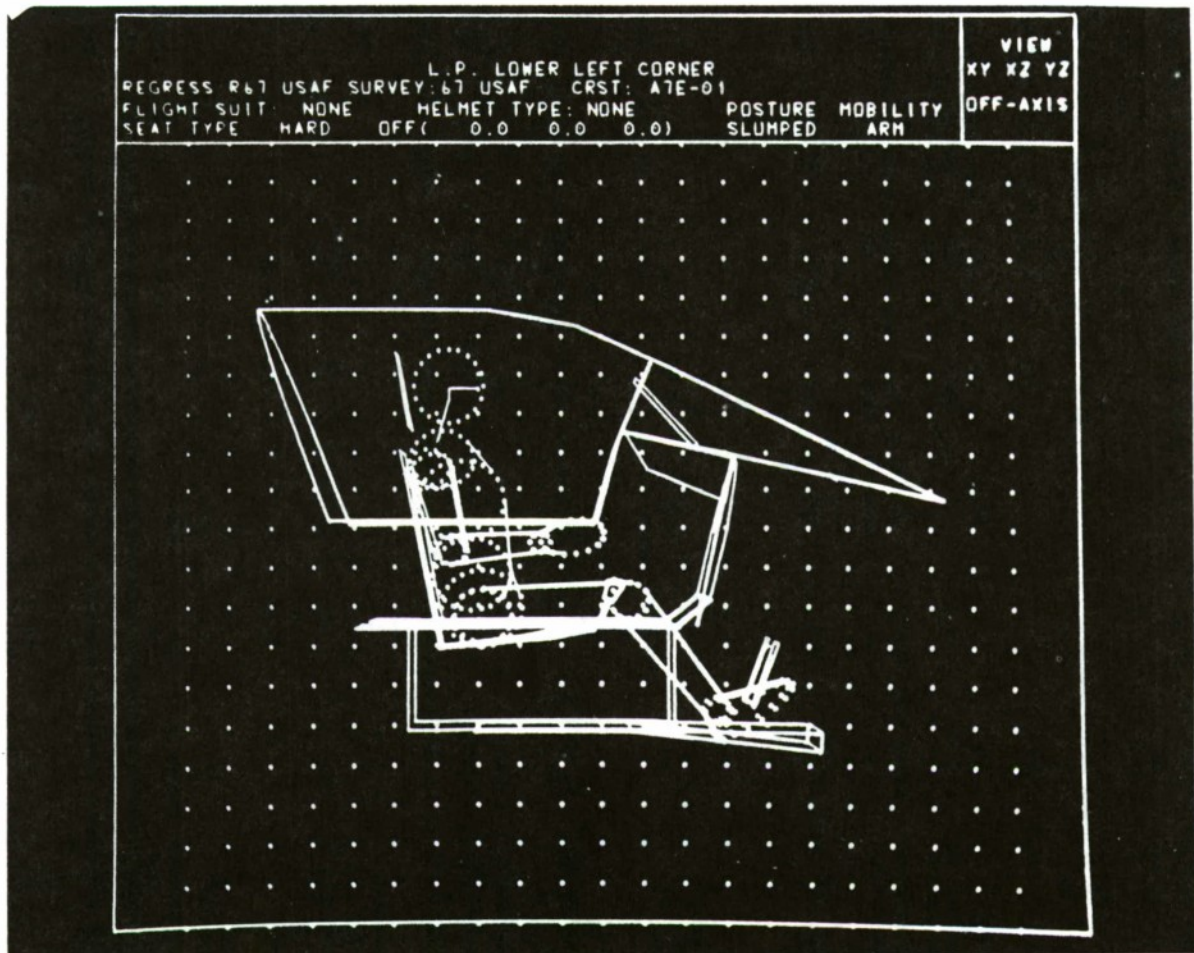

Figure 62. Define ZOOM Window. Step 1 - Light Pen Lower Left-Hand Corner of the ZOOM Window.

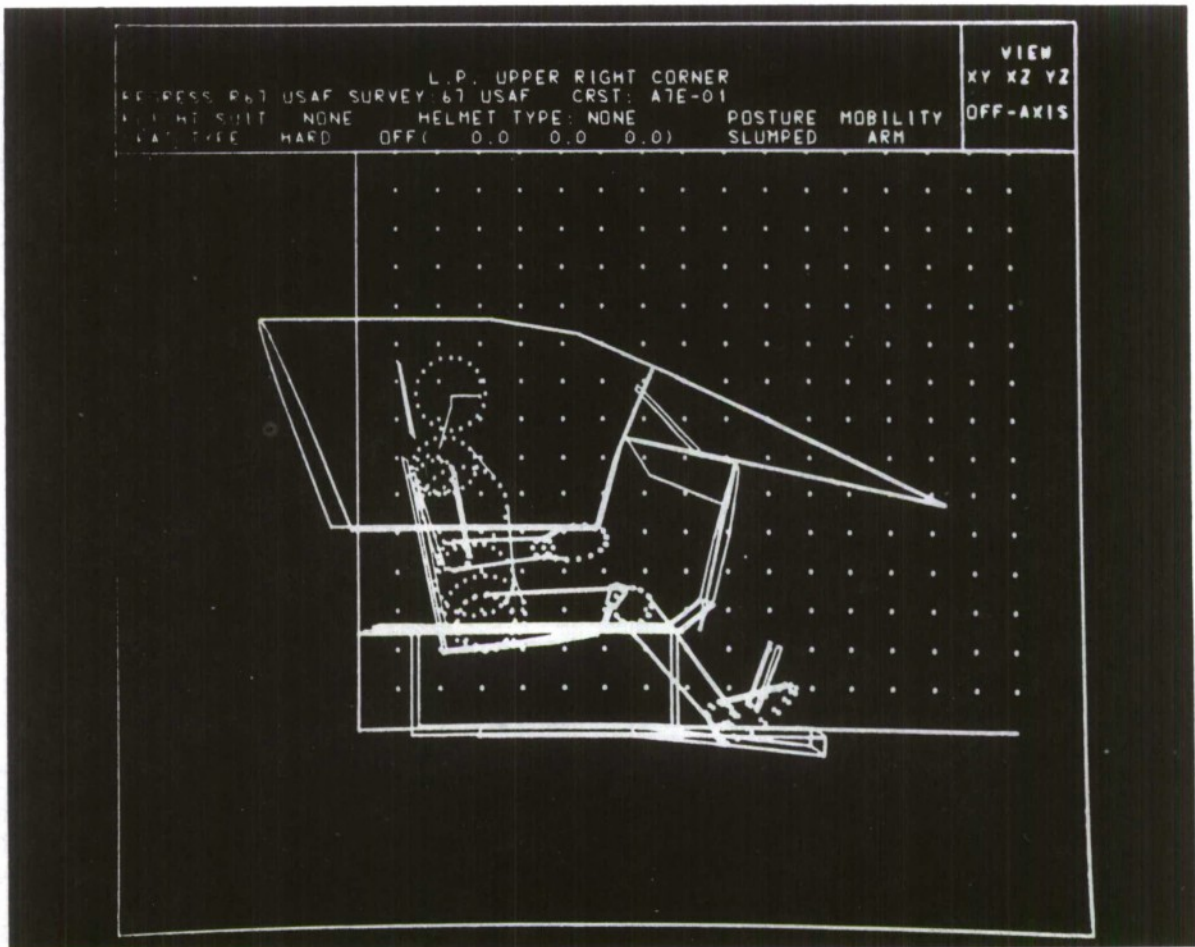

Figure 63. Define ZOOM Window. Step 2 - Light Pen Upper Right Corner of ZOOM Window.

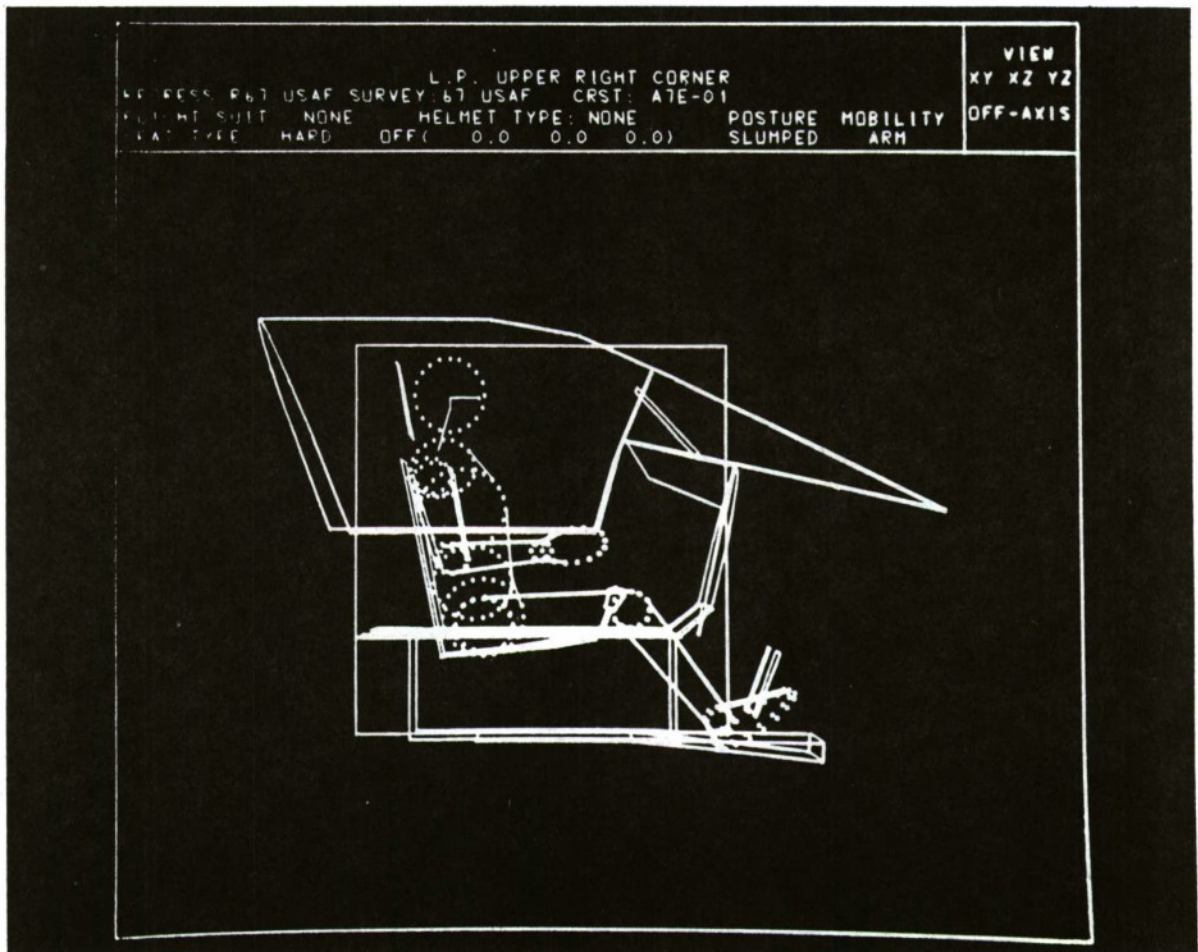

Figure 64. The Fully Defined ZOOM Window.

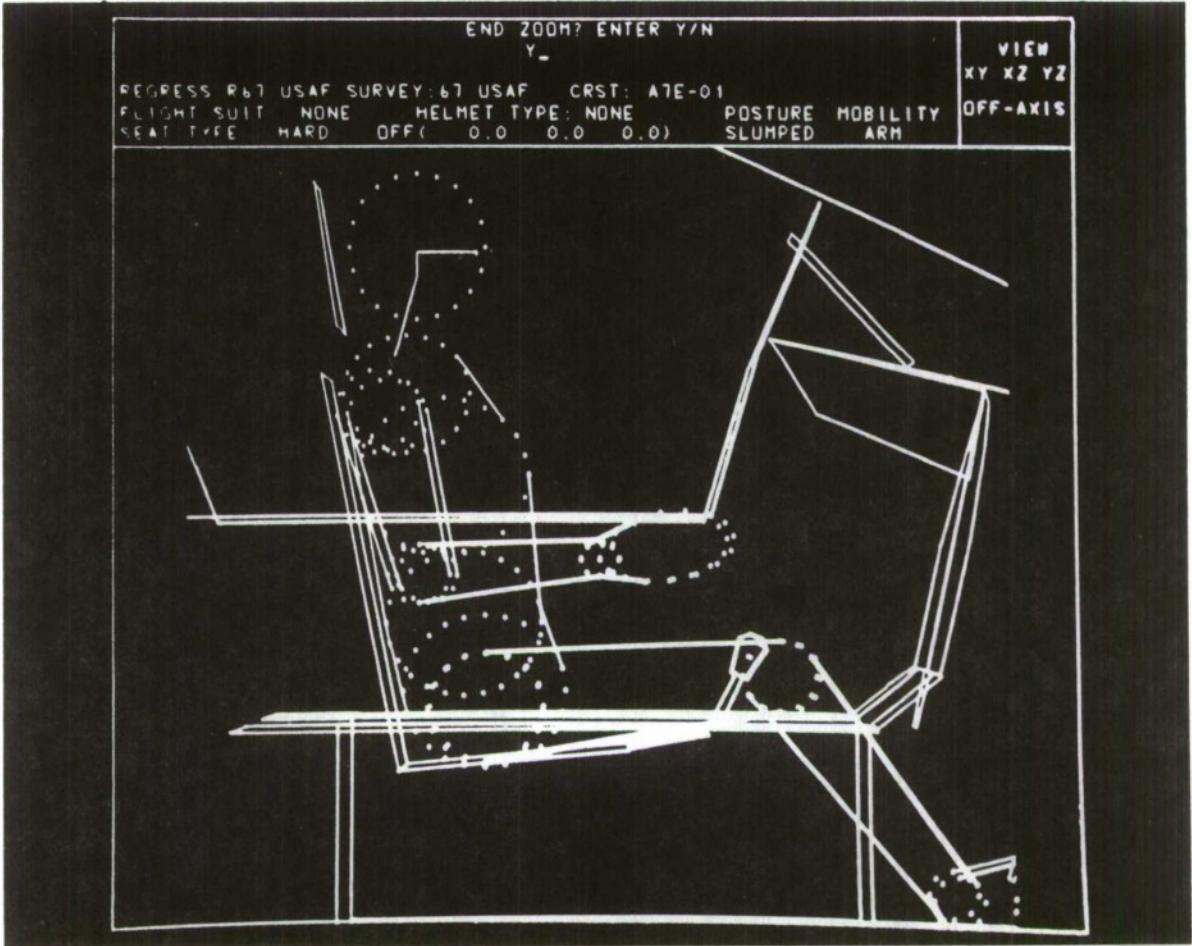

Figure 65. The "ZOOMED" Display. Choose Option to Continue or to End ZOOM on the "ZOOMED" Display.

display will remain in the zoom state until execution of another function causes regeneration of the display. Note that in order to return the display to the normal scaling and perspective at the termination of the ZOOM function, State Switch 21 must be set "ON", prior to depressing PFK28 to execute the ZOOM function.

When the user answers "N" or "NO" to the prompting message, "END ZOOM? ENTER Y/N" the message "DEFINE ZOOM WINDOW" is displayed. The user then defines a new zoom window on the already zoomed-in display. The ZOOM process continues until an ALT-CODE/5 sequence is detected for the lower left corner of the zoom window, or a response other than "N" or "NO" is entered upon completion of a requested ZOOM.

### 2.2.25 STATE SWITCH Function (PFK29)

The STATE SWITCH function allows the user to specify the state in which to run the program CBM05. Table 4 shows the various state switches available and the meanings of their states.

When this function is selected by depressing PFK29, the message "ENTER SWITCH NUMBER" is displayed. The user must enter the switch number from the ANKB followed by the ALT-CODE/5 sequence. Then the message "ENTER ON OR OFF" is displayed. The user must respond "ON" or "OFF" from the ANKB to invoke the state detailed in Table 4.

When switch 16 is chosen, and is set "ON", the message "ENTER ENFLESHMENT DENSITY CODE" is displayed. The user enters any number from 1 to 4 for increased enfleshment point density, any negative value for decreased enfleshment point density, and 0 for normal enfleshment from the ANKB and follows it by ALT-CODE/5 sequence. The man-model is displayed with the new enfleshment density. If switch 16 is set "OFF", the default value of "0" is chosen and the man-model is displayed with the normal enfleshment density. The man-model display with enfleshment density code "4" is shown in Figure 66.

TABLE 4  
PROGRAM CBM05 USER ACTIVATED STATE SWITCHES

SWITCH NUMBER	IF ON	IF OFF
2	Prints crew station data.	Does not print crew station data-
3	The entire COMBIMAN link system is displayed.	Only the neck, head, and eye links are displayed
4	Prints 12 independent anthropometric dimension values on unit 6.	No printed output.
5	No enfleshment on man-model. (Link system only.)	Enfleshed man-model is displayed.
6	Print surface dimensions and computed internal link lengths. (As in Figures 67 and 68.)	Suppress printing surface and link length data.
10	Reset default conditions when PFK26 activated for roll, pitch, and yaw angles.	Use default conditions for PFK26.
16	Allows to change enfleshment density code for man-model.	Default value for enfleshment density code '0' is assumed.
20	Prints coordinate data of visibility plot as in Figure 33.	No printed output.
21	Zoomed display does not stay.	Zoomed display stays.
22	12 Anthropometric dimensions input from cards (COMBIMAN.SMPLANTH).	12 Anthropometric dimensions cannot be input from cards.
72	Matrices (link) printed, as shown in Figure 69.	No printed output.

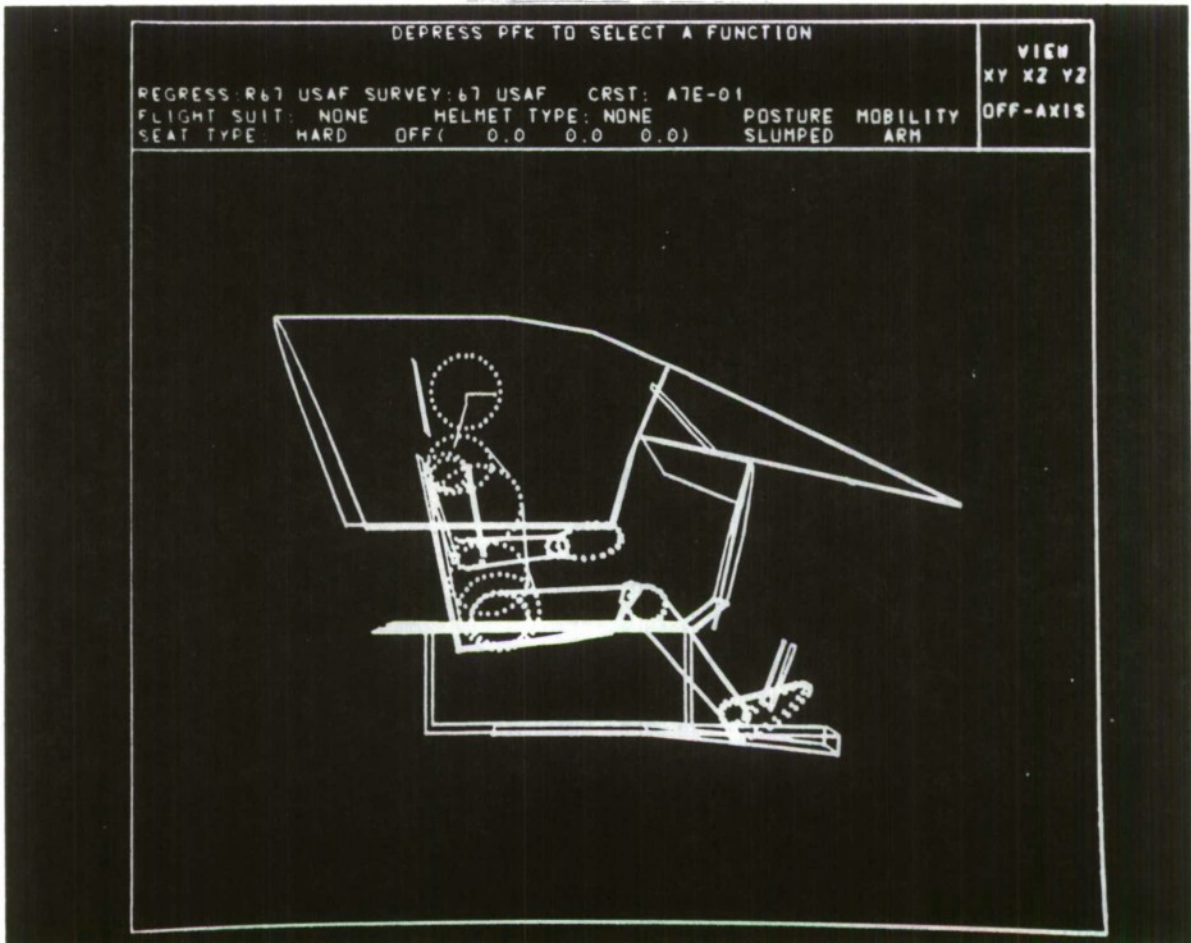

Figure 66. Man-Model with Enfleshment Density Code 4  
(Default Enfleshment Density Code is 0).

COUMIMAN LINK DATA

REFERENCED SURVEY OF REGRESSION EQUATIONS IS K67 USAF  
 REFERENCED SURVEY OF ANTHROPOMETRIC DIMENSIONS IS 67 USAF

NO.	LINK NAME	LENGTH	REF.	ANTH. DIM.	A-LENGTH	A-OFFSET	B-LENGTH	B-OFFSET	C-LENGTH	C-OFFSET
0	SRP	0.0			0.0	0.0	0.0	0.0	0.0	0.0
1	SRP-MHIF	5.75		BUTTOCK-KNE LGTH	4.582	-0.580	7.413	0.0	4.582	0.652
2	STOMACH	5.18		ALCKMION HGT/SIT	4.367	0.713	6.067	0.0	4.367	0.138
3	CHFT	5.47		SITTING HEIGHT	4.808	2.027	6.431	0.0	4.808	-0.395
4	LWR NECK	7.49		SITTING HEIGHT	3.611	0.467	8.008	0.0	3.611	-2.228
5	UPR NECK	5.21		SITTING HEIGHT	0.0	0.0	0.0	0.0	0.0	0.0
6	HD FEAD	1.40		SITTING HEIGHT	3.885	0.0	3.042	0.0	4.471	0.340
7	MH-MEYE	3.34		SITTING HEIGHT	0.0	0.0	0.0	0.0	0.0	0.0
8	MEYE-REY	1.25			0.0	0.0	0.0	0.0	0.0	0.0
9	MEYE-LEY	1.25			0.0	0.0	0.0	0.0	0.0	0.0
10	LN-MIDSS	3.23		SITTING HEIGHT	0.0	0.0	0.0	0.0	0.0	0.0
11	MSS-RSS	1.00			0.0	0.0	0.0	0.0	0.0	0.0
12	RSS-RSLC	8.26		BIACROMIAL BRDTH	0.0	0.0	0.0	0.0	0.0	0.0
13	RSUR	0.0			2.305	0.0	2.304	0.0	2.074	-0.300
14	RUPARM	10.93		SHULDR-ELB LGTH	1.729	0.553	1.729	0.0	1.729	-0.837
15	RLWRM	10.56		ELBLW-WRIST LGTH	1.100	0.0	1.100	0.0	1.100	0.0
16	RGRIPTR	2.00		HAND LENGTH	2.005	0.0	0.540	0.0	3.760	1.760
17	RFRGF	4.69		HAND LENGTH	0.0	0.0	0.0	0.0	0.0	0.0
18	RFRGTIP	7.52		HAND LENGTH	0.0	0.0	0.0	0.0	0.0	0.0
19	MSS-LSS	1.00			0.0	0.0	0.0	0.0	0.0	0.0
20	LSS-LSLD	8.26		BIACROMIAL BRDTH	0.0	0.0	0.0	0.0	0.0	0.0
21	LSLDR	0.0			0.0	0.0	0.0	0.0	0.0	0.0
22	LUPARM	10.93		SHULDR-ELB LGTH	2.305	0.0	2.304	0.0	2.074	-0.300
23	LLWRM	10.56		ELBLW-WRIST LGTH	1.729	0.553	1.729	0.0	1.729	-0.837
24	LGRIPTR	2.00		HAND LENGTH	1.100	0.0	1.100	0.0	1.100	0.0
25	LFRGF	4.69		HAND LENGTH	2.005	0.0	0.540	0.0	3.760	1.760
26	LFNGRTIP	7.52		HAND LENGTH	0.0	0.0	0.0	0.0	0.0	0.0
27	MHIP-RHP	3.43		HIP BREADTH	0.0	0.0	0.0	0.0	0.0	0.0
28	RUPRLLG	17.02		BUTTOCK-KNE LGTH	3.240	-0.166	3.240	0.0	4.097	-0.118
29	RLWRLEG	16.15		KNEE HGT/SITTING	2.156	0.0	2.156	-0.105	2.156	-0.105
30	RNK-RRKH	4.21		KNEE HGT/SITTING	1.400	0.0	1.400	0.0	1.400	0.0
31	MHIP-LHF	3.43		HIP BREADTH	5.315	-3.306	1.921	0.0	4.097	-0.118
32	LUPRLEG	17.02		BUTTOCK-KNE LGTH	3.240	-0.166	3.240	0.0	4.097	-0.118
33	LLWRLEG	16.15		KNEE HGT/SITTING	2.156	0.0	2.156	-0.105	2.156	-0.105
34	LNK-LRKH	4.21		KNEE HGT/SITTING	1.400	0.0	1.400	0.0	1.400	0.0
					5.315	-3.306	1.921	0.0	1.277	0.0

Figure 67. Surface Dimensions and Internal Link Lengths Calculated by CBM05.

COMBIMAN ANTHROPCOMETRIC DATA

REFERENCED SURVEY OF REGRESSION EQUATIONS IS R67 USAF  
 REFERENCED SURVEY OF ANTHROPCOMETRIC DIMENSICNS IS 67 USAF

-USER SUPPLIED INDEPNDNT VALUES-		-CNVRTD CFLT-	
VBL. NAME	VALUE UNIT	VALUE	UNIT
SITTING HEIGHT	50 PCT	36.65C	IN
WEIGHT	50 PCT	172.42C	LB
---COMPUTER CALC. DEP. VALUES---			
NO.	VBL. NAME	VALUE	UNIT
1	WEIGHT	172.420	LB
2	SITTING HEIGHT	36.650	IN
3	ACROMIEN HGT/SIT	24.012	IN
4	KNEE HGT/SITTING	21.940	IN
5	BUTTCK-KNE LGTH	23.771	IN
6	SHULDR-ELB LGTH	14.143	IN
7	BIACROMIAL BRDTH	16.015	IN
3	HIP BREADTH	13.851	IN
9	CHEST DEPTH	9.625	IN
10	FOOT LENGTH	10.631	IN
11	HAND LENGTH	7.520	IN
12	ELBCK-WRIST LGTH	11.802	IN

Figure 68. Printed Output of the Two Selected Independent Variable Values Calculated by CBM05.

STOMACH • HIERARCHY= 3

```

---
I 0.9+ 0.0 -0.35 I I 0.59 0.0 0.81 I I 0.27 0.0 -0.96 I
I 0.0 1.00 0.0 I = I 0.0 1.00 0.0 I X I 0.0 1.00 0.0 I
I 0.35 0.0 0.94 I I -0.81 0.0 0.59 I I 0.96 0.0 0.27 I
---

```

```

---
I 2.71 I I 0.94 0.0 -0.35 I I 0.0 I I 4.41 I
I 0.0 I = I 1.00 0.0 I X I 0.0 I + I 0.0 I
I 7.78 I I 0.35 0.0 0.94 I I 4.85 I I 3.24 I
---

```

STOMACH • HIERARCHY= 3 JOINT CENTER ROTATED BY ROLL, PITCH, YAW

```

---
I 0.0 I I 0.0 1.00 0.0 I I 2.71 I
I -2.71 I = I -1.00 0.0 I X I 0.0 I
I 7.78 I I 0.0 0.0 1.00 I I 7.78 I
---
5.46 -3.04 7.96 -5.46 -3.04 7.96 0.0 -3.04
11.84 0.0 -3.04 4.08 1.35 -3.04 11.71 -1.35
-3.04 4.20 1.35 -3.04 4.20 -1.35 -3.04 11.71
2.63 -3.04 11.35 -2.63 -3.04 4.57 2.63 -3.04
4.57 -2.63 -3.04 11.35 3.76 -3.04 10.77 -3.76
-3.04 5.14 3.76 -3.04 5.14 -3.76 -3.04 10.77
4.65 -3.04 10.00 -4.65 -3.04 5.92 4.65 -3.04
5.92 -4.65 -3.04 10.00 5.25 -3.04 9.05 -5.25
-3.04 6.86 5.25 -3.04 6.86 -5.25 -3.04 9.05
---

```

Figure 69. Transformation Equation Developed for Positioning Stomach Link (Set State Switch 72 ON).

## 2.2.26 RESTART PROGRAM Function (PFK30)

The RESTART PROGRAM function allows the user to start program CBM05 over again. When this function is evoked, all State Switches, Anthropometric dimensions, and crew station data must be redefined. Note that any modifications made to link lengths, link angles, or crew station definitions before depressing PFK30 are lost. The message "CBM003I PROGRAM RE-START" is written on output unit 8.

### 2.2.27 END PROGRAM Function (PFK31)

The END PROGRAM function displays the COMBIMAN Banner and terminates the program CBM05, prints data on output unit 6 and messages on output unit 8.

THE END

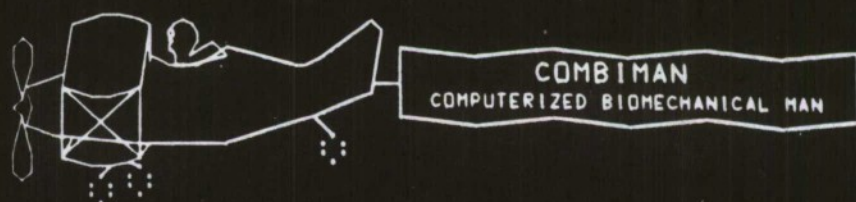

PROPERTY OF  
AFAMRL

DEVELOPED BY  
UDRI

END OF COMBIMAN PROGRAM.

## 2.3 EXECUTING THE JOB

This sequence is intended to assist the user to load the program CBM05, to specify processing, to handle error procedures, to obtain output, and to end the program run. It will not describe data formats and program functions because they are described in detail in Paragraph 2.2 of this section.

### 2.3.1 Loading the Program CBM05

The Job Control Cards to load the program CBM05 are shown in Figure 70. The program begins execution of CBM05 by displaying the COMBIMAN banner. When the user depresses PFK0, "enabled" PFKs light up and the message "DEPRESS PFK4 TO SELECT ANTH DATA" is displayed. Now the user can begin processing the man-model by depressing PFK4 to select anthropometry. The processing performed by enabled or lighted function keys are explained in Paragraph 2.2.

Anthropometric and crew station geometry data necessary to execute the interactive program CBM05 are created and maintained by the programs CBMAM, CBMCM, and CBMVM described in Sections 4, 5, and 6. The user may select data from these data bases or may modify them to suit the situation. All interactions with the program are done through the Program Function Keyboard, the Alphanumeric Keyboard, and the Light Pen.

### 2.3.2 Error Procedures

The program CBM05 performs some preliminary error checking on the data supplied by the user. The majority of checking is performed for data values which are outside the limits built into the program or the wrong type (i.e. alpha or

```

//CCMBIMAN JCB FEU
//JCBLIB DD DSN=CCMBIMAN.LCADDL0,DISP=SHR
//STEP1 EXEC PGM=CCMCS,REGION=550K
//*****
//**
//** THE INITIALIZATION, ANTI-ROFCMETRIC, CREW STATION,
//** AND VISIBILITY MEMBER DATA SETS ARE ASSUMED TO BE
//** LN DISK AND CATALOGED.
//** THEIR UCB PARAMETERS ARE SUPPLIED ON COMMENT CARDS
//**
//*****
//SYSUT1 DD SPACE=(TRK,(40)),UNIT=SYSDA
//** WCPKSPACE FOR GCUCL PLOTTER
//SYSPLCT DD SYSOUT=A
//** MESSAGE UNIT FOR GCUCL PLOTTER
//**
//** ONLINE GCUCL 5000 PLCTER
//FTJ1F001 DD DSN=CCMBIMAN.INITDATA,DISP=SHR
//** DCB=(RECFM=VB5,LRECL=150,BLKSIZE=3200)
//** SPACE=(3200,(8,1),RLSE)
//FTJ2F001 DD DSN=CCMBIMAN.ANTHDATA,DISP=SHR
//** DCB=(RECFM=F,LRECL=248,BLKSIZE=248)
//FTJ3F001 DD DSN=CCMBIMAN.CRSTDATA,DISP=SHR
//** DCB=(RECFM=F,LRECL=300,BLKSIZE=300)
//FTJ5F001 DD DSN=CCMBIMAN.SMPLANTH,DISP=SHR
//** CARD IMAGE
//FTJ6F001 DD SYSOUT=A
//FTJ7F001 DD SYSOUT=B
//FTJ8F001 DD DISP=(,PASS),SPACE=(1210,(50,20)),UNIT=SYSDA,
//** DCB=(LRECL=121,RECFM=FB,BLKSIZE=1210)
//** TEMPRARY DATA SET
//FTJ9F001 DD DSN=CCMBIMAN.VISBDATA,DISP=SHR
//** DCB=(RECFM=F,LRECL=240,BLKSIZE=240)
//FTJ0F001 DD UNIT=225C
//** IBM DISPLAY UNIT 225C-3
//FTJ1F001 DD DSN=CCMBIMAN.PLTDATA,DISP=SHR
//** DCB=(RECFM=FB,LRECL=80,BLKSIZE=800)
//** OFF-LINE PLCT DATA SET
//SYSABEND DD SYSOUT=A
//STEP2 EXEC PGM=IEBGENER,COND=EVEN
//** PRINTS MESSAGES
//SYSPRINT DD DUMMY
//SYSIN DD DUMMY
//SYSUT1 DD DSN=*,STEPI.FTJ8F001,DISP=(GLC,DELETE)
//SYSUT2 DD SYSOUT=A,DCB=(BLKSIZE=121,RECFM=FA)
//
//
00001300
00001100
00001200
00001300
00001400
00001500
00001600
00001700
00001800
00001900
00002000
00002100
00002200
00002300
00002400
00002500
00002600
00002700
00002800
00002900
00003000
00003100
00003200
00003300
00003400
00003500
00003600
00003700
00003800
00003900
00004000
00004100
00004200
00004300
00004400
00004500
00004600
00004700
00004800
00004900
00005000
00005100
00005200
00005300
00005400
00005500
00005600

```

Figure 70. JOB CONTROL CARDS to Execute CBM05.

numeric). For example: State Switch numbers must be between 1 and 72; the maximum number of panels for any crew station configuration to be displayed cannot exceed 250; and all anthropometric dimensions entered must be positive values. When the user light-pens or types in values which are out of range, the program prompts the user to retry the entry. Numerical values can be typed with or without a decimal point, at the user's option.

Example 1. Enter State Switch number "3".

This can be done in any one of the following ways.

- (a) Type "3" and depress ALT-CODE/5.
- (b) Type "3." and depress ALT-CODE/5.
- (c) Type "3.0" and depress ALT-CODE/5.

If the program expects a whole number, decimal values are rounded off to the nearest Integer. Example 3.4 and 2.7 are rounded off to 3.

If the program expects two decimal places, the input number is rounded off accordingly.

Example 2. Change a value in the link table from 10.50 to 11.32.

Light-pen 10.50, then Type "11.32" and depress ALT-CODE/5.

Typing "11.319" or "11.3215" and depressing ALT-CODE/5 has the same effect as entering 11.32.

If a Program Function Key is depressed the corresponding function as described in Paragraph 2.2 is enabled. However, if a key is pressed erroneously, the following procedure may be followed to return to the main program.

For Program Function Keys 0, 1, 2, 3, 6, 7, 8, 11, 14, 16, 18, 28, and 29 depress ALT-CODE/5 to cancel the selected function.

With Program Function Keys 4, 12, 13, and 27, the function must be executed.

For Program Function Key 5, light-pen "\*\*NONE\*\*" in the display to cancel the execution of the RETRIEVE CREW STATION function.

For Program Function Keys 9, 15, 23, 24, 25, 26, 30, and 31, the functions are executed as soon as the PFKs are depressed.

For Program Function Key 22, depress the temporarily defined PFK2 or PFK10 to return to the main graphics routine.

### 2.3.3 Ending the Program CBM05

There are three ways to end program CBM05. The primary method for terminating the program is through CBM05, by depressing the END PROGRAM function key PFK31. This option can be exercised only when the message "DEPRESS PFK TO SELECT A FUNCTION" appears in the Prompting Area of the CRT. Another method to terminate execution of the program is to use the CANCEL key on the IBM 2250 Alphanumeric Keyboard. When CANCEL key and ALT CODE key are depressed together, the three options shown in Figure 71 are displayed.

Light-penning the "TERMINATE" option terminates the program without producing a memory dump of program CBM05. The "DUMP" option terminates the program and produces a full storage dump. The "RESUME" resumes the execution of program CBM05 as though the CANCEL key had not been used. This option is provided by the system and can be used at any time.

The third option is to cancel the JOB from the computer operator's console. This is a system dependent option.

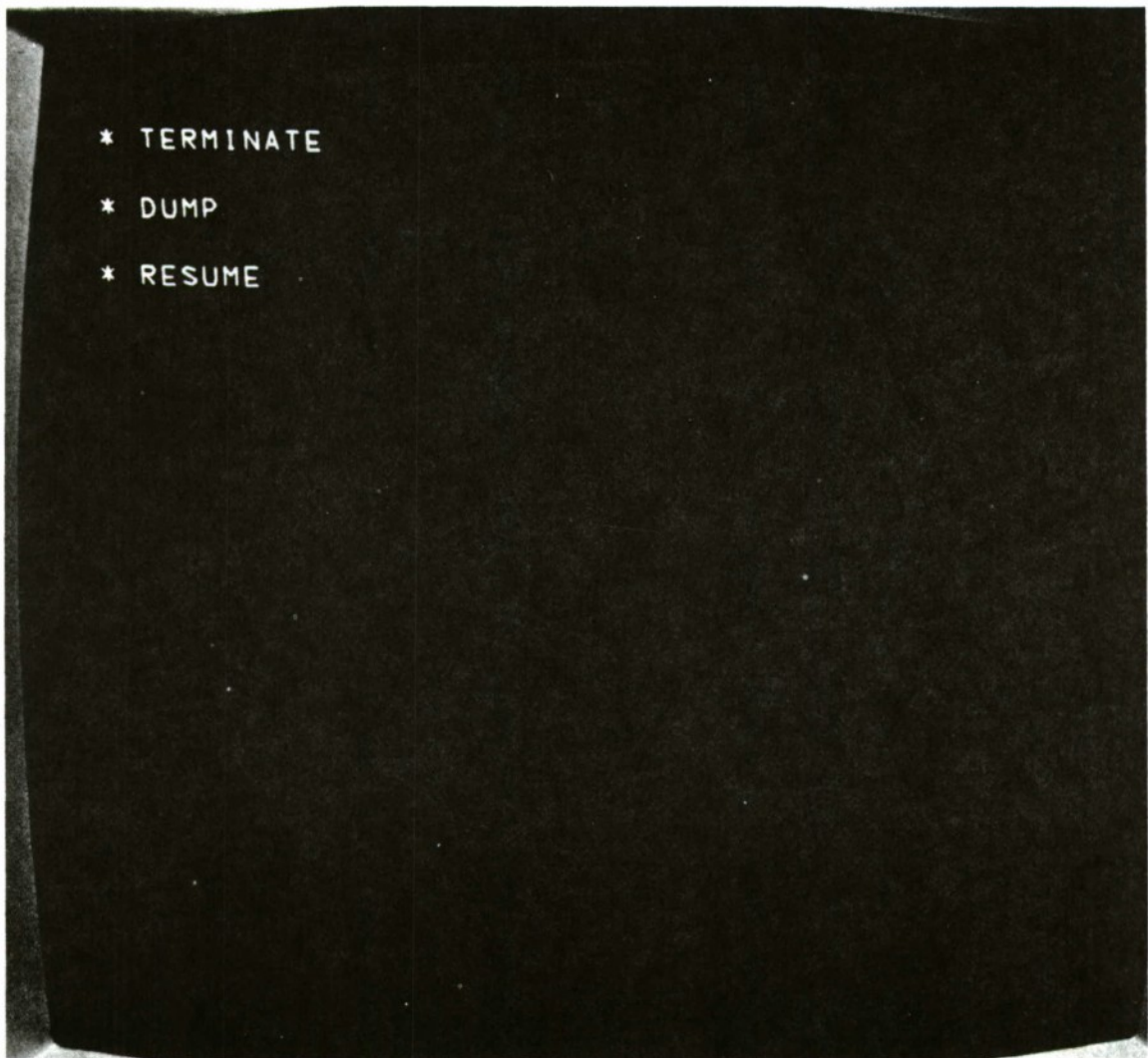

Figure 71. Options Displayed on Depressing ALT CODE and CANCEL Keys Together.

## 2.4 PROGRAM MESSAGES-INFORMATION AND ERROR TYPES

The program CBM05 prints out both information and action oriented messages. The message format is as follows:

CBM0nni	<u>Message Text</u>
where:	
CBM	identifies the message and indicates that the message originates from the COMBIMAN system,
0	identifies the message and indicates that the message originates from the program CBM05,
nn	is the message number,
i	is the action code (I=information, A=action to be performed), and
Message Text	is the message text.

The messages are as follows:

CBM001I      COMBIMAN V5, DATE=MM/DD/YY, TIME=hh.mm.ss.  
              Issued By:        CBMINT.  
              Reason:            Program CBM05 started at this date  
                                  and time.  
              System Action:    Execution continues.  
              User Action:       None.

CMB002I      PROGRAM END.  
              Issued By:        CBMRTS.  
              Reason:            The user requested the END PROGRAM  
                                  function.  
              System Action:    The program ended as requested.  
              User Action:       None.

CBM003I      PROGRAM RESTART  
              Issued By:        CBMRTS.  
              Reason:            The user requested the RESTART PRO-  
                                  GRAM function.  
              System Action:    The program restarted as requested.  
              User Action:       None.

CBM007I      panel number.) panel name, TYPE=nn, nn VERTICES.  
              Issued By:        CBMPNL or CBMCRW  
              Reason:            The user defined a panel through the  
                                  DESIGN PANEL function.  
                                  or  
                                  The User requested the crew station  
                                  data by setting state switch 2 ON.  
              System Action:    The defined panel is accepted or the  
                                  crew station data are printed.  
              User Action:       None.

CBM009I      SWITCH switchnumber ON/OFF  
              Issued By:        CBMSSW.  
              Reason:            The user requested a change in the  
                                  execution of the program using the  
                                  STATE SWITCH function.  
              System Action:    Switch switchnumber is now either  
                                  "ON" or "OFF."  
              User Action:       None.

CBM010I IDENTIFIED objectname  
 Issued By: CBMIOI.  
 Reason: The user requested the IDENTIFY OBJECT function to identify an object displayed on the screen.  
 System Action: The system displays the name of the object, the coordinates of the distal-end point, and the internal "key" number.  
 User Action: None.

CBM011I OMITTED objectname  
 Issued By: CBMIOI.  
 Reason: The user requested that an object be removed from the display using the "OMIT OBJECT" function.  
 System Action: The light penned object is removed from the screen, and the name of the object, coordinates of the distal-end point, and the internal "key" number are displayed on the screen.  
 User Action: Record the internal "key" number in order to include the object in the display at a later time.

CBM012I INCLUDED objectname  
 Issued By: CBMIOI.  
 Reason: The user requested that an object be included back into the display using the INCLUDE OBJECT function.  
 System Action: The requested object is included back into the display.  
 User Action: None.

CBM014I Crew Station DATA FROM membername  
 Issued By: CBMCRW.  
 Reason: The user requested the retrieval of a crew station definition by the RETRIEVE CREW STATION function.  
 System Action: The requested crew station member is retrieved.  
 User Action: None.

CBM015I SURVEY DATA FROM membername  
 Issued By: CBMIN1.  
 Reason: The user requested membername Survey Data from the Anthropometric Data Base.  
 System Action: The requested survey data are retrieved.  
 User Action: None.

CBM016I VIEW=(roll, pitch, yaw), SCALE=factor,  
 OFFSET=(x,y,z).  
 Issued By: CBMCVW.  
 Reason: The user requested a new off-axis  
 view through the "CHANGE VIEW" func-  
 tion.  
 System Action: The display is rotated as speci-  
 fied.  
 User Action: None.

CBM018A INITIALIZATION DATA MISSING.  
 Issued By: CBMINT.  
 Reason: Initialization Data could not be  
 found.  
 System Action: The program is terminated.  
 User Action: Check to see that the initialization  
 data set has not been destroyed.

CBM019I PLOTS COMPLETED.  
 Issued By: CBMCP1.  
 Reason: The requested hard copy plot of the  
 COMBIMAN display is finished.  
 System Action: Continue processing  
 User Action: None.

CBM022A TOO MANY PANELS/VERTICES.  
 Issued By: CBMCRW.  
 Reason: More panels were defined through the  
 RETRIEVE CREW STATION function  
 (PFK5) or the DESIGN PANEL function  
 (PFK16) than could be handled at one  
 time. The maximum number of panels  
 that can be handled at one time is  
 250.  
 System Action: The panel being defined is ignored.  
 User Action: Delete a few panels by the DELETE  
 PANEL function (PFK18) or delete a  
 crew station using the RETRIEVE CREW  
 STATION function before defining  
 more panels.

CMB026I DELETE PANEL panelname.  
 Issued By: CBMDPL.  
 Reason: The user requested to delete panel  
panelname using the DELETE PANEL  
 function.  
 System Action: The panel is deleted.  
 User Action: None.

CBM031A CREW STATION DATA BASE MISSING.  
 Issued By: CBMCRW.  
 Reason: Identification record of the file containing a crew station data is missing.  
 System Action: Displays similar message to CRT and returns control to main program.  
 User Action: Stop program, if crew stations are needed.

CBM033I REGRESSION VALUES FROM MEMBER membername.  
 Issued By: CBMIN1.  
 Reason: User entered a valid regression or type 0 anthropometric data base membername using light pen.  
 System Action: Data from the referenced member are read.  
 User Action: None.

CBM034A ANTHROPOMETRIC DATA BASE MISSING.  
 Issued By: CBMINT, CBMIN1.  
 Reason: The identification record of the file which contains anthropometric data is missing.  
 System Action: Displays similar message on CRT and returns control to main program.  
 User Action: Stop program; create anthropometric data base.

CBM035A VARIABLE NO. nn OF REGRESSION SURVEY membername HAS INVALID UNIT OF uu.  
 Issued By: CBMIN1.  
 Reason: The unit of measurement read in for the specified variable and survey was not either IN, CM, MM, LB, or KG.  
 System Action: Remainder of data for variable is read in.  
 User Action: Report condition to systems programmer.

CBM039I UNIT OF VARIABLE vblname HAS BEEN CHANGED TO uu.  
 Issued By: CBMIND, CBMDEP.  
 Reason: The user changed the default unit of measurement of the selected variable.  
 System Action: Flag the unit as being changed.  
 User Action: None.

CBM040A      INVALID UNIT OF uu SPECIFIED FOR VARIABLE vblname.  
 Issued By:    CBMIND, CBMDEP.  
 Reason:        The variable in question was defined  
                  in the anthropometric survey as hav-  
                  ing a length or weight type of mea-  
                  surement. The unit specified by the  
                  user was not consistent with the  
                  original definition.  
 System Action: Change ignored.  
 User Action:    Specify correct unit or keep default  
                  unit.

CBM041I      INPUT VARIABLES WILL BE IN PERCENTILES.  
 Issued By:    CBMIND, CBMDEP.  
 Reason:        User has indicated that values for  
                  anthropometric variables will be  
                  given as percentiles.  
 System Action: None.  
 User Action:    None.

CBM042I      INPUT VARIABLES WILL BE IN ABSOLUTE VALUES.  
 Issued By:    CBMIND, CBMDEP.  
 Reason:        User has indicated that values for  
                  anthropometric variables will be  
                  given in engineering units.  
 System Action: None.  
 User Action:    None.

CBM043I      USER CHOOSES TO INPUT nn DEPENDENT VARIABLES.  
 Issued By:    CBMDEP.  
 Reason:        User has depressed PFK12, indicating  
                  the decision to enter values for all  
                  the dependent anthropometric vari-  
                  ables.  
 System Action: None  
 User Action:    None.

CBM044I      STANDARD ERROR MULTIPLICATION FACTOR RESET TO nnn.nn.  
 Issued By:    CBMIND.  
 Reason:        User has entered a new value for  
                  standard error of estimate.  
 System Action: Value changed internally.  
 User Action:    None.

CBM045I      USER CHOOSES TO INPUT 2 INDEPENDENT VARIABLES.  
 Issued By:    CBMIND.  
 Reason:        User has depressed PFK13, indicating  
                  the decision to enter values for two  
                  independent anthropometric variables.  
 System Action: None.  
 User Action:    None.

CBM046A ANTHROPOMETRIC DIMENSION vblname REFERENCED BY LINK  
link name DOES NOT EXIST IN MEMBER membername.  
 Issued By: CBMIN1.  
 Reason: One of the vital anthropometric di-  
 mensions needed to generate the link  
 length in question does not exist in  
 the referenced survey member.  
 System Action: Program ends.  
 User Action: Print contents of referenced member  
 from Anthropometric Data Base, using  
 PRT function of CBMAM.

CBM047A ABNORMAL PROGRAM END.  
 Issued By: CBMIN1.  
 Reason: Key data vital to the construction  
 of the man-model were not available.  
 System Action: Program ends.  
 User Action: Contact systems programmer.

CBM048I DATA WRITTEN FOR OFF-LINE PLOT NO. nn.  
 Issued By: CBMCPl.  
 Reason: Coordinate and index data for man-  
 model and crew station configuration  
 have been written onto disk file  
 specified by FT11F001 DD card. nn  
 is the plot number.  
 System Action: None.  
 User Action: None.

CBM049A I/O ERROR ON UNIT 11. OFF-LINE PLOT DATA nn NOT  
 SAVED.  
 Issued By: CBMCPl.  
 Reason: Input-output error on file where  
 coordinate data are written. Plot  
 data for plot nn are not saved.  
 System Action: Return to calling program.  
 User Action: None.

CBM052I VISIBILITY PLOT GENERATED FOR visibility member.  
 Issued By: CBMVIS.  
 Reason: Successful completion of visibility  
 plot.  
 System Action: None.  
 User Action: None.

CBM053A NUMBER OF COMBINATIONS OF INDEPENDENT VARIABLES  
 SUPPLIED BY MEMBER survey name DOES NOT EQUAL THAT  
 SUPPLIED BY MEMBER regression name.  
 Issued By: CBMIN1.  
 Reason: Values for number of independent  
 combinations are different from num-  
 ber supplied by regression member.  
 System Action: Values supplied by regression member  
 are used.  
 User Action: Contact systems programmer.

CBM054A      NUMBER OF DEPENDENT VARIABLES SUPPLIED BY MEMBER  
survey name DOES NOT EQUAL THAT SUPPLIED BY MEMBER  
regression name.  
 Issued By:      CBMIN1.  
 Reason:          Values for number of dependent vari-  
                   ables are different from number sup-  
                   plied.  
 System Action:  Values supplied by regression member  
                   are used.  
 User Action:     Contact systems programmer.

CBM055I      UNIT 9 NOT A VISIBILITY DATA BASE.  
 Issued By:      CBMVIS.  
 Reason:          Identification record of Visibility  
                   Data Base is missing.  
 System Action:  Terminates Visibility Plot Function.  
 User Action:     Stop program if Visibility Plot is  
                   needed.

CBM056I      TOO MANY VERTICES nn FOR BOUNDARY boundary name.  
 Issued By:      CBMVIS.  
 Reason:          The number of vertices on boundary  
                   exceeded 100.  
 System Action:  Unpredictable result on Visibility  
                   Plot.  
 User Action:     Limit number of vertices on any one  
                   boundary to 100.

CBM057I      TO MANY POINTS nn FOR BOUNDARY boundary name.  
 Issued By:      CBMVIS.  
 Reason:          The number of points on any boundary  
                   exceeded 2500 (ie. the perimeter of  
                   the boundary exceeded 2500 inches).  
 System Action:  Unpredictable result on Visibility  
                   Plot.  
 User Action:     Limit the perimeter of the boundary  
                   to 2500 inches.

CBM058I      END OF DATA ON UNIT 9.  
 Issued By:      CBMVIS.  
 Reason:          Insufficient data on Unit 9 to gene-  
                   rate visibility plot.  
 System Action:  Return to calling program.  
 User Action:     Contact systems programmer.

SECTION 3  
OFF-LINE PLOT PROGRAM (CBMOFF)

The CBMOFF is an off-line plot program which plots COMBIMAN data displayed on the IBM 2250 screen. When the user needs a plot which cannot be done On-Line,<sup>1</sup> the OFF-LINE PLOT COMBIMAN function (PFK7) is depressed to store the man-model and crew station data of the display currently on the CRT (see Paragraph 2.2.8). The user may store as many sets of these data as needed on data set unit 11 (see FT11F001 DD card on Figure 70). Program CBMOFF plots these data using Calcomp compatible software. The user specifies the data sets to be plotted, as well as plot size, color, and content.

The following information is intended as a programmer's guide to use the program CBMOFF.

### 3.1 AVAILABLE PROCESSING

The user specifies the contents and size of the plot as well as its color. This is done by providing the following two input cards along with the plot data file.

- (1) the NAMELIST/CNTRL/, and
- (2) a card with the plot numbers of those data sets not to be plotted.

The information supplied on these cards allows the user to vary plot size, plot color, and plot content as follows:

<sup>1</sup>At WPAFB AFAMRL we use a, 10" Model 5000 Gould electrostatic plotter for On-Line plots and a 3-color 30" Calcomp plotter with a resolution of 0.0002" for report quality output and quarter-scale Off-Line plots.

- (1) The NAMELIST/CNTRL/'s variables and their default values:

FACTR - When specified, FACTR is the plot scale factor for that program run, otherwise, the scale factor specified for each plot during the COMBIMAN run when the data were generated (see Paragraph 2.2.8) is used.

LINKS, FLESH, and CRST - These three variables allow user to eliminate the link system, the enfleshment, and/or the crew station respectively from plots for that program run. Specifying LINKS, FLESH, and/or CRST equal to "1" deletes that element(s) from the plots. Using the default values

LINKS=0  
FLESH=0, and  
CRST=0

all elements on the CRT display are plotted.

(ICOLOR(I), I=1,4) - ICOLOR(I) determines the pen color for element "I" of the plot where,

I=1 is the plot banner,  
I=2 is the link system,  
I=3 is the enfleshment, and  
I=4 is the crew station.

The default<sup>2</sup> values of the pen colors for plot banner, link system, enfleshment and crew station are:

ICOLOR(1)=1 for banner,  
ICOLOR(2)=1 for link system,  
ICOLOR(3)=2 for enfleshment, and  
ICOLOR(4)=3 for crew station.

---

<sup>2</sup>When an off-line plot is made, the user specifies the color assignments.

The format of the Namelist CNTRL is as follows (see Figure 72):

```
column 1   - a blank
column 2   - a $3
column 3-7 - the word CNTRL
column 8   - a blank
```

After column 8 comes none, all, or any combination of the keyword control variables in the form FLESH=1, FACTR= .95, ICOLOR(2)=3, ..., the last one followed by a "\$" indicating the end of the NAMELIST variable input.

- (2) The second data card contains the plot numbers of the data to be skipped. The format for the data card is shown in Figure 73. The data card can contain up to twenty plot numbers, each right-justified integer in one of the 3-character fields in the first sixty columns of the card. These numbers can be in any order and do not need to fill consecutive fields. If the card is left blank, no plot will be skipped.

Figure 74 shows an Off-Line plot of the man-model with full skeletal link system and a crew station, as it appears on the CRT. The plot banner shown in Figure 75 indicates that the plot is a perspective plot with scale factor 0.85. The data card input for this plot is shown in Figure 76. Notice that all values except ICOLOR(3) and ICOLOR(4) remain at their default values in the NAMELIST/CNTRL/. This implies that the scale factor for the plot is the one specified during the COMBIMAN run when the plot data were generated. The link system, enfleshment, and crew station as displayed on the CRT are included in the plot. Since both ICOLOR(3) and ICOLOR(4) are

---

<sup>3</sup>The \$ symbol is used while executing the program on a CDC computer: other computers may have different symbols for this purpose.

\$ CNTRL			None, all, or any combination of the Namelist CNTRL's variables, separated by commas.														\$													
1	2	3	4	5	6	7	8	9	0	1	2	3	4	5	6	7	8	9	0	1	2	3	4	5	6	7	8	9	0	
8	9	9	9	9	9	9	9	9	9	9	9	9	9	9	9	9	9	9	9	9	9	9	9	9	9	9	9	9	9	9

Figure 72. The Format of the Namelist CNTRL.

Plot numbers of those plots not one of the three-digit fields.			each right justified in																											
1	2	3	4	5	6	7	8	9	0	1	2	3	4	5	6	7	8	9	0	1	2	3	4	5	6	7	8	9	0	
9	9	9	9	9	9	9	9	9	9	9	9	9	9	9	9	9	9	9	9	9	9	9	9	9	9	9	9	9	9	9

Figure 73. The Format of the Data Card for Unwanted Plots.

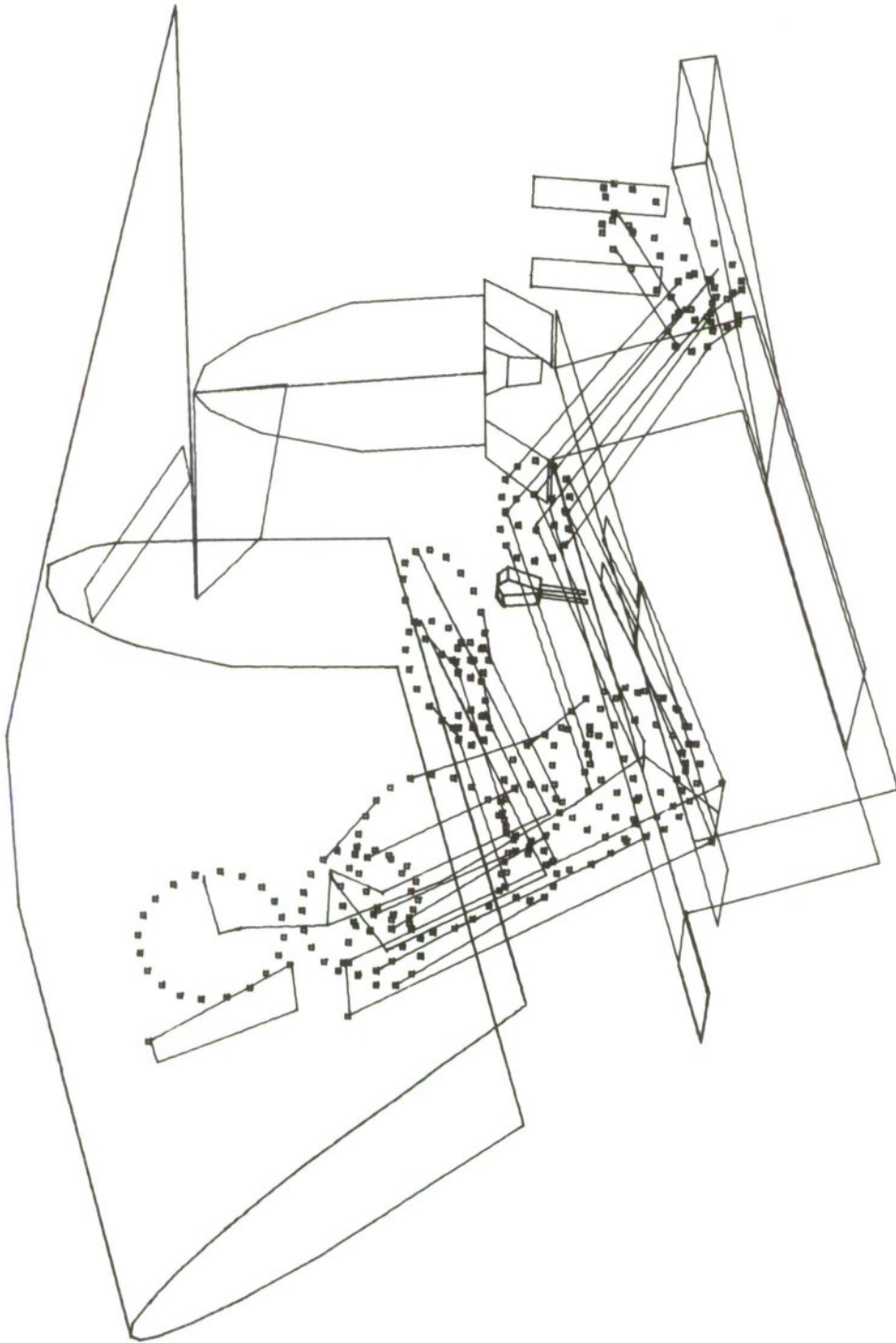

Figure 74. COMBIMAN OFF-LINE Plot.

```
REGRES: R67 USAF
SURVEY: 67 USAF
CRST: A7E-01
VIEW-PLANE: OFF AXIS
ROLL PITCH YAW
0.0 -15.0 15.0
PERSPECTIVE
SCALE=0.85
PLOT=2
```

Figure 75. Plot Banner for the Plot Shown in Figure 74.



set equal to 1 in the input, all elements of the plot will be of the same color (in this case black). Also notice that the second input card contains a "1" in column six denoting that plot number 1 is to be skipped. The plot shown in Figure 74 is plot number "2" as indicated in Figure 75.

Figure 77 shows the input cards used to generate Figure 78 from the same plot data. FACTR=0.55 resets the plot scale factor to 0.55, FLESH=1 deletes all enfleshment from the man-model, and the color of all plot elements is again black.

### 3.2 PROGRAM MESSAGES-INFORMATION AND ERROR TYPE

The program CBMOFF prints both information and action related messages. The message format is as follows:

CBM2nni                    message text

where:

CBM	identifies the message and indicates that the message originates from COMBI-MAN system
2	identifies the message and indicates that the message originates from the program CBMOFF
nn	is the message number
i	indicates the action code (I=Informational, A=Action to be performed), and
<u>message text</u>	is the text of the message

```
CBM201I    PLOT SET plotnumber WAS NOT PLOTTED -- BY REQUEST.
           Reason:            User requested that plot plotnumber
                               not be plotted.
           System Action:    Plot plotnumber is not plotted.
           User Action:       None.
```

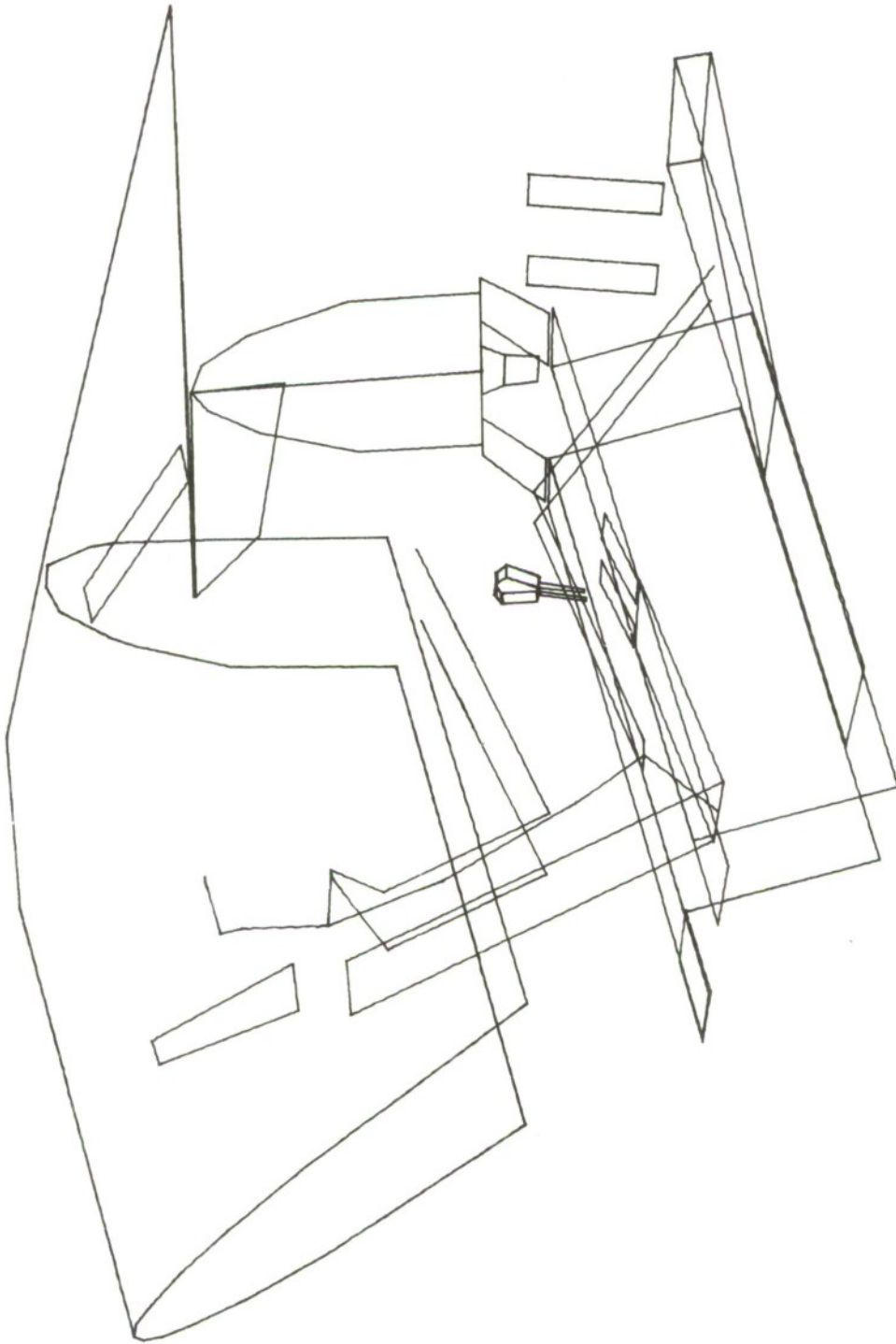

Figure 78. Altered COMBIMAN OFF-LINE Plot.

CBM202A      INCORRECT AMOUNT OF DATA FOR PLOT plotnumber --  
PROGRAM ENDING.  
Reason:            There were too much or too little  
                    data on file for plot plotnumber.  
System Action:    No plotting occurs, and program ends.  
User Action:      Recreate plot file.

CBM203I      SCALE FACTOR CHANGED FROM factor1 TO factor2.  
Reason:            User input a value for FACTR  
                    (factor2) in the namelist CNTRL.  
System Action:    factor2 is used to scale the plot.  
User Action:      None.

SECTION 4  
COMBIMAN ANTHROPOMETRIC DATA BASE MAINTENANCE  
PROGRAM (CBMAM)

In order to generate an accurate and sophisticated man-model like the one in COMBIMAN, the user is often requested to supply a lot of anthropometric data. To simplify this task, a Data Base is constructed to store key data items. This Data Base resides on a direct-access disk, and contains anthropometric survey and regression data which are relevant to generate the man-model.

The information on the Data Base is organized into groups of related records called members. Members may be either regression data, or anthropometric survey data. Data for survey members are generally subsets of existing anthropometric surveys in the AFAMRL Anthropometric Data Bank. In order to add a new anthropometric survey to the Data Base, the key information needed includes the mean and standard deviation for each anthropometric variable and a set of correlation coefficients for all the relevant variables of the survey.

#### 4.1 AVAILABLE PROCESSING

The program CBMAM (COMBIMAN Anthropometric Data Base Maintenance Program) allows the user to create and maintain the Anthropometric Data Base. The user supplies the input data on 80 character computer cards or in card image format on magnetic tape. The program CBMAM reads and processes the data in accordance with the selection of control commands by the user. These commands allow the user to add members to the Data Base, to delete members from the Data Base, to print or punch existing members, to list the directory of the Data Base, or to compress the data on the file to combine unused space. The data flow of the program is shown in Figure 79.

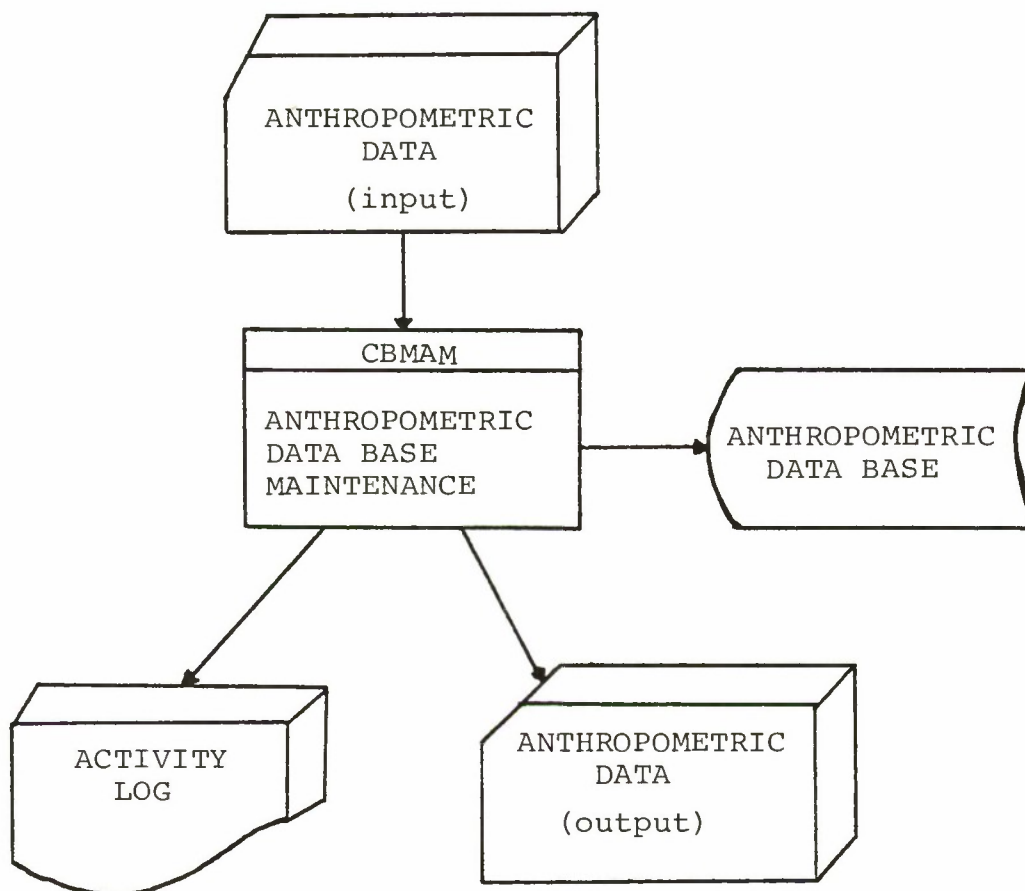

Figure 79. Data Flow for Program CBMAM.

The Anthropometric Data Base is made up of two types of related data. One type consists of regression data which is used by the interactive graphics program CBM05 to compute the anthropometric surface dimensions needed to generate the link system of the man-model. The second type consists of survey data which define the means, standard deviations, and percentiles for each variable for a particular survey. Each group of data, whether dealing with regression or survey information, is called an anthropometric member, and is referenced by its member name and type classification.

#### 4.2 RESTRICTIONS AND LIMITATIONS

The Anthropometric Data Base may contain up to a maximum of 20 members consisting of regression and survey types. The number of records for each member need not be the same and the sum of the record counts for all the members cannot exceed 1979. Information on the number of members on the Data Base and their sizes is obtained by using the "+PRT" control command as explained in detail in Paragraph 4.3.2.9

Additional limitations on the number of variables and related data are explained in Paragraph 4.3.2. Members to be added should have unique member names. If the new member name matches with any name in the directory, the member will not be added.

#### 4.3 HOW TO USE PROGRAM CBMAM

The surveys used in COMBIMAN are subsets of 1967 Survey of the USAF Flying Personnel (Churchill, et al, 1976), the 1970 Survey of the U.S. Army Aviators (Churchill, et al, 1971), the 1968 Air Force Women, and the 1964 U.S. Navy Flyers. As new surveys become available, or subsets of existing surveys in the

AFAMRL Data Bank become needed, the program CBMAM is used to add these new members. In most cases, each new survey type member has a corresponding regression type member which contains multiple and single regression equation coefficients to predict additional anthropometric variables from those specified by the user. In a few cases, one regression type member may be referenced by several survey type members. These are special cases and this practice should not be used regularly without first consulting with personnel in the Workload and Ergonomics Branch of the Air Force Aerospace Medical Research Lab, Wright-Patterson Air Force Base, Ohio to verify the statistical accuracy of the regression data of the anthropometric survey in question.

All examples illustrating the use of CBMAM will be based on the 1967 USAF Flying Personnel survey and its regression member R67 USAF.

#### 4.3.1 Input Data Specification

The nucleus of the anthropometric variables considered for input as part of any anthropometric survey member is the 12 variables required to generate the 35 internal link lengths of the man-model skeletal system. The names of these variables and their abbreviated 16 character names, where applicable, are listed in Table 5. Very few COMBIMAN users will have specific values to input for each of the 12 variables. In order to accommodate this, we have selected additional anthropometric variables which are found to be good predictors of either body segment mass or body segment length, and have moderately high correlations with the 12 required variables. The variables chosen to predict mass and length related variables for the 1967 Survey are shown in the appropriate columns of Table 6. The variables in Table 6 which are both predictors and required dependent dimensions are marked with an asterisk.

TABLE 5  
LIST OF DEPENDENT VARIABLES NEEDED TO GENERATE  
COMBIMAN LINK SYSTEM

<u>Name</u>	<u>16 Character Abbreviation (If Applicable)</u>
1. Weight	
2. Sitting Height	
3. Acromion Height, Sitting	(ACROMION HGT/SIT)
4. Knee Height, Sitting	(KNEE HGT/SITTING)
5. Buttock-Knee Length	(BUTTOCK-KNE LGTH)
6. Shoulder-Elbow Length	(SHOULDR-ELB LGTH)
7. Biacromial Breadth	(BIACROMIAL BRDTH)
8. Hip Breadth	
9. Chest Depth	
10. Foot Length	
11. Hand Length	
12. Elbow-Wrist Length	(ELBOW-WRIST LGTH)

TABLE 6  
LIST OF DEPENDENT VARIABLE PREDICTORS

<u>Mass Related</u>	<u>Length Related</u>
1. *Weight	1. *Sitting Height
2. Bideltoid Breadth	2. Eye Height, Sitting
3. Hip Breadth, Sitting	3. *Knee Height, Sitting
4. *Chest Depth	4. *Buttock-Knee Length
	5. Elbow-Grip Length
	6. Thumb-Tip Reach

\*Predictors and required dependent variables.

To generate the man-model the user may also select one mass related and one length related variables from Table 6 and supply their values. The values for all the 12 variables in Table 5 are computed using the regression equations from the Anthropometric Data Base.

In order to create an anthropometric survey member, first a set of variables based on availability and necessity has to be established. Once the complete set of variables is established, the means, standard deviations, percentiles, and correlation coefficients for each variable of the particular survey may be obtained from the AFAMRL Anthropometric Data Bank. The set of variables used for the 1967 Survey is shown in Table 7. A sample data obtained for Weight are shown in Figure 80.

The coefficients used in the regression equations are based on means, standard deviations and correlation coefficient for each variable, and on the equations which were developed in WADD-TR-60-31, pages 69-70 (Zeigen, et al, 1960). Tables 8 and 9 show the elements of the correlation coefficient matrices used in calculating the regression coefficients. The means, standard deviations, and correlation coefficients for 1967 USAF survey are available in AMRL-TR-77-2 (Churchill, et al, 1978).

The total number of multiple regression equations (NR) needed for a particular survey is calculated using the following equation:

$$NR = (NM \times NL) \times ND \quad (1)$$

where NM is the number of variables related to body segment mass, NL is the number of variables related to body segment length, and ND is the number of dependent variables. For 1967 Survey, each of the 24 combinations of mass-length-related

TABLE 7  
LIST OF ANTHROPOMETRIC DIMENSIONS  
AVAILABLE IN THE ANTHROPOMETRIC DATA BASE

1. Weight
2. Sitting Height
3. Eye Height, Sitting
4. Acromion Height, Sitting
5. Knee Height, Sitting
6. Buttock-Knee Length
7. Shoulder-Elbow Length
8. Elbow-Grip Length
9. Thumb-Tip Reach
10. Biacromial Breadth
11. Bideltoid Breadth
12. Hip Breadth
13. Hip Breadth, Sitting
14. Chest Depth
15. Foot Length
16. Hand Length
17. Elbow-Wrist Length

VARIABLE NAME: WEIGHT

MEAN: 173.60 LBS

STANDARD DEVIATION: 21.44 LBS

PERCENTILE DATA:

Percentile	1	2	3	5	10	15	20	25	30
Weight	127.58	132.63	135.82	140.15	146.89	151.53	155.27	158.56	161.56
Percentile	35	40	45	50	55	60	65	70	75
Weight	164.37	167.08	169.74	172.42	175.13	177.92	180.84	183.97	187.41
Percentile	80	85	90	95	97	98	99		
Weight	191.32	195.91	201.83	210.76	216.62	220.94	227.73		

Figure 80. Sample Data Obtained from Summary Statistics of the Air Force Rated Officers. (Churchill et al, 1976)

TABLE 8

MATRIX OF CORRELATION COEFFICIENTS BETWEEN  
 MASS AND LENGTH RELATED VARIABLES (CHURCHILL, ET AL, 1976)

	Sitting Height	Eye Hgt. Sitting	Knee Hgt. Sitting	Butt-Knee Length	Elbow- Grip Length	Thumb- Tip Reach
Weight	.4568	.4119	.5386	.4544	.4085	.4138
Bideltoid Brdth.	.2782	.2598	.3398	.4379	.2514	.2784
Hip Brdth., Sitting	.3755	.3457	.4283	.5502	.3432	.3270
Chest Depth	.3333	.3078	.4084	.5479	.2882	.2965

TABLE 9

## DEPENDENT AND INDEPENDENT VARIABLES (CHURCHILL, ET AL, 1976)

DEPENDENT VARIABLES	INDEPENDENT VARIABLES									
	Weight	Sitting Height	Eye Height (S)	Knee Height (S)	Buttock-Knee Length	Forearm-Hand Length	Thumb-1st Phalanx	Biacromial Breadth	Hand Breadth (S)	Chest Depth
Weight	1.00	.4576	.4130	.5390	.6361	.4080	.4143	.7966	.8549	.7594
Sitting Height	.4568	1.00	.9302	.5148	.3917	.4613	.4138	.2782	.3333	.1299
Acromion Height (S)	.4862	.8126	.7780	.4452	.3382	.3823	.3482	.2676	.3916	.2008
Knee Height (S)	.5386	.5148	.4876	1.00	.7851	.7817	.7002	.3398	.4084	.2853
Buttock-Knee Length	.6363	.3917	.3897	.7851	1.00	.6238	.6041	.4379	.5479	.4168
Shoulder-Elbow Length	.3995	.4573	.4584	.7500	.6967	.6743	.6752	.2515	.2997	.2092
Biacromial Breadth	.4516	.3491	.2964	.3745	.2954	.3481	.3235	.6571	.3202	.2681
Hip Breadth	.8094	.3755	.3457	.4283	.5502	.3432	.3270	.6225	.9031	.5803
Chest Depth	.7593	.1299	.1065	.2853	.4168	.2034	.2523	.6240	.6318	1.00
Foot Length	.4711	.4786	.4497	.6919	.5957	.6517	.5545	.3067	.3498	.2445
Hand Length	.3889	.4506	.4155	.6539	.5432	.7070	.5757	.2553	.2578	.2005
Elbow-Wrist Length	.4136	.4340	.3699	.7826	.6260	.8994	.6865	.2619	.2993	.2122

dimensions has its own set of 12 multiple regression equations to compute the surface dimensions required to generate the man-model. In addition to the multiple regression coefficients, simple regression coefficients and associated standard error of estimates are available for each of the 24 combinations. Note that the standard units of measurement for all variables used in COMBIMAN are pounds and inches, but there are provisions to change these into metric units.

#### 4.3.2 Processing Specification

The Anthropometric Data Base Maintenance program, CBMAM, allows the user to create and maintain the Anthropometric Data Base. The Data Base contains regression data which are used by the interactive graphics program CBM05 to predict anthropometric surface dimensions needed to generate the link system of the man-model. It also contains survey data which define the means, standard deviations, and percentiles for every defined variable for a particular anthropometric survey. Each group of data, whether dealing with regression or survey information, is called an anthropometric member, and is referenced by its member name and type classification.

The program CBMAM allows the user to maintain the Data Base by adding, deleting, listing, etc., the member types through input control cards as shown in Figure 81.

These control cards may be placed in any order in the input stream of the program, with one exception. If the Data Base is initialized for the first time, the +INT control card must be the first data card. In the following paragraphs, the control cards format of the function is listed first. This is followed by the text which explains each keyword. Additional data formats, if any, are then described for each function.

A1	A4	A8	I4	I4	I4	I4	I4	I4	I4	A8	Optional Sequence Number
+	opr	member name	type	nvbl	ncmb	ndep	npct	regr name			
9	9	9 9 9 9 9 9 9	9 9 9 9 9 9 9	9 9 9 9 9 9 9	9 9 9 9 9 9 9	9 9 9 9 9 9 9	9 9 9 9 9 9 9	9 9 9 9 9 9 9			9 9 9 9 9 9 9 9
1	2	3 4 5 6 7 8 9	10 11 12 13 14 15 16 17	18 19 20 21 22 23 24 25	26 27 28 29 30 31 32 33	34 35 36 37 38 39 40 41	42 43 44 45 46 47 48 49	50 51 52 53 54 55 56 57	58 59 60 61 62 63 64 65	66 67 68 69 70 71 72	73 74 75 76 77 78 79 80

Figure 81. Program CBMAM Control Card Format.

#### 4.3.2.1 ADD ANTHROPOMETRIC MEMBER Function

+ADD membername type nvbl ncmb ndep  
regrname (followed by member definition)

The ADD ANTHROPOMETRIC MEMBER function, as defined by the +ADD control card and the member definition cards which follow, adds to the Anthropometric Data Base specified data under the name membername. The membername is an alphanumeric character string, whose length is limited to 16 characters. The type field distinguishes between the two types of members. A type value of "0" indicates that the member contains regression information, while a type value of "1" indicates that the member contains survey dimension data. The type value, as well as all other integer values supplied on the control card, must be right-justified within its field. The nvbl field defines the total number of variables described in member membername. The maximum number is 45. The ncmb field indicates the maximum number of combinations of independent mass and length variables. The maximum number is 50. The number of anthropometric variables needed to determine the internal link lengths is supplied in field ndep. The maximum number is 30. Fields, npct and regrname are used only when the type field value is 1. Npct contains the number of percentile values which will be supplied for every one of the nvbl variables. The maximum value for npct is 30. The regrname field refers to the type 0 membername which contains the appropriate regression information.

#### 4.3.2.2 TYPE 0 MEMBERS

An example of an +ADD control card for a type 0 member in the 1967 Survey is outlined in Figure 82. The name of the survey member is R67 USAF, and it contains a total of 17 variables, with 24 combinations of independent variables, and 121 combinations of dependent variables. An example of a

	+	ADD	R67	USAF	J	17	24	12	12	Ref. Fig. 81
1	WEIGHT					LB	1			
2	SITTING HEIGHT					IN		1		
3	EYE HGT/SITTING					IN		1		
4	ACROMION HGT/SIT					IN		1		
5	KNEE HGT/SITTING					IN		1		
6	OUTTOCK-KNEE LGTH					IN		1		
7	SHOULDR-LLS LGTH					IN		1		
8	ELBOW-OKIP LGTH					IN		1		
9	THUMB-TIP REACH					IN		1		
10	BIACROMIAL BRDTH					IN		1		

Ref. Fig. 84

Figure 82. Example of +ADD Control Card for Type 0 Member.

	+	ADD	67	USAF	I	17	24	12	25	R67	USAF	Ref. Fig. 81
1	2	3	51015202530354045505506060707580859095979859-									
1	WEIGHT					LB	175.60686	21.434704127581326313582140151408915153				
1552715856101561643716708169741724217513177921808418397187411913219591												
2018321076216022209422773												
2	SITTING HEIGHT					IN	36.682932	1.2501624	3394	3424	3444	3470
3502 3582 3600 3617 3633 3649 3665 3681 3698 3715 3733 3753 3773 3801												
3833 3880 3910 3931 3962												
3	EYE HGT/SITTING					IN	31.869176	1.1871142	2917	2950	2971	2998
3087 3106 3123 3138 3153 3168 3183 3198 3213 3229 3246 3265 3286 3311												
3343 3390 3421 3443 3478												
4	ACROMION HGT/SIT					IN	24.03821	1.123410	2142	2177	2224	2263
2310 2327 2343 2358 2373 2387 2401 2415 2430 2445 2461 2479 2499 2522												
2551 2594 2620 2639 2666												

Ref. Fig. 88

Figure 83. Example of +ADD Control Card for Type 1 Member.

+ADD control card for a type 1 member is outlined in Figure 83. The number of percentiles for each variable of survey member 67 USAF is 25, and the referenced regression type member is R67 USAF. Note that the values for nvbl, ncmb, and ndep are identical to the type 0 member R67 USAF, shown in Figure 82.

Figures 84, 85, and 86 shows the record formats used for type 0 members in the data base. The data provided in the format shown in Figure 84 define anthropometric variables used in the regression member. Columns 1-2 contain a sequence number for the variable, right-justified in the field. Columns 4-19 contain the 16-character name of the anthropometric variable. Columns 21-22 contain a two-character abbreviation for the default unit of measurement of the variable. Approved abbreviations are IN, CM, MM, LB, and KG for inches, centimeters, millimeters, pounds, and kilograms, respectively. A "1" punched in column 26, 30, or 34, indicates a mass related independent variable, a length related independent variable, or a dependent variable necessary to generate the link lengths respectively. A variable can either be independent or dependent, as in the case of sitting height, but it cannot pertain to both mass and length. If all three fields are blank, the data card is flagged to indicate an error. As each variable definition card is read in, the program checks the use of the variable and records its status.

The first outlined area of Figure 87 is an example of a Variable Definition Card. A "1" is punched in columns 30 and 34 to indicate that the Sitting Height is both an independent variable related to body segment length and a dependent variable.

Two types of record formats are used for combinations of mass and length related independent variables as shown in Figures 85 and 86. In Figure 85, the variable

I2 Vbl. Seq. No.	Al6 Variable Name	A2 Unit	I4 mass code	I4 lgth code	I4 dpndt code	Optional Sequence Number
999						
1 2 3 4 5 6 7 8 9 10 11 12 13 14 15 16 17 18 19 20						

Figure 84. Program CBMAM Regression Member Variable Definition Card.

I3 Mass Vbl. No.	Regr. values to predict length from other 3F10.5 length related vbl.			Regr. values to predict mass from length related vbl. 3F10.5			Optional Sequence Number
	B	C	Std. Error of Est.	B	C	Std. Error of Est.	
999							
1 2 3 4 5 6 7 8 9 10 11 12 13 14 15 16 17 18 19 20							

Figure 85. Program CBMAM Regression Member Simple Regression Coefficient Definition Card.

I3 Mass Vbl. No.	F10.5 slope for mass vbl. B1		F10.5 slope for lgth vbl. B2		F10.5 constant C		Optional Sequence Number
	I3 lgth vbl. no.	I3 dep vbl. no.	I3 vbl. no.	I3 vbl. no.	I3 no.	I3 no.	
999							
1 2 3 4 5 6 7 8 9 10 11 12 13 14 15 16 17 18 19 20							

Figure 86. Program CBMAM Regression Member Multiple Regression Coefficient Definition Card.

+ADD R67 USAF 0 17 24 12									
1	WEIGHT		LB	1		1			
2	SITTING HEIGHT		IN		1	1			
3	EYE HGT/SITTING		IN		1				
4	ACROMION HGT/SIT		IN			1			
5	KNEE HGT/SITTING		IN		1	1			
6	BUTTOCK-KNEE LGTH		IN		1	1			
7	SHOULDER-ELB LGTH		IN			1			
8	ELBOW-GRIP LGTH		IN		1				
9	THUMB-TIP REACH		IN		1				
10	BIACROMIAL BRDTH		IN			1			
11	BIDELTICD BRDTH		IN	1					
12	HIP BREADTH		IN			1			
13	HIP BREADTH/SITT		IN	1					
14	CHEST DEPTH		IN	1		1			
15	FCCT LENGTH		IN			1			
16	HAND LENGTH		IN			1			
17	ELBOW-WRIST LGTH		IN			1			
1	2		0.02609	32.05275	1.11101	7.84538	-114.20831	19.05910	
1	2	1	1.0	0.0	0.0				
1	2	2	0.0	1.0000000	0.0				
1	2	4		.731	-2.779522				
1	2	5		.404	7.133844				
1	2	6		.333	11.568506				
1	2	7		.247	5.090541				
1	2	10	0.0131732	0.1105000	9.69417				
1	2	12	0.0279173	0.0043000	8.87957				
1	2	14	0.0313031	-0.1005000	10.32958				
1	2	15	0.0069724	0.1248000	4.85468				
1	2	16		.117	3.232277				
1	2	17		.193	4.728337				
1	3		0.02287	27.89858	1.08116	7.45657	-64.02781	19.52158	
1	3	1	1.0	0.0	0.0				
1	3	2		0.979	5.484241				
1	3	4		0.737	0.55118				

Figure 87. Example of Regression, or Type 0 Member.

numbers, punched in columns 1-3 and 4-6 are obtained from columns 1-2 of the variable definition cards as shown in Figure 84. Columns 11-40 contain simple regression information necessary to predict the length related variable from the mass related variables. This information includes the slope and constant in the regression formula:

$$Y = bX + c \quad (2)$$

where:

b is the slope and  
c is the intercept.

It also contains the standard error of estimate associated with the equation. Columns 41-70 contain similar data to predict mass from the length variable.

The regression data used in the following examples are unpublished data provided by the USAF. These data contain the slope, intercept, and standard error in metric units. The coefficients are multiplied by appropriate factors to convert them to the English units specified on the Variable Definition Card. The regression equation to predict sitting height in inches from weight in pounds is:

$$\begin{aligned} \text{Estimated Sitting Height} &= 0.02669 \times \text{Actual Weight} + 32.05275 \\ &\quad (\text{Variable \#2}) \qquad \qquad \qquad (\text{Variable \#1}) \\ &\qquad \qquad \qquad \qquad \qquad \qquad \qquad \qquad \qquad (1) \end{aligned}$$

The standard error is 1.11161.

The equation to predict weight in pounds from sitting height in inches is:

$$\text{Estimated Weight} = 7.84538 \times \text{Actual Sitting Height} - 114.20831 \quad (2)$$

The standard error is 19.05910.

In Figure 87 (2), the "1" in column 3 identifies Weight as the mass related variable, and the "2" in column 6 identifies Sitting Height as the length related variable. The regression coefficients for equations (1) and (2) are punched in the remainder of the card.

The second record format is shown in Figure 86 and contains the multiple regression information necessary to predict each dependent variable from the particular combination of mass and length related variables. Columns 1-3 contain the independent mass variable number; columns 4-6 the independent length variable number; and columns 7-9 the dependent variable number. Each integer value must be right-justified. Columns 11-20 contain the slope associated with the mass variable value ( $b_1$ ); columns 21-30 the slope for the length variable value ( $b_2$ ); and columns 31-40 the constant of the equation ( $c$ ). The equation to predict the value  $y$  of a dependent variable is of the form:

$$Y = b_1X_1 + b_2X_2 + c \quad (3)$$

where:

$X_1$  is the value of mass related variable and  
 $X_2$  is the value of length related variable.

The data for this card are derived from the correlation matrices shown in Tables 8 and 9, and from the equations in Zeigen, et al, (1960). Since it is undesirable to have the length related variables to depend on the value chosen for the mass related variable, the multiple regression equations are replaced by single regression equations. As an example, the multiple regression equation to predict Knee Height/Sitting from Weight and Sitting Height is replaced by a single regression equation as follows:

$$\begin{aligned} \text{Knee Height/Sitting} &= 0.0 \times \text{Weight (Variable \#1)} \\ &+ 0.404000 \times \text{Sitting Height (Variable \#2)} \\ &+ 7.133844 \end{aligned}$$

The third outlined area of Figure 87 shows the data for this example. A "1" in column 3 identifies Weight as the mass variable; a "2" in column 6 identifies Sitting Height as the length variable; and a "5" in column 9 identifies Knee Height/Sitting as the dependent variable. The regression coefficients are punched in the remainder of the card.

The multiple regression equations are retained for predicting the mass-related variables. As an example, the multiple regression equation to predict Hip Breadth from Weight and Sitting Height is as follows:

$$\begin{aligned} \text{Hip Breadth} &= 0.0279173 \times \text{Weight} && \text{(Variable \#1)} \\ &+ 0.0043000 \times \text{Sitting Height} && \text{(Variable \#2)} \\ &+ 8.87957 \end{aligned}$$

The fourth outlined area of Figure 87 shows the data for this example. A "1" in column 3 identifies Weight as the mass variable; a "2" in column 6 identifies Sitting Height as the length variable; and a "12" in columns 8 and 9 identifies Hip Breadth as the dependent variable. The regression coefficients are punched in the remainder of the card.

If the number of multiple regression coefficient definition data cards is not equal to (ncmb x ndep) the member is not added to the Anthropometric Data Base.

#### 4.3.2.3 TYPE 1 MEMBERS

For type 1 members on the Data Base, the record formats are shown in Figures 88 and 89. The input data in the format shown in Figure 88 define the percentile names for which values are supplied in succeeding cards. Figure 90 shows the percentile names for the 1967 USAF Survey. The 25 percentile values available for this survey include the 1st, 2nd, 3rd, 5th, and are punched in two-digit integer fields, right-justified within the area. The number of percentiles supplied must be equal to the value in the npct field of the +ADD (type 1) control card, otherwise an error message is printed and the member is not added. Note that the maximum number of percentiles allowed is 30.

Figure 89 shows the format used in assigning dimensional values to the variables. The variable number in integer format is in columns 1-2 while columns 4-19 contain the 16-character variable name. Columns 21-22 contain the two character abbreviation for the default unit of measurement. At present the default or standard unit for weight is pounds, and the standard unit for all other measurements is inches. For each variable number, the variable name and unit of measurement must correspond with the same fields in the reference type 0 or regression member. Columns 23-32 contain the overall mean for the named variable expressed in the default unit of measurement. Columns 33-42 contain the standard deviation. Columns 43-72 of this data card and columns 1-70 of additional cards necessary to input data contain the values for each of the percentiles named. If the number of percentile values does not correspond to the value of npct, an error



+ADD	67	USAF	1	17	24	12	25	R67	USAF	→	Ref. Fig. 81		
1	2	3	5101520253035404550550065707580859095979899	→	Ref. Fig. 80								
1	WEIGHT	L8	173.60686	21.434704127581326313582140151468915153	→	Ref. Fig. 89							
15	2715850161501043710708169741724217513177921608418397187411913219591	2018321075216022209422773											
2	SITTING HEIGHT	IN	36.685932	1.2501624	2394	3424	5444	3470	3511	3539			
3002	3002	3000	3017	3000	3077	3005	3001	3090	3110	3133	3155	3801	
3833	3880	3910	3931	3962									
3	EYE HGT/SITTING	IN	31.869176	1.1671142	2917	2950	2971	2998	3038	3065			
3087	3106	3123	3138	3153	3168	3183	3198	3213	3229	3246	3265	3285	3311
3343	3390	3421	3443	3478									
4	ACROMION HGT/SIT	IN	24.03821	1.123410	2142	2177	2197	2224	2263	2289			
2310	2327	2343	2358	2373	2387	2401	2415	2430	2445	2461	2479	2499	2522
2551	2594	2620	2639	2666									
5	KNEE HGT/SITTING	IN	21.95673	.98041	1973	1998	2015	2037	2071	2095			
2113	2129	2143	2157	2169	2182	2194	2206	2219	2231	2245	2260	2277	2296
2322	2360	2386	2405	2436									
6	BUTTUCK-KNEE LGTH	IN	23.78431	1.06204	2138	2165	2183	2207	2244	2269			
2289	2306	2322	2336	2350	2363	2376	2389	2402	2416	2431	2447	2465	2480
2514	2557	2587	2610	2648									
7	SHOULDR-ELB LGTH	IN	14.15302	.674011	1265	1281	1291	1306	1329	1345			

Figure 90 . Example of Survey, or Type 1, Member.

condition occurs and the member is not added to the Data Base. The period in the fields in Figures 88 and 89 indicates the standard or default location of the decimal point in real number format.

The dimension data needed in this card are also obtained from the Summary Statistics of the 1967 Survey (Churchill et al, 1976). A sample set of the data for Weight is shown in Figure 80. The mean value of Weight, 173.60686 lbs, the standard deviation, 21.434704, and the weights associated with the first six percentiles, namely the 1st, 2nd, 3rd, 5th, 10th, and 15th are punched on the third card shown in Figure 90. The weight values for the percentiles ranging from 20th to 85th, and from 90th to 99th, are punched in the last card. It is essential that users enter a type 0 member into the Data Base prior to adding the associated type 1 member, since the type 1 member references the type 0 member.

#### 4.3.2.4 CHECK ANTHROPOMETRIC MEMBER Function

```
+CHK membername type nvbl ncmb, ndep  
npct regr name
```

The CHECK ANTHROPOMETRIC MEMBER function operates the same way the ADD ANTHROPOMETRIC MEMBER function. However, the member is not added but the data are checked for errors.

#### 4.3.2.5 DELETE ANTHROPOMETRIC MEMBER Function

```
+DEL membername type
```

The DELETE ANTHROPOMETRIC MEMBER function removes the specified member from the Data Base, but does not make the space occupied by the member available for reuse. The +CMP function must be used to accomplish this.

#### 4.3.2.6 COMPRESS ANTHROPOMETRIC DATA BASE Function

+CMP

The COMPRESS ANTHROPOMETRIC DATA BASE function makes space available for storing anthropometric data by compressing used space together and maximizing the amount of continuous unused space on the Data Base. The intermediate blocks of unused space are created by the DELETE ANTHROPOMETRIC MEMBER function. The greater the activity of the Anthropometric Data Base (ie., +ADD's and +DEL's), the more often it becomes necessary to use this +CMP function. If the message "CBM310A INSUFFICIENT SPACE REMAINING TO ADD MEMBER membername" appears while adding a member, it becomes necessary to use the +CMP function. If the +ADD function gives the CBM310A message immediately following the +CMP function, the Data Base is full and no new members can be added until an existing member is deleted from the Data Base.

#### 4.3.2.7 DUMP ANTHROPOMETRIC MEMBER Function

+DMP membername type  
+DMP

The DUMP ANTHROPOMETRIC MEMBER function prints the contents of the anthropometric member membername of specified type, or prints the complete Anthropometric Data Base if no member name is given on the control card. This function is used primarily by system programmers to check the contents of the file.

#### 4.3.2.8 END PROGRAM Function

+END

The END PROGRAM function control card terminates execution of the program CBMAM and returns control to the operating system.

#### 4.3.2.9 INITIALIZE ANTHROPOMETRIC DATA BASE Function

+INT

The INITIALIZE ANTHROPOMETRIC DATA BASE function initializes an Anthropometric Data Base or resets an existing Anthropometric Data Base to its original unused state. All members residing on the Data Base before invoking this function are purged and the entire space is made available for new members. However, the primary purpose of this function is to establish an Anthropometric Data Base.

#### 4.3.2.10 PUNCH ANTHROPOMETRIC MEMBER Function

+PCH membername type

The PUNCH ANTHROPOMETRIC MEMBER function punches a copy of the specified member in the same format as the ADD ANTHROPOMETRIC MEMBER function input data for the specified type onto computer cards. If the user specifies a member name that does not exist on the directory, all the member names on the Data Base directory are printed out. This function does not add or remove any member from the Data Base.

#### 4.3.2.11 PRINT ANTHROPOMETRIC MEMBER Function

+PRT membername type  
+PRT

The PRINT ANTHROPOMETRIC MEMBER function prints the contents of the specified member, membername, of type, type, in a format similar to that used in the ADD ANTHROPOMETRIC MEMBER function. If no name is specified, or if a name that is not in the Data Base directory is specified, names of all members in the Data Base directory, the number of records for each member, their types, and any additional data supplied on the +ADD control card when the members were added to the Data Base are printed.

### 4.3.3 Submitting a Processing Request

The set of JCL used at HESS facility to run the program CBMAM is shown in Figure 91. Use of the //FT02F001 DD card as shown in Figure 91 assumes that the space for the Data Base has already been allocated and catalogued. If for some reason this condition is not met, the //FT02F001 DD card in Figure 91 should be replaced by the card sequence (3 cards) shown in Figure 92. The job is run with this replacement series once to allocate space for the data set (file) on disk, and to catalogue the file. Thereafter the simplified //FT02F001 DD card shown in Figure 91 is used to maintain the Data Base.

If the file has just been created, or if the user wants to reinitialize the file, the +INT control function is used before any other control function.

The last control card read into the program should be the +END control card.

### 4.3.4 Output Data Interpretation

The program CBMAM generates output to the card punch, to the disk file, or to the printer depending on the function specified on the control card. The formats for the printed output are discussed in this section. Punched records use the same format as the input data records discussed in Paragraph 4.3.2.

Five basic types of formats are used by CBMAM when data are written on the printer. These format types, their use, and sample outputs are presented in the following paragraphs. Each type begins with the same heading, listing the program name, CBMAM, the date and time of the program execution, and a page number.

```

UUUU1000
UU001100
00001200
00001300
00001400
00001500
00001600
00001700
00001800

```

```

//CBMAM      JOB  HESS
//JCLLIB    DD  DSN=COMBIMAN.LUADLIB,DISP=SHR
//CBMAM      EXEC  PGM=CBMAM
//FT02F001  DD  DSN=COMBIMAN.ANTHDATA,DISP=SHR
//FT05F001  DD  DDNAME=SYSIN
//FT06F001  DD  SYSUUT=A
//FT07F001  DD  SYSUUT=B
//SYSUDUMP  DD  SYSUUT=A
//SYSIN     DD  *

```

```

CBMAM FUNCTION CONTROL CARDS AND
MEMBER DEFINITION DATA

```

```

/*
//          00001900

```

Figure 91. Job Control Cards to Execute CBMAM.

```

//FT02F001  DD  DSN=COMBIMAN.ANTHDATA,UNIT=DISK,DISP=(NEW,CATLG),
//          VOL=SER=DISK01,SPACE=(248,2000),
//          OCB=(BLKSIZE=248,LRECL=248,RECFM=FB)

```

```

00001300
00001410
00001320

```

Figure 92. FT02 DD Card to Allocate Space for COMBIMAN.ANTHDATA and Execute CBMAM.

The first type of output is generated by the INITIALIZE, PUNCH, COMPRESS, DELETE, and END functions. The output indicates the beginning and end of processing associated with the specified function. For the COMPRESS function, additional messages which indicate that a particular member is or is not moved in the process of compressing used space are printed. An example of this format for the COMPRESS function is shown in Figure 93.

The second type of output is generated by the PRINT or PUNCH functions when the +PRT or +PCH control cards are supplied with a blank membername field. This causes the program to list the index of the Data Base, which contains the location and type of each member. This information is printed in the following format:

```
nn.) membername, EXTENT = (n1, n2), TYPE = tt,  
  nv VARIABLES, nc COMB OF INDEP, nd DEPENDENT,  
  np PERCENTILES, r-membername REFERENCED SURVEY.
```

where:

nn	is the record number of its identification record within the directory.
n1	is the location of the first record of the data which defines this member.
n2	is the location of the last record of the data which defines this member.
tt	is the type code (0 or 1).
nv	is the total number of anthropometric variables defined for the member.
nc	is the number of combination of independent variables.
nd	is the number of dependent variables.
np	is the number of percentiles. Note: np=0 if tt=0.
r-membername	is the name of the referenced regression member. Note: r-membername is blank if tt=0.

```
0013001 +CMP R67 USAF
0013351 R67 USAF WAS IN PLACE.
0013351 67 USAF WAS IN PLACE.
0013361 COMPRESS FINISHED.
0013991 PROGRAM END.
```

Figure 93. A Sample Output of the +CMP Function.

This information was originally supplied to the Data Base on the +ADD control card. A sample output of the PRINT function is shown in Figure 94.

The third type of output is generated by the DUMP ANTHROPOMETRIC DATA BASE function. This function is used primarily by systems programmers to locate causes of I/O (Input/Output) errors on the Data Base. For the member specified on the +DMP Control Card, a directory or index information is printed, using the output format previously described for the +PRT control card. Each record associated with the member is then printed in the following format:

```

RECORD nnn + = + (record in EBCDIC)           + = +
      + = + (record in hexadecimal)           + = +
      + = + (remainder of record in hexadecimal) + = +

```

where nnn is the location of the record in the Data Base. The record is printed in EBCDIC using a 25A4 format and in hexadecimal using a 10Z8 format. An example of the DUMP function printout is shown in Figure 95.

The fourth output format is used by the CHECK, ADD, and PRINT functions when a type 0, or regression member is specified. The program CBMAM reads the control card and checks it for errors, and the information obtained from the control card is reformatted and written out to the printer. Following the control card information, each Variable Definition Card is printed. The format used to print the Variable Definition Card is as follows:

```

nn.) variablename, INDEP VBLs (MASS=ns, LENGTH=ns), DEP
      VBL=ns, UNIT OF MEASUREMENT=uu

```

```
CBM3001 +PRT
0
20.) 67 USAF , EXTENT=( 63, 80), TYPE= 1, 17 VARIABLES, 24 CUMB OF INDEP, 12 DEPENDENT, 25 PERCENTILES,
      R67 USAF REFERENCED SURVEY.
21.) R67 USAF, EXTENT=( 22, 62), TYPE= 0, 17 VARIABLES, 24 CUMB OF INDEP, 12 DEPENDENT, 0 PERCENTILES,
      REFERENCED SURVEY.
```

Figure 94. A Sample Output of the +PRT Function.



where:

nn	is the variable number
variablename	is the 16 character name of the variable
ns	0 means NO; 1 means Yes
uu	is the unit of measurement assigned to the variable: IN, CM, MM, LB, or KG.

After the variable definition data, the regression data for each combination of independent variables are printed. The format is shown in Figure 96. The terms are defined as follows:

n1	is the variable number for the mass-related variable
mass name	is the variable name for the mass-related variable
n2	is the variable number for the length-related variable
length name	is the variable name for the length-related variable
bb.bbb <sub>1</sub> ,bb.bbb <sub>2</sub>	is the slope used to predict (1) length variable from mass variable, and (2) mass variable from length variable
cc.ccc <sub>1</sub> ,cc.ccc <sub>2</sub>	is the constant used to predict (1) length variable from mass variable, and (2) mass variable from length variable
ss.sss <sub>1</sub> ,ss.sss <sub>2</sub>	is the standard error of the estimate of the equations
nd <sub>1</sub> - nd <sub>ndep</sub>	are the variable numbers for the dependent variables
depname <sub>1</sub> - depname <sub>ndep</sub>	are the variable names for the dependent variables
bb.bbb <sub>i</sub> <sub>1</sub> - bb.bbb <sub>i</sub> <sub>ndep</sub>	is the slope for the mass variable when predicting dependent variable <sub>i</sub> , where i=1, ndep

INDEPENDENT VARIABLES (MASS & LENGTH)	DEPENDENT VARIABLE	REGRESSION COEFFICIENTS (B1, B2, CNST)
<u>n1</u> <u>mass name</u>	SIMPLE REGR (B1, CNST, SE) -	LENGTH FROM MASS <u>bb.bbb</u> <sub>1</sub> <u>cc.ccc</u> <sub>1</sub> <u>ss.sss</u> <sub>1</sub>
<u>n2</u> <u>length name</u>		MASS FROM LENGTH <u>bb.bbb</u> <sub>2</sub> <u>cc.ccc</u> <sub>2</sub> <u>ss.sss</u> <sub>2</sub>
<u>nd</u> <sub>1</sub>	<u>dep vbl name</u> <sub>1</sub>	<u>bb.bbb</u> <sub>1</sub> <sup>1</sup> <u>bb.bbb</u> <sub>1</sub> <sup>2</sup> <u>cc.cccc</u> <sub>1</sub>
:	:	:
:	:	:
<u>nd</u> <sub>ndep</sub>	<u>dep vbl name</u> <sub>ndep</sub>	<u>bb.bbb</u> <sub>1</sub> <sup>1</sup> <u>bb.bbb</u> <sub>2</sub> <sup>2</sup> <u>cc.cccc</u> <sub>ndep</sub>

Figure 96. Output Format Used for Type 0 Regression Data.

bb.bbbbb <sub>i</sub> -	is the slope for the length variable
bb.bbbbb <sub>ndep</sub>	when predicting dependent variable <sub>i</sub> , where i=1, ndep
cc.ccccc <sub>1</sub> -	is the constant for the multiple
cc.ccccc <sub>ndep</sub>	regression equation to predict dependent variable <sub>i</sub> , where i=1, ndep.

An example of the output in the fourth format for the +ADD control card is shown in Figure 97 and 98.

The fifth output format is also used by the CHECK, ADD and PRINT functions, but only when the type code is 1, indicating a survey member. The program CBMAM reads the control card and checks it for errors, and reformats and prints the information on the card relevant to the number of records written to the Data Base. Following the control card information, the percentile names (such as 1, 2, 3, 50, 95, etc.) for the member are printed as part of a subheading. A maximum of 10 percentile names are printed on one line. The survey data are then printed in the following format:

```

nn.) variablename uu mmm.mm ss.sss ppp.pp1 ... ppp.pp10
      ppp.pp11 ... ppp.pp20
      ppp.pp21 ... ppp.ppnpct

```

where

nn	is the variable number
variablename	is the name of the anthropometric variable
uu	is the specified unit of measurement for the variable
mmm.mm	is the mean value for the variable
ss.sss	is the standard deviation for the variable
ppp.pp1- ppp.ppnpct	are the percentile values associated with the percentile names for the anthropometric variables

An example of this fifth format is shown in Figure 99.

COM314M 4000 17 24 12 C  
 COM3131 MEMBER 167 USAF JS TYPE 0 AND CONTAINS 17 ANTHROPOMETRIC VARIABLE NAMES.  
 COM3141 MEMBER ALSO CONTAINS 24 ADDITIONAL RECORDS, EACH CONTAINING THE REGRESSION COEFFICIENTS FOR 12 DEPENDENT VARIABLES.

INDEPENDENT VARIABLES (MASS & LENGTH)	DEPENDENT VARIABLE	REGRESSION COEFFICIENTS (B1, B2, CNST)
1 WEIGHT	1 WEIGHT	0.027 32.053 1.112
2 SITTING HEIGHT	2 SITTING HEIGHT	7.845-114.208 19.059
4 ALCRUMION HGT/SIT	4 ALCRUMION HGT/SIT	0.0 0.0
5 KNEE HGT/SITTING	5 KNEE HGT/SITTING	0.0 0.0
6 BUTTUCK-KNE LGTH	6 BUTTUCK-KNE LGTH	0.0 0.0
7 SHOULDR-ELB LGTH	7 SHOULDR-ELB LGTH	0.0 0.0
10 BIACRUMIAL BRDTH	10 BIACRUMIAL BRDTH	0.01317 0.11050 9.69417
12 HIP BRDADTH	12 HIP BRDADTH	0.02792 0.00430 8.87957
14 CHEST DLPTH	14 CHEST DLPTH	0.03130 -0.16650 10.32958
15 FOOT LENGTH	15 FOOT LENGTH	0.00697 0.12480 4.85468
16 HAND LENGTH	16 HAND LENGTH	0.0 0.11700 3.23228
17 ELBOW-WRIST LGTH	17 ELBOW-WRIST LGTH	0.0 0.19300 4.72834

Figure 97. A Sample Output of the +ADD Function for Type 1 Member.

1 WEIGHT	3 EYE HGT/SITTING	SIMPLE REGR (BL, CNST, SE)	LENGTH FROM MASS	0.023	27.899	1.081
1 WEIGHT	5 KNEE HGT/SITTING	SIMPLE REGR (BL, CNST, SE)	LENGTH FROM MASS	7.457	-64.028	19.522
1 WEIGHT	1 WEIGHT	1.00000	0.0	0.0	0.0	0.0
2 SITTING HEIGHT	2 SITTING HEIGHT	0.0	0.97900	5.48424		
4 ACROMION HGT/SIT	4 ACROMION HGT/SIT	0.0	0.73700	0.55118		
5 KNEE HGT/SITTING	5 KNEE HGT/SITTING	0.0	0.40300	9.11415		
6 BUTTUCK-KNE LGTH	6 BUTTUCK-KNE LGTH	0.0	0.34900	12.66139		
7 SHOULDR-ELB LGTH	7 SHOULDR-ELB LGTH	0.0	0.26000	5.86613		
10 BIACROMIAL BRDTH	10 BIACROMIAL BRDTH	0.01416	0.08570	10.84526		
12 HIP BREADTH	12 HIP BREADTH	0.02782	0.00930	8.75802		
14 CHEST DEPTH	14 CHEST DEPTH	0.03049	-0.15870	9.41976		
15 FOOT LENGTH	15 FOOT LENGTH	0.00752	0.12150	5.46532		
16 HAND LENGTH	16 HAND LENGTH	0.0	0.11300	3.92125		
17 ELBOW-WRIST LGTH	17 ELBOW-WRIST LGTH	0.0	0.17300	6.29526		
5 KNEE HGT/SITTING	5 KNEE HGT/SITTING	0.0	0.17300	6.29526		
1 WEIGHT	1 WEIGHT	1.00000	0.0	0.025	17.666	0.827
2 SITTING HEIGHT	2 SITTING HEIGHT	0.0	0.65600	11.762	-84.611	18.054
4 ACROMION HGT/SIT	4 ACROMION HGT/SIT	0.0	0.51000	22.28342		
5 KNEE HGT/SITTING	5 KNEE HGT/SITTING	0.0	1.00000	12.83855		
6 BUTTUCK-KNE LGTH	6 BUTTUCK-KNE LGTH	0.0	0.85100	5.09842		
7 SHOULDR-ELB LGTH	7 SHOULDR-ELB LGTH	0.0	0.51600	2.82283		
10 BIACROMIAL BRDTH	10 BIACROMIAL BRDTH	0.01256	0.14420	10.68774		
12 HIP BREADTH	12 HIP BREADTH	0.02823	-0.00810	9.16118		
14 CHEST DEPTH	14 CHEST DEPTH	0.03019	-0.13470	7.37230		
15 FOOT LENGTH	15 FOOT LENGTH	0.00303	0.29470	3.64651		
16 HAND LENGTH	16 HAND LENGTH	0.0	0.21500	2.80314		
17 ELBOW-WRIST LGTH	17 ELBOW-WRIST LGTH	0.0	0.44300	2.08267		
6 BUTTUCK-KNE LGTH	6 BUTTUCK-KNE LGTH	0.0	0.44300	2.08267		
1 WEIGHT	1 WEIGHT	1.00000	0.0	0.032	18.299	0.821
2 SITTING HEIGHT	2 SITTING HEIGHT	0.0	0.46000	12.813	-131.085	16.540
4 ACROMION HGT/SIT	4 ACROMION HGT/SIT	0.0	0.35800	25.74403		
5 KNEE HGT/SITTING	5 KNEE HGT/SITTING	0.0	0.72500	15.52359		
6 BUTTUCK-KNE LGTH	6 BUTTUCK-KNE LGTH	0.0	1.00000	4.71259		
7 SHOULDR-ELB LGTH	7 SHOULDR-ELB LGTH	0.0	0.44200	0.0		
10 BIACROMIAL BRDTH	10 BIACROMIAL BRDTH	0.01581	0.00570	3.64172		
12 HIP BREADTH	12 HIP BREADTH	0.02673	0.00570	13.06010		
14 CHEST DEPTH	14 CHEST DEPTH	0.02938	0.04120	8.26378		
15 FOOT LENGTH	15 FOOT LENGTH	0.00338	-0.07950	6.44568		
16 HAND LENGTH	16 HAND LENGTH	0.0	0.21920	4.84350		
17 ELBOW-WRIST LGTH	17 ELBOW-WRIST LGTH	0.0	0.16500	3.59642		
6 BUTTUCK-KNE LGTH	6 BUTTUCK-KNE LGTH	0.0	0.32700	4.03149		

Figure 98. A Sample Output of the +ADD Function for Type 1 Member.

CS43001 ADDU 67 USAF 1 17 24 12 25 R67 USAF  
 CS43141 PLMELR 67 USAF 15 TYPE 1 AND CONTAINS 17 ANTHROPOMETRIC VARIABLE NAMES.

NO.	VARIABLE NAME	UNIT	MEAN	STDV	PERCENTILES									
					1	2	3	5	10	15	20	25	30	35
1.1	WEIGHT	LB	173.61	21.435	40	45	50	55	60	65	70	75	80	85
2.1	SITTING HEIGHT	IN	36.65	1.250	90	95	97	98	99	151.53	155.27	158.56	161.56	164.37
3.1	LYE HGT/SITTING	IN	31.87	1.187	127.58	132.63	135.82	140.15	146.89	151.53	155.27	158.56	161.56	164.37
4.1	ACROACHEN HGT/SIT	IN	24.04	1.123	167.08	169.74	172.42	175.13	177.92	180.84	183.97	187.41	191.32	195.91
5.1	KNEE HGT/SITTING	IN	21.96	0.980	201.83	210.76	216.62	220.94	227.73	35.39	35.62	35.82	36.00	36.17
6.1	OUTTUCK-KNEE LGTH	IN	23.78	1.062	33.94	34.24	34.44	34.70	35.11	37.15	37.33	37.53	37.75	38.01
7.1	SHOULDER-ELB LGTH	IN	14.15	0.674	36.34	36.49	36.65	36.81	36.98	38.33	38.80	39.10	39.62	39.87
8.1	ELBOW-GRIP LGTH	IN	13.86	0.636	29.17	29.50	29.71	29.98	30.38	30.65	30.87	31.06	31.23	31.38
9.1	THUMB-TIP REACH	IN	31.62	1.565	31.53	31.68	31.83	31.98	32.13	32.29	32.46	32.65	32.86	33.11
10.1	BIACROMIAL BRDTH	IN	16.03	0.764	33.43	33.90	34.21	34.43	34.78	22.89	23.10	23.27	23.43	23.58
11.1	BIACROMIAL BRDTH	IN	18.95	1.008	21.42	21.77	21.97	22.24	22.63	22.89	23.10	23.27	23.43	23.58
12.1	HIP BRDTH	IN	13.88	0.742	23.73	23.87	24.01	24.15	24.30	24.45	24.61	24.79	24.99	25.22
13.1	HIP BRDTH/SIT	IN	14.68	0.906	25.51	25.94	26.20	26.39	26.66	20.95	21.13	21.29	21.43	21.57
14.1	CHEST BRDTH	IN	9.65	0.758	19.73	19.98	20.15	20.37	20.71	20.95	21.13	21.29	21.43	21.57
15.1	FOOT LENGTH	IN	10.64	0.468	21.69	21.82	21.94	22.06	22.19	22.31	22.45	22.60	22.77	22.96

Figure 99. A Sample Output of the +ADD Function for Type 0 Member.

#### 4.4 PROGRAM MESSAGES INCLUDING ERROR CORRECTION

The program CBMAM prints out both information and action related messages. The message format is as follows:

CBM3nni                    message text

where:

nn                    is the message number  
i                    identifies the action code (I=informa-  
                    tional, A=action to be performed), and  
message text           is the text of the message.

Unless otherwise noted, all messages are issued by the routine CBMAM.

CBM300I    Control card image (e.g. +ADD, +PRT, etc.)  
Reason:        The user submitted a control card.  
System Action: Continues processing.  
User Action:    None.

CBM301A    Operation - UNKNOWN OPERATION.  
Reason:        The operation on the control card  
                 (shown in the previous CBM300I Mes-  
                 sage) is unknown.  
System Action: The control card is ignored.  
User Action:    Correct card, using a valid opera-  
                 tion, and resubmit.

CBM302I    INITIALIZED.  
Reason:        The user requested to initialize the  
                 Anthropometric data base using the  
                 INITIALIZE ANTHROPOMETRIC DATA BASE  
                 Function (+INT).  
System Action: The Data Base is initialized.  
User Action:    None.

CBM303A    NO NAME GIVEN; operation IGNORED.  
Reason:        The operation specified on the con-  
                 trol card requires a membername; but  
                 no name was supplied.  
System Action: The control card and subsequent  
                 data, if any, are ignored.  
User Action:    Correct the card, adding the appro-  
                 priate additional information as  
                 required in the definition of the  
                 specific operation, and resubmit.

CBM304A TYPE SPECIFICATION INVALID FOR MEMBER membername.  
Reason: An invalid type code, that is, a type code other than 0 or 1, was given for the specified member.  
System Action: Control card, and any subsequent data, are ignored.  
User Action: Correct code and resubmit.

CBM305A NUMBER OF ANTHROPOMETRIC DIMENSIONS INVALID FOR MEMBER membername.  
Reason: The number of anthropometric dimensions specified for the given member on either the +ADD or +CHK control card was either less than one or greater than 45.  
System Action: Control card and any subsequent data are ignored.  
User Action: Correct value and resubmit.

CBM306A NUMBER OF COMBINATIONS OF INDEPENDENT VARIABLES INVALID FOR MEMBER membername  
Reason: The number of combinations of independent variables (the product of the number of mass related variables and the number of length related variables) for the +ADD or +CHK control card is less than one or greater than 50, for the specified member.  
System Action: The control card and any subsequent data are ignored.  
User Action: Correct the card and resubmit.

CBM307A NUMBER OF DEPENDENT VARIABLES INVALID FOR MEMBER membername  
Reason: The number of dependent variables specified on the +ADD or +CHK control card was less than one or greater than 30 for the indicated member.  
System Action: The control card and any subsequent data are ignored.  
User Action: Correct the card and resubmit.

CBM308A NUMBER OF PERCENTILES INVALID FOR MEMBER membername  
Reason: The number of percentiles specified on the +ADD or +CHK control card was less than one or greater than 30 for the indicated member.  
System Action: The control card and subsequent data are ignored.  
User Action: Correct the number and resubmit.

CBM309A      ILLEGAL CONTROL CARD FOR MEMBER membername DUE TO nn  
 ERRORS.  
 Reason:            Control card format invalid. The  
                      system found nn errors.  
 System Action:   Control card and subsequent data  
                      cards are ignored.  
 User Action:       Correct the card and resubmit.

CBM310A      INSUFFICIENT SPACE REMAINING TO ADD MEMBER  
membername.  
 Reason:            The Data Base does not have suffi-  
                      cient continuous space to add the  
                      specified member.  
 System Action:   The member is not added to the data  
                      base.  
 User Action:       Run the program CBMAM with the +CMP  
                      control card, followed by the re-  
                      quest to add the specified member.  
                      If the CBM310A message reappears,  
                      members will have to be deleted  
                      (using the +DEL function) before  
                      adding new member.

CBM311A      DIRECTORY IS FULL, CANNOT ADD membername.  
 Reason:            The Data Base directory, which con-  
                      tains the location of each member  
                      within the file, can hold a maximum  
                      of 20 entries.  
 System Action:   The member is not added to the Data  
                      Base.  
 User Action:       Delete a member and add the new  
                      member.

CBM312A      MEMBER membername IS NOT FOUND IN THE DIRECTORY.  
 Reason:            The type 0 member membername which  
                      was referenced by the type 1 member  
                      is not in the directory.  
 System Action:   The control card and data are ig-  
                      nored.  
 User Action:       Check that the type 0 member was  
                      specified.

CBM313I      MEMBER, membername IS TYPE tt AND CONTAINS nn  
 ANTHROPOMETRIC VARIABLE NAMES.  
 Reason:            The +ADD or +CHK control card has  
                      been read in for the specified mem-  
                      ber, and the type field and the  
                      number of variables have been ac-  
                      cepted.  
 System Action:   Program continues execution.  
 User Action:       None.

CBM314I MEMBER ALSO CONTAINS nn ADDITIONAL RECORDS, EACH CONTAINING THE REGRESSION COEFFICIENTS FOR mm DEPENDENT VARIABLES.  
Reason: Message is printed for +ADD or +CHK control card for type 0 members. It provides information on the number of additional records associated with the previously specified member.  
System Action: Program continues execution.  
User Action: None.

CBM315A VARIABLE variablename1 HAS THE SAME NUMBER AS VARIABLE variablename2.  
Reason: Each variable entered as part of a type 0 or type 1 member must have a unique number.  
System Action: Record which defines variablename1 is flagged as containing an error. Member is not added.  
User Action: Correct the number and resubmit.

CBM316A variable name USED IN VARIABLES n1 AND n2.  
Reason: Each variable number must have a unique variable name.  
System Action: Record which contains variable number n2 is flagged as containing an error. Member is not added.  
User Action: Correct record and resubmit.

CBM317A variable name IS NEITHER DEPENDENT OR INDEPENDENT.  
Reason: An anthropometric variable must be defined as either dependent, that is one necessary for the creation of the link system of the model, or independent, that is a variable highly correlated to body segment mass or body segment length. This variable has not been flagged as either.  
System Action: The record is flagged as containing an error, and the member is not added to the data base.  
User Action: Punch a "1" in either column 16, 30, or 34, depending on the type of variable and resubmit.

CBM318A     variablename IS INDEPENDENT VARIABLE FOR BOTH MASS  
AND LENGTH.  
Reason:             An anthropometric variable may be an  
                      independent variable correlated to  
                      either mass or length, but not to  
                      both.  
System Action:     The record is flagged as containing  
                      an error, and the member is not  
                      added to the Data Base.  
User Action:        Delete the entry "1" from either  
                      column 26 or 30 and resubmit.

CBM319A     MEMBER membername CONTAINS TOO MANY INDEPENDENT  
VARIABLES.  
Reason:             The number of combinations of  
                      independent variables (number of  
                      mass variables x number of length  
                      variables) encountered must be equal  
                      to the number of combinations speci-  
                      fied on the +ADD or +CHK control  
                      card.  
System Action:     Member is not added to Data Base.  
User Action:        Verify the totals, make the appro-  
                      priate corrections, and resubmit.

CBM320A     MEMBER membername CONTAINS TOO MANY DEPENDENT  
VARIABLES.  
Reason:             The number of dependent variables  
                      encountered must be equal to the  
                      number of dependent variables speci-  
                      fied on the +ADD or +CHK control  
                      card.  
System Action:     Member is not added to the Data Base.  
User Action:        Verify the total, make appropriate  
                      corrections, and resubmit.

CBM321A     UNIT OF MEASUREMENT, uu FOR VARIABLE variablename IS  
NOT PERMISSIBLE.  
Reason:             Valid units of measurement are IN,  
                      CM, MM, LB, and KG.  
System Action:     The record is flagged and the member  
                      is not added to the Data Base.  
User Action:        Supply a valid unit of measurement,  
                      and resubmit.

CBM322A     DATA CARD IMAGE multiple regression coefficient card  
image OUT OF SEQUENCE.  
Reason:             For each combination of independent  
                      variables, a total of NDEP+1 records  
                      must be supplied, each beginning  
                      with the same two variable numbers  
                      specifying the mass and length vari-  
                      able.  
System Action:     The record is flagged and the member  
                      is not added to the Data Base.  
User Action:        Correct the error and resubmit.

CBM323A VARIABLE variable name IS NOT AN INDEPENDENT VARIABLE PERTAINING TO MASS.  
Reason: The variable number supplied in column 1-3 of the regression data cards should correspond to a variable name defined as a mass related independent variable on one of the anthropometric variable definition cards. (See Figure 89)  
System Action: The record is flagged and the member is not added to the Data Base.  
User Action: Correct the error and resubmit.

CBM324A VARIABLE variablename IS NOT AN INDEPENDENT VARIABLE PERTAINING TO LENGTH.  
Reason: The variable number supplied in column 4-6 of the regression definition data cards should correspond to a variable name defined as a length related independent variable on one of the anthropometric variable definition cards. (See Figure 89)  
System Action: The record is flagged and the member is not added to the Data Base.  
User Action: Correct the error and resubmit.

CBM325A VARIABLE variablename IS NOT A DEPENDENT VARIABLE.  
Reason: The variable number supplied in columns 7-9 of the multiple regression data definition cards should correspond to a variable name defined as a dependent variable on one of the anthropometric variable definition cards. (See Figure 89)  
System Action: The record is flagged and the member is not added to the Data Base.  
User Action: Correct the error and resubmit.

CBM326A VARIABLE nn OUT OF SEQUENCE.  
Reason: For a type 1 member definition, the survey definition cards must contain the variable numbers in ascending order.  
System Action: The record is flagged and the member is not added to the Data Base.  
User Action: Make necessary corrections and resubmit.

CBM327A      variablename IN MEMBER survey membername DOES NOT  
CORRESPOND TO VARIABLE nn IN regression membername.  
Reason:            The variable names and numbers in  
the type 1 member survey membername  
should correspond exactly to the  
names and numbers in the referenced  
type 0 member regression membername.  
System Action:    The record in the type 1 member  
definition is flagged and the member  
is not added to the data base.  
User Action:        Verify the survey definition vari-  
able number and name against the  
regression or type 0 member, make  
necessary corrections, and resubmit.

CBM328A      ANTHROPOMETRIC DIMENSION LT OR EQ TO ZERO.  
Reason:            Dimensions supplied in the survey  
member definition cards must be  
positive real numbers.  
System Action:    The record is flagged and the member  
is not added.  
User Action:        Correct and resubmit.

CBM329I      MEMBER regression membername, WITH nn ANTHROPOMETRIC  
VARIABLES AND nn1 X nn2 SETS OF REGRESSION  
EQUATIONS, HAS BEEN ADDED.  
Reason:            The type 0 member is added to the  
Data Base.  
System Action:    The member is added to the Data Base.  
User Action:        None.

CBM330I      MEMBER survey membername, WITH nn ANTHROPOMETRIC  
VARIABLES AND nn1 PERCENTILES, AND REFERENCING  
SURVEY regression membername HAS BEEN ADDED.  
Reason:            The type 1 member is added to the  
Data Base.  
System Action:    The member is added to the Data Base.  
User Action:        None.

CBM331A      membername HAS NOT BEEN ADDED DUE TO nnn ERRORS.  
Reason:            After checking the member defini-  
tion, nnn syntax errors were found.  
System Action:    The member is not added to the Data  
Base.  
User Action:        Correct the errors, and resubmit.

CBM332A      MEMBER membername CHECKED - nnnnn ERRORS.  
Reason:            After checking the member defini-  
tion, nnnnn syntax errors were found.  
System Action:    None.  
User Action:        Correct the errors and resubmit.

CBM333I      MEMBER membername DELETED.  
Reason:            User requested +DEL function caused  
                         a member to be deleted from the Data  
                         Base.  
System Action:    Member deleted from Data Base.  
User Action:       None.

CBM334I      membername NOW IN PLACE.  
Reason:            User requested +CMP function caused  
                         member to be moved within Data Base,  
                         combining unused space.  
System Action:    Directory index in data base updated.  
User Action:       None.

CBM335I      membername WAS IN PLACE.  
Reason:            User requested +CMP function and the  
                         system found that the member member-  
                         name need not be moved.  
System Action:    Compression of Data Base continues.  
User Action:       None.

CBM336I      COMPRESS FINISHED.  
Reason:            Successful completion of +CMP func-  
                         tion.  
System Action:    Program execution continues.  
User Action:       None.

CBM337I      membername PUNCHED.  
Reason:            User initiated +PCH function for  
                         member membername successfully com-  
                         pleted.  
System Action:    Punching is completed.  
User Action:       None.

CBM339A      END-OF-DATA.  
Reason:            End of file found before END Program  
                         Control Card (+END) was found.  
System Action:    Terminates job.  
User Action:       Check that all control cards were  
                         processed.

CBM340A      MEMBER membername ALREADY EXISTS.  
Reason:            The user has tried to add an anthro-  
                         pometric member definition under a  
                         name that already exists in the Data  
                         Base.  
System Action:    The control card is ignored.  
User Action:       Use a new name and resubmit.

CBM341A DATA BASE IS NOT AN ANTHROPOMETRIC DATA BASE.  
Reason: First record of file does not contain "ANTH", the Anthropometric Data Base identificaton word.  
System Action: Terminates the program.  
User Action: Contact systems programmer.

CBM342A I/O ERROR ON RECORD nnnnn (INDEX).  
Reason: An I/O error has occurred in the directory of the Anthropometric Data Base.  
System Action: Terminates the program.  
User Action: Contact systems programmer.

CBM343A I/O ERROR ON RECORD nnnnn (DATA).  
Reason: An I/O error has occurred in a member definition on the Anthropometric Data Base.  
System Action: Terminates the program  
User Action: Contact systems programmer.

CBM399I PROGRAM END.  
Reason: The +END Control Card was encountered, or the end of input cards was encountered, or there was an I/O error.  
System Action: Terminates the program.  
User Action: Check that all control cards were accepted, and processed correctly.

## SECTION 5

### COMBIMAN CREW STATION DATA BASE MAINTENANCE PROGRAM (CBMCM)

The COMBIMAN system is an effective tool to analyze and evaluate crew stations. These crew stations may already be in use, or may exist only as an engineer's drawing. The best way to make these crew stations available to the man-model in the interactive graphics program CBM05 is to store the three dimensional coordinates of the panels and controls of the crew station on a Data Base accessed by CBM05. The program CBMCM is developed to assist the user to create and to maintain such a Crew Station Data Base. The data flow for the program CBMCM is shown in Figure 100.

The Crew Station Data Base contains definitions which describe the crew stations geometrically. Typical crew stations are aircraft cockpits, driver's area of an automobile, etc. To define a crew station, the user must supply the definition and 3-D coordinates of the vertices of the "panels" which make up the crew stations and controls found on and about the defined panels. Each crew station in the Data Base is called a "member", and is referenced by its membername.

#### 5.1 AVAILABLE PROCESSING

The program CBMCM allows the user to create and maintain the Crew Station Data Base. Input supplied by the user, on 80 character computer cards or in card image format (80 character records) on a magnetic tape or any other device, is read into the program CBMCM and is processed according to the control card commands selected by the user. These commands allow the user to add or delete members, to print or punch existing members, or to list the contents of the Data Base and its directory. The program is also used to compress the members within the Data Base.

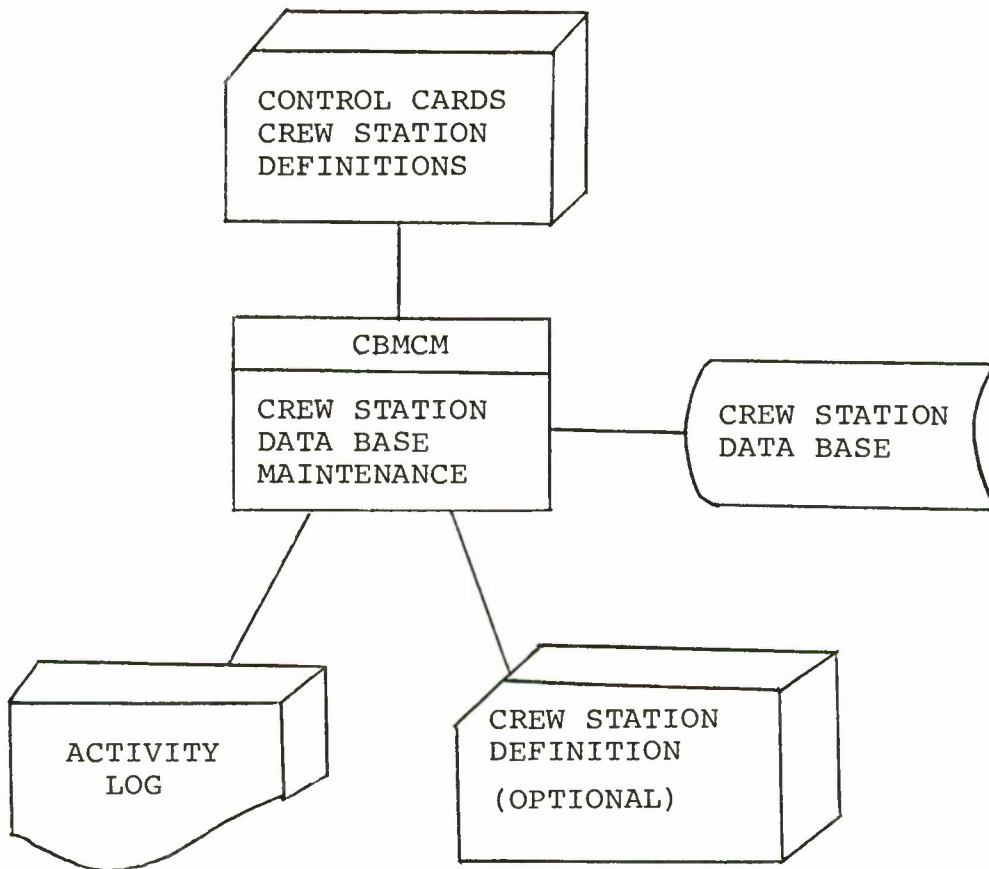

Figure 100. Data Flow for Program CBMCM.

The control cards for CBMCM may be input in any order with one exception. If the Data Base is created for the first time, or if it is reinitialized, the \$INT (Initialize) control card must precede all other control cards and member definitions.

## 5.2 RESTRICTIONS AND LIMITATIONS

The Crew Station Data Base may contain up to 20 members. The sum of the record counts for all the members may not exceed 1979 records. Information on the number of members on the Data Base and their size may be obtained by using the \$PRT control card, omitting reference to any membername. Membernames are limited to 8 alphanumeric characters. A member definition may contain a maximum of 300 panels and 300 controls. Additional limitations are described in Paragraph 5.3.2, "Processing Specifications."

## 5.3 HOW TO USE PROGRAM CBMCM

The example used to illustrate this program is based on the crew station in Figure 101, a seven-drawer desk. In modeling the desk, only the top, front side, and leg are defined. The other sides are not needed because they do not cause any physical or visual interference to the man-model seated at a desk.

### 5.3.1 Input Data Specification

Using the dimensions of the desk, and the origin as indicated in the figure, three dimensional coordinates are obtained for the various vertices of the panels and for the locations of the controls. The program CBMCM is set up to accept crew station definitions in any three dimensional cartesian coordinate system. The coordinate system for COMBIMAN

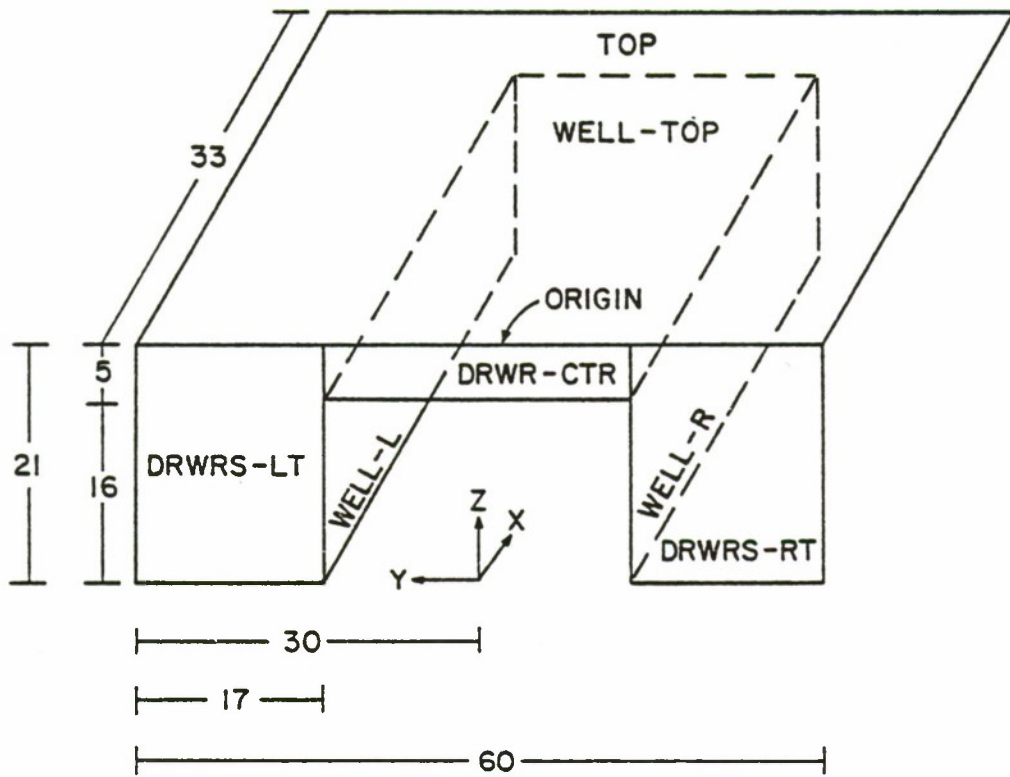

Figure 101. Sample Crew Station - DESK.

is a right handed system (positive x forward, positive y to the left, and positive z up). The user must supply the program CBMCM with the three-dimensional coordinates of the Seat Reference Point (SRP) with respect to the origin of the crew station's coordinate system. From these data, the program converts all input coordinates of the panels and controls to the coordinate system of the COMBIMAN.

Figure 102 shows an example of a typical Aircraft Coordinate system and its related COMBIMAN Coordinate system.

Panels for the crew station must have three to six vertices. Coordinate data for these vertices are entered into the program consecutively, going either clockwise or counterclockwise along the perimeter of the panel. Some examples of valid and invalid panels are shown in Figure 103. A total of seven panels make up the DESK in the example. Each panel has four vertices, and is rectangular in shape. The coordinates of the vertices are shown in Figures 104 and 105. If a panel has more than 6 vertices, or has a curved edge so that more than 6 vertices are required to approximate the curve, the panel must be subdivided into multiple panels of three to six vertices.

Controls are defined by either absolute or relative coordinates. If the control is not placed on a panel, it must be defined in absolute coordinates, that is, those of the crew station coordinate system. Before storing on the Data Base, the coordinates are translated and rotated to the COMBIMAN system of coordinates by CBMCM.

If the control is located on a defined panel, its coordinates can be given relative to any vertex of the panel. In this instance, the x- and y-displacements are given relative to the vertex number specified. The z-value must be zero.

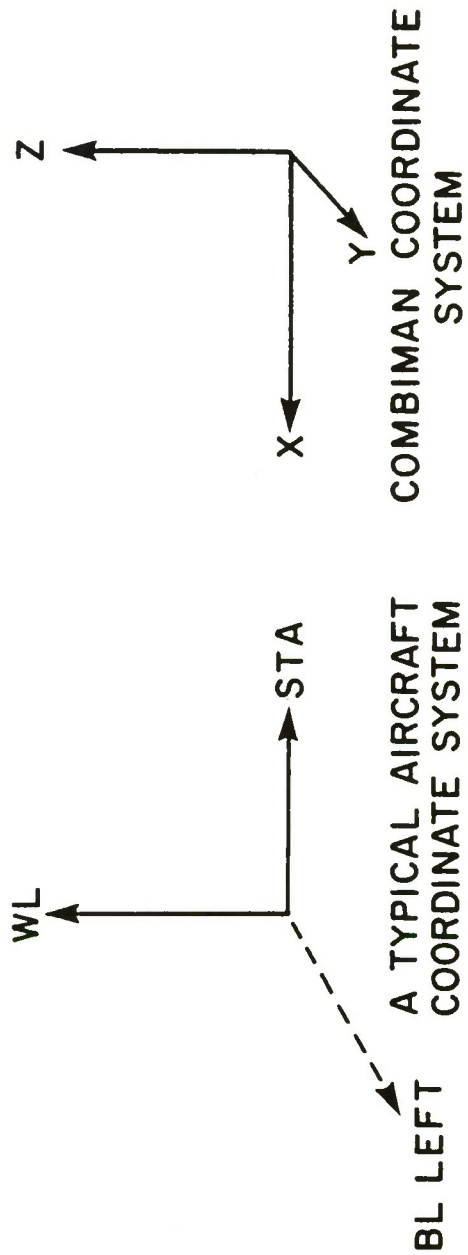
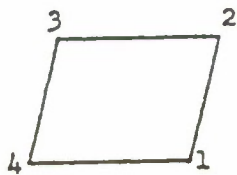
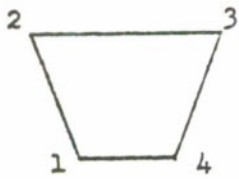
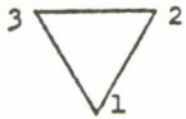
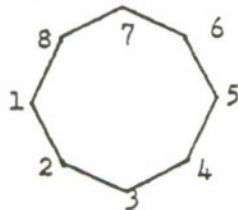
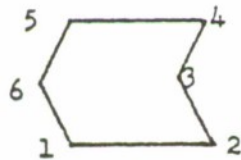
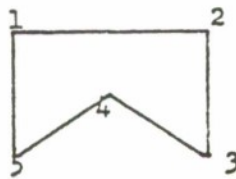
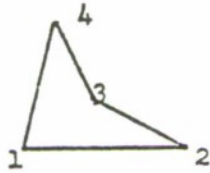

Figure 102. An Example of a Typical Aircraft Coordinate System and Its Related COMBIMAN Coordinate System.

Valid Panel Shapes



Invalid Panels



Line between vertices 2 and 4 would not lie within the panel.

Line between vertices 3 and 5 would not lie within the panel.

Line between vertices 2 and 4 would not lie within the panel.

Panel is convex, but has 8 vertices, 2 more than allowed.

Figure 103. Example of Valid and Invalid Panels.

ITOP



<u>POINT</u>	<u>X</u>	<u>Y</u>	<u>Z</u>
1	0.0	30.0	0.0
2	33.0	30.0	0.0
3	33.0	-30.0	0.0
4	0.0	-30.0	0.0

2DRWRS - LT



<u>POINT</u>	<u>X</u>	<u>Y</u>	<u>Z</u>
1	0.0	30.0	0.0
2	0.0	13.0	0.0
3	0.0	13.0	-21.0
4	0.0	30.0	-21.0

3 DRWRS - RT



<u>POINT</u>	<u>X</u>	<u>Y</u>	<u>Z</u>
1	0.0	-30.0	0.0
2	0.0	-13.0	0.0
3	0.0	-13.0	-21.0
4	0.0	-30.0	-21.0

4 DRWRS - CT



<u>POINT</u>	<u>X</u>	<u>Y</u>	<u>Z</u>
1	0.0	13.0	0.0
2	0.0	13.0	-5.0
3	0.0	-13.0	-5.0
4	0.0	-13.0	0.0

Figure 104. X, Y and Z Coordinates of Panels of DESK.

1	4
2	3

5 WELL - LT

<u>POINT</u>	<u>X</u>	<u>Y</u>	<u>Z</u>
1	0.0	13.0	-5.0
2	0.0	13.0	-21.0
3	33.0	13.0	-21.0
4	33.0	13.0	-5.0

1	4
2	3

6 WELL - RT

<u>POINT</u>	<u>X</u>	<u>Y</u>	<u>Z</u>
1	0.0	-13.0	-5.0
2	0.0	-13.0	-21.0
3	33.0	-13.0	-21.0
4	33.0	-13.0	-5.0

2	3
1	4

7 WELL - TOP

<u>POINT</u>	<u>X</u>	<u>Y</u>	<u>Z</u>
1	0.0	13.0	-5.0
2	33.0	13.0	-5.0
3	33.0	-13.0	-5.0
4	0.0	-13.0	-5.0

Figure 105. X, Y and Z Coordinates of Panels of DESK.

The x-displacement is the offset from the vertex number n in the direction of the line connecting the nth and (n-1)th vertices. The y-displacement is in direction of the line connecting nth and (n+1)th vertices. The convention for determining the location of a control in a panel relative to its vertices is shown in Figure 106.

### 5.3.2 Processing Specifications

Program CBMCM allows the user to maintain the Data Base by adding, deleting, listing, etc. the crew station definitions. The formats to request the functions are shown in Figure 107. These requests (one request per card) plus the crew station definitions are used as input to the program. The control cards may be input in any order with one exception: when the Data Base is initialized or reinitialized, the \$INT control card must be the first input data card. The control card formats are described in the following paragraphs.

#### 5.3.2.1 ADD CREW STATION MEMBER Function \$ADD membername npnls nctls srpx

srpy srpz x y z (followed by a crew station definition).

The ADD CREW STATION MEMBER function adds the specified data under the name membername to the Crew Station Data Base. The membername is limited to a length of eight characters. The crew station definition contains npnls panels, and nctls controls. These numbers should be entered as integers, right justified in their three digit fields. The Seat Reference Point (SRP) coordinates are srpx, srpy, and srpz and are entered in F6.2 Format. If a decimal point is omitted, the program CBMCM will assume a decimal point between the second and third digits from the right. The directions of the positive x, y, and z coordinate axes are indicated by the characters in the x, y, and z fields respectively. The possible values for x, y, and z are F for Forward, A for Aft, L for



Left, R for Right, U for Up, and D for Down. These directions are given with respect to the seated crewmember. If the crew station represents a seat, the last four letters of its member-name should be "SEAT".

For each crew station panel there are two format data cards, shown in Figures 108 and 109. In Figure 108, columns 1-3 contain an integer sequence number of the panel, right justified in the field. The first panel entered should have the sequence number "1". Panel numbers need not be consecutive, but they must be unique. Columns 4-11 contain the eight-character name of the panel. Columns 15-17 contain the panel type, as an integer, right justified. The panel types are "0" or "1" for general crew station panel, "2" for seat panel, and "3" for a rudder/brake pedal panel. If no type code is specified, "1" is assumed. Column 18 contains the number of vertices of the panel; the panel must have 3 to 6 vertices. The x, y and z coordinates of each vertex are entered consecutively, going either clockwise or counterclockwise around the perimeter of the panel.

Each control is defined on a card using the format in Figure 110. The control name is listed in columns 1-8. If the control is defined relative to a vertex, pn1# references a previously defined panel and is entered as an integer value, right justified in the field. The vertex to which the control is defined relative to is specified in the one-digit field v#. If a non-zero value is entered for pn1#, a non-zero value must be entered for the field v#. If the location is relative to a defined panel, the z-field is left blank. If the location of the control is absolute, x, y, and z values must be supplied. The coordinates of the control are assumed to be real numbers. If no decimal point is supplied, the program assumes a decimal point between the second and third digits from the right.



An example of the input definition for the member "DESK" is shown in Figure 111. The first outlined area is the \$ADD control card. The second outlined area shows the panel definition cards followed by the control definition cards in outlined area (3).

If the program detects an error in the input data for a member, the member will not be added to the Data Base.

#### 5.3.2.2 CHECK CREW STATION MEMBER Function

```
$CHK membername npnl nc srpx srpy  
srpz x y z (followed by a crew station  
definition).
```

The CHECK CREW STATION MEMBER function operates in the same way the ADD CREW STATION MEMBER function does, EXCEPT that the member is not added. This function checks new member input data for proper format and content.

#### 5.3.2.3 DELETE CREW STATION MEMBER Function

```
$DEL membername
```

The DELETE CREW STATION MEMBER function removes the specified crew station member from the Data Base, but does NOT make the space occupied by the member available for reuse. In order to make the space available to add more crew stations, the COMPRESS CREW STATION DATA BASE function must be used.

\$ADD OESK	7	8	-15.0	0.0	-11.0	F	L	U				
1TOP	04	0.0	30.0	0.0	33.0	30.0	0.0	33.0	-30.0	0.0		
0.0 -30.0	0.0											
2DRWRS-LT	04	0.0	30.0	0.0	0.0	13.0	0.0	0.0	13.0	-21.0		
0.0 30.0	-21.0											
3DRWRS-RT	04	0.0	-30.0	0.0	0.0	-13.0	0.0	0.0	-13.0	-21.0		
0.0 -30.0	-21.0											
4DRWRS-CT	04	0.0	13.0	0.0	0.0	13.0	-5.0	0.0	-13.0	-5.0		
0.0 -13.0	0.0											
5WELL-LT	04	0.0	13.0	-5.0	0.0	13.0	-21.0	33.0	13.0	-21.0		
33.0 13.0	-5.0											
6WELL-RT	04	0.0	-13.0	-5.0	0.0	-13.0	-21.0	33.0	-13.0	-21.0		
33.0 -13.0	-5.0											
7WELL-TOP	04	0.0	13.0	-5.0	33.0	13.0	-5.0	33.0	-13.0	-5.0		
0.0 -13.0	-5.0											
L-F-CRNR	0 12	0.0	0.0									
L-S-CRNR	0 11	0.0	0.0									
R-F-CRNR	0 13	0.0	0.0									
R-S-CRNR	0 14	0.0	0.0									
ORWRCTNR	0 42	0.0	-13.0									
ORWRLB	0 00	-1.0	22.0	-19.0								
ORWRLC	0 00	-1.0	22.0	-13.0								
ORWRLT	0 00	-1.0	22.0	-7.0								

(1)

(2)

(3)

Figure 111. Sample Data for \$ADD Member Function.

5.3.2.4 COMPRESS CREW STATION DATA BASE Function  
\$CMP

The COMPRESS CREW STATION DATA BASE function compresses used space together maximizing the amount of continuous unused space. The intermediate blocks of unused space are created by the DELETE CREW STATION MEMBER function. When the message "CBM127A NO SPACE, CANNOT ADD membername" appears while adding a crew station it is necessary to use this function. If the \$ADD function gives the CBM127A message immediately after the \$CMP function, the Data Base is full.

5.3.2.5 DUMP CREW STATION MEMBER Function

\$DMP membername  
\$DMP

The DUMP CREW STATION MEMBER function prints the contents of the crew station member membername, or prints the complete Crew Station Data Base if member name is omitted on the control card. The format of the display is:

```
RECORD nn ==+ (record in EBCDIC)          ==+
==+ (record in hexadecimal)              ==+
==+ (rest of record in hexadecimal)      ==+
```

The ==+ characters act as delimiters of the displayed data. This function is used primarily by system programmers to test the file.

5.3.2.6 END PROGRAM Function

\$END

The END PROGRAM function terminates execution of the program CBMCM.

5.3.2.7 INITIALIZE CREW STATION DATA BASE  
Function

\$INT

The INITIALIZE CREW STATION DATA BASE function resets the Data Base to the original unused state. The primary purpose of this function is to establish a Crew Station Data Base.

5.3.2.8 PUNCH CREW STATION MEMBER Function

\$PCH membername

The PUNCH CREW STATION MEMBER function punches a copy of the specified member in a format that the ADD CREW STATION MEMBER function requires. Specifying a membername that does not exist on the directory will result in a printout of all the membernames on the Data Base.

5.3.2.9 PRINT CREW STATION MEMBER Function

\$PRT membername  
\$PRT

The PRINT CREW STATION MEMBER function prints the contents of the specified member, membername, in a format similar to that of the ADD CREW STATION MEMBER function. Specifying no name, or a nonexisting name causes a printout of the index containing membernames, their record locations on the Data Base, and the origin and orientation of their coordinate systems.

5.3.3 Submitting a Processing Request

The sequence of JOB CONTROL LANGUAGE (JCL) cards needed to execute the program CBMCM are shown in Figure 112. All function control cards and member definition cards follow

```

//CBMCM      JOB  HESS
//JOBLIB    DD  USN=COMBIMAN.LOADLIB,DISP=SHR
//CBMCM      EXEC  PGM=CBMCM
//FT01F001  DD  USN=COMBIMAN.CRSTDATA,DISP=SHR
//FT05F001  DD  UUNAME=SYSIN
//FT06F001  DD  SYSOUT=A
//FT07F001  DD  SYSOUT=B
//SYSUDUMP  DD  SYSOUT=A
//SYSIN     DD  *

```

```

CBMCM FUNCTION CONTROL CARDS AND
MEMBER DEFINITION DATA

```

```

/*
//

```

Figure 112. Job Control Cards to Execute Program CBMCM.

```

//FT01F001  DD  DSN=COMBIMAN.CRSTDATA,UNIT=DISK,DISP=(NEW,CATLG),
//              VOL=SEQ=DISK01,SPACE=(368,2000),
//              UCBS=(BLKSIZE=368,LRECL=368,RECFM=FB)

```

Figure 113. FT01 DD Card to Allocate Space on Disk and Execute Program CBMCM.

the "//SYSIN DD\*" card. The "//FT01F001" DD card included in this sequence assumes that the space for the Data Base has already been allocated on disk. If the Data Base does not exist, the "//FT01F001" DD card specified in Figure 112 should be replaced by the sequence of cards shown in Figure 113. This sequence to allocate space for the Data Base and to initialize it should be executed only once. Thereafter, the simplified "//FT01F001" DD card shown in Figure 112 should be used for all file manipulations.

Once the Data Base is allocated on Disk, it must be initialized using \$INT function before using any other function. For every CBMCM job, the last function control card read into the program should be the "\$END" card.

#### 5.3.4 Output Data Interpretation

The program CBMCM generates output to the card punch, disk file, or printer, depending on the specified control card function. The formats for the printed output will be discussed in this section. Punched records have the same format as the input data records discussed in Paragraph 5.3.2. The physical format of the records on the Data Base is not described here.

Five basic formats are used by CBMCM for printed output. These format types, their use, and their examples are presented in this subsection. All types begin with the same heading "CBMCM", the date and time of the program execution, and page number.

The first type of output is generated by the INITIALIZE, PUNCH, COMPRESS, DELETE, and END functions. The output indicates the start and end of processing associated with the specified function. For the COMPRESS function additional

messages indicating that a particular member is, or is not moved in the process of combining unused space is also printed. An example of this format, for the COMPRESS function, is shown in Figure 114.

The second type of output is generated by the PRINT or PUNCH functions when the \$PRT or \$PCH control card is supplied with blank membername field. This causes the index of the Data Base printed in the following format:

nn.) membername, EXTENT=(n1,n2), np PANELS, nc CONTROLS,  
ORIGIN=(xx, yy, zz), ORIENT=(a, b, c)

where:

<u>nn</u>	is the number of the member identification record within the directory
<u>membername</u>	is the name of the member identified
<u>n1</u>	is the location of the first record which defines this member
<u>n2</u>	is the location of the last record which defines this member
<u>np</u>	is the number of panels associated with this member
<u>nc</u>	is the number of controls associated with this member
<u>xx</u> <u>yy</u> <u>zz</u>	is the location of the seat reference point with respect to the origin of the coordinate system of the crew station
<u>a</u>	is the orientation of the positive x-axis of the crew station
<u>b</u>	is the orientation of the positive y-axis of the crew station
<u>c</u>	is the orientation of the positive z-axis of the crew station

An example of the PRINT function is shown in Figure 115.

```

CBM1001 $CMP
CBM1281 HAC1 WAS IN PLACE.
CBM1281 A7E WAS IN PLACE.
CBM1281 A7 WAS IN PLACE.
CBM1281 FWC1 WAS IN PLACE.
CBM1281 A7-01 WAS IN PLACE.
CBM1281 A7E-01 WAS IN PLACE.
CBM1291 B1-CHAIR NOW IN PLACE.
CBM1291 B1-NAV01 NOW IN PLACE.
CBM1291 B1-NAV1A NOW IN PLACE.
CBM1291 B1-NAV2A NOW IN PLACE.
CBM1291 SACR NOW IN PLACE.
CBM1291 DESK NOW IN PLACE.
CBM1381 COMPRESS FINISHED.

```

Figure 114. A Sample Output of the \$CMP Function.

```

CBM1001 $PRT
9.) SACR , EXTENT=) 782, 1 CUNTRLS, ORIGIN=( -27.00, 59.25, -15.75), ORIENT.=)F,k,U).
10.) SACR , EXTENT=( 806, 1 CUNTRLS, ORIGIN=) -27.00, 19.25, -15.75), ORIENT.=)F,R,U).
11.) B1-NAVZA, EXTENT=) 754, 1 CUNTRLS, ORIGIN=) 22.00, 396.61, 62.50), ORIENT.=)R,A,U).
12.) B1-CHAIR, EXTENT=) 689, 1 CUNTRLS, ORIGIN=) 0.0, 0.0, 0.0), ORIENT.=)A,R,U).
13.) B1-NAV1A, EXTENT=) 724, 1 CUNTRLS, ORIGIN=( 22.00, 396.61, 62.50), ORIENT.=)R,A,U).
14.) B1-NAV01, EXTENT=) 694, 1 CUNTRLS, ORIGIN=( 22.00, 396.61, 62.50), ORIENT.=)R,A,U).
15.) A7E-01 , EXTENT=) 592, 46 CUNTRLS, ORIGIN=( 0.0, 0.0, 0.0), ORIENT.=)F,L,U).
16.) A7-01 , EXTENT=) 489, 46 CUNTRLS, ORIGIN=( 0.0, -5.60, -4.25), ORIENT.=)R,F,U).
17.) A7 , EXTENT=) 350, 46 CUNTRLS, ORIGIN=( 0.0, 0.0, 0.0), ORIENT.=)R,F,U).
18.) FWC1 , EXTENT=) 461, 1 CUNTRLS, ORIGIN=( 5.00, 0.0, 3.00), ORIENT.=)F,L,U).
19.) A7E , EXTENT=) 45, 109 CUNTRLS, ORIGIN=( 0.0, 103.40, 265.00), ORIENT.=)R,D,A).
20.) HAC1 , EXTENT=( 22, 5 CUNTRLS, ORIGIN=( 16.00, 0.0, 18.00), ORIENT.=)F,L,U).
21.) DESK , EXTENT=) 830, 8 CUNTRLS, ORIGIN=( -15.00, 0.0, -11.00), ORIENT.=)F,L,U).

```

Figure 115. A Sample Output of the \$PRT (No Membername) Function.

The third type of output is generated by the DUMP function. This function is intended to be used primarily by system programmers to locate the cause of I/O (Input/Output) errors on the Data Base. For the member specified on the \$DMP control card, a message giving directory or index information is printed using the second output format described elsewhere. Each data record associated with the member is printed in the following format:

```

RECORD nn +=+ (record in EBCDIC)           +=+
+=+ (record in hexadecimal)                 +=+
+=+ (remainder of record in hexadecimal)    +=+

```

where nn is the location of the record within the Data Base. The record in EBCDIC is printed using a 25A4 format. The record in hexadecimal is printed using a 10Z8 format. An example of the output for the DUMP function is shown in Figure 116.

The fourth output format is used by the CHECK and ADD functions. After reading the control card and checking it for errors, the information contained on the card is reformatted and written out to the printer. If any error is detected, the error messages pertaining to data contained on the card are printed first.

The panel definition cards, after being read and checked for errors, are printed in the following format:

```

nn.) pnl nm, TYPE=tt, nv VERTICES--INPUT COORD-- --ABSOLUTE
COORD --

      (xx1, yy1, zz1) (ax1, ay1, az1)
      .
      .
      .
      (xxnv, yynv, zznv) (axnv, aynv, aznv)

```



where:

nn is the panel number

pnl nm is the panel name

tt is the panel type

nv is the number of vertices used to define the panel

xx<sub>i</sub>,yy<sub>i</sub>,zz<sub>i</sub> are the x, y, and z coordinates for the i<sup>th</sup> vertex of the panel, in the crew station system of coordinates, where i=1, nv.

ax<sub>i</sub>,ay<sub>i</sub>,az<sub>i</sub> are the x, y, and z coordinates of the i<sup>th</sup> vertex of the panel, converted to the COMBIMAN system of coordinates, where i=1, nv.

After all the panel definition data are printed, CBMCM prints the control data using the following format:

cntl nm tt pnl ref. v.# (xx,yy,zz) TO (ax,ay,az) & (rx,ry)

where:

cntl nm is the 8 character name of the control

tt is the 2 digit control type

pnl ref is the panel where the control is located (if applicable)

v.# is the reference vertex number for that control (if applicable)

xx  
yy  
zz are the three dimensional coordinates (relative or absolute) which define the location of the control

ax  
ay  
az are the absolute three dimensional coordinates which define the location of the control in the COMBIMAN system of coordinates

rx  
ry are the two dimensional relative coordinates of the control. If the control is not defined relative to a panel, rx=ry=0.0.

An example of this fourth output format for the \$ADD function is shown in Figure 117.

The fifth and last format is similar to that used for the ADD function input, and is used for the PRINT function when a valid membername is specified. The main difference between this format and the fourth is that this format does not print the original input data used to add the member to the Data Base. After printing the index record for the member, the program CBMCM prints the panel definition data in the following format:

```
nn.) pnl nm, TYPE=tt, nv VERTICES--ABSOLUTE COORDINATES--  
                                     (xx1, yy1, zz1)  
                                     .  
                                     .  
                                     .  
                                     (xxnv, yynv, zznv)
```

where:

<u>nn</u>	is the panel number
<u>pnl nm</u>	is the 8-character name of the panel
<u>tt</u>	is the panel type
<u>nv</u>	is the number of vertices which define the panel
xx <sub>i</sub> ,yy <sub>i</sub> ,zz <sub>i</sub>	are the x, y, and z coordinates of the i <sup>th</sup> vertex of the panel, in the COMBI-MAN system of coordinates, where i=1, nv.

After printing the panel definition data, the program prints the control data using the following format:

```
cntl nm tt pnl ref v# (ax, ay, az) (rx, ry)
```

where:

<u>cntl nm</u>	is the 8 character name of the control
<u>tt</u>	is the 2 digit control type

```

CBM1001 $A00 DESK      7  8-15.00  0.0 -11.00 F L 0
CBM1191 MEMBER, DESK  , HAS  7 PANELS AND  8 CONTROLS.
CBM1201 COORDINATES ARE TRANSLATED TO ( -15.00,  0.0 , -11.00).
CBM1211 COORDINATES GIVEN AS F, L AND 0 ARE NOW F, L, AND 0.
1.) TOP      , TYPE= 0,  4 VERTICES  --INPUT COORDINATES--
(  0.0  30.00  0.0 ) TO (  48.00  30.00  11.00)
(  33.00  30.00  0.0 ) TO (  48.00  30.00  11.00)
(  33.00 -30.00  0.0 ) TO (  48.00 -30.00  11.00)
(  0.0 -30.00  0.0 ) TO (  15.00 -30.00  11.00)
--ABSOLUTE COORDINATES--
(  0.0  30.00  0.0 ) TO (  15.00  30.00  11.00)
(  0.0  13.00  0.0 ) TO (  15.00  13.00  11.00)
(  0.0  13.00 -21.00) TO (  15.00  13.00 -10.00)
(  0.0  30.00 -21.00) TO (  15.00  30.00 -10.00)
--ABSOLUTE COORDINATES--
2.) ORWRS-LT, TYPE= 0,  4 VERTICES  --INPUT COORDINATES--
(  0.0  30.00  0.0 ) TO (  15.00  30.00  11.00)
(  0.0  13.00  0.0 ) TO (  15.00  13.00  11.00)
(  0.0  13.00 -21.00) TO (  15.00  13.00 -10.00)
(  0.0  30.00 -21.00) TO (  15.00  30.00 -10.00)
--ABSOLUTE COORDINATES--
3.) ORWRS-RT, TYPE= 0,  4 VERTICES  --INPUT COORDINATES--
(  0.0 -30.00  0.0 ) TO (  15.00 -30.00  11.00)
(  0.0 -13.00  0.0 ) TO (  15.00 -13.00  11.00)
(  0.0 -13.00 -21.00) TO (  15.00 -13.00 -10.00)
(  0.0 -30.00 -21.00) TO (  15.00 -30.00 -10.00)
--ABSOLUTE COORDINATES--
4.) ORWRS-CT, TYPE= 0,  4 VERTICES  --INPUT COORDINATES--
(  0.0  13.00  0.0 ) TO (  15.00  13.00  11.00)
(  0.0  13.00 -5.00) TO (  15.00  13.00  6.00)
(  0.0 -13.00 -5.00) TO (  15.00 -13.00  6.00)
(  0.0 -13.00  0.0 ) TO (  15.00 -13.00  11.00)
--ABSOLUTE COORDINATES--
5.) WELL-LT , TYPE= 0,  4 VERTICES  --INPUT COORDINATES--
(  0.0  13.00 -5.00) TO (  15.00  13.00  6.00)
(  0.0  13.00 -21.00) TO (  15.00  13.00 -10.00)
(  33.00  13.00 -21.00) TO (  48.00  13.00 -10.00)
(  33.00  13.00 -5.00) TO (  48.00  13.00  6.00)
--ABSOLUTE COORDINATES--
6.) WELL-RT , TYPE= 0,  4 VERTICES  --INPUT COORDINATES--
(  0.0 -13.00 -5.00) TO (  15.00 -13.00  6.00)
(  0.0 -13.00 -21.00) TO (  15.00 -13.00 -10.00)
(  33.00 -13.00 -21.00) TO (  48.00 -13.00 -10.00)
(  33.00 -13.00 -5.00) TO (  48.00 -13.00  6.00)
--ABSOLUTE COORDINATES--
7.) WELL-TOP, TYPE= 0,  4 VERTICES  --INPUT COORDINATES--
(  0.0  13.00 -5.00) TO (  15.00  13.00  6.00)
(  33.00  13.00 -5.00) TO (  48.00  13.00  6.00)
(  33.00 -13.00 -5.00) TO (  48.00 -13.00  6.00)
(  0.0 -13.00 -5.00) TO (  15.00 -13.00  6.00)
--ABSOLUTE COORDINATES--
CONTROL- TYPE IN PANEL POINT ---INPUT COORDINATES--- RELATIVE-COORDINATES
L-F-CRNR  0 TOP      2 (  0.0  0.0  0.0 ) TO (  48.00  30.00  11.00) & (  0.0  0.0 )
L-S-CRNR  0 TJP     1 (  0.0  0.0  0.0 ) TO (  15.00  30.00  11.00) & (  0.0  0.0 )
R-F-CRNR  0 TOP     3 (  0.0  0.0  0.0 ) TO (  48.00 -30.00  11.00) & (  0.0  0.0 )
R-S-CRNR  0 TOP     4 (  0.0  0.0  0.0 ) TO (  15.00 -30.00  11.00) & (  0.0  0.0 )
ORWRCRNR  0 ORWRS-CT 2 (  0.0 -13.00  0.0 ) TO (  15.00  0.0  6.00) & (  0.0 -13.00)
ORWRLB   0         0 (  -1.00  22.00 -19.00) TO (  14.00  22.00 -8.00) & (  0.0  0.0 )
ORWRLC   0         0 (  -1.00  22.00 -13.00) TO (  14.00  22.00 -2.00) & (  0.0  0.0 )
ORWRLT   0         0 (  -1.00  22.00 -7.00) TO (  14.00  22.00  4.00) & (  0.0  0.0 )
CBM1341 DESK WITH  7 PANELS AND  8 CONTROLS HAS BEEN ADDED.

```

Figure 117. Example of Program CBMCM \$ADD (Membername) Function Output Format.

<u>pnl ref</u>	is the panel on which the control is located (if applicable)
<u>v#</u>	is the reference vertex number of the panel for that control (if applicable)
ax ay az	are the three dimensional coordinates which define the control in the COMBIMAN system of coordinates
rx ry	are the two dimensional relative coordinates of the control. If the control was not defined relative to a panel, rx=ry=0.0.

An example of the output for the \$PRT function using the fifth format is shown in Figure 118.

#### 5.4 PROGRAM MESSAGES - INCLUDING ERROR CORRECTION

The program CBMCM prints both information and action related messages. The message format is as follows:

CBMlnni                    message text

where

<u>nn</u>	is the message number
<u>i</u>	indicates the action code (I=informational, A=action to be performed), and
<u>message text</u>	is the text of the message.

Unless otherwise noted, all messages are generated by the routine CBMCM.

The messages are as follows:

CBM100I	<u>control card image</u>
	Reason:            User submitted a control card.
	System Action:    Continues processing.
	User Action:        None.

```

CBM1001 $PRT DESK
21.) DESK , EXTENT=( 830, 844), 7 PANELS, 8 CONTROLS, DRIGIN=( -15.00, 0.0 , -11.00), ORIENT.=(F,L,U).
1.) TOP , TYPE= 0, 4 VERTICES --ABSOLUTE COORDINATES--
( 15.00 30.00 11.00)
( 48.00 30.00 11.00)
( 48.00 -30.00 11.00)
( 15.00 -30.00 11.00)
2.) DRWRS-LT, TYPE= 0, 4 VERTICES --ABSOLUTE COORDINATES--
( 15.00 30.00 11.00)
( 15.00 13.00 11.00)
( 15.00 13.00 -10.00)
( 15.00 30.00 -10.00)
3.) DRWRS-RT, TYPE= 0, 4 VERTICES --ABSOLUTE COORDINATES--
( 15.00 -30.00 11.00)
( 15.00 -13.00 11.00)
( 15.00 -13.00 -10.00)
( 15.00 -30.00 -10.00)
4.) DRWRS-CT, TYPE= 0, 4 VERTICES --ABSOLUTE COORDINATES--
( 15.00 13.00 11.00)
( 15.00 13.00 6.00)
( 15.00 -13.00 6.00)
( 15.00 -13.00 11.00)
5.) WELL-LT , TYPE= 0, 4 VERTICES --ABSOLUTE COORDINATES--
( 15.00 13.00 6.00)
( 15.00 13.00 -10.00)
( 48.00 13.00 -10.00)
( 48.00 13.00 6.00)
6.) WELL-RT , TYPE= 0, 4 VERTICES --ABSOLUTE COORDINATES--
( 15.00 -13.00 6.00)
( 15.00 -13.00 -10.00)
( 48.00 -13.00 -10.00)
( 48.00 -13.00 6.00)
7.) WELL-TOP, TYPE= 0, 4 VERTICES --ABSOLUTE COORDINATES--
( 15.00 13.00 6.00)
( 48.00 13.00 6.00)
( 48.00 -13.00 6.00)
( 15.00 -13.00 6.00)
CONTROL - TYPE IN-PANEL PUJNT --ABSOLUTE COORDINATES-- RELATIVE-COORDINATE
-----
L-F-CRNR 0 TOP 2 ( 48.00 30.00 11.00) ( 0.0 0.0 )
L-S-CRNR 0 TOP 1 ( 15.00 30.00 11.00) ( 0.0 0.0 )
R-F-CRNR 0 TOP 3 ( 48.00 -30.00 11.00) ( 0.0 0.0 )
R-S-CRNR 0 TOP 4 ( 15.00 -30.00 11.00) ( 0.0 0.0 )
DRWRLTNR 0 DRWRS-CT 2 ( 15.00 0.0 6.00) ( 0.0 -13.00)
DRWRLB 0 ( 14.00 22.00 -8.00) ( 0.0 0.0 )
DRWRLC 0 ( 14.00 22.00 -2.00) ( 0.0 0.0 )
DRWRLT 0 ( 14.00 22.00 4.00) ( 0.0 0.0 )

```

Figure 118. A Sample Output the \$PRT Function.

CBM101A    operation UNKNOWN OPERATION.  
Reason:            The operation on the control card shown in the previous CBM100I message, is unknown.  
System Action:    Ignores this control card.  
User Action:       Correct the card and resubmit.

CBM102A    panelnumber INVALID PANEL NUMBER FOR POINT  
controlname.  
Reason:            The panel number specified by the control definition card does not exist.  
System Action:    Assumes that the control is defined in absolute coordinates.  
User Action:       Delete the crew station member, correct the card, and resubmit.

CBM103A    vertexnumber INVALID VERTEX NUMBER FOR POINT  
controlname.  
Reason:            The panel in which the control is defined does not have vertex vertexnumber.  
System Action:    Uses vertex number 1.  
User Action:       Delete the crew station member, correct the error, and resubmit.

CBM104A    Z NOT ZERO, PANEL & VERTEX NOW ZERO FOR POINT  
controlname.  
Reason:            A panel number and a vertex number are specified, but the Z value is not zero.  
System Action:    Makes Z zero and continues processing.  
User Action:       If setting Z equal to zero corrects the problem, no action needed. Otherwise, delete the crew station member, correct the data card and resubmit.

CBM105A    NO NAME GIVEN, operation IGNORED  
Reason:            This operation requires a crew station member name, but no name is specified.  
System Action:    Ignores the operation.  
User Action:       Supply the member name and resubmit.

CBM106A    membername NOT FOUND.  
Reason:            For the DELETE, DUMP, PUNCH or PRINT function, the specified crew station member name does not exist.  
System Action:    Prints the Crew Station Data Base directory.  
User Action:       Correct the error and resubmit.

CBM107A NUMBER OF PANELS/CONTROLS INVALID FOR MEMBER membername.  
Reason: The number of panels or controls as specified on the ADD function control card (\$ADD) is either less than 1 or greater than 300.  
System Action: Ignores the control card.  
User Action: If the number as specified is less than 1, correct and resubmit. If the number as specified is greater than 300, split the crew station definition into two units and add them separately.

CBM109A axis FOR Y INVALID, MEMBER IS membername.  
Reason: During the ADD function (\$ADD), the direction of the user's Y-axis is not F, A, L, R, U or D.  
System Action: Ignores the control card.  
User Action: Correct the control card and resubmit.

CBM110A axis FOR Z INVALID, MEMBER IS membername.  
Reason: During the ADD function (\$ADD), the direction of the user's Z-axis is not F, A, L, R, U or D.  
System Action: Ignores the control card.  
User Action: Correct the control card and resubmit.

CBM111A X&Y, X&Z OR Y&Z ARE COLINEAR FOR MEMBER membername.  
Reason: The directions of two or more of the user's axes are the same (ex. X=L, Y=U & Z=U or X=L, Y=U & Z=L).  
System Action: Ignores the control card.  
User Action: Pick unique directions for the axes and resubmit.

CBM112A DIRECTORY IS FULL, CANNOT ADD membername.  
Reason: No space is available in the Crew Station Data Base directory to add an entry for this member.  
System Action: Ignores the control card.  
User Action: Delete a member and resubmit.

CBM113A PANEL IS ZERO, BUT POINT IS NOT FOR membername.  
Reason: In defining a control, either the panel number and the vertex number must be zero, or both numbers must be non-zero. Note that blank entry is converted to zero.  
System Action: Takes the control definition as absolute.  
User Action: Delete the crew station, correct the error and resubmit.

CBM114A     membername ALREADY EXISTS.  
Reason:            User tried to add a crew station  
                    definiton under a name that already  
                    exists on the Data Base.  
System Action:    Ignores the control card.  
User Action:       Use a new name, and resubmit.

CBM115A     END OF DATA.  
Reason:            The end of file was found before the  
                    END Program control card (\$END).  
System Action:    Terminates the program.  
User Action:       Check to make sure that all the  
                    control cards are processed.

CBM116A     I/O ERROR ON RECORD recordnumber (INDEX).  
Reason:            An I/O error occurred on the Crew  
                    Station Data Base.  
System Action:    Terminates the program.  
User Action:       Contact systems programmmer.

CBM117A     I/O ERROR ON RECORD recordnumber (DATA).  
Reason:            An I/O error occurred on the Crew  
                    Station Data Base.  
System Action:    Terminates the program.  
User Action:       Contact systems programmer.

CBM119A     NEW MEMBER, membername, HAS nn PANELS AND nn  
CONTROLS.  
Reason:            The user added a crew station de-  
                    finition to the Data Base.  
System Action:    The new crew station is added to the  
                    Data Base .  
User Action:       None.

CBM120I     COORDINATES ARE TRANSLATED TO seat reference point  
coordinate.  
Reason:            The user added a crew station de-  
                    finition to the Data Base.  
System Action:    The addition is accepted.  
User Action:       None.

CBM121I     COORDINATES GIVEN AS axis, axis AND axis ARE NOW R,  
F, AND U.  
Reason:            The user added a crew station de-  
                    finition to the Data Base.  
System Action:    The addition is accepted.  
User Action:       None.

CBM122I PROGRAM END.  
Reason: The End Program function control card (\$END) or the end of the file card is encountered, or there is an I/O error.  
System Action: Terminates the program.  
User Action: Check to make sure that all control cards are accepted, and processed correctly.

CBM123I membername DELETED.  
Reason: The user submitted a delete Crew Station Definition function control card (\$DEL).  
System Action: Makes the requested deletion.  
User Action: None.

CBM124I INITIALIZED.  
Reason: The user requested that the Crew Station Data Base be initialized.  
System Action: The Data Base is initialized.  
User Action: None.

CBM125A PANEL NOT DEFINED FOR CONTROL controlname.  
Reason: To define a control, the user specified the control in a panel not found in this crew station.  
System Action: Assumes that the control is defined absolutely.  
User Action: Make sure that the panel is defined. Correct and resubmit.

CBM126I membername PUNCHED.  
Reason: The user requested that member membername be punched on cards.  
System Action: Punches the data.  
User Action: None.

CBM127A NO SPACE, CANNOT ADD membername.  
Reason: There is not enough space in the data base to hold the requested addition.  
System Action: Ignores the control card.  
User Action: Compress the Data Base and resubmit.

CBM128I membername WAS IN PLACE.  
Reason: The user requested that the Data Base be compressed. The member, membername, was already compressed and not moved.  
System Action: The named member was not moved.  
User Action: None.

CBM129I     membername NOW IN PLACE.  
Reason:             The user requested that the Data Base be compressed. The member, membername was not in place, and therefore has been moved to facilitate compression.  
System Action:     The member is moved to another location in the Data Base.  
User Action:        None.

CBM130A     panelname USED IN PANELS panelnumber1 AND panelnumber2.  
Reason:             In the crew station member definition, two panels have the same name. The number of these panels are panelnumber1 and panelnumber2.  
System Action:     Both panels are accepted in spite of the duplicate names.  
User Action:        Delete the definition, change one of the names, and resubmit.

CBM131A     panelname HAS SAME PANEL NUMBER AS panelnumber.  
Reason:             In the crew station definition, two panels have the same panel number.  
System Action:     Both panels are accepted. Note that references to the second will cause a reference to the first.  
User Action:        Delete the crew station definition, correct the error, and resubmit.

CBM132A     controlname IS A DUPLICATE NAME.  
Reason:             In adding a crew station definition, two controls have the same name.  
System Action:     Only the first control can be referenced.  
User Action:        Delete the definition, change one of the names to make it unique, and resubmit.



## SECTION 6

### COMBIMAN VISIBILITY DATA BASE MAINTENANCE PROGRAM (CBMVM)

One of the important functions provided by the interactive program CBM05 is the VISIBILITY PLOT function. This function evaluates the interaction of the visual man-model with a crew station. It uses the eye location of the current man-model and the three dimensional coordinates of selected crew stations, stored on the Visibility Data Base, to generate on-line plots of the man-model's field of vision. Note that the Visibility Data Base may contain the same geometric panels as the Crew Station Data Base, or alternately a subset of the Crew Station Data Base, or an entirely different set of panels and contours. A data flow of the program CBMVM is shown in Figure 119.

#### 6.1 AVAILABLE PROCESSING

The program CBMVM allows the user to create and maintain the Visibility Data Base. Input data are supplied on 80-character computer cards or card images on magnetic tape or direct access device and are processed according to the user's selection of control commands. These commands allow the user to add or delete members, to print information about existing members, or to list contents of the Data Base. It can also be used to compress the members within the Data Base to maintain continuous blocks of available disk space.

The control cards may be input in any order with one exception: when the Data Base is created for the first time or is reinitialized, the \$INT (initialize) control card must precede all other control cards and member definitions.

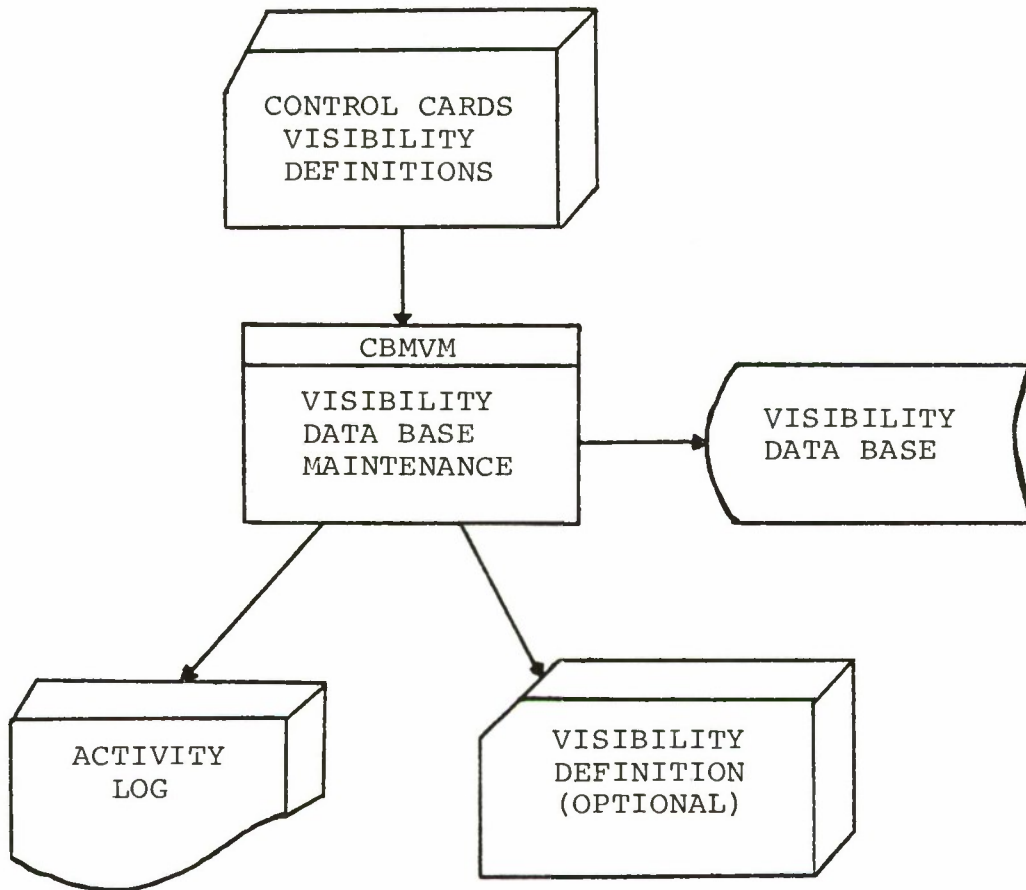

Figure 119. Data Flow for Program CBMVM.

## 6.2 RESTRICTIONS AND LIMITATIONS

A maximum of 20 crew station members may be added to the Visibility Data Base. Each member may contain up to 15 panels or contours. The panels and contours may consist of two to 100 vertices. The large number of vertices per panel allows a greater accuracy of approximating curved edges than is possible with the Crew Station Data Base. These vertices must be input in consecutive order, as described in Paragraph 6.3.1.

The total number of records available for coordinate information for members on the Visibility Data Base is 1979. Other limitations are described in Paragraph 6.2.3.

## 6.3 HOW TO USE CBMVM

The example used to illustrate this program is based on the A7E-01 crew station shown with the seated man-model as shown in Figure 4. The panels and edges of the A7E-01 crew station are combined to produce a visibility member consisting of three panels: the upper and lower windows, and the cockpit canopy. These panels are shown in Figure 120, along with the three-dimensional coordinates used to define points along the panel boundaries.

### 6.3.1 Input Data Specification

Input data format to CBMVM is similar to that of CBMCM, except that the adjacent panels and edges can be combined into panels for input to CBMVM.

The program CBMCM is set up to accept any three dimensional cartesian coordinate system. The user must also supply the program with the three-dimensional coordinates of the Seat Reference Point (SRP) with respect to the origin of crew station coordinate system.

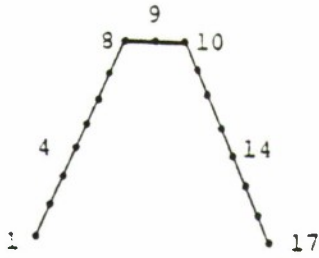

WINDSCREEN, FRONT TOP (17)

POINT:	x	y	z
1.	227.63	5.34	125.35
2.	223.79	5.51	123.24
3.	220.98	5.46	121.57
4.	218.93	5.19	120.59
5.	215.79	4.36	118.76
6.	213.14	4.27	117.35
7.	211.09	3.62	116.16
8.	209.14	2.31	115.34

(Points 10-17 are the same as 9-1 with the sign of the y value changed)

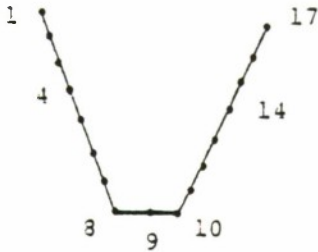

WINDSCREEN, FRONT BOTTOM (17)

POINT:	x	y	z
1.	227.63	5.34	125.35
2.	230.00	5.73	126.65
3.	232.12	5.68	127.34
4.	234.44	5.41	129.03
5.	237.31	4.70	130.59
6.	239.41	4.05	131.73
7.	241.09	2.92	132.36
8.	242.12	2.00	133.41
9.	242.12	0.00	133.41

(Points 10-17 are the same as 3-1 with the sign of the y value changed)

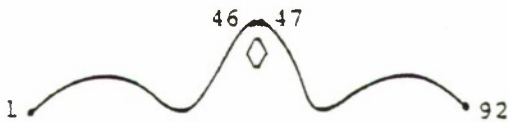

COCKPIT CANOPY CLEARLINE (92)

	x	y	z	x	y	z	x	y	z		
1.	294.47	0.00	135.50	16.	286.78	19.41	116.98	31.	255.59	17.93	114.30
2.	294.04	2.47	134.50	17.	285.96	19.30	116.76	32.	254.59	16.97	114.50
3.	293.61	6.22	133.26	18.	284.71	19.30	116.54	33.	252.92	15.78	115.77
4.	293.22	8.32	132.01	19.	282.81	19.14	116.41	34.	251.92	14.70	117.45
5.	292.61	10.54	130.24	20.	281.34	19.08	116.29	35.	251.32	13.89	118.57
6.	292.09	12.43	128.60	21.	279.87	18.97	116.16	36.	250.69	13.35	119.70
7.	291.62	13.78	127.00	22.	277.67	18.36	115.94	37.	250.69	13.35	119.70
8.	291.14	15.03	125.57	23.	275.72	18.65	115.77	38.	249.55	11.78	122.38
9.	290.67	15.89	124.15	24.	273.35	18.49	115.55	39.	249.07	10.97	124.30
10.	290.02	17.30	122.38	25.	270.30	18.38	115.33	40.	248.73	10.16	125.50
11.	289.59	18.05	120.86	26.	268.94	18.32	115.16	41.	248.71	7.81	127.00
12.	289.07	18.86	119.44	27.	267.13	18.00	114.99	42.	247.32	7.34	128.50
13.	288.55	19.51	118.32	28.	264.97	17.39	114.86	43.	247.43	6.32	130.00
14.	287.95	19.46	117.71	29.	260.73	17.51	114.42	44.	247.08	4.97	132.00
15.	287.43	19.46	117.32	30.	258.53	17.24	114.95	45.	246.78	2.81	134.50
								46.	246.61	0.00	135.00

(Points 47-92 are the same as 45-1 with the sign of the y value changed)

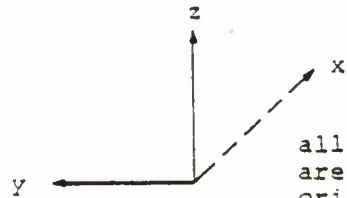

all Figs.  
are F,L,U  
orientation  
(COMBIMAN)

Figure 120. X, Y and Z Coordinates of A7E-01 Boundaries.

Directions of the x, y, and z axes are A for Aft, F for Forward, L for Left, R for Right, U for Up, and D for Down. CBMVM converts the given coordinates to the COMBIMAN coordinate system ( $x=F$ ,  $y=L$ ,  $z=U$ , and  $SRP=(0,0,0)$ ). (See Figure 120.)

The maximum number of vertices allowed for each panel of the crew station is 100. These vertices must be input consecutively, going either clockwise or counterclockwise along the perimeter of the panel as explained in Paragraph 6.3.2.1.

### 6.3.2 Processing Specification

The functions available to CBMVM users are the same as those for program CBMCM excluding the one to punch a member. The function request formats are punched one request per card and are shown in Figure 121. All control cards can be used anytime in any order except that the \$INT card must be the first control card to initialize or re-initialize the Data Base. The format and necessary parameters of the control cards are explained in the following paragraphs.

#### 6.3.2.1 ADD VISIBILITY MEMBER Function

&ADD membername type nbnds srpx srpy  
srpz x y z xx yy zz (followed by  
visibility member definition).

The ADD VISIBILITY MEMBER function adds the input data under the member name membername to the Visibility Data Base. The membername is limited to a length of eight characters. Type is a two-digit right justified integer that can be either 0 or 1. If  $type=0$ , the program checks the panel vertices for clockwise or counterclockwise entries.  $Type=1$  avoids this test. Nbnds is a right justified three-digit integer, which specifies the number of panels associated with a membername. The SRP coordinates are srpx,



srpy, and srpz and are entered as real numbers in F6.2 format. A decimal point, if omitted, is inserted by the program in between the second and third digits from the right. X, Y, and Z indicate the directions of the positive x, y, and z coordinates respectively, (A, F, L, R, U or D). xx, yy, zz are two letter abbreviations for the axis labels and directions of the input coordinate system when the operator is seated in the crew station. Examples of these values are FS (Fuselage Station-aft), WL (WaterLine-up), or BL (ButtLine-right).

Each panel is defined by a card containing its sequence number (seq.#), panelname, and number of coordinates (# coord) within the panel on one card and xyz coordinates of each vertex on separate cards. Figures 122 and 123 show the format for these input cards.

Seq.# and # coord are 3-digit right justified integers; the panelname can be up to 28 characters long. The three-dimensional coordinates of vertices are input as real numbers in F6.2 format, one set to a card. A decimal point, if omitted, is inserted between the second and the third digits from the right.

An example of the ADD VISIBILITY MEMBER function is shown in Figure 124. The first outlined area contains the &ADD control card. The associated panels consist of a panel name card (area 2) followed by the specified number of three-dimensional coordinate data cards shown in the third outlined area.

If the program detects an error in the input data the member will not be added to the Data Base.

\$ADD 17E-01 3 270.6 0.0 99.15 F L U FS 3L WL			
001WINDSCREEN, FRONT BOTTOM 17			
22763	584	12535	
22379	551	12324	
22098	546	12157	
21893	519	12059	
21579	486	11876	
21314	427	11735	
21109	362	11616	
20914	281	11584	
20914	000	11584	
20914	-281	11584	
21109	-362	11616	
21314	-427	11735	
21579	-487	11876	
21893	-519	12059	
22098	-546	12157	
22379	-551	12324	
22763	-584	12535	
002WINDSCREEN, FRONT TOP 17			
22763	584	12535	
23000	578	12665	
23212	568	12784	
23444	541	12903	
23731	470	13059	
23941	405	13173	
24109	292	13286	
24212	200	13341	
24212	000	13341	
24212	-200	13341	
24109	-292	13286	
23941	-405	13173	
23731	-470	13059	
23444	-541	12903	
23212	-568	12784	
23000	-578	12665	
22763	-584	12535	
003COCKPIT CANOPY CLEARLINE 1 92			
29447	000	13550	
29404	247	13460	
29361	622	13326	
29322	832	13201	
29261	1054	13024	
29209	1243	12858	
29162	1378	12700	
29114	1503	12557	
29067	1589	12415	
29002	1730	12238	
	.		
	.		
	.		
29209	-1243	12858	
29261	-1054	13024	
29322	-832	13201	
29361	-622	13326	
29404	-247	13460	
29447	000	13550	

1  
2  
  
3

Figure 124. Sample Data for \$ADD Member Function.

#### 6.3.2.2 CHECK VISIBILITY MEMBER Function

&CHK membername type nbnds srpx srpy srp  
x y z xx yy zz (followed by visibility  
crew station definition).

The CHECK VISIBILITY MEMBER function operates in the same way the ADD VISIBILITY MEMBER function does except that the member is not added, but is only checked for errors.

#### 6.3.2.3 DELETE VISIBILITY MEMBER Function

&DEL membername

The DELETE VISIBILITY MEMBER function removes a given membername from the Data Base. In order to make the space occupied by the deleted member available, COMPRESS VISIBILITY DATA BASE function must be used.

#### 6.3.2.4 COMPRESS VISIBILITY DATA BASE Function

&CMP

The COMPRESS VISIBILITY DATA BASE function compresses used space and maximizes the continuous unused space in the Visibility Data Base.

If the message "CBM527A NO SPACE, CANNOT ADD membername" is encountered during an &ADD operation, it is necessary to use compress function first and then attempt to add again. If the message reappears, the Data Base is full.

### 6.3.2.5 DUMP VISIBILITY MEMBER Function

&DMP membername or  
&DMP

The DUMP VISIBILITY MEMBER function prints the contents of the specified visibility member membername or by default prints the entire Visibility Data Base if no member name is specified. The format of the output is as follows:

```
RECORD nn
=== first half of record in EBCDIC ===
=== second half of record in EBCDIC ===
=== complete                               ===
===          record                        ===
===          in                            ===
===          Hexadecimal                   ===
```

where:

nn - is the sequence number of the record on the Data Base and

=== - is delimiter for the data.

This function is primarily used as a debugging aid for Input/Output errors.

### 6.3.2.6 PRINT VISIBILITY MEMBER Function

&PRT membername or  
&PRT

The PRINT VISIBILITY MEMBER function prints the data contained in the specified membername in a format similar to the input to the ADD VISIBILITY MEMBER function. Specifying no name or a nonexistent name causes a printout of the list of members and their extents on the Data Base, as well as the origin and orientations of their coordinate data.

#### 6.3.2.7 INITIALIZE VISIBILITY MEMBER Function

&INT

The INITIALIZE VISIBILITY MEMBER function is used primarily to establish a Data Base, although it may be used to return the data base to its original unused state.

#### 6.3.2.8 END PROGRAM Function

&END

The END PROGRAM function terminates execution of the program CBMVM.

### 6.3.3 Submitting a Processing Request

The sequence of Job Control Language (JCL) cards needed to execute the program CBMVM are shown in Figure 125. Initialization of the Data Base for the first time requires allocation of space on disk for the Data Base and is accomplished by the "//FT09F001 DD" cards shown in Figure 126 and the \$INT control card initializes the Data Base. The "//FT09F001 DD" card in Figure 125 is used for all subsequent processing requests. The &END control card is always the last control card and it ends the program CBMVM.

### 6.3.4 Output Data Interpretation

Output generated by the program CBMVM, which controls page formatting and identifies each page with the source program name (CBMVM), date, and time of program execution, and page number, falls into five format types.

```

00001000
00001100
00001200
00001300
00001400
00001500
00001600
00001700
00001800

```

```

//CBMVM      JCL HLSS
//JULIB      DD DSN=COMBIMAN.LOADLIB,DISP=SHR
//CBMVM      EXEC PGM=CBMVM
//FT05F001  UU DDNAME=SYSIN
//FT06F001  DD SYSOUT=A
//FT07F001  DD SYSOUT=B
//FT09F001  DD DSN=COMBIMAN.VISDATA,DISP=SHR
//SYSUDUMP  DD SYSOUT=A
//SYSIN     DD *

```

CBMVM FUNCTION CONTROL CARDS AND  
MEMBER DEFINITION DATA

```

/*
//
00001900

```

Figure 125. Job Control Cards to Execute CBMVM.

```

//FT09F001  DD DSN=COMBIMAN.VISDATA,UNIT=DISK,DISP=(NEW,CATLG),
//          VOL=SER=DISK01,SPACE=(240,2000),
//          DCH=(BLKSIZE=240,LRECL=240,RECFM=F8)
00001600
00001610
00001620

```

Figure 126. FT09F001 DD Card to Allocate Space for  
COMBIMAN.VISDATA and Execute Program  
CBMVM.

The first type of output is generated by the &INT, &CMP, &DEL and &END functions. The output for these functions indicates the start and end of processing associated with the specified function. The COMPRESS function, however, generates additional messages indicating that a certain member was, or was not, moved in the process of combining unused space. An example of this format, for the COMPRESS function, is shown in Figure 127.

The second type of output is generated by the PRINT function with a blank membername field. This causes a listing of the entries in the directory of the Data Base in the following format:

```

nn.) membername, EXTENT (n1, n2), nb PANELS,
      ORIGIN = (x,y,z), ORIENT = (a,b,c),
      AXES HEADINGS = (xx, yy, zz)

```

where:

<u>nn</u>	identifies the record number of the member within the directory
<u>membername</u>	is the 8 character name of the member at record nn
<u>n1</u>	is the location of first record of membername
<u>n2</u>	is the location of last record of membername
<u>nb</u>	is the number of panels associated with the member
x y z	is the location of the SRP in the original coordinate system
a b c	are the original orientation of the positive x, y and z axes, respectively.
xx yy zz	are the original axes headings for the positive x, y and z axes, respectively.

CBM5001 &CMP  
CBM5281 BI-NAV01 WAS IN PLACE.  
CBM5281 ATE-01 WAS IN PLACE.  
CBM5381 COMPRESS FINISHED.

Figure 127. A Sample Output of &CMP Function.

CBM5001 &PPT  
19.) BI-NAVIA, EXTENT=( 38, 46), 7 BOUNDARIES, ORIGIN=( 396.50, 22.00, 62.50), ORIENT.=(A,R,U)  
AXES HEADINGS =(IFS,BL,WL).  
20.) ATE-01 , EXTENT=( 31, 37), 3 BOUNCARIES, ORIGIN=( 270.60, 0.0 , 99.15), ORIENT.=(F,L,U)  
AXES HEADINGS =(IFS,BL,WL).  
21.) BI-NAV01, EXTENT=( 22, 30), 7 BOUNDARIES, ORIGIN=( 396.60, 22.00, 62.50), ORIENT.=(A,R,U)  
AXES HEADINGS =(IFS,BL,WL).

Figure 128. A Sample Output of &PRT Function.

This information was originally supplied to the Data Base by the &ADD control card. An example of the output of the &PRT function is shown in Figure 128.

The third type of output is generated by the DUMP function. For the member specified on the &DMP control card, the directory information in the second format is printed first. It is followed by records of the member printed in the format shown in Paragraph 6.3.2.5. The record in EBCDIC is printed in a 30A4 format and for the hexadecimal output, 15Z8 format is used.

The DUMP function is used primarily as a debugging aid for Input/Output errors. An example of the DUMP function output is shown in Figure 129.

The fourth output format is used by the CHECK and ADD functions. The first item printed out is a reformatting of the information on the control card. Then, each panel definition along with its input and absolute coordinates are printed. The format is:

```

nn.) bndnm,nv VERTICES - INPUT COORD--ABSOLUTE COORD--
      (x11, y11, z11) to (x21, y21, z21) " "
      " " " " " "
      (x1nv, y1nv, z1nv) to (x2nv, y2nv, z2nv)

```

where:

<u>nn</u>	is the panel sequence number
<u>bndnm</u>	is the boundary name (8 characters or less)
<u>nv</u>	is the number of vertices for the panel
x <sub>1i</sub> , y <sub>1i</sub> , z <sub>1i</sub>	coordinate of ith vertex of the panel in the original system of coordinates (i=1, nv)
x <sub>2i</sub> , y <sub>2i</sub> , z <sub>2i</sub>	coordinates of the ith vertex of the panel, converted to the COMBIMAN coordinate system (i=1, nv)



An example of the output generated by the &ADD function is shown in Figure 130.

The fifth and last format is used by the PRINT function output. In this output the original input coordinates are not printed. The directory information is printed first and is followed by the panel definition data.

nn.) bndnm, nv VERTICES -- ABSOLUTE COORDINATES

```
(x1, y1, z1)  "
      "          "          "
(xnv, ynv, znv)
```

where:

nn is the panel sequence number  
bndnm is the panel name (8 characters or less)  
nv is the number of vertices which constitute the panel

An example of this format is shown in Figure 131.

#### 6.4 PROGRAM MESSAGES - INCLUDING ERROR CORRECTION

The program CBMVM prints out information and action related messages. The message format is:

CBM5nni message text

where:

nn is the message number  
i indicates the action code (I=informational, A=action to be performed).  
message text is the text of the message.

```

CBM500) GAI/O A7E-01 3270.60 0.0 99.15 F L U FS BL HL
CBM519) MFMBER, A7E-01 , HAS 3 BOUNDARIES.
CBM520) COORDINATES ARE TRANSLATED TO ( 270.60, 0.0 , 99.15).
CBM521) COORDINATES GIVEN AS F, L AND U ARE NOW F, L, AND U.
CBM522) AXES HEADINGS ARE FS, HL AND WL.
      1.) WINDSCREEN, FRONT BOTTOM TYPE= 0 17 VERTICES --INPUT COORDINATES---
( 227.63 5.84 125.35) TO ( -42.97 5.84 26.20)
( 223.79 5.51 123.24) TO ( -46.81 5.51 24.09)
( 220.98 5.46 121.57) TO ( -49.62 5.46 22.42)
( 218.93 5.19 120.59) TO ( -51.67 5.19 21.44)
( 215.79 4.86 118.76) TO ( -54.81 4.86 19.61)
( 213.14 4.27 117.35) TO ( -57.46 4.27 18.20)
( 211.09 3.62 116.16) TO ( -59.51 3.62 17.01)
( 209.14 2.81 115.84) TO ( -61.46 2.81 16.69)
( 209.14 0.0 115.84) TO ( -61.46 0.0 16.69)
( 209.14 -2.81 115.84) TO ( -61.46 -2.81 16.69)
( 211.09 -3.62 116.16) TO ( -59.51 -3.62 17.01)
( 213.14 -4.27 117.35) TO ( -57.46 -4.27 18.20)
( 215.79 -4.87 118.76) TO ( -54.81 -4.87 19.61)
( 218.93 -5.19 120.59) TO ( -51.67 -5.19 21.44)
( 220.98 -5.46 121.57) TO ( -49.62 -5.46 22.42)
( 223.79 -5.51 123.24) TO ( -46.81 -5.51 24.09)
( 227.63 -5.84 125.35) TO ( -42.97 -5.84 26.20)
      2.) WINDSCREEN, FRONT TOP TYPE= 0 17 VERTICES --INPUT COORDINATES---
( 227.63 5.84 125.35) TO ( -42.97 5.84 26.20)
( 230.00 5.78 126.65) TO ( -40.60 5.78 27.50)
( 232.12 5.68 127.84) TO ( -38.48 5.68 28.69)
( 234.44 5.41 129.03) TO ( -36.16 5.41 29.88)
( 237.31 4.70 130.59) TO ( -33.29 4.70 31.44)
( 239.41 4.05 131.73) TO ( -31.19 4.05 32.58)
( 241.09 2.92 132.86) TO ( -29.51 2.92 33.71)
( 242.12 2.00 133.41) TO ( -28.48 2.00 34.26)
( 242.12 0.0 133.41) TO ( -28.48 0.0 34.26)
( 242.12 -2.00 133.41) TO ( -28.48 -2.00 34.26)
( 241.09 -2.92 132.86) TO ( -27.51 -2.92 33.71)
( 239.41 -4.05 131.73) TO ( -31.19 -4.05 32.58)
( 237.31 -4.70 130.59) TO ( -33.29 -4.70 31.44)
( 234.44 -5.41 129.03) TO ( -36.16 -5.41 29.88)
( 232.12 -5.68 127.84) TO ( -38.48 -5.68 28.69)
( 230.00 -5.78 126.65) TO ( -40.60 -5.78 27.50)
( 227.63 -5.84 125.35) TO ( -42.97 -5.84 26.20)
      3.) CHECKIT CAMDPI CLEARLINE TYPE= 1 92 VERTICES --INPUT COORDINATES---
( 294.47 3.0 135.50) TO ( 23.87 0.0 36.35)
( 294.04 2.47 134.60) TO ( 23.44 2.47 35.45)
( 293.61 6.22 133.26) TO ( 23.01 6.22 34.11)
( 293.22 0.32 132.01) TO ( 22.62 8.32 32.86)
( 292.61 10.54 130.24) TO ( 22.01 10.54 31.09)
( 292.09 12.43 128.60) TO ( 21.49 12.43 29.45)
( 291.62 13.78 127.00) TO ( 21.02 13.78 27.85)
( 291.14 15.03 125.57) TO ( 20.54 15.03 26.42)
( 290.67 15.89 124.15) TO ( 20.07 15.89 25.00)

```

Figure 130. A Sample Output of CBMVM &ADD Function.

```

CBM500) GPRT A7E-01
20.) A7E-01 , EXTENT=( 31, 37), J BOUNDARIES, ORIGIN=( 270.50, 0.0 , 99.15), ORIENT.=)F.L.U)
1.) WINDSCREEN, FRONT BOTTOM TYPE= 0 17 VERTICES --ABSOLUTE, COORDINATES--
( -42.97 5.84 26.20)
( -46.81 5.51 24.09)
( -49.62 5.46 22.42)
( -51.67 5.19 21.44)
( -54.81 4.86 19.64)
( -57.46 4.27 18.20)
( -59.51 3.62 17.01)
( -61.46 2.81 16.69)
( -61.46 0.0 16.69)
( -61.46 -2.81 16.69)
( -59.51 -3.62 17.01)
( -57.46 -4.27 18.20)
( -54.81 -4.86 19.64)
( -51.67 -5.19 21.44)
( -49.62 -5.46 22.42)
( -46.81 -5.51 24.09)
( -42.97 -5.84 26.20)
2.) WINDSCREEN, FRONT TOP TYPE= 0 17 VERTICES --ABSOLUTE, COORDINATES--
( -42.97 5.84 26.20)
( -40.60 5.78 27.50)
( -38.48 5.68 28.69)
( -36.16 5.41 29.88)
( -33.29 4.70 31.44)
( -31.19 4.05 32.58)
( -29.51 2.92 33.71)
( -28.48 2.00 34.26)
( -28.48 0.0 34.26)
( -28.48 -2.00 34.26)
( -29.51 -2.92 33.71)
( -31.19 -4.05 32.58)
( -33.29 -4.70 31.44)
( -36.16 -5.41 29.88)
( -38.48 -5.68 28.69)
( -40.60 -5.78 27.50)
( -42.97 -5.84 26.20)
3.) COCKPIT CANOPY CLEARLINE TYPE= 1 92 VERTICES --ABSOLUTE, COORDINATES--
( 23.47 0.0 36.35)
( 23.44 2.47 35.45)
( 23.01 6.22 34.11)
( 22.62 3.32 32.86)
( 22.01 13.54 31.09)
( 21.49 12.43 29.45)
( 21.02 13.78 27.85)
( 20.54 15.03 26.42)
( 20.07 15.89 25.00)
( 19.42 17.30 23.23)
( 18.99 18.05 21.71)
( 18.47 18.86 20.29)

```

Figure 131. A Sample Output of CBMVM &PRT Function.

CBM500I     control card image  
Reason:            User has submitted a control card.  
System Action:    Reads the control card.  
User Action:       None.

CBM501A     operation UNKNOWN OPERATION.  
Reason:            The operation on the control card  
                    (shown in the previous CBM500I  
                    message) is unknown.  
System Action:    This control card is ignored.  
User Action:       Correct the card and resubmit.

CBM503A     vertexnumber INVALID VERTEX NUMBER FOR POINT  
panelname.  
Reason:            The order in which the vertices are  
                    given is not in a clockwise or  
                    counterclockwise direction.  
System Action:    Vertex number 1 is used.  
User Action:       Delete the member, correct the error  
                    and resubmit.

CBM505A     NO NAME GIVEN, operation IGNORED.  
Reason:            This operation requires a member  
                    name, but none was supplied.  
System Action:    The operation is ignored.  
User Action:       Supply the member name and resubmit.

CBM506A     membername NOT FOUND.  
Reason:            For the Delete function (&DEL), Dump  
                    function (&DMP), or Print function  
                    (&PRT) the specified visibility  
                    member name does not exist.  
System Action:    The directory of the visibility data  
                    base is printed, instead of  
                    performing the requested function.  
User Action:       Check the control card for  
                    nonexistent member name.

CBM507A     NUMBER OF PANELS INVALID FOR MEMBER membername.  
Reason:            The number of panels as specified on  
                    the ADD function control card (&ADD)  
                    is either less than 1 or greater  
                    than 15.  
System Action:    The control card is ignored.  
User Action:       Correct and resubmit.

CBM508A     axis FOR X INVALID, MEMBER IS membername.  
Reason:            During the Add function (&ADD) the  
                    direction of the user's X-axis is  
                    not F, A, L, R, U or D.  
System Action:    The control card is ignored.  
User Action:       Correct and resubmit.

CBM509A axis FOR Y INVALID, MEMBER IS membername.  
Reason: During the Add function (&ADD), the direction of the user's Y-axis is not F, A, L, R, U or D.  
System Action: The control card is ignored.  
User Action: Correct and resubmit.

CBM510A axis FOR Z INVALID, MEMBER IS membername.  
Reason: During the Add function (&ADD), the direction of the user's Z-axis is not F, A, L, R, U or D.  
System Action: The control card is ignored.  
User Action: Correct and resubmit.

CBM511A X&Y, X&Z OR Y&Z ARE COLLINEAR FOR MEMBER membername.  
Reason: The directions of two axes are the same (ex. X=L, Y=U, and Z=U).  
System Action: The control card is ignored.  
User Action: Pick unique directions for the axes and resubmit.

CBM512A DIRECTORY IS FULL, CANNOT ADD membername.  
Reason: No space is left in the Visibility Data Base directory to add an entry for this member. The directory can hold only 20 membernames.  
System Action: The control card is ignored.  
User Action: Delete one or more members, compress the Data Base, and resubmit.

CBM514A membername ALREADY EXISTS.  
Reason: User has tried to add a member definition under a name that exists in the Data Base.  
System Action: The control card is ignored.  
User Action: Use a new name, and resubmit.

CBM515A END OF DATA.  
Reason: The end of file was found before the END Program control card (&END).  
System Action: The program is ended.  
User Action: Check to make sure that all the control cards are processed.

CBM516A I/O ERROR ON RECORD recordnumber (INDEX).  
Reason: An I/O error occurred on the Visibility Data Base.  
System Action: Terminates the program.  
User Action: Contact Systems Programmer.

CBM517A I/O ERROR ON RECORD recordnumber (DATA).  
Reason: An I/O error occurred on the Visibility Data Base.  
System Action: Terminates the program.  
User Action: Contact systems programmer.

CBM519I NEW MEMBER, membername, HAS nn PANELS.  
Reason: The user has added a member definition to the Data Base.  
System Action: The addition is accepted.  
User Action: None.

CBM520I COORDINATES ARE TRANSLATED TO seat reference point coordinate.  
Reason: The user added a member definition to the Data Base.  
System Action: The addition is accepted.  
User Action: None.

CBM521I COORDINATES GIVEN AS axis, axis AND axis ARE NOW F, L, and U.  
Reason: The user added a member definition to the Data Base.  
System Action: The addition is accepted.  
User Action: None.

CBM522I AXES HEADINGS ARE xx, yy, AND zz.  
Reason: The user added a member definition to the Data Base.  
System Action: The addition is accepted.  
User Action: None.

CBM523I membername DELETED.  
Reason: The user submitted a DELETE function control card (&DEL).  
System Action: The membername is deleted.  
User Action: None.

CBM524I INITIALIZED.  
Reason: The user requested that the Visibility Data Base be initialized using the Initialize Visibility Data Base Function (&INT).  
System Action: The Data Base is initialized.  
User Action: None.

CBM527A NO SPACE, CANNOT ADD membername.  
Reason: There is not enough space in the data base to hold the requested addition.  
System Action: The control card is ignored.  
User Action: Compress the Data Base and resubmit.

CBM528I membername WAS IN PLACE.  
Reason: The user requested the Data Base be compressed. The member, membername was already compressed, and not moved.  
System Action: The member was not moved.  
User Action: None.

CBM529I      membername NOW IN PLACE.  
Reason:            The user requested the Data Base be compressed, the member, membername was not in place, and therefore was moved.  
System Action:    The Data Base is compressed.  
User Action:       None.

CBM531A      panelname HAS SAME NUMBER AS panelname.  
Reason:            While adding a contour definition, two panels have the same panel number.  
System Action:    Both panels are accepted. Note that references to the second will cause a reference to the first.  
User Action:       Delete the member definition, correct the error, and resubmit.

CBM532I      PROGRAM END.  
Reason:            The End Program function control (&END) card, or an end of file is encountered, or there is an I/O error, or there is an unknown operation.  
System Action:    Terminates program.  
User Action:       Make sure that all control cards are accepted, and processed correctly.

CBM534I      membername WITH nn PANELS HAS BEEN ADDED.  
Reason:            Member has been successfully added.  
System Action:    Reads next control card.  
User Action:       None.

CBM535A      membername NOT ADDED DUE TO nn ERRORS.  
Reason:            During &ADD operation, the system found nn errors.  
System Action:    Reads next control card; member is not added.  
User Action:       Correct error and resubmit.

CBM536I      MEMBER membername CHECKED, nn ERRORS.  
Reason:            During &CHK, the system found nn errors.  
System Action:    Reads next control card.  
User Action:       Correct and resubmit.

CBM537A      DATA BASE IS NOT VISIBILITY DATA BASE.  
Reason:            First record in directory contains a keyword 'IVIS' to identify a Visibility Data Base. We accessed a data set without that keyword.  
System Action:    Terminates program.  
User Action:       Check JCL cards and access correct data set.

## APPENDIX A

### COMBIMAN DISTRIBUTION TAPE DOCUMENTATION

#### A. CONTENTS

COMBIMAN DISTRIBUTION TAPE IS AN IBM STANDARD LABEL, NINE TRACK, 16 COBPI, DENSITY=3, PARITY=CDD, IEHMOVE TAPE CONTAINING TVC PARTITIONED DATA SETS AND SIX SEQUENTIAL DATA SETS. THE VOLUME SERIAL FOR THE DISTRIBUTION TAPE IS CBMTPE. THE DATA CONTROL BLOCK PARAMETERS OF THE DATA SETS ARE DESCRIBED IN THE FOLLOWING TABLE.

DATASET	FILE	LRECL	RECFM	BLKSIZE	ORGANIZATION
COMBIMAN.TPDCCNNT	1	80	FB	3200	SEQUENTIAL
COMBIMAN.LCADLIB	2		U	13030	PARTITIONED
COMBIMAN.DSTRBSRC	3	80	FB	3200	PARTITIONED
COMBIMAN.ANTHDATA	4	248	FB	248	SEQUENTIAL
COMBIMAN.CRSTDATA	5	368	FB	368	SEQUENTIAL
COMBIMAN.INITDATA	6	150	V3S	3200	SEQUENTIAL
COMBIMAN.SMPLANTH	7	80	FB	3200	SEQUENTIAL
COMBIMAN.VISDATA	8	240	FB	240	SEQUENTIAL

THE FIRST FILE ON THE TAPE IS A SEQUENTIAL FILE AND CONTAINS THE DESCRIPTION OF THE DATA SETS ON THE TAPE AND THE INSTALLATION PROCEDURE IN CARD IMAGE FORMAT.

THE SECOND FILE CONTAINS THE LOAD MODULES CBM05, CBMAM, CBMCM, AND CBMVM AS MEMBERS OF THE PARTITIONED DATA SET COMBIMAN.LCADLIB. LINK EDIT MAPS OF THESE LOAD MODULES ARE GIVEN IN APPENDIX B-1, -2, -3, AND -4.

FILE 3 CONTAINS SOURCE MODULES CBMCP2, CBMCP3, CBMCP4, CBMVS1, CBM0FF, CBMCM, AND CBM0FF AS MEMBERS OF A PARTITIONED DATA SET COMBIMAN.DSTRBSRC. THE GRAPHIC SUBROUTINE CALLS IN CBMCP2, CBMCP3, CBMCP4, CBMVS1, AND IBMGLD ARE WRITTEN TO BE EXECUTED ON AN ON-LINE Gould 5000 ELECTROSTATIC PLOTTER. THE USERS MAY HAVE TO CHANGE THESE CODES AND COMPILE AND LINK EDIT THESE SUBROUTINES TO CBM05 TO USE THE PLOTTER AT THEIR SITE. CBM0FF, THE FIFTH MEMBER, IS THE OFFLINE PLOT ROUTINE. IT USES DATA GENERATED ON UNIT 11 DURING A COMBIMAN RUN WHEN PFK7 IS ACTIVATED TO GET AN OFF-LINE PLOT OF COMBIMAN. THE CODE IN CBM0FF MODULE IS WRITTEN FOR A CALCOMP PLOTTER DRIVEN BY A CDC COMPUTER. THE SIXTH MEMBER, CBMCM, HAS THE SOURCE LISTING OF THE MAIN ROUTINE WHICH MAINTAINS THE CREW STATION DATA BASE (CBMCDM). THIS MODULE MAY BE ALTERED TO SUIT THE DATA ENTRY OR DIGITIZING PROCEDURES AT THE USER'S FACILITIES TO ADD NEW CREW STATION DATA OR TO MODIFY EXISTING MEMBERS. THE SEVENTH MEMBER IN THE DATA SET IS THE SOURCE LISTING OF THE ASSEMBLER SUBROUTINE IBMGLD. IBMGLD IS CALLED FROM THE

SUBROUTINE GSPGLD TO CONVERT THE IBM 2250 GRAPHIC ORDERS TO GOULD TYPE PLCT ORDERS. LISTINGS OF THESE SOURCE MODULES ARE GIVEN IN APPENDIX C.

FILES 4 THROUGH 8 ARE SEQUENTIAL DATA SETS AND CONTAIN DATA NECESSARY TO EXECUTE CBMC5. IN FILE FOUR THE DATA SET COMBIMAN.ANTHDATA, DESCRIBED IN SECTION 4, HAS THE ANTHROPO-METRIC SURVEY AND REGRESSION DATA FOR 1967 USAF PILOTS, 1968 USAF WOMEN, 1968 USAF WOMEN FLYERS, 1964 US NAVY FLYERS, AND 1970 US ARMY PILOTS. THE JCL CARDS, PROGRAM CONTROL CARDS, AND DATA NECESSARY TO CREATE THIS DATA SET ARE LISTED IN APPENDIX D.

FILE 5 HAS THE COMBIMAN.CRSTDATA DATA SET WHICH CONTAINS THE SEAT, PANEL, AND CONTROL DATA FOR THE A7E-01 CREW STATION CONFIGURATION. THE JCL CARDS, CONTROL CARDS, AND DATA USED TO CREATE THIS DATA SET ARE IN APPENDIX E.

FILE 6 HAS THE DATA SET COMBIMAN.INITDATA WHICH CONTAINS DATA NECESSARY TO GENERATE THE COMBIMAN LINK SYSTEM AND PROMPTING MESSAGES.

FILE 7 HAS THE DATA SET COMBIMAN.SMPLANTH WHICH CONTAINS 18 SETS OF SAMPLE ANTHROPOMETRY FOR THE CARD INPUT OPTION OF THE INPUT 12 ANTHROPOMETRIC DIMENSIONS FUNCTION (SEE SECTION 2.2.12 AND FIGURE 40 OF THE USER'S GUIDE).

FILE 8 HAS THE DATA SET COMBIMAN.VISDATA WHICH CONTAINS THE VISIBILITY DATA (SEE SECTION 6 OF COMBIMAN USER'S GUIDE) FOR THE A7E-01 CREW STATION CONFIGURATION. THE JCL CARDS, CONTROL CARDS, AND DATA USED TO CREATE THIS DATA SET ARE IN APPENDIX F.

## B. INSTALLATION PROCEDURE

THE GENERAL PROCEDURE DESCRIBED HERE TO COPY A DATA SET FROM COMBIMAN DISTRIBUTION TAPE TO DISK CONSISTS OF TWO STEPS. THE FIRST STEP ALLOCATES SPACE FOR THE DATA SET TO DISK USING PGM=IEFBRI4. THE SECOND STEP COPIES THE DATA SET TO DISK USING PGM=IEHMOVE. THIS PROCEDURE IS SUGGESTED BECAUSE THE UTILITY IEHMOVE MAY NOT ALLOCATE SUFFICIENT SPACE TO LOAD LARGE DATA SETS.

```
//ALLOCATE JOB
//ALLOCC EXEC PGM=IEFBRI4
//DD1 DD DSN=COMBIMAN.TPDCCMNT,DISP=(NEW,CATLG,DELETE),
// SPACE=(TRK,(1,1)),UNIT=DISK,VOL=SER=VOLUME,
// DCB=(RECFM=FB,LRECL=80,BLKSIZE=3200)
//
```

THE 'VOLUME' IN VCL=SER=VOLUME SHOULD BE CHANGED TO REFLECT THE DISK VOLUME.

THE DCB PARAMETERS FOR ALL THE DATA SETS ARE GIVEN IN THE TABLE IN SECTION A OF THIS APPENDIX. THE SPACE PARAMETERS FOR THE DATA SETS ARE:

DATASET	SPACE PARAMETER
CCMBIMAN.TPDCCMNT	(TRK,(1,1))
CCMBIMAN.LOADLIB	(TRK,(20,10,5))
CCMBIMAN.SOURCE	(TRK,(5,1,2))
CCMBIMAN.ANTHDATA	(248,2000)
CCMBIMAN.CRSTDATA	(368,2000)
CCMBIMAN.INITDATA	(TRK,(1,1))
CCMBIMAN.SMPLANTH	(TRK,(1,1))
CCMBIMAN.VISDATA	(240,2000)

THE JCL TO COPY A PARTITIONED DATA SET, COMBIMAN.LOADLIB, FROM CBMTPE FILE 2 IS:

```
//COPYPDS JOB
//COPY EXEC PGM=IEHMCVE
//SYSPRINT DD SYSCUT=A
//SYSUT1 DD UNIT=SYSDA,SPACE=(TRK,(1,1)),DISP=CLD
//CBMTPE DD UNIT=TAPE,VCL=(PRIVATE,RETAIN,SER=CBMTPE),
// DISP=CLD
//CBMDSK DD UNIT=DISK,VCL=SER=VOLUME,DISP=CLD
//SYSIN DD *
COPY PDS=CCMBIMAN.LOADLIB,FRGM=TAPE=(CBMTPE,2),TO=DISK=VOLUME
/*
//
```

THE JCL TO COPY A SEQUENTIAL DATA SET, COMBIMAN.ANTHDATA, FROM CBMTPE FILE 4 IS:

```
//COPYSEQ JOB
//COPY EXEC PGM=IEHMCVE
//SYSPRINT DD SYSCUT=A
//SYSUT1 DD UNIT=SYSDA,SPACE=(TRK,(1,1)),DISP=CLD
//CBMTPE DD UNIT=TAPE,VCL=(PRIVATE,RETAIN,SER=CBMTPE),
// DISP=CLD
//CBMDSK DD UNIT=DISK,VCL=SER=VOLUME,DISP=CLD
//SYSIN DD *
COPY DSNAME=CCMBIMAN.ANTHDATA,FRGM=TAPE=(CBMTPE,4),
TC=DISK=VOLUME
/*
//
```

APPENDIX B-1

LINKAGE EDITOR MAP OF CBM05

```

//CBM05L JCB UCRI,PAPU,CLASS=C          JUB 40
//LKED EXEC PGM=LLWL,REGION=120K,      00001100
//      PARM=LIST,LIST,MAP,SIZE=1120K,20K)* 00001200
//SYSLIB CC DSN=SYS1.FORTLIB,DISP=SHR    00001300
//      CC DSN=SYS1.LINKLIB,DISP=SHR     00001400
//      CO DSN=SYS1.FESFURT,DISP=SHR    00001500
//SYSLIB DD UNIT=SYSDA,SPACE=1729*,(20,20),RLSE), 00001600
//      DCB=BLKSIZE=7294                00001700
//CFMCLB DD DSN=CCMBIMAN.OBJECT,DISP=SHR 00001800
//SYSPRINT DD SYSOUT=A                  00001900
//SYSLMCO DD DSN=CCMBIMAN.LOADLIB,DISP=ULD 00002000
//SYSLIN DD *                           00002100
    
```

```

F-R-LEVEL LINKAGE EDITOR OPTIONS SPECIFIED LIST,LIST,MAP,SIZE=1120K,20K)
VARIABLE OPTICAS USED -- SIZE=1122880,20480)
    
```

IEW0000	ENTRY	CEMRTS	00002200
IEW0000	INCLUDE	SYSLIB(THCGSP03)	00002300
IEW0000	INCLUDE	SYSLIB(SYMBOL,LINE,NUMBER,AXIS,SCALC,PLUIS,RTSTN48)	00002400
IEW0000	INCLUDE	CBMLIB(CBMAID,CBMAIM,CBMAJX,CBMLP1,CBMCP2,CBMCP3,	100002500
IEW0000	INCLUDE	CBMCP4,CBMCRS,CBMCNV,CBMLRN,CBMCSI,CBMCVA,CBMDAT,	200002600
IEW0000	INCLUDE	CBMDLP,CBMDPL,CBMDSP,CBMENF,CBMENV,CBMENI,CBMGQA,	300002700
IEW0000	INCLUDE	CBMIDP,CBMIND,CBMINT,CBMINTL,CBMINTJ,CBMJCT,CBMCPN,	400002800
IEW0000	INCLUDE	CBMYLT,CBMPEF,CBMPEK,CBPLN,CBMPNL,CBMPRT,CBMPS,	500002900
IEW0000	INCLUDE	CBMPST,CBPFCH,CBMRPY,CBMKPL,CBMRST,CBMRIS,CBMSSH,	600003000
IEW0000	INCLUDE	CBMTOL,CBFTNG,CBTRM,CBVIS,CBHVSI,CBMXCC,CBMXHR,	700003100
IEW0000	INCLUDE	CBZMM,CRTDMP,USPCLE,IBMGCDD)	00003200
IEW0000	NAME	(PROSIF)	00003300

MIDDLE MAP

CONTROL SECTION			ENTRY		NAME				LOCATION			
NAME	ORIGIN	LENGTH	NAME	LOCATION	NAME	LOCATION	NAME	LOCATION	NAME	LOCATION	NAME	LOCATION
IHCUSPC3	00	15C	INDEV	00	IMDEV	4	INGDS	8	IMGDS	C		
			GRATL	10	ENATL	14	ENATN	18	DSATN	1C		
			MPATL	20	MLPEU	24	SLPAT	28	MLITS	2C		
			KQATN	30	EURATL	34	SETATN	38	SALRM	3C		
			GSPRD	40	RCURS	44	ICURS	48	SDATM	4C		
			SGKAM	50	SJATL	54	SGDSL	58	SSCIS	5C		
			SCHAM	60	PLINE	64	PPNT	68	PSGMT	6C		
			PTEXT	70	STPUS	74	MVPU5	78	BGSLQ	7C		
			HGSLB	80	ENSEQ	84	MVPU5	88	LKSUB	8C		
			INCL	90	OMIT	94	EXEC	98	KESET	9C		
			IDPCS	A0	F5MOD	A4	STEOS	A8	GRGDS	AC		
			LUCPN	B0	BGTRK	B4	ROTAK	B8	ENTRK	BC		
			DFSTR	C0	PLSIR	C4	DRGEN	C8	CNVRT	CC		
			ITRC	D0	ITBP	D4	RTBP	D8	ITST	DC		
			SPEC	E0								
SYMBOL	160	9E0	WIDTH	56A								
LINE	840	184										
NUMBER	CC8	1AC										
AXIS	E08	534										
SCALE	13A0	23C										
PLIPLCTS	15D0	F7C										
PLIPT4E	2540	58C	PLCTS	15D0	FACTOR	1924	ERASE	1958	CLSOUT	1988		
PLIBITST	2AC0	189C	WHERE	1980	LINEMT	19E8	LISTON	1A36	NOLIST	1A48		
			OFFSET	1A5A	RESRV	1A88	PLOTT	1AC8	PLUT	1BA6		
			GUSERR	2040								
PLIPT4E	2540	58C	PLUOCT	2548	PLUOUI	27C0						
PLIBITST	2AC0	189C	RITSET	2AD0	BITSETL	2AE4	BITRESRV	2AF4				
P2INR2	467C	URC	RITINIT	4670	RIFURMAT	4676	BUFINIT	469A				

NAME	ORIGIN	LENGTH	NAME	LOCATION	NAME	LOCATION	NAME	LOCATION	NAME	LOCATION	NAME	LOCATION
CRJMP	3FC30	118	ALG10	4C57C	IH\$ALUG0	40570	LOG10	40570	IH\$ALUG	40588		
GSPGLD	3FL48	38C	ALUG	4C588	LOG	40588						
IBMGLD	400CD	498	MAX1	40748	MIN1	4075E	AMAX1	40774	AMINI	4078A		
IHC5LUG *	40570	104	ARCCS	4C830	ACUS	40830	IH\$ARCUS	40830	ARSIN	40846		
			ASIN	4C84C	IH\$ARSIN	40846						
IHC\$MAXP*	40748	E5	ATAN2	4CA2B	IH\$ATAN2	40A28	ATAN	40A3C	IH\$ATAN	40A3C		
IHC\$ASCN*	40E30	1F7	CUS	40C10	IH\$\$CUS	40C10	SIN	40C32	IH\$\$SIN	40C32		
IHC\$ATN2*	40A28	1E8	DI CCS#	4CE18								
IHC\$SCN *	40C10	20E	FRXPR#	41000								
IHC\$EDICS*	40E18	EE2	IBCCM#	41ECC	IB081971	41ECC	FDIOCS#	41F88	INTSWICH	42C88		
IHC\$FRXPR*	41CG0	198	APC81971	431C4								
IHC\$ECCM#*	41EAG	E8C	SEQCASD	43802								
FICAP# *	42C5C	6F4	SQRT	43E10	IH\$SQRT	43E10						
IHC\$GMP2*	43448	9C5	BCNV	43F78								
IHC\$SCRT*	43F10	168	DEBLG#	44230								
IHC\$GPC4*	43F78	288	EXP	44A38	IH\$\$EXP	44A38						
IHC\$BUC *	44230	801	FRXPI#	448E8								
IHC\$EXP *	44A38	18C	ERRMCN	44D68	IHOERRE	44D80						
IHC\$FRXPI*	44E8	175	INGSP	455C8								
IHC\$PRM *	44E68	624	TMGSP	45A70								
IHC\$ATEL*	45390	638	ADCCN#	45EFO	FCVAUUTP	45C9A	FCVLUUTP	45D2A	FCVZOUTP	45E86		
IHC\$GPC1*	455C8	A2	FCVLUUTP	46260	FCVLUUTP	46352	FCVLUUTP	46352	INT6SWCH	465B4		
IHC\$GPC2*	45A7C	EA	AR11F#	46638	ADJ\$SWICH	468CC						
WAITU *	45E60	8C	FIULS#	46F38	FIUC\$BEP	46E3F						
IHC\$CVTH*	45PFU	A42										
IHC\$FNTH*	46E38	80C										
IHC\$EDICS*	46E38	118C										
IHC\$EDICS2*	47FC8	642										
IHC\$OPT *	48E1U	33E										

NAME	ORIGIN	LENGTH	NAME	LOCATION	NAME	LOCATION	NAME	LOCATION
CEPAJC	5420	CCB						
CBPASM	6CF8	140A						
CBMBCX	74F8	81E						
CBMCP1	7E18	AFE2						
CBMCP2	12C00	7E2						
CBMCP3	134E8	2648						
CBMCP4	15F30	614						
CBMGN5	16148	2F6						
CBMGNV	16440	20C						
CBMGRW	16640	128C						
CBMCSI	176CC	892						
CBMGVW	18158	6RA						
CBMCAT	18618	FE						
CBMDEP	18518	1C8F						
CBMGDL	1A5A8	4FC						
CBMUSP	1AA98	40CC						
CBMUNF	1EE68	F8F						
CBMLNV	1FE28	28C6						
RDIST	223F0	19A						
DLINE	22550	19A						
CBMENI	22730	C1C						
CBMGQA	23340	37E						
CBMIDP	236E8	84C						
CBMIND	24208	402F						
CBMINT	28238	19CF						
CBMINI	29C08	2810						
CBMIOI	2C718	8C8						
CBMJOI	2D2E0	84C						
CBMLPN	2DE28	20E						
CBMPLT	2DC38	3FE						
CBMPEF	2E138	742						
CBMPEK	2E8B0	25C						
CBMPLN	2E7E0	1C3C						
CBMPLN	30718	832						
CBMPRT	30F50	6CA						
CBMPSP	31E20	63F						
CBMPSI	32160	31E						
CBMPCF	32480	1F5C						
CBMRPY	343E0	626						
CBMRPI	344C8	292						
CBMPSI	34CC0	32AC						
CBMRTS	37F60	72C						
CBMSSK	38688	5FE						
CBMTBL	38C80	934						
CBMTNG	395E2	E7C						
CBMTRM	3A43E	384						
CBMVIS	3A7C0	26A6						
CBMXCL	3C168	164E						
CBMXCL	3E4E8	21E						
CBMXHR	3E7A8	1E8						
CBMZMM	3F790	49A						

NAME	ORIGIN	LENGTH	NAME	LOCATION	NAME	LOCATION	NAME	LOCATION
IHCFCUNI*	48548	2FC	FJCCNI#	48548				
IHCFCGCU*	48C48	4C2	FJCCNC#	48C48				
IHCETRCH*	49110	2AE	IHOTRCH	49110	ERRTRA	49118		
IHCFTEN *	493CC	15P	FTEN#	493CC				
CBMRGR	49553	4D78						
CBMKEN	4E2D0	184						
CBMJLI	4E488	1EC						
CBMDM	4E668	19B4						
CBMELN	50C2C	4C						
CBMRCA	50C60	AD8						
CBMVSH	50E38	4E5C						
CBMGRA	55588	8E						
CBMPDT	55A10	2C						
CBMXYZ	55A30	65CC						
CBMBXY	58F30	410C						
CBMDAV	60C30	C						
CBMVEW	60C40	CP						
CBMBDS	601C8	284E						
CBMRIV	62950	PRR						

ENTRY ADDRESS 37FCJ  
TOTAL LENGTH 63508

\*\*\*CBM05 DUES NOT EXIST BUT HAS BEEN ADDED TO DATA SLT

APPENDIX B-2  
LINKAGE EDITOR MAP OF CBMAM

```

//CBAMLND JOB UDRI,BAPU
//LKFD EXEC PGM=IEHL,PARM=(LIST,MAP)
//SYSLIB DD DSN=SYS1.FORTLIB,DISP=SHR
//CMLIB DD DSN=CCBMAIN.OBJECT,DISP=SHR
//SYSPRINT DD SYSUCL=A
//SYSLMCU DD DSN=CCBMAIN.LOADLIB,DISP=SHR
//SYSUT1 DD UNIT=SYS0A,SPACE=(1024,1200,200)
//SYSLIN DD *
    
```

```

JUL 17
00000200
00000300
00000400
00000500
00000600
00000700
00000800
    
```

```

F88-LEVEL LINKAGE EDITOR OPTIONS SPECIFIC LIST,MAP
DEFAULT OPTION(S) USED -- SIZE=192160,8192)
IEW0000 ENTRY CEMAM
IEW0000 INCLUDE CEMLIB,CBMAIN,CBMADP,CBMCAT)
IEW0000 NAME CEMAN(R)
    
```

```

00000900
00001000
00001100
    
```

MODULE MAP

CONTROL SECTION			ENTRY			MODULE MAP		
NAME	ORIGIN	LENGTH	NAME	LOCATION	NAME	LOCATION	NAME	LOCATION
CBMADP	0J	64C0	DIUCS#	6880	FDIUCS#	7850	INTSWTCH	8550
CBMADP	64C0	25C	IBCCM#	7794	IB081971	7794		
CBMCAT	6720	15C	AP081971	8A8C				
IFCEDICS*	6880	EE2	SEQCASD	90CA				
INCECLM#	7768	EBC	ADCGN#	96D8	FCVADUTP	9782	FCVLOUTP	996E
FILEP# *	6618	6F4	FCVIOUTP	9D48	FCVVEOUTP	9E3A	FCVZOUTP	996E
IHCCGMFZ*	8C10	9C5					INT6SWCH	A09C
IHLFCVTH*	96E8	A43						

IHCFFATH#	A120	800						
IHCFFATH#	A120	800						
IHCFFATH#	A920	118C						
IHCFFATH#	A920	642						
IHCFFATH#	BABC	024						
IHCFFATH#	C0F8	938						
IHCFFATH#	C720	338						
IHCFFATH#	CE58	2FC						
IHCFFATH#	UC90	402						
IHCFFATH#	U390	2AF						
IHCFFATH#	0552	198						
IHCFFATH#	U008	2C						
IHCFFATH#	U0A0							

ENTRY ADDRESS 00  
TOTAL LENGTH 0000

\*\*\*CEMAN DOES NOT EXIST BUT HAS BEEN ADDED TO DATA SET

APPENDIX B-3  
LINKAGE EDITOR MAP OF CBMCM

```

//CBMCMK0 JOB UJRI,BAPU
//LKLO EXEC PGM=IEHL,PARM=ILISI,MAPJ
//SYSLIB DD DSN=SYSL.FURTLIB,DISP=SHR
//CBMLIB DD DSN=LLMUMMAN.URJECT,DISP=SHR
//SYSPRINT DD SYSOUT=A
//SYSLMCD DD DSN=CCMBIMAN.LGAOLIB,DISP=SHR
//SYSLIN DD UNIT=SYSUA,SPACE=(1224,1200,200)
//SYSLIN DD *
    
```

```

F33-LEVEL LINKAGE EDITOR OPTIONS SPECIFIED LIST,MAP
DEFAULT (PTIONS) USED -- SIZE=192160,8192)
IEH0000 ENTRY CBMCDM 00000900
IEH0000 INCLUDE CBMLIBCBMCM,CBMCDP,CBMOT3,CBMOT4,CBMTRN) 00001000
IEH0000 NAME CB4CMTR) 00001100
    
```

MODULE MAP

CONTROL SECTION			ENTRY				MODULE MAP			
NAME	ORIGIN	LENGTH	NAME	LOCATION	NAME	LOCATION	NAME	LOCATION	NAME	LOCATION
CBMCM	00	E700	DI0CS#	F418						
CBMCDP	E700	24C	IUCGM#	1032C	LU081971	1032C	F010CS#	103E8	INTSWTCH	110E8
CBMDAT	E950	15C	AP081971	11624						
CBMDT3	EABD	224	SECCASO	11C62						
CBMDT4	EC08	494	SQRT	12270	IH\$SQRI	12270				
CBMTRN	F170	2A2	ADCGN#	12308	FCVAUTP	12482	FCVLUUTP	12512	FCVZUUTP	1266E
IPCEJICS*	F418	EE2	FCVLUUTP	12A48	FCVEGUTP	1283A	FCVCOUTP	1283A	INT6SWCH	1209C
IHCCECMH*	1D300	EDC								
FICAP#	* 11180	6F4								
IHLCPM2*	118AB	9C5								
IHCSSORT*	12270	168								
IHFVCTH*	123D8	A43								

IMLEFNTH*	12E20	800	ARIHA	12E20	ADJSTNTH	133B4
IMCFICS*	13620	118C	FIDCS#	13620	FIDCSDEP	13626
IMCFICS2*	147B0	642	ERRMON	14DF8	IHCERRL	14E10
IMCFHRP*	14DF8	624	FOCCNI#	15090		
IMCUATEL*	15420	630	FUGCND#	16090		
IMCUOPT*	15A58	33E	IHUTRCH	16558	ERRTRA	16560
IMCFCCNI*	15C50	2FC	FTEN#	16808		
IMFCUNG*	16C50	4C2				
IMCETRCH*	16558	2AE				
IMUFTEN*	16808	198				
CBMWDG	169A0	2C				

ENTRY ADDRESS 00  
TOTAL LENGTH 169C0

\*\*\*CMCP UCES NOT EXIST BUT HAS BEEN ADDED TO DATA SET

APPENDIX B-4  
LINKAGE EDITOR MAP OF CBMVM

```

//CBMVMEND JOB COKI,CAPU
//LKED EXEC PGM=LINKL,PARM=LIST,MAPI
//SYSLIB DD DSN=SYSL.FORTLIB,DISP=SHR
//CENLIB DD DSN=CUMBIIMAN.OBJECT,DISP=SHR
//SYSPRINT DD SYSUT=A
//SYSLPDD DD DSN=CUMBIIMAN.LCADLIB,DISP=SHR
//SYSDIAG DD UNIT=SYSOA,SPACE=11024,(200,200)
//SYSLIN DD *
    
```

```

F88-LEVEL LINKAGE EDITOR OPTIONS SPECIFIED LIST,MAP
DEFAULT OPTIONS USED - SIZE=192160,8192)
IEW0000 ENTRY CBMVM
IEW0000 INCLUDE CPMLIRCBMVM,CBMVDP,CBMDAT)
IEW0000 NAME CBMVM(RI
    
```

```

00000900
00001000
00001100
    
```

MGULLE MAP

CCATRCCL SECTION			ENTRY					
NAME	ORIGIN	LENGTH	NAME	LOCATION	NAME	LOCATION	NAME	LOCATION
CBMVM	00	7EE4	DIUCS#	E2B8	F01UCS#	9288	INTSWTCH	9F88
CBMVPDP	7EE8	27C	IRCC4#	51CC	I80BL971	91CC		
CBMPCAT	8158	15C	APGE1571	A4C4				
INCLCITS*	82B8	EE2	SEQDASU	AB02				
INCECCLPH*	91A0	EBC	A0CCN#	B110	FCVAUUTP	B1BA	FCVLOUTP	B3A6
FILEAP#	* AC50	6F4	FCVIGUTP	B780	FCVEOUTP	B872	INT6SWCH	BAU4
INCCUPP2*	A748	9C5						
INCECVTH*	B110	A43						



APPENDIX C-1  
 COMBIMAN SOURCE - CBMCP2 LISTING

```

SUBROUTINE CBMCP2(X,Y)                                00001000
C                                                     00001100
C * * * * *                                           00001200
C                                                     00001300
C   CBMCP2 - PLOTS MAN-MODEL AND CREW STATION ON GOULD PLOTTER 00001400
C                                                     00001500
C   CALLED BY -                                         00001600
C     CBMCP1 - MAIN COMBIMAN PLOT ROUTINE              00001700
C     CBMCP4 - HEADING PLOT ROUTINE                   00001800
C                                                     00001900
C   CALLS -                                             00002000
C     PLCT   - CALCCMP ROUTINE (DRAW LINE)            00002100
C     SYMBOL - GOULD CHARACTER PLOT ROUTINE          00002200
C                                                     00002300
C   OUTPUT TO -                                         00002400
C     UNIT 9 - PLOTTER DATA                          00002500
C                                                     00002600
C   PAPAMETERS -                                       00002700
C     X - ARRAY OF X VALUES TO BE PLOTTED          00002800
C     Y - ARRAY OF Y VALUES TO BE PLOTTED          00002900
C                                                     00003000
C * * * * *                                           00003100
C                                                     00003200
C   COMMON // CEMBXZ // MAN-MODEL XYZ DATA            00003300
C     PROJECTED ENFLESHMENT ELLIPSOID SURFACE POINTS - XYZ. 00003400
C     INDEX ARRAY TO DEFINE RELATIONSHIP BETWEEN POINTS AND 00003500
C     LINKS.                                           00003600
C     INDEX ARRAY TO XYZ'S TO LOCATE TANGENT LINE ENDCENTS. 00003700
C   INTEGER XYZK                                       00003800
C   COMMON /CEMBXZ/ XYZEN(3,1000),XYZK(1000),MINTAN(2,40), 00003900
C   1   MAXTAN(2,40)                                   00004000
C                                                     00004100
C   COMMON // CBMXYZ // MAN-MODEL AND WORKSPACE XYZ DATA 00004200
C     MAN-MODEL JOINT AND ELLIPSE CENTERS (NEUTRAL AND     00004300
C     PROJECTED).                                         00004400
C     WORKSPACE PANEL XYZ DATA.                         00004500
C     KEY TO WXYZ ARRAY - IDENTIFYING EACH POINT WITH A PANEL. 00004600
C     MAX NUMBER OF XYZ'S, WORKSPACE-XYZ'S, KEYS, CONTROL 00004700
C     POINTS ALLOWED.                                    00004800
C     NUMBER OF LINKS, KEYS, XYZ'S, LINK-XYZ'S, WORKSPACE- 00004900
C     XYZ'S, CONTROLS, AND DIMENSIONS.                  00005000
C     KEYS AND CONTROL POINTS.                          00005100
C     CONTROL POINT DATA.                              00005200
C     STATE SWITCH ARRAY.                               00005300
C                                                     00005400
C   INTEGER WXYZK,CTLTYP,CTLPNL,CTLPNT,BLANKS,CTLNAM    00005500
C   COMMON /CEMXYZ/ XYZC(3,40,2),XYZ(3,40),WXYZ(3,750),WXYZK(750), 00005600
C   1   MAXXYZ,MAXW,MAXKEY,MAXCTL,NLNKS,MSGXI(2),ISRVI(2),MSGX(2), 00005700
C   2   ISRVI(2),MSGY(2),IKKSP(2),MSGZ(2),ITASK(2),     00005800
C   3   KEYS(6,250),CTLNAM(2,150),                    00005900
C   4   CTLTYP(150),CTLXYZ(5,150),CTLPNL(150),CTLPNT(150), 00006000
C   5   BLANKS(3),NKEY,WXYZ,NDIM,NLXYZ,NWXYZ,NCTL,ICSP,INPT, 00006100
C   6   ISW(72)                                         00006200
C                                                     00006300
C   DIMENSION X(1),Y(1)                                00006400
C   INTEGER BLANK,HIER(20)                             00006500
C   EQUIVALENCE (BLANK,BLANKS(1))                    00006600
C                                                     00006700
C   IF (ISW(13).EQ.1.AND.NKEY.GT.NLNKS) GO TO 55      00006800
C -----                                             00006900
C   PLOT MAN-MODEL LINKS AND CREW STATION             00007000
C -----

```

J = IABS(KEYTAB(5,1))	00007100
HIER(J) = 1	00007200
CALL PLCT(X(1),Y(1),3)	00007300
DC 50 I=2,NLNKS	00007400
J = IABS(KEYTAB(5,1))	00007500
K = KEYTAB(1,I)	00007600
HIER(J) = 1	00007700
-----	
C            DISPLAY ONLY HEAD AND NECK LINKS IF ISW(3)=0 (OFF)	00007800
C            IF((ISW(3).EQ.0.AND.(I.LE.5.OR.I.GE.11)).AND.ISW(5).EQ.0)	00007900
*            GC TO 20	00008000
-----	
C            LOCATE COORDINATE OF PREVIOUS POINT IN THE CHAIN	00008100
C            L = HIER(J-1)	00008200
CALL PLCT(X(L),Y(L),3)	00008300
10          M = 2	00008400
-----	
C            CHECK IF THE LINE IS IN OMIT OR INCLUDE STATUS	00008500
C            IF (KEYTAB(5,1).LT.0.AND.KEYTAB(6,1).LT.0) M=3	00008600
CALL PLCT(X(I),Y(I),M)	00008700
20          J = IABS(KEYTAB(6,1))	00008800
IF (J.EQ.1) GO TO 50	00008900
-----	
C            PLOT ENFLESHED MAN-MODEL	00009000
C            30    KP = KEYTAB(1,I)+NLNKS-1	00009100
L1 = KP+KEYTAB(6,1)-2	00009200
C            35    DC 45 L2=KP,L1	00009300
CALL SYMBOL(X(L2)-.04,Y(L2),.175,1F.,0.0,1,.175,0)	00009400
45          CONTINUE	00009500
C            IF(MINTAN(1,1).EQ.0) GO TO 50	00009600
L1 = MINTAN(1,1)+NLNKS	00009700
L2 = MINTAN(2,1)+NLNKS	00009800
CALL PLCT(X(L1),Y(L1),3)	00009900
CALL PLCT(X(L2),Y(L2),2)	00010000
L1 = MAXTAN(1,1)+NLNKS	00010100
L2 = MAXTAN(2,1)+NLNKS	00010200
CALL PLCT(X(L1),Y(L1),3)	00010300
CALL PLCT(X(L2),Y(L2),2)	00010400
50          CONTINUE	00010500
-----	
C            PLOT CREW STATION PANELS	00010600
C            55    CONTINUE	00010700
IF (NLNKS.EQ.NKEY) RETURN	00010800
I1 = NLNKS+1	00010900
C            DC 80 I=I1,NKEY	00011000
K = KEYTAB(1,I)+NXYZ+NLNKS	00011100
CALL PLCT(X(K),Y(K),3)	00011200
M = 2	00011300
IF (KEYTAB(5,1).LT.0.AND.KEYTAB(6,1).LT.0) M=3	00011400
J = IABS(KEYTAB(6,1))	00011500
L = K+1	00011600
K = K+J-1	00011700
C            00011800	00011800
00011900	00011900
00012000	00012000
00012100	00012100
00012200	00012200
00012300	00012300
00012400	00012400
00012500	00012500
00012600	00012600
00012700	00012700
00012800	00012800
00012900	00012900
00013000	00013000
C            00013100	00013100

	DC 60 J=L,K	00013200
	60 CALL PLCT(X(J),Y(J),M)	00013300
C		00013400
	30 CONTINUE	00013500
C		00013600
	RETURN	00013700
	END	00013800

APPENDIX C-2  
COMBIMAN SOURCE - CBMCP3 LISTING

```

C * * * * * 00001000
C 00001100
C CBMCP3 - WRITES COMBIMAN DATA FOR OFF-LINE PLOT ON UNIT 11 00001200
C 00001300
C CALLED BY - 00001400
C CEMCPI - MAIN COMBIMAN PLOT ROUTINE 00001500
C 00001600
C OUTPUT TO - 00001700
C UNIT 11 00001800
C 00001900
C * * * * * 00002000
C 00002100
C SUBROUTINE CBMCP3(DX,DY,SCALE,XZ01,XZ03,IEC,IPERSP) 00002200
C 00002300
C INTEGER ICX(2000) 00002400
C REAL CX(1),DY(1) 00002500
C 00002600
C 00002700
C COMMON // CBMBXY // MAN-MODEL XYZ DATA 00002800
C PROJECTED ENFLESHMENT ELLIPSOID SURFACE POINTS - XYZ. 00002900
C INDEX ARRAY TO DEFINE RELATIONSHIP BETWEEN POINTS AND 00003000
C LINKS. 00003100
C INDEX ARRAY TO XYZ'S TO LOCATE TANGENT LINE ENDPPOINTS. 00003200
C INTEGER XYZK 00003300
C COMMON /CEMXY/ XYZEN(3,1000),XYZK(1000),MINTAN(2,40), 00003400
1 MAXTAN(2,40) 00003500
C 00003600
C COMMON // CBMVEW // MAN-MODEL AND WORKSPACE DISPLAY DATA 00003700
C ROLL, PITCH, AND YAW DATA. 00003800
C MAGNIFICATION LEVEL. 00003900
C XYZ DISPLAY OFFSETS. 00004000
C RANGE OF VALUES IN X,Y,Z DIRECTION. 00004100
C MAXIMUM RANGE. 00004200
C MINIMUM AND MAXIMUM X,Y,Z VALUES. 00004300
C OMEGA TRANSFORMATION MATRIX. 00004400
C REAL MAGLVL 00004500
C COMMON /CBMVEW/ ROLL,PITCH,YAW,MAGLVL,DGFFX,DCFFY,OCFFZ,X0,Y0,Z0, 00004600
1 D0,XM,YM,ZM,XC,YC,ZC,MSGV(19),OMEGA(3,3),NGFF, 00004700
2 OMEGA,CFFSET(3) 00004800
C 00004900
C COMMON // CBMXYZ // MAN-MODEL AND WORKSPACE XYZ DATA 00005000
C MAN-MODEL JOINT AND ELLIPSE CENTERS (NEUTRAL AND 00005100
C PROJECTED). 00005200
C WORKSPACE PANEL XYZ DATA. 00005300
C KEY TO WXYZ ARRAY - IDENTIFYING EACH POINT WITH A PANEL. 00005400
C MAX NUMBER OF XYZ'S, WORKSPACE-XYZ'S, KEYS, CONTRCL 00005500
C POINTS ALLOWED. 00005600
C NUMBER OF LINKS, KEYS, XYZ'S, LINK-XYZ'S, WORKSPACE- 00005700
C XYZ'S, CONTRCLS, AND DIMENSIONS. 00005800
C KEYTAB BOOKKEEPING ARRAY. 00005900
C CONTROL POINT DATA. 00006000
C STATE SWITCH ARRAY. 00006100
C 00006200
C INTEGER WXYZK,CTLTYP,CTLPNL,CTLPNT,BLANKS,CTLNAM 00006300
C COMMON /CEMXYZ/ XYZC(3,40,2),XYZ(3,40),WXYZ(3,750),WXYZK(750), 00006400
1 MAXXYZ,MAXW,MAXKEY,MAXCTL,NLINKS,MSGX1(2),LRSRV(2),MSGX(2), 00006500
2 ISRVY(2),MSGY(2),IWKSP(2),MSGZ(2),ITASK(2), 00006600
3 KEYTAB(6,250),CTLNAM(2,150), 00006700
4 CTLTYP(150),CTLXYZ(5,150),CTLPNL(150),CTLPNT(150), 00006800
5 BLANKS(3),NKEY,NXYZ,NCIM,NLXYZ,NWXYZ,NCTL,ICSP,INPT, 00006900
6 ISW(72) 00007000
C 00007000

```

	INTEGER PVIEW	00007100
C	IEC = 0	00007200
	PVIEW = OMEGA(1,2)+LMEGA(2,3)+2	00007300
	TEMP = ABS(RCLL)+ABS(PITCH)+AES(YAW)	00007400
	IF(TEMP.NE.0.) PVIEW=4	00007500
	N = ISW(25)	00007600
C	PLCT NUMBER	00007700
	MAXD = NXYZ+NWXYZ+NLNKS	00007800
	WRITE(11,1000) MAXD,NWXYZ,NKEY,NLNKS,NXYZ,SCLC,XZD1,XZD3,N,IPERSP	00007900
C	DC 20 I=1,MAXD	00008000
	IDX(I) = DX(I)*100.	00008100
20	CONTINUE	00008200
	WRITE(11,1001) (IDX(I),I=1,MAXD)	00008300
C	DC 25 I=1,MAXD	00008400
	IDX(I) = DY(I)*100.	00008500
25	CONTINUE	00008600
	WRITE(11,1001) (IDX(I),I=1,MAXD)	00008700
	WRITE(11,1001) (KEYTAB(1,I),I=1,NKEY)	00008800
	WRITE(11,1001) (KEYTAB(5,I),I=1,NKEY)	00008900
	WRITE(11,1001) (KEYTAB(6,I),I=1,NKEY)	00009000
C	DC 50 I=1,2	00009100
	WRITE(11,1002) (MINTAN(I,J),J=1,NLNKS)	00009200
	WRITE(11,1002) (MAXTAN(I,J),J=1,NLNKS)	00009300
50	CONTINUE	00009400
C	WRITE(11,1003) ISRV,ISRVY,IWKSP	00009500
	WRITE(11,1004) PVIEW,RCLL,PITCH,YAW	00009600
	WRITE(11,1005)	00009700
	RETURN	00009800
C	-----	00009900
C	FORMAT STATEMENTS	00010000
C	-----	00010100
	1000 FORMAT(I4,2I3,I2,I4,F4.2,2F7.2,2I2)	00010200
	1001 FORMAT(16I5)	00010300
	1002 FORMAT(20I4)	00010400
	1003 FORMAT(20A4)	00010500
	1004 FORMAT(I2,3F10.2)	00010600
	1005 FORMAT(4F999)	00010700
	END	00010800
		00010900
		00011000
		00011100
		00011200
		00011300

APPENDIX C-3  
COMBIMAN SOURCE - CBMCP4 LISTING

```

C * * * * * 00001000
C 00001100
C CBMCP4 - PLOTS HEADINGS AND DEFINES BOUNDARIES FOR 00001200
C PLOTS OF MAN MODEL AND CREW STATION ON 00001300
C GCULO PLOTTER (INTERMEDIATE ROUTINE) 00001400
C 00001500
C CALLED BY - 00001600
C CBMCP1 - MAIN COMBIMAN PLOT ROUTINE 00001700
C 00001800
C CALLS - 00001900
C CBMCP2 - PLOTS MAN-MODEL AND CREW STATION ON GCULO 00002000
C CLSCUT - FREE BUFFER (GCULO) 00002100
C NUMBER - PLOT NUMBER (GOLLD) 00002200
C PLCT - GENERAL PLOT (GCULO) 00002300
C PLCTS - INITIALIZE PLOTTER (GOLLD) 00002400
C SYMBCL - PLOT SYMBOL (GOLLD) 00002500
C 00002600
C OUTPUT TO - 00002700
C SYSPLCT - GCULO PLOTTER 00002800
C 00002900
C PARAMETERS - 00003000
C OX(3000) ARRAY OF SCALED X COORDINATES 00003100
C DY(3000) ARRAY OF SCALED Y COORDINATES 00003200
C SCLE - PLOT SCALE FACTOR 00003300
C IX - REAL WORLD COORD. ALIGNED WITH X SCREEN COORD. 00003400
C IY - REAL WORLD COORD. ALIGNED WITH Y SCREEN COORD. 00003500
C 00003600
C * * * * * 00003700
C 00003800
C SUBROUTINE CBMCP4(CX,OY,SCLE,IPERSP) 00003900
C 00004000
C DIMENSION XZD(3),DX(1),DY(1) 00004100
C INTEGER MSG(3),IVIEW(5),MSG1(5),ELANK 00004200
C 00004300
C COMMON // CBMBXY // MAN-MODEL XYZ DATA 00004400
C PROJECTED ENFLESHMENT ELLIPSOID SURFACE POINTS - XYZ. 00004500
C INDEX ARRAY TO DEFINE RELATIONSHIP BETWEEN POINTS AND 00004600
C LINKS. 00004700
C INDEX ARRAY TO XYZ'S TO LOCATE TANGENT LINE ENDCENTS. 00004800
C INTEGER XYZK 00004900
C COMMON /CBMBXY/ XYZEN(3,1000),XYZK(1000),MINTAN(2,40), 00005000
1 MAXTAN(2,40) 00005100
C 00005200
C COMMON // CBMVEW // MAN-MODEL AND WORKSPACE DISPLAY DATA 00005300
C ROLL, PITCH, AND YAW DATA. 00005400
C MAGNIFICATION LEVEL. 00005500
C XYZ DISPLAY OFFSETS. 00005600
C RANGE OF VALUES IN X,Y,Z DIRECTION. 00005700
C MAXIMUM RANGE. 00005800
C MINIMUM AND MAXIMUM X,Y,Z VALUES. 00005900
C OMEGA TRANSFORMATION MATRIX. 00006000
C REAL MAGLVL 00006100
C COMMON /CBMVEW/ ROLL,PITCH,YAW,MAGLVL,DCFFX,DCFFY,DCFFZ,XU,YU,ZO, 00006200
1 UC,XM,YM,ZM,XC,YC,ZC,MSGV(19),OMEGA(3,3),NCOFF, 00006300
2 OMEGA,COFFSET(3) 00006400
C 00006500
C COMMON // CBMXYZ // MAN-MODEL AND WORKSPACE XYZ DATA 00006600
C MAN-MODEL JOINT AND ELLIPSE CENTERS (NEUTRAL AND 00006700
C PROJECTED). 00006800
C WORKSPACE PANEL XYZ DATA. 00006900
C KEY TO XYZ ARRAY - IDENTIFYING EACH POINT WITH A PANEL. 00007000

```

```

C          MAX NUMBER OF XYZ'S, WORKSPACE-XYZ'S, KEYS, CONTROL      00007100
C          POINTS ALLOWED.                                           00007200
C          NUMBER OF LINKS, KEYS, XYZ'S, LINK-XYZ'S, WORKSPACE-    00007300
C          XYZ'S, CONTROLS, AND DIMENSIONS.                          00007400
C          KEYTAB BOOKKEEPING ARRAY.                                 00007500
C          CONTROL POINT DATA.                                     00007600
C          STATE SWITCH ARRAY.                                     00007700
C          INTEGER WXYZK,CTLTYP,CTLPNL,CTLPNT,BLANKS,CTLNAM         00007800
C          COMMON /CEMXYZ/ XYZC(3,40,2),XYZ(3,40),WXYZ(3,750),WXYZ(750), 00007900
1          MAXXYZ,MAXW,MAXKEY,MAXCTL,NLNKS,MSGX1(2),IRSRV(2),MSGX(2),00008000
2          IRSRV(2),MSGY(2),WKSP(2),MSGZ(2),ITASK(2),              00008100
3          KEYTAB(6,250),CTLNAM(2,150),                          00008200
4          CTLTYP(150),CTLXYZ(5,150),CTLPNL(150),CTLPNT(150),    00008300
5          BLANKS(3),NKEY,NXYZ,NDIM,NLXYZ,NWXYZ,NCTL,ICSP,INPT,    00008400
6          ISW(72)                                                  00008500
C
C          EQUIVALENCE (XZD(1),XD)                                  00008600
C          EQUIVALENCE (BLANK,BLANKS(1))                            00008700
C
C          DATA IVIEW,'XY ', 'XZ ', 'YZ ', 'CFF ', 'AXIS' /        00009000
C          DATA MSG/4HVIEW,+H-PLA,4HNE: /                          00009100
C          DATA MSG1/4HROLL,4H P,4HITCH,4H YAW /                   00009200
C          NCH = 4                                                  00009300
C
C          NUMBER OF CHARACTERS TO BE DISPLAYED                     00009400
C          PVIEW = OMEGA(1,2)+CMEGA(2,3)+2                          00009500
C          TEMP = ABS(ROLL) + ABS(PITCH) + ABS(YAW)                 00009600
C          IF(TEMP.NE.0) PVIEW=4                                    00009700
C          IF(PVIEW.EQ.4) NCH=8                                     00009800
C
C-----
C          PLOT TITLE                                              00010000
C-----
C          CALL PLOTS(5.,10.)                                       00010100
C          SIZE OF PLOT                                           00010200
C          CALL SYMBCL(1.,1.75,.25,MSGX1(1),90.,16.,.25,0)         00010300
C          REGRESSION MEMBER                                       00010400
C          CALL SYMBCL(1.5,1.75,.25,MSGX(1),90.,16.,.25,0)         00010500
C          SURVEY MEMBER                                           00010600
C          CALL SYMBCL(2.0,2.,.25,MSGY(1),90.,16.,.25,C)          00010700
C          CREW STATION MEMBER                                     00010800
C          CALL SYMBCL(2.5,1.,.25,MSG(1),90.,12.,.25,0)           00010900
C          VIEW PLANE:                                             00011000
C          CALL SYMBCL(999.,999.,.25,IVILW(PVIEW),90.,NCH,.25,C)  00011100
C          VIEW XY, XZ, YZ OR CFF AXIS                             00011200
C          CALL SYMBCL(3.0,1.5,.25,MSG1(1),90.,20.,.25,C)         00011300
C          ROLL, PITCH, AND YAW                                    00011400
C          CALL NUMBER(3.5,2.25,.25,ROLL,90.,1,2)                 00011500
C          ROLL ANGLE IN DEGREES                                  00011600
C          CALL NUMBER(3.5,4.25,.25,PITCH,90.,1,2)               00011700
C          PITCH ANGLE IN DEGREES                                 00011800
C          CALL NUMBER(3.5,6.5,.25,YAW,90.,1,2)                   00011900
C          YAW ANGLE IN DEGREES                                   00012000
C          IF (IPERSP.EQ.1) CALL SYMBCL(4.,1.75,.25,15HNON-PERSPECTIVE, 00012100
*          90.,15)                                                00012200
C          IF (IPERSP.EQ.2) CALL SYMBCL(4.,2.25,.25,11H-PERSPECTIVE, 00012300
*          90.,11)                                                00012400
C          CALL SYMBCL(4.5,2.25,.25,CFSCL=,90.,6)                 00012500
C          CALL NUMBER(999.,999.,.25,SCL,90.,2)                   00012600
C          SCALE                                                  00012700
C          CALL FLGT(0.,0.,999)                                    00012800
C          TERMINATE TITLE PLOT                                    00012900
C          CALL PLOTS(-60.,-60.)                                   00013000

```

C		START COMBIMAN PLCT	00013200
	CALL CBMCF2(DX(1),DY(1))		00013300
C		PLCT MAN-MODEL AND CREW STATION	00013400
	CALL PLOT(0.,0.,999)		00013500
C		TERMINATE COMBIMAN PLOT	00013600
	CALL CLSGLT		00013700
C		CLOSE FILE AND FREE CORE	00013800
	RETURN		00013900
	END		00014000



IF (1PLOT.EQ.9999) GO TO 300	00006200
C CLOSE PLOTTER AND TERMINATE PLOTTING	00006300
IF (1PLOT.NE.1) GO TO 200	00006400
C PLOT POINTS ALONG CONTOUR	00006500
-----C	00006600
C DEFINE SIZE OF PLOT TO BE 19X10	00006700
-----C	00006800
C CALL PLOTS(19.,10.)	00006900
-----C	00007000
C DRAW LEFT MARGIN	00007100
-----C	00007200
CALL PLOT(.05,0.,3)	00007300
CALL PLOT(.05,10.,2,3)	00007400
CALL PLOT(1.,0.,-3)	00007500
-----C	00007600
C PRINT HORIZONTAL & VERTICAL HEADINGS	00007700
-----C	00007800
CALL SYMBCL(.2,2.6,.3,16)VERTICAL DEGREES,90.,16)	00007900
CALL SYMBCL(.5,3.3,.2,16)FROM LINE-OF-SIGHT,90.,18)	00008000
CALL SYMBCL(3.25,.5,.3,37)HORIZONTAL DEGREES FROM LINE-OF-SIGHT,	00008100
1 0.,37)	00008200
-----C	00008300
C OUTLINE AREA OF PLOT	00008400
-----C	00008500
CALL PLOT(1.2,1.5,3)	00008600
CALL PLOT(1.2,8.8,2,-1)	00008700
CALL PLOT(15.6,8.8,2,-1)	00008800
CALL PLOT(15.6,1.6,2,-1)	00008900
CALL PLOT(1.1,1.6,2,-1)	00009000
-----C	00009100
C DRAW VERTICAL GRID	00009200
-----C	00009300
XC = 15.6	00009400
A = 1.1	00009500
YC = 1.6	00009600
DO 100 I=1,17 ,2	00009700
YC = YC+.4	00009800
CALL PLOT(A,YC,3)	00009900
CALL PLOT(XC,YC,2,1)	00010000
IF (1.EQ.17) GO TO 100	00010100
IF (1.EQ.15) XC=13.6	00010200
IF (1.EQ.15) A=3.2	00010300
YC = YC+.4	00010400
CALL PLOT(XC,YC,3)	00010500
CALL PLOT(A,YC,2)	00010600
100 CONTINUE	00010700
-----C	00010800
C DRAW HORIZONTAL GRID	00010900
-----C	00011000
XC = 1.2	00011100
YC = 7.6	00011200
DO 110 I=1,35,2	00011300
XC = XC+.4	00011400
IF (1.EQ.5) YC=3.3	00011500
CALL PLOT(XC,1.5,3)	00011600
CALL PLOT(XC,YC,2,1)	00011700
IF (1.EQ.35) GO TO 110	00011800
XC = XC+.4	00011900
IF (1.EQ.31) YC=7.6	00012000
CALL PLOT(XC,YC,3)	00012100
CALL PLOT(XC,1.5,2)	00012200

```

110 CONTINUE
C-----C
C          PUT LEGENDS ON THE PLCT
C-----C
A = .075
A1 = 13.8
CALL SYMBCL(13.75,8.6,.1,13HVISION LIMITS,0.,13)
CALL SYMBCL(A1,8.29,A,23HS - STEREO ,C.,23)
CALL SYMBCL(A1,8.11,A,23HF - FIXATION ,C.,23)
CALL SYMBCL(A1,7.93,A,23HP - PERIPHERAL ,C.,23)
CALL SYMBCL(A1,7.75,A,23HM - MAXIMUM PERIPHERAL ,C.,23)
CALL SYMBCL(1.5,8.6,.1,12HEYE LOCATION,0.,12)
CALL SYMBCL(1.75,8.45,.075,4HX = ,C.,4)
CALL NUMBER(2.05,8.45,.075,XLEYE,C.,2)
CALL SYMBCL(1.75,8.30,.075,4HY = ,C.,4)
CALL NUMBER(2.05,8.30,.075,YLEYE,C.,2)
CALL SYMBCL(1.75,8.15,.075,4HZ = ,C.,4)
CALL NUMBER(2.05,8.15,.075,ZLEYE,C.,2)
CALL SYMBCL(1.3,7.95,.085,13HCREW STATION:,C.,13)
CALL SYMBCL(2.405,7.95,.085,1NAME(1),C.,4)
CALL SYMBCL(2.745,7.95,.085,1NAME(2),C.,4)
CALL SYMBCL(1.675,7.75,.075,5HDATE:,C.,5)
CALL NUMBER(999.,999.,.075,1MCNTH,C.,-1)
CALL SYMBCL(999.,999.,.075,1H/,C.,1)
CALL NUMBER(999.,999.,.075,1DAY ,C.,-1)
CALL SYMBCL(999.,999.,.075,1H/,C.,1)
CALL NUMBER(999.,999.,.075,1YEAR ,C.,-1)
C-----C
C          LABEL VERTICAL AXIS
C-----C
YC = 1.5
IY = 90
DC 130 I=1,7
XC = .65
IYP = 1AES(IY)
IF (IYP.LT.10) XC=XC+.15
CALL NUMBER(XC,YC,.15,IYP,0.,-1)
CALL SYMBCL(999.,999.,.15,4C,C.,-1)
CALL SYMBCL(999.,999.,0.,1H0,C.,1)
YC = YC+1.2
IF (YC.GT.8.7) GO TO 140
IY = IY-30
130 CONTINUE
C-----C
C          LABEL HORIZONTAL AXIS
C-----C
140 CONTINUE
XC = 1.3
J = 210
DC 150 I=1,13
YC = .9
J = J-30
L = 1ABS(J)
IF (L.LT.100) YC=YC+.15
IF (L.LT.10) YC=YC+.15
CALL NUMBER(XC,YC,.15,L,90.,-1)
CALL SYMBCL(999.,999.,.15,4C,90.,-1)
CALL SYMBCL(999.,999.,0.,1HC,90.,1)
XC = XC+1.2
150 CONTINUE

```

```

00012300
00012400
00012500
00012600
00012700
00012800
00012900
00013000
00013100
00013200
00013300
00013400
00013500
00013600
00013700
00013800
00013900
00014000
00014100
00014200
00014300
00014400
00014500
00014600
00014700
00014800
00014900
00015000
00015100
00015200
00015300
00015400
00015500
00015600
00015700
00015800
00015900
00016000
00016100
00016200
00016300
00016400
00016500
00016600
00016700
00016800
00016900
00017000
00017100
00017200
00017300
00017400
00017500
00017600
00017700
00017800
00017900
00018000
00018100
00018200
00018300

```

```

C-----C
C          PRINT ORIENTATION OF THE CREWMEMBER'S HEAD
C-----C
      IHA = HANG+SIGN(.5,HANG)
C          HORIZONTAL ANGLE
      IHS = 1
C          SWITCH TO INDICATE SIGN OF IHA
C          1 FOR NEGATIVE, 2 FOR ZERO, AND
C          3 FOR POSITIVE
      IF (IHA .GT. 0.0) IHS=3
      IF (IHA .EQ. 0.0) IHS=2
      IF (IHA .LT. 0.0) IHA=-IHA
      IVZ = VANG+SIGN(.5,VANG)
C          VERTICAL ANGLE
      IVS = 1
C          SWITCH TO INDICATE SIGN OF IVA
      IF (IVA .GT. 0.0) IVS=3
      IF (IVA .EQ. 0.0) IVS=2
      IF (IVA .LT. 0.0) IVA=-IVA
C          RESET VERTICAL ANGLE
      ITL = 58+IHL(IHS)+IVL(IVS)
      IF (IHA.LT.10) ITL=ITL-1
      IF (IVA.LT.10) ITL=ITL-1
      TSP = (15.-(ITL*.2))/2.+8
C
      CALL SYMBCL(TSP,9.,.2,30HCREWMEMBERS HEAD IS POINTING ,C.,30)
      CALL NUMBER(999.,999.,.2,IHA,C.,-1)
      CALL SYMBCL(999.,9.12,.12,2HC ,0.,2)
      CALL SYMBCL(999.,9.,.2,IHT(1,IHS),0.,IHL(IHS))
      CALL SYMBCL(999.,999.,.2,12HFORWARD AND ,C.,12)
      CALL NUMBER(999.,999.,.2,IVA,C.,-1)
      CALL SYMBCL(999.,9.12,.12,2HC ,0.,2)
      CALL SYMBCL(999.,9.,.2,IVT(1,IVS),0.,IVL(IVS))
      CALL SYMBCL(999.,999.,.2,10HHORIZONTAL ,C.,10)
      CALL PLOT(1.2,1.6,-3)
      CALL SYMBCL(7.2,3.0,.15,1,C.,-1)
C-----C
C          GENERATE VISION LIMIT ELLIPSES
C          SSS... FOR STEEPC,
C          FFF... FOR FIXATION,
C          PPP... FOR PERIPHERAL, AND
C          MMM... FOR MAXIMUM PERIPHERAL VISIONS
C-----C
      DC 17C I=1,4
      A = AB(1,1)
      X1 = -A
      LIM = IFIX(A)+1
C
      DC 16C J=1,LIM
      SQ1 = SQRT(1.-(X1/A)**2)
      A1 = AB(2,1)*SQ1
      A2 = AB(3,1)*SQ1
      X11 = (X1+180.)*.04
      Y11 = (A1+90.)*.04
      Y21 = (A2+90.)*.04
      CALL SYMBCL(X11,Y11,.0675,IELIPS(1),C.,1,.1,1)
      CALL SYMBCL(X11,Y21,.0675,IELIPS(1),C.,1,.1,1)
      X1 = X1+2.
      16C CONTINUE
C
      17C CONTINUE

```

```

C-----C
C          PLCT POINTS ALONG CONTOUR
C          THE POINTS ARE PLCTED IN THE REGION DEFINED BY X---X
C
C                      (12.3,7.125)
C          X-----X
C          I          I          I          I
C          I          I          B          I
C          X-----X          I  B  I          X-----X
C          I  (2,5.525)  S  I          I  L          I
C          I          I  S          L          I          I
C          I          V  I          P L O T          T  Y  I
C          I          V          P L O T          T  Y  I
C          I          I          I
C          X-----X
C          (0,0)                      (0,14.3)
C-----C
200 CONTINUE
IPEN = 3
DC 230 I=1,NPNTS
XC = ALPH(I)*.04
YC = BETA(I)*.04
IF (I.EQ.1) GO TO 210
A = ABS(ALPH(I)-ALPH(I-1))
A1 = (ALPH(I)+ALPH(I-1))/2
A2 = (BETA(I)+BETA(I-1))/2
IF (A.GE.35.) IPEN=3
IF (A1.LT.1. .OR. A1.GT.359. .OR.
*   A2.LT.1. .OR. A2.GT. 179.) IPEN=3
C          SEGMENTS DISTORTED BEYOND REASON
C          ARE NOT PLOTTED
210 CONTINUE
IBNDRY = 0
C          SET BOUNDARY SWITCH TO 0
IF (XC.LT.0..OR.XC.GT.14.3..OR.YC.LT.0..OR.YC.GT.7.125)
*   IBNDRY=1
IF ((XC.LT.2.0..OR.XC.GT.12.3)..AND.YC.GT.5.525)
*   IBNDRY=1
IF (IBNDRY.EQ.0) CALL PLCT(XC,YC,IPEN)
C          PLCT POINTS WITHIN BOUNDARY ONLY
IPEN = 2
IF (IBNDRY.EQ.1) IPEN=3
230 CONTINUE
RETURN
C-----C
C          END PLOTTER ROUTINES
C-----C
300 CONTINUE
CALL PLOT(C.,0.,999)
CALL CLSCLT
RETURN
END

```

```

00024500
00024600
00024700
00024800
00024900
00025000
00025100
00025200
00025300
00025400
00025500
00025600
00025700
00025800
00025900
00026000
00026100
00026200
00026300
00026400
00026500
00026600
00026700
00026800
00026900
00027000
00027100
00027200
00027300
00027400
00027500
00027600
00027700
00027800
00027900
00028000
00028100
00028200
00028300
00028400
00028500
00028600
00028700
00028800
00028900
00029000
00029100
00029200
00029300
00029400
00029500
00029600

```

APPENDIX C-5  
 COMBIMAN SOURCE - CBMOFF LISTING

```

C      00001000
C      CBMOFF- TAKES DATA OFF OF TAPE TO BE USED TO PLOT COMBIMAN--OFFLINE 00001100
C      00001200
C      00001300
C      00001400
C      CALLS -
C      PLOTS - CALCOMP ROUTINE (PLOT INITIALIZATION) 00001500
C      PLOT - CALCOMP ROUTINE (DRAW LINE OR POSITION THE PEN) 00001600
C      NEWPEN - CALCOMP ROUTINE (CHANGE THE PEN COLOR) 00001700
C      FACTR - CALCOMP ROUTINE (RESET PLOT SCALE FACTOR) 00001800
C      SYMBOL - CALCOMP ROUTINE (DRAW A SYMBOL, CHARACTER, OR A 00001900
C      CHARACTER STRING) 00002000
C      NUMBER - CALCOMP ROUTINE (DRAW A NUMBER) 00002100
C      CBMCP0 - PLOT THE MAN MODEL AND CREW STATION 00002200
C      PLOTE - CALCOMP ROUTINE (CLOSE THE PLOT FILE) 00002300
C      00002400
C      INPUT FROM -
C      UNIT 5 - CARD INPUT 00002500
C      UNIT 8 - PLOT DATA ON DISK OR MAGNETIC TAPE OR CAROS 00002700
C      00002800
C      OUTPUT TO -
C      UNIT 6 - PRINTER 00002900
C      UNIT 7 - PLOT TAPE 00003000
C      00003100
C      00003200
C      00003300
C      REAL OX(2000),OY(2000) 00003400
C      COMMON/DUMMY/ MSGX1(2), IRSRV(2), MSGX(2), IRSRV(2), MSGY(2), IWKSP(2) 00003500
C      DIMENSION IPLOT(2),DATA(1024) 00003600
C      COMMON/CBMXYZ/ KEYTAB(3,250),NLNKS,MINTAN(2,40),MAXTAN(2,40), 00003700
C      1 NKEY,NXYZ,ICOLOR(4),FLESH,FACTR,SCLE 00003800
C      00003900
C*** THE INPUT STREAM CONSISTS OF
C      1. THE NAMELIST "CNTRL", EVEN IF IT'S EMPTY 00004100
C      2. A CARD WITH THE NUMBERS OF THE PLOTS NOT WANTED 00004200
C      00004300
C      ALSO;THE PLOT DATA FILE SHOULD BE ATTACHED TO THE PROGRAM AS 00004400
C      UNIT 8. 00004500
C      00004600
C      THE NAMELIST VARIABLES AND THEIR DEFAULT VALUES 00004700
C      1...FACTR= SCALE FACTOR FOR PLOT (DEFAULT=THAT SPECIFIED DURING 00004800
C      CBM05 RUN) 00004900
C      2...LINKS= 0, IF LINK SYSTEM IS TO BE PLOTTED; 1, IF NOT (DEF=0) 00005000
C      3...FLESH= 0, IF ENFLESHMENT ELIPSOIOS ARE TO BE PLOTTED; 1, IF 00005100
C      NOT (DEF=0) 00005200
C      4...CRST= 0, IF CREW STATION IS TO BE PLOTTED; 1, IF NOT (DEF=0) 00005300
C      5... (ICOLOR(I), I=1,4)= PEN COLORS FOR BANNER, LINK SYSTEM, 00005400
C      ENFLESHMENT ELIPSOIOS, AND CREW STATION RESPECTIVELY 00005500
C      (DEF=1, 1, 2, 3) 00005600
C      00005700
C      DIMENSION MSG1(3),MSG2(3),MSG3(3),MSG4(3),MSG5(6),IVIEW(5) 00005800
C      INTEGER FLESH,CRST,PVIEW 00005900
C      NAMELIST /CNTRL/ FACTR,LINKS,FLESH,CRST,ICOLOR 00006000
C      DATA FACTR,LINKS,FLESH,CRST/99.,3*0/ 00006100
C      DATA ENO/4H-999/,IPCNT/0/ 00006200
C      DATA MSG1/4H ,4HREGR,4HESS!/, MSG2/4H ,4H SUR,4HVEY!/, 00006300
C      1 MSG3/4H ,4H C,4HRST!/, MSG4/4H VIE,4H W=PL,4HANE!/, 00006400
C      2 MSG5/3H R,4HOLL,4H PI,4HTCH,4H Y,4HAM / 00006500
C      DATA IVIEW/4HXY ,4HXZ ,4HYZ ,4HOFF,4HAXIS/ 00006600

```

ICOLOR(1)=1	00006700
ICOLOR(2)=1	00006800
ICOLOR(3)=2	00006900
ICOLOR(4)=3	00007000
READ(5,CNTRL)	00007100
WRITE(6,CNTRL)	00007200
C	00007300
C READ IN PLOT NUMBERS FOR THOSE NOT WANTED(IN ANY ORDER)	00007400
READ(5,8C) (IPLOT(I),I=1,20)	00007500
80 FORMAT(20(1X,I2))	00007600
C	00007700
C	00007800
C PLOT INITIALIZATION FOR OFFLINE CALCOMP PLOT	00007900
CALL PLOTS(DATA,1024,7)	00008000
C	00008100
C	00008200
C MOVE THE PEN TO THE -Y LIMIT SWITCH(PEN PLOTTER ONLY)	00008300
CALL PLOT(0,-2,-3)	00008400
C	00008500
C	00008600
C SET THE MARGIN	00008700
CALL PLOT(1,1,-3)	00008800
C	00008900
IPC=0	00009000
C	00009100
C*** ROUTINE TO CHECK IF PLOT IS WANTED	00009200
C	00009300
5 IPCNT=IPCNT+1	00009400
DO 145 ICHECK=1,20	00009500
IF(IPCNT.NE.IPLOT(ICHECK)) GO TO 145	00009600
C SKIP PLOT DATA SUBFILE	00009700
140 READ(8,90) DATA01	00009800
IF(EOF(8))130,141	00009900
141 IF(DATA01.NE.END) GO TO 140	00010000
WRITE(6,153) IPCNT	00010100
150 FORMAT(1X,9HPLOT SET ,I2,28H WAS NOT PLOTTED--BY REQUEST)	00010200
GO TO 5	00010300
145 CONTINUE	00010400
IPC=IPC+1	00010500
C	00010600
C*** ROUTINE FOR READING DATA OFF TAPE	00010700
C	00010800
READ(8,10) MAX0,NWXYZ,NKEY,NLNKS,NXYZ,SCLE,X0,Y0,N,IPERSP	00010900
IF(EOF(8))130,12	00011000
10 FORMAT(I4,2I3,I2,I4,F4.2,2F7.2,2I2)	00011100
12 READ(8,30) (DX(I),I=1,MAX0)	00011200
READ(8,30) (DY(I),I=1,MAX0)	00011300
30 FORMAT(16F5.2)	00011400
READ(8,35) (KEYTAB(1,I),I=1,NKEY)	00011500
READ(8,35) (KEYTAB(2,I),I=1,NKEY)	00011600
READ(8,35) (KEYTAB(3,I),I=1,NKEY)	00011700
35 FORMAT(16I5)	00011800
DO 50 I=1,2	00011900
READ(8,40) (MINTAN(I,J),J=1,NLNKS)	00012000
READ(8,40) (MAXTAN(I,J),J=1,NLNKS)	00012100

40	FORMAT(20I4)	00012200
50	CONTINUE	00012300
	READ(8,60) IRSRV(1),IRSRV(2),ISRVY(1),ISRVY(2),IWKSP(1),IWKSP(2)	00012400
60	FORMAT(20A4)	00012500
	READ(8,65) PVIEW,ROLL,PITCH,YAW	00012600
65	FORMAT(I2,3F10.2)	00012700
	READ(8,90) ENDFLE	00012800
90	FORMAT(A4)	00012900
	IF(ENDFLE .EQ. END) GO TO 151	00013000
	WRITE(6,110) N	00013100
110	FORMAT(1X,33HINCORRECT AMOUNT OF DATA FOR PLOT,I2,	00013200
	-17H --PROGRAM ENDING)	00013300
	STOP	00013400
C		00013500
C***	PLOTTING ROUTINE	00013600
C		00013700
	151 CONTINUE	00013800
C		00013900
C	SPECIFY COLOR FOR THE BANNER	00014000
	CALL NEWPEN(ICOLOR(1))	00014100
C		00014200
C	PLOT THE BANNER	00014300
C		00014400
C		00014500
	REGRESSION MEMBER	00014600
	CALL SYMBOL(1.,1.25,.35,MSG1(1),90.,4)	00014700
	CALL SYMBOL(999.,999.,.35,MSG1(2),90.,4)	00014800
	CALL SYMBOL(999.,999.,.35,MSG1(3),90.,4)	00014900
	CALL SYMBOL(999.,999.,.35,IRSRV(1),90.,4)	00015000
	CALL SYMBOL(999.,999.,.35,IRSRV(2),90.,4)	00015100
C		00015200
C		00015300
	SURVEY MEMBER	00015400
	CALL SYMBOL(1.5,1.25,.35,MSG2(1),90.,4)	00015500
	CALL SYMBOL(999.,999.,.35,MSG2(2),90.,4)	00015600
	CALL SYMBOL(999.,999.,.35,MSG2(3),90.,4)	00015700
	CALL SYMBOL(999.,999.,.35,ISRVY(1),90.,4)	00015800
	CALL SYMBOL(999.,999.,.35,ISRVY(2),90.,4)	00015900
C		00016000
C		00016100
	CREW STATION MEMBER	00016200
	CALL SYMBOL(2.,1.25,.35,MSG3(1),90.,4)	00016300
	CALL SYMBOL(999.,999.,.35,MSG3(2),90.,4)	00016400
	CALL SYMBOL(999.,999.,.35,MSG3(3),90.,4)	00016500
	CALL SYMBOL(999.,999.,.35,IWKSP(1),90.,4)	00016600
	CALL SYMBOL(999.,999.,.35,IWKSP(2),90.,4)	00016700
C		00016800
C		00016900
	VIEW PLANE:	00017000
	CALL SYMBOL(2.5,1.25,.35,MSG4(1),90.,4)	00017100
	CALL SYMBOL(999.,999.,.35,MSG4(2),90.,4)	00017200
	CALL SYMBOL(999.,999.,.35,MSG4(3),90.,4)	00017300
C		00017400
C		00017500
	VIEW XY, XZ, YZ, OR OFF AXIS	00017600
	CALL SYMBOL(999.,999.,.35,IVIEW(PVIEW),90.,4)	00017700
	IF(PVIEW.EQ.4)CALL SYMBOL(999.,999.,.35,IVIEW(5),90.,4)	00017800
C		00017900

C	ROLL, PITCH, AND YAW	00017500
	CALL SYMBOL(3.0,1.25,.35,MSG5(1),90.,3)	00017600
	DO 155 I=2,6	00017700
155	CALL SYMBOL(999.,999.,.35,MSG5(I),90.,4)	00017800
C		00017900
C	ROLL ANGLE IN DEGREES	00018000
	YINC=0.	00018100
	IF(ABS(ROLL).GE.10.) YINC=.175	00018200
	IF(ABS(ROLL).GE.100.)YINC=.35	00018300
	IF(ROLL.LT.0.)YINC=YINC+.175	00018400
	CALL NUMBER(3.5,2.12-YINC,.35,ROLL,90.,1)	00018500
C		00018600
C	PITCH ANGLE IN DEGREES	00018700
	YINC=0.	00018800
	IF(ABS(PITCH).GE.10.) YINC=.175	00018900
	IF(ABS(PITCH).GE.100.)YINC=.35	00019000
	IF(PITCH.LT.0.)YINC=YINC+.175	00019100
	CALL NUMBER(3.5,4.75-YINC,.35,PITCH,90.,1)	00019200
C		00019300
C	YAW ANGLE IN DEGREES	00019400
	YINC=0.	00019500
	IF(ABS(YAW).GE.10.) YINC=.175	00019600
	IF(ABS(YAW).GE.100.)YINC=.35	00019700
	IF(YAW.LT.0.)YINC=YINC-.175	00019800
	CALL NUMBER(3.5,7.55-YINC,.35,YAW,90.,1)	00019900
C		00020000
C	PERSPECTIVE OR NON-PERSPECTIVE	00020100
	IF(IPERSP.EQ.1)CALL SYMBOL(4.,2.65,.35,15HNON-PERSPECTIVE,90.,15)	00020200
	IF(IPERSP.EQ.2)CALL SYMBOL(4.,3.35,.35,11HPERSPECTIVE,90.,11)	00020300
C		00020400
C	SCALE	00020500
	IF(FACTR.NE.99.) SCL=FACTR	00020600
	CALL SYMBOL(4.5,3.35,.35,6HSCALE=,90.,6)	00020700
	CALL NUMBER(999.,999.,.35,SCL,90.,2)	00020800
C		00020900
C	PLOT NUMBER	00021000
	PLT=N	00021100
	CALL SYMBOL(5.0,3.7,.35,5HPLOT=,90.,5)	00021200
	CALL NUMBER(999.,999.,.35,PLT,90.,-1)	00021300
C		00021400
C		00021500
C	RESET ORIGIN	00021600
	CALL PLOT(7.,0.,-3)	00021700
C		00021800
C		00021900
C	GO TO MAN-MODEL AND CREW STATION PLOT ROUTINE	00022000
	CALL CBMCP2(OX(1),OY(1))	00022100
C		00022200
	CALL FACTOR(1.0)	00022300
	CALL PLOT(12.,0.,-3)	00022400
	GO TO 5	00022500
C		00022600
C	PLOTE CLOSES OUT THE PLOT	00022700
130	CALL PLOTE(AA)	00022800
C		00022900
	STOP	00023000
	END	00023100

C		00123233
C	CBMCP2 - CALCOMP PLOT OF COMBINAN SECOND SUBROUTINE--ADJUSTED	00123350
C	FOR PLOTTING OFFLINE.	00023400
C		00023500
C	CALLED BY -	00123600
C	CBMOFF - CALCOMP (R) PLOT OF COMBINAN MAIN S/R	00123733
C		00023800
C	CALLS -	00023900
C	PLOT - CALCOMP ROUTINE (DRAW LINE OR POSITION THE PEN)	00024000
C	SYMBOL - CALCOMP ROUTINE (DRAW A SYMBOL, CHARACTER, OR	00024100
C	CHARACTER STRING)	00024233
C	NEWPEN - CALCOMP ROUTINE (CHANGE THE PEN COLOR)	00024300
C		00024400
C	INPUT FROM -	00024500
C	(NONE)	00024600
C		00024700
C	OUTPUT TO -	00024800
C	UNIT 7 - PLOTTER DATA	00024900
C		00025000
C	PARAMETERS -	00025100
C	X - ARRAY OF X VALUES TO BE PLOTTED	00025200
C	Y - ARRAY OF Y VALUES TO BE PLOTTED	00025300
C		00025400
C		00025500
C	SUBROUTINE CBMCP2(X,Y)	00025600
C	REAL X(1),Y(1)	00025733
C	COMMON/CBMXYZ/ KEYTAB(3,250),NLNKS,MINTAN(2,40),	00025800
C	1 MAXTAN(2,40),NKEY,NXYZ,ICOLOR(4),FLESH,FACTR,SCLE	00025900
C	INTEGER HIER(20),FLESH	00026000
C		00026100
C	PLOT MAN=MODEL AND CREW STATION	00026200
C		00026300
C	CALCULATE PLOTTING FACTOR	00026400
C	SCALE=FACTR/SCLE	00026500
C	IF(FACTR.EQ.99.) SCALE=1.	00026600
C	CALL FACTOR(SCALE)	00026700
C		00026800
C	PLOT THE LINK SYSTEM	00026900
C		00027000
C	J=IABS(KEYTAB(2,1))	00027100
C	HIER(J)=1	00027200
C	CALL PLOT(X(1),Y(1),3)	00027300
C	DO 50 I=2,NLNKS	00027400
C		00027500
C	SPECIFY COLOR FOR LINK SYSTEM	00027600
C	CALL NEWPEN(ICOLOR(2))	00027700
C		00027800
C	J=IABS(KEYTAB(2,I))	00027900
C	K=KEYTAB(1,I)	00028000
C	HIER(J)=I	00028100
C	LOCATE COORDINATE OF PREVIOUS POINT IN THE CHAIN	00028200
C	L=HIER(J-1)	00028300
C	CALL PLOT(X(L),Y(L),3)	00028400
C	10 M=2	00028500

C	CHECK IF OMIT OR INCLUDE STATUS	00028600
	IF (KEYTAB(2,I).LT.0.AND.KEYTAB(3,I).LT.0) M=3	00028700
	CALL PLOT(X(I),Y(I),M)	00028800
	J=IABS(KEYTAB(3,I))	00028900
	IF (J.EQ.1) GO TO 50	00029000
C		00029100
C	PLOT ENFLESHED MAN=MODEL	00029200
	IF(FLESH.EQ.1) GO TO 50	00029300
	30 KP=KEYTAB(1,I)+NLNKS-1	00029400
C		00029500
C	SPECIFY COLOR FOR ENFLESHMANT	00029600
C		00029700
	CALL NEWPEN(ICOLOR(3))	00029800
	L1=KP+KEYTAB(3,2)-2	00029900
	35 DO 45 L2=KP,L1	00030000
	CALL SYMBOL(X(L2)-.04,Y(L2),.175,1H.,0.0,1,-.175,0)	00030100
	45 CONTINUE	00030200
	IF (MINTAN(1,I).EQ.0) GO TO 50	00030300
	L1=MINTAN(1,I)+NLNKS	00030400
	L2=MINTAN(2,I)+NLNKS	00030500
	CALL PLOT(X(L1),Y(L1),3)	00030600
	CALL PLOT(X(L2),Y(L2),2)	00030700
	L1=MAXTAN(1,I)+NLNKS	00030800
	L2=MAXTAN(2,I)+NLNKS	00030900
	CALL PLOT(X(L1),Y(L1),3)	00031000
	CALL PLOT(X(L2),Y(L2),2)	00031100
	50 CONTINUE	00031200
C		00031300
C	PLOT CREW STATION PANELS	00031400
C		00031500
	IF (NLNKS.EQ.NKEY) RETURN	00031600
	II=NLNKS+1	00031700
C		00031800
C	SPECIFY COLOR FOR CREW STATION	00031900
C		00032000
	CALL NEWPEN(ICOLOR(4))	00032100
	DO 80 I=II,NKEY	00032200
	K=KEYTAB(1,I)+NXYZ+NLNKS	00032300
	CALL PLOT(X(K),Y(K),3)	00032400
	M=2	00032500
	IF (KEYTAB(2,I).LT.0.AND.KEYTAB(3,I).LT.0) M=3	00032600
	J=IABS(KEYTAB(3,I))	00032700
	L=K+1	00032800
	K=K+J-1	00032900
	DO 60 J=L,K	00033000
	60 CALL PLOT(X(J),Y(J),M)	00033100
	80 CONTINUE	00033200
	RETURN	00033300
	END	00033400

APPENDIX C-6  
COMBIMAN SOURCE - CBMCDM LISTING

```

C* * * * * 00000100
C 00000200
C CBMCDM - CREW STATION DATABASE MAINTENANCE MAIN ROUTINE 00000300
C 00000400
C CALLS - 00000500
C CBMCDP - HEADING AND PAGE CONTROL 00000600
C CBMCDT - DATE AND TIME FROM SYSTEM 00000700
C CBMCDT4 - COMPUTES DETERMINANT OF A 4X4 MATRIX 00000800
C CBMCDR - TRANSLATES COORD FROM AC LC SKP SYSTEM 00000900
C 00001000
C INPUT FROM - 00001100
C UNIT 1 - CREW STATION DATA BASE 00001200
C UNIT 5 - COMMAND & DATA STATEMENTS 00001300
C 00001400
C OUTPUT TO - 00001500
C UNIT 1 - CREW STATION DATA BASE 00001600
C UNIT 6 - PRINTER 00001700
C UNIT 7 - CARD PUNCH 00001800
C 00001900
C NOTE SIGNIFICANCE OF TYPE CODES AS FOLLOWS: 00002000
C 0,1 - STANDARD WORKPLACE PANEL 00002100
C 2 - SEAT 00002200
C 3 - RUDDER/BRAKE PEDAL 00002300
C 4 - CONTROL STICK 00002400
C 5 - THROTTLE 00002500
C 6 - COLLECTIVE 00002600
C 7 - WHEEL-TYPE 00002700
C 00002800
C THE MAXIMUM NUMBER OF TYPE CODES FOR SPECIAL PROCESSING 00002900
C IS 15. 00003000
C 00003100
C* * * * * 00003200
C 00003300
C DEFINE FILE 1(2000,92,U,IAV1) 00003400
C 00003500
C COMMON /CBMCDM/ IMT, IDY, IYR, IHR, IMN, ISC, IPG, ILN 00003600
C 00003700
C INTEGER MAXREC/2000/, IWKSP/4H*WKSP/, BLANK/4F /, PNV, 00003800
1 ICBL/4H*IBL/, IADD/4H*ADD/, IEND/4H*END/, 00003900
2 IINT/4H*INT/, IPRT/4H*PRT/, IDMP/4H*DMP/, 00004000
3 IPCH/4H*PCH/, ICHK/4H*CHK/, ICMP/4H*CMP/, 00004100
4 IDUMP(23), IPX(6), IPY(6), IPZ(6), NAME(2), INAME(2), 00004200
5 ITYP(6)/IHF, IHA, IFL, IFR, IFC, IFD/, 00004300
6 ITYPE(6)/1,-1,2,-2,3,-3/, INTD(4)/2,21,22,21/, 00004400
7 PNL(300), PNAME(2,300), PTYPE(300), PNVRT(300), 00004500
8 CNAME(2,300), CTYPE(300), CPNL(300), CPT(300), NPPLT(15) 00004600
C 00004700
C REAL BLSXYZ(3), CXYZ(5,300), CRIGIN(3), PXYZ(3,6,300), 00004800
1 PX(6), PY(6), PZ(6) 00004900
C 00005000
C CALL CBMCDT(IMT, IDY, IYR, I, IHR, IMN, ISC) 00005100
C IPG=0 00005200
C PAGE COUNTER 00005300
C----- 00005400
C READ COMMAND CARD AND PROCESS IT 00005500
C TERMINATE PROGRAM IF COMMAND (IDPER) IS INVALID 00005600
C----- 00005700
10 READ (5,1000,END=720) IDPR,NAME,NPNS,NOTLS,BLSXYZ,IX,IY,IZ 00005800
IF (ICPR.EQ.ICHK) GO TO 15 00005900
IF (ICPR.EQ.IADD) GO TO 20 00006000
IF (ICPR.EQ.IDEL) GO TO 20 00006100

```



```

      IF (IY.EC.ITYP(I)) GO TO 60
C          CHECK Y AXIS DIRECTION
50 CONTINUE
  CALL CBMCCP(1)
  WRITE (6,2C09) IY,NAME
C          WRONG Y AXIS DIRECTION
      GC TO 10
C          READ NEXT COMMAND CARD
60 CONTINUE
  IY1 = IABS(ITYPE(I))
  IY2 = ISIGN(1,ITYPE(I))
  DC 70 I=1,6
  IF (IZ.EC.ITYP(I)) GO TO 72
C          CHECK Z AXIS DIRECTION
70 CONTINUE
  CALL CBMCCP(1)
  WRITE (6,2C10) IZ,NAME
C          WRONG Z AXIS DIRECTION
      GC TO 10
C          READ NEXT COMMAND CARD
72 CONTINUE
  IZ1 = IABS(ITYPE(I))
  IZ2 = ISIGN(1,ITYPE(I))
  IF (IX1.NE.IY1.AND.IX1.NE.IZ1.AND.IY1.NE.IZ1) GO TO 74
C          CHECK FOR UNIQUE X, Y, & Z DIRECTIONS
  CALL CBMCCP(1)
  WRITE (6,2C11) NAME
  GC TO 10
C          X, Y, & Z DIRECTIONS NOT UNIQUE
74 CONTINUE
  READ (1,1,ERR=810) JWKSP,I11,I12,I01,I02,MAX
C          READ FIRST RECORD ON DATA BASE
  IF (JWKSP.NE.IWKSP) GO TO 810
C          CHECK CREW STATION DATA BASE IDENTIFIER
  IF (I02+NPNS+NCNLS-1.LE.MAX) GO TO 76
C          CHECK IF THERE IS SPACE TO ADD DATA
  CALL CBMCCP(1)
  WRITE (6,2C01) NAME
C          PRINT - NO SPACE TO ADD DATA
  JCFK = JCFK+1
76 CONTINUE
  IECE = 0
C          INITIALIZE DIRECTORY RECORD COUNTER
C-----
C          READ RECORDS IN THE DIRECTORY AND CHECK MEMBERNAME
C          ENTRIES. IF THE NAME READ FROM INPUT EXISTS ON THE
C          DIRECTORY THE NEW MEMBER IS NOT ADDED. IF THERE IS
C          SPACE ON THE DIRECTORY AGAIN THE DATA IS NOT ADDED.
C-----
  DC 80 I=I11,I12
  READ (1,1,ERR=850) INAME,I03,I04,IPNS,ICNLS,CRIGIN
  IF (NAME(I).EQ.INAME(1).AND.NAME(2).EQ.INAME(2))
1    GC TO 800
C          MEMBER NAME EXISTS - CANNOT ADD DATA
  IF (INAME(1).EQ.BLANK.AND.INAME(2).EQ.BLANK) IBDE=1
80 CONTINUE
  IF (IECL.NE.0) GO TO 82
  CALL CBMCCP(1)
  WRITE (6,2C12) NAME
C          PRINT - DIRECTORY IS FULL
  JCFK = JCFK+1

```

```

00012300
00012400
00012500
00012600
00012700
00012800
00012900
00013000
00013100
00013200
00013300
00013400
00013500
00013600
00013700
00013800
00013900
00014000
00014100
00014200
00014300
00014400
00014500
00014600
00014700
00014800
00014900
00015000
00015100
00015200
00015300
00015400
00015500
00015600
00015700
00015800
00015900
00016000
00016100
00016200
00016300
00016400
00016500
00016600
00016700
00016800
00016900
00017000
00017100
00017200
00017300
00017400
00017500
00017600
00017700
00017800
00017900
00018000
00018100
00018200
00018300

```

```

      82 CONTINUE                                00018400
         IC3 = ID2+1                            00018500
         ID4 = ID2+NPPLS+NCTLS                 00018600
         CALL CBMCCP(3)                        00018700
         WRITE (6,2019) NAME,NPPLS,NCTLS,BCSXYZ,IX,IY,IZ 00018800
C-----
C          READ COORDINATE DATA FOR ALL PANELS AND PROCESS 00018900
C-----
      DC 11C I=1,NPPLS                          00019200
      READ (5,IC02,END=720) PNC(I),(PNAME(J,1),J=1,2),PTYPE(I),
1      PNV,(PX(J),PY(J),PZ(J),J=1,PNV)        00019300
      K = I-1                                    00019500
      DC 83 J=1,K                               00019600
      IF (I.NE.1.AND.PNC(J).EQ.PNC(I)) GC TO 84 00019700
C          CHECK FOR UNIQUE PANEL NUMBER          00019800
      83 CONTINUE                              00019900
      GC TO 86                                  00020000
      84 CONTINUE                              00020100
      CALL CBMCCP(1)                            00020200
      WRITE (6,2025) (PNAME(L,1),L=1,2),(PNAME(L,J),L=1,2) 00020300
      JCHK = JCHK+1                             00020400
      86 CONTINUE                              00020500
      IF (I.EQ.1) GC TO 85                     00020600
      DC 87 J=1,K                               00020700
      IF (PNAME(1,J).EQ.PNAME(1,1).AND.PNAME(2,J).EQ.PNAME(2,1))
1      GC TO 88                                00020800
C          CHECK FOR UNIQUE PANEL NAME          00020900
      87 CONTINUE                              00021000
      GC TO 89                                  00021100
      88 CONTINUE                              00021200
      CALL CBMCCP(1)                            00021300
      WRITE (6,2024) (PNAME(L,1),L=1,2),PNC(J),PNC(I) 00021400
      JCHK=JCHK+1                             00021500
      89 CONTINUE                              00021600
      IF (PTYPE(I).LT.0.OR.PTYPE(I).GT.15) GC TO 92 00021700
C          CHECK FOR VALID PANEL TYPE          00021800
      IF (PTYPE(I).EQ.0) PTYPE(I)=1           00021900
C          COUNTER FOR PANEL TYPES            00022000
      NPPLT(PTYPE(I)) = NPPLT(PTYPE(I))+1    00022100
      GC TO 93                                  00022200
      92 CONTINUE                              00022300
      CALL CBMCCP(1)                            00022400
      WRITE (6,2033) PTYPE(I),(PNAME(J,1),J=1,2) 00022500
      93 CONTINUE                              00022600
      IF (PNV.GE.0.AND.PNV.LE.6) GC TO 94      00022700
C          CHECK FOR NUMBER OF VERTICES        00022800
      WRITE (6,2020) PNV,(PNAME(J,1),J=1,2)  00022900
      IF (PNV.LT.3) PNV=3                      00023000
      IF (PNV.GT.6) PNV=6                      00023100
C          THE ABOVE TWO STATEMENTS MAY APPEAR 00023200
C          AS FUDDING. IN FACT, THEY ARE MEANT 00023300
C          TO BE DEBUGGING AIDS.              00023400
      JCHK = JCHK+1                             00023500
      94 CONTINUE                              00023600
      IF (PNV.LT.4) GC TO 98                   00023700
C-----
C          CHECK IF THE VERTICES ARE COLLINEAR 00023800
C-----
      I1 = PNV-3                                00023900
      I2 = PNV-2                                00024000
      I3 = PNV-1                                00024100

```

	DC 95 J1=1,I1	00024500
	DO 95 J2=2,I2	00024600
	DC 95 J3=1,I3	00024700
	DC 95 J4=4,PNV	00024800
	IF (J4.LE.J3.OR.J3.LE.J2.OR.J2.LE.J1) GC TO 95	00024900
	C = CBMDT4(PX(J1),PY(J1),PZ(J1),1.0,PX(J2),PY(J2),PZ(J2),	00025000
1	1.0,PX(J3),PY(J3),PZ(J3),1.0,PX(J4),PY(J4),PZ(J4),1.0)	00025100
	IF (ABS(C).LE.0.10) GC TO 95	00025200
	CALL CBMCLDP(1)	00025300
	WRITE (6,2027) (PNAME(J,1),J=1,2),J1,J2,J3,J4,D	00025400
95	CONTINUE	00025500
98	CONTINUE	00025600
	PNVRT(I) = PNV	00025700
C	-----	00025800
C	TRANSLATE COORDINATES TO SRP SYSTEM AND	00025900
C	WRITE TO DATA BASE IF NO ERRORS	00026000
C	-----	00026100
	DC 100 J=1,PNV	00026200
	CALL CBMTRN(PX(J),PY(J),PZ(J),PXYZ(1,J,1),BCSXYZ,	00026300
1	1X1,IY1,IZ1,1X2,IY2,IZ2)	00026400
100	CONTINUE	00026500
	CALL CBMCLDP(PNV+1)	00026600
	WRITE (6,1003) PNC(I), (PNAME(J,1),J=1,2),PTYPE(I),PNV,	00026700
1	(PX(J),PY(J),PZ(J), (PXYZ(K,J,1),K=1,3),J=1,PNV)	00026800
	IF (JCHK.EQ.0)	00026900
1	WRITE (1,I02+1) PNO(I), (PNAME(J,1),J=1,2),FTYPE(I),	00027000
2	PNV, ((PXYZ(K,J,1),K=1,3),J=1,PNV)	00027100
110	CONTINUE	00027200
C	END OF LOOP FOR THE PANEL DATA	00027300
C	-----	00027400
C	READ AND PROCESS COORDINATE DATA FOR CONTROLS	00027500
C	-----	00027600
	CALL CBMCLDP(1)	00027700
	WRITE (6,1012)	00027800
	DC 150 I=1,NCPLS	00027900
	READ (5,1004,END=720)	00028000
1	(CNAME(J,1),J=1,2),LTYPE(I),CPNL(I),CPT(I),C1,C2,C3	00028100
	IF (CPNL(I).NE.0) GC TO 115	00028200
C	NE.0 ==> DEFINED RELATIVE TO A PANEL	00028300
C	IF (CPT(I).EQ.C) GC TO 135	00028400
C	EQ.0 ==> DEFINED IN ABSOLUTE COORD	00028500
C	WRITE (6,2013) (CNAME(J,1),J=1,2)	00028600
C	ERRCK IN DEFINITION OF COORD SYSTEM	00028700
	JCHK = JCHK+1	00028800
	GC TO 117	00028900
115	CONTINUE	00029000
	DL 116 IPNL=1,IPNLS	00029100
	IF (PNO(IPNL).EQ.CPNL(I)) GC TO 120	00029200
C	CHECK IF DEFINED PANEL EXISTS	00029300
116	CONTINUE	00029400
	CALL CBMCLDP(1)	00029500
	WRITE (6,2002) CPNL(I), (CNAME(J,1),J=1,2)	00029600
C	DEFINED PANEL DOES NOT EXIST	00029700
	JCHK = JCHK+1	00029800
117	CONTINUE	00029900
	CPNL(I) = 0	00030000
	CPT(I) = 0	00030100
	GC TO 135	00030200
120	CONTINUE	00030300
	IF (CPT(I).GE.1.AND.CPT(I).LE.PNVRT(IPNL)) GC TO 130	00030400
C	CHECK IF DEFINED VERTEX EXISTS	00030500

	CALL CBMCDP(I)	00030600
	WRITE (6,2003) CPT(I),(CNAME(J,I),J=1,2)	00030700
C	DEFINED VERTEX DOES NOT EXIST	00030800
	CPT(I) = 1	00030900
	JCHK = JCHK+1	00031000
130	CONTINUE	00031100
	IF (C3.EQ.0.0) GO TO 131	00031200
C	FOR RELATIVE DEFN. Z COORD IS 0.0	00031300
	CALL CBMCDP(I)	00031400
	WRITE (6,2004) (CNAME(J,I),J=1,2)	00031500
	CPNL(I) = 0	00031600
	CPT(I) = 0	00031700
	JCHK = JCHK+1	00031800
	GO TO 135	00031900
131	CONTINUE	00032000
	CXYZ(4,I) = C1	00032100
	CXYZ(5,I) = C2	00032200
C	-----	00032300
C	COMPUTE ABSOLUTE COORDINATES FROM RELATIVE COORDINATE	00032400
C	-----	00032500
	IC = CPT(I)	00032600
	IE = IC-1	00032700
	IA = IC+1	00032800
	IF (IA.EQ.PNVRT(IPNL)+1) IA=1	00032900
	IF (IE.EQ.0) IE=PNVRT(IPNL)	00033000
	CX = SQRT((PXYZ(1,IE,IPNL)-PXYZ(1,IC,IPNL))**2+	00033100
1	(PXYZ(2,IE,IPNL)-PXYZ(2,IC,IPNL))**2+	00033200
2	(PXYZ(3,IE,IPNL)-PXYZ(3,IC,IPNL))**2)	00033300
	DY = SQRT((PXYZ(1,IA,IPNL)-PXYZ(1,IC,IPNL))**2+	00033400
1	(PXYZ(2,IA,IPNL)-PXYZ(2,IC,IPNL))**2+	00033500
2	(PXYZ(3,IA,IPNL)-PXYZ(3,IC,IPNL))**2)	00033600
	T1 = ABS(C1)/CX	00033700
	T2 = ABS(C2)/DY	00033800
	T3 = 1.0-T1-T2	00033900
	DC 134 J=1,3	00034000
	CXYZ(J,I) = T1*PXYZ(J,IE,IPNL) + T2*PXYZ(J,IA,IPNL) +	00034100
1	T3*PXYZ(J,IC,IPNL)	00034200
134	CONTINUE	00034300
	GO TO 142	00034400
135	CONTINUE	00034500
	IFNL = 0	00034600
	CXYZ(4,I) = 0.0	00034700
	CXYZ(5,I) = 0.0	00034800
C	-----	00034900
C	TRANSLATE COORDINATES TO SRP SYSTEM	00035000
C	-----	00035100
	CALL CBMTRN(C1,C2,C3,CXYZ(1,I),BCSXYZ(I),IX1,IY1,IZ1,	00035200
1	IX2,IY2,IZ2)	00035300
142	CONTINUE	00035400
	IF (I.EQ.1) GO TO 145	00035500
	K = I-1	00035600
	DC 141 J=1,K	00035700
	IF (CNAME(I,J).EQ.CNAME(1,I).AND.CNAME(2,J).EQ.CNAME(2,I))	00035800
1	GO TO 146	00035900
C	CHECK IF CONTROL NAME IS UNIQUE	00036000
141	CONTINUE	00036100
	GO TO 145	00036200
146	CONTINUE	00036300
	CALL CBMCDP(I)	00036400
	WRITE (6,2026) (CNAME(K,I),K=1,2)	00036500
C	DUPLICATE CONTROL NAME	00036600



	DC 220 I=I11,I12	00042800
	READ (1'1,ERR=850) INAME, I03, I04, IPNLS, ICTLS, CRIGIN, IX, IY, IZ	00042900
C	READ DIRECTORY BLOCKS	00043000
	IF (NAME(1).EQ.INAME(1).AND.NAME(2).EQ.INAME(2)) GO TO 230	00043100
C	CHECK FOR MEMBER NAME	00043200
	220 CONTINUE	00043300
	WRITE (6,2006) NAME	00043400
C	MEMBER NAME DOES NOT EXIST	00043500
	GO TO 10	00043600
C	READ NEXT COMMAND CARD	00043700
	230 CONTINUE	00043800
	WRITE (6,1007) NAME	00043900
C	MEMBER NAME EXISTS	00044000
	ID5 = 0	00044100
	WRITE (1'1) BLANK, BLANK, (IC5, J=1, 10)	00044200
C	DELETE MEMBER NAME FROM DIRECTORY	00044300
	GO TO 10	00044400
C	READ NEXT COMMAND CARD	00044500
C		00044600
C	-----	00044700
C	INITIALIZE DATA BASE	00044800
C	-----	00044900
	250 CONTINUE	00045000
	CALL CBMCCP(0)	00045100
	WRITE (6,1001) IDPR	00045200
	WRITE (6,1008)	00045300
	WRITE (1'1) IWKSP, INTC, MAXREL	00045400
C	WRITE FIRST RECORD ON DATA BASE	00045500
	I11 = INTC(1)	00045600
	I12 = INTC(2)	00045700
	J = 0	00045800
	DC 260 I=I11,I12	00045900
	260 WRITE (1'1) BLANK, BLANK, (J, K=1, 10)	00046000
C	ENTER BLANKS FOR MEMBER NAMES	00046100
	GO TO 10	00046200
C	READ NEXT COMMAND CARD	00046300
C		00046400
C	-----	00046500
C	PRINT CREW STATION DATA BASE - IF INPUT MEMBER NAME	00046600
C	DOES NOT EXIST, THE DIRECTORY IS PRINTED	00046700
C	-----	00046800
	300 CONTINUE	00046900
	CALL CBMCCP(0)	00047000
	WRITE (6,1001) IDPR, NAME	00047100
	READ (1'1,ERR=810) JWKSP, I11, I12, ID1, ID2, MAX	00047200
C	READ HEADER RECORD OF DATA BASE	00047300
	IF (JWKSP.NE.IWKSP) GO TO 810	00047400
C	CHECK FOR VALID DATA BASE	00047500
	IF (NAME(1).EQ.BLANK.AND.NAME(2).EQ.BLANK) GO TO 360	00047600
C	CHECK IF INPUT NAME IS BLANK	00047700
	DC 310 I=I11,I12	00047800
	READ (1'1,ERR=850) INAME, I03, I04, NPNSL, NCTLS, CRIGIN, IX, IY, IZ	00047900
C	READ DIRECTORY BLOCKS	00048000
	IF (NAME(1).EQ.INAME(1).AND.NAME(2).EQ.INAME(2)) GO TO 320	00048100
C	CHECK IF MEMBER NAME EXISTS	00048200
	310 CONTINUE	00048300
	GO TO 350	00048400
C	MEMBER NAME DOES NOT TALLY	00048500
	320 CONTINUE	00048600
	IC5 = I03+NPNSL-1	00048700
	CALL CBMCCP(1)	00048800

C	WRITE (6,1011) I, INAME, ID3, ID4, NPMLS, NCTLS, ORIGIN, IX, IY, IZ	00048900
	PRINT DIRECTORY INFO FOR MEMBER	00049000
	DC 330 I=ID3, ID5	00049100
	K = I-ID3+1	00049200
	READ (1'1, ERR=880) PND(K), (PNAME(J, K), J=1, 2), FTYPE(K), PNV,	00049300
1	((PXYZ(L, J, K), L=1, 3), J=1, PNV)	00049400
	PNVRT(K) = PNV	00049500
	CALL CBMCDP(PNV+1)	00049600
	WRITE (6,1009) PNC(K), (PNAME(J, K), J=1, 2), PTYPE(K), PNV,	00049700
1	((PXYZ(L, J, K), L=1, 3), J=1, PNV)	00049800
C	WRITE PANEL DATA	00049900
330	CONTINUE	00050000
	WRITE (6,1010)	00050100
	ID5 = ID5+1	00050200
	DC 340 I=ID5, ID4	00050300
	READ (1'1, ERR=890) INAME, JTYP, IPNL, IPT, C1, C2, C3, C4, C5	00050400
	IF (IPNL.EC.0) GO TO 334	00050500
	DC 333 J = 1, NPMLS	00050600
	IF (IPNL.EC.PND(J)) GO TO 335	00050700
333	CONTINUE	00050800
334	CONTINUE	00050900
	NAME(1) = BLANK	00051000
	NAME(2) = BLANK	00051100
	GO TO 337	00051200
335	CONTINUE	00051300
	NAME(1) = PNAME(1, J)	00051400
	NAME(2) = PNAME(2, J)	00051500
337	CONTINUE	00051600
	CALL CBMCDP(1)	00051700
	WRITE (6,1006) INAME, JTYP, NAME, IPT, C1, C2, C3, C4, C5	00051800
C	WRITE DATA FOR CONTROLS	00051900
340	CONTINUE	00052000
	GO TO 10	00052100
C	READ NEXT COMMAND CARD	00052200
350	CONTINUE	00052300
	CALL CBMCDP(1)	00052400
	WRITE (6,2006) NAME	00052500
C	PRINT - MEMBER NOT FOUND	00052600
360	CONTINUE	00052700
	DC 370 I=111, 112	00052800
	READ (1'1, ERR=850) INAME, ID3, ID4, NPMLS, NCTLS, ORIGIN, IX, IY, IZ	00052900
	IF (INAME(1).EQ.BLANK.AND.INAME(2).EQ.BLANK) GO TO 370	00053000
	CALL CBMCDP(1)	00053100
	WRITE (6,1011) I, INAME, ID3, ID4, NPMLS, NCTLS, ORIGIN, IX, IY, IZ	00053200
C	PRINT DIRECTORY BLOCKS	00053300
370	CONTINUE	00053400
	GO TO 10	00053500
C	READ NEXT COMMAND CARD	00053600
C		00053700
C	-----	00053800
C	COMP CREW STATION DATA SET - IF INPUT MEMBER NAME	00053900
C	IS BLANK, JUMP THE ENTIRE DATA BASE	00054000
C	-----	00054100
400	CONTINUE	00054200
	CALL CBMCDP(0)	00054300
	WRITE (6,1001) IUPR, NAME	00054400
	IF (NAME(1).NE.BLANK.OR.NAME(2).NE.BLANK) GO TO 420	00054500
C	CHECK IF INPUT NAME IS BLANK	00054600
	DC 410 I=1, MAXPEC	00054700
	READ (1'1) IDJMP	00054800
	CALL CBMCDP(3)	00054900

	WRITE (6,1013) I, IDUMP, IDUMP	00055000
410	CONTINUE	00055100
C	DUMP DATA BASE IF INPLT IS ELANK	00055200
	GO TO 10	00055300
C	READ NEXT COMMAND CARD	00055400
420	CONTINUE	00055500
	READ (1'1,ERR=810) JWKSP, I11, I12, ID1, ID2, MAX	00055600
	IF (JWKSP.NE.IWKSP) GO TO E10	00055700
C	CHECK FOR VALID CREW STATION	00055800
	DC 430 I=I11, I12	00055900
	READ (1'1,ERR=850) INAME, ID3, ID4, NPMLS, NCTLS, CRIGIN, IX, IY, IZ	00056000
	IF (INAME(1).EQ.NAME(1).AND.INAME(2).EQ.NAME(2)) GO TO 440	00056100
C	CHECK DIRECTORY FOR MEMBER NAME	00056200
430	CONTINUE	00056300
	WRITE (6,2006) NAME	00056400
C	MEMBER NAME DOES NOT EXIST	00056500
	GO TO 10	00056600
C	READ NEXT COMMAND CARD	00056700
440	CONTINUE	00056800
	CALL CBMCCP(1)	00056900
	WRITE (6,1011) I, INAME, ID3, ID4, NPMLS, NCTLS, CRIGIN, IX, IY, IZ	00057000
C	PRINT DIRECTORY INFO OF MEMBER	00057100
	DC 450 I=ID3, ID4	00057200
	READ (1'1) IDUMP	00057300
	CALL CBMCCP(3)	00057400
	WRITE (6,1013) I, IDUMP, IDUMP	00057500
C	DUMP MEMBER DATA	00057600
450	CONTINUE	00057700
	GO TO 10	00057800
C	READ NEXT COMMAND CARD	00057900
C		00058000
C	-----	00058100
C	PUNCH CREW STATION DATA BASE MEMBER	00058200
C	-----	00058300
500	CONTINUE	00058400
	CALL CBMCCP(J)	00058500
	WRITE (6,1001) IOPR, NAME	00058600
	READ (1'1,ERR=810) JWKSP, I11, I12, ID1, ID2, MAX	00058700
	IF (JWKSP.NE.IWKSP) GO TO E10	00058800
C	CHECK FOR VALID DATA BASE	00058900
	IF (NAME(1).EQ.BLANK.AND.NAME(2).EQ.BLANK) GO TO 560	00059000
C	CHECK IF INPUT MEMBER NAME IS BLANK	00059100
	DC 510 I=I11, I12	00059200
	READ (1'1,ERR=850) INAME, ID3, ID4, NPMLS, NCTLS, CRIGIN, IX, IY, IZ	00059300
	IF (INAME(1).EQ.INAME(1).AND.INAME(2).EQ.INAME(2)) GO TO 520	00059400
C	CHECK IF NAMES TALLY	00059500
510	CONTINUE	00059600
	WRITE (6,2006) NAME	00059700
C	NAMES DO NOT TALLY	00059800
	GO TO 10	00059900
C	READ THE NEXT COMMAND CARD	00060000
520	CONTINUE	00060100
	I05 = ID3+NPMLS-1	00060200
	WRITE (7,1014) NAME, NPMLS, NCTLS	00060300
	DC 530 I=ID3, ID5	00060400
	READ (1'1,ERR=860) IND, INAME, JTYP, INV,	00060500
1	(PX(J), PY(J), PZ(J), J=1, INV)	00060600
C	READ PANEL DATA FROM DATA BASE	00060700
	DC 528 J=1, INV	00060800
	IPX(J) = IFIX(PX(J)*100.C)	00060900
	IPY(J) = IFIX(PY(J)*100.C)	00061000

	IPZ(J) = IFIX(PZ(J)*100.0)	00061100
C	CONVERT DATA TO INTEGER FORMAT	00061200
528	CONTINUE	00061300
	WRITE (7,1015) INO,INAME,JTYP,INV,	00061400
1	(IPX(J),IPY(J),IPZ(J),J=1,INV)	00061500
C	PUNCH PANEL DATA	00061600
530	CONTINUE	00061700
	ID5 = I03+NPNLS	00061800
	DC 540 I=IC5,IC4	00061900
	READ (1'I,ERR=880) INAME,JTYP,IPNL,IPT,C1,C2,C3,C4,C5	00062000
C	READ DATA FOR CONTRCLS	00062100
	IF (IPNL.EQ.0) GO TO 535	00062200
C	CHECK IF DATA IS ABSOLUTE	00062300
	IC4 = IFIX(IL4*100.0)	00062400
	IC5 = IFIX(IC5*100.0)	00062500
	WRITE (7,1016) INAME,JTYP,IPNL,IPT,IC4,IC5	00062600
	GO TO 540	00062700
535	CONTINUE	00062800
	IC1 = IFIX(C1*100.0)	00062900
	IC2 = IFIX(C2*100.0)	00063000
	IC3 = IFIX(C3*100.0)	00063100
	WRITE (7,1017) INAME,JTYP,IPNL,IPT,IC1,IC2,IC3	00063200
540	CONTINUE	00063300
	WRITE (6,2021) NAME	00063400
C	PRINT PUNCH MESSAGE	00063500
	GO TO 10	00063600
C	READ NEXT COMMAND CARD	00063700
500	CONTINUE	00063800
	WRITE (6,2005) IDPR	00063900
C	PRINT - AC NAME GIVEN	00064000
	GO TO 10	00064100
C	READ NEXT COMMAND CARD	00064200
C		00064300
C	-----	00064400
C	COMPRESS CREW STATION DATABASE FUNCTION	00064500
C	1. GOES THROUGH MEMBER LIST TO LOCATE LOWER MOST MEMBER	00064600
C	2. CHECKS IF THE MEMBER HAS LEFT A GAP	00064700
C	3. IF YES, REWRITE MEMBER CLOSING THE GAP	00064800
C	4. DELETE MEMBER FROM MEMBER LIST AND GO TO 1	00064900
C	-----	00065000
600	CONTINUE	00065100
	CALL CBMCCP(3)	00065200
	WRITE (6,1001) IDPR,NAME	00065300
	READ (1'I,ERR=810) JWKSP,I11,I12,IC1,IC2,MAX	00065400
	IF (JWKSP.NE.IWKSP) GO TO 610	00065500
C	CHECK FOR VALID CREW STATION	00065600
	IBTM = ID1	00065700
610	CONTINUE	00065800
	ITCP = ID2	00065900
	I1 = C	00066000
	DC 620 I=I11,I12	00066100
	READ (1'I,ERR=850) INAME,IC3,IC4,NPNLS,NO1LS,ORIGIN,IX,IY,IZ	00066200
	IF (IC3.EQ.ITCP.OR.IC3.LT.IBTM .OR.	00066300
1	(INAME(1).EQ.BLANK.AND.INAME(2).EQ.BLANK))	00066400
2	GO TO 620	00066500
	I1 = I	00066600
	ITCP = IC3	00066700
620	CONTINUE	00066800
	IF (I1.EQ.0) GO TO 660	00066900
	READ (1'I1,ERR=850) INAME,IC5,IC4,NPNLS,NO1LS,ORIGIN,IX,IY,IZ	00067000
	IF (ITCP.EQ.IBTM) GO TO 640	00067100

K = I03-1	00067200
L = IBTM-1	00067300
J = NPMLS+NCTLS	00067400
DC 63C I=1,J	00067500
READ (1'K+1,ERR=680) ICUMP	00067600
WRITE (1'L+1) IOUMP	00067700
630 CONTINUE	00067800
I03 = L+1	00067900
I04 = L+J	00068000
WRITE (1'II) INAME, I03, I04, NPMLS, NCTLS, CRIGIN, IX, IY, IZ	00068100
CALL CEMCOP(1)	00068200
WRITE (6,2022) INAME	00068300
IBTM = I04+1	00068400
GC TO 610	00068500
640 CONTINUE	00068600
CALL CEMCOP(1)	00068700
WRITE (6,2023) INAME	00068800
IBTM = I04+1	00068900
GC TO 610	00069000
660 CONTINUE	00069100
I02 = IBTM-1	00069200
WRITE (1'1) JWKSP, I11, I12, I01, I02, MAX	00069300
WRITE (6,2032)	00069400
GC TO 10	00069500
C	00069600
READ NEXT COMMAND CARD	00069700
C-----	00069800
C	00069900
END OF PROGRAM MESSAGES	00070000
C-----	00070100
700 CONTINUE	00070200
CALL CEMCOP(0)	00070300
WRITE (6,1001) ICPR	00070400
WRITE (6,2099)	00070500
STPL	00070600
C-----	00070700
C	00070800
END OF INPUT DATA	00070900
C-----	00071000
720 CONTINUE	00071100
WRITE (6,2015)	00071200
WRITE (6,2099)	00071300
STEP	00071400
C-----	00071500
C	00071600
DUPLICATE MEMBER NAME	00071700
C-----	00071800
800 CONTINUE	00071900
WRITE (6,2014) NAME	00072000
GC TO 10	00072100
C-----	00072200
C	00072300
INVALID CREW STATION DATA BASE	00072400
C-----	00072500
810 CONTINUE	00072600
WRITE (6,2031)	00072700
WRITE (6,2099)	00072800
STEP	00072900
850 CONTINUE	00073000
WRITE (6,2016) IAV1	00073100
C	00073200
WRONG INDEX RECCRD	00073300
STEP	00073400
880 CONTINUE	00073500
WRITE (6,2017) IAV1	00073600
C	00073700
WRONG DATA RECCRD	00073800
STEP	00073900

-----		00073300
C	FORMAT STATEMENTS	00073400
-----		00073500
1000	FORMAT(A4,1X,2A4,2I4,3F6.2,1X,A1,1X,A1,1X,A1)	00073600
1001	FORMAT(9F CBM1001 ,A4,1X,2A4,2I4,3F6.2,1X,A1,1X,A1,1X,A1)	00073700
1002	FORMAT(I3,2A4,I3,3X,I1,9F6.2,8X/12F6.2,EX)	00073800
1003	FORMAT(I15,3H.) ,2A4,7H, TYPE=,12,1H,,12,2CF VERTICES --INPUT CC,	00073900
X	40HCOORDINATES--- --ABSOLUTE COORDINATES--/(48X,1H(,3F7.2,00074000	
X	6H) TC (,3F7.2,1H))	00074100
1004	FORMAT(2A4,1C,13,11,3F6.2)	00074200
1005	FORMAT(11X,2A4,15,1X,2A4,14,4F (,3F7.2,6H) TC (,3F7.2,5H) & (,	00074300
X	2F7.2,1H))	00074400
1006	FORMAT(11X,2A4,15,1X,2A4,13,4H (,3F7.2,5H) (,2F7.2,1H))	00074500
1007	FORMAT(9H CBM1231 ,2A4,9H DELETED.)	00074600
1008	FORMAT(21F CBM1241 INITIALIZED.)	00074700
1009	FORMAT(I15,3H.) ,2A4,7H, TYPE=,12,1H,,12,21F VERTICES --ABSOLUTE ,00074800	
X	12HCOORDINATES--/(48X,1H(,3F7.2,1H))	00074900
1010	FORMAT(10X,51F CONTROL- TYPE IN-PANEL POINT --ABSOLUTE COORDINATE,00075000	
X	23FS- RELATIVE-COORDINATE/11X,8(1H-),6H ---- ,8(1H-),	00075100
X	7H ---- ,23(1H-),2),19(1H-))	00075200
1011	FORMAT(I15,3H.) ,2A4,10H, EXTENT=(,18,1H,,18,2F),,14,8H PANELS,,	00075300
X	1+,19H CONTROLS, ORIGIN=(,F7.2,1H,,F7.2,1H,,F7.2,7H), ORIE,00075400	
X	5HNT=(,A1,1H,,A1,1H,,A1,2F.)	00075500
1012	FORMAT(10X,51F CONTROL- TYPE IN-PANEL POINT --- (INPUT COORDINATES--00075600	
X	51F--- --ABSOLUTE COORDINATES- RELATIVE-COORDINATES/11X,00075700	
X	8(1H-),6H ---- ,8(1H-),7H ---- ,23(1H-),4X,23(1H-),2X,	00075800
X	19(1H-))	00075900
1013	FORMAT(11X,6HRECORD,15,3H+==,2A4,3H+==/11X,5H+==,12Z8,5H+==/11X,	00076000
X	3H+==,11Z3,3H+==)	00076100
1014	FORMAT(5H\$ACD ,2A4,2I4,24F O.C O.C C.C F L C)	00076200
1015	FORMAT(I3,2A4,3X,I3,11,9I6,8X/12I6,8X)	00076300
1016	FORMAT(2A4,1C,13,11,2I6,42X,8X)	00076400
1017	FORMAT(2A4,1C,13,11,3I6,36X,8X)	00076500
		00076600
C		00076700
2000	FORMAT(9H CBM101A ,A4,19F-UNKNOWN OPERATION.)	00076800
2001	FORMAT(30F CBM127A NO SPACE, CANNOT ADD ,2A4,1H.)	00076900
2002	FORMAT(8H CBM102A,14,35H, INVALID PANEL NUMBER FOR CONTROL ,2A4,	00077000
X	1H.)	00077100
2003	FORMAT(6H CBM103A,14,36H, INVALID VERTEX NUMBER FOR CONTROL ,2A4,	00077200
X	1H.)	00077300
2004	FORMAT(55F CBM104A Z NOT ZERO, PANEL & VERTEX NOW ZERO FOR POINT	00077400
X	,2A4,1H.)	00077500
2005	FORMAT(24F CBM105A NO NAME GIVEN, ,A4,1CH, 10NCRD.)	00077600
2006	FORMAT(9H CBM106A ,2A4,11F NOT FOUND.)	00077700
2007	FORMAT(54F CBM107A NUMBER OF PANELS/CONTROLS INVALID FOR MEMBER ,	00077800
X	2A4,1H.)	00077900
2008	FORMAT(9H CBM108A ,A1,2CF FOR X INVALID, MEMBER IS ,2A4,1H.)	00078000
2009	FORMAT(9H CBM109A ,A1,2CF FOR Y INVALID, MEMBER IS ,2A4,1H.)	00078100
2010	FORMAT(9H CBM110A ,A1,2CF FOR Z INVALID, MEMBER IS ,2A4,1H.)	00078200
2011	FORMAT(49H CBM111A X&Y, X&Z OR Y&Z ARE COLINEAR FOR MEMBER ,2A4)	00078300
2012	FORMAT(59F CBM112A DIRECTORY IS FULL, CANNOT ADD ,2A4,1H.)	00078400
2013	FORMAT(45H CBM113A PANEL IS ZERO, BUT POINT IS NOT FOR ,2A4,1H.)	00078500
2014	FORMAT(9H CBM114A ,2A4,1CF ALREADY EXISTS.)	00078600
2015	FORMAT(21F CBM115A END-OF-DATA.)	00078700
2016	FORMAT(28F CBM116A I/O ERROR ON RECORD,15,9F (INDEX).)	00078800
2017	FORMAT(28F CBM117A I/O ERROR ON RECORD,15,8F (DATA).)	00078900
2019	FORMAT(17F CBM119I MEMBER, ,2A4,5F, HAS,14,8H PANELS,,	00079000
I	4H AND,14,10F CONTROLS./	00079100
X	38H CBM120I COORDINATES ARE TRANSLATED TO,	00079200
X	2H (,F7.2,1H,,F7.2,1H,,F7.2,2H)./22F CBM121I COORDINATES G	00079300
X	8HIVEN AS ,A1,2H, ,A1,5H AND ,A1,21F ARE NOW F, L, AND U.)	

```

2020 FORMAT(8H CBM125A, I2, 39H IS AN INVALID NUMBER OF VERTICIES FOR , 00079400
X      2A4, 1H.) 00079500
2021 FORMAT(9H CBM1261 , 2A4, 9H PUNCHED.) 00079600
2022 FORMAT(9H CBM1291 , 2A4, 14H NOW IN PLACE.) 00079700
2023 FORMAT(9H CBM1281 , 2A4, 14H WAS IN PLACE.) 00079800
2024 FORMAT(9H CBM130A , 2A4, 15H USED IN PANELS, I4, 4H AND, I4, 1H.) 00079900
2025 FORMAT(9H CBM131A , 2A4, 20H HAS SAME NUMBER AS , 2A4, 1H.) 00080000
2026 FORMAT(9H CBM132A , 2A4, 21H IS A DUPLICATE NAME.) 00080100
2027 FORMAT(9H CBM133A , 2A4, 25H NOT PLANAR FOR VERTICIES, I2, 1H, , I2, 1H, , 00080200
X      I2, 4H AND, I2, 17H, DETERMINATE IS , E15.7) 00080300
2028 FORMAT(9H CBM134I , 2A4, 5H WITH, I5, 12H PANELS AND, , I5, 00080400
X      25H CONTROLS HAS BEEN ADDED.) 00080500
2029 FORMAT(9H CBM135A , 2A4, 17H NOT ADDED DUE TO, I5, 10H ERROR(S).) 00080600
2030 FORMAT(16H CBM136I MEMBER , 2A4, 9H CHECKED, , I5, 10H ERROR(S).) 00080700
2031 FORMAT(49H CBM137A DATABASE IS NOT A CREW STATION DATABASE.) 00080800
2032 FORMAT(27H CBM138I COMPRESS FINISHED.) 00080900
2033 FORMAT(28H CBM139I INVALID PANEL TYPE, , I4, 12H, FOR PANEL , 2A4, 00081000
X      20H. (PANEL INPUT CARD)) 00081100
2099 FORMAT(21H CBM122I PROGRAM END.) 00081200
      END 00081300

```

APPENDIX C-7  
 COMBIMAN SOURCE - IBMGLD LISTING

```

    TITLE 'IBMGLD'
IBMGLD CSECT
    SPACE 3
*****
*
** THE IBMGLD CSECT IS DESIGNED TO CONVERT IBM 2250 GRAPHIC ORDER
* PROGRAMS TO GOULD 'OR' CALCCMP TYPE PLOT ORDERS.
* IT IS CALLED BY GSPGLD, WHICH SUPPLIES THE 2250 BUFFER TABLE AND
* A COPY OF THE BUFFER IN MAIN STORAGE.
* IBMGLD CREATES A 9.5" BY 9.5" GOULD PLOT COPY OF THE 2250 SCREEN.
*
* FIRST WE WILL ISSUE A GETMAIN FOR A SAVE AREA FOR THIS ROUTINE,
* WHICH MAKES THIS ROUTINE RE-ENTRANT AND SERIALLY REUSABLE.
*****
    SPACE 3
    USING *,15 DEFINE BASE REG FOR REENTRANT STRT
    B 12(R0,R15) SKIP OVER THE ROUTINE NAME
    DC XL1'06' DEFINE NAME LENGTH
    DC C'IBMGLD' DEFINE NAME
    STM R14,R12,12(R13) STORE THE CALLING PROGS REGS
    CNLP 0,4
    BAL R1,*,8 SKIP OVER GETMAIN ARG LIST
    DC A(72) DEFINE LENGTH OF BYTES FOR SAVE AREA
    L R0,0(R1,R0) LOAD THE GETMAIN DATA INTO R0
    SVC 10 DC THE GETMAIN FOR A SAVE AREA
    ORCP 15 DROP R15 AS BASE
    SPACE 3
*****
*
* SAVE THE CALLING PROGS SAVE ADDRESSES IN THE SAVE AREA CHAIN.
*
*****
    SPACE 3
    LA R14,12(R13) LOAD PREV SAVE AREA ADDR
    ST R1,3(R13) STORE OUR SAVE AREA ADDR
    ST R13,4(R1) STORE CALL IN SAVE AREA ADDR IN OUR SAVE
    LR R13,R1 LOAD OUR SAVE AREA ADDRESS INTO THE SAVE REG
    LM R14,R1,0(R14) RELOAD THE LINKAGE REGISTERS
    BALK R12,0
    USING *,12 DEFINE OUR BASE REGISTER
    EJECT
*****
* REGISTER EQUATES
*****
R0 EQU 0
R1 EQU 1
R2 EQU 2 MAIN STORAGE BUFFER COPY
R3 EQU 3 BUFFER LENGTH/BUFFER RESTART ADDRESS
R4 EQU 4 BUFFER TABLE
R5 EQU 5
R6 EQU 6
R7 EQU 7
R8 EQU 8
R9 EQU 9
R10 EQU 10
R11 EQU 11
R12 EQU 12 BASE REGISTER
R13 EQU 13
R14 EQU 14
R15 EQU 15
FU EQU 0
  
```



```

INC      LA      R2,2(R2)      INCREMENT TO NEXT HALF WORD      00012300
        CR      R4,R2      SEE IF WE HAVE OVER RUN THE BUFFER      00012400
        BNL     CKNEXT      IF NOT GO CHECK THE NEXT HW      00012500
        B       ECBERR      IF SO GO INTO THE ERROR RETLRN MCDE      00012600
SPACE   3      00012700
*****
*          CHECK FOR REGENERATION TIMER,
*          BRANCH FOR PLOT ORDERS
*****      00012800
SPACE   3      00012900
GORDER  CLI     1(R2),X'E2'    SEE IF WE HAVE A GSRT CODE      00013000
        BL     PLTCRDR      LOWER CODE REQUIRES PLOT ACTION      00013100
        BH     BYPASS      IF HI WE CHECK FOR GTRU AND GCNDP CODES      00013200
        C      R2,GSRTADD     END IF WE HAVE LOOPEO      00013300
        BE     DUNE         00013400
        ST     R2,GSRTADD     SAVE THE GSRT ADDRESS      00013500
        B      INC          AND GO LOOK FOR NEXT ORDER      00013600
SPACE   3      00013700
*****
*          CHECK FOR BRANCHES(FF),
*          UPDATE R2 ACCORDING TO ORDER LENGTH
*****      00013800
SPACE   3      00013900
BYPASS  CLI     1(R2),X'FF'    Q. A GTRU CODE?      00014000
        BE     GTRU         A. YES. GO PROCCSS      00014100
        CLI     1(R2),X'CO'    Q. LESS THAN CO? CHECK FLR 83-87      00014200
        BL     INC          A. YES. GO PINT TO NEXT HALF WORD      00014300
        CLI     1(R2),X'Eb'    Q. LESS THAN EB? CHECK FCR CO & EA      00014400
        BL     FOUR        A. YES. GO PDINT TO NEXT WORD      00014500
        CLI     1(R2),X'FC'    Q. LESS THAN FC? CHECK FCR EB & EC      00014600
        BL     SIX         A. YES. GO POINT AWAY FROM 6 BYTES      00014700
FOUR    LA      R2,4(R2)      00014800
        B      CKNEXT      00014900
SIX     LA      R2,6(R2)      00015000
        B      CKNEXT      GO CHECK FOR THE NEXT ORDER CODE      00015100
EJECT  00015200
*****
*          CHECK TO SEE IF WE HAVE LOOPEO TO START,
*          IF SO END
*****      00015300
SPACE   3      00015400
GTRU   LH      R11,2(R2)      LOAD THE GTRU BRANCH ADCK      00015500
        C      R11,OFFSET    00015600
        BE     DUNE         00015700
        BAL     R14,CNVRT     00015800
        B      CKNEXT      00015900
SPACE   3      00016000
*****
*          TRANSLATE BUFFER ADDRESS TO MAIN
*          STORAGE ADDRESS
*****      00016100
SPACE   3      00016200
CNVRT  L       R2,START      LOAD START ADDRESS OF CORE      00016300
        L      R8,TABLE      LOAD BUFFER TABLE ADDRESS      00016400
GTLCCP LA      R6,4(R8)      INCREMENT BUFFER ADDRESS      00016500
        LH     R10,0(R3)     LOAD BUFFER ADDRESS      00016600
        LTP    R10,R10      CHECK FOR END OF TABLE      00016700
        BL     ECBERR      00016800
        LH     R9,2(R8)      LOAD LENGTH OF BUFFER SEGMENT      00016900
        AR     R10,R9        FIND LIMIT OF SEGMENT      00017000
        CR     R11,R10      CORRECT SEGMENT?      00017100
00017200
00017300
00017400
00017500
00017600
00017700
00017800
00017900
00018000
00018100
00018200
00018300

```

BNH	**+10		00018400
AR	R2,R9	UPDATE MAIN STORAGE POINTER	00018500
B	GTLOOP		00018600
SR	R10,R9	R10 POINTS TO SEGMENT START IN BUFFER	00018700
SR	R11,R10	R11 EQUALS OFFSET OF BRANCH ADDRESS	00018800
AR	R2,R11	NEW MAIN STORAGE POINTER	00018900
CR	R2,R4	SEE IF WE HAVE A END OF BUFFER ERROR	00019000
BH	EOBERR	IF SO PROCESS THE ERROR	00019100
BR	R14		00019200
EJECT			00019300
*****			
*	IF STOP REGENERATION ORDER,		00019400
*	THEN END		00019500
*****			
SPACE	3		00019600
PLTGRDR	CLI	1(R2),X'E0'	00019700
	INC	CHECK FOR A GNOF2 CODE	00019800
	BH	IF SO SKIP TO NEXT CODE	00019900
	CLI	WE HAVE AN END CROER SEQUENCE	00020000
	BL	CHECK FOR A TEST OR VECTOR COMMAND	00020100
	BL	IF LOW WE HAVE VECTORS	00020200
SPACE	3		00020300
*****			
*	PROCESS CHARACTER STRINGS		00020400
*****			
SPACE	3		00020500
LA	R5,2(R2)	COMPUTE THE ADDR OF THE 1ST CHARACTER	00020600
LA	R6,WORK	LOAD ADDRESS FC OUR WORK AREA	00020700
LI	CLI	0(P5),X'2A'	00020800
	BE	TEST FOR A NEW GRAPHICS COMMAND	00020900
	CLI	IF SO WE ARE AT END FC CHAR STRING	00021000
	BNE	U(R5),X'0C'	00021100
	SAVECH	TEST FOR A NULL CHARACTER	00021200
INCR5	LA	IF NOT THEN WE SAVE THIS CHAR	00021300
	CR	INCREMENT TO THE NEXT CHARACTER	00021400
	BNI	R4,R5	00021500
	B	CHECK FOR END OF BUFFER	00021600
	MVC	IF NOT ECB GC CHECK NEXT CHAR	00021700
	LA	OTHERWISE GO RETURN WITH ERROR INDICATION	00021800
	B	U(1,R6),C(R5)	00021900
	ENOC5	MOVE CHAR TO WORK AREA	00022000
	SRL	R6,1(R6)	00022100
	SLL	UNPDTE THE WORK AREA ADDRESS	00022200
	CR	GO UPDATE R5 AND CHECK NEXT CHAR	00022300
	BNE	R7,R5	00022400
	LA	SAVE REG 5	00022500
	SR	R7,1	00022600
	BNP	DIVIDE BY TWO	00022700
	STH	R7,1	00022800
	L	MULTIPLY BY 2	00022900
	LA	R7,R5	00023000
	TM	SEE IF WE LOST A BIT	00023100
	BZ	NE MEANS NOT CN HW BOUNDARY	00023200
	MVC	R7,WORK	00023300
	MVC	LOAD THE ADDRESS OF THE CHAR STRING	00023400
	B	COMPUTE THE NUMBER OF CHARS IN STRING	00023500
	SMALL	R6,R7	00023600
	MVC	DO NOT PROCESS 0 LENGTH STRINGS	00023700
	SE	LOAD2	00023800
	STE	R6,SYMLEN+2	00023900
	STE	STORE THE LENGTH IN THE SYMBOL RTN	00024000
	STE	R15,=V(SYMBOL)	00024100
	STE	LOAD THE ADDRESS FOR THE SYMBOL ROOT1	00024200
	STE	R1,SYMLIST	00024300
	STE	LOAD THE ARGUMENT LIST ADDRESS	00024400
SPACE	3		00024500
TM	1(R2),X'01'	TEST FOR CHARACTER SIZE	00024600
BZ	SMALL		00024700
MVC	HGT,LARGE	MUST NEED LARG CHARABTERS	00024800
MVC	HHT,H LARGE		00024900
B	SIMBCL	GC CALL SYMBOL	00025000
SMALL	MVC	NEED SMALL SIZE CHARACTERS	00025100
MVC	HGT,HBASIC		00025200
SIMBCL	SE	ADJUST FOR THE CHARACTER SPACING	00025300
	SE	F0,HGT	00025400
	SE	F2,HHT	00025500
	STE	DIFFERENCE BETWEEN GOULO & 2250	00025600
	STE	F0,X	00025700
	STE	STORE THE X POSITION VALUE	00025800
	STE	F2,Y	00025900
	STE	STORE THE Y POSITION VALUE	00026000

	BALR	R14,R15	CALL SYMBOL TO PLCT CHAR STRING	00024500
	LA	R1,WLST		00024600
	L	R15,=V(WHERE)	LOCATE BEAM POSITION	00024700
	BALR	R14,R15	AFTER PLGTTING	00024800
	LE	F0,X	RELOAD THE X POSITION REGISTER	00024900
	LE	F2,Y	RELOAD THE Y POSITION REGISTER	00025000
	AE	F0,HFGT		00025100
	AE	F2,HFGT		00025200
LOAD2	LR	R2,R5	UPDATE THE R2 ADDRESS	00025300
	B	CKNEXT		00025400
	EJECT			00025500
	*****			00025600
	*	PROCESS VECTORS/POINTS		00025700
	*****			00025800
	SPACE	3		00025900
VECTCRS	MVI	VSW1+1,C'0'	SET INCR MODE BYPASS SWITCH ON	00026000
	MVI	VSW2+1,C'0'	SET POINT LINE SWITCH TO LINE MODE	00026100
	CLI	1(R2),X'02'	TEST FOR A GEVM CODE	00026200
	BE	OPENSW2+4	IF SO SWITCHERS ARE OK	00026300
	BL	**+8	IFLCH WE HAVE POINTS WITH HW ABS VALUES	00026400
	MVI	VSW1+1,X'0'	SET SWITCH FOR INCR MODE	00026500
	CLI	1(R2),X'05'	TEST FOR POINT MODE INCR TYPE	00026600
	BE	**+8		00026700
CPENSW2	MVI	VSW2+1,X'00'	SET SWITCH FOR POINT PLCT MODE	00026800
	LA	R2,2(R2)	INCREMENT R2	00026900
	CR	R2,R4	CHECK FOR END OF BUFFER	00027000
	BH	EDBERK	IF SO PROCESS THE ERROR	00027100
	CLI	0(R2),X'2A'	CHECK FOR A NEW GRAPHICS ORDER	00027200
	BE	GORDER	IF SO GC PROCESS NEW COMMAND	00027300
	SR	R6,R6		00027400
	SR	R7,R7	CLEAR RR'S 6&7	00027500
VSW1	NOP		NOTING SWITCH FOR BYPASSING INCR VECTOR MODE	00027600
	LH	R6,0(R2)	LOAD THE X,Y,BEAM VALUES INTO R6	00027700
	SRDA	R6,5	SHIFT BEAM AND Y VALUES INTO R7	00027800
	SDR	F4,F4	CLEAR FLCAT REG 4	00027900
	MVI	FLTX,X'6A'	SET FOR A POSITIVE INCREMENT	00028000
	SLA	R6,2	MULTIPLY BY 4	00028100
	BH	FLTX-4	IF POSITIVE ADD IT INTO THE X REG	00028200
	BE	FLTX+10		00028300
	LPR	R6,R6	IF NEGATIVE MAKE IT POSITIVE	00028400
	MVI	FLTX,X'6B'	AND SET THE FLCAT FOR A SUBTRACTION	00028500
	ST	R6,FLTMP+4	STORE THE VALUE INTO TEMP FLOAT AREA	00028600
FLTX	AD	F4,FLTMP	FLCAT THE INCR VALUE INTO F4	00028700
	ME	F4,RU2SL	CONVERT TO PROPER CSAL SIZE	00028800
	AER	F0,F4	ADD IT TO THE X POSITION REG	00028900
	SDR	F0,F6	CLEAR FLCAT REG 6	00029000
	SLL	R7,1	REMOVE EXTRA BIT FROM Y VALUE	00029100
	SLDL	R6,7	MOVE Y VALUE INTO R6	00029200
	SLL	R6,25	SHIFT SIGN BIT INTO POSITION	00029300
	MVI	FLTY,X'6A'	SET FLOAT FOR A POS INCR	00029400
	SKA	R6,23	PROPAGATE SIGN BIT DOWN	00029500
	BH	FLTY-4	IF ALREADY POSITIVE GL PROCESS IT	00029600
	BE	FLTY+10		00029700
	MVI	FLTY,X'6B'	SET FOR MINUS INCREMENT	00029800
	LPR	R6,R6	RELOAD R6 WITH A POSITIVE VALUE	00029900
	ST	R6,FLTMP+4	STORE THE VALUE INTO TEMP FLOAT AREA	00030000
FLTY	AD	F6,FLTMP	FLCAT THE Y INCR VALUE INTO F6	00030100
	ME	F6,RU2SL	SCALE IT UP R SCAN LINES NOT RASTER UNITS	00030200
	AER	F2,F6	ADD THE INCREMENT TO THE Y POSITION REG	00030300
	SR	R6,R6	CLEAR REG 6	00030400
	SLDL	R6,1	MOVE BEAM INDICATOR INTO R6	00030500

	B	SET4PLT	GO PLCT THE VECTOR	00030600
NOTINC	LH	R7,0(R2)	LOAD THE X VALUE INTO R7	00030700
	SLDA	R6,18	MOVE BEAM INDICATOR INTO REG 6	00030800
	SRL	R7,18	READJUST THE X VALUE	00030900
	ST	R7,FLTMP+4	STORE THE VALUE INTO TEMP FLOAT AREA	00031000
	SOR	F0,F0	CLEAR THE X POSITION REGISTER	00031100
	AD	F0,FLTMP	LOAD IN THE NEW X POSITION	00031200
	ME	F0,RU2SL	SCALE IT FOR SCAN LINES NOT RASTER UNITS	00031300
	LA	R2,2(R2)	UPDATE THE REG Z ADDR	00031400
	SJR	F2,F2	CLEAR THE Y POSITION REGISTER	00031500
	LH	R7,0(R2)	LOAD THE Y VALUE INTO R7	00031600
	ST	R7,FLTMP+4	STORE THE VALUE INTO TEMP FLOAT AREA	00031700
	AD	F2,FLTMP	LOAD Y VALUE INTO THE Y POSITION REG	00031800
	ME	F2,RU2SL	SCALE IT FOR SCAN LINES NOT RASTER UNITS	00031900
SET4PLT	STE	F0,X	STORE THE X POSITION	00032000
	STE	F2,Y	STORE THE Y POSITION	00032100
	L	R15,=V(PLCT)	LOAD ADDRESS OF THE PLOT ROUTINE	00032200
	LA	R1,PLTLST	LOAD THE ARGUMENT LIST ADDRESS	00032300
	LA	R7,2	LOAD A Z INTO REG 7	00032400
VSw2	NOP	LINES	SKIP IF WE AREA IN LINE MODE	00032500
	MVI	IPEN+3,X*3'	SET IPEN TO OFF	00032600
	BALR	R14,R15	GO MOVE TO THE POINT FOR PLOT	00032700
	LE	F0,X	RELOAD THE X VALUE	00032800
	LE	F2,Y	RELOAD THE Y REG	00032900
	LTR	R6,R6	Q. A POINT TO BE PLOTTED?	00033000
	BNE	CPENSw2+4	A. NO. PROCESS NEXT VECTOR	00033100
	LA	R1,PLTLST2	A. YES. DOUBLE WEIGHT POINTS	00033200
	L	R15,=V(PLCT)		00033300
	BALR	R14,R15		00033400
	B	LOADFX	GO RELOAD FLOATING REGS	00033500
LINES	AR	R7,R6	COMPLETE THE IPEN CODE 1=	00033600
	ST	R7,IPEN	SAVE IT IN THE IPEN VALUE AREA	00033700
	LA	R1,PLTLST		00033800
	L	R15,=V(PLCT)		00033900
	BALR	R14,R15	GO CALL PLOT ROUTINE	00034000
LOADFX	LE	F0,X	RELOAD THE FLOATING REG F0	00034100
	LE	F2,Y	RELOAD THE FLOATING REG F2	00034200
	B	CPENSw2+4	GO TO PROCESS THE NEXT VECTOR	00034300
	EJECT			00034400
				00034500
				00034600
				00034700
				00034800
				00034900
				00035000
				00035100
				00035200
				00035300
				00035400
				00035500
				00035600
				00035700
				00035800
				00035900
				00036000
				00036100
				00036200
				00036300
				00036400
				00036500
				00036600

```

*****
*                               DATA DECLARATIONS I
*****
GSRTADD  DC      F'0'
*
OFFSET   DC      XL4'00003FFF'
*
SYMLEN   DC      H'0'
          DC      H'0'
*
ZERO     DC      F'0'
NEG1     DC      F'-1'
NEG3     DC      F'-3'
TWU      DC      F'2'
*
          SPACE  3
*****
*                               ARGUMENT LIST FOR
*                               SYMBOL
*****
          SPACE  3
SYMLIST  DC      A(X)

```



```

*****
XMAX      OC      E'10.0'
*
YMAX      DC      E'10.0'
*
FQUART    DC      E'0.25'
          SPACE   3
*****
*                ARGUMENT LIST FOR RESERV
*****
RSVARG5   DC      X'80'
          DC      AL3(K40)
*****
*                DATA DECLARATIONS IV
*****
K40       DC      F'40000'
SVELEN    OC      A(72)
*****
*                ARGUMENT LIST FOR WHERE
*****
WLST      OC      A(X)
          OC      A(Y)
          DC      X'80'
          OC      AL3(WORK)
          EJECT
*
DONE      MVI     RETCCDE,X'0'  CLEAR THE RETURN CODE VALUE
Z999     LA      R1,PLI1ST
          LA      R11,999
          ST      R11,IPEN          END PLOT
          SR      R11,R11
          ST      R11,X
          ST      R11,Y
          L       R15,=V(PLOT)
          BALR   R14,R15
          SR      R1,R1          CLEAR REG1
          L       R15,=V(CLSOUT)  LOAD ADDR OF CLSOUT ROUTINE
          BALR   R14,R15          GC CLOSE THE GOULE ROUTINES
          LA      R1,0(R13)
          L       R0,SVELEN
          L       R13,4(R13)      LOAD CALLING PRGCS RETURN ADDRESS
          SVC     10             EXECUTE THE FREEMAIN SVC
          LM      R14,R12,12(R13)  RELOAD CALLING PRGCS REGISTERS
          MVI     12(R13),X'FF'   SET RETURN INDICATOR
          LA      R15,0          SET RETURN CODE
          ORG     *-1             RE-ORIGIN FOR PUTTING RETCCDE INTO MVI INST
RETCCDE   DS      CL1           DEFINE SPACE FOR THE RETURN CODE IN MVI INST
          BR      R14            RETURN TO THE CALLING PROGRAM
EOBERR    MVI     RETCCDE,X'4'
          B       DONE+4
          SPACE  4
          ENC
*****
00042800
00042900
00043000
00043100
00043200
00043300
00043400
00043500
00043600
00043700
00043800
00043900
00044000
00044100
00044200
00044300
00044400
00044500
00044600
00044700
00044800
00044900
00045000
00045100
00045200
00045300
00045400
00045500
00045600
00045700
00045800
00045900
00046000
00046100
00046200
00046300
00046400
00046500
00046600
00046700
00046800
00046900
00047000
00047100
00047200
00047300
00047400
00047500
00047600
00047700
00047800
00047900

```

APPENDIX D

JCL AND DATA REQUIRED TO CREATE  
 67 USAF AND 70 ARMY SURVEY MEMBERS AND  
 R67 USAF AND R70 ARMY REGRESSION MEMBERS  
 OF THE COMBIMAN ANTHROPOMETRIC DATA BASE

```

//CBMAM      JOB HESS                                00001000
//JOB LIB    DD DSN=COMBIMAN.LOADLIB,DISP=SHR        00001100
//CBMAM      EXEC PGM=CBMAM                          00001200
//FT02F001  DD DSN=COMBIMAN.ANTHDATA,DISP=SHR        00001300
//FT02F001  DD DSN=COMBIMAN.ANTHDATA,UNIT=DISK,DISP=(NEW,CATLG),
//          VOL=SER=DISK01,SPACE=(248,200C),        00001310
//          DCB=(BLKSIZE=248,LRECL=248,RECFM=FB)    00001320
//FT05F001  DD DDNAME=SYSIN                          00001400
//FT06F001  DD SYSOUT=A                              00001500
//FT07F001  DD SYSOUT=B                              00001600
//SYSUDUMP   DD SYSOUT=A                              00001700
//SYS IN     DD *                                    00001800
+INT
  
```

MEMBER NAME USAF

+ADD R67 USAF		C	17	24	12			
1	WEIGHT		LB	1		1		00010000
2	SITTING HEIGHT		IN		1	1		00010100
3	EYE HGT/SITTING		IN		1			00010200
4	ACROMION HGT/SIT		IN			1		00010300
5	KNEE HGT/SITTING		IN		1	1		00010400
6	BUTTOCK-KNEE LGTH		IN		1	1		00010500
7	SHOULDER-ELB LGTH		IN			1		00010600
8	ELBOW-GRIP LGTH		IN		1			00010700
9	THUMB-TIP REACH		IN		1			00010800
10	BIACROMIAL BRDTH		IN			1		00010900
11	BIDELTIC BRDTH		IN	1				00011000
12	HIP BREADTH		IN			1		00011100
13	HIP BREADTH/SITT		IN	1				00011200
14	CHEST DEPTH		IN	1		1		00011300
15	FOOT LENGTH		IN			1		00011400
16	HAND LENGTH		IN			1		00011500
17	ELBOW-WRIST LGTH		IN			1		00011600
1	2	0.02069	32.05275	1.11161	7.84536-114.20831	19.05910		00011700
1	2	1	1.0	0.0		0.0		00011800
1	2	2	0.0	1.0000000		0.0		00011900
1	2	4		.731		-2.779522		00012000
1	2	5		.404		7.133844		00012100
1	2	6		.323		11.560906		00012200
1	2	7		.247		5.090541		00012300
1	2	10	0.0131732	0.1105000		9.05417		00012400
1	2	12	0.0279173	0.0043000		8.87957		00012500
1	2	14	0.0313031-0.1605000			10.32958		00012600
1	2	15	0.0069724	0.1246000		4.05466		00012700
1	2	16		.117		3.232277		00012800
1	2	17		.192		4.728337		00012900
1	3	0.02287	27.05850	1.00116	7.45657-04.02701	19.52158		00013000
1	3	1	1.0	0.0		0.0		00013100
1	3	2		0.979		5.484241		00013200
1	3	4		0.737		0.55118		00013300
1	3	5		.403		9.114155		00013400
1	3	6		.349		12.001392		00013500
1	3	7		.260		5.80013		00013600
1	3	10	0.0141614	0.0857000		10.84526		00013700
1	3	12	0.0270189	0.0093000		8.75802		00013800
1	3	14	0.0304921-0.1507000			9.41970		00013900
1	3	15	0.0075236	0.1215000		5.46532		00014000
1	3	16		.113		3.921252		00014100
1	3	17		.172		6.295203		00014200
1	5	0.02470	17.00050	0.82738	11.70173-04.01144	18.05449		00014300
1	5	1	1.0	0.0		0.0		00014400
1	5	2		.056		22.20342		00014500
1	5	4		.510		12.038557		00014600
1	5	5	0.0	1.0000000		0.0		00014700
1	5	6		.851		5.090415		00014800
1	5	7		.516		2.822825		00014900
1	5	10	0.0125030	0.1442000		10.008774		00015000
1	5	12	0.0202203-0.0081000			9.10118		00015100
1	5	14	0.0301090-0.1347000			7.37230		00015200
1	5	15	0.0030315	0.2947000		3.64051		00015300
1	5	16		.215		2.003144		00015400
1	5	17		.443		2.082073		00015500
1	0	0.03150	18.29894	0.82105	12.81257-131.00403	16.53998		00015600

## MEMBER NAME USAF

1 0 1	1.0	0.0	0.0	0.0				00015900
1 0 2		.460		25.744043				00015900
1 0 4		.358		15.523591				00016000
1 0 5		.725		4.712589				00016100
1 0 6	0.0	1.0000000	0.0	0.0				00016200
1 0 7		.442		3.641725				00016300
1 0 10	0.0158071	0.0097000		13.06010				00016400
1 0 12	0.0267293	0.0412000		8.26376				00016500
1 0 14	0.0293819	0.0755000		6.44566				00016600
1 0 15	0.0033780	0.2152000		4.84350				00016700
1 0 16		.165		3.596416				00016800
1 0 17		.327		4.031488				00016900
1 0	0.01212	11.75517		0.58148	13.73200	-16.71660	19.56918	00017000
1 8 1	1.0	0.0	0.0	0.0				00017100
1 8 2		.906		24.125936				00017200
1 8 4		.676		14.665262				00017300
1 8 5		1.206		5.240147				00017400
1 8 6		1.043		9.226753				00017500
1 8 7		.715		4.244066				00017600
1 8 10	0.0132520	0.2362000		10.46027				00017700
1 8 12	0.0278150	0.0176000		6.81113				00017800
1 8 14	0.0287244	0.1528000		6.78296				00017900
1 8 15	0.0053740	0.4061000		4.08147				00018000
1 8 16		.359		2.547239				00018100
1 8 17		.785		.929132				00018200
1 9	0.03029	26.35823		1.42212	5.66767	-5.56512	19.50635	00018300
1 9 1	1.0	0.0	0.0	0.0				00018400
1 9 2		.330		26.251916				00018500
1 9 4		.250		16.133626				00018600
1 9 5		.429		8.074787				00018700
1 9 6		.410		10.816876				00018800
1 9 7		.251		4.952746				00018900
1 9 10	0.0136611	0.0805000		11.11438				00019000
1 9 12	0.0261893	0.0046000		5.13904				00019100
1 9 14	0.0276446	0.0362000		5.94550				00019200
1 9 15	0.0063701	0.1298000		5.43332				00019300
1 9 16		.119		3.759635				00019400
1 9 17		.243		4.125976				00019500
11 2	0.34507	30.12037		1.20046	0.22538	10.72527	0.96934	00019600
11 2 1	16.9568	0.0	-148.083	0.0				00019700
11 2 2	0.0	1.0000000	0.0	0.0				00019800
11 2 4		.721		-2.779522				00019900
11 2 5		.404		7.133644				00020000
11 2 6		.333		11.566906				00020100
11 2 7		.247		5.090541				00020200
11 2 10	0.4600000	0.1104000		3.24965				00020300
11 2 12	0.4125000	0.1303000		1.26161				00020400
11 2 14	0.4789000	0.0286000		1.61592				00020500
11 2 15	0.0873000	0.1595000		3.12040				00020600
11 2 16		.117		3.232277				00020700
11 2 17		.193		4.726337				00020800
11 3	0.30610	26.05530		1.14619	0.22134	11.93966	0.97466	00020900
11 3 1	16.9568	0.0	-148.083	0.0				00021000
11 3 2		0.979		5.464241				00021100
11 3 4		0.737		0.55118				00021200
11 3 5		.403		9.114155				00021300
11 3 6		.349		12.661392				00021400
11 3 7		.260		5.86613				00021500

## MEMBER NAME USAF

11	3	10	0.4715000	0.0869000	4.31225				00021800
11	3	12	0.4201000	0.1234000	1.97291				00021700
11	3	14	0.4808000	-0.0381000	1.74185				00021800
11	3	15	0.0945000	0.1566000	3.85737				00021900
11	3	16		.113	3.521252				00022000
11	3	17		.173	6.255263				00022100
11	5		0.33106	15.65472	0.92347	0.35026	11.30361	0.94902	00022200
11	5	1	16.9568	0.0	-148.083				00022300
11	5	2		.653	22.28342				00022400
11	5	4		.510	12.83855				00022500
11	5	5	0.0	1.0	0.0				00022600
11	5	6		.851	5.058415				00022700
11	5	7		.510	2.822829				00022800
11	5	10	0.4540000	0.1333000	4.48622				00022900
11	5	12	0.3565000	0.1854000	2.28117				00023000
11	5	14	0.4478000	0.0640000	-0.25567				00023100
11	5	15	0.0576000	0.3172000	2.96457				00023200
11	5	16		.215	2.805174				00023300
11	5	17		.443	2.082673				00023400
11	6		0.48362	14.97491	0.95564	0.41724	9.07114	0.90058	00023500
11	6	1	16.9568	0.0	-148.083				00023600
11	6	2		.460	25.74404				00023700
11	6	4		.358	15.52359				00023800
11	6	5		.725	4.712589				00023900
11	6	6	0.0	1.0000000	0.0				00024000
11	6	7		.442	3.641725				00024100
11	6	10	0.4949000	0.0068000	8.47457				00024200
11	6	12	0.3472000	0.2399000	1.58527				00024300
11	6	14	0.4105000	0.1268000	-1.15616				00024400
11	6	15	0.0263000	0.2516000	4.15868				00024500
11	6	16		.165	3.592418				00024600
11	6	17		.327	4.031488				00024700
11	8		0.15366	18.84653	0.61644	0.39855	13.46951	0.97702	00024800
11	8	1	16.9568	0.0	-148.083				00024900
11	8	2		.906	24.12593				00025000
11	8	4		.676	14.66926				00025100
11	8	5		1.206	5.240147				00025200
11	8	6		1.043	9.326753				00025300
11	8	7		.715	4.244086				00025400
11	8	10	0.4008000	0.2348000	4.02853				00025500
11	8	12	0.4209000	0.2326000	2.66465				00025600
11	8	14	0.4596000	0.0593000	0.10500				00025700
11	8	15	0.0708000	0.4518000	3.03617				00025800
11	8	16		.359	2.547239				00025900
11	8	17		.785	.929132				00026000
11	9		0.45448	23.36423	1.50431	0.18032	13.29244	0.90911	00026100
11	9	1	16.9568	0.0	-148.083				00026200
11	9	2		.320	26.25191				00026300
11	9	4		.250	16.13362				00026400
11	9	5		.429	8.074787				00026500
11	9	6		.410	10.81887				00026600
11	9	7		.291	4.952746				00026700
11	9	10	0.4699000	0.0744000	4.83476				00026800
11	9	12	0.4237000	0.0790000	3.34054				00026900
11	9	14	0.4512000	0.0413000	-0.21794				00027000
11	9	15	0.0767000	0.1521000	4.37728				00027100
11	9	16		.119	3.759635				00027200
11	9	17		.243	4.125976				00027300

MEMBER NAME USAF

13 2		0.46318	29.79372	1.17767	0.24312	5.96086	0.65322	00027400
13 2 1	20.2776	0.0		-127.757				00027500
13 2 2	0.0	1.000000		0.0				00027600
13 2 4		.731		-2.779522				00027700
13 2 5		.404		7.133844				00027800
13 2 6		.323		11.566906				00027900
13 2 7		.247		5.090541				00028000
13 2 10	0.1935000	0.1669000		7.03065				00028100
13 2 12	0.7167000	0.0498000		1.39459				00028200
13 2 14	0.5539000	0.0551000		3.43517				00028300
13 2 15	0.1106000	0.1527000		3.39454				00028400
13 2 16		.117		3.232277				00028500
13 2 17		.193		4.726337				00028600
13 3	0.40811	25.79650		1.12810	0.25757	7.30687	0.66072	00028700
13 3 1	20.2776	0.0		-127.757				00028800
13 3 2		0.979		5.484241				00028900
13 3 4		0.737		0.55118				00029000
13 3 5		.403		9.114155				00029100
13 3 6		.349		12.661392				00029200
13 3 7		.260		5.86613				00029300
13 3 10	0.2134000	0.1408000		8.37065				00029400
13 3 12	0.7207000	0.0468000		1.67072				00029500
13 3 14	0.5537000	0.0621000		3.39631				00029600
13 3 15	0.1206000	0.1491000		4.09600				00029700
13 3 16		.113		3.921252				00029800
13 3 17		.173		6.295263				00029900
13 5	0.44387	15.34930		0.89625	0.37738	6.59500	0.62641	00030000
13 5 1	20.2776	0.0		-127.757				00030100
13 5 2		.656		22.28342				00030200
13 5 4		.510		12.83055				00030300
13 5 5	0.0	1.0		0.0				00030400
13 5 6		.851		5.098415				00030500
13 5 7		.516		2.822829				00030600
13 5 10	0.1694000	0.2281000		8.50694				00030700
13 5 12	0.7157000	0.0540000		2.04980				00030800
13 5 14	0.5175000	0.0253000		1.40055				00030900
13 5 15	0.0417000	0.3146000		3.11505				00031000
13 5 16		.215		2.803144				00031100
13 5 17		.443		2.062673				00031200
13 6	0.64324	14.26918		0.89041	0.46605	3.79715	0.75792	00031300
13 6 1	20.2776	0.0		-127.757				00031400
13 6 2		.460		25.74404				00031500
13 6 4		.358		15.52359				00031600
13 6 5		.725		4.712569				00031700
13 6 6	0.0	1.0		0.0				00031800
13 6 7		.442		3.669475				00031900
13 6 10	0.1909000	0.1234000		10.25960				00032000
13 6 12	0.7041000	0.0552000		2.09503				00032100
13 6 14	0.4824000	0.0720000		0.76467				00032200
13 6 15	0.0173000	0.2545000		4.33329				00032300
13 6 16		.165		3.598418				00032400
13 6 17		.327		4.631488				00032500
13 8	0.20220	10.85128		0.61001	0.40891	9.21256	0.66749	00032600
13 8 1	20.2776	0.0		-127.757				00032700
13 8 2		.906		24.12593				00032800
13 8 4		.676		14.66926				00032900
13 8 5		1.206		5.240147				00033000
13 8 6		1.043		9.326753				00033100

## MEMBER NAME USAF

13	8	7		.715	4.244086				00033200
13	8	10	0.2023000	0.3355000	8.37363				00033300
13	8	12	0.7182000	0.1055000	1.73571				00033400
12	8	14	0.5230000	0.0277000	1.48880				00033500
13	8	15	0.0913000	0.4426000	3.15125				00033600
13	8	16		.359	2.547239				00033700
13	8	17		.785	.925132				00033800
13	9		0.51279	23.98011	1.49653	0.17133	9.46310	0.80504	00033900
13	9	1	20.2770	0.0	-127.757				00034000
13	9	2		.330	26.25191				00034100
13	9	4		.250	10.13382				00034200
13	9	5		.439	8.074787				00034300
13	9	6		.410	10.81887				00034400
13	9	7		.291	4.952746				00034500
13	9	10	0.2075000	0.1224000	9.07808				00034600
13	9	12	0.7238000	0.0308000	2.14232				00034700
13	9	14	0.5110000	0.0345000	0.56138				00034800
13	9	15	0.1050000	0.1479000	4.40562				00034900
13	9	16		.119	3.759835				00035000
13	9	17		.243	4.157416				00035100
14	2		0.21453	34.61474	1.23950	0.07920	6.74895	0.75510	00035200
14	2	1	21.4816	0.0	-33.422				00035300
14	2	2	0.0	1.0000000	0.0				00035400
14	2	4		.731	-2.779522				00035500
14	2	5		.404	7.133844				00035600
14	2	6		.333	11.500900				00035700
14	2	7		.247	5.090541				00035800
14	2	10	0.2285000	0.1957000	0.64776				00035900
14	2	12	0.5291000	0.1614000	2.12145				00036000
14	2	14	1.0000000	0.0	0.0				00036100
14	2	15	0.1140000	0.1704000	3.28406				00036200
14	2	16		.117	3.232277				00036300
14	2	17		.193	4.726237				00036400
14	3		0.16752	30.25192	1.18027	0.06858	7.46870	0.75520	00036500
14	3	1	21.4816	0.0	-33.422				00036600
14	3	2		0.979	5.484241				00036700
14	3	4		0.737	0.55116				00036800
14	3	5		.403	9.114155				00036900
14	3	6		.349	12.601392				00037000
14	3	7		.260	5.80613				00037100
14	3	10	0.2413000	0.1740000	8.14076				00037200
14	3	12	0.5379000	0.1790000	2.96665				00037300
14	3	14	1.0000000	0.0	0.0				00037400
14	3	15	0.1229000	0.1691000	4.06737				00037500
14	3	16		.113	3.921252				00037600
14	3	17		.175	0.295253				00037700
14	5		0.30704	18.41054	0.94189	0.21947	4.65001	0.72654	00037800
14	5	1	21.4816	0.0	-33.422				00037900
14	5	2		.056	22.28342				00038000
14	5	4		.510	12.03855				00038100
14	5	5	0.0	1.0000000	0.0				00038200
14	5	6		.851	5.098415				00038300
14	5	7		.510	2.822629				00038400
14	5	10	0.1770000	0.2529000	8.77199				00038500
14	5	12	0.4880000	0.2164000	4.42040				00038600
14	5	14	1.0000000	0.0	0.0				00038700
14	5	15	0.0317000	0.3254000	3.23744				00038800
14	5	16		.215	2.803144				00038900

MEMBER NAME USAF

14	5	17		.443		2.082673					00039000
14	6		0.52391	18.14341		0.96724	0.29754	2.57075	0.69045		00039100
14	6	1	21.4816	0.0		-33.422					00039200
14	6	2		.460		25.74404					00039300
14	6	4		.358		15.52355					00039400
14	6	5		.725		4.712589					00039500
14	6	6	0.0	1.0000000		0.0					00039600
14	6	7		.442		3.641725					00039700
14	6	10	0.1769000	0.1600000		10.52173					00039800
14	6	12	0.4150000	0.2600000		3.67241					00039900
14	6	14	1.0000000	0.0		0.0					00040000
14	6	15	-0.0028000	0.2634000		4.40554					00040100
14	6	16		.165		3.596418					00040200
14	6	17		.327		4.03148E					00040300
14	8		0.16829	12.23530		0.62395	0.23936	6.33009	0.74412		00040400
14	8	1	21.4816	0.0		-33.422					00040500
14	8	2		.906		24.12593					00040600
14	8	4		.676		14.66926					00040700
14	8	5		1.206		5.240147					00040800
14	8	6		1.043		9.326753					00040900
14	8	7		.715		4.244086					00041000
14	8	10	0.2075000	0.3683000		8.92597					00041100
14	8	12	0.5211000	0.2741000		5.05256					00041200
14	8	14	1.0000000	0.0		0.0					00041300
14	8	15	0.0721000	0.4625000		3.53542					00041400
14	8	16		.359		2.547239					00041500
14	8	17		.785		.929132					00041600
14	9		0.51900	26.59757		1.51637	0.12210	5.79212	0.73507		00041700
14	9	1	21.4816	0.0		-33.422					00041800
14	9	2		.330		26.25191					00041900
14	9	4		.250		16.13382					00042000
14	9	5		.439		3.074787					00042100
14	9	6		.410		10.81007					00042200
14	9	7		.291		4.952746					00042300
14	9	10	0.2008000	0.1334000		9.67646					00042400
14	9	12	0.5202000	0.0914000		5.97084					00042500
14	9	14	1.0000000	0.0		0.0					00042600
14	9	15	0.0690000	0.1574000		4.99869					00042700
14	9	16		.119		3.759635					00042800
14	9	17		.243		4.125976					00042900
+ACC	07	USAF	1	17	24	12	25	AC7	USAF		00043000
1	2	3	5101520253035404550556065707580859095979099								00043100
1	WEIGHT			173.60686	21.43470	4127561326313562140151466915153500043200					00043200
15	52715850161501643716708169741724217513177521600418397107411913219591										00043300
2018521076216622209422773											00043400
2	SITTING HEIGHT	IN	36.685532	1.2501624	3394	3424	3444	3470	3511	3539	00043500
3532	3582	3600	3617	3633	3649	3665	3681	3698	3715	3733	00043600
3753	3773	3800	3810	3831	3862						00043700
3	EYE HGT/SITTING	IN	31.669176	1.1671142	2917	2950	2971	2996	3038	3065	00043800
3067	3100	3123	3138	3153	3168	3183	3198	3213	3229	3246	00043900
3265	3286	3311	3343	3478							00044000
4	AUCUMION HGT/SIT	IN	24.03621	1.123410	2142	2177	2197	2224	2263	2287	00044100
2310	2327	2343	2358	2373	2387	2401	2415	2430	2445	2461	00044200
2479	2499	2522	2551	2594	2620	2639	2666				00044300
5	KNEE HGT/SITTING	IN	21.95673	.98041	1973	1998	2015	2037	2071	2095	00044400
2113	2129	2143	2157	2169	2194	2206	2219	2231	2245	2260	00044500
2277	2296	2322	2300	2336	2405	2436					00044600
6	OUTLICK-KNEE LGTH	IN	23.76431	1.06204	2136	2165	2163	2207	2244	2269	00044700

## MEMBER NAME USAF

2289	2306	2322	2336	2350	2363	2376	2389	2402	2416	2431	2447	2465	2486	00044800
2514	2557	2587	2610	2648										00044900
7	SHOULDER-ELB LGTH IN 14.15382 .674011 1265 1281 1291 1306 1329 1345 1360 1375 1390 1405 1420 00045000													
1357	1368	1379	1388	1397	1406	1414	1423	1432	1441	1451	1461	1473	1486	00045100
1503	1528	1544	1555	1573										00045200
8	ELBOW-GRIP LGTH IN 13.86133 .63554 1247 1261 1270 1283 1304 1319 1330 1341 1352 1363 1374 1385 00045300													
1331	1342	1351	1360	1369	1377	1385	1393	1401	1410	1419	1429	1440	1452	00045400
1469	1493	1509	1521	1540										00045500
9	THUMB-TIP REACH IN 31.62047 1.56498 2804 2846 2872 2908 2964 3010 3056 3100 3120 3139 3158 3178 3198 3218 3240 3264 3291 3322 00045600													
3030	3056	3079	3100	3120	3139	3158	3178	3198	3218	3240	3264	3291	3322	00045700
3364	3427	3469	3502	3555										00045800
10	BIACROMIAL BRDTH IN 16.03454 .764311 1418 1441 1456 1475 1505 1520 1530 1540 1550 1560 1570 1580 1590 1600 1610 1620 1630 1640 1650 1660 1670 1680 1690 1700 00045900													
1541	1554	1566	1576	1586	1596	1605	1614	1624	1633	1643	1654	1666	1680	00046000
1698	1726	1744	1758	1782										00046100
11	BIDELTIOD BRDTH IN 18.99046 1.00841 1667 1696 1714 1737 1772 1795 1810 1825 1840 1855 1870 1885 1900 1915 1930 1945 1960 1975 1990 2005 2020 2035 2050 2065 2080 2095 2110 2125 2140 2155 2170 2185 2200 2215 2230 2245 2260 2275 2290 2305 2320 2335 2350 2365 2380 2395 2410 2425 2440 2455 2470 2485 2500 2515 2530 2545 2560 2575 2590 2605 2620 2635 2650 2665 2680 2695 2710 2725 2740 2755 2770 2785 2800 2815 2830 2845 2860 2875 2890 2905 2920 2935 2950 2965 2980 2995 3010 3025 3040 3055 3070 3085 3100 3115 3130 3145 3160 3175 3190 3205 3220 3235 3250 3265 3280 3295 3310 3325 3340 3355 3370 3385 3400 3415 3430 3445 3460 3475 3490 3505 3520 3535 3550 3565 3580 3595 3610 3625 3640 3655 3670 3685 3700 3715 3730 3745 3760 3775 3790 3805 3820 3835 3850 3865 3880 3895 3910 3925 3940 3955 3970 3985 4000 4015 4030 4045 4060 4075 4090 4105 4120 4135 4150 4165 4180 4195 4210 4225 4240 4255 4270 4285 4300 4315 4330 4345 4360 4375 4390 4405 4420 4435 4450 4465 4480 4495 4510 4525 4540 4555 4570 4585 4600 4615 4630 4645 4660 4675 4690 4705 4720 4735 4750 4765 4780 4795 4810 4825 4840 4855 4870 4885 4900 4915 4930 4945 4960 4975 4990 5005 5020 5035 5050 5065 5080 5095 5110 5125 5140 5155 5170 5185 5200 5215 5230 5245 5260 5275 5290 5305 5320 5335 5350 5365 5380 5395 5410 5425 5440 5455 5470 5485 5500 5515 5530 5545 5560 5575 5590 5605 5620 5635 5650 5665 5680 5695 5710 5725 5740 5755 5770 5785 5800 5815 5830 5845 5860 5875 5890 5905 5920 5935 5950 5965 5980 5995 6010 6025 6040 6055 6070 6085 6100 6115 6130 6145 6160 6175 6190 6205 6220 6235 6250 6265 6280 6295 6310 6325 6340 6355 6370 6385 6400 6415 6430 6445 6460 6475 6490 6505 6520 6535 6550 6565 6580 6595 6610 6625 6640 6655 6670 6685 6700 6715 6730 6745 6760 6775 6790 6805 6820 6835 6850 6865 6880 6895 6910 6925 6940 6955 6970 6985 6995 7010 7025 7040 7055 7070 7085 7100 7115 7130 7145 7160 7175 7190 7205 7220 7235 7250 7265 7280 7295 7310 7325 7340 7355 7370 7385 7400 7415 7430 7445 7460 7475 7490 7505 7520 7535 7550 7565 7580 7595 7610 7625 7640 7655 7670 7685 7700 7715 7730 7745 7760 7775 7790 7805 7820 7835 7850 7865 7880 7895 7910 7925 7940 7955 7970 7985 7995 8010 8025 8040 8055 8070 8085 8100 8115 8130 8145 8160 8175 8190 8205 8220 8235 8250 8265 8280 8295 8310 8325 8340 8355 8370 8385 8400 8415 8430 8445 8460 8475 8490 8505 8520 8535 8550 8565 8580 8595 8610 8625 8640 8655 8670 8685 8700 8715 8730 8745 8760 8775 8790 8805 8820 8835 8850 8865 8880 8895 8910 8925 8940 8955 8970 8985 8995 9010 9025 9040 9055 9070 9085 9100 9115 9130 9145 9160 9175 9190 9205 9220 9235 9250 9265 9280 9295 9310 9325 9340 9355 9370 9385 9400 9415 9430 9445 9460 9475 9490 9505 9520 9535 9550 9565 9580 9595 9610 9625 9640 9655 9670 9685 9700 9715 9730 9745 9760 9775 9790 9805 9820 9835 9850 9865 9880 9895 9910 9925 9940 9955 9970 9985 10000 10015 10030 10045 10060 10075 10090 10105 10120 10135 10150 10165 10180 10195 10210 10225 10240 10255 10270 10285 10300 10315 10330 10345 10360 10375 10390 10405 10420 10435 10450 10465 10480 10495 10510 10525 10540 10555 10570 10585 10600 10615 10630 10645 10660 10675 10690 10705 10720 10735 10750 10765 10780 10795 10810 10825 10840 10855 10870 10885 10900 10915 10930 10945 10960 10975 10990 11005 11020 11035 11050 11065 11080 11095 11110 11125 11140 11155 11170 11185 11200 11215 11230 11245 11260 11275 11290 11305 11320 11335 11350 11365 11380 11395 11410 11425 11440 11455 11470 11485 11500 11515 11530 11545 11560 11575 11590 11605 11620 11635 11650 11665 11680 11695 11710 11725 11740 11755 11770 11785 11800 11815 11830 11845 11860 11875 11890 11905 11920 11935 11950 11965 11980 11995 12010 12025 12040 12055 12070 12085 12100 12115 12130 12145 12160 12175 12190 12205 12220 12235 12250 12265 12280 12295 12310 12325 12340 12355 12370 12385 12400 12415 12430 12445 12460 12475 12490 12505 12520 12535 12550 12565 12580 12595 12610 12625 12640 12655 12670 12685 12700 12715 12730 12745 12760 12775 12790 12805 12820 12835 12850 12865 12880 12895 12910 12925 12940 12955 12970 12985 12995 13010 13025 13040 13055 13070 13085 13100 13115 13130 13145 13160 13175 13190 13205 13220 13235 13250 13265 13280 13295 13310 13325 13340 13355 13370 13385 13400 13415 13430 13445 13460 13475 13490 13505 13520 13535 13550 13565 13580 13595 13610 13625 13640 13655 13670 13685 13700 13715 13730 13745 13760 13775 13790 13805 13820 13835 13850 13865 13880 13895 13910 13925 13940 13955 13970 13985 13995 14010 14025 14040 14055 14070 14085 14100 14115 14130 14145 14160 14175 14190 14205 14220 14235 14250 14265 14280 14295 14310 14325 14340 14355 14370 14385 14400 14415 14430 14445 14460 14475 14490 14505 14520 14535 14550 14565 14580 14595 14610 14625 14640 14655 14670 14685 14700 14715 14730 14745 14760 14775 14790 14805 14820 14835 14850 14865 14880 14895 14910 14925 14940 14955 14970 14985 14995 15010 15025 15040 15055 15070 15085 15100 15115 15130 15145 15160 15175 15190 15205 15220 15235 15250 15265 15280 15295 15310 15325 15340 15355 15370 15385 15400 15415 15430 15445 15460 15475 15490 15505 15520 15535 15550 15565 15580 15595 15610 15625 15640 15655 15670 15685 15700 15715 15730 15745 15760 15775 15790 15805 15820 15835 15850 15865 15880 15895 15910 15925 15940 15955 15970 15985 15995 16010 16025 16040 16055 16070 16085 16100 16115 16130 16145 16160 16175 16190 16205 16220 16235 16250 16265 16280 16295 16310 16325 16340 16355 16370 16385 16400 16415 16430 16445 16460 16475 16490 16505 16520 16535 16550 16565 16580 16595 16610 16625 16640 16655 16670 16685 16700 16715 16730 16745 16760 16775 16790 16805 16820 16835 16850 16865 16880 16895 16910 16925 16940 16955 16970 16985 16995 17010 17025 17040 17055 17070 17085 17100 17115 17130 17145 17160 17175 17190 17205 17220 17235 17250 17265 17280 17295 17310 17325 17340 17355 17370 17385 17400 17415 17430 17445 17460 17475 17490 17505 17520 17535 17550 17565 17580 17595 17610 17625 17640 17655 17670 17685 17700 17715 17730 17745 17760 17775 17790 17805 17820 17835 17850 17865 17880 17895 17910 17925 17940 17955 17970 17985 17995 18010 18025 18040 18055 18070 18085 18100 18115 18130 18145 18160 18175 18190 18205 18220 18235 18250 18265 18280 18295 18310 18325 18340 18355 18370 18385 18400 18415 18430 18445 18460 18475 18490 18505 18520 18535 18550 18565 18580 18595 18610 18625 18640 18655 18670 18685 18700 18715 18730 18745 18760 18775 18790 18805 18820 18835 18850 18865 18880 18895 18910 18925 18940 18955 18970 18985 18995 19010 19025 19040 19055 19070 19085 19100 19115 19130 19145 19160 19175 19190 19205 19220 19235 19250 19265 19280 19295 19310 19325 19340 19355 19370 19385 19400 19415 19430 19445 19460 19475 19490 19505 19520 19535 19550 19565 19580 19595 19610 19625 19640 19655 19670 19685 19700 19715 19730 19745 19760 19775 19790 19805 19820 19835 19850 19865 19880 19895 19910 19925 19940 19955 19970 19985 19995 20010 20025 20040 20055 20070 20085 20100 20115 20130 20145 20160 20175 20190 20205 20220 20235 20250 20265 20280 20295 20310 20325 20340 20355 20370 20385 20400 20415 20430 20445 20460 20475 20490 20505 20520 20535 20550 20565 20580 20595 20610 20625 20640 20655 20670 20685 20700 20715 20730 20745 20760 20775 20790 20805 20820 20835 20850 20865 20880 20895 20910 20925 20940 20955 20970 20985 20995 21010 21025 21040 21055 21070 21085 21100 21115 21130 21145 21160 21175 21190 21205 21220 21235 21250 21265 21280 21295 21310 21325 21340 21355 21370 21385 21400 21415 21430 21445 21460 21475 21490 21505 21520 21535 21550 21565 21580 21595 21610 21625 21640 21655 21670 21685 21700 21715 21730 21745 21760 21775 21790 21805 21820 21835 21850 21865 21880 21895 21910 21925 21940 21955 21970 21985 21995 22010 22025 22040 22055 22070 22085 22100 22115 22130 22145 22160 22175 22190 22205 22220 22235 22250 22265 22280 22295 22310 22325 22340 22355 22370 22385 22400 22415 22430 22445 22460 22475 22490 22505 22520 22535 22550 22565 22580 22595 22610 22625 22640 22655 22670 22685 22700 22715 22730 22745 22760 22775 22790 22805 22820 22835 22850 22865 22880 22895 22910 22925 22940 22955 22970 22985 22995 23010 23025 23040 23055 23070 23085 23100 23115 23130 23145 23160 23175 23190 23205 23220 23235 23250 23265 23280 23295 23310 23325 23340 23355 23370 23385 23400 23415 23430 23445 23460 23475 23490 23505 23520 23535 23550 23565 23580 23595 23610 23625 23640 23655 23670 23685 23700 23715 23730 23745 23760 23775 23790 23805 23820 23835 23850 23865 23880 23895 23910 23925 23940 23955 23970 23985 23995 24010 24025 24040 24055 24070 24085 24100 24115 24130 24145 24160 24175 24190 24205 24220 24235 24250 24265 24280 24295 24310 24325 24340 24355 24370 24385 24400 24415 24430 24445 24460 24475 24490 24505 24520 24535 24550 24565 24580 24595 24610 24625 24640 24655 24670 24685 24700 24715 24730 24745 24760 24775 24790 24805 24820 24835 24850 24865 24880 24895 24910 24925 24940 24955 24970 24985 24995 25010 25025 25040 25055 25070 25085 25100 25115 25130 25145 25160 25175 25190 25205 25220 25235 25250 25265 25280 25295 25310 25325 25340 25355 25370 25385 25400 25415 25430 25445 25460 25475 25490 25505 25520 25535 25550 25565 25580 25595 25610 25625 25640 25655 25670 25685 25700 25715 25730 25745 25760 25775 25790 25805 25820 25835 25850 25865 25880 25895 25910 25925 25940 25955 25970 25985 25995 26010 26025 26040 26055 26070 26085 26100 26115 26130 26145 26160 26175 26190 26205 26220 26235 26250 26265 26280 26295 26310 26325 26340 26355 26370 26385 26400 26415 26430 26445 26460 26475 26490 26505 26520 26535 26550 26565 26580 26595 26610 26625 26640 26655 26670 26685 26700 26715 26730 26745 26760 26775 26790 26805 26820 26835 26850 26865 26880 26895 26910 26925 26940 26955 26970 26985 26995 27010 27025 27040 27055 27070 27085 27100 27115 27130 27145 27160 27175 27190 27205 27220 27235 27250 27265 27280 27295 27310 27325 27340 27355 27370 27385 27400 27415 27430 27445 27460 27475 27490 27505 27520 27535 27550 27565 27580 27595 27610 27625 27640 27655 27670 27685 27700 27715 27730 27745 27760 27775 27790 27805 27820 27835 27850 27865 27880 27895 27910 27925 27940 27955 27970 27985 27995 28010 28025 28040 28055 28070 28085 28100 28115 28130 28145 28160 28175 28190 28205 28220 28235 28250 28265 28280 28295 28310 28325 28340 28355 28370 28385 28400 28415 28430 28445 28460 28475 28490 28505 28520 28535 28550 28565 28580 28595 28610 28625 28640 28655 28670 28685 28700 28715 28730 28745 28760 28775 28790 28805 28820 28835 28850 28865 28880 28895 28910 28925 28940 28955 28970 28985 28995 29010 29025 29040 29055 29070 29085 29100 29115 29130 29145 29160 29175 29190 29205 29220 29235 29250 29265													

APPENDIX E

JCL AND DATA REQUIRED TO CREATE THE  
COMBIMAN CREW STATION DATA BASE MEMBER A7E-01

```
//CBMCM      JOB HESS                                00001000
//JOB LIB    DD DSN=COMBIMAN.LOADLIB,DISP=SHR        00001100
//CBMCM      EXEC PGM=CBMCM                          00001200
//FT01F001  DD OSN=COMBIMAN.CRSTDATA,UNIT=DISK,UI SP=(NEW,CATLG), 00001300
//           VOL=SER=DISK01,SPACE=(368,2000),        00001310
//           DCB=(BLKSIZE=368,LRECL=368,RECFM=FB)    00001320
//FT05F001  DD DDNAME=SYSIN                          00001400
//FT06F001  DD SYSOUT=A                              00001500
//FT07F001  DD SYSOUT=B                              00001600
//SYSGOUMP  DD SYSOUT=A                              00001700
//SYS IN    DD *                                     00001800
```

```
$INT
$ACC A7E-01      46 46 0.0 0.0 0.0 F L U
 1LMIPAN         16 2975 000 594 2975 1475 594 3134 1475 1339
 3259 957       1930 3320 450 2214 3320 000 2300
 2RMIPAN         16 2975 000 594 2975 -1475 594 3134 -1475 1339
 3259 -957      1930 3320 -450 2214 3320 000 2300
 3FWDLHCUN       15 2623 925 289 2623 1875 289 2831 1801 408
 2979 1718      593 2979 928 593
 4LHCUN          14 2609 925 276 -840 925 276 -840 2301 276
 2609 2000      275
 5AFTLHCUN       14 -335 850 276 -853 850 276 -853 2352 276
 -340 2300      275
 6FWRHHCUN       15 2623 -925 289 2623 -1875 289 2831 -1801 408
 2979 -1718     593 2979 -928 593
 7RHCCN          14 2609 -925 276 -840 -925 276 -840 -2353 276
 2609 -2000     275
 8CNSWLFSD       14 2610 925 276 -336 925 276 -336 925 -932
 2610 925      -932
 9CNSWLSRH       14 2610 -925 276 -336 -925 276 -336 -925 -932
 2610 -925     -932
10UWPRLPAN       14 2974 -478 593 2947 -308 463 2947 308 463
 2979 478       593
11LW PFLPAN       14 2947 -308 463 2904 -245 264 2904 245 264
 2949 308       463
12THRTLSD        16 1996 1393 790 1931 1393 765 1882 1393 559
 1969 1388     513 2089 1388 693 2069 1388 763
13THRTLFW D      14 2092 1393 694 1973 1393 518 1973 1141 516
 2089 1138     693
14THRTLRS D      16 1996 1141 790 1931 1141 765 1882 1141 559
 1969 1138     513 2089 1138 693 2069 1138 763
15THRTLAF T      14 1931 1141 765 1882 1141 559 1882 1393 559
 1929 1388     763
16THRTPAF T      14 1996 1141 790 1931 1141 765 1931 1393 765
 1999 1388     793
17THRTLTP C      14 2066 1141 760 1996 1141 790 1996 1393 790
 2069 1388     763
18THRTPFWD       14 2092 1141 694 2066 1141 760 2066 1393 760
 2089 1388     693
19THRLGAFT       14 1905 1216 546 1783 1216 276 1783 1316 276
 1909 1318     543
20THRLGFWD       14 1950 1216 527 1838 1216 27 1838 131 27
 1949 1318     525
21GLSHTP         14 2090 00 2602 5718 00 1776 5718 00 1776
 2090 00       2604
22HJDSCR N       14 2209 374 3226 2209 -374 3226 2901 -374 2447
 2901 374     2447
23CAFLL L        16 1730 1400 1494 1994 1389 2466 2208 1135 2445
 2208 1136     2995 1994 1390 2466 1730 1401 1494
```

24CWFMLL	16	2208	1135	2995	2261	1000	3128	2305	500	3389
2365 501	3389	2261	1001	3128	2208	1130	2995			
25CWFCL	16	2365	500	3389	2384	000	3433	2305	-500	3389
2365 -500	3390	2384	00	3434	2365	500	3390			
26CWFMLL	16	2365	-500	3389	2261	-1000	3128	2208	-1135	2995
2208 -1136	2995	2261	-1001	3128	2365	-501	3389			
27CWFRL	16	2208	-1135	2995	1954	-1389	2406	1730	-1400	1494
1730 -1401	1494	1994	-1390	2466	2208	-1136	2995			
28CWRLL	16	-1158	1782	1494	-1649	1500	2093	-1630	1200	3409
-1830 1201	3409	-1649	1501	2893	-1158	1783	1494			
29CWRMLL	16	-1830	1200	3409	-1942	900	3730	-2014	600	3934
-2014 601	3934	-1942	901	3730	-1830	1201	3409			
30CWRULL	16	-2014	600	3934	-2054	300	4048	-2067	000	4085
-2067 000	4086	-2054	301	4048	-2014	601	3934			
31CWRURL	16	-2067	000	4085	-2054	-300	4048	-2014	-600	3934
-2014 -601	3934	-2054	-301	4048	-2067	000	4086			
32CWRMLL	16	-2014	-600	3934	-1942	-900	3730	-1830	-1200	3409
-1830 -1201	3409	-1942	-901	3730	-2014	-601	3934			
33CWRRL	16	-1830	-1200	3409	-1650	-1500	2893	-1158	-1702	1494
-1158 -1783	1494	-1649	-1501	2893	-1830	-1201	3409			
34CWLBL	14	1730	1400	1494	1730	1405	1494	-1158	1787	1494
-1158 1782	1494									
35CWRBL	14	1730	-1400	1494	1730	-1405	1494	-1158	-1787	1494
-1158 -1782	1494									
36CFTRCL	14	-2067	001	4085	550	001	4072	550	-001	4072
-2067 -001	4085									
37CFMCL	14	550	001	4072	1553	001	3884	1553	-001	3884
550 -001	4072									
38CFTFCL	14	1553	001	3884	2665	001	3347	2665	-001	3347
1553 -001	3884									
39WNOSCRN	14	2665	001	3347	5718	001	1776	5718	-001	1776
2665 -001	3347									
40LRDRPDL	14	3748	1007	85	3748	463	85	3477	463	-653
3477 1007	-653									
41RRDRPDL	14	3748	-1007	85	3748	-463	85	3477	-463	-653
3477 -1007	-653									
42FLRLINE	14	391	925	-945	2131	925	-945	2131	-925	-945
391 -925	-945									
43LHLRSTLN	13	2131	925	-945	4208	925	-1161	4226	925	-945
44RHLRSTLN	13	2131	-925	-945	4208	-925	-1161	4226	-925	-945
45CHLRSTLN	14	4226	925	-945	4208	925	-1161	4208	-925	-1161
4226 -925	-945									
46HUFACE	14	2090	00	2602	2355	00	2139	3223	00	1741
3320 00	2300									
AFTPTLT	0	00	-1108	2600	3125					
AFTPTREA	0	00	-2956	0	2275					
AFTPTRT	0	00	-1108	-2600	-9913					
EMERPOWO	0	00	2589	1675	654					
FCCATG	0	00	2059	1250	600					
FCHKDWN	0	00	2379	-1602	504					
FCHKUP	0	00	2049	-1602	793					
FCLOGGRU	0	00	2609	1043	600					
FCRUPDA	0	00	2784	0	114					
FCSTKRPA	0	00	1647	34	1126					
FCSTKRPM	0	00	2027	34	1151					
FCTFADJ	0	00	1509	975	350					
FCTHRTLA	0	00	1116	1266	704					

FCTHRTLM	0	00	1593	126c	857							
FIADA I	0	00	2449	543	2802							
FIHUU	0	00	2799	0	2779							
FISTBYCO	0	00	3183	-1575	1618							
FWDPTLTD	0	00	4059	3500	2275							
FWDPTRTU	0	00	4059	-3500	3475							
IMPGSSRC	0	00	4869	0	-90							
LONGLT	0	00	611	1542	1284							
MAP CASE	0	00	-890	-1810	624							
MSCANREL	0	00	1111	-1442	904							
NUTRLSRP	0	00	1	0	0							
RUDPOLAB	0	00	2869	725	-456							
RUDPOLAN	0	00	3119	725	-506							
RUDPOLAT	0	00	3369	725	-456							
RUDPOLFB	0	00	3669	725	-506							
RUDPOLFN	0	00	3919	725	-556							
RUDPOLFT	0	00	4209	725	-506							
RUDPORAB	0	00	2869	-725	-456							
RUDPORAN	0	00	3119	-725	-506							
RUDPORAT	0	00	3369	-725	-456							
RUDPORFB	0	00	3669	-725	-506							
RUDPORFN	0	00	3919	-725	-556							
RUDPORFT	0	00	4169	-725	-506							
SNDSEATE	0	00	-6	0	-71							
SRP DCWN	0	00	59	0	-190							
SRP UP	0	00	-90	0	287							
STCPOSLH	0	00	27059	0	-9913							
STCPOSRH	0	00	27059	0	-9913							
STCPOSLF	0	00	27059	0	-9913							
STCPCSRF	0	00	27059	0	-9913							
STOPOSEY	0	00	27059	0	-9913							
WSARMREL	0	00	2908	0	389							
WSBPC	0	00	2259	1350	475							
\$ADD A7—SEAT	5	1	0.0	0.0	0.0	F L U						
001SBTP	14		-435	-750	2359	1	-750	0	1	750	0	
-440	750	2363										
002BKHDRST	14		-495	-350	3535	-350	-650	2655	-350	650	2655	
-495	350	3535										
003SPANMID	14		00	-750	00	00	750	00	1279	750	125	
1279	-750	125										
004SPANFWDL	14		1277	225	131	1277	750	131	1720	750	212	
1719	228	215										
005SPANFWDR	14		1277	-225	131	1277	-750	131	1720	-750	212	
1719	-228	215										
DESEYE	00		0.0	0.0	0.0							
\$END												
/*												
//												

00110000

APPENDIX F

THE JCL AND DATA REQUIRED TO CREATE THE  
COMBIMAN VISIBILITY DATA BASE MEMBER A7E-01

```

//CBMVM      JOB HESS                                00001000
//JOBLIB     DD DSN=COMBIMAN.LOADLIB,DISP=SHR        00001100
//CBMVM      EXEC PGM=CBMVM                          00001200
//FT05F001   CC DDNAME=SYSIN                        00001300
//FT06F001   DD SYSOUT=A                            00001400
//FT07F001   DD SYSOUT=8                            00001500
//FT09F001   DD DSN=COMBIMAN.VISDATA,UNIT=DISK,DISP=(NEW,CATLG),
//           VOL=SER=DISK01,SPACE=(240,2000),       00001600
//           DCB=(BLKSIZE=240,LRECL=240,RECFM=FB)   00001610
//SYSUDUMP   DD SYSOUT=A                            00001700
//SYSIN      DD *                                    00001800
&INT
&ACD A7E-01      2 270.6    0.0 99.15 A R L FS 8L W L
001WINDSCREEN,  FRCNT TOP      32
22763 -584 12535
22379 -551 12324
22098 -546 12157
21893 -519 12059
21579 -467 11876
21314 -427 11735
21109 -362 11616
20914 -281 11584
20914 000 11584
20914 281 11584
21109 362 11616
21314 427 11735
21579 486 11876
21893 519 12059
22098 546 12157
22379 551 12324
22763 584 12535
23000 578 12665
23212 568 12784
23444 541 12903
23731 470 13059
23941 405 13173
24109 292 13286
24212 200 13341
24212 000 13341
24212 -200 13341
24109 -292 13286
23941 -405 13173
23731 -470 13059
23444 -541 12901
23212 -568 12784
23000 -578 12665
002CCKPIT CANOPY CLEARLINE 1 92
29447 000 13550
29404 247 13460
29361 622 13326
29322 832 13201
29261 1054 13024
29209 1243 12860
29162 1378 12700
29114 1503 12557
29067 1589 12415
29002 1730 12238
28959 1805 12086
28907 1886 11944

```

28855	1951	11832	304
28795	1946	11771	304
28743	1946	11732	304
28678	1941	11658	304
28596	1930	11676	305
28471	1930	11659	305
28281	1914	11641	305
28134	1908	11629	305
27987	1897	11616	306
27767	1886	11594	306
27572	1885	11577	306
27335	1849	11555	306
27080	1838	11533	307
26694	1882	11510	
26713	1800	11499	307
26497	1789	11486	307
26073	1751	11442	308
25853	1724	11425	308
25559	1703	11430	308
25469	1697	11460	309
25292	1578	11577	
25192	1470	11745	309
25132	1389	11857	310
25067	1335	11970	310
25067	1335	11970	310
24955	1178	12238	310
24907	1097	12430	311
24873	1010	12550	
24821	881	12700	311
24782	784	12850	311
24743	632	13000	312
24708	497	13200	
24678	281	13450	312
24661	000	13500	312
24678	-281	13450	313
24708	-497	13200	313
24743	-632	13000	313
24782	-784	12350	313
24821	-881	12700	314
24873	-1010	12550	314
24907	-1097	12430	314
24955	-1178	12238	314
25067	-1335	11970	315
25132	-1389	11857	315
25192	-1470	11745	315
25291	-1578	11577	316
25469	-1697	11460	316
25559	-1703	11430	316
25711	-1719	11413	317
25853	-1724	11425	317
26073	-1751	11442	317
26272	-1773	11464	317
26477	-1789	11486	317
26713	-1800	11499	318
26894	-1822	11510	318
27080	-1838	11533	318
27335	-1849	11555	318
27572	-1865	11577	319
27767	-1886	11594	319

27987	-1897	11616	319
28134	-1908	11628	320
28281	-1914	11641	320
28471	-1930	11659	320
28596	-1930	11676	320
28678	-1941	11658	321
28743	-1946	11732	321
28795	-1946	11732	321
28855	-1951	11832	321
28907	-1886	11944	322
28959	-1805	12086	322
29002	-1730	12238	322
29067	-1589	12415	322
29114	-1503	12557	323
29162	-1378	12700	323
29209	-1243	12858	323
29261	-1054	13024	323
29322	- 832	13201	324
29361	- 622	13326	324
29404	- 247	13460	324
29447	000	13550	

&ENC  
/\*  
//

00001900

## REFERENCES

1. Bates, F. J., Evans, S. M., Krause, H. E., and Luming, H., 1974, Three Dimensional Display of the COMBIMAN Man-Model and Workspace, AMRL-TR-74-15 (AD-A027175), Aerospace Medical Research Laboratory, Wright-Patterson Air Force Base, Ohio.
2. Churchill, E. and Kikta, P. E., September 1976, The Aerospace Medical Research Laboratory Anthropometric Data Bank Library, Volumes I-V, AMRL-TR-77-1, Aerospace Medical Research Laboratory, Wright-Patterson Air Force Base, Ohio.
3. Churchill, E., Churchill, T. and Kikta, P., May 1978, Intercorrelations of Anthropometric Measurements: A Source Book for USA Data, AMRL-TR-77-2, Aerospace Medical Research Laboratory, Wright-Patterson Air Force Base, Ohio.
4. Evans, S. M., October 1975, Cockpit Design and Evaluation Using Interactive Graphics, Proceedings of NASA Conference on Applications of Computer Graphics Engineering, NASA-SP-390, NASA Langley Research Center, Hampton, Virginia.
5. McDaniel, J. W., July 1976, Computerized Biomechanical Man-Model, Proceedings of the Sixth Congress of the International Ergonomics Association, University of Maryland, College Park, Maryland.
6. IBM System/360 Operating System Graphic Subroutine Package (GSP) for FORTRAN IV, COBOL, and PL/I, July 1969, Program Number 360S-LM-537, File No. 5360-24, -25, -29 (GC27-6932-3), IBM Corporation, Programming Publications, Dept. 637, Neighborhood Road, Kingston, N.Y. 12401.
7. Zeigen, R. S., et al., December 1960, A Head Circumference Sizing System for Helmet Design: Including Three-Dimensional Presentation of Anthropometric Data, WADD-TR-60-631 (AD 251939), Wright-Patterson Air Force Base, Ohio.
8. Evans, S. M., May 1978, Updated User's Guide for the COMBIMAN Programs, AMRL-TR-78-31, Aerospace Medical Research Laboratory, Wright-Patterson Air Force Base, Ohio.
9. Churchill, Edmund, et al., December 1971. Anthropometry of U.S. Army Aviators - 1970, TR-72-52-CE, United States Army, Massachusetts.

10. Bapu, P., Evans, S., Kikta, P., Korna, M., and McDaniel, J., User's Guide for COMBIMAN Programs Version 4, AFAMRL-TR-80-91, Air Force Aerospace Medical Research Laboratory, Wright-Patterson Air Force Base, Ohio.