

AD-A116 295

TRAINING ANALYSIS AND EVALUATION GROUP (NAVY) ORLANDO FL F/6 9/2
AN OVERVIEW OF THE NAVAL ENLISTED PROFESSIONAL DEVELOPMENT INFO--ETC(U)
MAY 82 T M ANS8RO

UNCLASSIFIED

NL

1 23
ADA
16/150

INFO

END

DATE

FILED

10782

DTIC

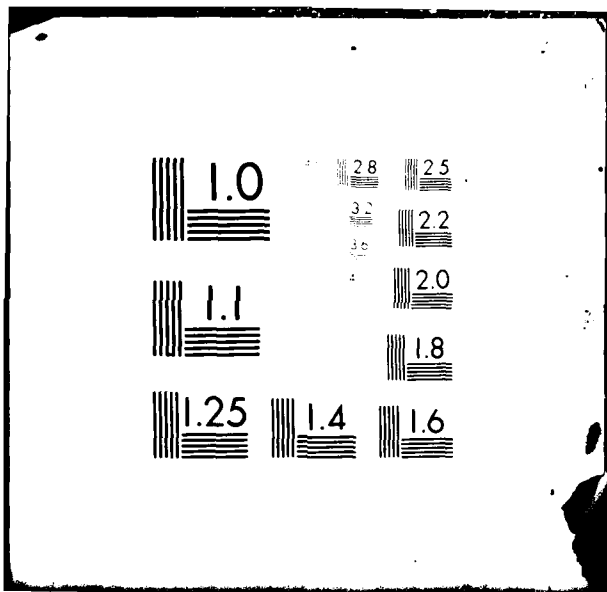

1.0

1.1

1.25

1.4

2.8

3.2

3.6

4

2.5

2.2

2.0

1.8

1.6

AD A1162J5
TAEAG

TRAINING
ANALYSIS
AND
EVALUATION
GROUP

TECHNICAL REPORT 122

122

**AN OVERVIEW OF
THE NAVAL ENLISTED
PROFESSIONAL DEVELOPMENT
INFORMATION SYSTEM (NEPDIS)**

APRIL 1982

FOCUS ON THE TRAINED PERSON



DTIC FILE COPY

82 06 29 019

APPROVED FOR PUBLIC RELEASE;
DISTRIBUTION IS UNLIMITED.

TRAINING ANALYSIS AND EVALUATION GROUP
ORLANDO FLORIDA 32813

12

Technical Report 122

AN OVERVIEW OF THE NAVAL ENLISTED
PROFESSIONAL DEVELOPMENT INFORMATION SYSTEM
(NEPDIS)

Thomas M. Ansbro

Training Analysis and Evaluation Group

May 1982

DTIC
ELECTED
JUN 29 1982
H

GOVERNMENT RIGHTS IN DATA STATEMENT

Reproduction of this publication in whole
or in part is permitted for any purpose
of the United States Government.

Alfred F. Smode

ALFRED F. SMODE, Ph.D., Director
Training Analysis and Evaluation Group

W. L. Maloy

W. L. MALOY, Ed.D.
Deputy Chief of Naval Education and
Training for Educational Development
and Research and Development

Unclassified

SECURITY CLASSIFICATION OF THIS PAGE (When Data Entered)

REPORT DOCUMENTATION PAGE		READ INSTRUCTIONS BEFORE COMPLETING FORM
1. REPORT NUMBER Technical Report 122	2. GOVT ACCESSION NO. AD-A116 295	3. RECIPIENT'S CATALOG NUMBER
4. TITLE (and Subtitle) AN OVERVIEW OF THE NAVAL ENLISTED PROFESSIONAL DEVELOPMENT INFORMATION SYSTEM (NEPDIS)	5. TYPE OF REPORT & PERIOD COVERED	
	6. PERFORMING ORG. REPORT NUMBER	
7. AUTHOR(s) Thomas M. Ansbro	8. CONTRACT OR GRANT NUMBER(s)	
9. PERFORMING ORGANIZATION NAME AND ADDRESS Training Analysis and Evaluation Group Department of the Navy Orlando, FL 32813	10. PROGRAM ELEMENT, PROJECT, TASK AREA & WORK UNIT NUMBERS	
11. CONTROLLING OFFICE NAME AND ADDRESS	12. REPORT DATE May 1982	
	13. NUMBER OF PAGES 29	
14. MONITORING AGENCY NAME & ADDRESS (if different from Controlling Office)	15. SECURITY CLASS. (of this report) Unclassified	
	15a. DECLASSIFICATION/DOWNGRADING SCHEDULE	
16. DISTRIBUTION STATEMENT (of this Report) Approved for public release; distribution is unlimited.		
17. DISTRIBUTION STATEMENT (of the abstract entered in Block 20, if different from Report)		
18. SUPPLEMENTARY NOTES		
19. KEY WORDS (Continue on reverse side if necessary and identify by block number) Naval Enlisted Professional Development Information System Career Planning NEPDIS Occupational Data Base Job Task Analysis Task Descriptions Training Management Front-End Analysis		
20. ABSTRACT (Continue on reverse side if necessary and identify by block number) This is the first in a series of reports designed to describe the origin, development, and applications of the Naval Enlisted Professional Development Information System (NEPDIS). The NEPDIS was designed to be a fully computerized information assembly and analysis system that would eventually support manpower, personnel, and training management. (continued on reverse)		

Unclassified

SECURITY CLASSIFICATION OF THIS PAGE (When Data Entered)

20. ABSTRACT (continued)

This report provides an overview of the NEPDIS, and describes the subsystems. It also summarizes the status of the system and ongoing developments, and presents a model for career planning based on the NEPDIS concept.

As presently configured, the NEPDIS is composed of the following subsystems and files:

- . Training Development Subsystem
 - .. Training Development and Management File
 - .. Task Inventory File
- . Instructional Subsystem
 - .. Instructional Program File
 - .. Training Materials and Literature File
- . Training Record and Evaluation Subsystem
 - .. Training and Education File
 - .. Training Evaluation File
- . Career Development Subsystem
 - .. Career Ladder File
- . Audit Subsystem.

Each of these subsystems and files is described in the report.

Accession For	
NTIS GRA&I	<input checked="" type="checkbox"/>
DTIC TAB	<input type="checkbox"/>
Unannounced	<input type="checkbox"/>
Justification	
By _____	
Distribution/	
Availability Codes	
Dist	Avail and/or Special
A	

FORM 0102-11-014-6601

Unclassified

SECURITY CLASSIFICATION OF THIS PAGE (When Data Entered)



Technical Report 122

TABLE OF CONTENTS

<u>Section</u>		<u>Page</u>
I	INTRODUCTION.....	3
II	SYSTEM OVERVIEW.....	5
	Purpose and Objectives.....	5
	Hardware.....	5
	Overview.....	5
	Training Development Subsystem.....	7
	Task Inventory File.....	7
	Training Development and Management File.....	9
	Instructional Subsystem.....	9
	Instructional Program File.....	9
	Training Materials and Literature File.....	9
	Training Record and Evaluation Subsystem.....	9
	Training and Education File.....	12
	Training Evaluation File.....	12
	Career Development Subsystem.....	12
	Career Ladder File.....	12
	Audit Subsystem.....	15
III	STATUS AND EXTENSION OF NEPDIS.....	17
	Existing Capabilities of NEPDIS.....	17
	Training Development Subsystem.....	17
	Conceptual Overview.....	17
	Processes and Products.....	18
	System Enhancements.....	22
	An Application of the NEPDIS Concept.....	22
	Assignment of Tasks to Pay Grades.....	23
	Derivation of Task-Specific Billet Descriptions.....	23
	Applications of Task-Specific Billet Descriptions.....	23
	Derivation of Rating-Specific Skills.....	25
	Applications of Rating-Specific Skills.....	25

Technical Report 122

TABLE OF CONTENTS (continued)

<u>Section</u>		<u>Page</u>
	Derivation of Rating-Specific Knowledges.....	25
IV	SUMMARY.....	27
	REFERENCES.....	29

LIST OF ILLUSTRATIONS

<u>Figure</u>		<u>Page</u>
1	NEPDIS Subsystems and Data Files.....	6
2	Task Inventory File Printout Mockup.....	8
3	Training Development and Management File Printout Mockup.....	10
4	Instructional Program File Printout Mockup.....	11
5	Training Materials and Literature File Printout Mockup.....	11
6	Training and Education File Printout Mockup.....	13
7	Career Ladder File Printout Mockup.....	14
8	Filled-Out Job Data Worksheet for NEPDIS Data Input (FEA).....	19
9	Filled-Out Task Data Worksheet for NEPDIS Data Input (FEA).....	20
10	Single-Task Printout from Master Job/Task Inventory (JTI) of NEPDIS FEA.....	21
11	Products Derived from Comprehensive Job Task Inventory.....	24

SECTION I

INTRODUCTION

The Chief of Naval Education and Training (CNET) has identified a need for a comprehensive Navy occupational data bank in support of his goal to provide "a proficient occupant for every billet in the fleet" (Cagle, 1973, p. 1). Initially, efforts were directed at identifying and evaluating existing systems having the potential for fulfilling this requirement. A number of occupational data systems which contained portions of the essential information were identified. Among these were occupational data banks supporting Occupational Standards (OCCSTDS), Personnel Qualification Standards (PQS), Engineering Operational Sequencing Systems (EOSS), Advancement-in-Rate Examinations (ARE), and the Naval Occupational Task Analysis Program (NOTAP). The NOTAP supports the OCCSTDS and is also used in advancement examinations and training program development. Despite the fact that such systems exist and meet the purposes for which they were designed, none of them are sufficiently comprehensive to serve all the occupational data needs of the Navy training community. Further, because of noncompatibility of the information contained in these data bases and differing methodologies used in obtaining this information, it was considered unlikely that these systems could be merged to meet CNET requirements. Consequently, CNET initiated the development of a dedicated system to meet the projected needs for occupational data.

In an independent but related action, the Chief of Naval Operations (CNO) established an objective to "integrate all training methodologies and instructional programs through the use of a common data base" (OPNAVINST 5310.13). In the same initiative, the CNO also made clear his intent to use a single occupational data base to support manpower and personnel requirements and to provide appropriate interfaces with training requirements.

The CNET staff recognized that the data base development initiated to meet Naval Education and Training Command (NAVEDTRACOM) needs could be incorporated into a more comprehensive manpower, personnel, and training management information system which would be consistent with the CNO objective. This concept, or system, was named the Naval Enlisted Professional Development Information System (NEPDIS). The NEPDIS concept incorporated job/task/skill analysis and career development systems being developed by CNET (CNET, 1977; Davis, 1977, 1977a, 1977b). At the time, these systems were being independently constructed to support the development and management of both training programs and enlisted careers. The job/task/skill or front-end analysis (FEA) methodology was originally intended to be an improved occupational data acquisition and analysis system for support of Navy Instructional Systems Development (ISD) (CNET, 1978; Davis, 1976). The enlisted career development system, with an integrated training subsystem (from recruitment to retirement), was being experimentally developed to provide the appropriate training at the right time in the career path of each enlisted person so that the effectiveness of the training would be maximized.

While these systems had different purposes, integrating them into a single system furnished an opportunity to construct a Navy occupational data base that could serve the purposes of job analysis, career development, rating

Technical Report 122

and billet description, job qualification, advancement, and personnel assignment.

The present report is the first in a series designed to describe the origin, development, and applications of the NEPDIS. The purpose of this report is to provide a system overview of NEPDIS and a description of the subsystems. It also summarizes the current status of the system, ongoing developments, and a career planning model based on the NEPDIS concept.

A second report will provide a detailed description of the job/task/skill analysis subsystem, describe the role of this subsystem in the NEPDIS, and illustrate an application of this subsystem for selected avionics ratings. A third report will describe a conceptual model for using NEPDIS in career planning including billet descriptions, manpower documents, and training programs.

SECTION II

SYSTEM OVERVIEW

This section presents the purpose and objectives of NEPDIS as originally conceived, describes the overall structure of NEPDIS, outlines the conceptual logic and operation of each of the major subsystems and files, and, finally, discusses the nature of subsystem interactions.

PURPOSE AND OBJECTIVES

The NEPDIS was designed to be a fully computerized information assembly and analysis system to support manpower, personnel, and training management (CNET, 1977). This system includes an occupational data base and a computer-assisted methodology to perform job/task/skill and training analyses.

Specific objectives of the NEPDIS, in accordance with pertinent objectives of OPNAVINST 5310.13, are:

- establish a single, centrally managed, comprehensive occupational data base which will provide for mobility within and among enlisted ratings and Naval Enlisted Classifications (NECs)
- identify common tasks across Navy ratings and NECs
- provide an efficient, integrated, and automated training evaluation methodology
- manage ISD-generated data through automated means
- enable Navy managers to make appropriate decisions in meeting special needs or mission requirements by providing them with a complete record of each enlisted person's training and education experiences
- reallocate tasks among pay grades and establish core and finger courses keyed to specific billet assignments
- establish clearly defined career ladders and career-planning alternatives.

HARDWARE

When operational, NEPDIS is projected to require a computer the size of a UNIVAC 1100/40 or IBM 370 series, with associated peripherals. At present, NEPDIS resides on the Amdahl 1470 computer at the Northeast Regional Data Center, Gainesville, Florida.

OVERVIEW

The NEPDIS is composed of five major subsystems and seven files (figure 1). The Training Development Subsystem contains the Task Inventory File and the Training Development and Management File. This subsystem encompasses job/task/skill data acquisition and analysis and maintains training program development records. The Instructional Subsystem is composed of the

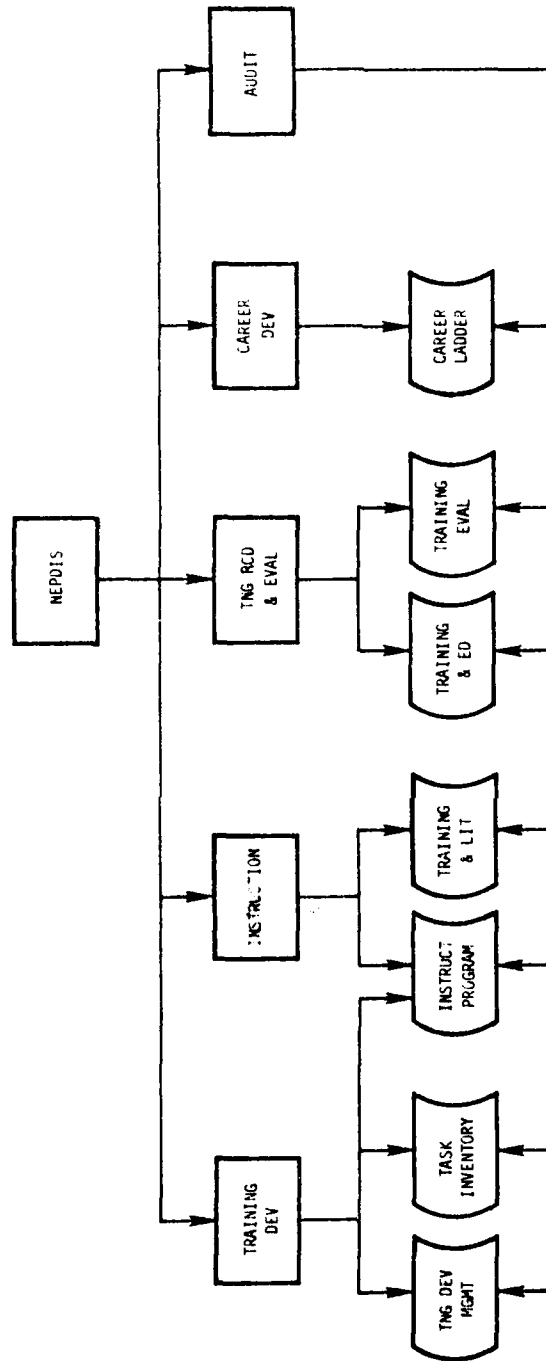

Figure 1. NEPDIS Subsystems and Data Files

Technical Report 122

Instructional Program File and the Training Materials and Literature File. This subsystem will provide a record of all instructional support media and materials and the courses which employ them. The Training Record and Evaluation Subsystem is composed of the Training and Education File and the Training Evaluation File. This subsystem will record individual Navy enlisted personnel biographical and preenlistment data, the results of Navy training, and other training and education. The Career Development Subsystem contains only the Career Ladder File. This subsystem will identify career ladders, locate personnel in a career ladder, and project alternate career paths. Finally, the Audit Subsystem will link the data in the various NEPDIS files and explore the impact of practices, policies, and system changes on training. The following paragraphs provide a more detailed description of each of the subsystems and files.

TRAINING DEVELOPMENT SUBSYSTEM. This subsystem provides a mechanism to acquire, store, classify, and analyze job, task, and skill data. The purpose is to facilitate identification of job/task complexity, establish task interrelationships, determine the degree to which tasks are common, and assign tasks among pay grades as a function of skill level required. The subsystem will identify and classify the skills and knowledges supporting job task performance and provides an audit trail from knowledge elements (information items) through skills to tasks. This subsystem will also maintain a record of training development activities including current status, actions taken, and individual or agency responsibility.

Task Inventory File. This file is operational. It contains all job/task/skill inventories (JTIs) obtained through the NEPDIS FEA methodology for selected ratings. Front-end analysis includes occupational data input from Navy enlisted ratings, NECs, and Navy enlisted occupational groups. Task identification and descriptive data are collected from Navy technical manuals, instructions, specifications, ship and squadron manpower documents, 3-M manuals, PQS, OCCSTDS, NOTAP, equipment manufacturer's texts, and instructional materials. These materials are augmented by technical guidance from Navy subject matter experts (SMEs) assigned to NEPDIS data collection. Figure 2 outlines the contents of the Task Inventory File. Job, task, and skill information entered into the file is analyzed by the computer and structured to provide such task descriptors as:

- task complexity--an inherent quality of the task derived from the number and character of the skills and other work behaviors required to perform the task
- task commonality--a comparison among tasks of the work behaviors and skills underlying task performance. For use in NEPDIS, tasks are considered common only when all the work behaviors and associated descriptors underlying them are found to be identical.
- task componency--describes the hierarchical relationships among tasks in an inventory. With regard to componency, there are four kinds of tasks:

Technical Report 122

- identical tasks are 100 percent common with other tasks
- omnibus tasks contain other tasks
- embodied tasks are tasks included in other tasks
- unique tasks are not common with any others in the set of tasks being examined; they neither embody nor are embodied in other tasks (Davis and Perry, 1980).

Outputs of this file are the Task Commonality Report and the Task Information Report (full information on a particular task).

Training Development and Management File. The prototype software supporting this file has been developed. When completed, the file will maintain a record of all training development activities including development of curricula, training literature, and instructional media. The user will be able to generate a Training Program Development Current Status Report of these activities for a course. Full implementation of this file depends on the future development of procedures to obtain information on the data elements contained in the file. The file content is shown in figure 3.

This file uses information from the Training Materials and Literature File and the Instructional Program File of the Instructional Subsystem. Decisions made in training program development and the current status of any given training development activity can be extracted from this file.

INSTRUCTIONAL SUBSYSTEM. This subsystem, when developed, will provide listings of instructional programs and support items which exist or are under development. The Instructional Program File and the Training Materials and Literature File record instructional support media and materials and identify the instructional programs using these materials. Information from this subsystem along with information obtained from other files will allow an audit trail from learning objectives through performance measures to tests. Training course synopses, course entry requirements, and other course prerequisites are also contained in this subsystem. This subsystem will include resident, nonresident, and on-the-job (OJT) training programs.

Instructional Program File. Each Instructional Program File record contains a course synopsis. Computer programs are available to translate task performance data in the master JTI to fully detailed learning objective statements in each record. Statements of objectives can then be arranged to obtain curriculum outlines. Linkages among support items in training programs can be established and verified. The file content in the current version is shown in figure 4. Software for file content is still under development, although some portions exist.

Training Materials and Literature File. This file will record all training literature and instructional media associated with an instructional program, regardless of development status. An audit trail will link training literature and media to learning objectives, performance measures, and, ultimately, tasks. File content is shown in figure 5. This file can be

```

NEEDS
TRAINING DEVELOPMENT MANAGEMENT FILE
INSTR PROG NO.   INSTR -PROG TITLE   DATA SETTINGS
COI AE A C-602-2222 AE CLASS H COI   RESIDENT SCHOOL CLASS H

TASK REFERENCE NOS.   JOB PERFORMANCE MEASURE NOS.
AE 0016 0103          AEAS614 (AE 0016 0103)
AE 0016 0114          AEAS626 (AE 0016 0114)
:
:
L/O NOS.             L/O CLASS   CRITERION REF MEASURE NOS.
AEAS600              TO          5600-1-10
AEAS601              EO          5600-1-00
:
:
TEST STATUS
ITEM BANK DEPTH: 500%.  FCOME 750JFM;  PYP(MS) 300;  JFM 600

PROG IMPLEMENT DATE   ORGANIZATION AND INDIVIDUAL RESPONSIBLE FOR ACTIVITY
760926               NATTC MEMPHIS (AE CLASS H SCH)   CO NATTC MEMPHIS

LOCATION(S) OF TRAINING   PROGRAM DEVELOPMENT COSTS
NATTC MEMPHIS          $2245 PER HR OF INSTRUCTION (ESTIMATED)

TRAINING LIT & MATLS FIG NOS.   ALTERNATIVES
AEA C-602-2222-24A             ATA D-200-24-14-11A
AEA C-602-2222-11B            ATA C-200-24-14-05B

CURRENT STATUS OF PROGRAM
PRESENT COI BASED IN PART ON TRAINING APPRAISAL OF PREVIOUSLY EXISTING COI AND
SKILLS PROFILE PLUS NOTEP SURVEY OF 7500005.  NOTEP RE-SURVEY SCHEDULED FOR 1981.
TRAINING APPRAISALS AND SKILLS PROFILES TO BE UPDATED TO WORKERS WITH RECENTLY
AND TIS.  NEEDS OCCUPATIONAL DATA BANK (OJ) FOR AE RATING INITIATED 1977-78.
FEA COMPLETE, UPDATED TO 1981.  TRAINING OPERATIONS FIRM TO BE OPEN BY 1980.
OUTPUTS EXPERIMENTALLY DEVELOPED 8-1-81.
    
```

Figure 3. Training Development and Management File Printout Mockup

Technical Report 122

```
REF ID IS          INSTRUCTION
INSTRUCTIONAL PROGRAM FILE      DATE: XXXXXX
INSTR PROG NO.      INSTR PROG TITLE      INSTR SETTING
TRAINING LIT & MATRL NOS. (PAGES & UNITS)
L7D NOS.
CRITERION REF MEASURE NOS.
ENTRY REQMTS (BASIC APT/CAF)
CUI SYNOPSIS
```

Figure 4. Instructional Program File Printout Mockup

```
REF ID IS          INSTRUCTION
TRAINING LITERATURE & MATERIALS FILE      DATE: XXXXXX
INSTR PROG NO.
TRAINING LIT & MATRL NOS.  TNG LIT & MATRL TITLES  TYPE  SOURCE
L7D NOS.
USER COMMENTS
```

Figure 5. Training Materials and Literature File Printout Mockup

the Required Literature and Material Report for a specific course, or a Required Training Report for a specific task.

TRAINING RECORD AND EVALUATION SUBSYSTEM. This subsystem will record biographical and preenlistment educational data for each individual and the results of Navy and other subsequent training and education for all enlisted personnel. Educational experiences will be related to specific tasks and skills required by billet assignments; thus, this subsystem can be used to determine the equivalency of the training furnished to different Navy ratings. Also, this subsystem will track an individual student in terms of specific educational and training experiences and will contain data to enable the evaluation of courses. The Training and Education File and the Training Evaluation File are contained in this subsystem.

Training and Education File. This file will provide a central comprehensive education and training record for all Navy enlisted personnel. Contents of the file are shown in figure 6. A segment of each individual's training record will be reserved for temporary training evaluation data. Once a specific evaluation has been completed, the analysis will be deleted from the file; the file segment may then be used again in future evaluations. The extent to which training has met objectives can be determined by establishing relationships among skills required on the job, tasks and skills trained in Navy schoolhouses, skills associated with prior work experience, and other formal training. The principal product of this file will be the Advancement Examination Equivalencies Report.

Training Evaluation File. This file will be designed to summarize training evaluation data from the Training and Education File for the purpose of training program assessment. Computer routines are not currently developed. These files will constitute a depository of information extracted from, and cross-listed with, other subsystem files. The focus of this file is on training program, not student assessment.

CAREER DEVELOPMENT SUBSYSTEM. When developed, this subsystem will provide a means for identifying enlisted career ladders, an individual's position within a given career ladder, and career options open to individuals. This subsystem will assist in identifying the most cost-effective career paths for enlisted personnel. Data from other NEPDIS subsystems will be used to establish career paths as well as equivalency of training. An additional aim of this subsystem is to provide the potential for career satisfaction through projection of a career path which ensures advancement and equitable transfer of occupational specialty. Information from this subsystem could be used to evaluate training program consolidations and to assess the impact of new technology. Also, shortfalls in training requirements could be identified from information in this subsystem, leading to interim training programs. The intention is to improve job satisfaction and retention and to enhance billet assignments.

Career Ladder File. As presently envisaged, this file will record all enlisted career ladders and will identify (1) the pay grades associated with each career ladder step, (2) the core and finger course training required to achieve each grade, (3) where training may be acquired, and (4) when training is required during any given career continuum. Figure 7 lists the

NEPDIS TRAINING RECORD AND EVALUATION

TRAINING AND EDUCATION FILE DATE: 810721

NAME/RATING/RATE SSN DATE/PLACE OF BIRTH/ENLISTMENT
 DOE. JOHN H. AEE XXX-XX-XXXX 610223/NY NY 790717/NY NY

PRE-NAVY EDUCATION/TRAINING MAJOR(S) DIPLOMA GRADE AVG
 HIGH SCHOOL DATE COMPL COMMERCIAL NYCBE/REGENTS 3.2
 ABR LINC HS BKLN NY 790611

VOCATIONAL TNG DATE COMPL OCCUPATION CERTIFICATE GRADE AVG
 COLLEGE DATE COMPL MAJOR(S) DEGREE/CERT GRADE AVG

13

NAVY EDUCATION/TRAINING

INSTR PROG NOS. LENGTH OF COI DATE COMPL GRADE AVG
 X-777-7770 56 DAYS XXXXX X.XX
 X-777-7771 28 DAYS XXXXX X.XX
 A-100-00-10 33 DAYS XXXXX X.XX
 C-602-2222 55 DAYS XXXXX X.XX

RATING ENTERED ASSIGNMENT DATE CAREER LADDER NO. PREVIOUS CAREER LADDER NOS.
 AE YXXXXX EL/ELEC 024-41

EQUIVALENCY EXAM NOS. DATES TAKEN SCORES JPMS COMPL CROSS-TNG INDIC/COMPL

AT-C-200-2001 XXXXXX X.XX 5925-2-23 NO
 : : 5944-5-11
 : :

Figure 6. Training and Education File Printout Mockup

NEPDIS CAREER DEVELOPMENT

CAREER LADDER FILE DATE: 790924

CAREER LADDER NO: EL/ELEC 024-41

REQUISITE EXPERIENCE: NAVY INSTR PROG NOS/FOJT/PRE-NAVY VOC ED INSTR PROG NOS: BASIC MILITARY PLUS A-100-00-10; C-602-2222; ETC (APPLICABLE RESIDENT SCHOOL COURSES, FORMAL OJT PROGRAMS, FRAMPS, NEC TRAINING, RATING-ENHANCING/NON-RESIDENT COURSES, OBT PROGRAMS)

REQUISITE SKILLS: SOLDERING, OXY-ACETYLENE BRAZING, USING MICROMINIATURE ELECTRONICS REPAIR TECHNIQUES, USING GENERAL PURPOSE TEST EQUIPMENT, USING SPECIAL PURPOSE TEST EQUIPMENT, USING HAND TOOL SUITE COMMON TO ELECTRICITY/ELECTRONICS MAINTENANCE, READING/INTERPRETING SCHEMATIC DIAGRAMS/ELECTRONICS SYMBOLS/COMPUTER LOGIC CIRCUITRY (ALL THE ABOVE MAY BE CODE-IDENTIFIED, CROSS-CODED INTO COMPONENT-BEHAVIOR APPRAISALS AUDITABLE TO THE TASK INVENTORY FILE, SEPARATED INTO SKILL/KNOWLEDGE ITEM HIERARCHIES, ETC.)

PHYSICAL REQUIREMENTS: ENLISTMENT REQUIREMENTS

EQUIVALENCIES: JFMS, ADVANCEMENT EXAMS, PDS, AND OCSIDS LISTED AS FOLLOWS:ALSO LISTED IN ASSOCIATED AND ALTERNATE CAREER LADDERS

ALTERNATE CAREER LADDER PATH (NOS.):
RECOMMENDED EQUIVALENCY EXAMS, CROSS-TRAINING PACKAGES:

Figure 7. Career Ladder File Printout Mockup

Technical Report 122

contents of this file as projected at this time. Such a career ladder layout may aid in assessing the potential effect of introducing new technologies, or radical changes to current ones, upon occupational fields. The Career Ladder File includes a consideration of alternate career choices. From it, it will be possible to generate a Career Ladder Alternatives Report.

AUDIT SUBSYSTEM. This subsystem will assess the impact of hardware modifications, operating practice, policy, and doctrine on training. Also, it will provide an overview of the cumulative effect of these impacts on a variety of training system components from job task inventories to instructional programs. Hence, this subsystem will have a capability to alert training activities when they will be impacted by changes in the manpower requirements or in systems hardware. Development of this subsystem has not yet begun.

SECTION III

STATUS AND EXTENSION OF NEPDIS

This section provides a brief summary of the present capabilities of NEPDIS, describes ongoing development activities designed to enhance or expand present capabilities, and describes the systematic application of NEPDIS concepts to a selected enlisted rating group.

EXISTING CAPABILITIES OF NEPDIS

TRAINING DEVELOPMENT SUBSYSTEM. Up to the present, NEPDIS development has been focused on modifying and refining front-end job/task/skill data acquisition, storage, and analysis methodology--the principal product of which (in NEPDIS) is the Task Inventory File. The interdependency of the NEPDIS subsystems and files has made the conceptual development of other NEPDIS structures contingent on the development of the Task Inventory File. In general, the front-end data acquisition, storage, and analysis mechanisms for this subsystem are now in place (Ansbrosio, 1978). The various subroutines have been developed and tested and are ready for use in a curriculum development project. Such a practical exercise will undoubtedly reveal the need for some changes to make the subsystem fully functional.

CONCEPTUAL OVERVIEW. The NEPDIS, as it currently exists, uses Navy job/task/skill data in occupational fields (ratings, NECs, job communities) to support or provide computerized task inventories for eventual use in assembling billet descriptions, ship and squadron manpower documents, training course curricula, job/task performance elements, or enlisted career qualification, certification, and advancement criteria. A principal doctrine of NEPDIS is that occupational data acquisition, storage, and analysis are prerequisite to full-scale training system development. The occupational data, accompanied by extensive identification and descriptive data, are introduced into the system once. All outputs determined to be necessary for expressed manpower, personnel, and training needs are derived from this data input via the computer subroutines. The NEPDIS requires a wide range and variety of accurate task and skill (work behavior) data to accomplish its objectives. Consequently, the NEPDIS data acquisition and analysis functions are focused on what documented tasks should be done on the job rather than on frequency counts of what is being done by job incumbents. Hence, there is a need to explore information sources other than job incumbents' responses to questionnaires or interviews which heretofore has been the primary source of job task information.

Basic to the NEPDIS FEA approach is the proposition that FEA is entirely workplace oriented. Therefore, occupational data acquisition and analyses are restricted to computations and determinations of task and skill relationships within occupational field hierarchies. No training information is included in NEPDIS FEA. Information or decisions regarding training importance of tasks, skills, or elements of job knowledge or priority estimates of task/skill/knowledge sequences for training course development are considered part of data-handling phases in ISD methodology. Analysis of such data may be termed training task analysis, which is not part of the FEA process.

Technical Report 122

During design of the Training Development Subsystem, it was determined that the data structure of the JTI should generally reflect the content and format of the subsystem file. The most important difference between the JTI and the Task Inventory File was that all the data in the JTI were entered in raw form for subsequent analysis. Identification data (references, tools, test equipment, etc.) and task descriptive data (general characteristics, duty subcategory, skills) were extracted primarily from reference materials and experience. Subsequently, the computer established such hierarchical relationships as task complexity, inter-task commonality, componency, skill level and/or pay grade performing (Davis and Perry, 1980). These products of later analysis appear in the Task Inventory File. This file also provides a means of tracking processed data in other follow-on files to a reference or to any other basic inventory item.

PROCESSES AND PRODUCTS. In NEPDIS FEA, SMEs acquire occupational data, amplified by official Navy technical and training literature, instructions, specifications, and other authoritative work descriptions and manning documents. The initial product of this activity is a Master JTI, a comprehensive list of tasks for platforms, weapons systems, occupational fields, or the provision of particular services.

A JTI coverage can be set at an entire Navy rating, an NEC, specific watchstanding task groupings, military specialties, a Navy occupational field, maintenance or operation of a family of equipment items, or of a specific system. In NEPDIS FEA for avionics ratings, resulting JTIs have run to thousands of tasks. During the NEPDIS FEA runs, tasks are entered on two task data input forms: (1) the Job Data Worksheet (JDW) used for recording task identification data (figure 8) and (2) the Task Data Worksheet (TDW) used for recording descriptive data for entry into the computer (figure 9). Figure 10 shows a representative page of data from the Master JTI.

Once data are entered on the forms, the JDW/TDW data are keypunched and entered in the computer for analysis. In essence, once a complete list of required outputs has been determined, the system functions on demand so that:

1. Task commonality (inter/intra-rating/NEC/occupational field/system) may be identified; output inventories can be purged of duplicate tasks.
2. Hierarchies of tasks can be established. Tasks may be partitioned into skill level or pay-grade arrays, within equipment system hierarchies.
3. Task lists may be translated into lists of learning objectives, prioritized by complexity, componency, or any other task/skill hierarchies required by the eventual user of the outputs.
4. Matrices of billet-specific tasks or rating-specific skills can be printed.

Technical Report 122

TASK DATA WORKSHEET

RATING HTC

PACKAGE 01

TASK #	GENERAL SUBCATEGORY	DUTY SUBCATEGORY	SKILL AREA 1	SKILL AREA 2	SKILL AREA 3	SKILL AREA 4	SKILL AREA 5
1	(a) b c	1 (a) b c	1 a b (c)	1 (a) b c	1 a (b) c	1 a b c	1 a b c
2	(a) b c	2 (a) b c	2 (a) b c	2 a (b) c		2 a b c	2 a b c
3	(a) b c	3 a (b) c	3 (a) b c	3 a (b) c		3 a b c	3 a b c
4	(a) b c	4 a b (c)	4 (a) b c	4 a (b) c		4 a b c	4 a b c
5	a (b) c	5 a (b) c	5 (a) b c			5 a b c	5 a b c
6	a (b) c	6 a b c				6 a b c	6 a b c
7	(a) b c	7 a (b) c				7 a b c	7 a b c
8	a (b) c	8 a (b) c				8 a b c	8 a b c
9	a b (c)	9 a b c				9 a b c	9 a b c
10	(a) b c	10 a b c				10 a b c	10 a b c
11	a b c	11 a b c				11 a b c	
		12 a b c					
		13 a b c					
		14 a b c					
		15 a b c					

TASK #	GENERAL SUBCATEGORY	DUTY SUBCATEGORY	SKILL AREA 1	SKILL AREA 2	SKILL AREA 3	SKILL AREA 4	SKILL AREA 5
1	(a) b c	1 (a) b c	1 a b (c)	1 (a) b c	1 a b (c)	1 a b c	1 a b c
2	(a) b c	2 (a) b c	2 (a) b c	2 a b (c)		2 a b c	2 a b c
3	(a) b c	3 a (b) c	3 (a) b c	3 (a) b c		3 a b c	3 a b c
4	(a) b c	4 a b (c)	4 (a) b c	4 a (b) c		4 a b c	4 a b c
5	a (b) c	5 a (b) c	5 (a) b c			5 a b c	5 a b c
6	a (b) c	6 a b c				6 a b c	6 a b c
7	(a) b c	7 a (b) c				7 a b c	7 a b c
8	a (b) c	8 a (b) c				8 a b c	8 a b c
9	a b (c)	9 a b c				9 a b c	9 a b c
10	(a) b c	10 a b c				10 a b c	10 a b c
11	a b c	11 a b c				11 a b c	
		12 a b c					
		13 a b c					
		14 a b c					
		15 a b c					

Figure 9. Filled-Out Task Data Worksheet for NEPDIS Data Input (FEA)

Technical Report 122

```

ND.*** 154          RATING: AE          FFB: 0002          TASK: 0014          DS: 1          AE-0002-0034
PLATFORM : P-3 A/B/C          SYSTEM : F56 ENGINE
EQUIPMENT : THRUSTLE/FWR LVR          COMPONENT : FWR LVR WRN HORN ACTR & SW          COMPONENT
MODULE : NOT LODED
ACTION : REP.. REPAIR FWR LVR WARNING HORN & SW ASSY 29319          CUE.....REPAIR COMPLETE
CUE.....MALFUNCTION
STANDARD.....TAW REFERENCE PUBLICATIONS          REFERENCE.....NA 01-75-FAA-2-4
TOOL.....COMMON HAND TOOLS          SUPPORT MATR...CLN SOLV P-D-680
SUPPORT MATR...CROCUS CLOTH          SUPPORT MATR...LURDIL VV-L-800
SUPPORT EQUIP..COMPRESSED AIR/NITROGEN          TEST EQUIP.....MULTIMETER AN/FSM-4

GENERAL.....2113111200000000000000
DUTY SUB 02.....0200001200000000000000
SKILL 1.....2111300000000000000000
SKILL 2.....1211000000000000000000
SKILL 3.....2000000000000000000000
SKILL 4.....1110011000000000000000
SKILL 5.....2233211130000000000000

COMPLEXITY : 1.25
    
```

Figure 10. Single-Task Printout from Master Job/Task Inventory (JTI) of NEPDIS FEA

Technical Report 122

5. Given development of appropriate software, NEPDIS and other information systems (3-M, for instance) can "crosstalk"; this enhances data verification and enables the NEPDIS data bank to be updated to incorporate changes.

FEA provides the Master JTI and all the data required for outputs that eventually appear in the Training Development Subsystem Task Inventory File. The variety and scope of analysis outputs, the capability of adding inputs to the file via the JTI, and the presence of an audit trail, document the importance of this file to all the subsequent files in all the other subsystems of NEPDIS. This one file enables the user to track training behaviors, job performance measures, and component skills; to identify the origin of training literature and materials; and to match job-incumbent competency with billet/task/rating requirements.

SYSTEM ENHANCEMENTS

While NEPDIS, as described in this report, will contain subsystems and files that deal with manpower management and personnel administration, the system is more elaborately designed to support training. When the concept for the system was framed, training development, management, and evaluation needs were more obvious to the system designers than were those associated with manpower and personnel. As a result, three of the five subsystems support training. Only the Career Development Subsystem embraces manpower management and personnel directly. As the FEA evolved, and CNO objectives were enunciated in OPNAVINST 5310.13, the potential for extension into manpower and personnel activities became more obvious. Current FEA development activities have made it possible to generate computer-composed billet descriptions and to identify rating-specific skills.

Development efforts in FEA have also called attention to the possible need for modifying the NEPDIS structure. For example, the presence of the audit capability in FEA tends to reduce the need for the projected Audit Subsystem as a separate subsystem. Since audit functions are usually an integral part of most evaluation procedures, a projected consolidation of the Training Record and Evaluation Subsystem and the Audit Subsystem is being considered.

Currently, experimentation with direct input (via microcomputer) of task information is being carried out with the Storekeeper (SK) rating. If successful, this interactive process will eliminate the pencil and paper task of data recording and keypunch operation used in earlier FEA.

AN APPLICATION OF THE NEPDIS CONCEPT

In order to demonstrate the various means by which a comprehensive job/task/skill inventory could be employed by the Navy's manpower, training, and personnel establishment, an effort was undertaken to develop a model for use of NEPDIS data base concepts within one enlisted rating. The intent of this effort was to show how to produce task-specific billet descriptions, to identify rating-specific skills, to identify rating-specific knowledges, and to demonstrate the use of the above products in support of the perceived needs of manpower, training, and personnel managers.

Technical Report 12?

The effort was restricted to the Aviation Electrician's Mate (AE) rating because the NEPDIS front-end analysis data for the rating were already available and the products of this effort were anticipated to be of use in the next scheduled revision of the AE "A" school course. In the following paragraphs (illustrated by figure 11) a brief description is provided on (1) producing task-specific billet descriptions, (2) identifying rating-specific skills, and (3) a conceptual approach to the identification of rating-specific knowledges. A detailed discussion of each of the steps in this process will be the subject of a future technical report.

ASSIGNMENT OF TASKS TO PAY GRADES. The total inventory of tasks was statistically divided into pay-grade groups by first plotting the complexity index of each task on a frequency histogram and then applying conventional statistical analysis procedures to divide the inventory into four parts. Tasks in each of the four parts were assigned to skill-level groups called "trainee," "apprentice," "journeyman," and "advanced journeyman." The apprentice and the journeyman skill-level groups were further divided to produce six pay-grade groups from E-2 through E-7. The inventory of tasks for each pay grade served as an input into algorithms for producing subsequent products.

DERIVATION OF TASK-SPECIFIC BILLET DESCRIPTIONS. If billets could be precisely written using specific tasks to define the work requirement, then managers would be able to develop training, assign personnel, and determine manpower requirements with greatly increased accuracy. Further, an audit trail to evaluate the decisions and products would now be possible, and changes could be initiated if required. Task-specific billet descriptions were derived from the total inventory by identifying those tasks assigned to a single pay grade for a specific platform (aircraft type) at a specific work site. Once the tasks had been divided into pay-grade groups during initial processing, the computer merely sorted tasks by platform and work site to produce the billet descriptions. Two sample billets were written: (1) organization-level maintenance on the P-3 aircraft for pay grade E-4 and (2) intermediate-level maintenance on the P-3 aircraft for pay grade E-4.

Applications of Task-Specific Billet Descriptions. An important consideration for training managers has been to determine which tasks should be trained and where the training should take place. Using the descriptive characteristics as they were recorded for each task, commonality and componency studies were run, and tasks were prioritized for training and assigned to appropriate training settings. Tasks with a high degree of commonality and componency were given high priority, while unique tasks and tasks embodied within other tasks were given low priority for training. Training for high priority tasks was assigned to schoolhouse settings, while that for low priority tasks was assigned to OJT settings.

Task-specific billet descriptions further served as criteria for advancement-in-rate and for certification in specific billets. It seemed reasonable to assume that as a worker advanced in skill level, he/she should be able to perform work of higher complexity, and should expect to receive compensation in relation to that work. The algorithm supporting that theory used tasks, skills, and knowledges as elements. An existing subsystem, PQS, served as the mechanism for certifying both tasks and skills, while the ARE served as the mechanism for certifying knowledge requirements.

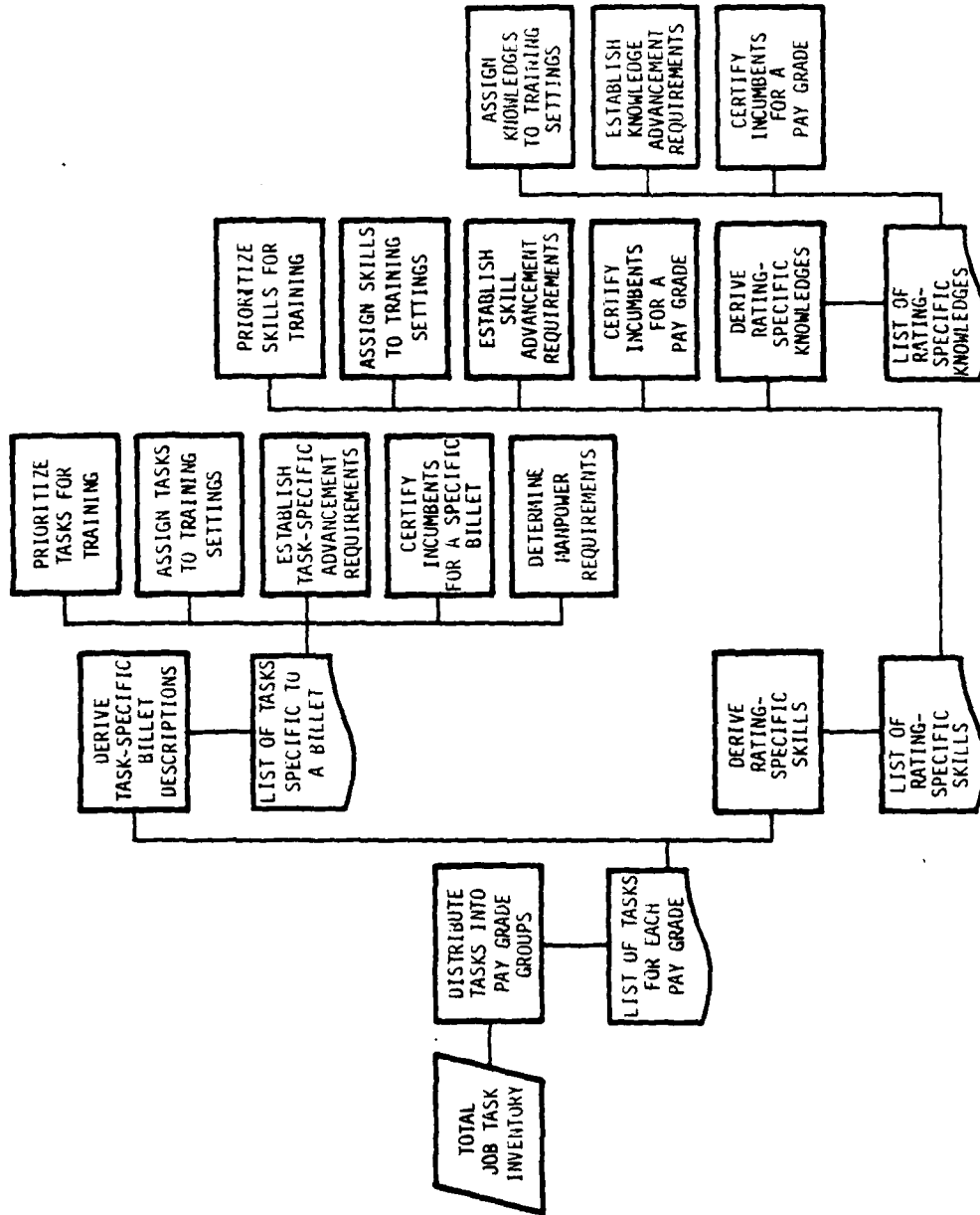

Figure 11. Products Derived from Comprehensive Job Task Inventory

An important part of the NEPDIS data base was the use of 3-M's work unit codes to identify all task objects, making it possible to match NEPDIS data with that of 3-M. By matching data it was possible to determine man-hour requirements for a billet. It was likewise possible to determine man-power requirements.

DERIVATION OF RATING-SPECIFIC SKILLS. Rating-specific skills were identified as those skills that the workers in a rating needed in order to perform tasks competently at a particular pay grade. Since the NEPDIS task data included all references, tools, support material, support equipment, and test equipment required to support each task, much information on the skill requirements was readily available for computer analysis. From the inventory of tasks for each pay grade, every support item (reference, tool, etc.) was identified, and a count was made to determine the number of platforms and systems which required that item for support. The count was used to rank-order the items from the most practical because of wide usage to the least practical because of esoteric usage.

Items which were required to support more than one platform or system were identified as rating-specific "skill objects." The skill, derived from the "skill object," became "the ability to use that particular object as it was intended in support of tasks."

Applications of Rating-Specific Skills. Like tasks, skills also require training and, consequently, some method for prioritizing training. The scheme used was to assign a high priority to those skills with the widest application and a low priority to those with narrow application. The count of platforms and systems requiring a particular skill was the criterion for determining the scope of application.

Training settings were selected by applying the priority scheme previously described. High-priority skills were assigned to schoolhouse settings with a back-up in correspondence courses and rate training manuals; low-priority tasks were assigned to onboard training packages, rate training manuals, and specialized "C" schools.

The applicability of skills as criteria for advancement and certification was treated much like task-specific billet descriptions. While tasks served as criteria for advancement and certification in a billet, skills served as criteria for advancement and certification within a rating. The PQS would be used as the mechanism for evaluation.

DERIVATION OF RATING-SPECIFIC KNOWLEDGES. One additional analysis is required to derive job knowledge requirements from skills identified in the JTI (Ansbro and Hayes, 1981). The specific details have not been established but will almost certainly include information taken from the descriptive characteristics. Once the knowledge requirements have been identified, they will also be assigned a priority for training and introduced as elements for advancement and certification in a rating and a billet. The ARE will serve as the mechanism for evaluation.

SECTION IV

SUMMARY

This report provides an overview of the NEPDIS. It describes NEPDIS subsystems, summarizes the current status of the system and ongoing developments, and treats a projected application of the NEPDIS concept to a model for Navy enlisted career planning.

The NEPDIS development evolved from a perceived need for a comprehensive Navy occupational data base that could support a CNET goal to provide "a proficient occupant for every billet in the fleet" (Cagle, 1973, p. 1). This concept was also perceived to be consistent with the CNO objective to "integrate all training methodologies and instructional programs through the use of a single data base." Efforts to identify existing systems which would meet these objectives revealed that their data bases, if included, were not sufficiently comprehensive to serve all perceived occupational data needs of the Navy training community.

The NEPDIS was designed to be a fully computerized information assembly and analysis system that would eventually support manpower, personnel, and training management. The system includes an occupational data base and a computer-assisted methodology to perform the front-end job/task/skill analysis. As presently configured, the NEPDIS is composed of five major subsystems which include seven files. The Training Development Subsystem contains the Training Development and Management File and the Task Inventory File. This subsystem encompasses job/task/skill data acquisition and analysis and maintenance of training program development records. The Instructional Subsystem, through its Instructional Program File and Training Materials and Literature File, is designed to provide a record of all instructional support media and materials and the courses which employ them. The Training Record and Evaluation Subsystem, composed of the Training and Education File and the Training Evaluation File, is intended to record individual Navy enlisted personnel biographical and preenlistment data, the results of Navy training, and other training and education data. The Career Development Subsystem, containing the Career Ladder File, is projected to provide a means for identifying career ladders, locating personnel within career ladders, and projecting alternate career paths. The Audit Subsystem is designed to provide a means of linking data in and among various NEPDIS files and to explore the impact of practices, policies, and system changes on training. It is the final subsystem in NEPDIS.

Of these subsystems and files only the Task Inventory File of the Training Development Subsystem is fully operational. The remaining subsystems are at various stages of conceptual or computer software development. However, it should be recognized that the Task Inventory File contains extensive information and capabilities, the development of which was necessarily prerequisite to the development of all the other subsystems and their files. This file is currently capable of accepting and analyzing all job/task/skill inventory information obtained through NEPDIS FEA methodology. This information can be analyzed and structured to provide such task descriptors and interrelationship designators as task complexity, commonality, and componency. This

Technical Report 122

file is developed from extensive Master Job Task Inventories from which a variety of manpower, personnel, or training documentation can be derived.

A trial application of FEA outputs of NEPDIS has demonstrated the capability of producing examples of some of these manning documents through use of task-based billet descriptions, distribution of tasks into skill level/pay groups, and identification of rating-specific skills. Such information can support job certification and advancement, career development, and assignment of training settings.

At present, direct input of task information via microcomputer is under development as a means of enhancing system performance. Consideration is also being given to modifying the NEPDIS structure to eliminate redundancies in subsystems and files, to exploring the possibility of combining some features of the subsystems, and to providing additional support for manpower and personnel activities.

Technical Report 122

REFERENCES

- Ansbro, T. M. "Using the computer to build the task inventory." Proceedings of the 20th Annual Conference of the Military Testing Association. 1978. Oklahoma City, OK, pp. 263-274.
- Ansbro, T. M. and Hayes, W. A. "The job task analyses/skills and knowledge marriage (parts I and II)." Proceedings of the 23rd Annual Conference of the Military Testing Association. Volume I. October 1981. Washington, DC.
- Cagle, M. W. "Dimensions." TraNavy: Magazine of Naval Training, 1973, p. 1.
- Chief of Naval Education and Training (CNET). NEPDIS automated data systems implementation plan. 1977. Pensacola, FL.
- Chief of Naval Education and Training (CNET). Procedures for instructional systems development. NAVEDTRA 110. 12 July 1978. Pensacola, FL.
- Chief of Naval Operations (OP-01D). OPNAVINST 5310.13, subj: Manpower, training and personnel plan. 28 January 1978. Washington, DC.
- Davis, D. D. "Dialogue." CAMPUS: The Navy Education and Training Monthly. January 1976. pp. 22-27.
- Davis, D. D. "Dialogue." CAMPUS: The Navy Education and Training Monthly. April 1977, pp. 22-27.
- Davis, D. D. "Naval enlisted professional development information support system." Proceedings of the National Security Industrial Association of the State-of-the-Art Application of Advanced Training Technology. April 1977a.
- Davis, D. D. "Naval enlisted professional development information support system." Journal of Educational Technology Systems, 6 (2), 1977b. pp. 133-141.
- Davis, D. D. and Perry, Nancy N. "Determining task commonality in Navy training: two methods examined." Proceedings of the 22nd Annual Conference of the Military Testing Association, Volume I. October 1980. Toronto, Ontario, Canada.

Technical Report 122

DISTRIBUTION LIST

Navy

OASN (R&D, MRA&L)
CNO (OP-115, OP-987H, OP-987, OP-12, OP-01, OP-11, OP-29, OP-39, OP-59)
NAVCOMPT (NCD-7)
ONR (442 (3 copies))
CNM (MAT-072)
CNET (01, 02, N-5)
CNAVRES (02)
CNTECHTRA (016 (5 copies), N-6)
CNATRA (Library)
COMTRALANT
COMTRALANT (Educational Advisor)
COMTRAPAC (2 copies)
CO NAVPERSRANDCEN (Library (2 copies))
NAVPERSRANDCEN Liaison (021)
Superintendent NAVPGSCOL (2124, 32)
Superintendent Naval Academy Annapolis (Chairman, Behavioral Science Dept.)
CO NAVEDTRAPRODEVCE (Technical Library (2 copies))
CO NAVEDTRASUPPCENLANT (N-3)
CO NAVEDTRASUPPCENPAC (2 copies)
CO NAVTECHTRACEN Corry Station (101B, 3330, Cryptologic Training Department)
CO NAVTRAEQUIPCEN (TIC, N-001, N-002, N-09)
Center for Naval Analyses (2 copies)
OIC NODAC (2)
CO TRITRAFAC
CO NAVSUBTRACENPAC
CO FLEASWTRACENPAC
CO FLETRACEN SDIEGO
Executive Director NAVINSTPRODEVDET
VT-10 (Education Specialist)
CO NAVSUBSCOL NLON (Code 0110)
CO NAVTECHTRACEN Treasure Island (Technical Library)
TAEG Liaison, CNET 022 (5 copies)
DIR NAVEDTRAPRODEVCEDET Memphis
CO NAVAVSCOLSCOM (Code 40C)
CO NAVTECHTRACEN Meridian
COMFLETRAGRU Pearl Harbor
DIR NAVEDTRAPRODEVCEDET Meridian
CNET Liaison Officer, Williams Air Force Base
DIR NAVEDTRAPRODEVCEDET GLAKES

Air Force

Headquarters, Air Training Command (XPTD, XPT1A) Randolph Air Force Base
Air Force Human Resources Laboratory, Brooks Air Force Base

Technical Report 122

DISTRIBUTION LIST (continued)

Air Force (continued)

Air Force Office of Scientific Research/AR
4235 Strategic Training Squadron, Carswell Air Force Base

Army

Commandant, TRADOC (Technical Library)
ARI (Reference Service)
COMDT, USAIPRM (ATSG-DT-R)

Coast Guard

Commandant, Coast Guard Headquarters (G-P-1/2/42, GRT/54)

Marine Corps

CMC (OT)
CGMCDEC
Director, Marine Corps Institute
CO MARCORCOMMELECSOL

Other

Military Assistant for Human Resources, OUSDR&E, Pentagon
Institute for Defense Analyses
COM National Cryptologic School (Code E-2)

Information Exchanges

DTIC (12 copies)
DLSIE
ERIC Processing and Reference Facility, Bethesda, MD (2 copies)

**DATE
FILMED**

7-8