

AD A116381



①

Research and Development Technical Report

DELET-TR-81-0420-1

STUDIES LEADING TO THE DEVELOPMENT OF HIGH-RATE LITHIUM SULFURYL CHLORIDE BATTERY TECHNOLOGY

Faruk Marikar
Gould Inc.,
Gould Laboratories
40 Gould Center
Rolling Meadows, Illinois 60008

March 1982

First Quarterly for Period 1 September 1981 - 31 December 1981

APPROVED FOR PUBLIC RELEASE: DISTRIBUTION UNLIMITED

Prepared for:

ELECTRONICS TECHNOLOGY AND
DEVICES LABORATORY

ERADCOM

US ARMY ELECTRONICS RESEARCH AND DEVELOPMENT COMMAND
FORT MONMOUTH, NEW JERSEY 07703

DTIC
ELECTE
JUL 2 1982
S H D

DTIC FILE COPY

82 07 02 057
HISA-FM 195-78

NOTICES

Disclaimers

The citation of trade names and names of manufacturers in this report is not to be construed as official Government indorsement or approval of commercial products or services referenced herein.

Disposition

Destroy this report when it is no longer needed. Do not return it to the originator.

Unclassified

SECURITY CLASSIFICATION OF THIS PAGE (When Data Entered)

REPORT DOCUMENTATION PAGE		READ INSTRUCTIONS BEFORE COMPLETING FORM
1. REPORT NUMBER DELET-TR-81-0420-1	2. GOVT ACCESSION NO. AD-A116381	3. RECIPIENT'S CATALOG NUMBER
4. TITLE (and Subtitle) Studies Leading to the Development of High-Rate Lithium Sulfuryl Chloride Battery Technology	5. TYPE OF REPORT & PERIOD COVERED First Quarterly 9-1-81 to 12-31-81	6. PERFORMING ORG. REPORT NUMBER #1
	7. AUTHOR(s) Faruk Marikar	8. CONTRACT OR GRANT NUMBER(s) DAAK20-81-C-0420
9. PERFORMING ORGANIZATION NAME AND ADDRESS Gould Laboratories, Inc. 40 Gould Center Rolling Meadows, Illinois 60008	10. PROGRAM ELEMENT, PROJECT, TASK AREA & WORK UNIT NUMBERS 1L162705AH94-11-021	
11. CONTROLLING OFFICE NAME AND ADDRESS US Army Eict Tech & Dvcs Laboratory ATTN: DELET-PR Fort Monmouth, New Jersey 07703	12. REPORT DATE March 1982	
	13. NUMBER OF PAGES 42	
14. MONITORING AGENCY NAME & ADDRESS (if different from Controlling Office)	15. SECURITY CLASS. (of this report) Unclassified	
	15a. DECLASSIFICATION/DOWNGRADING SCHEDULE	
16. DISTRIBUTION STATEMENT (of this Report) Approved for Public Release; Distribution Unlimited		
17. DISTRIBUTION STATEMENT (of the abstract entered in Block 20, if different from Report)		
18. SUPPLEMENTARY NOTES		
19. KEY WORDS (Continue on reverse side if necessary and identify by block number) Sufuryl Chloride, lithium, primary cells, lithium batteries, high energy batteries		
20. ABSTRACT (Continue on reverse side if necessary and identify by block number) This report details the investigations carried out during the first quarter of the program relating to Contract No. DAAK20-81-C-0420, during the period September 1, 1981 to December 1, 1981. The overall aim of the program is an examination of the viability of an active electrolyte lithium/sulfuryl chloride battery system. The specific		

DD FORM 1473
1 JAN 73

EDITION OF 1 NOV 65 IS OBSOLETE

Unclassified

SECURITY CLASSIFICATION OF THIS PAGE (When Data Entered)

Unclassified

SECURITY CLASSIFICATION OF THIS PAGE(When Data Entered)

Objectives are to

- quantify the stability of lithium in sulfuryl chloride solutions
- explore the means to improve the stability of lithium, and
- establish the limits of performance of carbon/teflon cathodes in sulfuryl chloride electrolytes.

During this quarter we

- measured the rates of corrosion of lithium in sulfuryl chloride in cells and sealed capsules by microcalorimetry
- estimated the thickness of the film formed on lithium; by complex plane impedance measurements
- followed the growth of the film on cell storage, its disruption on polarization and its healing following polarization
- established the baseline cathode performance, and
- measured the conductivity and density of $\text{SO}_2\text{Cl}_2\text{-LiAlCl}_4$ electrolysis at ambient and high temperature.

We found that :

- the corrosion rate of lithium is lower in electrolytes prepared from purified SO_2Cl_2
- lithium corrosion is high in negative grounded cells initially (125 mpy after one day) but it moderates gradually (40 mpy in 10 days and 20 mpy in 23 days)
- the corrosion rate of lithium in electrolyte contained in a sealed ampule is very low (2 mpy in 10 days)
- the thickness of the LiCl film found on lithium is between 200 and 2000Å
- cathodes of 0.5 mm thickness afford a capacity of about 27 mAh/cm^2 at 10 mA/cm^2 discharge current density, and
- the 1.5M LiAlCl_4 solution in SO_2Cl_2 has a conductivity of $1.057 \times 10^{-2} \Omega^{-1} \text{ cm}^{-1}$ and a density of 1.720 kg/L at 24°C .

Unclassified

SECURITY CLASSIFICATION OF THIS PAGE(When Data Entered)

CONTENTS

	<u>Page Number</u>
List of Figures	i
List of Tables	iii
I. Introduction	1
II. Studies of Film Formation on Lithium in Sulfuryl Chloride	3
1. Complex Plane Impedance Technique	3
2. Impedance Spectra of Cells	5
3. Film Growth on Storage	8
4. Effect of Polarization	8
5. Film Growth Following Polarization	13
III. Corrosion of Lithium By Microcalorimetry	21
IV. Anode Performance In Sulfuryl Chloride	26
V. Physical Chemistry of $\text{LiAlCl}_4\text{-SO}_2\text{Cl}_2$ Solutions	29
1. Conductivity	29
2. Density	29
VI. Cathode Performance	34
VII. Summary and Future Work	42

DTIC
COPY
INSPECTED
2

Accession For	
NTIS GRANT	<input checked="" type="checkbox"/>
DAIC TAB	<input type="checkbox"/>
Unannounced	<input type="checkbox"/>
Justification	
By	
Distribution	
Availability Codes	
Special	

A

List of Figures

	<u>Page Number</u>
1. Resistance-Capacitance Network and Locus of Impedance plot	4
2. Schematic Cross Section of a 25 mm dia Cell	6
3. Complex Plane Impedance Spectrum of a Li/SO ₂ Cl ₂ Cell 4 Hours After Fill	7
4. Complex Plane Impedance Spectrum of a Li/SO ₂ Cl ₂ Cell 6 Hours After Fill	9
5. Complex Plane Impedance Spectrum of a Li/SO ₂ Cl ₂ 96 Hours After Fill	10
6. Complex Plane Impedance Spectrum of a Li/SO ₂ Cl ₂ Cell on Polarization	12
7. Complex Plane Impedance Spectrum of a Li/SO ₂ Cl ₂ Cell Polarized 200 mV 120 Hours After Fill	14
8. Complex Plane Impedance Spectrum of a Li/SO ₂ Cl ₂ Cell Following Termination of Polarization	15
9. Impedance Spectrum of the Li/SO ₂ Cl ₂ Cell 11 Days After Polarization	16
10. Impedance Spectrum of a Li/SO ₂ Cl ₂ Cell at Rest 6 Weeks After Polarization	17
11. Film Growth Following Polarization in a Li/SO ₂ Cl ₂ Cell	19

	<u>Page Number</u>
12. Heat Evolution From Li/SO ₂ Cl ₂ Cells	22
13. Corrosion Rate of Lithium Foil in SO ₂ Cl ₂ LiAlCl ₄ Solution	23
14. Corrosion Rate of Lithium Foil in SO ₂ Cl ₂ -LiAlCl ₄ Solution in the Presence of Nickel	25
15. Discharge Curves Showing Voltage Delay After 2 Days Storage	27
16. Discharge Curves Showing Voltage Delay After 7 Days Storage	28
17. Variation of the Conductivity of SO ₂ Cl ₂ -LiAlCl ₄ Solutions With Temperature	31
18. Variation of the Density of SO ₂ Cl ₂ -LiAlCl ₄ Solutions With Temperature	33
19. Discharge Profile of Li/SO ₂ Cl ₂ Cells at 10mA/cm ²	36
20. Discharge Profile of a Li/SO ₂ Cl ₂ Cell at 1mA/cm ²	37
21. Discharge Profile of a Li/SO ₂ Cl ₂ Cell at 2mA/cm ²	38
22. Discharge Profile of a Li/SO ₂ Cl ₂ Cell at 5mA/cm ²	39
23. Discharge Profile of a Li/SO ₂ Cl ₂ Cell at 20mA/cm ²	40

List of Tables

	<u>Page Number</u>
1. Film Growth on Lithium in a Li/SO ₂ Cl ₂ Cell on Storage	11
2. Film Growth on Lithium in a Li/SO ₂ Cl ₂ Cell Following Polarization	18
3. Density, Conductivity and Resistivity of LiAlCl ₄ Solutions in SO ₂ Cl ₂ at Various Temperatures	30
4. Li/SO ₂ Cl ₂ Cell Performance Data	35
5. Li/SO ₂ Cl ₂ Cell Performance at Various Current Densities	41

I. Introduction

Early work on lithium primary cells mentions both thionyl chloride and sulfuryl chloride as possible cathodic reactants.(1),(2) In the ensuing development effort thionyl chloride came to gain widespread popularity and sulfuryl chloride has suffered almost total neglect until recently (3). Li/SO₂Cl₂ cells have a higher open circuit voltage than Li/SOCl₂ cells. Also the thermal decomposition of SO₂Cl₂ giving SO₂ and Cl₂ is a simple reaction unlike that of SOCl₂ which gives products that might contribute to the safety problems on abuse and storage of cells.

The major problem with the Li/SO₂Cl₂ cell system is the high rate of corrosion of lithium in the SO₂Cl₂-LiAlCl₄ electrolyte system. Corrosion rates estimated from the initial gassing of lithium in SO₂Cl₂ solutions (3) translate to very poor shelf life. Our calorimetric studies indicated that the corrosion rate in sealed cells is much lower than that estimated from the initial gassing rate.(4) We also found by scanning electron microscopy that the surface of lithium exposed to SO₂Cl₂-LiAlCl₄ solution is covered by a chloride film similar to that found in SOCl₂ solutions.(5) The presence of such a film on the lithium anode can be expected to contribute to a certain extent of "voltage delay" upon initiation of cell discharge.

The current program was undertaken with the aim of examining the viability of an active electrolyte lithium/sulfuryl chloride battery system. Toward this aim we seek to quantify lithium stability in sulfuryl chloride solutions, explore the means to improve stability and establish reliable cathode performance at high discharge rates.

During this quarter we measured lithium corrosion in cells and sealed ampules; followed the chloride film thickness on storage and discharge; established baseline cathode performance; and measured the conductivity and density of SO₂Cl₂-LiAlCl₄ electrolyte solutions.

Prepared for: ERADCOM
Contract No.
Quarterly Progress Report

Gould Laboratories
Gould Document No. 827-001
May 10, 1982

References

1. J. J. Auburn, K. W. French, S. I. Lieberman, V. K. Shah and A. Heller, J. Electrochem. Soc., 120, 1613 (1973)
2. S. Gilman, Proceedings of 26th Power Sources Symposium p. 45, (1974).
3. S. Gilman and W. Wade, J. Electrochem. Soc, 127, 1427 (1980)
4. F. Marikar, J. Phillips, J. C. Hall and H. F. Gibbard, Paper 91 presented at the Electrochemical Society, Denver, CO, Oct. 1981
5. A. N. Dey, Thin Solid Films, 43, 131 (1977).

II. STUDIES OF FILM FORMATION ON LITHIUM IN SULFURYL CHLORIDE

Lithium, on exposure to sulfuryl chloride electrolyte solution, develops a protective film which moderates the spontaneous corrosion reaction at the interface. On storage of a Li/SO₂Cl₂ cell the film thickens, causing voltage delay on initiation of discharge. Analysis of the frequency dispersion of impedance of Li/SO₂Cl₂ cells provides an in-situ non-destructive technique of monitoring the thickness of the film so as to develop the means to mitigate the voltage delay problem.

II. 1. Complex Plane Impedance Technique

The impedance of the electrochemical cell at any given frequency f is measured using a low amplitude ac signal (ca 5 mV peak to peak) applied to the cell at rest or under polarization. For a parallelly coupled resistance and capacitance which is the most frequently encountered circuit element in the studies described here, the impedance Z_e can be represented as a function of the resistance R , the capacitance C and the angular frequency $\omega (=2\pi f)$ by either of the following equations.

$$Z_e = \frac{R}{1+j\omega CR} = \frac{R}{1+(\omega CR)^2} (1-j\omega CR)$$

$$Z_e = \frac{R}{[1+(\omega CR)^2]^{1/2}} \arg [\tan^{-1} (-\omega CR)]$$

The locus of impedance for this simple electrical network is a semicircle as shown in Figure 1. The addition of a resistance in series with the circuit shown will cause the semicircular plot to shift to the right on the x-axis. It is customary in presenting electrochemical results, to employ the first quadrant by plotting the negative reactance on the y-axis.

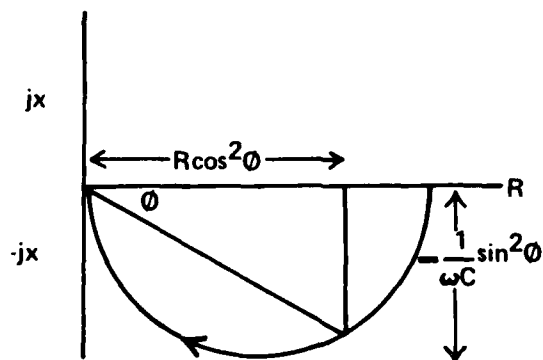
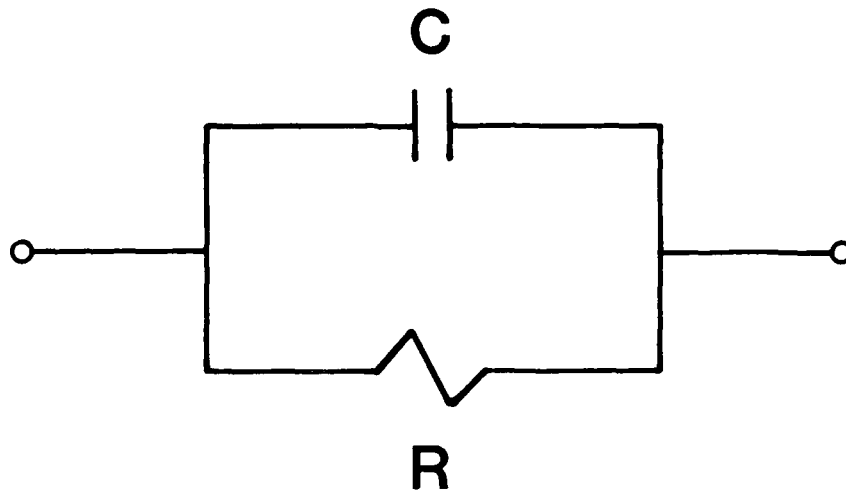

(1576)

Figure 1 Resistance - Capacitance Network and Locus of Impedance Plot

II. 2. Impedance Spectra of Cells

The cells used in the impedance studies are of the design illustrated in Figure 2. The circular anode of 0.51 mm thick lithium foil with 3.3 cm² area was placed at the bottom of the 304 stainless steel case. The cathode of 90-10 Shawinigan black-teflon mixture pressed into expanded nickel to a thickness of 0.4 to 0.5 mm was spot welded to the feedthrough. The electrodes were separated using a 0.13 mm thick non-woven glass mat. After the case and cover were welded 1.5 M LiAlCl₄ solution in SO₂Cl₂ was added through the fill tube which was then closed and soldered. The cell was stored at 25°C.

The complex plane impedance spectrum of a Li/SO₂Cl₂ cell, four hours after filling with electrolyte is shown in Figure 3. The frequency range available for impedance measurement was 25 KHz to 0.05 Hz. The intersection of the high frequency end of the semicircle with the x-axis gives a measure of the sum of the terminal and electrolyte resistances (R_{e1}). The center of the first semicircle lies below the X-axis. The resistance of the circuit element is 28Ω and the capacitance calculated from the frequency at the maximum of the semicircle is 1.14 μF. This capacitance value is over an order of magnitude smaller than the 10 to 40 μF/cm² expected of solid/electrolyte solution interfaces. Based on the changes in the electrical characteristics on storage and polarization of the cell (described below) the reactance obtained can be attributed to the presence of a dielectric film on the lithium anode. The presence of a film of LiCl on lithium in SOCl₂-based electrolytes is well known. A similar film on lithium in SO₂Cl₂-electrolytes was reported by us in our proposal to ERADCOM (RFP No. DAAK20-81-R-0275).

The thickness of the film d can be calculated from the capacitance C using the equation

$$C = \frac{\epsilon A}{3.6 \times 10^{12} \pi d}$$

where A is the geometric area and ε the dielectric constant of LiCl is 11.05. The film thickness, four hours after cell filling is 283Å.

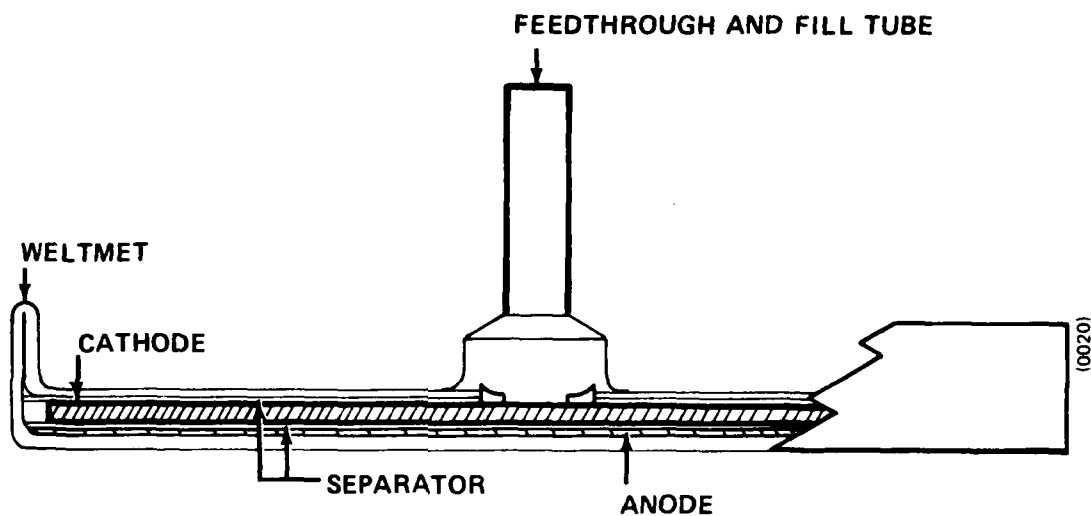

Figure 2 Schematic Cross Section of a 25mm DIA Cell

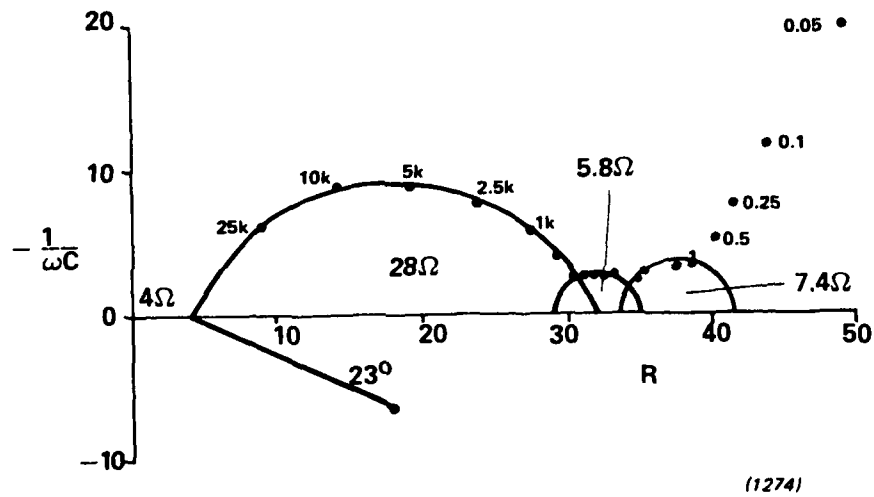

Figure 3 Complex Plane Impedance Spectrum of a Li/SO₂Cl₂ Cell
4 Hours after Fill

The semicircles observed at lower frequencies arise from resistance-capacitance couples associated with charge transfer impedances and inter-particle contact impedances in the cell. When the semicircle at the high frequency end grows in size, the low frequency side degrades in resolution and the frequency range available is no longer sufficient to fully delineate the spectrum. This effect is already evident in Figure 4 which is a spectrum obtained two hours after the one in Figure 3.

II. 3. Film Growth on Storage

The spectrum in Figure 5 obtained four days after filling the cell shows that the resistance has increased five-fold. The fine structure of the semicircle is probably due to coverage of the case metal by a film of LiCl. The increase of R_{e1} from 4 to 10 ohms is indicative of an increase in ionic resistivity due to a thick porous LiCl film present on the thin compact non-porous film. The increase in resistance and the increase in compact film thickness on storage of the cell are shown in Table 1. Film thickness increases from an initial 283Å to 1410Å in about 17 days. An increase in film resistivity at high thicknesses is also observable. On exposure of lithium to SO_2Cl_2 containing $LiAlCl_4$, reduction of a certain amount of aluminum can be expected to occur. The initially formed LiCl film is thus in-situ doped with Al^{3+} ions contributing to a high concentration of Schottky defects, and increased Li^+ ion conductivity. The extent of doping decreases during subsequent film build-up so that the average film resistivity rises.

II. 4. Effect of Polarization

The presence of a resistive film on the lithium anode causes the cell voltage to be depressed upon initiation of cell discharge. The subsequent recovery of the voltage (characteristic of the phenomenon of "voltage delay") occurs due to the decrease in film resistance on polarization as is evident in Figure 6. The film resistance of 85Ω on open circuit is progressively reduced to 58Ω , 39Ω and 31.5Ω on polarization by 0.1, 0.2 and 0.3V respectively. There is an approximately 1.5Ω increase in electrolyte resistance due to the addition to the porous film caused by disruption of the compact film. The

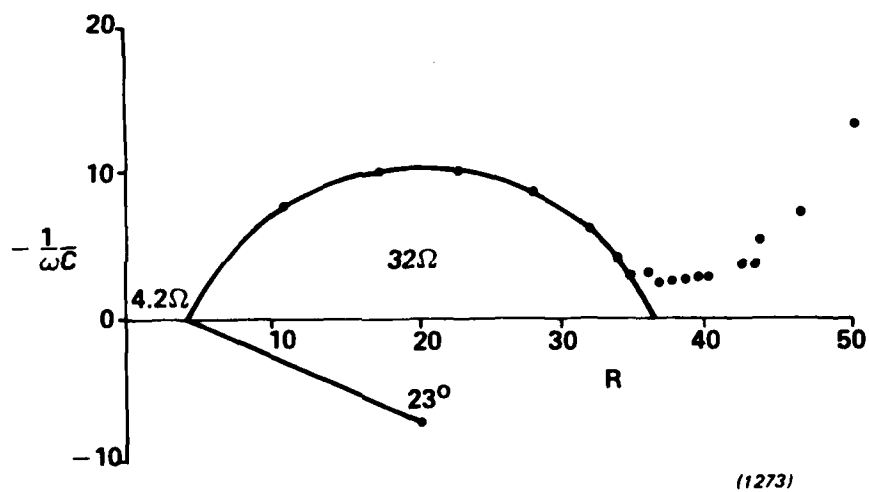
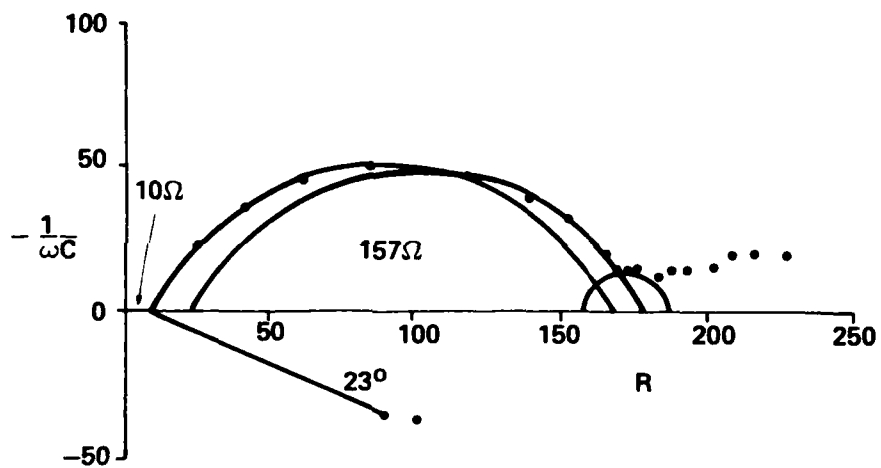

Figure 4 Complex Plane Impedance Spectrum of a $\text{Li}/\text{SO}_2\text{Cl}_2$ Cell
6 Hours after Fill



(1272)

Figure 5 Complex Plane Impedance Spectrum of a $\text{Li}/\text{SO}_2\text{Cl}_2$ Cell
96 Hours after Fill

Table 1 Film Growth on Lithium in a $\text{Li}/\text{SO}_2\text{Cl}_2$ Cell on Storage

TIME HOURS	RESISTANCE Ω	CAPACITANCE $\mu\text{F}/\text{cm}^2$	THICKNESS \AA	RESISTIVITY $10^7 \Omega \text{ cm}$
4	28	0.345	283	3.3
6	32	0.188	520	2.0
96	157	0.134	729	7.1
412	348	0.069	1410	8.2

(1291)

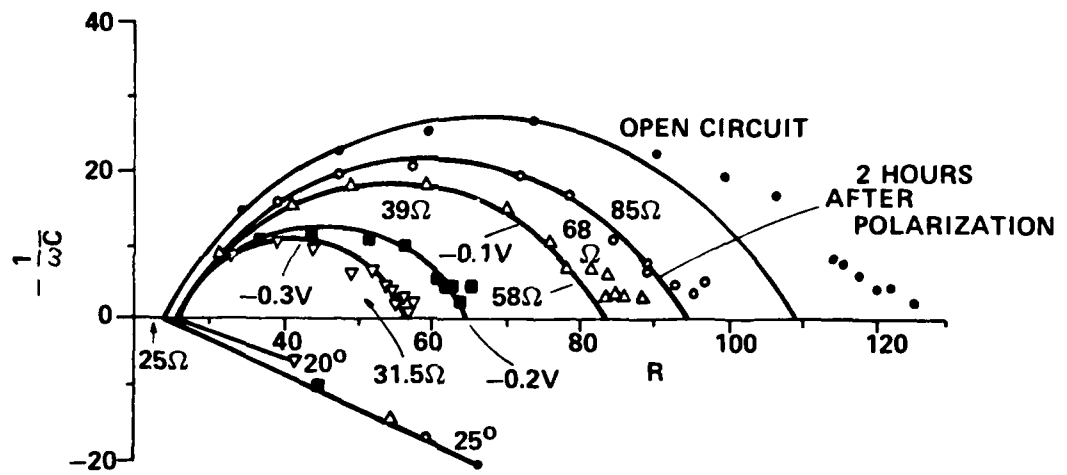

(1281)

Figure 6 Complex Plane Impedance Spectrum of a Li/SO₂Cl₂ Cell on Polarization

film builds up in thickness quite rapidly on leaving the cell on open circuit after polarization.

Figure 7 shows the impedance spectrum of a cell on 0.2V polarization for five hours. The film resistance is reduced to 10.8Ω which amounts to a film thickness of 140\AA . The low frequency region of the spectrum is fairly well resolved. If it is assumed that the semi-circle immediately following the one due to the film arises from charge transfer across the Li/LiCl interface, the capacitance associated with this circuit element indicates a roughness factor of about 50 for this interface. The Li/LiCl interface is thus, far from smooth on a micro-scale and the LiCl crystals are expected to be finegrained.

The third and the ill-resolved fourth semicircle probably arise from the inter-particle contact, and the carbon-nickel contact impedances at the cathode. The final large semicircle is not completely resolvable within the available frequency range of measurement employed here. Approximate calculations indicate that the capacitance is about 0.4 farads. This value would be expected of the carbon/electrolyte double layer capacitance at the Shawinigan Black ($66\text{m}^2/\text{g}$ BET surface area) cathode. The charge transfer resistance of 31.5Ω even at 0.2V polarization on a very large interfacial area, points to the small magnitude of the exchange current density associated with the SO_2Cl_2 reduction process.

II. 5. Film Growth Following Polarization

The recovery of resistance due to film growth was followed by the complex plane impedance technique. Figure 8 shows the semicircles associated with the LiCl film on 300 mV polarization and 5, 15, 40, 120, 180, 300 and 1200 minutes following termination of polarization. The corresponding resistances are 12, 23, 38, 64, 105, 121, 128 and 182 ohms respectively. The film resistance continues to increase further; the spectrum in Figure 9 obtained 11 days after polarization shows a resistance of 348Ω and that in Figure 10, 6 weeks after polarization indicates a resistance of 920Ω . There is also a significant increase in electrolyte resistance on extended storage of the cell.

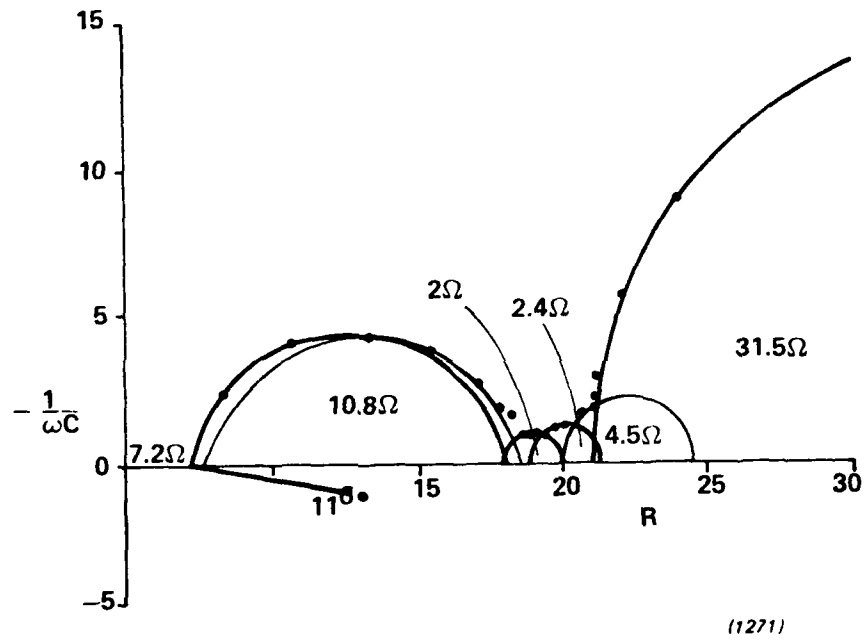

Figure 7 Complex Plane Impedance Spectrum of a Li/SO₂Cl₂ Cell
Polarized 200mV 120 Hours after Fill

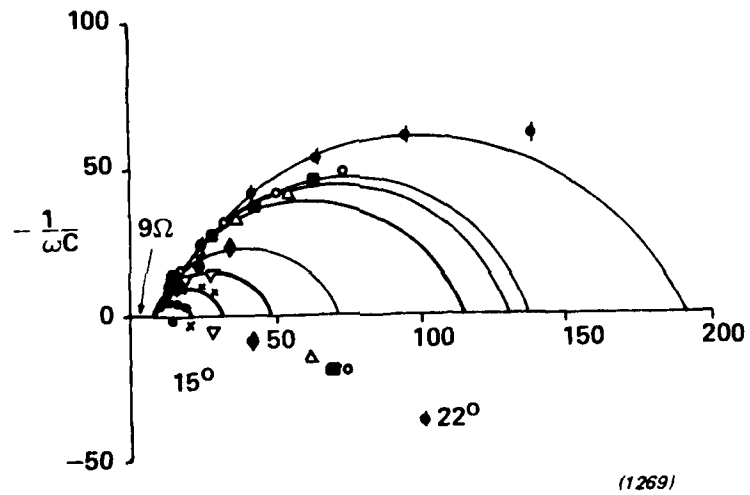

Figure 8 Complex Plane Impedance Spectrum of a $\text{Li}/\text{SO}_2\text{Cl}_2$ Cell Following Termination of Polarization

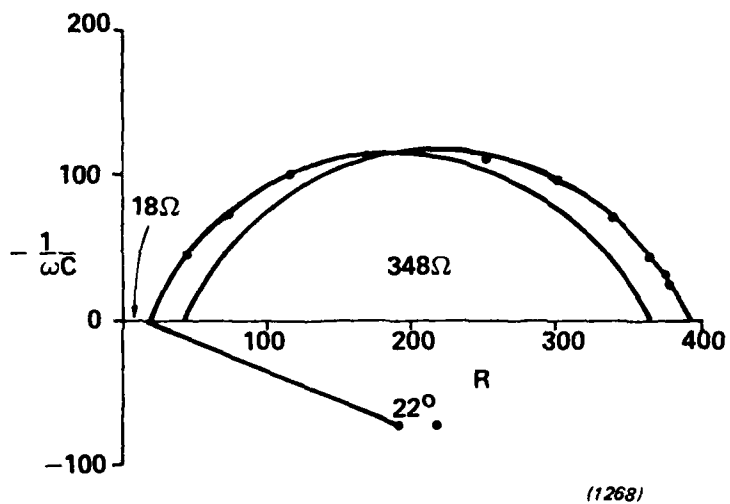
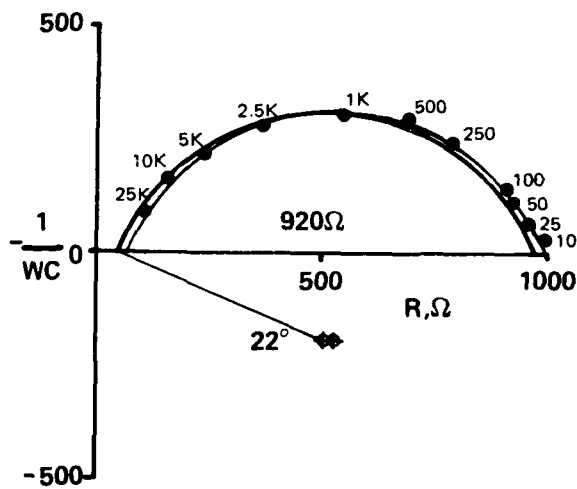

Figure 9 Impedance Spectrum of the $\text{Li}/\text{SO}_2\text{Cl}_2$ Cell 11 Days After Polarization



(1518)

Figure 10 Impedance Spectrum of a Li/SO₂Cl₂ Cell at Rest
6 Weeks after Polarization

Prepared for: ERADCOM
Contract No. DAAK20-81-C-0420
Quarterly Progress Report

Gould Laboratories
Gould Document No. 827-001
01/04/82

Table 2 Film Growth on Lithium in a $\text{Li}/\text{SO}_2\text{Cl}_2$ Cell Following Polarization

TIME MIN.	RESISTANCE Ω	CAPACITANCE $\mu\text{F}/\text{cm}^2$	THICKNESS \AA	RESISTIVITY $10^7 \Omega \text{ cm}$
0	12.0	0.618	158	2.5
5	23.0	0.524	186	4.1
15	38.0	0.509	192	6.5
40	64.4	0.403	242	8.8
120	104.5	0.201	487	7.1
180	121.0	0.166	588	6.8
300	127.5	0.151	646	6.5
1200	182.0	0.110	886	6.8
16000	348.0	0.069	1410	8.2
60000	920.0	0.052	1864	16.0

(1290)

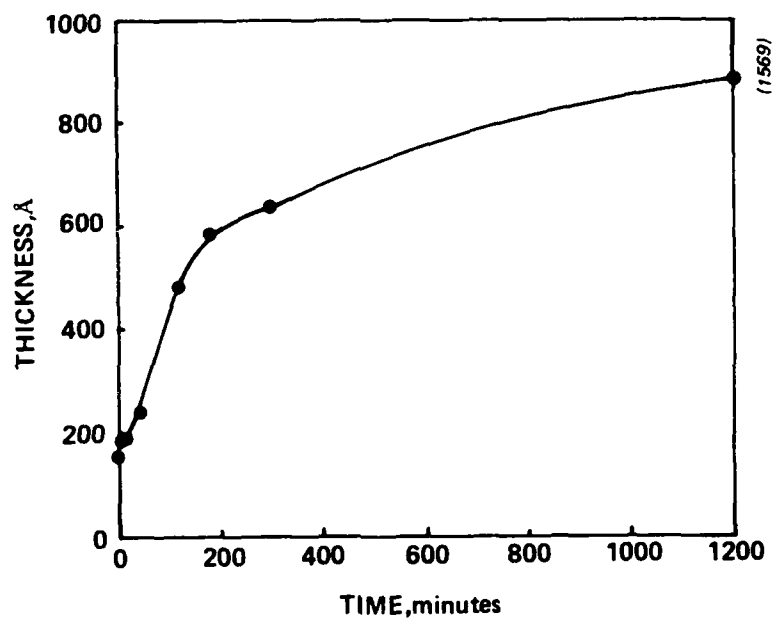

Figure 11 Film Growth following Polarization in a $\text{Li/SO}_2\text{Cl}_2$ Cell

Prepared for: ERADCOM
Contract No.
Quarterly Progress Report

Gould Laboratories
Gould Document No. 827-001
May 10, 1982

The capacitance, film thickness and film resistivity following polarization are listed in Table 2. A thickness vs time plot during the initial period of recovery is shown in Figure 11. The film thickens rapidly until it approaches the thickness value prior to polarization. The rate of build-up then slackens abruptly, and some twenty hours after termination of polarization, the rate is virtually identical to that before polarization.

The thickness and resistance associated with the film on lithium in SO_2Cl_2 is about an order of magnitude higher than that for films in SOCl_2 in cells built in this laboratory. However, high thickness and resistance in Li/SOCl_2 has been found in commercial cells stored for several months.

III. CORROSION OF LITHIUM BY MICROCALORIMETRY

The main problem in the development of the Li/SO₂Cl₂ system is the high rate of anode corrosion that has been observed. Gilman and Wade report a gassing rate for lithium in SO₂Cl₂ electrolyte which amounts to an initial corrosion rate of about 100 μm/day. [J. Electrochem. Soc., 127, 1427 (1980)].

We employed microcalorimetry to measure the heat output due to corrosion and converted the heats to corrosion rates knowing the enthalpy of the corrosion reaction. A Tronac Model 351-R calorimeter capable of measuring heat outputs down to 1 μW was used for these studies. The enthalpy of the corrosion reaction

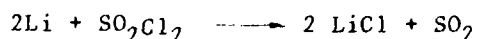

was determined from the excess heat on low polarization and is equal to -765.6 KJ/mol.

The heat evolved from sealed 25 mm dia cells (of construction in Figure 2) containing 1.5M LiAlCl₄ in SO₂Cl₂ electrolyte is shown in Figure 12. Corrosion is high when the electrolyte is prepared from reagent grade (MCB) sulfuryl chloride. When the reagent is distilled, refluxed over lithium and distilled again and then used, corrosion rate diminishes considerably. The highest corrosion rate measured here is an order of magnitude lower than the rate estimated from the initial gassing rate found by Gilman and Wade. In translating the heat outputs to corrosion rates it was assumed that only one face of the lithium foil pressed into the metal case is available for corrosion. If both the faces i.e., 2 x 3.3 cm² are indeed available for corrosion the effective corrosion rate would be half that shown in Figure 12.

The corrosion rate of lithium in the cell containing purified SO₂Cl₂ is about 125 mils per year, one day after cell filling. It decreases to 40 mpy after 10 days and 20 mpy after 23 days. The corrosion rate continues to decrease on further storage.

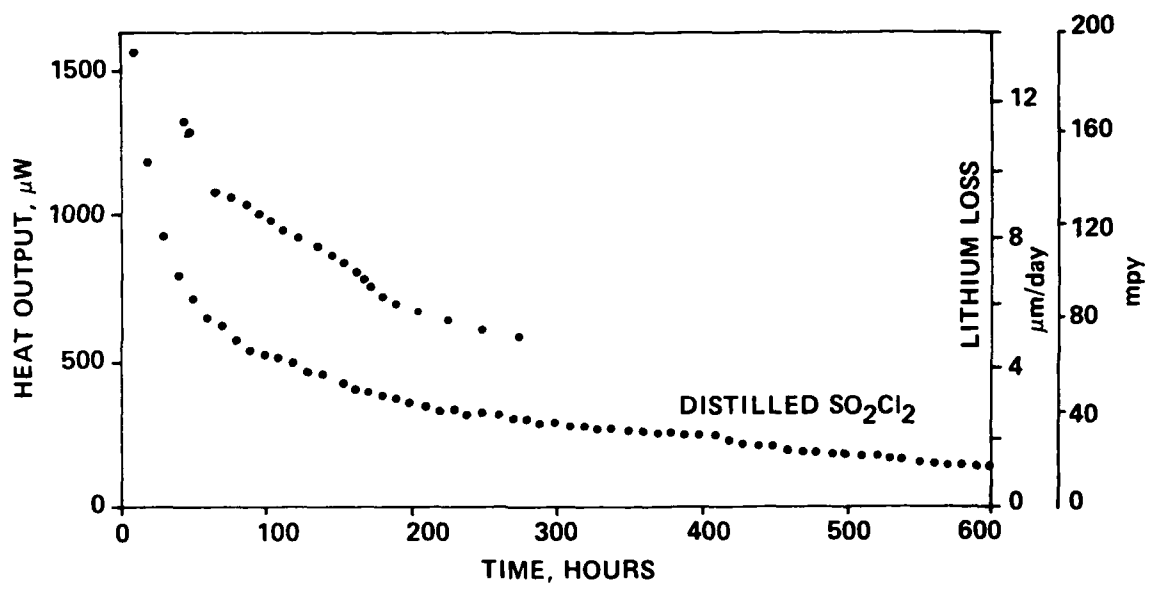

(1278)

Figure 12 Heat Evolution from Li/SO₂Cl₂ Cells

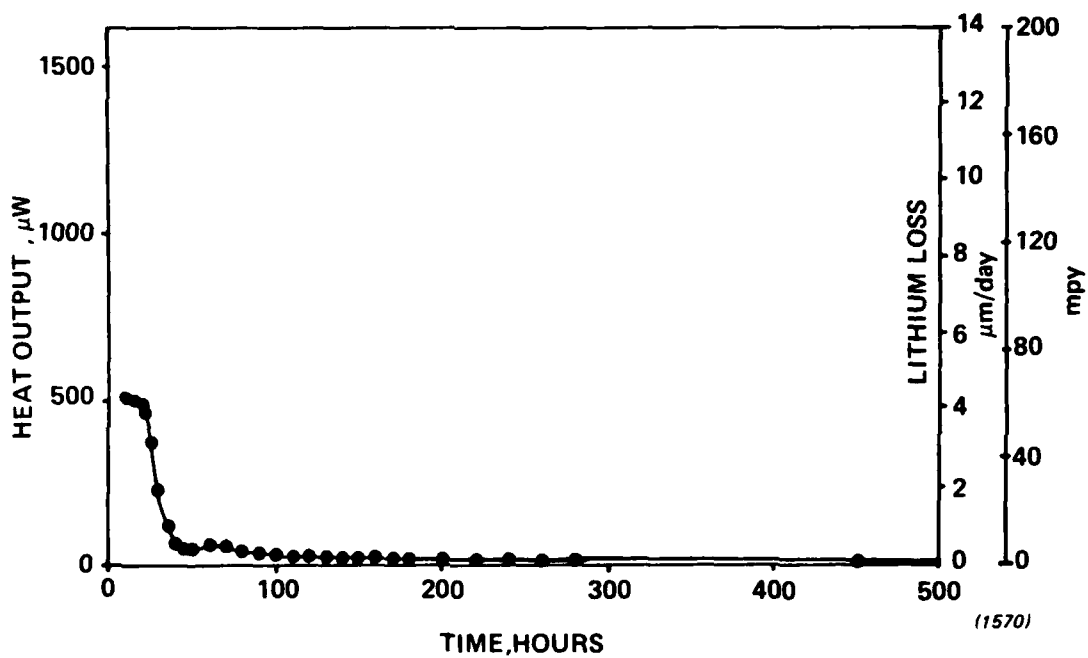

Figure 13 Corrosion Rate of Lithium Foil in $\text{SO}_2\text{Cl}_2 - \text{LiAlCl}_4$ Solution

In order to evaluate the corrosion rate in the absence of contact of lithium with the cell case, we studied the heat output from sealed glass ampules containing lithium foil in 3 ml electrolyte solution. Figure 13 shows the heat evolution due to exposure of 3.3 cm² area lithium foil. The heat output is high during the first day of exposure but it diminishes thereafter and amounts to only about 6 mpy corrosion rate after the second day. Corrosion is only about 2 mpy after ten days, and the decrease continues on further storage.

Figure 14 shows the effect on corrosion rate of contacting the lithium foil with a piece of nickel foil of equal geometric area. In the absence of nickel both the reduction of SO₂Cl₂ and the oxidation of Li to Li⁺ have to occur on the lithium surface. Nickel provides a convenient substrate for the reduction reaction. Probably because of this the film formed on lithium could be more compact and the corrosion reaction moderates much more swiftly and smoothly. The corrosion rate is 16 mpy at the end of the first day and it drops to 2 mpy in eight days.

The rates of corrosion of lithium exposed to SO₂Cl₂ electrolyte in sealed ampules is much smaller than that measured in sealed cells. Since contacting the lithium with nickel in an ampule did not accelerate corrosion, the high rate of corrosion observed in the cell is not due to having the lithium pressed to the metal case. The effect on corrosion of contamination from various sources including stainless steel of which the case is made, will be investigated in the next quarter.

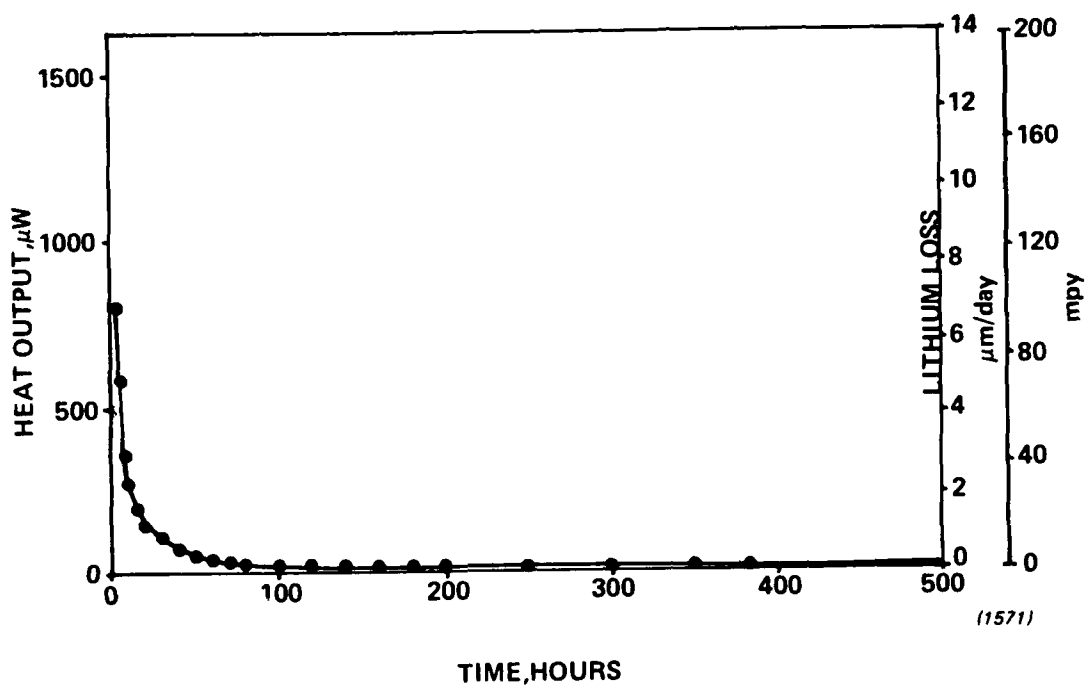

Figure 14 Corrosion Rate of Lithium Foil in $\text{SO}_2\text{Cl}_2 - \text{LiAlCl}_4$ Solution in the presence of Nickel

IV. ANODE PERFORMANCE IN SULFURYL CHLORIDE

The thick film formed on lithium exposed to SO_2Cl_2 solutions is expected to give rise to a certain degree of voltage delay on initiation of discharge. 51 mm dia cells of construction similar to that already described (Figure 2) were built with 0.51 mm thick cathodes and lithium foil anodes. The cells were closed with Swagelok caps and stored at 30°C and 60°C. Figure 15 and Figure 16 show the discharge curves of cells at room temperature and 10mA/cm² current density following two and seven days of storage respectively. Voltage delay is not a serious problem on two days storage at 30°C. After seven days, the voltage falls to 1.2V and then recovers past 2V in about 15 minutes. At 60°C, serious delay is evident even after 2 days storage. After seven days storage the voltage hardly rises past 2V during the entire discharge. The increase in depression of the discharge voltage that accompanies the delay indicates limited disruption of the thick anode film during discharge. It is unclear why the discharge capacity in cells stored at 60°C is lower, since the cells are expected to be cathode limited (the anodes have three times excess capacity).

In addition to causing voltage delay, corrosion of lithium can also be expected to affect the discharge capacity of anode-limited cells or cells of balanced chemistry. If it is assumed that all the SO_2Cl_2 contained in the porous cathode can be subjected to 2-electron reduction, the theoretical capacity of the 0.51 mm cathode in the 51 mm dia cell would be about 0.4 Ah. This capacity can be matched by an anode of .13 mm (0.005") lithium foil. Four cells containing 0.51 mm thick cathodes and 0.13 mm lithium anodes were built and stored at 35°C to evaluate the capacity loss due to lithium consumption. Little capacity could be realized on discharge at 10mA/cm² after four days of storage.

It is hence necessary to alleviate the corrosion problem in Li/ SO_2Cl_2 cells before meaningful studies on extended storage can be performed.

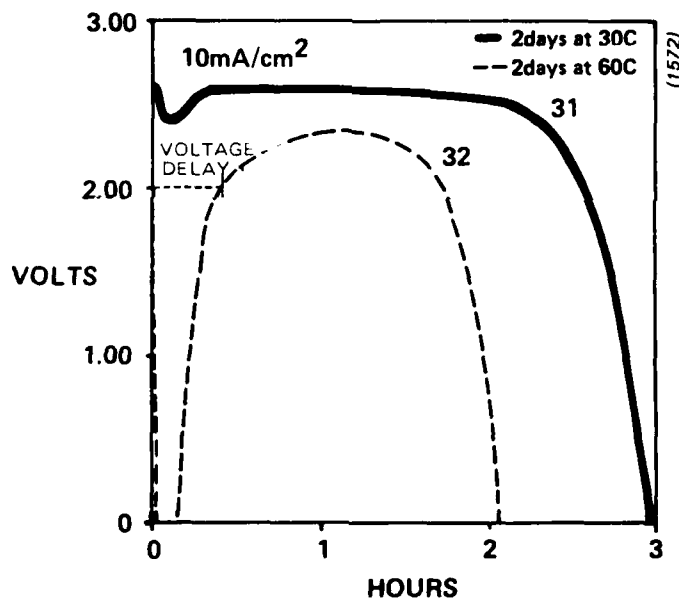

Figure 15 Discharge Curves showing Voltage Delay after Two Days Storage

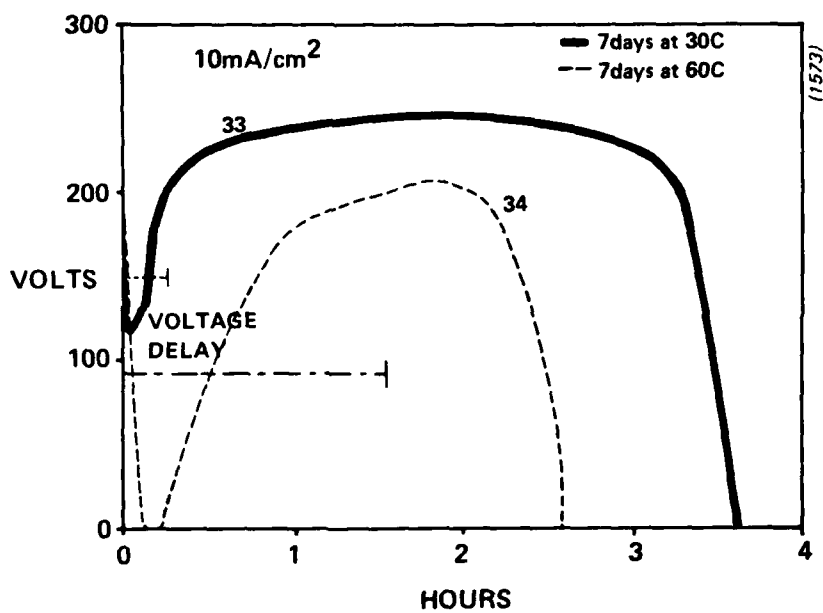

Figure 16 Discharge Curves showing Voltage Delay after Seven Days Storage

V. PHYSICAL CHEMISTRY OF LiAlCl_4 - SO_2Cl_2 SOLUTIONS

The electrolyte physical properties of most interest in the development of the $\text{Li}/\text{SO}_2\text{Cl}_2$ system are the conductivity and density of the solutions at various temperatures and concentrations. The range of temperatures between ambient to that approaching boiling is covered in this quarter. The measurements will be extended to lower temperatures during the next quarter. LiAlCl_4 concentrations of 0.5, 1.0, 1.5 and 2.0M were employed.

V. 1. Conductivity

100ml of the desired solution was prepared from double distilled (second distillation over lithium) MCB reagent grade SO_2Cl_2 and LiAlCl_4 from Anderson Physics Laboratory. The solution was mixed for over ninety minutes. 35ml of the solution was placed in a dry Jones-type conductivity cell (Beckman CEL 6J100). The cell was then placed in a water bath at ambient temperature. After one hour a reading in ohms was taken using a Beckman conductivity bridge (RC-18A), and the temperature noted. The temperature of the bath was then increased to 40C. After one hour at 40C a second reading was taken. The above procedure was repeated at 60C. All four solutions were run in a similar manner. The cell constant was determined, using 0.01 M KCl, before each series of measurements. The results are presented in Table 3. The conductivity is reported in $(\text{ohm-meter})^{-1}$, and the resistivity is in ohm-cm. Figure 17 is a plot of the inverse of the temperature in Kelvin versus the log of conductivity for the four concentrations. The plots are nearly linear in this range of temperature. The increase in slope of the plots with increase in concentration points to the high degree of association of the salt at high concentrations.

V. 2. Density

The solutions were placed in a dry pre-weighed 50ml volumetric stoppered flask. The sealed flask was placed in a water bath at ambient temperature for one hour. At the end of one hour the level in the flask was adjusted to 50ml, the flask was removed from the water bath, dried and weighed. The temperature of the bath was then increased to 40C. After one

TABLE 3

DENSITY, CONDUCTIVITY AND RESISTIVITY
OF LiAlCl_4 SOLUTIONS IN SO_2Cl_2
AT VARIOUS TEMPERATURES

<u>LiAlCl_4 Molarity</u>	<u>Temperature (°C)</u>	<u>Density (Kg/ℓ)</u>	<u>Conductivity (Ωm)⁻¹</u>	<u>Resistivity (Ωcm)</u>
0.5M	22	1.6893	0.294	339.82
	41	1.6509	0.301	332.67
	61	1.6101	0.308	324.27
1.0M	23	1.7041	0.693	144.33
	40	1.6722	0.780	128.23
	60	1.6319	0.895	111.78
1.5M	24	1.7204	1.057	94.61
	40	1.6923	1.230	81.32
	60	1.65658	1.476	67.77
2.0M	24	1.7376	1.245	80.33
	40	1.7051	1.505	66.43
	50	1.6823*		
	60	-	1.815	55.09

* Approximate values; boiling occurred at this temperature.

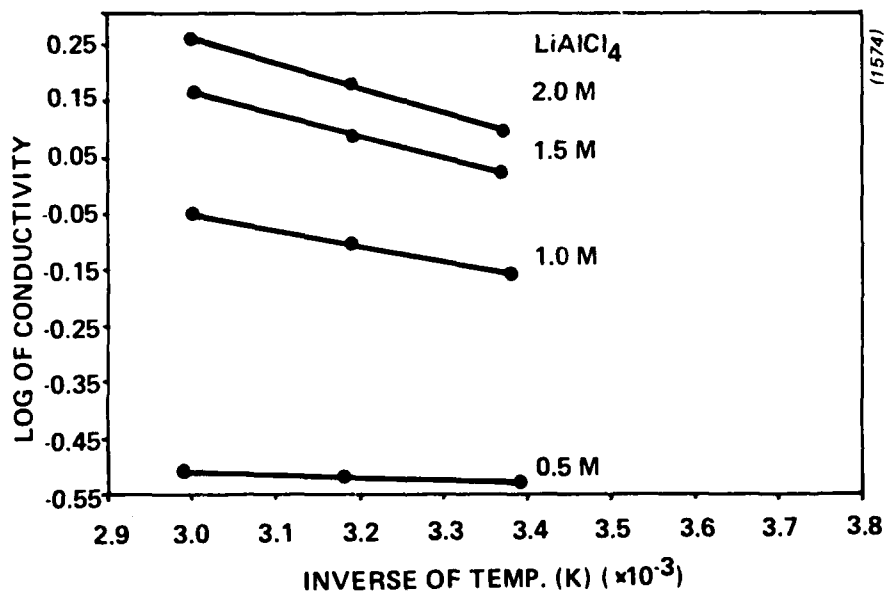

Figure 17 Variation of the Conductivity of SO_2Cl_2 - LiAlCl_4 Solutions with Temperature

Prepared for: ERADCOM
Contract No.
Quarterly Progress Report

Gould Laboratories
Gould Document No. 827-001
May 10, 1982

hour at 40C, the level in the flask was adjusted to 50ml, the flask was again dried and weighed. The above procedure was repeated at 60C. The dry weight of the flask was determined before each series of measurements. In determining the density allowance was made for the expansion in volume of the flask.

The results are presented in Table 3 and Figure 18. At 60C SO_2Cl_2 solutions containing 1.5 M and 2.0 M LiAlCl_4 appeared to boil. The accurate level of the solutions was difficult to determine and hence the accuracy of these measurements is less than that for the rest of the measurements. The highest temperature at which measurements were made for the 2.0 M solution was 50C.

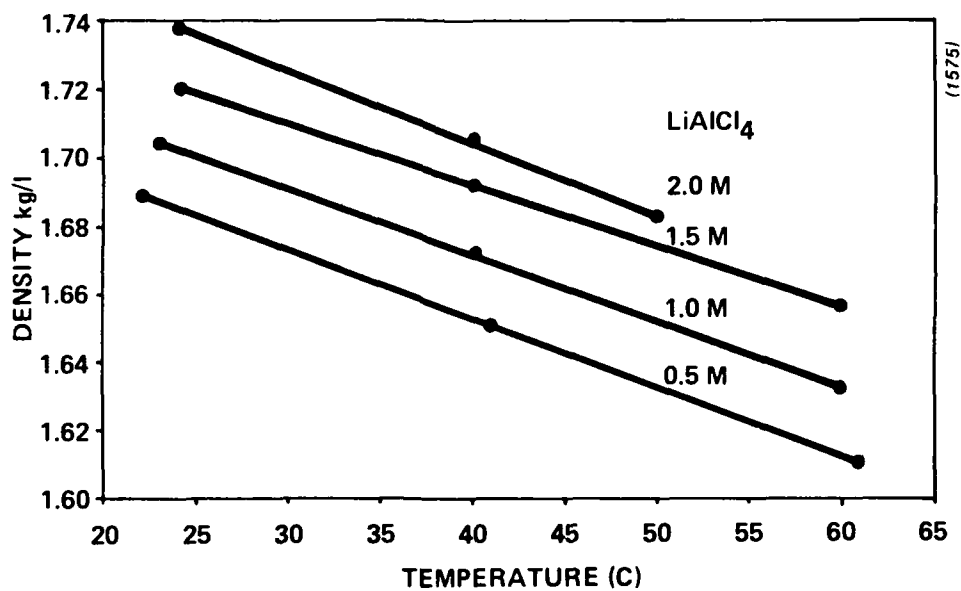

Figure 18 Variation of the Density of SO_2Cl_2 - LiAlCl_4 Solutions with Temperature

VI. CATHODE PERFORMANCE

Although the optimization of cathode performance is not one of the major goals of this program it is necessary to acquire data on baseline performance in order to (i) insure that the cells where anode performance is evaluated are indeed anode limited and (ii) monitor the effect of additives incorporated to improve anode stability, on cathode performance.

Performance data on twenty, 51mm dia cells, most of them discharged at 10 mA/cm² is shown in Table 4. The cells were discharged after 10 minutes on open circuit following filling. There was considerable scatter in the capacities obtained in the early cells. Minimization of storage time of the electrolyte reduced the scatter considerably. It was speculated that storage of the electrolyte solution without exposure to light would reduce or eliminate any photo-induced decomposition reaction that might lead to lower cathode capacity in the cell. Cells M12 to M19 were operated with electrolyte stored in the dark and used within 3 days of preparation. There is fair reproductibility of the capacity obtained, which is approximately 0.4 Ah. The discharge curves for cells M18 and M19 are shown in Figure 19. The theoretical capacity based on the consumption of all the SO₂Cl₂ in the cathode by 2-electron reduction is approximately 0.4 Ah. A certain degree of cathode swelling is hence indicated and this has been confirmed by post-operative analysis of discharged cells.

Discharge curves at other current densities viz., 1, 2, 5, and 20 mA/cm² are given in Figures 20, 21, 22 and 23 respectively. The discharge times and capacities obtained are listed in Table 5. There is again considerable variation in performance especially at the lower current densities. The large capacities obtained are a result of significant expansion of the cathode over the extended discharge time. The possible influence of spacing of the bottom case and top cover in welded cells on limiting cathode expansion and contributing to variable capacity will be examined during the next quarter.

TABLE 4

Li/SO₂Cl₂ Cell Performance Data

Cell #	Batch #	Carbon/Teflon Weight g	Electrolyte Age h	Current Density mA/cm ²	Capacity Ah
M1	38	0.5	16	10	0.285
M2	38	0.5	19	5	0.336
M2A	38	0.5	64	5	0.375
M3	38	0.5	40	10	0.275
M4	38	0.5	160	10	0.130
M5	38	0.4	163	10	0.194
M6	38	0.4	187	10	0.115
M7	38	0.4	211	10	0.249
M8	42	0.4	12	10	0.365
M9	42	0.4	36	10	0.384
M10	42	0.45	18	10	0.390
M11	42	0.45	90	10	0.310
M12	42	0.45	1	10	0.366
M13	42	0.45	1	10	0.455
M14	42	0.45	1	10	0.347
M15	42	0.45	1	10	0.492
M16	42	0.45	1	10	0.398
M17	42	0.45	3	10	0.291
M18	42	0.45	72	10	0.413
M19	42	0.45	75	10	0.416

[Sealed, 51mm dia cells; 15cm² electrode area; SO₂Cl₂-1.5M LiAlCl₄ electrolyte; 0.51mm anode; 0.51mm 90/10 Shawinigan Black-Teflon Cathode. Cells M12-M19 with electrolyte stored in the dark.]

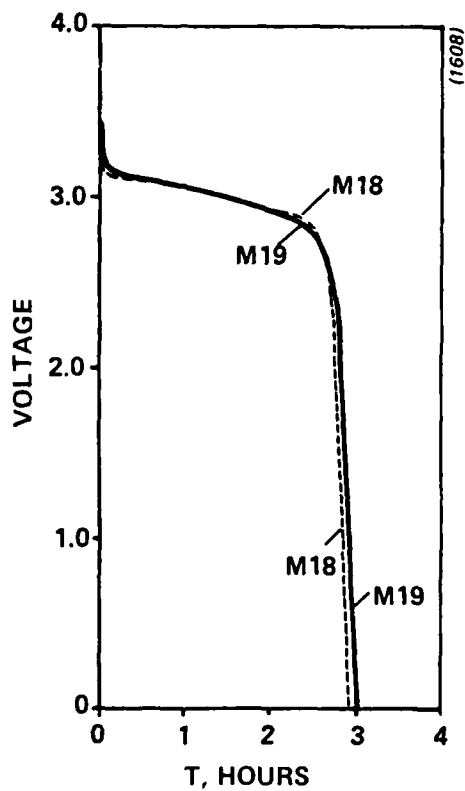

Figure 19 Discharge Profile of $\text{Li}/\text{SO}_2\text{Cl}_2$ Cells at $10\text{mA}/\text{cm}^2$
(Conditions as in Table 5)

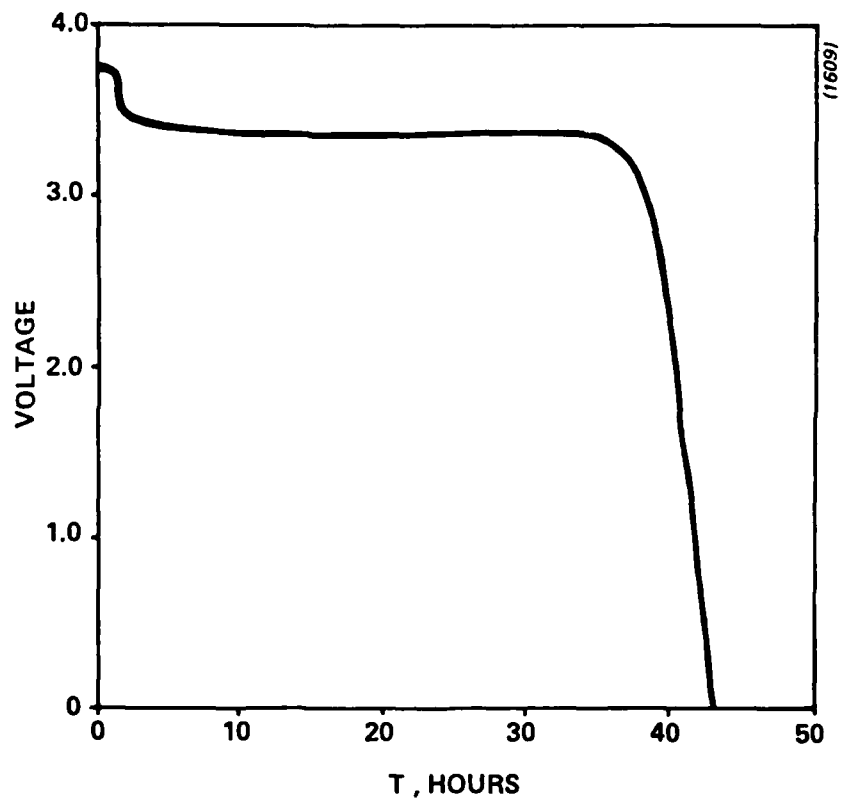

Figure 20 Discharge Profile of a Li/SO₂Cl₂ Cell at 1mA/cm²
(Conditions as in Table 5)

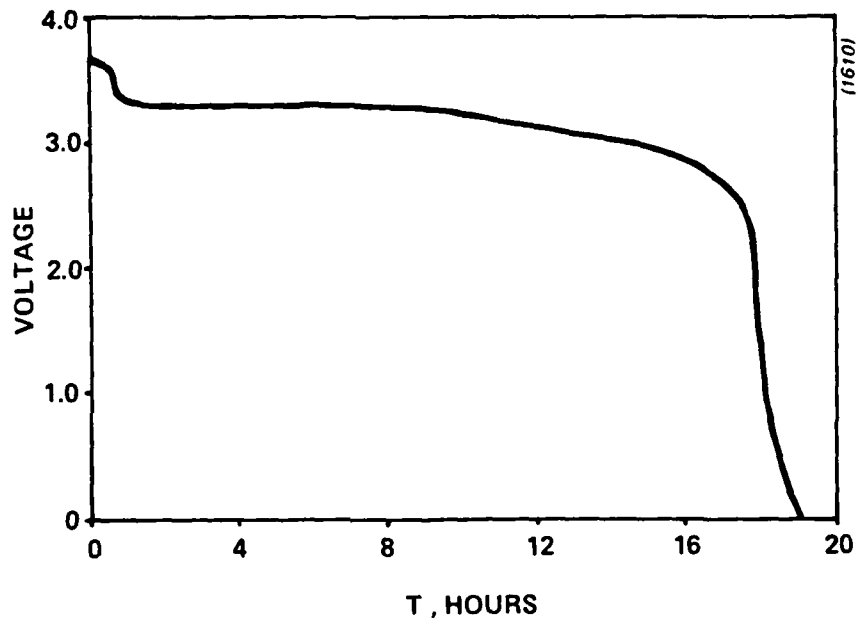

Figure 21 Discharge Profile of a $\text{Li}/\text{SO}_2\text{Cl}_2$ Cell at $2\text{mA}/\text{cm}^2$
(Conditions as in Table 5)

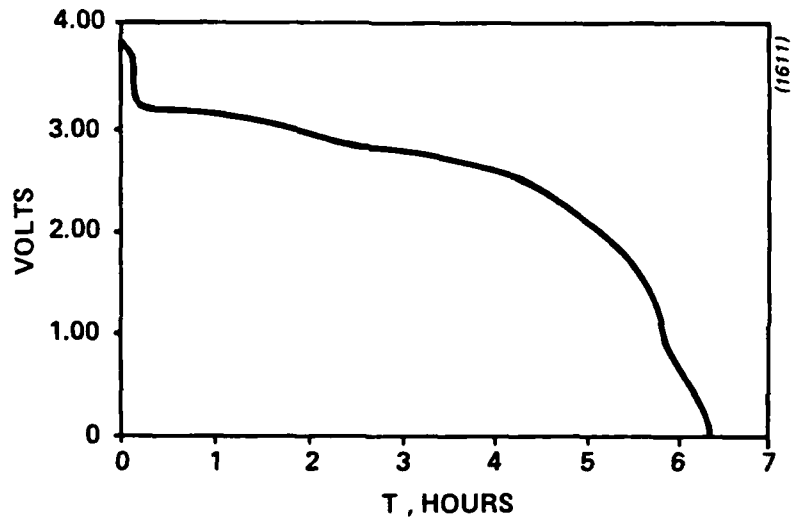

Figure 22 Discharge Profile of a Li/SO₂Cl₂ Cell at 5mA/cm²
(Conditions as in Table 5)

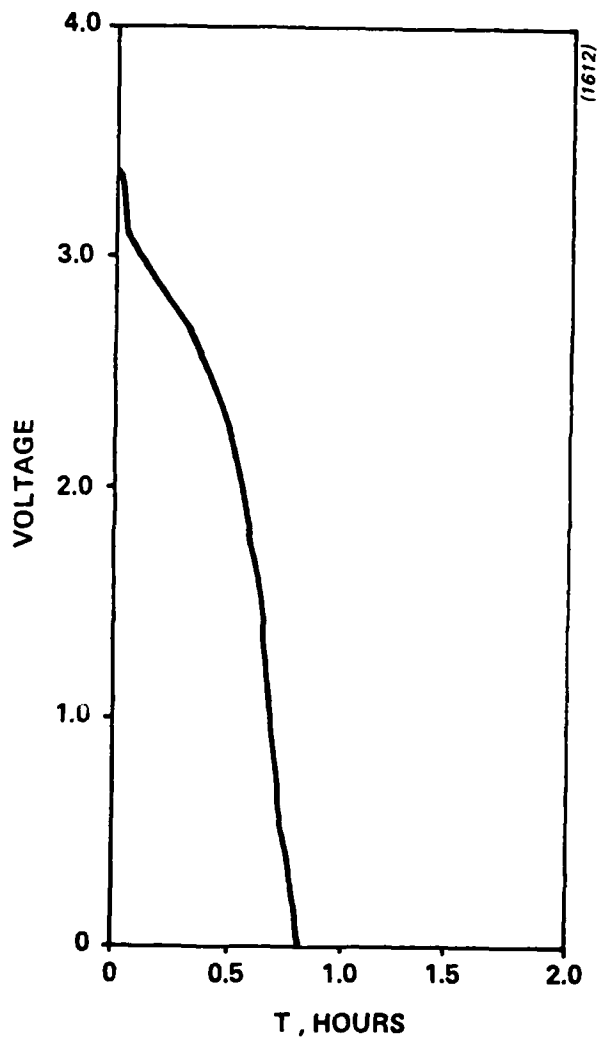

Figure 23 Discharge Profile of a Li/SO₂Cl₂ Cell
at 20mA/cm²
(Conditions as in Table 5)

TABLE 5

Li/SO₂Cl₂ Cell Performance At Various Current Densities

Cell	Current Density mA/cm ²	Discharge Time, hrs	Capacity Ah
M27	1	40.2	0.603
M28	2	77.7	0.531
M29	2	22.9	0.686
M23	5	4.0	0.300
M24	5	4.9	0.366
M25	5	3.9	0.291
M26	5	3.3	0.250
M30	5	4.5	0.334
M20	20	0.5	0.159
M22	20	0.5	0.169

[Sealed, 51mm dia cells; 15cm² electrode area; SO₂Cl₂-1.5M LiAlCl₄ electrolyte; 0.51mm anode; 0.51mm 90/10 Shawinigan Black-Teflon Cathode.]

VII. SUMMARY AND FUTURE WORK

Corrosion measurements in negative-grounded flat plate $\text{Li}/\text{SO}_2\text{Cl}_2$ cells show that although the rate of corrosion moderates in course of time, it is still at a relatively high level of 20 mpy after over three weeks of storage. This is corroborated by the complete consumption of thin lithium anodes in cells stored for a few days at temperatures 10°C above ambient. The corrosion rate of lithium exposed to electrolyte in sealed glass ampules is however quite low (2 mpy after one week). The cause of the high corrosion in the cell environment will be investigated in the next quarter.

The thickness of the LiCl film on lithium varies from 200 to 2000\AA . Thick films cause considerable voltage delay on the initiation of discharge of stored cells. The effect of additives on the thickness of the film will be studied with the aim of reducing the delay. Baseline cathode performance of 27 mAh/cm^2 with 0.5 mm thick Shawinigan Black/Teflon cathodes discharged at 10 mA/cm^2 current density, was established. The effect of electrolyte additives, especially bromide on cathode performance will be investigated.

The conductivity and density of $\text{LiAlCl}_4\text{-SOCl}_2$ electrolyte in the 0.5 to 2.0 M range and temperatures between ambient and 60°C were measured. These measurements will be extended to lower temperatures.

Prepared for: ERADCOM
Contract No.
Quarterly Progress Report

Gould Laboratories
Gould Document No. 827-001
May 10, 1982

DISTRIBUTION LIST

Defense Technical Info Ctr
ATTN: DTIC-TCA
Cameron Station (Bldg 5)
Alexandria, VA 22314 (12)

HQDA (DAMA-ARZ-D/Dr. F.D. Verderame)
Washington, DC 20310 (1)

Cdr. Naval Surface Weapons Ctr
White Oak Laboratory
ATTN: Library, Code WX-21
Silver Spring, MD 20910 (1)

Cdr, Harry Diamond Laboratories
ATTN: Library
2800 Powder Mill Road
Adelphi, MD 20783 (1)

Commandant, Marine Corps
HQ, US Marine Corps
ATTN: Code LMC, INTS (In Turn)
Washington, DC 20380 (1)

Director
US Material Sys Anal Actv
ATTN: DRXSY-T
Aberdeen Prov Grnd, MD 21005 (1)

Rome Air Development Center
ATTN: Documents Library (TSLD)
Griffiss AFB, NY 13441 (1)

Cdr, USA Signals Warfare Lab
ATTN: DELSW-OS
Vint Hill Farms Station
Warrenton, VA 22186 (1)

AFGL/SULL
S-29
HAFB, MA 01731 (1)

Commander
USA Mobility Eqp Res & Dev Cmd
ATTN: DRDME-R
Fort Belvoir, VA 22060 (1)

Prepared for: ERADCOM
Contract No.
Quarterly Progress Report

Gould Laboratories
Gould Document No. 827-001
May 10, 1982

Cdr, Harry Diamond Labs
ATTN: DELHD-CO,TD (In Turn)
2800 Powder Mill Road
Adelphi, MD 20783 (1)

Commander
US Army Electronics R&D Command
DELET-PR (S. Gilman)
Fort Monmouth, NJ 07703 (18)

Commander
US Army Electronics R&D Command
DELET-DT
Fort Monmouth, NJ 07703 (1)

NASA Scientific & Tech Info
Facility
Baltimore/Washington Intl Airpt
P.O. Box 8757, MD 21240 (1)

Commander
US Army Electronics R&D Command
DELET-DD
Fort Monmouth, NJ 07703 (1)

CMDR, MICOM
ATTN: DRCPM-HDE
Redstone Arsenal, AL 35809 (1)

Commander
US Army Electronics R&D Command
DELSL-L (Library)
Fort Monmouth, NJ 07703 (1)

Dr. H. Grady
Foote Mineral Company
Route 100
Exton, PA 19341 (1)

Commander
US Army Electronics R&D Command
DELSL-L-S (Stinfo)
Fort Monmouth, NJ 07703 (2)

Dr. D. Chuah
Honeywell, Inc.
104 Rock Road
Horsham, PA 19044 (1)

Prepared for: ERADCOM
Contract No.
Quarterly Progress Report

Gould Laboratories
Gould Document No. 827-001
May 10, 1982

Mr. Robert L. Higgins
Eagle-Picher Industries, Inc.
Electronics Division
P.O. Box 47
Joplin, Missouri 64801 (1)

Mr. Richard Pabst
GTE Sylvania, Inc.
77 A Street
Needham Heights, MA 02194 (1)

Attn: Technical Library
Yardney Electric Company
82 Mechanic Street
Pawcatuck, CT 06379 (1)

Dr. J.L. Hartman
General Motors Corp.
Research Laboratories
General Motors Technical Center
12 Mile and Mounds Road
Warren, MI 48090 (1)

Dr. A.N. Dey
Duracell International, Inc.
Northwest Industrial Park
Burlington, MA 01803 (1)

Union Carbide Corporation
Parma Research Center
P.O. Box 6116
Cleveland, OH 44101 (1)

Dr. R. Hamlen
Exxon Research & Engineering Co.
Corporate Research Laboratory
Linden, NJ 07036 (1)

J. Dalfonso
Duracell International, Inc.
S. Broadway
Tarrytown, NY 10591 (1)

Dr. E.C. Gay
Argonne National Laboratories
9700 South Cass
Argonne, IL 60439 (1)

Dr. L. Heredy
North American Rockwell Corp
Atomics International Division
Box 309
Canoga Park, CA 91304 (1)

Prepared for: ERADCOM
Contract No.
Quarterly Progress Report

Gould Laboratories
Gould Document No. 827-001
May 10, 1982

Dr. Stefan Mitoff
General Electric R&D Center
P.O. Box 8
Schenectady, NY 12301 (1)

Dr. Ronald McDonald
GTE Laboratories, Inc.
520 Winter Street
Waltham, MA 02154 (1)

Dr. J. Kennedy
University of California
Department of Science & Research
Santa Barbara, CA 93100 (1)

Dr. Eisenberg
Electrochimica
2485 Charleston Road
Mountain View, CA 94040 (1)

Mr. S. Charlip
Gulton Industries, Inc.
Metuchen, NJ 08840 (1)

Dr. H.P. Silverman
Energy Storage & Conversion Dept.
TRW Systems
One Space Park
Redondo Beach, CA 90278 (1)

Nehemiah Margalit
INCO Research & Development Center
Sterling Forest
Suffern, NY 10901 (1)

J. Marshall
Sanders Associates, Inc.
24 Simon Street
Mail Stop NSI-2208
Nashua, NH 03060 (1)

Mr. B.J. Bragg
Propulsion and Power Division
Mail Code EP5
NASA-Johnson Space Center
Houston, Texas 77058 (1)

Stuart Chodosh
Power Conversion, Inc.
70 MacQuesten Pkwy
Mount Vernon, NY 10550 (1)

Prepared for: ERADCOM
Contract No.
Quarterly Progress Report

Gould Laboratories
Gould Document No. 827-001
May 10, 1982

Portfolio Manager
Hooker Chemicals & Plastics Corp
M.P.O. Box 8
Niagara Falls, NY 14302 (1)

Mr. J.R. Moden
Energy Conversion Branch Code 3642
Naval Underwater Systems Center
Newport Laboratory
Newport, RI 02840 (1)

Dr. Leonard Nanis
G207
S.R.I.
Menlo Park, CA 94025 (1)

Dr. Stuart Fordyce
NASA Lewis Research Center
Mail Stop 6-1
21000 Brookpark Road
Cleveland, OH 44135 (1)

Dr. J.J. Auburn, Rm 1A-317
Bell Laboratories
600 Mountain Avenue
Murray Hill, NJ 07974 (1)

Mr. Joe McCartney
Naval Undersea Center
Code 608
San Diego, CA 92132 (1)

Mr. Harvey Frank
Mail Stop 198-220
Jet Propulsion Laboratory
4800 Oak Grove Drive
Pasadena, CA 91103 (1)

S.B. Brummer
EIC, Inc.
Newton, MA 02158 (1)

Dr. D. Ernst
Naval Surface Weapons Center
White Oak Laboratory,
Code R-33 (M/S A026)
Silver Spring, MD 20910 (1)

Douglas Glader
Altus Corp
440 Page Mill Road
Palo Alto, CA 94306 (1)

Prepared for: ERADCOM
Contract No.
Quarterly Progress Report

Gould Laboratories
Gould Document No. 827-001
May 10, 1982

J. Bene
MS 488
NASA Langley Research Center
Hampton, VA 23665 (1)

Dr. Frank Bis
Naval Surface Weapons Center
White Oak Laboratory, Code R-33
Silver Spring, MD 20910 (1)

Mr. Eddie T. Seo
Research and Development Division
The Gates Rubber Co.
999 S. Broadway
Denver, CO 80217 (1)

Dr. Jerry J. Smith
ONR Chemical Program
Arlington, VA 22217 (1)

Mr. Sidney Gross
Mail Stop 8C-62
Boeing Aerospace Company
P.O. Box 3999
Seattle, WA 98124 (1)

Mr. Lou Adams
Saft Corporation of America
711-A Industrial Blvd.
P.O. Box 1284
Valdosta, GA 31601 (1)

Dr. H.V. Venkatesetty
Honeywell Technology Center
10701 Lyndale Avenue, South
Bloomington, MN 55420 (1)

Dr. C. Liang
Electrochem Industries (E·I) Inc.
9990 Wehrle Drive
Clarence, NY 14031 (1)

Mr. Aiji Uchiyama
Jet Propulsion Laboratory-M.S. 198-220
4800 Oak Grove Drive
Pasadena, CA 91103 (1)

Dr. C. Schlaiker
GTE Laboratories Incorporated
40 Sylvan Road
Waltham, MA 02254 (1)

Prepared for: ERADCOM
Contract No.
Quarterly Progress Report

Gould Laboratories
Gould Document No. 827-001
May 10, 1982

Dr. Harvey N. Seiger
Harvey N. Seiger Associates
8 Beacon Hill Drive
Waterford, CT 06385

(1)

DATE
FILME
8-8