

AD A116416

13

UNCLASSIFIED

DESIGN AND DEVELOPMENT OF A 5,000 BARREL
COLLAPSIBLE FABRIC PETROLEUM
FUEL TANK ASSEMBLY

PHASE II
FINAL REPORT FOR PERIOD
31 JANUARY THROUGH 10 JULY 1981

BY

CURT R. GRAHAM
GEORGE P. DURNEY

U. S. ARMY MOBILITY EQUIPMENT
RESEARCH AND DEVELOPMENT COMMAND
FORT BELVOIR, VIRGINIA

DTIC
SELECTED
JUL 2 1982
S D H

**ILC
DOVER**



DTIC FILE COPY

PREPARED UNDER CONTRACT DAAK70-79-C-0211
ILC Dover
P. O. Box 266
Frederica, Delaware 19946

APPROVED FOR PUBLIC RELEASE DISTRIBUTION UNLIMITED

UNCLASSIFIED

82 07 02 062

SECURITY CLASSIFICATION OF THIS PAGE (When Data Entered)

| REPORT DOCUMENTATION PAGE | | READ INSTRUCTIONS BEFORE COMPLETING FORM |
|---|-----------------------|---|
| 1. REPORT NUMBER | 2. GOVT ACCESSION NO. | 3. RECIPIENT'S CATALOG NUMBER |
| 4. TITLE (and Subtitle) Design and Development of a 5,000 Barrel Collapsible Fabric Petroleum Fuel Tank Assembly | | 5. TYPE OF REPORT & PERIOD COVERED Phase II Final Report 31 Jan. through 10 July 1981 |
| 7. AUTHOR(s) Curt R. Graham George P. Durney | | 6. PERFORMING ORG. REPORT NUMBER |
| 9. PERFORMING ORGANIZATION NAME AND ADDRESS ILC Dover/Inflatable Products Box 266 Frederica, DE 19946 | | 8. CONTRACT OR GRANT NUMBER(s) DAAK70-79-C-0211 |
| 11. CONTROLLING OFFICE NAME AND ADDRESS U.S. Army Mobility Equipment Research & Development Command, Fort Belvoir, VA 22060 | | 10. PROGRAM ELEMENT, PROJECT, TASK AREA & WORK UNIT NUMBERS |
| 14. MONITORING AGENCY NAME & ADDRESS (if different from Controlling Office) | | 12. REPORT DATE 21 August 1981 |
| | | 13. NUMBER OF PAGES |
| | | 15. SECURITY CLASS. (of this report) Unclassified |
| | | 15a. DECLASSIFICATION, DOWNGRADING SCHEDULE |
| 16. DISTRIBUTION STATEMENT (of this Report) Distribution Unlimited | | |
| 17. DISTRIBUTION STATEMENT (of the abstract entered in Block 20, if different from Report) | | |
| 18. SUPPLEMENTARY NOTES | | |
| 19. KEY WORDS (Continue on reverse side if necessary and identify by block number) 5000 Barrel Tank Bulk Fuel Storage Elastomeric Coated Fabric | | |
| 20. ABSTRACT (Continue on reverse side if necessary and identify by block number) ILC Dover, after developing two leading candidate coated fabrics for use on the 5,000 barrel collapsible fabric fuel tank, designed and fabricated that fuel tank for testing in the tropics. The tank was built from the polyurethane coated Kevlar fabric. ILC designed high stress compression rings and a wick-proof suction stub for use on the tank. Commercial products were found to be acceptable for all other hardware. | | |

SUMMARY

The purpose of Phase II of this program was to fabricate a prototype 5,000 barrel collapsible fabric fuel tank from one of the two leading candidate coated fabrics developed in Phase I. ILC recommended that the tank be fabricated from the Hooker CO-AX-5139 polymer coated on the Kevlar base fabric.

The compression rings, handle, chafing patches, suction stub, and other designs developed during Phase I, along with commercially available hardware, were incorporated into the fabricated tank. ILC conducted seam testing to determine the optimum seam design. The seam selected for most of the unit was a heat sealed, butted and taped seam using a base fabric inner and outer tape. The closing seams for the fuel tank were cemented. A contoured corner was also used for this tank based on computer stress analysis.

The adhesive selected for closing seams bonding handles, load patches, and for field repair is a solvent MEK based adhesive (Bostik 7376). The adhesive chosen to bond the urethane to metal is Versilok 201.

The prototype 5,000 barrel tank was shipped in July, 1981 for Army testing in tropic conditions. ILC recommends that upon successful completion of tropic testing, the tank be used in an operational exercise which would simulate the original scenario for which this tank was to be used.

DTIC
COPY
INSPECTED
2

| Accession For | |
|--------------------|-------------------------------------|
| NTIS GRA&I | <input checked="" type="checkbox"/> |
| DTIC TAB | <input type="checkbox"/> |
| Unannounced | <input type="checkbox"/> |
| Justification | |
| By _____ | |
| Distribution | |
| Availability Codes | |
| Dist _____ | |

A

PREFACE

This report delineates work done under Phase II of Contract DAAK70-79-C-0211 for the U. S. Army Mobility Equipment Research and Development Command, on coated fabrics hardware and assembly techniques for design and fabrication of a lightweight 5,000 barrel (210,000 gallon) fuel storage tank.

TABLE OF CONTENTS

| <u>SECTION</u> | <u>TITLE</u> | <u>PAGE</u> |
|----------------|----------------------------------|-------------|
| | TITLE PAGE..... | |
| | REPORT DOCUMENTATION PAGE..... | |
| | SUMMARY..... | i |
| | PREFACE..... | ii |
| | TABLE OF CONTENTS..... | iii |
| | LIST OF FIGURES..... | iv |
| | LIST OF TABLES..... | v |
| | LIST OF APPENDICES..... | vi |
| 1.0 | INTRODUCTION..... | 1 |
| 2.0 | TANK CONSTRUCTION PROCEDURE..... | 2 |
| 2.1 | Seams..... | 2 |
| 2.2 | Subassemblies..... | 3 |
| 2.2.1 | Handles..... | 3 |
| 2.2.2 | Label..... | 3 |
| 2.3 | Tank Construction..... | 3 |
| 2.4 | Adhesives..... | 5 |
| 2.5 | Hardware..... | 10 |
| 2.6 | Emergency Repair Kit..... | 10 |
| 2.7 | Air Leakage Test..... | 10 |
| 3.0 | CONCLUSIONS..... | 18 |
| 4.0 | RECOMMENDATIONS..... | 19 |
| 5.0 | TEST DATA OF TANK..... | 20 |

LIST OF FIGURES

| | LIST OF FIGURES | PAGE |
|-----------|-------------------------------------|------|
| Figure 1 | Typical Heat Sealed Seam | 2 |
| Figure 2 | Handle Assembly | 4 |
| Figure 3 | Handle Webbing Assembly | 4 |
| Figure 4 | Label, 5,000 Barrel Fuel Tank | 6 |
| Figure 5 | End Cap Cut Line | 7 |
| Figure 6 | End Cap Closure Seam | 7 |
| Figure 7 | First Center Quarter Panel Assembly | 8 |
| Figure 8 | Typical Adhesive Seam | 8 |
| Figure 9 | Tank Half Body Assembly | 8 |
| Figure 10 | Tank Body Assembly | 9 |
| Figure 11 | Compression Fitting Cross Section | 9 |
| Figure 12 | Filler Discharge Assembly | 11 |
| Figure 13 | Vent Fitting Assembly | 12 |
| Figure 14 | Drain Fitting Assembly | 13 |
| Figure 15 | 5,000 Barrel Fuel Tank Assembly | 14 |

LIST OF TABLES

PAGE

| | | |
|---------|--|----|
| TABLE 1 | Hardware Parts List | 15 |
| 2 | Characteristics of Fabric | 21 |
| 3 | Characteristic of Cured Elastomeric Coating Compounds | 22 |
| 4 | Characteristics of Coated Fabric | 24 |
| 5 | Characteristics of Bonded Fittings | 26 |
| 6 | Characteristics of Seams | 27 |

| | LIST OF APPENDICES | PAGE |
|--------------|-----------------------|------|
| APPENDIX "A" | LIST OF MANUFACTURERS | 28 |

1.0

INTRODUCTION

The optimum size for a bulk fuel storage tank was determined to be 5,000 barrels in Phase I of the project using operational cost and ease of manufacturing analyses. Only commercial materials were considered in materials investigation. The three base fabrics that were evaluated are polyester, nylon and kevlar. The polymers that were evaluated area polyester polyurethane and polyether polyurethane. The sixteen laboratory coated samples composed of varying polymers and base fabrics were fabricated and tested. As a result, two leading condidates; Hooker CO-AX-5139 on 8.5 oz. kevlar and Hooker CO-AX-5139 on 13 oz. nylon, were selected for production machinery. Upon further evaluation, it was determined that the optimum construction was the Hooker Rucothane CO-AX-5139 polyester coated on 8.5 oz. kevlar.

ILC designed and fabricated high stress compression fittings and validated its bonding techniques to aluminum fittings. A leak proof suction stub was also designed. The test results of the 5,000 barrel tank are in Secion 5. This report describes Phase II of the project which involved the fabrication and testing of a 5,000 barrel prototype collapsible fuel tank.

2.0 TANK CONSTRUCTION PROCEDURE DISCUSSION

2.1 SEAMS

One type of seam used on the 5,000 barrel tank is shown in Figure 1. The width of the tape was determined by the overlap required to produce the tensile strength of the base fabric. During fabrication of the tank, a minimum of three samples were made and tested to insure that the seam met specifications. The samples were taken at the beginning of the workday, before lunch, and one at day's end. Additionally, if any settings were touched during the course of production, an additional sample was made and tested.

1. The dielectric sealing process was performed in accordance with paragraph 3.5.1.1.1 of ILC Technical Proposal (BPN 79-624) to solicitation No. DAAK70-79-Q-1809. The seam was made in two passes. The first pass installed the outside tape and the second pass applies the inside tape.

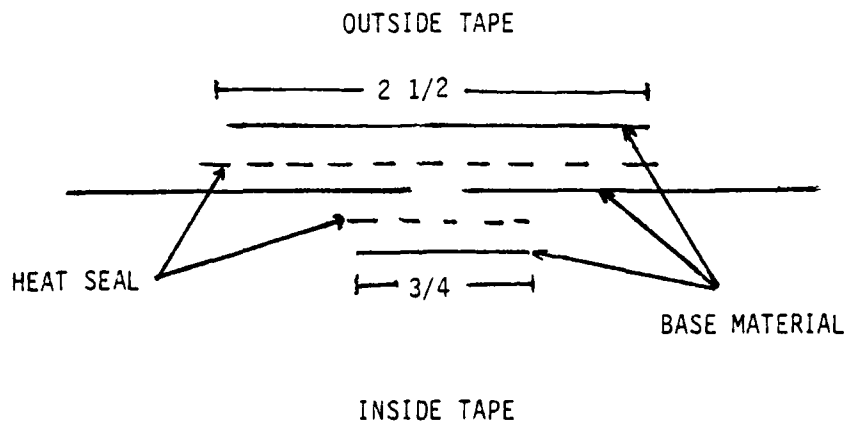

FIGURE 1 TYPICAL HEAT SEALED SEAM

A second type seam used on the 5000 barrel tank is an adhesive seam which is shown in Figure 8. A description of cemented seam construction is given in section 2.4.

2.2 SUBASSEMBLIES

2.2.1 Handle

The handle assembly was fabricated as shown in Figure 2 using the Bostik 7376 adhesive, polyester webbing, size FF thread, and tank material. The first step in assembly is to sew two 24-inch lengths of 6,000 pound tensile polyester webbing together using size FF polyester thread using a box stitch (5-6 stitches per inch). The box should end 3 inches from either end (see Figure 3) and an extra row of stitches should be along each end of the box. The ends of the webbing are then inserted through the outer patch made from the tank material. The two circular inner patches are then cemented over the slits insuring the two webbing ends are at a 180° angle to each other. A box stitch is then sewn in through the large patch, the webbing and the inner patch. An extra row of stitches is sewn along the side of the box facing the slit. At final assembly, the handle is then cemented to the tank.

2.2.2 Label

The label is made by impressing a 20 mil piece of Tuftane 310 with an offset printing plate which is configured as shown in Figure 4. To make the letters stand out, a piece of nylon cloth is placed behind the Tuftane at the time of impression. The letters were then colored in black ink. Once the label has been made and cemented with Bostik 7376 to the tank at final assembly, the pertinent information is stamped in black ink on the tank.

2.3 TANK CONSTRUCTION

The first step in construction of the 5,000 barrel tank is initiated by forming end cap subassemblies. This is done by taking three panels, each panel 54 inches wide by 95.244 feet long, and sealing them together lengthwise using the seam shown in Figure 1. Templates are then laid over the ends of the fabric to form the cut marks as shown in Figure 5. End A should be heat sealed to End B and End C heat sealed to End D with the wider seam on the outside as shown in Figure 6.

Once both end cap subassemblies are formed, 20 panels are be cut, 54 inches wide by 95.244 feet long. Four quarter panel subassemblies of 5 panels each are heat sealed together as shown in Figure 6, Section B-B with the standard heat seal seam. The access door, vent, and drain fitting should be located,

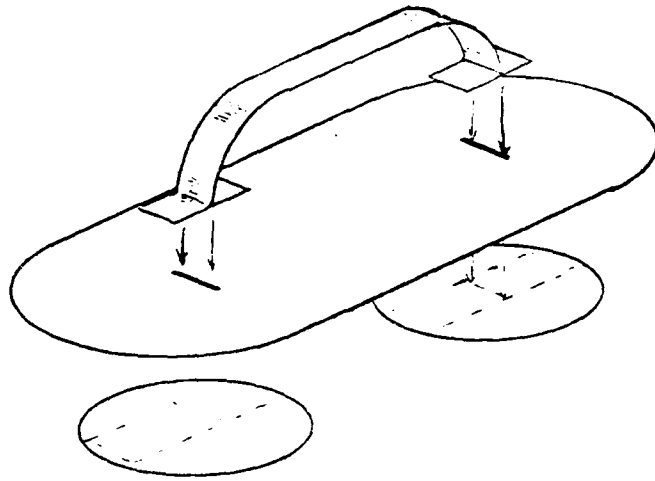

FIGURE 2 HANDLE ASSEMBLY

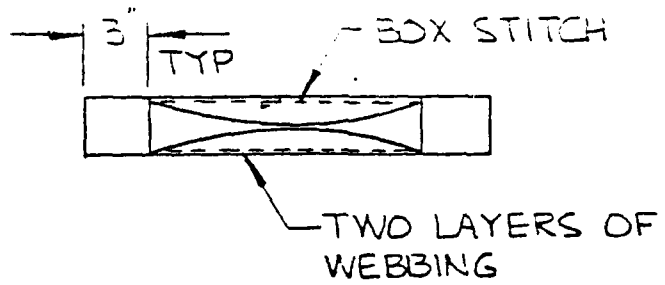

FIGURE 3 HANDLE WEBBING ASSEMBLY

marked, chafing patches and fitting reinforcements cemented to the appropriate quarter panel using Bostik 7376. The next step is to cement one of the quarter panels to the end cap, starting at the top center (Figure 7) using the seam shown in Figure 8 and Bostik 7376. The second center quarter panel should then be joined to the other side of the end cap, using the adhesive seam as shown in Figure 9 to form a tank half. The same procedure should be used to form the other tank half. The final tank assembly is achieved by joining the two halves together using the adhesive seam in Figure 8. At all locations where two seams meet, a 3-inch diameter reinforcement patch is cemented to the tank with Bostik 7376. The twenty-two handles and the label are then cemented to the tank with Bostik 7376. The final attachment to the tank assembly (using Versilok 201) should be the oval and round compression fittings whose cross section is detailed in Figure 11.

2.4

ADHESIVES

One adhesive each was chosen for bonding urethane-to-urethane and urethane-to-aluminum. The adhesive chosen for bonding urethane-to-urethane was the Bostik 7376. The reason was its superior performance after 14 days in immersion at 160°F in distilled water and reference Fuel D. Of the twelve adhesives that were tried, Bostik 7376 with Boscodur Number 4 was the only adhesive that would take the coating off the base fabric after 42-day immersion. The adhesive is a urethane solvent based adhesive in which the solvent is MEK (methyl-ethyl ketone). The fumes of the solvent are toxic and flammable and extreme care must be taken when using the adhesive. The adhesive was to be applied as follows:

1. Scuff the area to be abraided with emery paper.
2. Apply a single coat of adhesive (Bostik 7376 and Boscodur Number 4 pre-mixed) with a brush to each piece of material and allow to dry.
3. Apply a second coat of Bostik 7376 as in Step 2 above and allow to dry.
4. Activate the adhesive by dabbing a cheese cloth in MEK and briefly wiping the cemented area.
5. Immediately after activating the adhesive with MEK, put the two pieces of material together and, using a roller, roll the affected material to insure good bond and eliminate air bubbles.

TANK, FABRIC, COLLAPSIBLE
EXPERIMENTAL, 5000 BARRELS

NSN:

SERIAL NO:

MFR: ILC DOVER, FREDERICA, DE.

MFG. DATE:

WEIGHT EMPTY:

CONTRACT NO: DAAK70-79-C-0211

$5\frac{1}{2}$ REF

$12\frac{3}{4}$ REF

FIGURE 4, LABEL 5,000 BARREL FUEL TANK

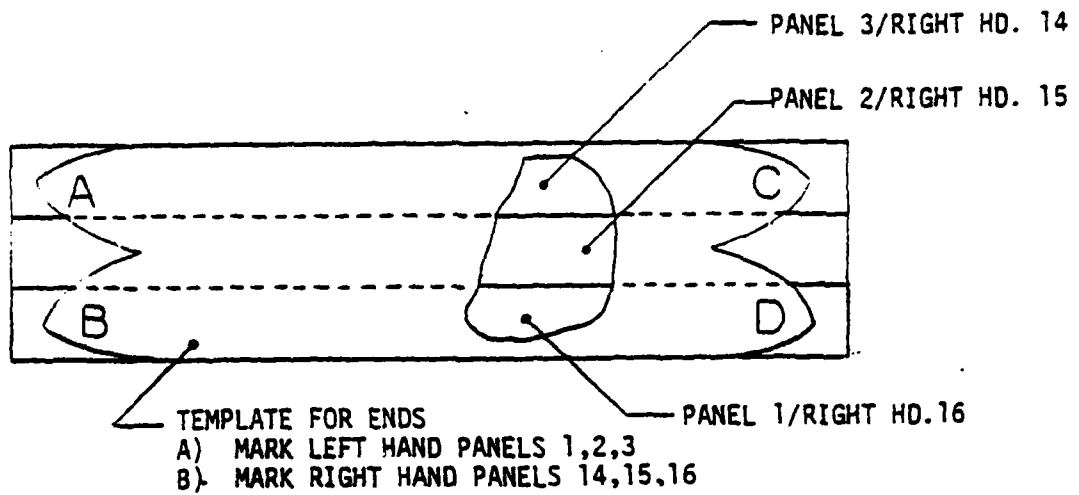

FIGURE 5 END CAP CUT LINES

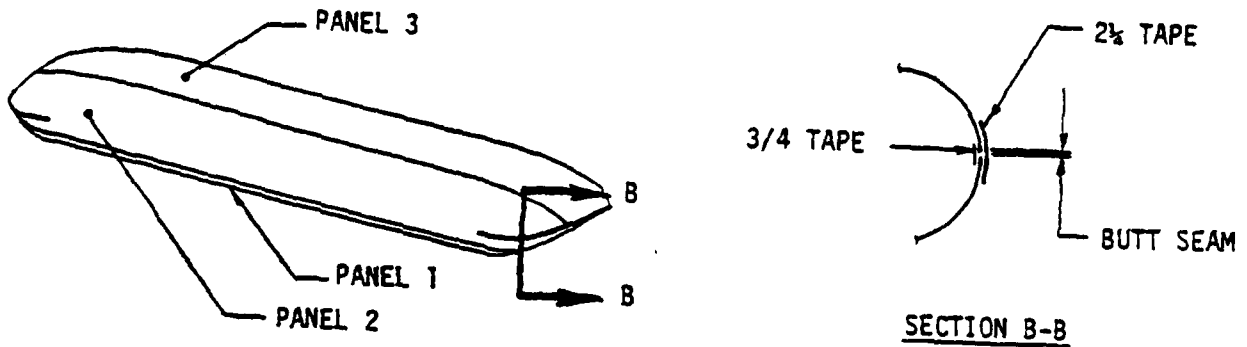

FIGURE 6 END CAP CLOSE SEAM

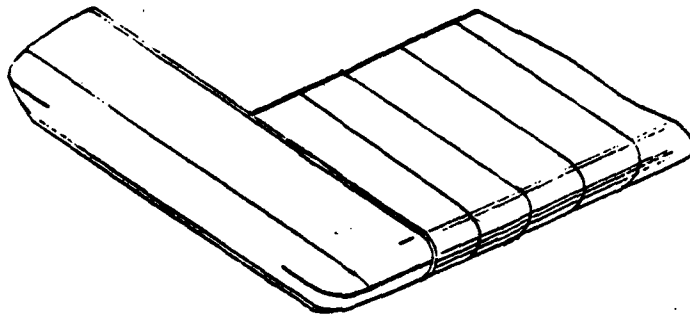

FIGURE 7 FIRST CENTER QUARTER PANEL ASSEMBLY

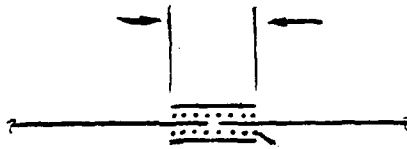

FIGURE 8 TYPICAL ADHESIVE SEAM

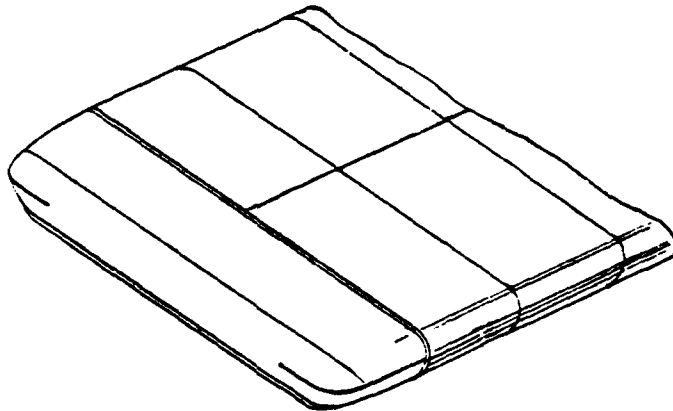

FIGURE 9 TANK HALF BODY ASSEMBLY

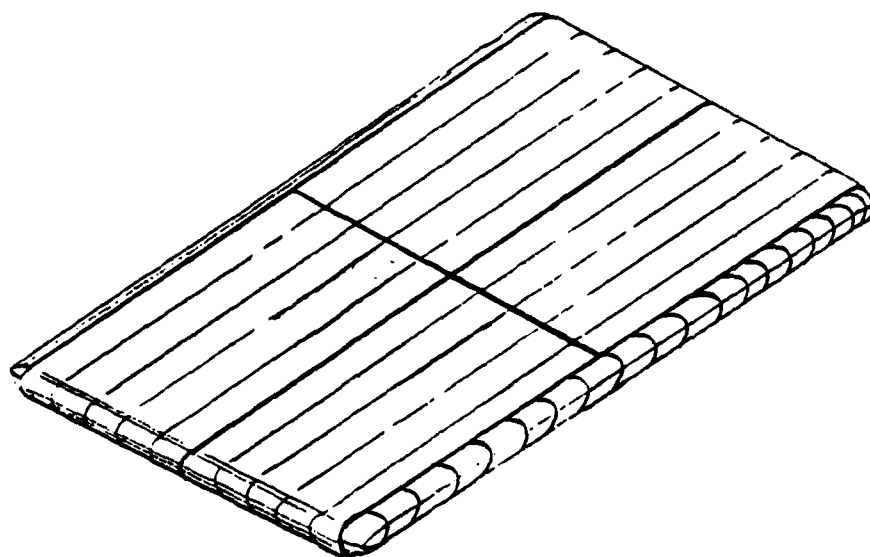

FIGURE 10 TANK BODY ASSEMBLY

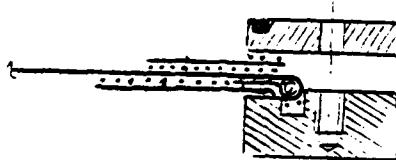

FIGURE 11 COMPRESSION FITTING CROSS SECTION

The adhesive chosen for bonding urethane to aluminum is the Versilok #201 with Accelerator #4 (Hughson Chemicals Company). Neither of these adhesives are toxic, but the Accelerator #4 is mildly corrosive and care should be taken in its storage. This adhesive should be applied as follows:

1. Dry hone the area to be cemented on the metal fitting and scuff the coated fabric area with emery paper.
2. Apply one coat of accelerator #4 on the aluminum piece to be bonded.
3. Apply one coat of Versilok #201 to urethane material with a brush.
4. Immediately join urethane material to aluminum fixture and clamp them either by using vise grips or C-clamps.
5. Leave clamped for approximately one hour.

Both adhesives should be applied in the 50°F to 80°F temperature range and no greater than 60% humidity.

2.5 HARDWARE

The hardware provided with the tank is listed in Table 1. Figures 12, 13 and 14 show three fitting subassemblies. Figure 15 shows each of the fitting subassemblies' location on the tank.

2.6 EMERGENCY REPAIR KIT

The complete listing of the repair kit components is shown in Table I

2.7 AIR LEAKAGE TEST

An air leakage test was done in accordance with Paragraph 4.6.2 of MIL-T-82123A (MC) and the 5,000 barrel tank passed the test.

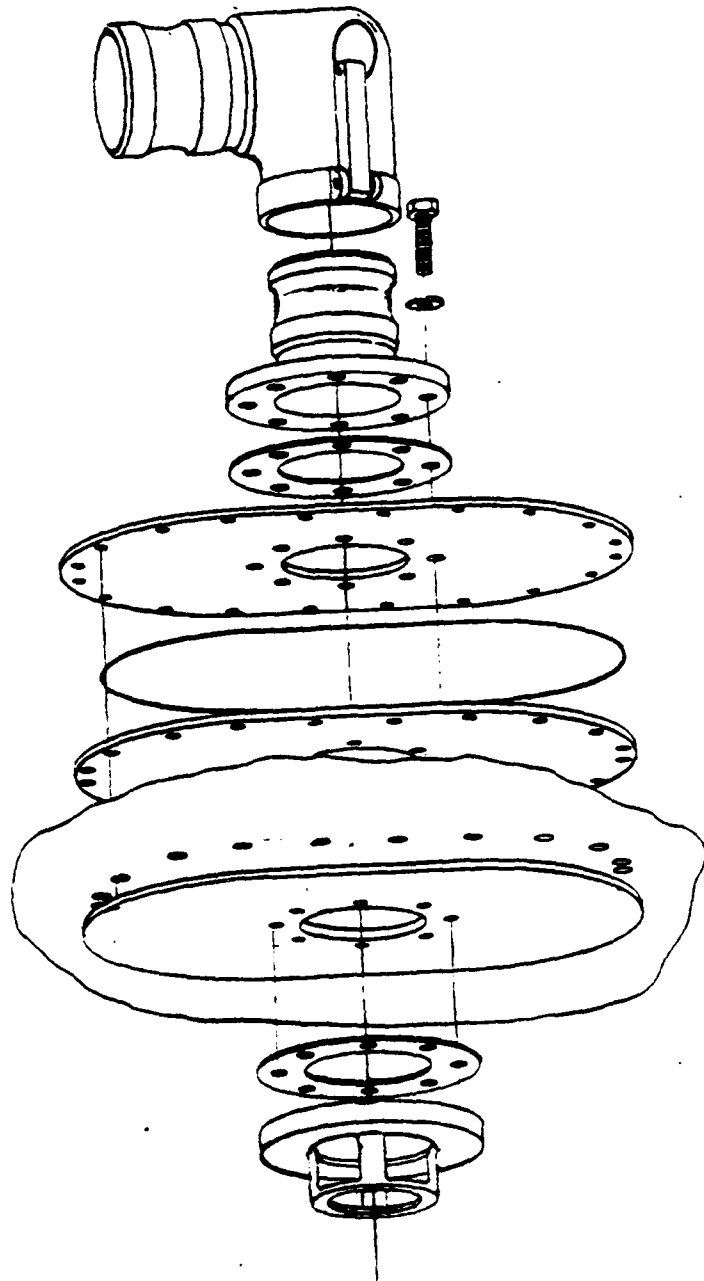

FIGURE 12 FILLER DISCHARGE ASSEMBLY

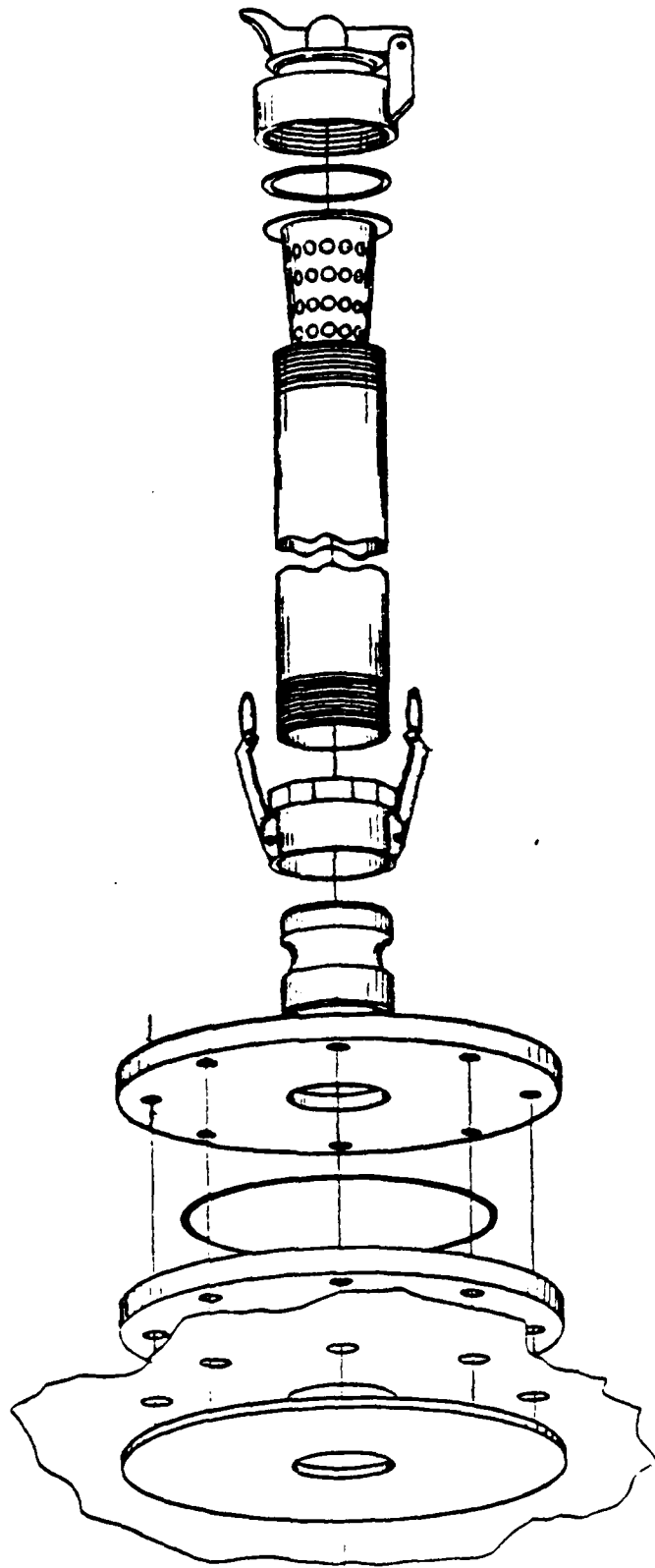

FIGURE 13 VENT FITTING ASSEMBLY

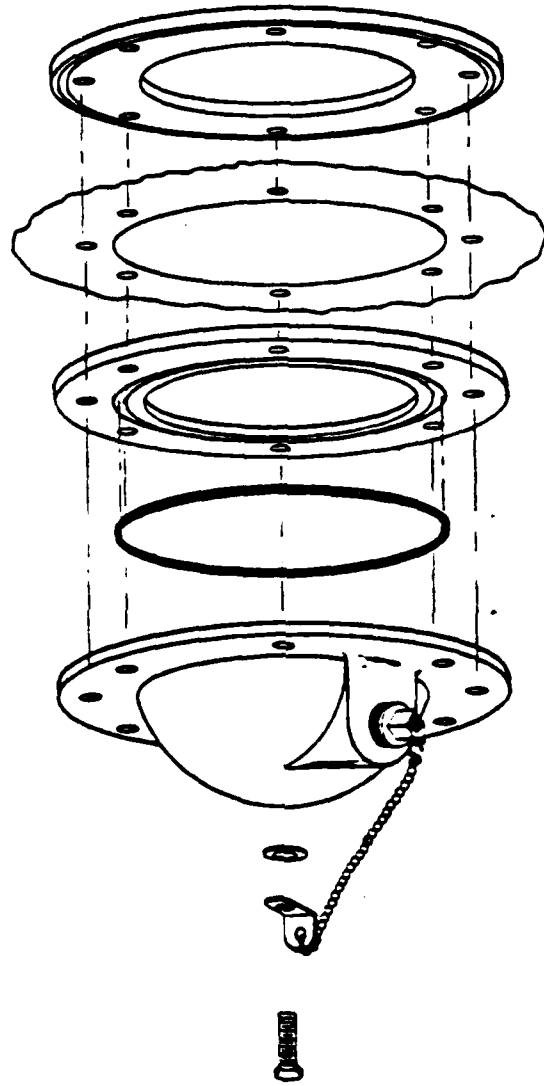

FIGURE 14 DRAIN FITTING ASSEMBLY

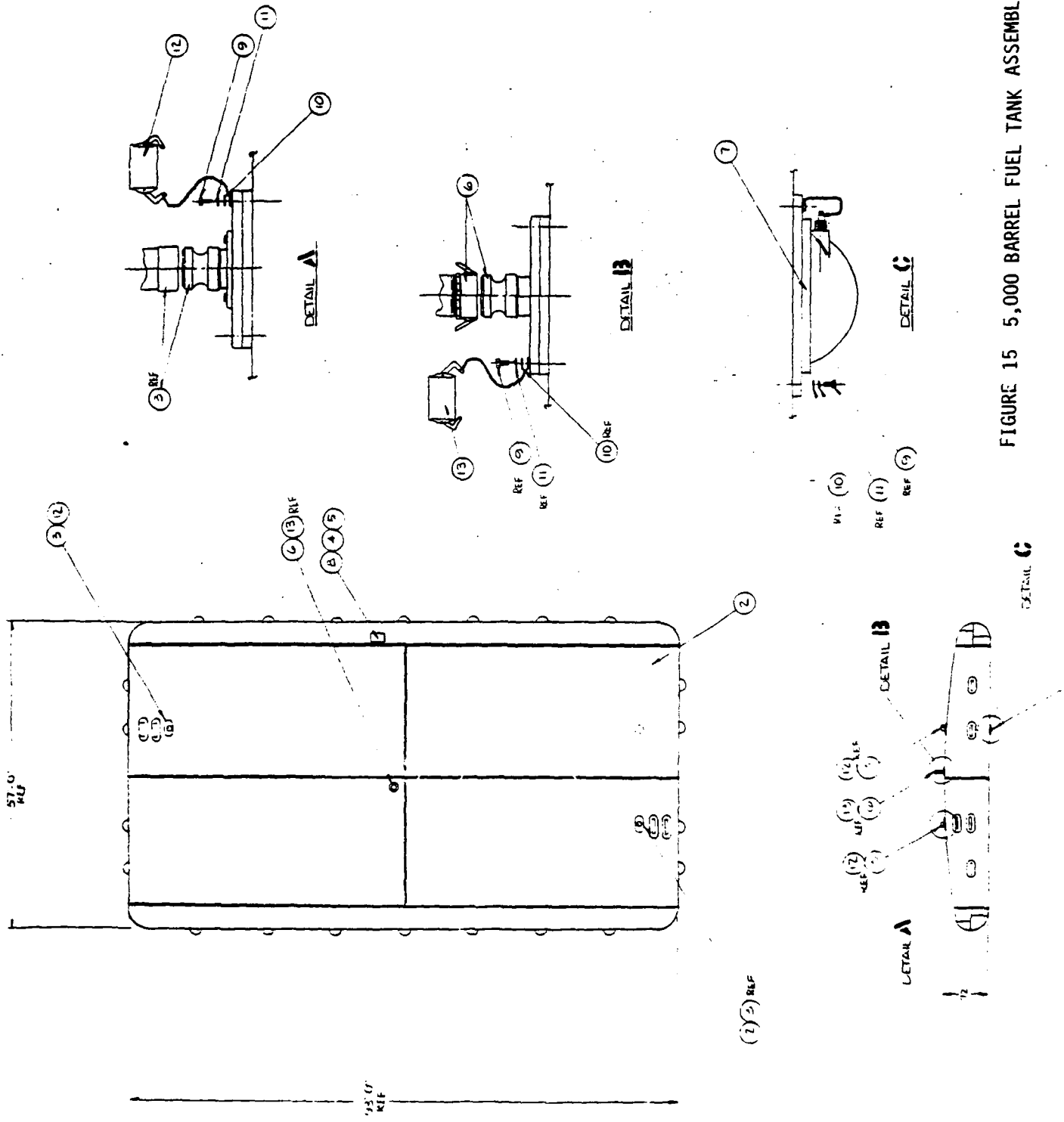

FIGURE 15 5,000 BARREL FUEL TANK ASSEMBLY

TABLE I HARDWARE PARTS LIST

| <u>PART NUMBER</u> | <u>MFG. PART NUMBER</u> | <u>MANUFACTURER</u> |
|-------------------------------------|-------------------------|---------------------|
| <u>I. FILLER/DISCHARGE ASSEMBLY</u> | | |
| Oval "O" Ring, High Stress | 0061-24276-01 | ILC |
| Oval Nut Ring, High Stress | 0061-24275-01 | ILC |
| "O" Ring | M59021-383 | DBR Disbributing |
| Oval Closure Plate | CP24-0062-02 | Cast Rite |
| Gasket Cork | CP61-0024 | SAS Gasket Supply |
| Suction Stub. | 0061-24170-01 | ILC |
| Coupling Half, Flanged | MS27023-19 | Evertite |
| Screw Cap, Hex Head | MS90726-63 | Century Fastener |
| Washer, Lock, Stl. Cad. Pltd. | MS35338-46 | Century Fastener |
| Washer, Flat Round | MS27183-B | Century Fastener |
| Elbow, Female to Male, w/Gasket | CP24-0063 | Evertite |
| Dust Cap with Chain | MS27028-19 | Evertite |
| Screw Cap, Hex Head | MS90725-63 | Century Fastener |
| <u>II. DRAIN FITTING ASSEMBLY</u> | | |
| Nut Ring, Round, High Stress | 0061-24277-01 | ILC |
| Round "O" Ring Plates, High Stress | 0061-24278-01 | ILC |
| Drain Fitting | CP24-0020-02 | Cast Rite |
| Tank Chain | 0056-24051-01 | ILC |
| Tank Screw | 0056-84052-01 | ILC |
| Plug and Chain | 0056-24043-01 | ILC |
| Screw Cap, Hex Head | MS90725-63 | Century Fastener |
| Washer, Flat Round | MS27183-13 | Century Fastener |
| Washer Lock | MS35338-46 | Century Fastener |
| "O" Ring | MS29513-250 | DBR Distributing |

Table I Hardware Parts List - Cont'd

| <u>PART NUMBER</u> | <u>MFG. PART NUMBER</u> | <u>MANUFACTURER</u> |
|-----------------------------------|-------------------------|---------------------|
| <u>III. VENT FITTING ASSEMBLY</u> | | |
| Nut Ring, Round, High Stress | 0061-24277-01 | ILC |
| Round "0" Ring, High Stress | 0061-24278-01 | ILC |
| Coupling Half, Male, Flanged | 0056-24064-02 | ILC |
| Coupling Half, Female, Threaded | MS27024-11 | Evertite |
| Vent Pipe | 0056-24050-01 | Euston Steel |
| Relief Cap with Flame Arrestor | CP20-0204 | Protecto-Seal |
| Dust Cap with Chain | MS27028-11 | Evertite |
| Screw Cap, Hex Head | MS90725-63 | Century Fastener |
| Washer, Flat Round | MS27183-13 | Century Fastener |
| Washer Lock | MS35338-46 | Century Fastener |
| "0" Rings | MS29513-250 | DBR Distributing |
| <u>IV. ACCESSORIES</u> | | |
| 10-Foot Hose, 6 Feet | CP24-0061 | Elastofab |
| Ground Cloth, Polyethylene | CP92-0037 | Read Plastics |
| 1/2-Inch Rising Stem Gate Valve | CP24-0018 | Speakman |
| 6-Inch Hanged Gate Valve | CP24-0059 | Speakman |
| 3/4-Inch Hose, 8 Feet | CP24-0015 | Elastofab |
| 6-Inch FL A Adaptor | CP20-0300 | Evertite |
| 6-Inch FL B Adaptor | CP20-0301 | Evertite |
| Washer, Flat 3/4-Inch | MS27183-23 | Century Fastener |
| 3/4-Inch "D" Coupling | CP20-0237 | Evertite |
| Btd, 3/4" x 2-1/2" | MS90725-192 | Century Fastener |
| Nut, 3/4-Inch | MS51967-23 | Century Fastener |

Table I Hardware Parts List - Cont'd

| <u>PART NUMBER</u> | <u>MFG. PART NUMBER</u> | <u>MANUFACTURER</u> |
|----------------------------------|-------------------------|---------------------|
| V. <u>EMERGENCY REPAIR ITEMS</u> | | |
| Sealing Clamp, 3" | NSN5430-00-766-8229 | PM Manufacturing |
| Sealing Clamp, 5" | NSN5430-00-766-8230 | PM Manufacturing |
| Sealing Clamp, 7.5" | NSN5430-00-768-0741 | PM Manufacturing |
| Plug, Tapered, Wood, 5" | CP20-0205 | Halco |
| Plug, Tapered, Wood, 3" | CP20-0206 | Halco |
| Bostik 7376 | CP30-0050 | Bostik |
| Boscodur No. 4 | CP30-0051 | Bostik |
| Versilok 201 | CP30-0037 | Hughson Chemical |
| Accelerator No. 4 | CP30-0038 | Hughson Chemical |
| Edgelock | CP30-0049 | Reeves Brothers |
| Patch Material | ST12P1205-02 | Reeves Brothers |
| Roller, Lot 003 | CP20-0284 | Robbins |
| Acid Brushes, Lot 008 | CP20-0002 | Fisher Scientific |
| MEK, Lot 18 | ST72K448-01 | Fisher Scientific |
| Cheese Cloth, Lot 019 | CP10-0017 | ILC |

3.0

CONCLUSIONS

The objective of Phase II of contract DAAK70-79-C-0211 was to answer two major questions. First, can the 5,000 barrel fuel tank, with its contoured corners, enormous size and specialized fittings, be manufactured by ILC Dover? Also, will the coated Kevlar fabric tank, with its comparatively lighter weight, withstand repeated field handling?

ILC successfully produced the 5,000 barrel tank with all the aforementioned features. In fact, ILC feels that in a procurement scenario, it could produce the tank with either the coated nylon or coated Kevlar fabric.

It is too premature, with existing data, to answer the second question. The laboratory tests conducted in Phase I indicated that the coated Kevlar material would withstand repeated hard folds encountered during normal field operations. It would then seem likely that, barring abnormal or abusive treatment during shipping, the 5,000 barrel tank should perform well in the field.

4.0

RECOMMENDATIONS

ILC recommends that the 5,000 barrel fuel tank be tested in the tropics to determine its performance in a field environment. ILC also recommends that the polyurethane coated Kevlar be evaluated for its respective ease of handling, durability, deployability and maintainability. ILC also recommends that the performance of redesigned suction stub be evaluated by the Army. If the design proves beneficial by use in the field, standardization of all suction stubs should conform to this design.

ILC finally recommends that, after successful testing in the tropics, the 5,000 barrel tank actually be used in an operational exercise to simulate the actual scenario for which the tank is intended.

5.0 TEST RESULTS

5.1 The majority of material testing for the 5,000 barrel tank was conducted during Phase I of the program. The results of these tests were presented in the Phase I program report. Additional material tests were conducted on the production tank material and seam samples. The data resulting from these tests are presented in Table 1 and 2 respectively. In addition, the tank was subjected to a leakage test using a soap solution to detect leaks. This test was successfully completed prior to shipping the tank.

TABLE 2 - CHARACTERISTICS OF FABRIC

| PROPERTY | REQUIREMENTS | TEST METHOD OF FED. STD. NO. 191 | ACTUAL |
|------------------------------------|--------------|-------------------------------------|----------------------------|
| Thread count, warp and fill | Record | 5050 | 32 x 32 |
| Weave | Record | Visual | Plain |
| Weight | Record | 5041 | 8.5 oz. |
| Thickness | Record | 5030.2 <u>1/</u> | 18 Mils |
| Tearing strength warp and fill | Record | 5134 | 230 lbs/in 235 lbs/in |
| Breaking strength warp and fill | Record | 5104 <u>2/</u> | 1127 lbs/in 1247 lbs/in |

FOOTNOTES:

- 1/ The edges of the tear-test specimen shall be coated by dipping into or brushes with an adhesive that will preclude yarn slipping while under test.
- 2/ Alternate corex D filters removed. Specimens shall be revealed for Method 5104 after accelerated weathering.
- 3/ Edges of specimens for Breaking Strength Test shall be coated by dipping into or brushing with an adhesive that will preclude yarn slipping under test. Only those parts that are to be held in the clamps during test will be so treated.

TABLE 3 - CHARACTERISTICS OF CURED ELASTOMERIC COATING COMPOUNDS

| PROPERTY | REQUIREMENT | TEST PARAGRAPH OR TEST METHOD OF FED. TEST METHOD STD. 601 | ACTUAL |
|---|----------------|--|-------------------------|
| Initial | | | |
| Tensile strength, psi | Record | 4111 | 4072 PSI |
| Stress at 200% elongation psi | Record | 4131 | 2256 PSI |
| Ultimate elongation, % | Record | 4121 | 378 |
| After immersion in distilled water, (ph of 7.0 ± 0.2) at 160°F ± 2°F for 14 days. | | | |
| Volume change % | Record | 6211 | 11% |
| Initial tensile strength retained (1) | | | |
| a. Interior compounds & barrier, (3) % (min) | 60% or 900 PSI | 6111 (para. 4.8.1 of Method 6111 applies) | 814 PSI or 54% of Spec. |
| b. Exterior top compounds, (4) % (min) | 60% or 900 PSI | | |
| c. Exterior bottom compounds, (4) % (min) | 50% or 750 PSI | | |
| After immersion in ASTM D-471, Reference Fuel D. (6) for 14 days. | | | |
| Volume change | Record | 6211 | 17% |
| Initial tensile strength retained (1) | | | |
| a. Interior compounds & barrier, (3) % (min) | 40% or 600 PSI | 6111 (para. 4.8.1 of Method 6111 applies) | 896 PSI or 60% of Spec. |
| b. Exterior top compounds, (4) % (min) | 40% or 600 PSI | | |
| c. Exterior bottom compounds, (4) % (min) | 35% or 525 PSI | | |
| After accelerated weathering for 500 hrs (exterior compounds only) (4) (5) | | | |
| Fuel contamination (interior compounds only) | | | |
| Unwashed existent gum, mg/100 ml (max) | 20 | 4.4.1 | 8.4 mg/100 ml |
| Heptane washed existent gum, mg/100 ml (max) | 5 | 4.4.1 | 4.6 mg/100 ml |

TABLE 3 - CHARACTERISTICS OF CURED ELASTOMERIC COATING COMPOUNDS
(CONTINUED)

FOOTNOTES:

- (1) The percentage tensile strength retained is:
$$\frac{\text{Tensile strength retained after immersion or weathering} \times 100}{\text{Initial tensile strength value actually obtained (avg. of 3 or more samples)}}$$
- (2) Tolerance for immersion periods: ± 2 hours.
- (3) Interior compounds: All compounds between the fabric and the inside of the tank.
- (4) Exterior compounds: All compounds between the fabric and the outside of the tank.
- (5) Exposed at 10 % elongation with alternate Corex D filters in place.
- (6) 60% iso-octane and 40% toluene.
- (7) The thickness required by the Federal Test Method would not fit into Reeves test fixture.

TABLE 4 - CHARACTERISTICS OF COATED FABRIC

| PROPERTY | REQUIREMENT | TEST PARAGRAPH OR TEST METHOD OF FED. STD. NO. 191 | ACTUAL |
|---|--|--|---|
| Thickness, mils | Record | 5030-1 | 35.5 Mil's |
| Weight | Record | 5041 | 30.62 |
| Diffusion rate | .10 fl oz/sq ft per 24 hours (max) | 4.4.2 | .097 |
| Tearing strength, warp and fill | 50 pounds (min) | 5134 | W 137.2 F 149.9 |
| Breaking strength, warp and fill | 1000 pounds/inch (min) | 5102 2/ | W 802 F 668 |
| Puncture resistance | 200 pounds (min) | 4.4.3/5120 | 265 |
| Low temperature crease resistance: | | | |
| a. Appearance after unfolding | No cracking, peeling or delaminating | 4.4.4 | PASS |
| b. Diffusion rate after low temperature crease resistance test | .10 fl oz/sq ft per 25 hours (max) | 4.4.2 | .09 |
| Fungus resistance | No cracking, blistering, or delamination of coating. Retention of breaking strength 50% (min). | 5762 5/ | |
| Blocking | Specimens to separate within 5 sec. | 4.4.5 | PASSED |
| Coating adhesion (initial) | 20 pounds/inch (min) | 4.4.6 | (Adhesive Bonded) 18.75 (Heat Sealed) 15.1 |
| Coating adhesion after immersion in distilled water at 160°F ± 2°F for the following durations: | | | |
| 14 days | 10 lbs/in or 30% of initial 4/ (min) | 4.4.6 | 11 |
| 42 days | 5 lbs/in or 20% of initial 4/ (min) | 4.4.6 | 9.4 |

TABLE 4 - CHARACTERISTICS OF COATED FABRIC
(CONTINUED)

| PROPERTY | REQUIREMENT | TEST PARAGRAPH OR TEST METHOD OF FED. STD. NO. 191 | ACTUAL |
|--|--------------------------------------|--|--------|
| Coating adhesion after fuel immersion in reference fuel D at 6/ 160°F ± 2°F for the following durations: 14 days 42 days | 10 lbs/in or 40% of initial 4/ (min) | 4.4.6 | 15.6 |
| | 10 lbs/in or 30% of initial 4/ (min) | 4.4.6 | 11.2 |
| | | | |

FOOTNOTES:

- 1/ Properties after cure.
- 2/ Specimens shall be prepared by stripping two (2) threads from each side of the specimen. (The specimens shall be 1.0 inch wide after removal of threads). If thread-stripping is not possible, extreme care shall be taken to cut specimens parallel to and following the curvature of the threads of the fabric.
- 3/ Specimens shall be exposed to accelerated weathering before stripping or cutting to 1.0-inch width. (Note 1.) Specimens shall be tensioned in the direction of the 6-inch length, under a stress of 100 lb/in ± 5 lb/in for 60 seconds. While still under stress the specimen shall be clamped to maintain the initial (one minute) elongation without slippage. While still so elongated, specimens shall be exposed by Method 5804 of FED. TEST METHOD STD. 191, with the tank exterior coating facing the carbon arc. Alternate Corex D filters shall be removed during test.
- 4/ Whichever is the greater.
- 5/ Method 5762 except that the specimens shall be prepared by Note 1/ after soil burial and the number of specimens shall be reduced from 40 to 12. Leaching of the specimens is unnecessary.
- 6/ Reference fuel D is ASTM D-471, 50% Iso-octane and 40% toluene.

TABLE 5 - CHARACTERISTICS OF BONDED FITTINGS

| PROPERTY | REQUIREMENT | TEST PARAGRAPH OR TEST METHOD OF FED. STD. NO. 191 | ACTUAL |
|---|--|--|----------------------------|
| Aluminum to coated fabric bond strength (initial) | 1000 lbs/in (min) | 4.4.9 & 4.4.9.1 | 1028 lbs/in |
| Bond strength of fitting after immersion in distilled water at 160°F ± 2°F for the following durations: 14 days 42 days | 700 lbs/in (min) 500 lbs/in (min) | 4.4.9.2 4.4.9.2 | 97.4 lbs/in 0 |
| Bond strength of fitting after fuel immersion in ref. fuel D 3/ at 160°F ± 2°F for the following durations: 14 days 42 days | 700 lbs/in (min) 500 lbs/in (min) | 4.4.9.2 4.4.9.2 | 406.8 lbs/in 507 lbs/in |
| Dead load shear resistance under 100 lbs/in stress at 200°F for 8 hrs. | .125 in slippage (max) | 4.4.9.3 | PASSED |
| Peel adhesion of aluminum strip to coated fabric (initial) | 20 lbs/in (min) | 4.4.10 | 30.5 lbs/in |
| Peel adhesion of aluminum strip to coated fabric after immersion in distilled water at 160°F ± 2°F for the following durations: 14 days 42 days | 10 lbs/in or 30% of initial (min) 2/ 5 lbs/in or 20% of initial (min) 2/ | 8031/4.4.10.1 8031/4.4.10.1 | 2.1 lbs/in 0 |
| Peel adhesion of aluminum strip to coated fabric after immersion in ref. fuel D 3/ at 160°F ± 2°F for the following durations: 14 days 42 days | 10 lbs/in or 40% of initial (min) 2/ 10 lbs/in or 30% of initial (min) 2/ | 8031/4.4.10.1 8031/4.4.10.1 | 7.03 0 |

FOOTNOTES:

1/ Properties after cure.

2/ Whichever is greater.

3/ Reference fuel D is ATSM D-471, a blend of 60% iso-octane and 40% toluene.

TABLE 6 - CHARACTERISTICS OF SEAMS

| PROPERTY | REQUIREMENT | TEST PARAGRAPH OR TEST METHOD OF FED. STD. NO. 191 | ACTUAL | |
|---|--|--|-------------|------------|
| | | | Adhesive | Heat Seal |
| Breaking strength (initial) Breaking strength after immersion in distilled water at 160°F ± 2°F for the following durations: 14 days 42 days | 1000 pounds/inch (min) <u>2/</u> | 8311/4.4.7 | 967 | 913 |
| Breaking strength after immersion in ref. fuel D 4/ at 160°F ± 2°F for the following durations: 14 days 42 days | 800 lbs/in (min) 400 lbs/in (min) | 8311/6001/4.4.7 8311/6001/4.4.7 | 833 933 | 895 897 |
| Dead load shear resistance under 100 lb/ inch stress at 200°F for 8 hours | 800 lbs/in (min) 400 lbs/in (min) | 8311/6001/4.4.7 8311/6001/4.4.7 | 763 713 | 756 835 |
| Peel adhesion (initial) Peel adhesion after immersion in dis- tilled water at 160°F ± 2°F for the following durations: 14 days 42 days | .125 in slippage (max) 20 pounds/inch (min) | 4.4.8 8011 | PASS 35 | PASS 25 |
| Peel adhesion after immersion in ref. fuel D 4/ at 160°F ± 2°F for the following durations: 14 days 42 days | 10 lbs/in or 30% of initial (min) <u>3/</u> 5 lbs/in or 20% of initial (min) <u>3/</u> | 8011/6001/4.4.7 8011/6001/4.4.7 | 11.9 9.4 | 12.3 0 |
| | 10 lbs/in or 40% of initial (min) <u>3/</u> 10 lbs/in or 30% of initial (min) <u>3/</u> | 8011/6001/4.4.7 8011/6001/4.4.7 | 11.4 6.8 | 17.8 0 |

FOOTNOTES:

- 1/ Properties after cure.
- 2/ All specimens must break in the coated fabric. Failure of any specimen in a seam area at any value shall constitute failure of this test.
- 3/ Whichever is the greater.
- 4/ Reference fuel D is ATSM D-471, a blend of 60% iso-octane and 40% toluene.

APPENDIX "A"

Elastofab
Oakridge Road
Oakridge NJ 07438

Bostik
103 Happer Avenue
Hawthorne NJ 07506

Hughson Chemicals
2000 W. Grandview Blvd.
Erie PA 16512

Century Fastener
50-20 Ireland Street
Elmhurst NJ 11379

Astrup Company
2937 W. 25th Street
Cleveland OH 44113

DBR Distributing Company
83 North Main Street
Yardley PA 19067

SAS Gasket and Supply Co.
275 Adams Blvd.
Farmingdale NY 11735

Protecto Seal Company
227 Foster Avenue
Bensenville IL 60106

PM Manufacturing
P. O. Box K
Eaton Park FL 33840

Speakman
42 Salisbury
Dover DE 19901

B. F. Goodrich
500 S. Main Street
Akron OH 44318

Evertite
254 W. 54th.
New York NY 10019

Cast-Rite Corp.
515 East Airline Way
Gardena CA 90248

Unirubber, Inc.
130 A East 35th. Street
New York NY 10016

Easton Steel
P. O. Box 599
Easton MD 21601

Bronze & Plastic Specialties
2025 Inverness Avenue
Baltimore MD 21230

Fisher Scientific
191 S. Gulph Street
King of Prussia PA 19406

Halko
500 Duck Creek Road
Clayton DE 19938