

AD-A116 713

AIR FORCE INST OF TECH WRIGHT-PATTERSON AFB OH
INTERACTIONS OF RADIOFREQUENCY RADIATION WITH NITELLA: ELECTRIC--ETC(U)
MAR 82 L S WONG
AFIT/NR/82-117

F/6 6/18

UNCLASSIFIED

NL

1 of 2

AD
A116 713



1111
1111
1111

1111

001 02 0

001 02 0

UNCLASS

SECURITY CLASSIFICATION OF THIS PAGE (When Data Entered)

1

REPORT DOCUMENTATION PAGE

READ INSTRUCTIONS BEFORE COMPLETING FORM

1. REPORT NUMBER AFIT/NR/82-11T		2. GOVT ACCESSION NO. AD-A116713		3. RECIPIENT'S CATALOG NUMBER	
4. TITLE (and Subtitle) Interactions of Radiofrequency Radiation With NITELLA: Electrical Excitation And Perturbation Of The Control Of Cytoplasmic Streaming				5. TYPE OF REPORT & PERIOD COVERED THESIS/DISSERTATION	
7. AUTHOR(s) Lenora S. Wong				6. PERFORMING ORG. REPORT NUMBER	
9. PERFORMING ORGANIZATION NAME AND ADDRESS AFIT STUDENT AT: Dartmouth College				8. CONTRACT OR GRANT NUMBER(s)	
11. CONTROLLING OFFICE NAME AND ADDRESS AFIT/NR WPAFB OH 45433				10. PROGRAM ELEMENT, PROJECT, TASK AREA & WORK UNIT NUMBERS	
14. MONITORING AGENCY NAME & ADDRESS (if different from Controlling Office)				12. REPORT DATE March 1982	
				13. NUMBER OF PAGES 83	
16. DISTRIBUTION STATEMENT (of this Report) APPROVED FOR PUBLIC RELEASE; DISTRIBUTION UNLIMITED				15. SECURITY CLASS. (of this report) UNCLASS	
				15a. DECLASSIFICATION/DOWNGRADING SCHEDULE	
17. DISTRIBUTION STATEMENT (of the abstract entered in Block 20, if different from Report)					
18. SUPPLEMENTARY NOTES APPROVED FOR PUBLIC RELEASE: IAW AFR 190-17 22 JUN 1982					
19. KEY WORDS (Continue on reverse side if necessary and identify by block number)					
20. ABSTRACT (Continue on reverse side if necessary and identify by block number) ATTACHED					

AD A116713

DTIC FILE COPY

Lynn E. Wolaver
 LYNN E. WOLAVER
 Dean for Research and
 Professional Development
 AFIT, Wright-Patterson AFB OH

82 07 07 056

DTIC
 ELECTRIC
 S JUL 09 1982
 E

DD FORM 1 JAN 73 1473

EDITION OF 1 NOV 55 IS OBSOLETE

UNCLASS

SECURITY CLASSIFICATION OF THIS PAGE (When Data Entered)

82-11

INTERACTIONS OF RADIOFREQUENCY RADIATION WITH NITELLA:
ELECTRICAL EXCITATION AND PERTURBATION OF
THE CONTROL OF CYTOPLASMIC STREAMING

A Thesis
Submitted to the Faculty
in partial fulfillment of the requirements for the
degree of
Master of Arts
by
Lenora S. Wong

DARTMOUTH COLLEGE
Hanover, New Hampshire
March 1982

Examining Committee:

Alvia Horgan Allen
Chairman
Samuel I. Wiley
John Walsh

Dwight Lahr
Dean of Graduate Studies



Accession For	
NTIS GRA&I	<input checked="" type="checkbox"/>
DTIC TAB	<input type="checkbox"/>
Unannounced	<input type="checkbox"/>
Justification	
By _____	
Distribution/	
Availability Codes	
Dist	Avail and/or Special
A	

ABSTRACT

Radiofrequency radiation (RFR) of 0.5 Hz - 2.5 GHz, at field strengths on the order of 10 v/cm, has been shown to interact with isolated Nitella internodal cells in two separate and frequency dependent manners. At frequencies up to ca. 10 KHz, RFR acts to directly excite the cell membrane, eliciting an action potential and halting cytoplasmic streaming. There is no reason to believe the RF induced action potentials and accompanying streaming cessations occur through a mechanism different from that which results from conventionally applied excitatory stimuli.

Neither excitation nor streaming cessation result from exposure to RFR of 100 KHz - 2.5 GHz. Alterations in the cellular potential and streaming velocity due to irradiation by these higher frequencies are analogous to those which result from increases in temperature. It is likely that these hyperpolarizations and transient increases in streaming velocity are of purely thermal origin.

Microscopic observations of the streaming in cells exposed to RFR gave no evidence of direct action by the radiation upon the mechanism which generates the motive force. Streaming alterations, however, did indirectly indicate the existence of a field induced disruption of the calcium ion release which normally occurs upon membrane excitation. On the basis of these observations and previously reported theoretical models of RF

interactions with biological systems, a molecular mechanism for the electrically mediated release of calcium ion is presented.

ACKNOWLEDGMENT

The present work was completed only with the efforts and support of many, from my fellow graduate students to the United States Air Force. Special thanks, however, are due to the following:

Dr. Nina S. Allen; for her support and encouragement of this work and for the many opportunities she provided for me to experience, learn, and enjoy;

Dr. Samuel J. Velez; for his whole-hearted adoption of me as a member of his own lab;

Dr. John Walsh; for his role in guiding my studies here; and Bob Layman; for his many hours of advice and patience.

I also gratefully thank Dr. William J. Adelman, Jr. (Marine Biological Laboratory, Woods Hole) and Steve Ross (University of Toronto) for their gracious hospitality and instruction. A most special acknowledgment goes to both Wanda Garrison, who so elegantly prepared the figures for this text, and Sue Stearns, who very kindly assumed an instrumental role in the preparation of this manuscript.

Last, but certainly not least, I thank my family and dear friends who supported me throughout this study with their encouraging thoughts and prayers.

DEDICATION

This work is dedicated to my parents, Howard and Esther Wong, who encourage me in every aspect of my life as both their child and their equal; and to the Almighty Father, who continues to bless me in so many ways.

TABLE OF CONTENTS

Section	
ABSTRACT	ii
ACKNOWLEDGMENT	iv
DEDICATION	v
LIST OF TABLES	ix
LIST OF FIGURES	x
INTRODUCTION	1
I. Experimental Materials, <u>Nitella</u>	2
A. Cytoplasmic Streaming	4
B. Membrane Electrical Behavior	6
C. The Characean Action Potential	8
D. Excitability and the Cessation of Streaming ...	10
II. Radiofrequency Radiation (RFR)	12
A. Radiofrequency Bioeffects	13
B. Athermal Interactions - Theoretical and Experimental Aspects	16
MATERIALS AND METHODS	20
I. Biological Materials	20
II. Exposure System	21
A. The Irradiation Chamber	21
B. Exposure Procedures	24
C. Detector Electronics	25
1. Intracellular Recording	25
2. Temperature Monitoring	26
D. Microscopy - Measurement of Streaming Rates ...	26

Section	page
RESULTS	28
I. The Response of <u>Nitella</u> to Control Stimuli	30
A. Membrane and Streaming Response to an Electrical Stimulus Pulse	30
B. Membrane and Streaming Response to Repetitive Stimulus Pulses	32
C. Streaming Recovery After the Cessation of Cyclosis	32
D. Streaming Response of Cells Used During Winter Months	34
E. Response to Static Electric Fields	34
II. <u>Nitella</u> Response to Radiofrequency Radiation(RFR)	36
A. Streaming Response and Its Frequency Dependence ..	36
B. Streaming Recovery After Exposure to RFR	40
C. Membrane Response to Radiofrequency Radiation ...	43
1. Response to Frequencies Greater Than 1 MHz ...	43
2. Hyperpolarizing Response to Frequencies of 100 KHz - 1 MHz	43
3. Depolarizing Response to Frequencies of 50 Hz - 1 KHz	46
D. 1 MHz Irradiation of Cells Rendered Inexcitable by MnCl ₂	48
DISCUSSION	52
I. Determination of the Nature of RF Interaction - Thermal or Athermal?	53
II. Cellular Responses to Frequencies Above 100 KHz - Mechanisms of RF Interaction	56
A. Thermally Induced Effects	56
B. Possible Athermally Induced Responses in Cells Exposed to 1 MHz	57
III. Cellular Response to Frequencies Below 10 KHz - Direct Electrical Excitation	58

Section	page
IV. Insights Into the Electrically Associated Control of Cytoplasmic Streaming - Speculations on the Mechanism of Calcium Ion Release	61
A. Proposed Model of Electrically Induced Calcium Ion Release	61
B. Biological Basis of the Model	64
C. Are the Proposed Field Effects Likely to Occur?..	66
D. Other Electrical Modifications of Ca ⁺⁺ Release ..	67
V. Summary	69
APPENDIX	71
REFERENCES	74

LIST OF TABLES

Table	page
I. Comparisons of Nerve and <u>Nitella</u> Electrical Characteristics	7
II. Some Investigation of Radiofrequency Bioeffects	14
III. The General Electrical and Streaming Responses of <u>Nitella</u> Exposed to Radiofrequency Radiation	29
IV. Incidence of Streaming Recovery During Continued Exposure to RFR	41
V. General Electrical Response of <u>Nitella</u> Exposed to Radiofrequency Radiation	45

LIST OF FIGURES

Figure	page
1. <u>Nitella</u> , Growth Habit and Structure	3
2. The Action Potential of <u>Nitella</u>	9
3. Overall Diagrammatic of the Irradiation Circuitry	22
4. The Chamber Used for Radiofrequency Irradiation of <u>Nitella</u>	25
5. Patterns of the Slowdown of Streaming Observed in Cells Exposed to Subthreshold Stimulus Pulses	31
6. The Recovery of Cytoplasmic Streaming After Cessation by a Superthreshold Stimulus	33
7. The Streaming Response of a Cell Exposed to a Static Electric Field of Increasing Strength	35
8. The Frequency - Response Relationship in <u>Nitella</u> Exposed to a Range of Radiofrequencies	37
9. The RFR Frequency Dependence of the Voltage Necessary for Excitation of <u>Nitella</u>	39
10. Streaming Recovery During Irradiation By 1 MHz	42
11. Streaming Recovery After Irradiation By RFR	44
12. Hyperpolarizing Response to 1 MHz Irradiations	47
13. Intracellular Responses to 50 Hz and 1 KHz Irradiations	49
14. Intracellular Responses to 100 Hz and 1 KHz RFR	50
15. The Variation of Streaming Velocity and Membrane Potential with Changes in Temperature	54
16. A Model for RFR Perturbation of the Release of Calcium Ion From <u>Nitella</u> Plasma Membrane	55
17. The Electromagnetic Spectrum	71

INTRODUCTION

Internodes of the characean alga Nitella were investigated to determine a mode of interaction between radiofrequency radiation (RFR, see Appendix I for background information and definition of terms) and isolated, excitable cells and to gain insight into the mechanism of the control of cytoplasmic streaming in these giant cells. The advantages of using this organism for this type of study are manifold. The characeae, long known to respond to electrical stimuli with an action potential similar to that of nerves, provide a means of studying in vivo cellular response without the added artifacts typically associated with responses from surrounding tissue (Osterhout, 1927) or the trauma of isolation from surrounding cells (Liu, et. al., 1982). These cells are easily obtained and cultured and exhibit rapid and continuous cytoplasmic streaming, which is sensitive to the intracellular potential (Osterhout, 1927; Hill, 1941; Findlay, 1959; Pickard, 1968), temperature (Hayashi, 1960; Pickard, 1974), ionic concentrations (Tazawa and Kishimoto, 1964; Barry, 1968; Tazawa, et. al., 1976; Hayama and Tazawa, 1980), and other stimuli (Harvey, 1942; Kishimoto, 1968; Zimmerman and Beckers, 1978).

It has been reported that microwave frequencies of 2.0-2.5 GHz, 3.15 v/cm can induce the cessation of cytoplasmic streaming in Nitella furcata (Straus, 1979). An abrupt halt of cyclosis occurs almost any time an action potential is elicited in the characeae (Findlay, 1959; Hope and Walker, 1975), and Straus

suggested that a microwave specific excitation of the cells might be the cause of the streaming response. Later investigations with characean internodes, however, showed no changes in the electrical state of the membrane in response to microwave exposure. Liu, et. al. (1982) exposed Chara corallina to 2.5-3.0 GHz microwaves, 36 w/kg for up to 60 minutes and found no changes in resting potential, action potential characteristics, or excitability. In the light of these conflicting reports, it is of interest to investigate both the existence of a streaming response to nonionizing radiation and the relationship of this response to the membrane potential in isolated internodal cells of Nitella. An understanding of the effects of various types of electromagnetic radiation (EMR) on this isolated system might serve as a model for the interaction of EMR with other types of excitable cells.

I. EXPERIMENTAL MATERIALS, NITELLA

The giant characean alga Nitella can be found in most areas where there are bodies of fresh water. Large clumps or meadows of the plant, anchored to mud bottoms by rhizoid cells, can grow up to several meters high. Nitella exists as filaments of long, cylindrical, unicellular internodes (up to several centimeters long) and smaller multicellular nodes (Fig. 1a). Isolated cells are known to survive for several weeks or months in the laboratory (Hope and Walker, 1975; Allen, personal communication).

Figure 1. Nitella, Growth Habit and Structure.

- a. Individual plants can grow to several meters in height.
- b. Single internodes have orderly chloroplast rows and spiral indifferent zones which are devoid of chloroplasts. The lower figure is a magnification of the boxed area indicated on the internode. The bar represents 10 μm .
 - a). Tonoplast Membrane
 - b). Flowing Endoplasm
 - c). Subcortical Fibrils (in cross section)
 - d). Chloroplasts Within the Stationary Cortex
 - e). Cell Wall (reduced here for clarity)
 - f). Indifferent Zone

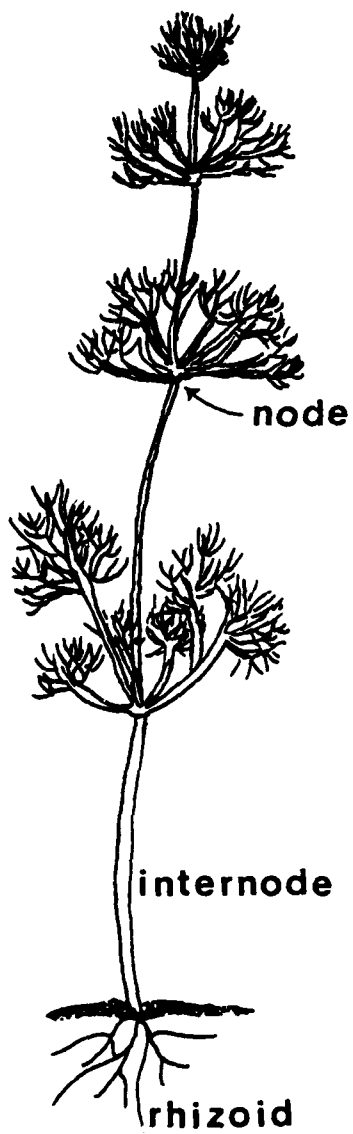

A

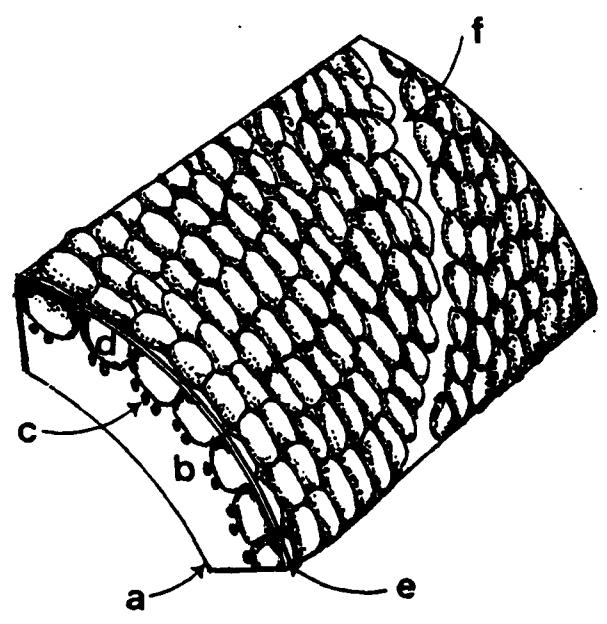
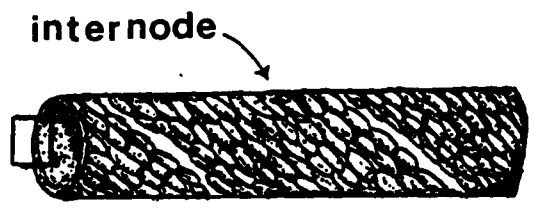

B

The characeae have long been favorites of biologists because of their easy availability, giant size, continuous and stable cytoplasmic streaming (up to 80 $\mu\text{m/s}$), and membrane excitability. Many investigations and manipulations of these cells, in fact, have focused on the last two characteristics, streaming and excitability, as both separate and related phenomena (for review, see Allen and Allen, 1978; Kamiya, 1981).

A. Cytoplasmic Streaming

Characean internodes provide a classic example of continuous rotational cytoplasmic streaming, with the endoplasm moving as a belt around the periphery of the cell interior. The overall cell architecture is shown in Figure 1b. The plasma membrane lies just inside the cell wall and surrounds the cortex (stationary layer of ectoplasm, containing chloroplast rows and subcortical fibrils). Inside the cortex are the flowing endoplasm, bordered by the tonoplast membrane which also surrounds the large central vacuole. Along the length of the cell are two spiral indifferent zones, devoid of chloroplasts and cytoplasmic flow.

Various mechanisms explaining rotational streaming in the charophytes have been proposed. Kamiya (1960) interpreted velocity profiles of the flowing endoplasm as evidence for an "active shearing" force localized at the endoplasm-ectoplasm interface. The existence of subcortical fibrils (bundles of microfilaments), in rows parallel to the chloroplasts and at the exact site of the predicted force generation (Nagai and Rebhun, 1966; Kamitsubo, 1972a), and their apparent indispensability for

streaming (Kamitsubo, 1972a; 1980) supported this interpretation. S-1 decoration of the microfilament bundles demonstrated that they were composed of F-actin (Palevitz, et. al., 1974; Williamson, 1974; Palevitz and Hepler, 1975). When decorated with heavy meromyosin, HMM, the filaments show polarization in the direction pointing opposite that of endoplasmic flow (Kersey, et. al., 1976). This fact, along with the ATP-dependent attachment and movement of particles along the fibrils (Williamson, 1975), the identification of a myosin-like protein at the endoplasm-ectoplasm interface (Chen and Kamiya, 1975), and the isolation of Nitella myosin which shows Mg-ATPase activity in the presence of skeletal F-actin (Kato and Tonomura, 1977) led to the generally accepted view that the force generation stems from an acto-myosin type interaction between the subcortical fibrils and endoplasmic myosin (see Allen and Allen, 1978; Kamiya, 1981).

The discovery of endoplasmic filaments (Allen, 1974; Allen, et. al., 1976) and the subsequent investigations of the nature of the endoplasm (Allen and Allen, 1978) showed the cytoplasm to be of much lower viscosity and greater internal structure than previously believed. Microscopic observation of particle movements in Nitella (Allen, 1974) revealed particle associations with the endoplasmic filaments. This discovery raised questions as to the actual site of motive force generation--whether it was localized only at the endoplasm-ectoplasm interface or at both the interface and along the endoplasmic filaments.

Regardless of where or how the motive force is actually generated, it is certain that the structures found in isolated

endoplasmic droplets (Kuroda, 1964; Kamitsubo, 1972b) and shown in ultrastructural studies (Allen, 1980) must be considered in any theory concerning the movement of the cytosol.

B. Membrane Electrical Behavior

The characean membrane (here, the term "membrane" refers to the composite system of cell wall, plasma membrane, and tonoplast), like that of nerve, can be represented in electrical terms as an equivalent circuit with a resistance in parallel with a capacitance (Cole and Curtis, 1938). The Nitella membrane resistance (R) is 40-50 $k\Omega\cdot\text{cm}^2$ at rest (Tazawa, et. al., 1976) and decreases to about 4 $K\Omega\cdot\text{cm}^2$ during activity (Kishimoto, 1966). At rest, the membrane is more conductive to depolarizations ($R = 20 K\Omega\text{cm}^2$) than to hyperpolarizations ($R = 60 K\Omega\text{cm}^2$) (Findlay, 1959; Kishimoto, 1965). The capacitance of the membrane is $1 \mu\text{F}/\text{cm}^2$ (Hope and Walker, 1975).

The excitable membrane of Nitella is similar to that of nerve; Table I compares some electrical characteristics of the two cells. The membrane response to electrical stimuli is analogous to that of axons and other excitable cells. Moderate depolarizing steps bring about transient depolarizations followed by steady repolarizations. Larger depolarizing pulses can bring on an action potential, and hyperpolarizing stimuli cause only constant, steady hyperpolarizations (Kishimoto, 1964, 1966).

Table I. COMPARISONS OF NERVE AND NITELLA ELECTRICAL CHARACTERISTICS
(From Kuffler and Nicholls, 1976; Hope and Walker, 1975).

Characteristic	Nerve		Nitella	
Resting Potential	-70 mv		-125 mv	
Ionic Concentrations (mM) :	[ion] _i	[ion] _o	[ion] _i	[ion] _o
K ⁺	400	20	110	0.5
Na ⁺	50	440	26	0.28
Cl ⁻	40-150	560	136	0.03
Nernst Equilibrium Potentials:				
K ⁺	-75 mv		-178 mv	
Na ⁺	+55 mv		-76 mv	
Cl ⁻	-65 mv		+46 mv	
Membrane Resistance	1-5 KΩ·cm ²		40-50 KΩ·cm ²	
Membrane Capacitance	1 μF/cm ²		1 μF/cm ²	
Time Constant	0.5-5.0 msec		50 msec	
Space Constant	millimeters		centimeters	
Action Potential:				
Ions involved	Na ⁺ in , K ⁺ out		Cl ⁻ out, K ⁺ out	
Time course	10 ⁻³ sec		1 sec	

C. The Characean Action Potential

A phenomenon long associated with charophyte cells is their ability to respond to certain stimuli by conducting an electric depolarization along their length, the response including the excitation of both plasma and tonoplast membranes. These two separate action potentials almost always occur together so that recordings made from the vacuole are often used to monitor the electrical response of the cell (Hope and Walker, 1975). Figure 2 shows a typical action potential seen in the present work.

The onset of an action potential is signalled by a dramatic increase in membrane conductance to chloride ion, with a resulting inward current due to chloride efflux. As the resting potential becomes depolarized, the membrane becomes increasingly permeable to potassium ion and allows an outward current, carried by K^+ efflux, to rise rapidly. In the meantime, chloride conductivity continues to increase, then spontaneously decline. When the Cl^- and K^+ currents are equal, the depolarization reaches its peak. Conductance to Cl^- then declines still further, the cell potential becomes more negative, and the K^+ permeability subsequently decreases. After a short time the cell potential reaches its resting level, although the membrane remains inexcitable (refractory) for several minutes. During this time, the channels involved in the action potential event cannot be reactivated.

As in nerve, the action potential is conducted away from the site of stimulation by local circuit currents of sufficient magnitude to bring the adjacent areas of the membrane to

Figure 2. The Action Potential of Nitella.

This recording was made from the vacuole, following a super-threshold stimulus pulse at $t=2$. The increase in membrane permeability to chloride allows the vacuolar potential, ϕ , to rise from its resting level (-125 mv) toward the equilibrium potential for chloride, E_{Cl} (+46 mv). As the potassium permeability increases, the efflux of K^+ tends to bring the potential back down toward E_K (-178 mv). Note that the time scale is in seconds.

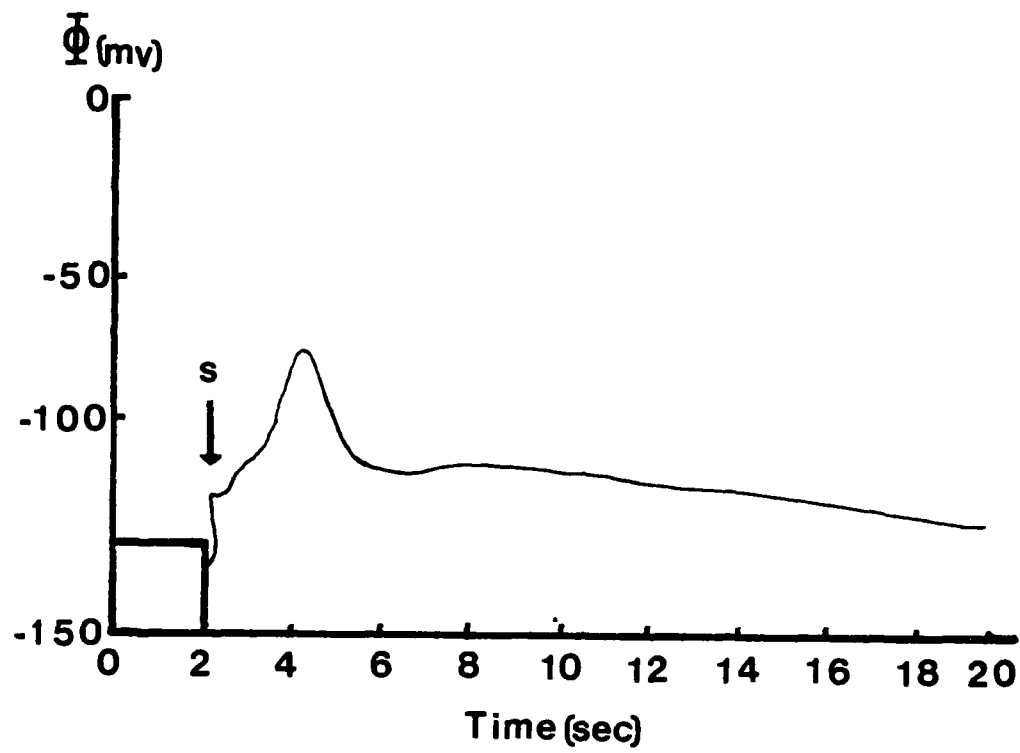

threshold (Blinks, et. al., 1928; Kishimoto, 1968). Conduction occurs across the entire cell unless prevented from propagating, for example by voltage clamp (Kishimoto, 1966) or high resistance electrical barriers (Kishimoto and Akabori, 1959).

D. Excitability and the Cessation of Streaming

An interesting occurrence associated with the action potential is the abrupt cessation or inhibition of cyclosis. Studies correlating the stoppage of streaming with the action potential report that:

- 1) Abrupt and complete cessation of streaming, which occurs at the peak of the action potential, is seen whenever the cell is excited (Kishimoto and Akabori, 1959; Findlay, 1959; Tazawa and Kishimoto, 1968; Pickard, 1968).
- 2) Streaming rate is largely independent of the vacuolar voltage below the threshold potential (Kishimoto and Akabori, 1959; Pickard, 1968), although some slowing and gradual cessation due to prolonged subthreshold stimuli can occur (Hill, 1941; Pickard, 1968).
- 3) The effect is cumulative; that is, a train of successive action potentials halts cyclosis for a longer period than a single one (Kishimoto and Akabori, 1959).
- 4) Hyperpolarizing stimuli are generally ineffective in eliciting an action potential and streaming cessation (Tazawa and Kishimoto, 1964).

How the action potential brings about streaming cessation is not known, although it has been shown that neither membrane

excitation nor electric current alone directly affects cyclosis (Kishimoto and Akabori, 1959; Pickard, 1968; Tazawa, et. al., 1976). The essential role of free calcium in the coupling of membrane excitation with streaming cessation has been demonstrated. Tazawa and Kishimoto (1964), using Nitella perfused with artificial vacuolar sap, showed that a calcium concentration in the vacuole of 3mM or more is necessary to maintain normal streaming and excitation characteristics. Concentrations in excess of 50mM, however, inhibited or stopped cyclosis. Barry (1968) showed the necessity for a critical ratio of calcium to other divalent cations (for example Ca/Mg) in the external medium in order to obtain streaming cessation upon action potential occurrence. The Ca /Mg ratio was about 1/50, comparable to the Ca/Mg of 1/30 necessary for in vitro skeletal muscle contraction. He concluded that extracellular calcium entered the cytoplasm and interfered with the streaming mechanism in a manner analogous to the role of Ca^{++} in skeletal muscle contraction.

In contrast, Pickard (1971) correlated calcium influx with the time required for the cessation of streaming to occur after excitation to theoretically show that no influx of Ca^{++} was required for streaming cessation, but rather, that any free calcium needed to effect the turnoff could be provided by internal sources. Hayama, et. al. (1979) subsequently showed that streaming recovery was independent of external calcium concentrations, suggesting again that external Ca^{++} had no direct influence on streaming. They further suggested that Ca^{++}

released from the plasmalemma upon excitation diffused into the endoplasm to stop chloroplast rotation, after it had effectively halted the movement of the bulk cytoplasm. Hayama and Tazawa (1980) showed that calcium above 10^{-4} M reversibly inhibited chloroplast rotation in isolated droplets of Chara cytoplasm, suggesting an endoplasmic calcium sequestering system.

From the aforementioned investigations of the role of calcium in the cessation of streaming, it appears that an action potential induces the increase in intracellular calcium from 10^{-7} M (Williamson, 1975) to above 10^{-6} M (Tazawa, et. al., 1976). The resulting increase in the concentration of free calcium around the force generating complex abruptly halts or inhibits cytoplasmic streaming by interacting with the actomyosin streaming machinery.

II. RADIOFREQUENCY RADIATION (RFR)

In recent years, public concern and scientific interest have arisen in regard to the potential hazards of exposure to various types of nonionizing electromagnetic radiation. Sources of these electric fields include high-voltage transmission lines, communications and radar installations, biomedical and industrial applications, and household microwave ovens. It is likely that large segments of the population are exposed to increasing levels of many types of radiation, the effects of which are not clearly understood.

The first harmful effects from exposure to microwave radiation, cataract formation in dogs, were reported in 1948 by

the Mayo Clinic (see Steneck, et. al., 1980). Since that time, much research has focused on the biological effects of radiofrequency radiation (see Table II); however, variations in exposure methods (for example, continuous wave, pulsed, or modulated) and dosimetry (for example, energy absorbed, applied dose, or specific absorption rate) make the interpretation and comparison of findings difficult, if not impossible.

A. Radiofrequency Bioeffects

Recent investigations of in vitro and in vivo RFR bioeffects have dealt with possible behavioral modifications, developmental effects, and changes in immune responses of laboratory animals. The effects of RFR on the growth and function of more primitive systems have also been studied. Blackman, et. al. (1975) exposed E. coli to 1.7 and 2.5 GHz microwaves (MW) and reported no evidence of RF induced growth inhibition. Some growth enhancement was observed and attributed to heating effects from the exposure. Greenebaum, et. al. (1979) irradiated the acellular slime mold Physarum polycephalum with low levels of RFR of 45, 60, and 75 Hz, at field strengths of 0.04 - 0.7 v/m, for periods of from 2 months to 5 years. No differences were reported in average chromosome number or chromosome appearance due to the exposure, although a general slowing of cellular processes such as nuclear division cycles and respiration rates was observed.

The effect of RFR on the nervous system has been studied in regard to nervous function, structure, and excitability. Jaffe,

TABLE II. SOME INVESTIGATIONS OF RADIOFREQUENCY BIOEFFECTS

Frequency	Field Parameter	Preparation/ Response Studied	Effect	Investigators
60Hz (CW)	65 Kv/m	Rat sciatic nerve/ neuromuscular function	no field specific effect	Jaffe, et. al., 1981
60Hz (CW)	70-430V/m	Pea root tips/ growth	field specific decrease in growth rate	Miller, et. al., 1980
147MHz (modulated)	0.5- 2.0mw/cm ²	Chick brain tissue/ calcium efflux	field specific increase in efflux only in certain frequency "windows"	Blackman, et. al., 1980
1GHz (modulated)	0.5- 15mw/cm ²	Rat brain tissue/ calcium efflux	no field specific effect	Shelton and Merritt, 1981
2.45GHz (pulsed)	0.4- 80mw/g	Rat brain/ blood-brain barrier	no field specific effect on permeability	Lin and Lin, 1981
1.5-2.45GHz (pulsed & CW)	10mw/cm ³	Aplysia neurons/ firing patterns	field specific changes in rhythms	Wachtel, et. al., 1975
2.45GHz (CW)	1.6w/cm ³	Cat brain and spinal cord/ nervous function	no field specific effect	Taylor and Ashleman, 1975
3.1GHz (pulsed)	4x10 ⁵ w/m ³	Rabbit vagus nerve/ protein transport	no field specific effect	Paulsson, et. al., 1977
38-48GHz 65-75GHz (CW)	177mw/cm ² 292mw/cm ²	BHK 21/C13 cell cultures/ protein synthesis	no field specific effect	Bush, et., al., 1981
2.5GHz (CW)	3.15v/cm	Nitella/ cytoplasmic streaming	field induced cessation of cyclosis	Straus, 1979
1KHz-50MHz (CW)	100v/cm	Chara and Nitella/ membrane potential	field specific hyperpolarizations	Pickard and Barsoum, 1981
2.5GHz (CW)	36w/Kg	Chara/ electrical characteristics	no field specific effects	Liu, et. al., 1982

et. al. (1981) reported no significant differences in the neuromuscular function of rats irradiated with 60 Hz fields, having observed no changes in the response of the plantaris and soleus muscles to stimulations of the sciatic nerve. Paulsson, et. al. (1977) investigated microwave effects on axonal transport in rabbit vagus nerve by following the movement of ³H-leucine-labelled proteins in vitro. They also studied the RF effect on in vitro polymerization and colchicine binding of rabbit brain microtubules. No changes were reported in either preparation due to exposure to 3.1 GHz (up to 4×10^5 v/m³ mean absorbed power density).

Structural alterations were reported to include cytoplasmic vacuolization, axonal degeneration, and decrease in protein synthesis apparatus in certain areas of hamster brain exposed to 2.45 GHz, 20 - 100 mw/ cm² (Albert and DeSantis, 1975). These effects, however, are typical of those found in conventionally heated neurons. Webber, et. al. (1980) showed ultrastructural damage in neuroblastoma cells irradiated with 2.7 GHz, 1.7 - 3.9 Kv/cm microwaves. The disruptions of cell and mitochondrial membranes were attributed to nonthermal, microwave-specific interactions, rather than to any thermally produced perturbations.

Modifications in nerve excitability were reported by McRee and Wachtel (1980). Isolated frog sciatic nerves exposed to 2.45 GHz exhibited prolonged refractory periods and irreversible decreases in vitality (defined as the ability to maintain compound action potentials). The effects were reported to be

nonthermal and micro-wave specific. Wachtel, et. al. (1975) found no change in the action potential shape, height, or duration or in the threshold current needed to excite Aplysia neurons irradiated with 1.5 and 2.45 GHz at fields less than 10 mw/cm^3 . In a few instances, however, changes in the firing rhythms in the Aplysia pacemaker neurons were observed which were opposite to the effects caused by conventionally warming the ganglia. This "thermal irreproducibility" led the investigators to attribute the effects to a nonthermal, microwave-specific interaction.

B. Athermal Interactions - Theoretical and Experimental Aspects

From the aforementioned studies, it is apparent that one of the major difficulties in interpreting the implications of an observed RF bioeffect is in separating the thermal and athermal components. The question of whether the electric field of RFR has a direct action on biological systems; that is, if RFR affects a system independently of thermal agitation, has been dealt with in both theoretical and experimental manners.

Energies associated with radiofrequency and microwave radiation are considerably lower than those required to produce intramolecular alterations or intermolecular bond breaking, so that direct action of RF or MW radiation at a molecular level would require unrealistically high intensity fields. Athermal effects from RF or MW exposures, then, are most likely to result from energy absorption by some molecule or molecular complex and a cooperative energy transfer within a given biological system

(Stuchly, 1979; Frohlich, 1980). At frequencies from 1-40 GHz (which correspond to the period of elastic vibration of many macromolecules), Frohlich (1980) proposed that MW energy might be absorbed and selectively channeled to cause dipolar modes of longitudinal oscillations (similar to the stretching and contracting of a spring) which could then trigger some biological response. At 10 MHz - 300 GHz, however, field induced rotations and orientation of biopolymers (for example, proteins, peptides and amino acids) would transfer absorbed energy as heat, so that nonthermal effects in this frequency range are unlikely (Stuchly, 1979). Nevertheless, it has been suggested that microwave interaction with membrane protein, perhaps in combination with bound water or membrane lipid (Allis and Sinha, 1981), or cooperative interactions between bound ions and membrane glycoproteins (Sheppard, et. al., 1979) might result in altered ion fluxes through or from the membrane. In support of this view, increased Ca^{++} ion efflux from isolated chick brain tissue (Sheppard, et. al., 1979; Bawin, et. al., 1975) and rat pancreatic tissue (Albert, et. al., 1980) have been found to result from exposure to modulated MW fields. In addition, Miller, et. al. (1980) attributed 60 Hz induced growth inhibition of pea root tips to a nonthermal membrane ion transport perturbation.

It is likely, then, that RF interaction with biological systems would affect the cell membrane (Taylor, 1981), where excitation (Stuchly, 1979; Spiegel and Joines, 1973) and rectification, i.e. the unequal passage of hyperpolarizing and

depolarizing currents through the membrane (Pickard and Rosenbaum, 1978; Pickard and Barsoum, 1981; Cain, 1981) should be considered possible effects. Direct microwave induced membrane excitation has not been demonstrated, although a theoretical model based on indirect rectification has been proposed (Cain, 1981). In this model, membrane conductance is controlled by a two-step process in the voltage sensitive channels of excitable cells. In the first step, a voltage sensor is activated by a current; in the second step, the channel is opened. The probability that a channel will open is proportional to the number of voltage sensors in the activated state. It is assumed that the voltage sensing is much faster than the channel opening (ion gating) response. An alternating field could, then, cause a steady shift in the percentage of "active" voltage sensors and result in a slower change in channel conductance. Depending upon the relaxation time of the voltage sensors, the upper frequency for possible interaction with voltage sensors is about 2 KHz (Cain, 1981), although Pickard and Rosenbaum (1978) place the upper limit in the gigahertz region, where resonant interactions between the field and gating particles within the channels might be significant.

Evidence of RF induced potential offsets was seen in isolated Aplysia neurons exposed to 1.5 and 2.45 GHz, where several instances of millivolt changes in resting potential were reported. No changes, however, were noted in membrane conductance (Wachtel, et. al., 1975). Potential offsets of several millivolts were also found in the giant cells of Nitella flexilis

(Pickard, et. al., 1980) and Chara braunii (Pickard and Barsoum, 1981). The cell membrane was found to display rectifier-like behavior up to a frequency of 10 MHz. The effect was shown to be athermal in origin and resulted in hyperpolarizations on the order of 0.5 mv. (Pickard and Barsoum, 1981). The immediate consequences of such changes in cellular potential remain to be seen. Millivolt offsets could have significant effects on the conductance or charge transporting systems of the membrane (Pickard and Rosenbaum, 1978).

The reported cessation of cytoplasmic streaming in Nitella in response to microwave radiation and the long known association of that response with membrane excitation suggested that a MW induced action potential might be the mode of RF interaction with the cells (Straus, 1979). However, it was later shown (Liu, et. al., 1982) that the same MW frequencies had no effect on characean membrane electrical characteristics, so that a microwave interaction with cytoplasmic streaming remains undefined. It is important, then, to first establish the existence of an RF specific effect on characean streaming and to characterize the relationship of that response with the electrical state of the membrane. The present work presents findings in regard to this matter.

MATERIALS AND METHODS

I. BIOLOGICAL MATERIALS

Nitella flexilis obtained from Woods Hole, MA. and N. furcata collected from the Sherrard's pond in Norwich, V.T. were maintained separately in large aquaria and illuminated by scheduled artificial lighting. Nitella obtained from Carolina Biological was used immediately after receipt and temporarily maintained in the original specimen jar. At least 12 hours prior to an experiment, internodes of 1-3 cm length were isolated and allowed to equilibrate in a petri dish of Artificial Pond Water (APW; 0.5 mM CaCl_2 , 0.2 mM NaCl , 0.1 mM KCl , pH 7.0). All experiments were performed using APW as the bathing medium, except in the cases when MnCl_2 solution was used. In those instances, the bathing medium was 6 mM MnCl_2 in 0.5 mM Tris HCl buffer, pH 6.8 (Barry, 1968).

Cells destined for chamber irradiations were carefully placed in the channel and secured into position with a small wax plug. The channel was gently filled with the bathing medium and covered with small glass cover slips. Cells to be intracellularly monitored were impaled with the micropipette, and all internodes were allowed to rest in the chamber for 15 minutes.

All experiments were carried out at room temperature, 20-22°C.

II. EXPOSURE SYSTEM

A. The Irradiation Chamber

Figure 3 is a block diagram of the overall electronic setup described here in detail. The exposure chamber (Fig. 4) was a glass-bottomed lucite channel in which two capacitor plates were oriented parallel to the channel length. For experiments using static electric fields, the plates were made of silver, electrolytically chlorided for reversibility to chloride ion; for experiments with RF fields, the plates were of uncoated silver. No harmful effects from either the plain or chlorided silver plates were seen in any of the cells (Pickard and Barsoum, 1981; personal observation).

The capacitor plates were coupled to the voltage source via copper transitions to a coaxial cable input. Pulse stimuli were obtained from a Grass SD9 stimulator. Continuous wave RF signals up to 1 MHz were provided by a Hewlett-Packard 3311A Function Generator; signals greater than 1 MHz were from a Wavetek RF generator (Model 2002). Output from the Wavetek generator was passed through Hewlett-Packard HP 355D and HP355C Attenuators (up to 1 GHz) and a Hewlett-Packard 8447D amplifier (0.1-1300 MHz). Voltage across the capacitor plates for RF up to 1 MHz was displayed on a model 502, dual trace, Hewlett-Packard oscilloscope, which served as the voltmeter. It was not possible to measure field strengths for RF above 1 MHz.

A major concern was to ensure that unwanted direct current offsets in the applied field were eliminated. A 1 μ F capacitor

Figure 3. Overall Diagrammatic of the Irradiation Circuitry.

The radiofrequency signal from the HP Function Generator (0.5Hz-1MHz) or Wavetek Generator(1MHz-2.5GHz) passed through a 1 μ F capacitor. The signal was coupled to the exposure chamber and voltmeter. Detector electronics are described in the text.

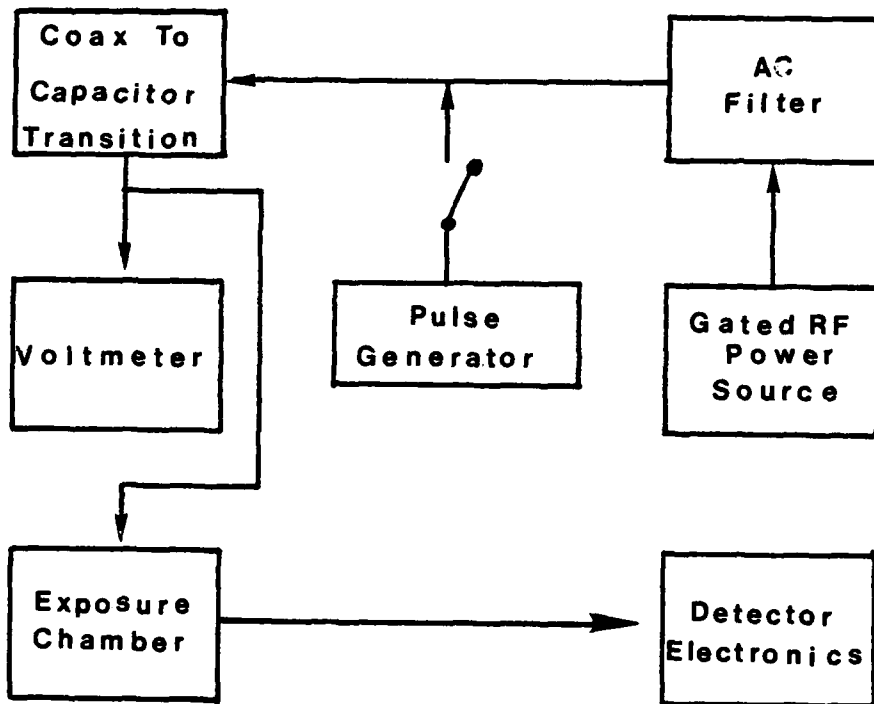
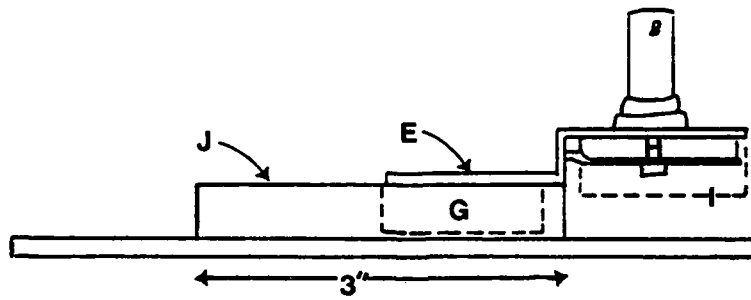
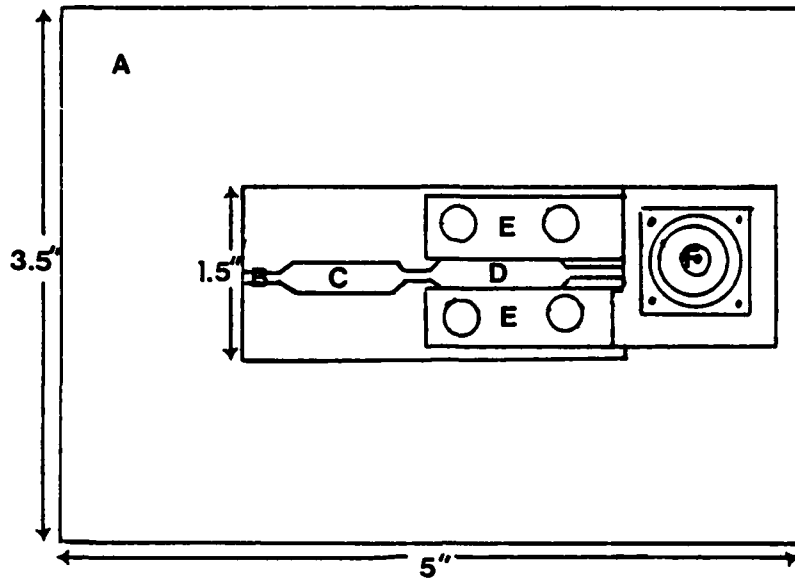

Figure 4. The Chamber Used For Radiofrequency Irradiation of Nitella.

- a. 1/4" glass plate
- b. Entrance for the microelectrode
- c. Channel for the internode. Width=1/4",Depth=1/2"
- d. Irradiation region
- e. Copper transition from coax to the silver plates
- f. Connection for signal input and input to voltmeter
- g. Silver capacitor plates; 1"x1/2"
- h. Teflon insulation
- i. Grounded shield
- j. Lucite chamber



which allowed only the passage of alternating voltage signals was, therefore, placed in series with the RF output. In addition, the silver plates were carefully and scrupulously cleaned and kept dry between each experiment in order to eliminate any surface deposits which might act as sources of low-level RF rectification by causing small d.c. offsets in the applied fields. (Pickard and Barsoum 1981; Pickard, personal communication).

One further addition to the electronics system was a switching device, which was needed to prevent the transmission of high voltage power spikes (often seen upon the turning on or off of either RF source) to the irradiation chamber.

B. Exposure Procedures

Action potentials were elicited by pulse stimuli of 150-200 ms. duration. The minimum voltage required for excitation, V_{th} , was determined for each cell by exposing the cell to pulses of increasing strength until an action potential or abrupt cessation of streaming occurred. A few minutes of rest were allowed between successive pulses to ensure that the cell membrane was at its resting level. After excitation, the cell was allowed to fully recover before it was exposed to any other stimulus.

In many cases, an internode was exposed to only a single frequency of RF; however, if the cell did not show any response to the irradiation or if it had recovered fully, it might be exposed to a range of frequencies. No differences were seen

between the general frequency response of cells exposed in the above manners.

C. Detector Electronics

1. INTRACELLULAR RECORDING

Intracellular measurements were made using glass micropipettes (tip diameter ca. 5 μm) filled with 3M KCl. The microelectrode resistance was about 5M Ω . Pipettes were shielded by a thin coating of colloidal silver paint and grounded in order to reduce extraneous RF pickup. Intracellular readings passed through the microelectrode to a WPI model VF-1 Voltage Follower and into either the HP oscilloscope or a Tektronix Type 5103N Storage Oscilloscope. In some cases, the intracellular recording was connected to a Polygraph, for chart recording.

The micropipette was inserted through one end of the cell and into the vacuole. Streaming was usually unaffected by this procedure.

The major difficulties encountered during intracellular recording of internodes exposed to RFR were ensuring the stability of the microelectrodes and reducing stimulus artifact. Microelectrodes placed alone in the irradiation chamber were stable under RFR, but they showed large and variable electrical artifacts when an internode was added. The Nitella cell, itself, acted as an antenna to transmit electrical noise to the microelectrode. It was, therefore, impossible to check the microelectrode stability to RFR before the intracellular

recordings were performed. In addition, after having been inside a cell and exposed to RFR, the microelectrodes often drifted several tens of millivolts from their original ground level. To ensure the validity of intracellular measurements, it was necessary to follow the procedures listed below:

1. Insert the micropipette and measure cellular responses to electrical stimuli;
2. Remove the micropipette and microscopically check the tip to ensure that the end had not broken;
3. Check the amount of drift in the micropipette;
4. Repeat the irradiations to check the size of the stimulus artifact.

2) TEMPERATURE MONITORING

Differential temperature recordings between the irradiation channel and room conditions were made with an Omega Model 747 Digital Thermistor Thermometer. In experiments during which temperatures were monitored, one probe was placed in the channel, between the capacitor plates, and the other probe was placed nearby in a draft-free area. The temperature differences recorded during RF exposures did not exceed those measured in control runs (i.e. between the chamber and room, without RF).

D. Microscopy - Measurement of Streaming Rates

The chamber with a mounted internode was clamped in place under a Bausch and Lomb monocular microscope from which the stage had been removed. The support structure to which the chamber was clamped was independent of the microscope so that the latter

could be moved, without disrupting the cell or the intracellular pipette, from area to area along the length of the cell. In this way, both irradiated and unirradiated regions of the cell could be observed during intracellular recording.

Light from a small lamp passed through a CuSO_4 heat filter before being reflected up into the chamber. Observations were made at 63X (6.3X high working distance objective, 10X ocular). Streaming rates were measured with the aid of an ocular micrometer and hand-held stopwatch by averaging the timed passage of several similar sized organelles.

RESULTS

OVERVIEW

An overview of the streaming and membrane electrical responses of Nitella cells exposed to radiofrequency radiation of 0.5 Hz to 2.5 GHz, maximum field strengths of 50 v/cm, is presented in Table III. Likewise, a description of the response of Nitella to 3 types of control stimuli (excitatory electrical stimulus pulse, repetitive excitatory pulses, and static electric fields) is provided for general comparison. Microscopic observation of the cytoplasmic streaming in cells exposed to RFR sometimes revealed patterns of particle movement not seen in normal control cells.

It is apparent that the cellular response to RFR falls into two distinct categories:

1. Membrane hyperpolarization and small increases or undetectable changes in streaming rate at frequencies from 100 KHz to 2.5 GHz; and
2. Membrane depolarization and inhibitory effects on streaming at frequencies below 100 KHz.

These results are presented in detail below, following the description of the responses of Nitella to control stimuli.

TABLE III. THE GENERAL ELECTRICAL AND STREAMING RESPONSES OF NITELLA EXPOSED TO RADIOFREQUENCY RADIATION OF 0.5 Hz - 2.5 GHz.

Electrical Stimulus	Cell Response		Streaming Recovery with continued exposure
	Electrical	Streaming	
Pulse, V_{th}	Action Potential	abrupt cessation	N.A.
Repetitive Pulses, V_{th} (rep)	Action Potential	abrupt cessation	N.A.
Static Electric Field	-	slowing and subsequent death	No
RFR (0.5 Hz - 10 KHz)	Action Potential or depolarization	slowing to cessation	Yes
RFR (100 KHz - 2.5 GHz)	no change or hyperpolarization	no change or slight increase in rate	Yes

I. THE RESPONSE OF NITELLA TO CONTROL STIMULI

A. Membrane and Streaming Response to an Electrical Stimulus Pulse

The recorded action potentials in cells stimulated by a superthreshold pulse were always accompanied by the abrupt cessation or inhibition of streaming, as previously described (Hill, 1941; Kishimoto and Akabori, 1959; Tazawa and Kishimoto, 1968). The shape of the action potential could change for a given cell and stimulus, even after the cell potential had recovered to its resting level (c.f. Findlay, 1959), although the threshold stimulus required for excitation did not change (Tazawa and Kishimoto, 1964). Biologically inherent variability between the cells resulted in V_{th} values ranging from 0.16 to 5.9 volts across the capacitor plates. The resting potential and action potential height of the various cells were extremely consistent, averaging -125 mv and 57 mv, respectively.

Subthreshold stimulus pulses typically had no effect on the cytoplasmic streaming, although some cells did show temporary and slight slowdowns. The decrease in streaming in these cells could appear as: 1) the transient slowing of a few isolated particles within the otherwise unaffected flowing endoplasm; 2) the slowing of a longitudinal band of flowing endoplasm which might spread to include more of the flow; or 3) the general slowing of all the cytoplasm along the entire cell or in localized areas (Fig. 5).

Figure 5. Patterns of the Slowdown of Streaming Observed
in Cells Exposed to Subthreshold Stimulus Pulses.

The length of the arrows represents the velocity of the
endoplasmic particles.

- a). Transient slowing of isolated particles
- b). Slowing in longitudinal bands
- c). General localized slowing

The patterns represented are those seen looking down on the
cell, focused on a single optical plane.

Normal Flow

Inhibited Flow

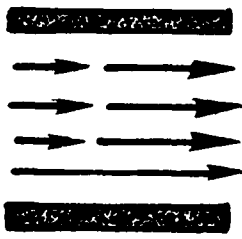
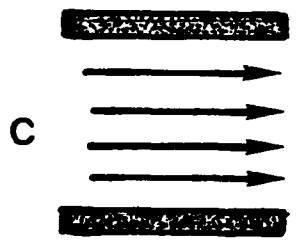
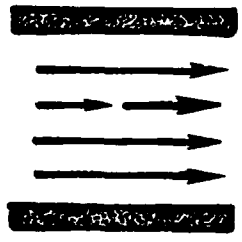
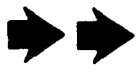
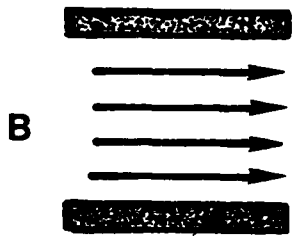
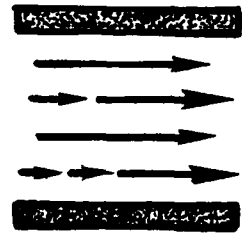

B. Membrane and Streaming Response to Repetitive Stimulus Pulses

An action potential and streaming cessation could be obtained by repetitive pulses of subthreshold stimuli of sufficient magnitude. This threshold value for repetitive stimuli, $V_{th} (rep)$, varied from cell to cell. $V_{th} (rep)$ was frequency independent for pulse rates of 40-200 Hz; that is, the minimum voltage needed to excite the cell was constant for the different repetition frequencies. Repetitive stimuli at voltages below $V_{th} (rep)$ had little or no effect on the streaming rate. During the period of repetitive stimulation, no action potentials were seen; the time for the onset of action potentials after the end of stimulation was extremely variable, so that no generalizations relating time of onset to frequency or length of stimulation could be made. One cell showed spontaneous action potentials after exposure to repetitive pulses of high frequency, presumably due to a voltage supersensitivity of that particular cell (c.f. Kishimoto and Akabori, 1959). Following 3-5 minutes of rest after exposure to repetitive stimuli, the cells were again excitable by a pulse of their original V_{th} .

C. Streaming Recovery After the Cessation of Cyclosis

The resting streaming velocities of Nitella used here varied between cells (45-80 $\mu\text{m/s}$) but remained constant for a given cell under the same conditions. In normal cells, streaming which had been halted due to an action potential remained stopped for a few seconds before movement first began. Figure 6 shows the recovery

Figure 6. The Recovery of Cytoplasmic Streaming After Cessation
By a Superthreshold Stimulus Pulse.

The ordinate is given in terms of relative recovery of streaming velocity, with 100% representing the resting rate. The arrow indicates the application of the stimulus. The cell was excited every 15 minutes. The slope of the recovery curve remains constant for each action potential induced cessation.

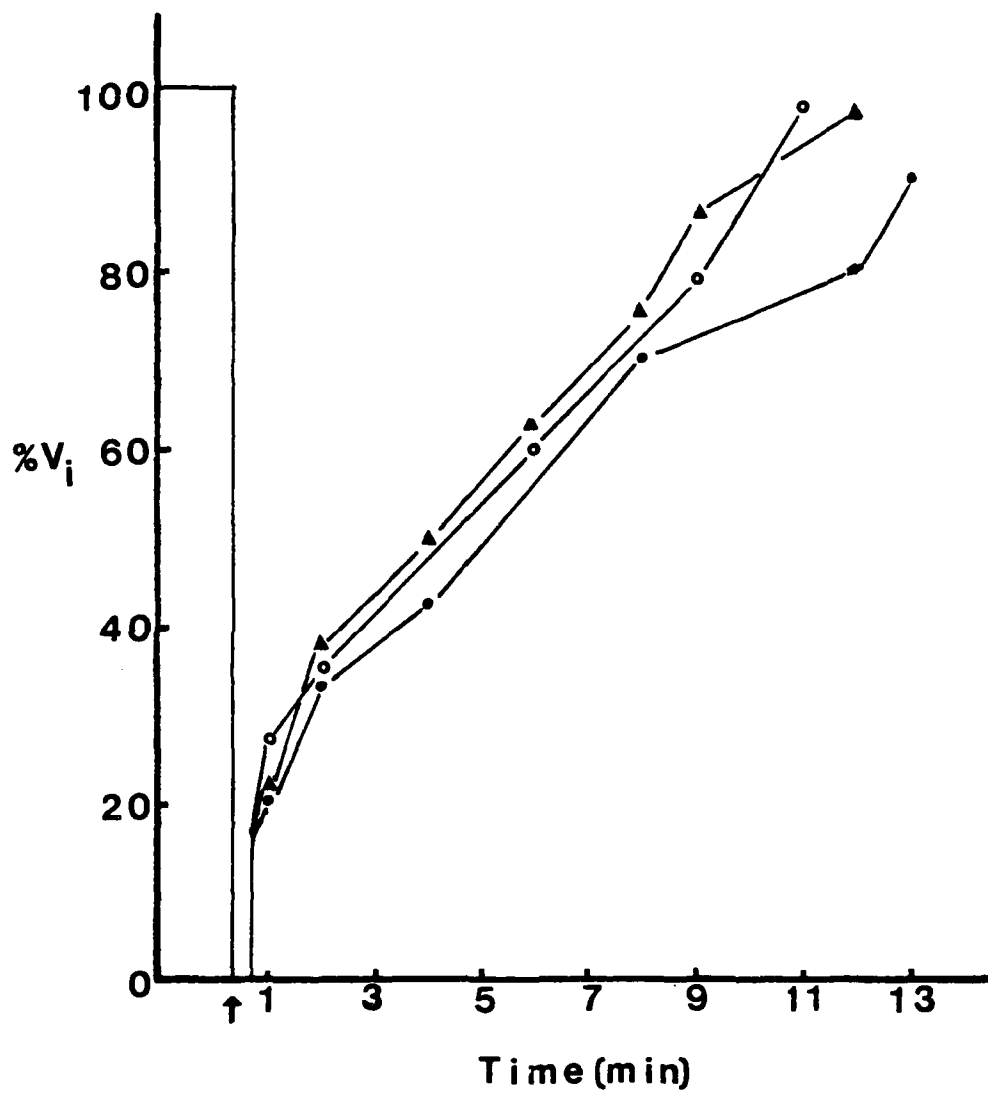

of streaming in a cell stimulated by a pulse of its V_{th} every 15 minutes. The slope of the streaming recovery curve varied for different cells, but it remained the same for a given cell and stimulus.

D. Streaming Response of Cells Used During Winter Months

Internodes used during winter months often showed deviations from the normal action potential response. This abnormal behavior is attributed to the seasonal decrease in vitality known to occur in these cells (Allen, personal communication). Instead of the expected cessation of streaming in the entire cell, the response of winter cells stimulated by V_{th} was often a halting of cyclosis in the irradiated areas, with continued streaming in the rest of the cell. Application of a second V_{th} pulse or a pulse of greater intensity effectively stopped all streaming, however, not without dramatically prolonging the streaming recovery time or plasmolyzing the cell. Cessation and inhibition in these cells was similar to that previously described for some subthreshold pulse stimuli (that is, uneven or banded), although the effects seen in these cases were much more pronounced. Cells which displayed this type of behavior were of questionable health and, therefore, not used for RFR experiments.

E. Response to Static Electric Fields

Figure 7 shows the streaming response of a cell exposed to nonlinearly increasing strengths of static electric field. While the specific moment to moment variation in streaming rate was

Figure 7. The Streaming Response of a Cell Exposed to a Static Electric Field of Increasing Strength.

The streaming rate became erratic and uneven after exposure of the cell to a static electric field of subthreshold intensity. A second exposure resulted in the slow decline of streaming rate and eventual cell death. The ordinate again represents streaming velocity as a percentage of the initial rate. The cell did not recover under continued exposure.

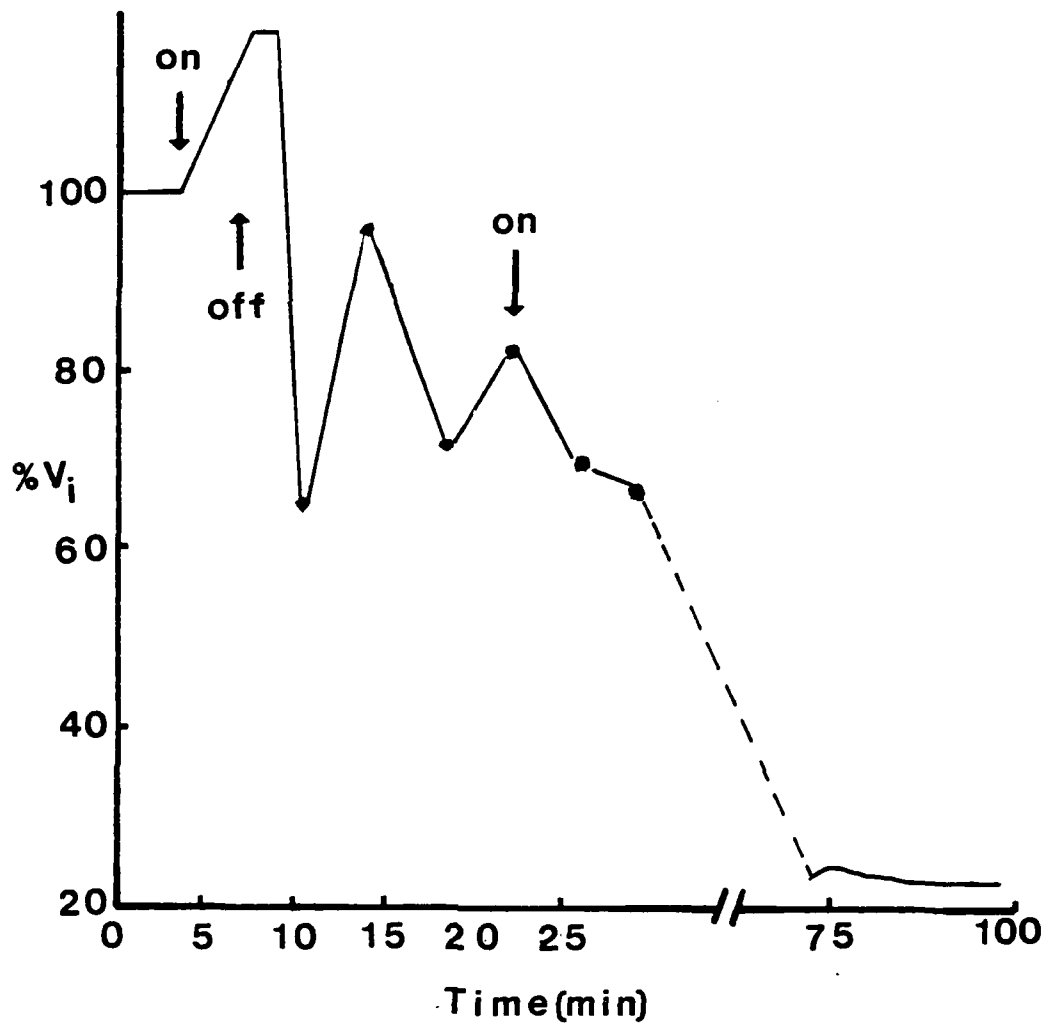

different for each cell and for different areas along the length of an individual cell, several streaming responses were common to all internodes exposed in this manner:

1. Streaming was first affected in the irradiated area;
2. Streaming effects were often uneven, with particles showing differences in velocity (from 0 $\mu\text{m/s}$ to 80 $\mu\text{m/s}$) from area to area along the cell length;
3. Streaming did not show recovery under constant exposure;
4. Streaming never showed an abrupt cessation or inhibition, even at field strengths greater than the cell's V_{th} .

Cells in which cyclosis had been drastically affected by static electric fields did not recover after exposure, as evidenced by the disarray of the chloroplast rows and later plasmolysis.

II. NITELLA RESPONSE TO RADIOFREQUENCY RADIATION

A. Streaming Response and Its Frequency Dependence

The streaming alterations due to RF exposures of 0.5 Hz to 2.5 GHz ranged from cessation of cyclosis to slight transient increases in rate. Figure 8 shows the frequency-response relationship for a number of cells exposed to RFR. The field strengths used varied for each particular cell, being either the minimum peak to peak voltage (V_{pp}) seen to stop streaming or the maximum intensity of V_{pp} available. As mentioned previously, field strengths at RF's above 1 MHz could not be measured, and

Figure 8. The Frequency-Response Relationship of Nitella
Exposed to a Range of Radiofrequencies.

The cut-off frequency for RF induced streaming cessation
is ca. 10KHz.

- Streaming cessation
- Streaming inhibition or slowdown
- Streaming acceleration
- No change

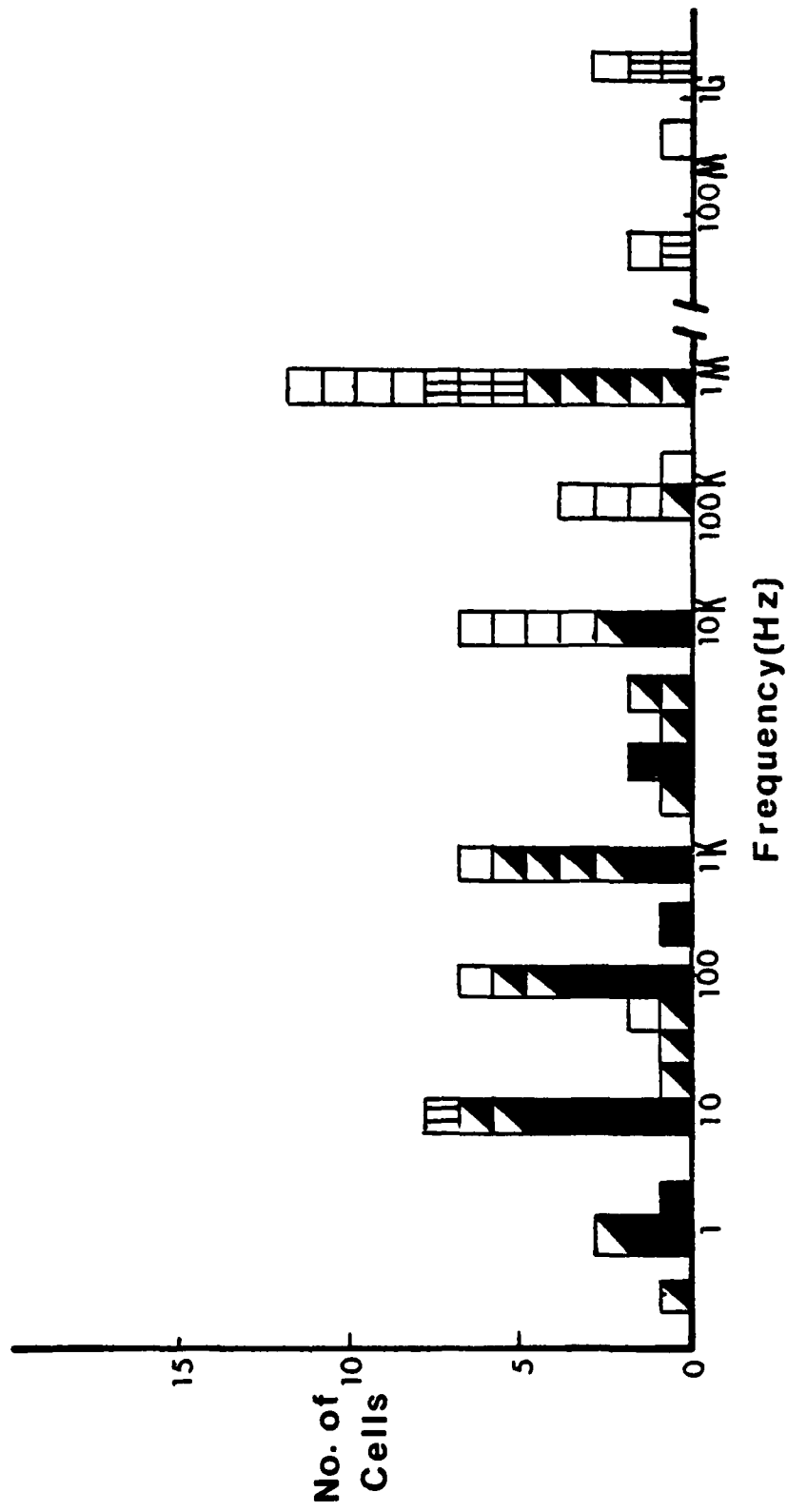

cells irradiated by these frequencies were exposed to the maximum, unattenuated Vpp output of the generator. It was evident, nevertheless, that at frequencies above 10 KHz, inhibition or cessation of streaming was unlikely to occur.

At frequencies from 100 KHz - 2.5 GHz, the cessation of streaming was never observed. During preliminary experiments, streaming cessations similar to those reported by Straus (1979) were seen in cells irradiated by RF up to 1 MHz; however, those cessations were later determined to have resulted from a large, transient stimulus artifact. The switch which was later added in series with the RF generator output effectively eliminated the artifact and the corresponding streaming cessations. Most cells exposed to RF above 100 KHz showed no changes in their streaming rates. Slight transient increases in rate occurred upon the application of RF above 1 MHz in 37% of the cells. In 3 out of 13 of the 1 MHz irradiations, the streaming rate decreased to ca. 74% of the original velocity after the end of the exposure (i.e. an "off response").

The streaming responses to RFR below 100 KHz were entirely separate from those described to occur at higher frequencies. Irradiations of 0.5 Hz to 10 KHz elicited action potentials and streaming cessation or caused drastic slowdowns in streaming rate. Figure 9 illustrates the frequency dependence of the ratio of Vpp (the peak to peak RF voltage necessary to halt cyclosis) to Vth (the minimum voltage of stimulus pulse to halt streaming). The best-fit linear slope shows Vpp/Vth increased slightly with

Figure 9. The RFR Frequency Dependence of the Voltage Necessary for Excitation of Nitella.

V_{pp} = Peak to peak voltage for RFR induced cessation of streaming

V_{Th} = Threshold voltage for excitation by a control stimulus pulse

The ratio, V_{pp}/V_{Th} , increases with increasing frequency of RFR irradiation; that is, at higher frequencies, the relative voltage necessary for excitation is greater.

correlation= 0.18

coefficient of best linear fit= 0.12

constant term= 1.05

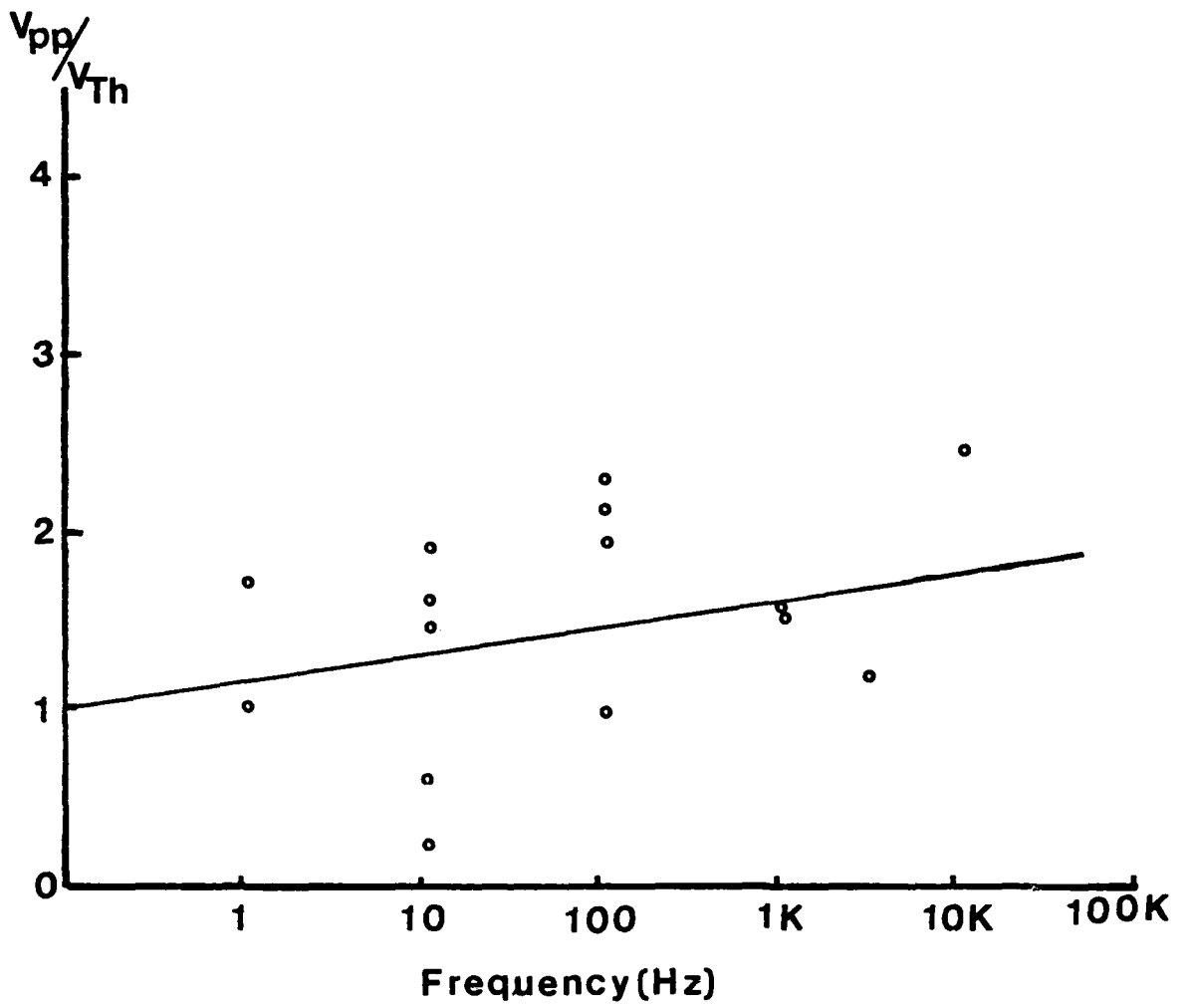

increasing frequency; in other words, at higher frequencies, greater relative voltages were needed to excite the cells.

The streaming cessations due to RFR were qualitatively different from those caused by control pulse stimulations; that is, V_{th} induced cessations were abrupt and involved the entire cell, while RF induced cessations often appeared as a rapid (2-3 sec.) slowing of cyclosis to a halt. RF induced streaming inhibitions or slowdowns appeared as general, cell-wide decreases in rate or as uneven, localized retardations, similar to the streaming patterns seen in cells exposed to static electric fields.

B. Streaming Recovery After Exposure to RFR

Streaming which had slowed or stopped due to RF exposure recovered to its normal rate under continued RF in 87% of the cells. Table IV lists, according to frequency of RFR, the percentage of cells which were seen to recover while being continuously exposed to radiation. Figure 10 shows the streaming recovery in a cell irradiated with 1 MHz after streaming had been stopped by a pulse of V_{th} . The slope of recovery is no different from that seen under control conditions.

Cells which were allowed to recover normal streaming in the absence of an RF field showed little change in the slope of their streaming recovery curves, although at frequencies below 10 KHz, the recoveries could be less steady. Figure 11a shows the recovery curve of a cell which had previously shown a streaming inhibition during exposure to 5 KHz. The recovery from a

TABLE IV. INCIDENCE OF STREAMING RECOVERY DURING CONTINUED EXPOSURE TO RFR. CELLS INCLUDED IN THIS TABLE SHOWED STREAMING SLOWDOWN OR CESSATION AT THE GIVEN FREQUENCY OF RF AND RECOVERED NORMAL RATES UNDER CONSTANT IRRADIATION.

Frequency of the Irradiation (Hz)	Total Number of Cells Examined *	% of Cells Which Recovered Normal Streaming
1	1	0
4	1	100
10	3	67
20	1	100
100	2	100
1 K	2	100
2 K	1	100
5 K	1	100
100 K	1	100
1 M	2	50

* small sample size is due to the paucity of available, healthy cells

Figure 10. Streaming Recovery During Irradiation By 1MHz

Coordinates have been previously defined.

- =Recovery after control stimulation
- ▲ =Recovery during 1MHz irradiation
- =Recovery after subsequent control stimulation

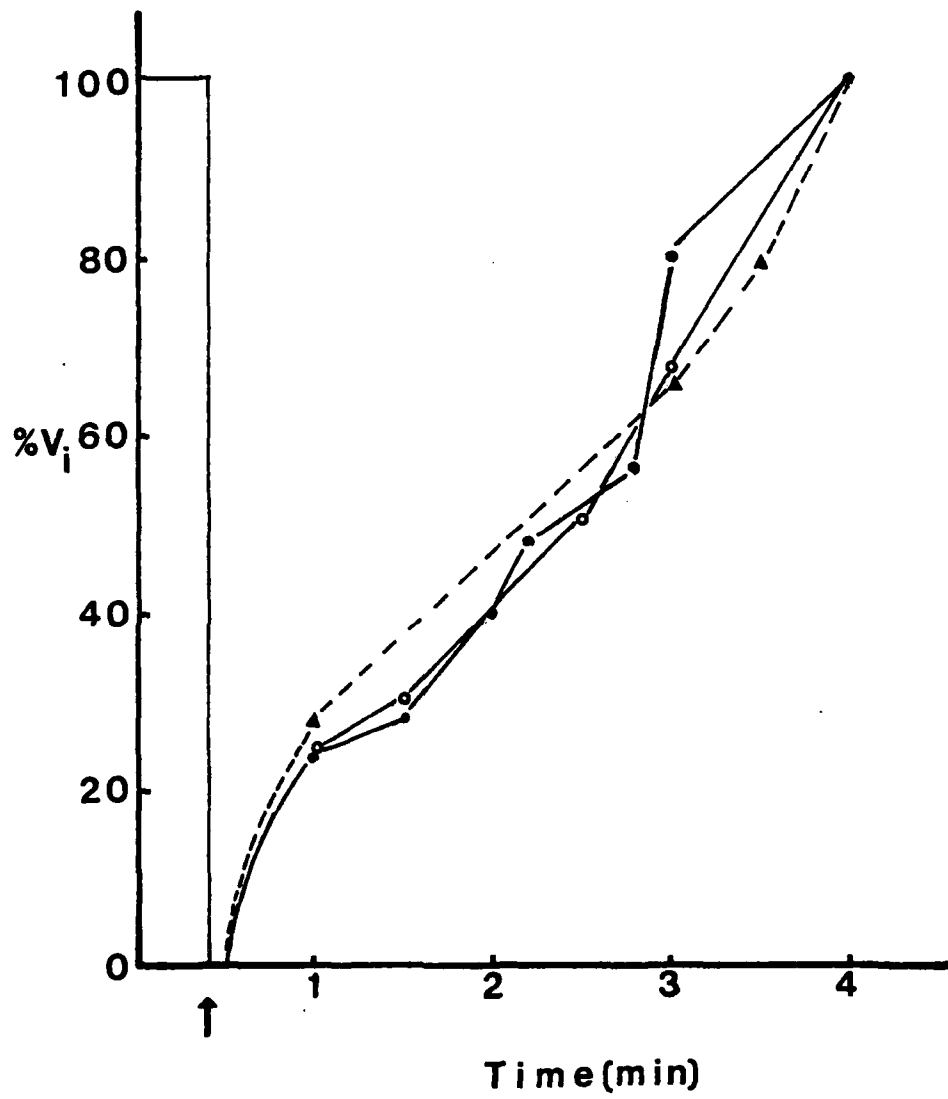

subsequent V_{th} -induced cessation is seen to be erratic, although of generally the same slope, when compared to the pre-irradiation recovery curve. The same cell was later exposed to 10 KHz and, after showing no streaming response due to the RFR, stimulated with V_{th} . The recovery from this streaming cessation was the same as that seen in the control run. Figures 11b,c, and d show the curves of streaming recovery in cells irradiated with higher RF's and then excited with a pulse of V_{th} . Again, no RF effects were seen on the ability of the cell to recover normal cyclosis.

C. Membrane Response to Radiofrequency Radiation

The general membrane response to RFR is shown in Table V and described here in detail.

1. RESPONSE TO FREQUENCIES GREATER THAN 1 MHz

No change in membrane potential or later excitability was seen in the cell exposed for 5 minutes to 2.5 GHz. In the other 5 cells irradiated by RFR between 60 MHz and 2.5 GHz, no changes were observed in the ability of a pulse of V_{th} to halt streaming.

2. HYPERPOLARIZING RESPONSE TO FREQUENCIES OF 100 KHz - 1 MHz

100 KHz irradiation at a field strength 20 times greater than the cell's V_{th} resulted in a 2 mv hyperpolarization of the membrane. After the exposure, the cell was unresponsive to a pulse stimulus of V_{th} for ca. 15 minutes. The action potential elicited by a subsequent V_{th} pulse appeared normal and was accompanied by streaming cessation in the entire cell.

Figure 11. Streaming Recovery After Irradiation By RFR.

Coordinates have been previously defined.
Cells were exposed to the given frequency, then excited
by a superthreshold stimulus pulse. The slope of the
recovery curves before and after exposure are the same.
t = time, in minutes; --- = recovery from control stimulus

- a. .----- = 5KHz
- = 10KHz
- b. .----- = 1MHz
- c. .----- = 99MHz
- d. .----- = 2.5GHz

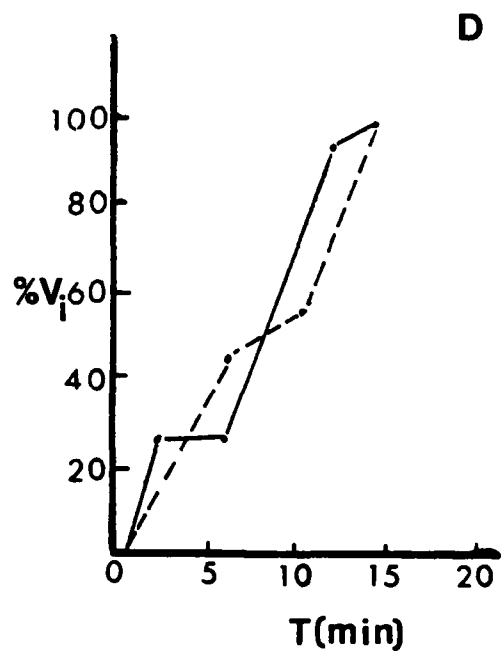
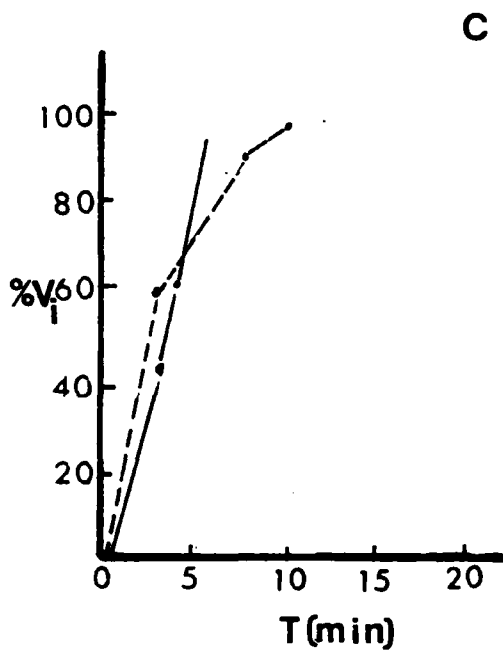
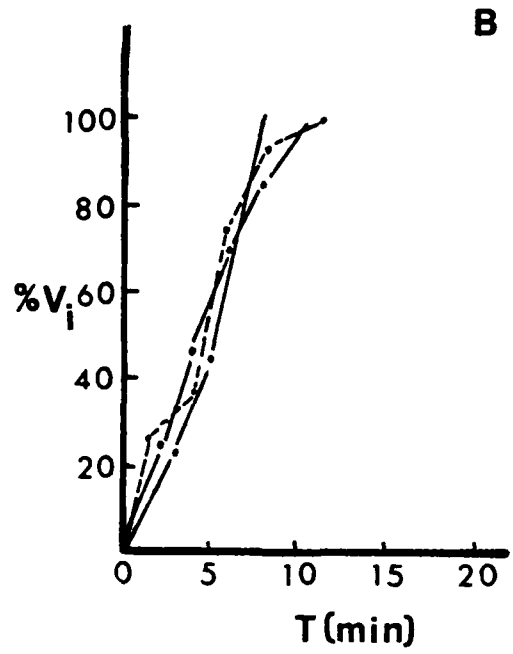
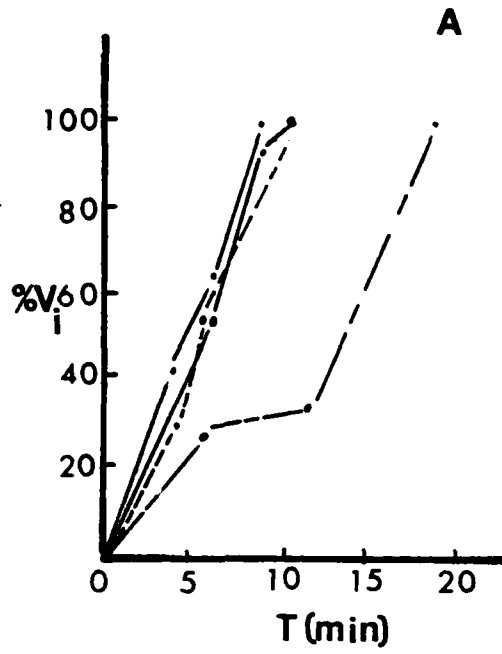

Table V. GENERAL ELECTRICAL RESPONSE OF NITELLA EXPOSED TO RADIOFREQUENCY RADIATION.

Frequency of the Irradiation (Hz)	Total Number of Cells Examined	Membrane Electrical Response	Effect on Later Excitability*
50	1	depolarization	-
100	1	depolarization	No
1 K	2	depolarization	No
100 K	1	hyperpolarization	Yes
1 M	5	hyperpolarization	Yes
2.5 G	1	no change	No

* as evidenced by the prolonged inability of a threshold stimulus pulse to elicit an action potential.

In the 5 cells that were intracellularly monitored while exposed to 1 MHz, the cell resting potentials showed either no change or hyperpolarizing offsets of a few millivolts. Hyperpolarized membranes returned to their normal level in 2-5 minutes after the end of the irradiation. Subsequent 1 MHz irradiation resulted in an offset smaller than that observed upon initial exposure (Fig. 12).

In 3 of the cells, streaming rate remained constant or slightly increased during the 1 MHz exposure. There was no change in the ability of a subsequent pulse of V_{th} to elicit an action potential.

The streaming rates in each of the 2 remaining cells decreased slightly in the areas exposed to 1 MHz; the streaming in the rest of the cell remained unaffected. After the end of the irradiation, one cell could not be excited by a pulse of the original V_{th} value for ca. 25 minutes. The second cell showed a normal action potential response to V_{th} after it had been irradiated, although the streaming stopped only in the area of the cell which had not been exposed to RFR. The next action potential from a pulse of V_{th} resulted in the normal streaming response; that is, cessation along the entire length of the cell.

3. DEPolarizing RESPONSE TO FREQUENCIES OF 50 Hz - 1 KHz

Irradiation of 50 Hz caused a transient depolarization and slow down of streaming in the cell immediately upon application (Fig. 13a).

Figure 12. Hyperpolarizing Response to 1 MHz Irradiations.

The cell resting potential, ϕ , is -150 mv.
The membrane became hyperpolarized upon the application
of 1MHz. The subsequent irradiation resulted in a smaller
membrane response. The ordinate shows the cell potential
in millivolts(mv).

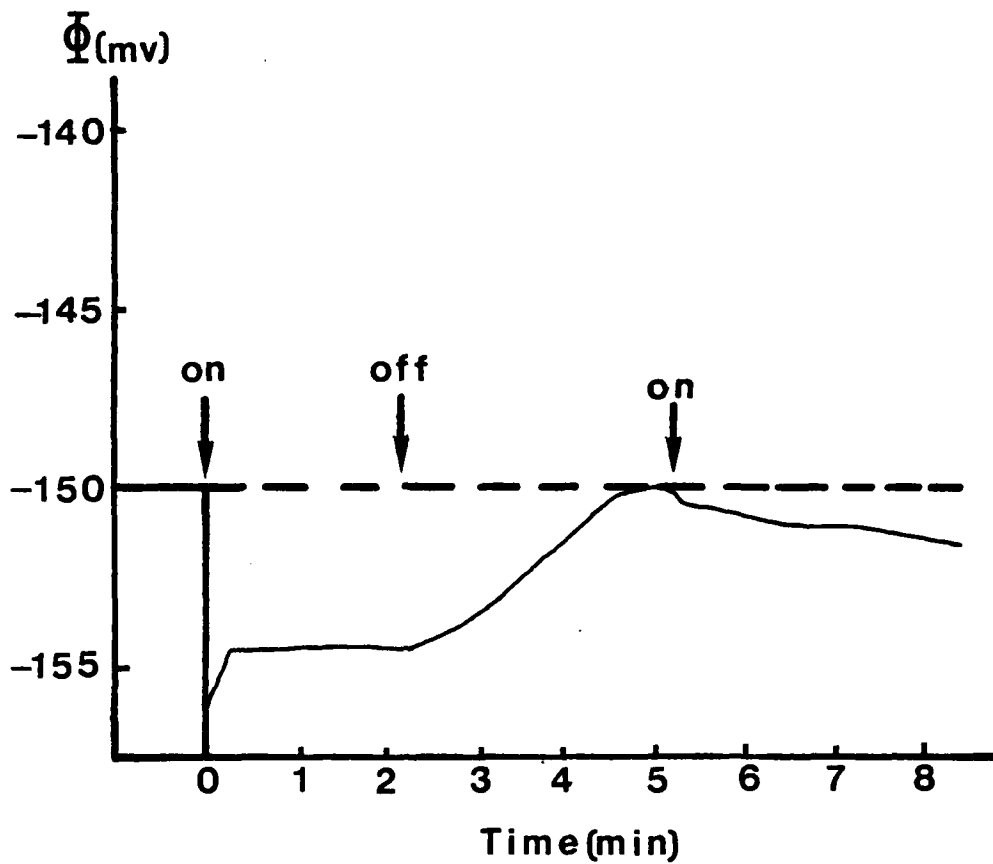

In a second cell, the termination of 100 Hz irradiation showed the cell potential to be depolarized to a level greater than the height of the average action potential. The potential quickly fell to a level $+35$ mv with respect to the resting potential and, within 3 minutes, reached the resting level. Figure 14a is a representation of this response.

The same cell was exposed to 1 KHz, maximum field strength. The irradiation caused a 20 mv depolarization, which recovered after power was turned off (Fig. 14b). In another cell exposed to 1 KHz, the cell was depolarized by 30 mv for the duration of the irradiation and remained at this level for the rest of the experiment (Fig. 13b). The depolarization may be attributed to stimulus artifact. The termination of exposure resulted in an "off response" of an action potential and streaming cessation (Fig. 13c).

Cells in which streaming had been halted or drastically slowed by 100 Hz or 1 KHz fields showed no changes in their later excitability by a pulse of V_{th} (i.e. streaming stopped in the entire cell) if stimulated after 3-5 minutes of rest.

D. 1 MHz Irradiation of Cells Rendered Inexcitable by $MnCl_2$

When $MnCl_2$ is the sole electrolyte in the bathing medium of Nitella, the cells are inexcitable (Barry, 1968). The reason for the failure of this solution to preserve membrane excitability is unclear, although it may be due to the dissimilarity of Mn (a

Figure 13. Intracellular Responses to 50Hz and 1KHz Irradiations.

The coordinates have been previously defined. Time marks each represent 12 seconds. The cell resting potential was initially -120 mv.

- a. 50Hz irradiation resulted in transient membrane depolarization and streaming slowdown.
- b. When the same cell was exposed to 1KHz, the potential was depolarized by 30 mv and remained at that level. The depolarization may have been through stimulus artifact.
- c. Power off of 1KHz resulted in an "off response" of action potential and streaming cessation.

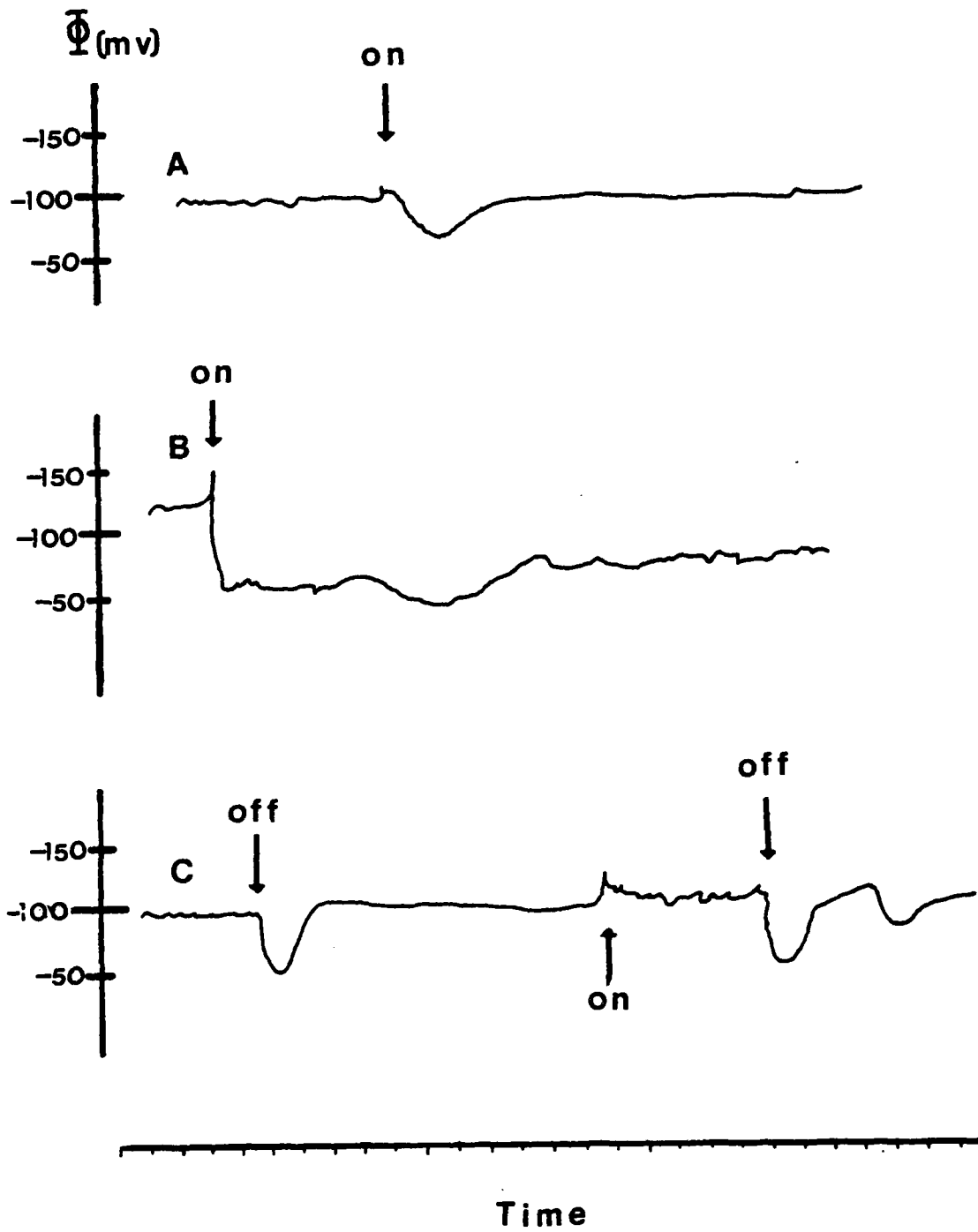
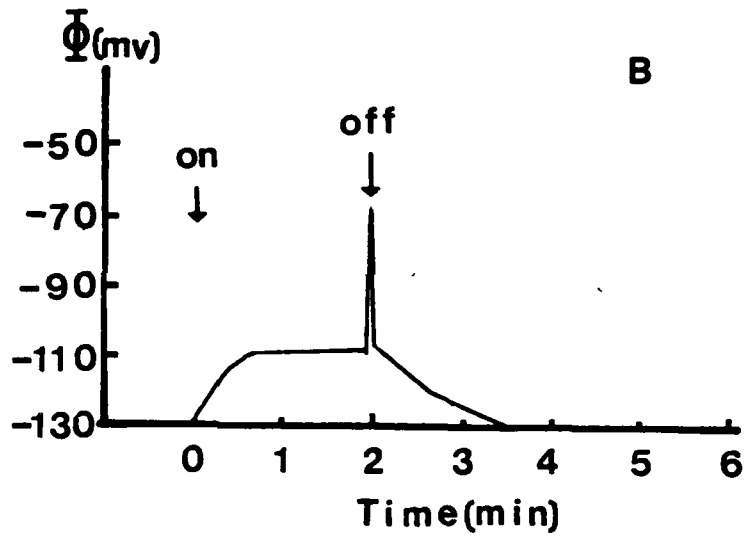
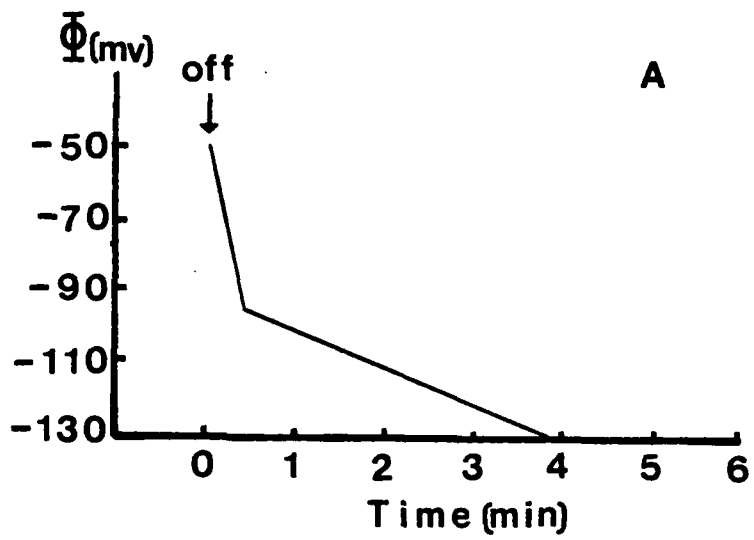

Figure 14. Intracellular Response to 100 Hz and 1 KHz RFR.

The coordinates have been previously defined.

- a. Termination of 100 Hz exposure showed a membrane depolarization, which declined to the resting level.
- b. Exposure to 1 KHz depolarized the membrane for the duration of the irradiation.



transition element) from the alkaline earth cations, Ca, Ba, Sr, and Mg, which can maintain excitability.

Cells in $MnCl_2$ continued streaming normally when they were given a stimulus pulse several times greater than their V_{th} . Later perfusion of the cells with Artificial Pond Water (APW) restored the membrane excitability, as evidenced by the abrupt cessation of streaming upon stimulation by a pulse of V_{th} . The pattern of cessation in some of these cells, however, appeared uneven and banded - similar to the type of streaming response described earlier for some cells irradiated with 0.5 - 10 KHz (see Fig. 5).

When cells in $MnCl_2$ were irradiated with 1 MHz, maximum field strength, the streaming responses varied from no change (2 cells), to a slight transient increase (1 cell), to a slight transient decrease (1 cell) in rate. Two cells showed slight decreases in the rate of cyclosis after the end of RF exposure.

DISCUSSION

OVERVIEW

The responses of isolated Nitella internodes exposed to RFR are in good agreement with theoretically predicted RF interactions with excitable cells. As described further on in Sections II and III, the observed RF effects on the membrane potential and streaming of Nitella are separated into two clearly distinct frequency regions. At low radiofrequencies, RFR acts on the cell via direct electrical stimulation. The upper frequency limit for this response is largely determined by the electrical properties of the membrane. At higher frequencies of RFR, the observed cellular responses can be attributed to thermal origins. Delays in the return of excitability to a pulse of V_{th} are attributed to the RF induced membrane hyperpolarization.

No RF induced effects on the cytoplasmic streaming in Nitella were observed that cannot be attributed to the electrical state of the membrane or thermal interactions. Microscopic observation of the streaming in cells which were exposed to RFR did not disclose any evidence of direct action by the radiation upon the molecular force generating mechanism. The observations did provide evidence of an RF induced perturbation of macromolecular interactions at the cell surface (Section IV).

I. DETERMINATION OF THE NATURE OF RF INTERACTION - THERMAL OR ATHERMAL?

Delineation of RFR interactions with biological systems requires the separation of the thermal and athermal components. Thermal effects are those which can be attributed to the normal biological response to increased heat. An effect is athermal if the electric field or accompanying magnetic field of the radiation interacts at a molecular or macroscopic level, without depending on the generation of heat (Schwan, 1971). For an RF effect to be classified as "athermal" or "direct", then, it must be shown (Pickard and Barsoum, 1981) that:

1. The observed response cannot be explained as behavior predicted to occur in response to RF induced heating.
2. A model which does not depend on the thermal agitation of molecules for its operation can be proposed to explain experimental fact.

Thermistor recordings made during irradiation experiments showed no RF induced heating of the bathing medium. It is possible that temperature changes below the level of detection or specific heating of the internode might have occurred, so that thermal effects cannot be ruled out. Comparison of the observed cellular responses to RFR and the known Nitella responses to increased temperature, however, can give a good indication of the thermal or athermal origin of any observed effect. It is, therefore, necessary to briefly report the known temperature (T) dependence of the two parameters measured in this work, the streaming velocity and the membrane potential (Fig. 15).

Figure 15. The Variation of Streaming Velocity and Membrane Potential with Changes in Temperature.

Increasing temperatures result in acceleration of streaming velocity and hyperpolarization of cellular potential.

- a. Streaming velocity(v , in $\mu\text{m/s}$)
(from Pickard, 1974)
- b. Vacuolar potential(Φ , in mv)
(from Hogg, et. al., 1968)

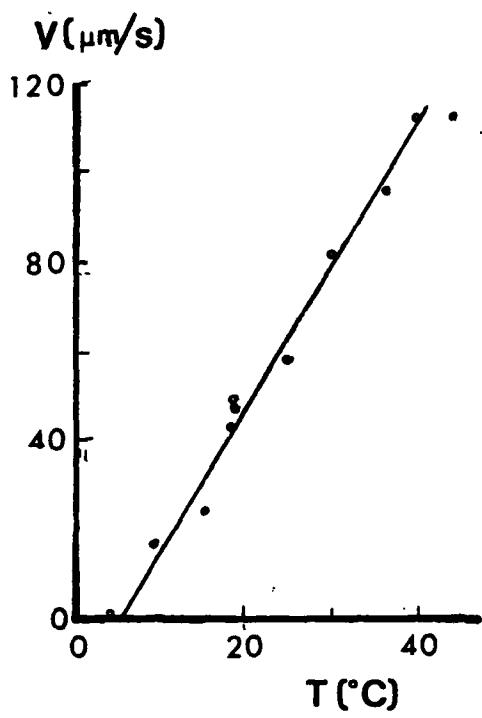

A

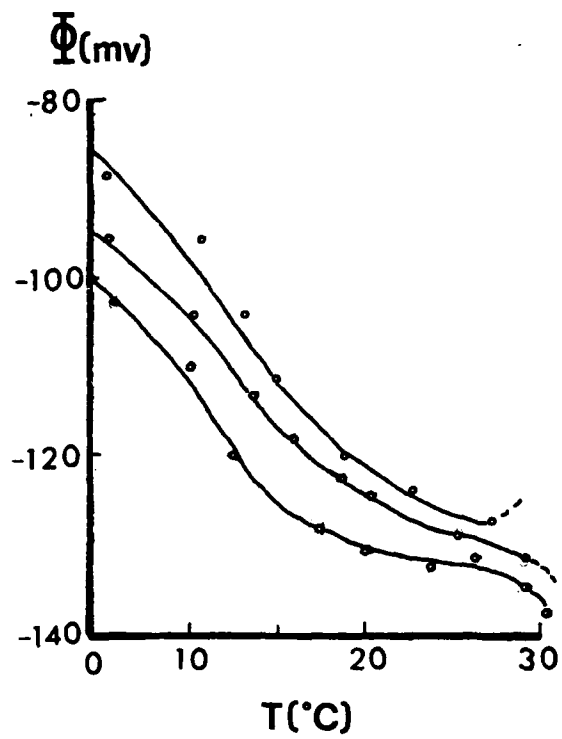

B

Investigations of the variation in streaming rate with T (Hayashi, 1960; Pickard, 1974) show a linearly increasing streaming velocity with temperatures from 0° to 30°C (Fig. 15a). The membrane potential similarly shows a linear dependence on T, becoming increasingly negative with rising temperature from 0°-18°C (Fig. 15b). Above 18°C, the potential varies less regularly with increasing T, but it generally decreases or remains stable between 20°-25°C (Hogg, et. al., 1968; Hope and Aschberger, 1970).

From these established variations in streaming and membrane potential associated with increases in temperature, it is possible to divide the RF induced effects seen in this study into two general groups:

1. Effects observed at frequencies above 100 KHz (streaming acceleration and membrane hyperpolarization) which are in accordance with responses expected to occur from RF heating; and
2. Effects observed at frequencies below 10 KHz (streaming inhibition and membrane depolarization) which are contrary to those expected from RF induced heating.

These two groups are discussed separately and in detail below. A model, based on observed RF induced alterations in cytoplasmic streaming, which proposes a molecular mechanism of calcium mediated streaming control is also presented.

II. CELLULAR RESPONSES TO FREQUENCIES ABOVE 100 KHz - MECHANISMS OF RF INTERACTION

A. Thermally Induced Effects

Most of the effects of RFR between 100 KHz and 2.5 GHz on the membrane potential and cytoplasmic streaming of Nitella are in accord with cell responses which can be predicted to occur as a result of RF heating (see Fig. 15) or which have been previously reported (Pickard and Barsoum, 1981; Liu, et. al., 1982). Pickard and Barsoum observed membrane hyperpolarizations of ca. 0.5 mv in both Chara and Nitella exposed to RF of 200 KHz - 10 MHz, 100 v/cm. The hyperpolarizations measured in cells exposed to 100 KHz - 1 MHz, 50 v/cm in the present work are of greater magnitude than those described by Pickard and Barsoum; the difference is attributed to variations in exposure methods. In the present work, approximately 1/2 of each cell (10-15 mm) was exposed to RFR; in the previous investigation, only small (12.4 mm) lengths of internodes were irradiated.

The nature of the membrane response seen here remains to be determined. Both thermally and athermally induced hyperpolarizations have been reported in characean cells exposed to RFR (Pickard and Barsoum, 1981) and were distinguished by their rise times (the time constant of the thermal component being 1000X that of the athermal effect). No attempt can be similarly made here to distinguish between the two modes of RF interaction, although the coincident appearance of the two temperature dependent phenomena - membrane hyperpolarization and

increased streaming velocity - is evidence that the response might be at least partly of thermal origin. Indeed, field induced forces on the molecular or microscopic level are not likely to be significant at field strengths less than a few hundred v/cm (Schwan, 1971; Stuchly, 1979).

Pickard and Barsoum (1981) showed a cutoff frequency for membrane hyperpolarization of ca. 10 MHz; no offsets were detected at higher frequencies up to 50 MHz. Liu, et. al. (1982) later reported no change in resting potential or action potential characteristics in Chara irradiated with 2.5 GHz. In agreement with these results, no changes in the intracellular potential of the cell exposed to 2.5 GHz were detected. The transient increase in streaming velocity observed at this frequency of RF is again attributed to a thermal interaction.

B. Possible Athermally Induced Responses in Cells Exposed to 1 MHz

In two of the cells irradiated with 1 MHz, the streaming rate decreased slightly during the exposure, and the portion of the cell which had been irradiated was left temporarily inexcitable. A similar streaming response was seen in a cell which had been in a solution of $MnCl_2$. The mechanism behind this effect is undefined. One possible explanation for the transient slowdown of streaming could be a direct interaction of the RFR with the force generating machinery. Although such direct effects at the molecular level cannot be ruled out, they are theoretically unlikely to occur at the field strengths used here.

Further, that a similar streaming slowdown was observed in 2 of the $MnCl_2$ treated cells upon the termination of RF exposure is indication that the effect might not be due to RF exposure, itself, but rather to a subtle change in the electrical environment of the cell.

The observed effects, then, can be explained in terms of a field induced perturbation of the equilibrium potential gradient at the surface of the Nitella membrane (see section IV, presented later). In such a case, RFR causes a change in the electrical microenvironment around the membrane that allows the release of small amounts of calcium ion (which inhibits cyclosis) and prevents the normal functioning of the action potential machinery (which results in temporary membrane inexcitability).

III. CELLULAR RESPONSE TO FREQUENCIES BELOW 10 KHZ - DIRECT ELECTRICAL EXCITATION

It is shown here that RFR of frequencies up to ca. 10 KHz can directly excite the membrane of isolated Nitella internodes. For clarity, only the electrical aspect of the cellular response to radiation is now discussed. No attempt is made here to separate the streaming response seen in RF-exposed cells from that known to occur as a result of conventionally produced membrane excitation, although it is known that perfect coupling between excitation and streaming cessation does not exist (Kishimoto and Akabori, 1959; Tazawa and Kishimoto, 1964; Pickard, 1968).

The method by which RFR acts to excite the characean membrane can be understood in the context of previously defined membrane characteristics. In the resting state, the ion permeability and potential across a membrane are maintained by the passive electrostatic and diffusive forces which act across the protein channels embedded in the fluid lipid bilayer (Singer and Nicholson, 1972). The membrane conductivity, then, will be influenced by the movement of charge transporting ions in response to applied electrical potential gradients. When an RF field is applied to the membrane, the movement of these ions across the channels will be alternately aided and/or impeded. At high frequencies, the direction of the electrical gradient across the channel may change more quickly than the ions can move across the membrane (i.e. the transit time of the ions is greater than $1/2$ the frequency of the RF signal). For a given electrical potential gradient, then, the distance traversed by the ions will decrease with increasing frequency, until at some upper frequency limit the net effect of the RF field is to "dither" the charge transporters in place (Pickard and Barsoum, 1981).

The frequency above which the ions will be unable to fully transverse the membrane is defined by $f = 1/2t$ (f -frequency of RF, t -transit time of the ions). For Chara, t has been shown to be about 50 nsec, giving an upper frequency limit for RF induced changes in membrane conductance of $f = 10$ MHz (Pickard and Barsoum, 1981). The upper frequency limit for an RF induced membrane excitation, however, is much lower and is defined in terms of the membrane capacitance. The membrane capacitance (C)

is $1 \mu\text{F}/\text{cm}^2$ (Hope and Walker, 1975); the membrane resistance (R) is $40\text{-}50 \text{ K}\Omega\text{cm}^2$ (Tazawa, et. al., 1976). The electrical time constant of the cell is $T = RC$, or 50 msec; this corresponds to an upper frequency limit of ca. 10 Hz. In short, the membrane cannot instantaneously respond to a change in the potential gradient across its ion channels. If an alternating signal of a frequency in excess of 10 Hz is applied across the membrane, the signal will change direction before the membrane currents will be able to respond.

It is obvious from the results seen here, however, that the membrane does respond to RF's well in excess of 10 Hz. This can be understood in the context of the nonlinear current-voltage relationship of the Nitella membrane (Kishimoto, 1965). The membrane acts as a rectifier; that is, it is more conductive to depolarizing currents than to hyperpolarizing currents. Under alternating current conditions (for example, RFR), the membrane will allow the net passage of a depolarizing current. This rectification behavior is expected to be frequency dependent (Pickard and Rosenbaum, 1978), with a cutoff frequency on the order of 1 KHz (Pickard, personal communication). This theoretical prediction is in close agreement with the cutoff for excitation seen here, and it appears that the RF specific excitation of Nitella occurs by the same means as that achieved through conventional electrophysiological techniques, such as injected current or externally applied pulse stimuli.

Throughout this work, the magnetic component of RFR has been ignored. Blatt and Kuo (1976) showed that magnetic fields of up

to 2.0 telsa had no effect on the action potential or viability of Nitella cells exposed for periods as long as 72 hours. It appears, then, that biomagnetic effects from the RF fields used here are unlikely.

The RF-induced changes in the membrane potential and cessation of streaming do not appear to be unique to electric fields; however, subtle effects on the cellular electrical "machinery" due to RF exposure cannot be ruled out. The changing electrical gradients across the membrane at frequencies up to 10 MHz could very easily cause small perturbations in the normal electrochemical environment at the cell surface. And in fact, observations of the streaming responses to RF-elicited action potentials indicate the existence of a field induced modification of the calcium control mechanism. An insight into that control mechanism and a model of RF interaction with it follows.

IV. INSIGHTS INTO THE ELECTRICALLY ASSOCIATED CONTROL OF CYTOPLASMIC STREAMING - SPECULATIONS ON THE MECHANISM OF CALCIUM ION RELEASE

A. A Proposed Model of Electrically Induced Calcium Ion Release

Throughout the course of this work, the streaming response of Nitella exposed to various electrical stimuli was observed for the purpose of not only clarifying the action of RFR on an excitable cell, but also gaining insight into the mechanism behind the control of cytoplasmic streaming. As described previously, the cessation of the flowing endoplasm in cells

excited by an electrical pulse of superthreshold strength was abrupt and along the entire length of the cells; the cessation of streaming due to exposure to RFR was more often uneven and gradual. While hypothetical, and clearly speculative, a preliminary model of the coupling process between membrane excitation and the resultant calcium mediated cessation of streaming in Nitella can now be presented.

Figure 16 is a diagrammatic sketch of a small portion of the characean plasma membrane. The membrane domain contains an "action potential complex", APC (i.e. the collection of ions, proteins, and macromolecules which are involved in the control of membrane permeability during an excitatory event) and a calcium binding protein complex, BP, imbedded within the fluid bilipid layer (Singer and Nicholson, 1972). Extracellular glycoproteins with associated ions and charges stem from both complexes and serve to electrically define and maintain a specific distance and orientation between the APC and BP, which corresponds to an equilibrium configuration of greatest stability and lowest energy (Fig. 16a).

Upon excitation, the APC undergoes appropriate conformational changes to allow the selective flow of Cl^- and K^+ currents. These molecular changes of the APC perturb the electrical bond of Ca^{++} to the BP, causing the release of Ca^{++} and inhibition of cyclosis (Fig. 16b). The physical proximity of the APC and BP accounts for the long known association of the excitation event with streaming cessation, while the separation of the two complexes affords an explanation for the imperfect

Figure 16. A Model For RFR Perturbation of the Release of Calcium Ion From the Nitella Plasma Membrane.

BP = Calcium binding protein
APC= Action potential Complex

- a. Glycoproteins of the BP and APC define and maintain an equilibrium spacing configuration of greatest stability.
- b. Upon excitation, a conformational change in the APC results in the disruption of the electrical bond between the BP and calcium ion. The release of calcium halts cyclosis.
- c. In the presence of an electric field, the electrical environment of the glycoproteins is perturbed. The BP and APC then assume a new equilibrium spacing distance.
- d. Upon excitation, the resulting change in the conformation of the APC does not immediately cause the release of calcium from the BP. Streaming cessation could be delayed, uneven, or otherwise modified.

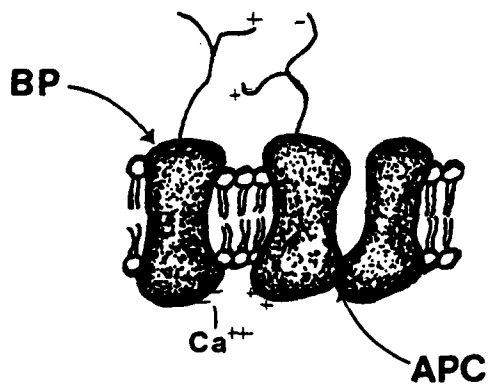

A

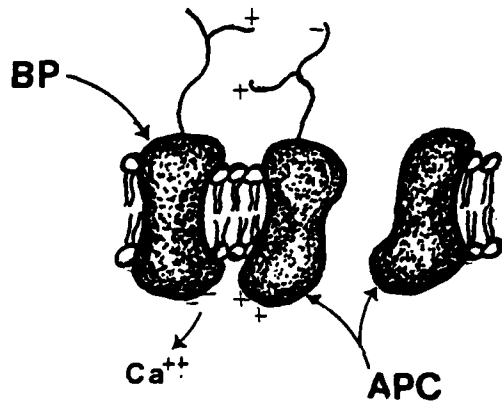

B

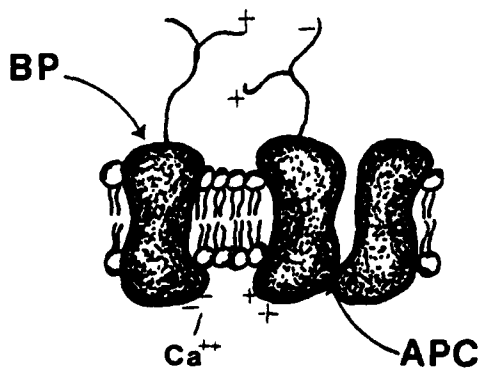

C

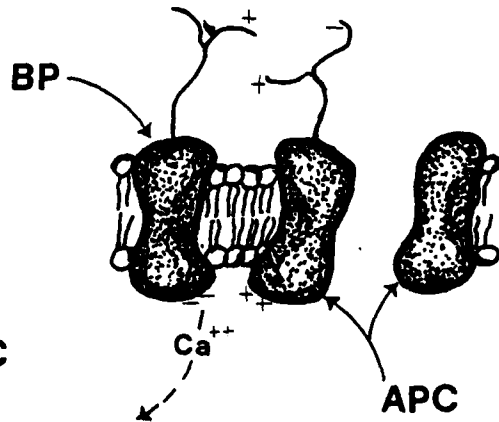

D

coupling between the two phenomena (Kishimoto and Akabori, 1959; Pickard, 1968).

In the presence of an RF field, the electrical environment around the glycoproteins may be modified in a way which would result in a new "lowest energy" spacing distance or configuration between the APC and BP (Fig. 16c). Upon excitation, then, conformational changes of the APC might not immediately affect the stability of the Ca^{++} -BP association, so that Ca^{++} release (and, therefore, control of cytoplasmic streaming) is either delayed or otherwise modified (Fig. 16d).

Two questions immediately arise in regard to this proposed mechanism of Ca^{++} ion release:

- 1) What is the biological basis for the hypothetical membrane model; and
- 2) Are the RF interactions described in the model likely to occur at the frequencies (0.5 Hz-10 KHz) and field strengths (0-50 v/cm) used here?

B. Biological Basis of the Model

Hayama et. al. (1979) proposed that the source of the Ca^{++} ions involved in the action potential induced cessation of streaming might be located at the plasma membrane. After the cessation of endoplasmic streaming, chloroplasts often continue to rotate in place (Hayama, et. al., 1979; personal observation) for a few seconds. Hayama, et. al. correlated the time interval between the start of electrical stimulation of the plasma membrane and the cessation of chloroplast rotation with the

distance of the chloroplast from the cortex; they concluded that, when excited, the plasma membrane might release calcium which first abruptly halts the cytoplasmic flow, then diffuses into the endoplasm to halt the rotation of organelles. While the authors did not discount the existence of a possible internal storage of Ca^{++} which could function much like the sarcoplasmic reticulum of muscle fibers, no such organelle has yet been described. In the meanwhile, it is not unreasonable to suggest that calcium ions are directly associated with some membrane component, rather than in putative endoplasmic storage sites. That calcium ion acts as an integral part of a plasma membrane bound transport system has been suggested by Lucas (1976), who found that the active HCO_3^- influx capacity of Chara was dependent upon extracellular calcium. Lucas proposed that in Ca^{++} free solutions, the cells' gradual loss of calcium from the plasma membrane might cause the deactivation of the membrane bound transport machinery for HCO_3^- . In this case, Ca^{++} per se acts as an integral component of the functional HCO_3^- transport system of the plasma membrane.

It is possible, then, that the BP of the model outlined here is the active transport system for bicarbonate ion. Some evidence exists which suggests a role of the HCO_3^- system in the control of cytoplasmic streaming. Williamson (1975) found that streaming recovery in perfused cells showed a pH sensitivity; at pH 8.0, reactivation of streaming never reached the normal level (which occurred at pH 7.0), and at pH 6.0 only "very low rates of movement" were seen. It remains to be shown if calcium induced alterations in streaming are accompanied with modifications in

the internal pH, due to the loss of Ca^{++} ion from the HCO_3^- transport system.

C. Are the Proposed Field Effects Likely to Occur?

What interactions between RFR and the membrane surface are likely to occur at the exposure conditions used during this work and considered in this model? Bawin, et. al. (1975) and Sheppard, et. al. (1979) have demonstrated an increase in Ca^{++} efflux from brain tissue exposed to weak, low frequency fields (less than 2.0 mw/cm^2 , 16 Hz) and attributed the effect to electric field induced cooperative interactions of glycoproteins on the outer cell surface. The electrical relationships between the various ions, polyanionic macromolecules, and glycoproteins at the cell surface could easily be affected by slowly undulating electric fields. In fact, the migration of membrane receptors in response to an electric field has been demonstrated in living cells (Poo and Robinson, 1977). Xenopus laevis embryonic muscle cells were subjected to electric fields of 4 v/cm and showed the reversible electrophoretic migration of fluorescently labelled concanavalin A receptors within 1.5 hours of exposure. While such long distance movements of membrane bound proteins are not expected at the exposure conditions used here, small shifts or alterations in the spatial arrangement of membrane macromolecules could very easily occur.

Theoretical support for RF action at the membrane surface can be found when the double dipole nature of the membrane is considered (Spiegel and Joines, 1973). In this case, the

membrane is pictured as a double layer of orderly dipoles on both the inside and outside surfaces, with the negative ends of the dipoles facing the intracellular and extracellular fluid, respectively. The resulting electrical gradients near the membrane surfaces would likely be very sensitive to externally applied fields. The existence of such surface-associated electric fields around characean cells has been shown (Nagai and Kishimoto, 1964), where external microelectrode measurements revealed unexplained variations of potential along the length of an internode.

D. Other Electrical Modifications of Ca^{++} Ion Release

The cessation of streaming due to RFR is qualitatively different from that normally induced by action potential. Some type of alteration in the electrically induced release of calcium ion might explain the observed patterns of streaming. From biological and electrical considerations, it appears that the Ca^{++} control of streaming which is typically associated with the occurrence of an action potential might not result from a change in membrane conductance or in the molecular mechanism regulating ionic flow (Pickard, 1968), nor in the change of the molecular environment of the electrogenic machinery (Tazawa and Kishimoto, 1964) per se, but rather, from a disruption in the electrical environment of the membrane bound HCO_3^- transport system.

Such perturbations of the electrical microenvironment of the cell could occur due to externally induced changes in the normally maintained configuration between the membrane bound

complexes (as described above) or from applied static electric fields (as evidenced by the streaming patterns described for the cells exposed to a control stimulus of a direct current (d.c.) field).

V. SUMMARY

The effects of radiofrequency radiation on internodal cells of Nitella have been shown to agree well with theoretical predictions of RF interactions with excitable cells. At frequencies below an upper limit (defined by membrane electrical parameters), RFR acts to directly excite the cells in a manner not unlike that which results from conventionally applied electrical stimuli. At higher frequencies, the membrane response appears to be of largely thermal nature.

No cessation of streaming was observed in cells irradiated with frequencies above 10 KHz. At the frequencies and field strengths used here, RF interactions with the streaming mechanism appear to be of thermal origin. No evidence was observed which would suggest that the cessation of streaming resulting from RFR-induced excitation might be due to a mechanism distinct from that which normally causes calcium ion release during an action potential.

A theoretical model has been proposed to describe the molecular basis of the action potential induced release of calcium ion. The model was based on microscopic observations of RF induced streaming alterations and theoretically defined electrical interactions at the cell surface. The close coupling of excitability and streaming cessation was explained in terms of an electrostatically defined relationship between an "action-potential complex" and a calcium dependent bicarbonate transport mechanism of the membrane.

AD-A116 713

AIR FORCE INST OF TECH WRIGHT-PATTERSON AFB OH F/G 6/18
INTERACTIONS OF RADIOFREQUENCY RADIATION WITH NITELLA: ELECTRIC--ETC(U)
MAR 82 L S WONG
AFIT/NR/82-11T

UNCLASSIFIED

NL

2nd 2



END
DATE
7 82
DTIC

Experimental evidence of RF interactions at the cell surface have been shown here. The effect of such perturbations on the internal functioning of the cell have been suggested to include alterations in streaming control and temporary changes in the arrangement of membrane bound macromolecules. The extent to which these proposed RF interactions might interfere with other cellular functions is a springboard for further investigation.

APPENDIX

ELECTROMAGNETIC RADIATION (EMR)

The electromagnetic spectrum is depicted in Figure 17. Names are associated with the various regions of the spectrum and identify the experimental means of detecting or producing them. All these waves are of the same nature (sinusoidally oscillating and mutually propagating electric and magnetic fields) and speed (the "speed of light", 3×10^8 m/s); they differ only in frequency and, therefore, energy.

The spectrum is divided into two general types of radiation, according to the energy of the waves: ionizing and nonionizing. The energy of a given frequency of radiation is defined as $E = hf$ [E-energy of a photon of radiation in electron-volts (eV); h-Planck's constant, 4.14×10^{-15} eV/s; f-frequency of the radiation in cycles/s or Hertz (Hz)]. Ionizing radiation, which includes x-rays, gamma rays, cosmic rays, α - and β -particles, has associated energies of a few thousand eV to hundreds of MeV (10^6 eV). Nonionizing radiation has corresponding energies of 10^{-2} to 10^2 eV and includes visible infrared, microwave, and radiowave frequencies. The present work is concerned only with EMR within the nonionizing portion of the spectrum.

The "intensity" of an electromagnetic field can be expressed in a number of different ways: field strength (volts/centimeter, v/cm) absorbed or incident power (watts/kilogram, w/kg), power density (volts/cubic centimeters, v/cm³). The following

FREQUENCY (Hz)

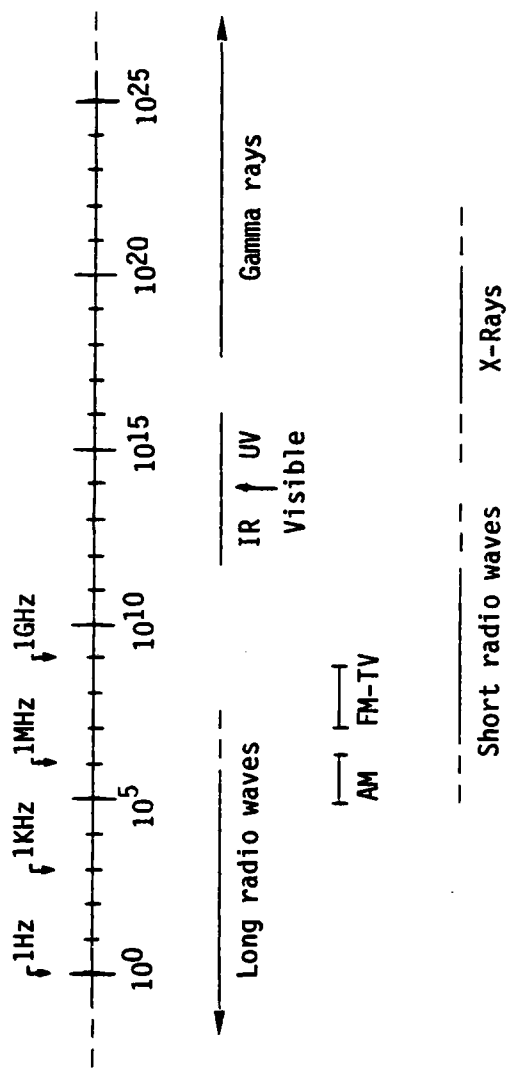

FIGURE 17
THE ELECTROMAGNETIC SPECTRUM
(from Halliday and Resnick, 1978)

definition of additional terms and abbreviations may be helpful to the reader:

EMR-electromagnetic radiation, the entire electromagnetic spectrum

RF or RFR-radiofrequency (radiation), EMR of frequencies up to 10^{10} Hz.

MW or MWR-microwave (radiation), EMR of frequencies between 10^9 - 10^{10} Hz.

Hz-Hertz, cycles per second, the frequency of the irradiation. Prefixes indicate orders of magnitude: kilohertz, 10^3 Hz (KHz); megahertz, 10^6 Hz (MHz); gigahertz, 10^9 Hz (GHz).

For a collection of investigations into the effects of nonionizing radiation on living systems, the reader is directed to Vol. 247, Annals of the New York Academy of Science, Biologic Effects of Nonionizing Radiation, 1975.

REFERENCES

- Albert, E.N. and M. De Santis. 1975. Do microwaves alter nervous system structure? *Ann. N.Y. Acad. Sci.* 247:87-108.
- Albert, E., C. Blackman, and F. Slaby. 1980. Calcium dependent secretory protein release and calcium efflux during RF irradiation of rat pancreatic tissue slices. Symposium URSI, Jouy-en-Josas, Juillet.
- Allen, N.S. 1974. Endoplasmic filaments generate the motive force for rotational streaming in Nitella. *J. Cell Biol.* 63:270-287.
- Allen, N.S., 1976. Undulating filaments in Nitella endoplasm and motive force generation. In: *Cell Motility*. Ed. Goldman, R., T. Pollard, and J. Rosenbaum. Cold Spring Harbor Laboratory.
- Allen, N.S. 1980. Cytoplasmic streaming and transport in the characean alga Nitella. *Canad. J. of Botany.* 58:786-796.
- Allen, N.S. and R.D. Allen. 1978. Cytoplasmic streaming in green plants. *Ann. Rev. Biophys. Bioeng.* 7:497-526.
- Allen, N.S., R.D. Allen, and T.E. Reinhart. 1976. Confirmed: the existence of abundant endoplasmic filaments in Nitella. *Biol. Bull.* 151:398 (abstract).
- Allis, J.W. and B.L. Sinha. 1981. Fluorescence depolarization studies of red cell membrane fluidity: the effect of exposure to 1.0-GHz microwave radiation. *Bioelectromagnetics.* 2:13-22.

- Barry, W.H. 1968. Coupling of excitation and cessation of cyclosis in Nitella: role of divalent cations. *J. Cell Physiol.* 72:153-160.
- Bawin, S.M., L.K. Kaczmarek, and W.R. Adey. 1975. Effects of modulated VHF fields on the central nervous system. *Ann. N.Y. Acad. Sci.* 247:74-81.
- Bennett, M.C. and Sir E. Rideal. 1954. Membrane behavior in Nitella. *Proc. Roy. Soc. London.* 142:483-496.
- Blackman, C.F., S.G. Benane, J.A. Eilder, D.E. House, J.A. Lampe and J.M. Faulk. 1980. Production of calcium ion efflux from brain tissue by radiofrequency radiation: effect of sample number and modulation frequency on the power-density window. *Bioelectromagnetics.* 1:35-43.
- Blackman, C.F., S.G. Benane, C.M. Weil, and J.S. Ali. 1975. Effects of nonionizing electromagnetic radiation on single-cell biologic systems. *Ann. N.Y. Acad. Sci.* 247:352-366.
- Blatt, F.J. and Y. Kuo. 1976. Absence of biomagnetic effects in Nitella. *Biophysical Journal.* 16:441-444.
- Blinks, L.R., E.S. Harris and W.J.V. Osterhout. 1928. Studies on stimulation in Nitella. *Proc. Soc. Ex. Biol. and Med.* 26:836-838.
- Bush, L.G., D.W. Hill, A. Riazzi, L.J. Stensaas, L.M. Partlow and O.P. Gandhi. 1981. Effects of millimeter-wave radiation on monolayer cell cultures. *Bioelectromagnetics.* 2:151-160.

- Cain , C.A. 1981. Biological effects of oscillating electric fields: role of voltage-sensitive ion channels. *Bioelectromagnetics*. 2:23-32.
- Chen, J.W. and N. Kamiya. 1975. Localization of myosin in the internodal cell of Nitella as suggested by differential treatment with N-Ethylmaleimide. *Cell Stru. and Funct.* 1:1-9.
- Cole , K. and H.J. Curtis. 1938. Electric impedance of Nitella during activity. *J. Gen. Physiol.* 22:37-64.
- Findlay, G.P. 1959. Studies of action potentials in the vacuole and cytoplasm of Nitella. *Aust. J. Biol. Sci.* 12:412-426.
- Frohlich, H. 1980. The biological effects of microwaves and related questions. *Advances in Elect. and Electron Physics*. 53:85-152.
- Greenebaum, E.M. Goodman and M.T. Marron. 1979. Extremely-low-frequency fields and the slime mold Physarum polycephalum: Evidence of depressed cellular function and internuclear interaction. *Radio. Sci.* 14:103-107.
- Halliday, D. and R. Resnick. 1978. *Physics*, third edition, parts 1 and 2. Wiley and Sons, Canada.
- Harvey, E.N. 1942. Hydrostatic pressure and temperature in relation to stimulation and cyclosis in Nitella flexilis. *J. of Gen. Physiol.* 25:855-863.
- Hayama, T., T. Shimmen, and M. Tazawa. 1979. Participation of Ca^{++} in cessation of cytoplasmic streaming induced by membrane excitation in Characeae internodal cells. *Protoplasma*. 99:305-321.

- Hayama, T. and M. Tazawa. 1980. Ca^{++} reversibly inhibits active rotation of chloroplasts in isolated cytoplasmic droplets of Chara. Protoplasma. 102:1-9.
- Hayashi, T. 1960. Experimental studies on protoplasmic streaming in characeae. Sci. Papers of Coll. of Gen. Ed., U. of Tokyo. 10:245-282.
- Hayashi, T. and E. Kasmitsubo. 1959. Plasmolysis in characeae. Bot. Mag, Tokyo. 72:853-854.
- Hill, S.E. 1941. The relation of streaming and action potentials in Nitella. Biol. Bull. Woods Hole. 81:296.
- Hogg, J., E.J. Williams, and R.J. Johnston. 1968. The temperature dependence of the membrane potential and resistance in Nitella translucens. Biochimica et Biophysica Acta. 150:640-648.
- Hope, A.B. and P.A. Aschberger. 1970. Effects of temperature on membrane permeability to ions. Aust. J. Biol. Sci. 23:1047-1060.
- Hope, A.B. and N.A. Walker. 1975. The physiology of giant algal cells. Cambridge U. Press, London.
- Jaffe, R.A., B.L. Laszewski, and D.B. Carr. 1981. Chronic exposure to a 60-Hz electric field. Effects on neuromuscular function in the rat. Bioelectromagnetics. 2:227-239.
- Kamitsubo, E. 1972a. A "window technique" for detailed observation of characean cytoplasmic streaming. Exptl. Cell Res. 74:613-616.

- _____. 1972b. Motile protoplasmic fibrils in cells of the characeae. *Protoplasma*. 74:53-70.
- _____. 1980. Cytoplasmic streaming in characean cells: role of subcortical fibrils. *Can. J. Bot.* 58:760-765.
- Kamiya, N. 1960. Protoplasmic streaming. *Ann. Rep. Scient. Works, Fac. Sci. Osaka U.* 8:13-41.
- _____. 1981. Physical and chemical basis of cytoplasmic streaming. *Ann. Rev. Plant Physiol.* 32:205-236.
- Kato, T. and Y. Tonomura. 1977. Identification of myosin in N. flexilis. *J. Biochem.* 82:777-782.
- Kersey, Y.M., P.K. Hepler, and A. Barry. 1976. Polarity of actin filaments in characean algae. *Proc. Nat. Acad. Sci.* 73:165-167.
- Kishimoto U. 1965. Voltage clamp and internal perfusion studies on Nitella internodes. *J. Cell and Comp. Physiol.* 66:43-54.
- _____. 1966. Action potential of Nitella internodes. *Plant and Cell Physiol.* 7:559-572.
- _____. 1968. Response of Chara internodes to mechanical stimulation. *Ann. Rep. of Biol. Works, Fac. Sci. Osaka Univ.* 16:61-66.
- Kishimoto, U. and H. Akabori. 1959. Protoplasmic streaming of an internodal cell of Nitella flexilis. *J. Gen. Physiol.* 42:1167-1183.
- Kuffler, S.W. and J. G. Nicholls. 1976. From neuron to brain: A cellular approach to the function of the nervous system. *Sinauer Assoc., INC., Mass.*

- Kuroda, K. 1964. Behavior of naked cytoplasmic drops isolated from plant cells. In: Primitive motile systems in biology. Ed. Allen, R.D. and N. Kamiya, pp 31-44. NY-London: Academic Press.
- Kuroda, K. and N. Kamiya. 1981. Behavior of cytoplasmic streaming in Nitella during centrifugation as revealed by the television centrifuge microscope. *Biorheology*. 18:633-641.
- Lin, J.C. and M.I. Lin. 1980. Studies of microwave and blood-brain barrier interaction. *Bioelectromagnetics*. 1:313-322.
- Liu, L.M., F. Garber, and S.F. Cleary. 1982. Investigation of the effects of continuous wave, pulse- and amplitude modulated microwaves on single excitable cells of Chara corallina. *Bioelectromagnetics* (In Print).
- Lucas, W.J. 1976. The influence of Ca^{++} and K^{+} on $\text{H}^{14}\text{CO}_3^{-}$ influx in internodal cells of Chara coralina. *J. Exp. Bot.* 27:32-42.
- McRee, D.I. and H. Wachtel. 1980. The effects of microwave radiation on the vitality of isolated frog sciatic nerves. *Rad. Res.* 82:536-546.
- Miller, M.W., E.L. Carstensen, D. Robertson, and S.Z. Child. 1980. 60 Hz electric field parameters associated with the perturbation of a eukaryotic cell system. *Radiat. Environ. Biophys.* 18:289-300.
- Nagai, R. 1979. Cytoplasmic streaming in plant cells. *What's New In Plant Physiology*. 10:45-48.

- Nagai, R. and N. Kamiya. 1977. Differential treatment of Chara cells with cytochalasin B with special reference to its effect on cytoplasmic streaming. *Exp. Cell Res.* 108:231-237.
- Nagai, R. and U. Kishimoto. 1964. Cell wall potential in Nitella. *Plant Cell Physiol.* 5:21-31.
- Nagai, R. and L.T. Rebhun. 1966. Cytoplasmic microfilaments in streaming Nitella cells. *J. Ultrastr. Res.* 14:571-589.
- Osterhout, W.J.V. 1927. Some aspects of bioelectrical phenomena. *J. Gen. Phys.* 11:83-99.
- Palevitz, B.A., J.F. Ash, and P.K. Hepler. 1974. Actin in the Green Alga, Nitella. *Proc. Nat. Acad. Sci.* 71:363-366.
- Palevitz, B.A. and P.K. Hepler. 1975. Identification of actin in situ at the ectoplasm-endoplasm interface of Nitella. *J. Cell Biol.* 65:29-38.
- Paulsson, L.E., Y. Hamnerius, and W.G. McLean. 1977. The effects of microwave radiation on neurotubules and axonal transport. *Rad. Res.* 70:212-223.
- Pickard, W.F. 1968. The correlation between electrical behavior and cytoplasmic streaming in Chara braunii. *Can. J. Bot.* 47:1233-1240.
- _____. 1971. Further observations on cytoplasmic streaming in Chara braunii. *Can. J. Bot.* 50:703-711.
- _____. 1974. Hydrodynamic aspects of protoplasmic streaming in Chara braunii. *Protoplasma.* 82:321-339.

- Pickard, W.F., Y.H. Barsoum, and F.J. Rosenbaum. 1980. Is the characean plasmalemma a radio-frequency rectifier? *Bioelectromagnetics*. 1:216 (abstract).
- Pickard, W.F. and Y.H. Barsoum. 1981. Radio frequency bioeffects at the membrane level: separation of thermal and athermal contributions in the characeae. *J. Membrane Biol.* 61:39-54.
- Pickard, W.F. and F.J. Rosenbaum. 1978. Effects of microwaves at the membrane level: two possible athermal electrophysiological mechanisms and a proposed test. *Math. Biosciences*. 39:235-253.
- Poo, M. and K.R. Robinson. 1977. Electrophoresis of concanavalin A receptors along embryonic muscle cell membrane. *Nature*. 265:602-605.
- Schwan, H.P. 1971. Interactions of microwave and radio frequency radiation with biological systems. *IEEE Trans. on MW Theory*. MTT 19:146-152.
- Schwan, H.P. and K.R. Foster. 1980. RF field interactions with biological systems: electrical properties and biophysical mechanisms. *Pro. IEEE* 68:104-113.
- Shelton, W.W. Jr. and J.H. Merritt. 1981. In vitro study of microwave effects on calcium efflux in rat brain tissue. *Bioelectromagnetics*. 2:161-167.
- Sheppard, A.R., S.M. Bawin, and W.R. Adey. 1979. Models of long range order in cerebral macromolecules: effects of sub-ELF and of modulated VHF and UHF fields. *Radio Sci.* 14:141-145.

- Singer, S.J. and G.L. Nicholson. 1972. The fluid mosaic model of the structure of cell membranes. *Science*. 175:729-730.
- Spiegel, R.J. and W.T. Joines. 1973. A semi-classical theory for nerve excitation by a low intensity electromagnetic field. *Bull. of Math Biol.* 35:591-604.
- Steneck, N.H., H.J. Cook, A.J. Vander and G.L. Kane. 1980. The origins of US safety standards for microwave radiation. *Science*. 208: 1230-1235.
- Straus, K. 1979. Microwave induced inhibition of protoplasmic streaming in Nitella. Undergraduate Honors Thesis. Dartmouth College, Hanover, N.H.
- Stuchly, M.A. 1979. Interaction of radiofrequency and microwave radiation with living systems. *Rad. and Environ. Biophys.* 16:1-14.
- Taylor, E.M. and B.T. Ashleman. 1975. Some effects of electromagnetic radiation on the brain and spinal cord of cats. *Ann. N.Y. Acad. Sci.* 247:63-73.
- Taylor, L.S. 1981. The mechanism of athermal microwave biological effects. *Bioelectromagnetics*. 2:259-267.
- Tazawa, M., M. Kikuyama, and T. Shimmen. 1976. Electric characteristics and cytoplasmic streaming of characean cells lacking tonoplast. *Cell Struct. and Funct.* 1:165-176.
- Tazawa, M. and U. Kishimoto. 1964. Studies on Nitella having artificial cell sap. II. Rate of cyclosis and electrical potential. *Plant and Cell Physiol.* 5:45-59.

- _____. 1968. Cessation of cytoplasmic streaming of Chara internodes during action potential. *Plant and Cell Physiol.* 9:361-368.
- Wachtel, H., R. Seaman, and W. Joines. 1975. Effects of low-intensity microwaves on isolated neurons. *Ann. N.Y. Acad. Sci.* 247:46-62.
- Webber, M.M., F.S. Barnes, L.A. Seltzer, T.R. Bouldin, and K.N. Kedar. 1980. Short microwave pulses cause ultrastructural membrane damage in neuroblastoma cells. *J. of Ultrastructure Res.* 71:321-330.
- Williamson, R.E. 1974. Actin in the alga Chara corallina. *Nature.* 241:801-802.
- _____. 1975. Cytoplasmic streaming in Chara: a cell model activated by cytochalasin B. *J. Cell Sci.* 17:655-668.
- Zimmerman, U. and F. Beckers. 1978. Generation of action potentials in Chara corallina by turgor pressure. *Planta.* 138:173-179.

DATE
ILMEI
-8