

AD-A116 739

AIR FORCE INST OF TECH WRIGHT-PATTERSON AFB OH
THE MELTING OF NATURAL SNOWFLAKES SUSPENDED IN A VERTICAL WIND --ETC(U)
JUN 62 © J DONOVAN

F/6 8/12

UNCLASSIFIED

AFIT/NR-62-12T

NL

lot 2

AD 739

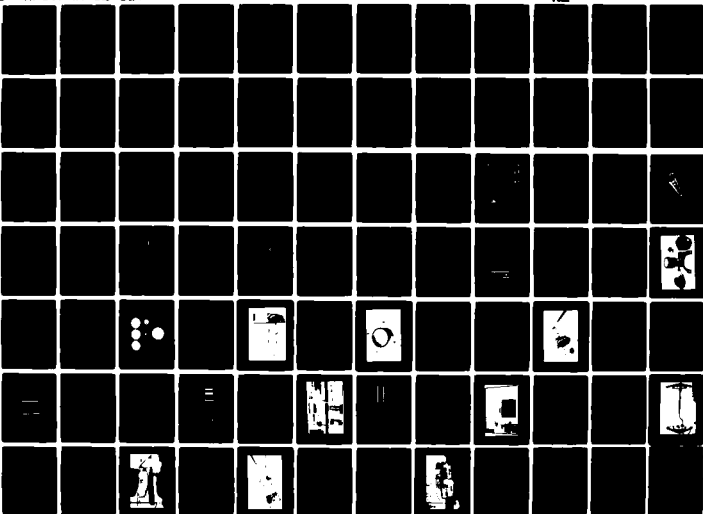

UNCLASS

SECURITY CLASSIFICATION OF THIS PAGE (When Data Entered)

1

REPORT DOCUMENTATION PAGE

READ INSTRUCTIONS BEFORE COMPLETING FORM

1. REPORT NUMBER AFIT/NR/82-12T	2. GOVT ACCESSION NO. AD-A116739	3. RECIPIENT'S CATALOG NUMBER
4. TITLE (and Subtitle) The Melting of Natural Snowflakes Suspended in a Vertical Wind Tunnel		5. TYPE OF REPORT & PERIOD COVERED THESIS/DISSERTATION
7. AUTHOR(s) Gregory James Donovan		6. PERFORMING ORG. REPORT NUMBER
9. PERFORMING ORGANIZATION NAME AND ADDRESS AFIT STUDENT AT: The University of Utah		8. CONTRACT OR GRANT NUMBER(s)
11. CONTROLLING OFFICE NAME AND ADDRESS AFIT/NR WPAFB OH 45433		10. PROGRAM ELEMENT, PROJECT, TASK AREA & WORK UNIT NUMBERS
14. MONITORING AGENCY NAME & ADDRESS (if different from Controlling Office)		12. REPORT DATE June 1982
		13. NUMBER OF PAGES 138
		15. SECURITY CLASS. (of this report) UNCLASS
		15a. DECLASSIFICATION/DOWNGRADING SCHEDULE

16. DISTRIBUTION STATEMENT (of this Report)
APPROVED FOR PUBLIC RELEASE; DISTRIBUTION UNLIMITED

17. DISTRIBUTION STATEMENT (of the abstract entered in Block 20, if different from Report)

18. SUPPLEMENTARY NOTES
APPROVED FOR PUBLIC RELEASE: IAW AFR 190-17
22 JUN 1982

Lynn E. Wolaver
LYNN E. WOLAVER
Dean for Research and Professional Development
AFIT, Wright-Patterson AFB OH

19. KEY WORDS (Continue on reverse side if necessary and identify by block number)

20. ABSTRACT (Continue on reverse side if necessary and identify by block number)

ATTACHED

82 07 07 060

DTIC ELECTE
JUL 09 1982

AD A116739 COPY

THE MELTING OF NATURAL SNOWFLAKES
SUSPENDED IN A VERTICAL
WIND TUNNEL

by

Gregory James Donovan

A thesis submitted to the faculty of
The University of Utah
in partial fulfillment of the requirements for the degree of

Master of Science

Department of Meteorology

The University of Utah

June 1982

Accession For	
NTIS GRA&I	<input checked="" type="checkbox"/>
DTIC TAB	<input type="checkbox"/>
Unannounced	<input type="checkbox"/>
Justification	
By _____	
Distribution/ _____	
Availability Codes	
Dist	Avail and/or Special
A	



© Gregory James Donovan 1982

All Rights Reserved

ABSTRACT

↙ In order to study the atmospheric snowflake melting process, it is desirable to suspend a natural snowflake freely in an airstream. Previously, researchers have suspended the snowflake either by using nets, wires, etc. or by catching and then inserting it into a suspension chamber. Applying a number of new concepts, an apparatus capable of suspending the natural snowflake in an upward stream of air has been developed. Using the apparatus, the snowflake melting process has been studied under nearly natural conditions.

The new apparatus employs a diverging design with a concave upward velocity profile. This velocity profile cradles the snowflake in the bottom, thus centering it in the observation section. An insertion tube with a spring-loaded opening allows the snowflake to fall into the apparatus and be caught by the upward airflow. While being suspended freely in this column of air, it melts under conditions of controlled relative humidity and temperature. This permits measurements of its velocity, size and shape changes. The behavior of the snowflake during the melting process is also recorded by cameras. A newly developed valve controls the airflow in the chamber while maintaining the air conditions. The entire apparatus is portable, enabling measurements to be made where the snow is falling.

The experimental data casts some doubt about the currently accepted mechanism of snowflake melting; each snowflake melts into a single waterdrop. The behavior of snowflakes/crystals during their

melting processes varies according to size. Crystals from 1-3 mm in diameter display "helicoptering", or rotation about their vertical axes. As melting progresses, this rotation develops into an ever widening spiral, the "death spiral". Crystals less than 1 mm in diameter are the most easily suspended, but in their final fractions of a second of existence, they jump violently, either upward or to the side. A downward movement is the exception, rather than the rule. Larger crystals and snowflakes slowly melt, with a corresponding increase in fall velocity, until breaking apart. Depending on the size of the broken pieces, these either fall to the bottom of the chamber or are swept out of the observation area by the airstream. It appears that, as the snow crystal melts, the water is drawn to certain collection points on the crystal skeleton by surface tension. This exposes portions of the ice skeleton to the airstream, which then melt faster than those covered by the water, and the crystal separates into several pieces. This observation is further supported by the melting time data which shows no significant increase with size. This phenomenon was dominant in the melting process of all snowflakes observed in this study.

TABLE OF CONTENTS

ABSTRACT	iv
LIST OF FIGURES	viii
ACKNOWLEDGEMENTS	xi
CHAPTER	
1. INTRODUCTION	1
2. EXPERIMENTAL APPARATUS DESIGN CONSIDERATIONS	5
3. PAST STUDIES	10
Measurement of Fall Velocity	10
Suspension Chambers	19
4. FINAL DESIGN AND CONSTRUCTION OF APPARATUS	39
Suspension Section	39
Suspension Chamber	39
Settling Chamber	42
Honeycomb	42
Screens	44
Entrance Tunnel	47
Insertion Tube	49
Exit	51
Suction System	53
Vacuum and Power Source	53
Valve	53
Conditioning System	56
Heater	56
Humidifier	57
Photographic Apparatus	62
Prototype	62
Final Design	64
Measuring Equipment	68
Recorder	68
Air Velocity Meter	68
Hygrometer	71
Air Temperature	73
Artificial Snowflakes	73
Shelter	80

5. EXPERIMENTAL PROCEDURES	83
Deploying	83
Operations	84
Setting Up	84
Data Collection	86
Shutting Down	90
Data Analysis	90
6. RESULTS AND DISCUSSION	94
Apparatus' Performance	94
Qualitative Observations	97
Quantitative Observations	101
Velocity Change	103
Shape Change	107
Melting Rates	107
7. CONCLUSIONS AND RECOMMENDATIONS	116
Apparatus' Features	116
Main Findings	118
Recommendations for Future Research	119
APPENDICES	
A. POWER REQUIREMENT OF HEATER	121
B. ANEMOMETER/RECORDER ACCURACY	123
C. EQUIPMENT CHECKLIST	125
D. OPERATIONS CHECKLISTS	128
E. ELECTRICAL SYSTEMS	130
F. FALL VELOCITY DETERMINATION	132
REFERENCES	134
VITA	138

LIST OF FIGURES

Figure		Page
2.1.	Initial Design of Snow Melting Apparatus	8
3.1.	Fall Velocity Measurement Apparatus	12
3.2.	Position of Camera System within the Coldroom	14
3.3.	Schematic Illustration of the Photographic System	15
3.4.	Fall Velocity Measurement Apparatus	16
3.5.	Fall Velocity Measurement Apparatus	18
3.6.	Spin Tunnel Velocity Profile	21
3.7.	Hydrometeor Suspension Apparatus	23
3.8.	Hydrometeor Suspension Apparatus	24
3.9.	Swiss Hail Tunnel	26
3.10.	Hydrometeor Suspension Apparatus	27
3.11.	Hydrometeor Suspension Apparatus	29
3.12.	UCLA Hydrometeor Suspension Apparatus	31
3.13.	Hydrometeor Suspension Apparatus	32
3.14.	Ice Crystal Suspension Apparatus	34
3.15.	Ice Crystal Suspension Apparatus	36
4.1.	Major Sections of Apparatus	40
4.2.	Photograph of Honeycombs and Cutting Device	43
4.3.	Velocity Profiles	46
4.4.	Photograph of Screens	48
4.5.	Photograph of Insertion Tube	50
4.6.	Photograph of Suspension Chamber Exit	52

4.7.	Photograph of Valve with Anemometer Probe	55
4.8.	Photograph of Heater and Cover	58
4.9.	Photograph of Air Distribution Device	59
4.10.	Conditioning System	60
4.11.	Photographic Section	63
4.12.	Photograph of Photographic Apparatus	65
4.13.	Photographic Apparatus	66
4.14.	Photograph of Instrument Box	69
4.15.	Anemometer Calibration Curve	70
4.16.	Photograph of Hygrometer	72
4.17.	Hygrometer Thermometers' Calibration Curves	74
4.18.	Calibration Line for Settling Chamber Thermocouple	75
4.19.	Calibration Line for Outside Air Temperature Thermocouple	76
4.20.	Photograph of Settling Chamber Thermocouple	77
4.21.	Photograph of Artificial Snowflakes	79
4.22.	Apparatus' Positioning in Shelter	81
4.23.	Photograph of Apparatus' Shelter	82
5.1.	Snowflake Extractor Device	85
5.2.	Sample Recorder Strip	87
5.3.	Suspended Snowflake and Chamber Reference Lines	91
5.4.	Snowflake Size Approximation	91
5.5.	Prototype Photographic System's Image	93
5.6.	Enlargement of Snowflake Image from Prototype Photographic System	93
6.1.	Snowflake Melting Sequence	99
6.2.	Fall Velocity vs Time	104

6.3.	Fall Velocity vs Time (at 4°C, 90% RH)	105
6.4.	Fall Velocity vs Time (at 4°C, 100% RH)	105
6.5.	Fall Velocity vs Time (at 2°C, 100% RH)	106
6.6.	Fall Velocity vs Time (at 3°C, 100% RH)	106
6.7.	Horizontal Cross-Sectional Area vs Time	108
6.8.	Horizontal Cross-Sectional Area vs Time (at 4°C, 90% RH)	109
6.9.	Horizontal Cross-Sectional Area vs Time (at 2°C, 100% RH)	110
6.10.	Horizontal Cross-sectional Area vs Time (at 3°C, 100% RH)	111
6.11.	Horizontal Cross-Sectional Area vs Time (at 4°C, 100% RH)	112
6.12.	Melting Time vs Initial Diameter	113
6.13.	Melting Time vs Initial Horizontal Cross-Sectional Area (90% RH)	115
6.14.	Melting Time vs Initial Horizontal Cross-Sectional Area (100% RH)	115

ACKNOWLEDGEMENTS

I wish to express my appreciation foremost to my Heavenly Father for the talents and opportunities He has given me throughout my life and most especially for the help I've received during this research.

Secondly, I acknowledge my love and gratitude to my wife, Diane, and our children for their patience, understanding and encouragement throughout our lives together, but especially during the trials and frustrations of the last 18 months. Also, I'm eternally grateful for the influence for good my parents have been, for their "You can do it" confidence in me and their love and support throughout my life.

I'm very thankful to my fellow students and the special friends I've made during my graduate work for all the help they've given me and things they've taught me.

I'm also grateful for the friendship developed with my working companion, Rick Savage, through the trials and successes of this project.

And finally, I wish to express my appreciation to Dr. Norihiko Fukuta, without whose assistance this study could not have been completed, and to Drs. Elford Astling and Kenneth Sasson for serving on my committee.

This research was supported by the United States Air Force, under contract number F-19628-61-C-0003.

Chapter 1

INTRODUCTION

Snow--boon to skiers, benefaction to farmers, and bane to sun worshippers--is an integral part of the precipitation process, precipitation which throughout history has had such a controlling influence on civilizations. Man is dependent primarily on water for his very life. The absence or amount of water available dictates where he lives, what he grows and eats, what he wears, indeed his very culture, to a large extent. The availability of water has caused some civilizations to flourish while destroying others. It has inflicted great personal and economic hardships upon mankind through floods, crop damage, droughts, etc. It is the precipitation process which transports water from the atmosphere to the surface of the earth. Mason (1971) points out that, with the exception of some tropical showers, the ice phase is always involved in the precipitation process, even when the final form observed on the ground is rain. These raindrops form when ice crystals, having grown too large to remain suspended, fall and melt at lower altitudes. This process, first suggested by A. Wegener in 1911 and developed by T. Bergeron in 1933 (Mason, 1975), is known as the Bergeron mechanism. It is this process of snowflakes/ice crystals falling and melting that is the focus of this study.

While this study was certainly not the first on the melting process of snowflakes, it undertook some objectives which had never

before been accomplished. Simply put, we sought to gain information on the size and shape of snowflakes, their mass and fall velocity during the melting process. What makes this study unique is that this information was obtained while the natural snowflake was suspended in a column of air, completely independent of any artificial support (wires, nets, etc.). To accomplish this required the design, construction and operation of a vertical wind tunnel, small enough to be transported to the field. This apparatus required extensive research and trial and error to perfect, but it enabled the gathering of data concerning the melting process of natural snowflakes that is of interest to both the scientific and the non-scientific communities alike.

The Department of Defense has some specific interests in the research carried out in this study, a part of an Air Force melting layer project. The erosion of hypersonic vehicles from ice/water particles in the atmosphere, similar to erosion of rock due to wind-borne sand particles, has recently become very important. From damage to missile nose cones, thus affecting the guidance systems, to potential damage to vehicles returning from space, the presence of ice/water particles has an impact on users and designers alike. Even the artillery officer must consider how his projectile will be affected on its flight to its target. With the advance of technology, the degradation of electromagnetic energy in the atmosphere is being studied. Two items of interest are the effects ice crystals/water drops have on laser weapons and microwave transmissions. Areas of high water drop content (i.e., the melting layer) have been found

to have a significant impact on these systems; and forecasters have long wrestled with the problem of whether the forecasted partly cloudy skies will become showers. Rain versus snow on the ground may have a significant impact on a ground commander's strategy. A thorough knowledge of the melting process can aid the forecaster in determining whether the precipitation from a cloud will reach the ground, and in what form, or evaporate before arrival. These are only some of the military applications of knowledge gained through this study.

Much of the information obtained from this research is applicable to civilian and military concerns alike. The forecasting applications previously mentioned may enable the television weatherman to advise you as to whether you'll need a raincoat or only a sweater. Commercial and military aviation are interested in the icing of control surfaces on aerospace vehicles. Icing, or its threat, causes a substantial economic loss to the airlines every year in cancelled or rerouted flights, along with frustration and inconvenience to their customers. Icing can even cause the unwary pilot to have an accident. Because high liquid water content, thus most severe icing, is associated with the melting layer, the melting of snowflakes is of interest. Another problem that has recently gained publicity is that of wind shear, associated with turbulence and downdrafts. When precipitation evaporates, it cools the air which, now being heavier, sinks, creating a downdraft and turbulence. This shear has been identified as the cause of several commercial airline accidents in recent years. As in the other cases mentioned, a knowledge of the melting process of ice crystals/snowflakes plays an integral part in understanding this.

phenomenon.

The desired capabilities of our apparatus are discussed in Chapter 2. Chapter 3 reviews the past efforts of others which most influenced our study. How these efforts were considered in the design and construction of our apparatus are explained in Chapter 4. Chapter 5 details the procedures used to collect the data. In Chapter 6, the performance of our equipment and the results of our data collection are discussed and conclusions and recommendations make up Chapter 7.

Chapter 2

EXPERIMENTAL APPARATUS DESIGN CONSIDERATIONS

This study required the design and construction of an apparatus which would enable the suspension of a natural snowflake in a column of air, free from artificial supports, under various conditions of temperature and relative humidity. From the observations and measurements conducted, a determination of the changes in the size, shape, mass and fall velocity of snowflakes during the melting process would be made. This chapter discusses the factors considered in the design of our apparatus.

The most important part of this study was the suspension apparatus which, at a very minimum, had to suspend the snowflake free of artificial supports. As will be discussed in Chapter 3, many studies have already been conducted on the melting process of snowflakes, using nets, mesh, etc. to suspend them. This study was to be conducted free of these artificial supports. This would allow data to be obtained on the natural melting of the snowflake, without any influence from other objects.

After the basic problem (suspension of the snowflake in an air column) was solved, the additional constraints of relative humidity and temperature control could be considered. We wanted the ability to control these factors. This meant the air entering the suspension chamber had to be conditioned first. The rate of melting of the

snowflake would be studied under various controlled air temperatures. From this data, the melting behavior could be assessed for any desired temperature. Control of the air's relative humidity in which the snowflake melted would reveal the effect of vapor transportation on the melting process. Data would be gathered which could lead to a more complete understanding of the effect the relative humidity has on the melting process.

The measurement of the fall velocity variation with time was required to tie all the melting data together. This knowledge would lead directly to an estimation of the depth of the melting layer.

The last desired parameter to be measured, mass, would give important new insight into the density of snowflakes. The mass would affect the melting rate of the snowflake.

Once the essentials (i.e., suspension of the snowflake, temperature and relative humidity control and measurement of fall velocity and mass) were considered, other factors could be allowed for. Some of these were photography, portability, durability and ease of operation. A good quality photograph of the snowflake at different times during the melting process would yield invaluable data. Mass determination, classification by type and size and shape relationships could be analyzed later, in the comfort of the laboratory. To study the melting of the natural snowflake, ideally, our equipment should be portable. This would enable us to travel to where the snow was falling. Portability leads to another design consideration, that of durability. Delicate scientific instruments would not withstand movements over snow covered roads without special protection. Finally, simplicity

of operation must be considered. Because the study is concerned with natural snowflakes, data collection would take place outdoors, during storms. Under these conditions, the operator(s) would not be functioning at peak efficiency. The apparatus should be designed to require minimum attention from the operator(s). The controls should be simple, as few as possible and not require precise, delicate movements.

Figure 2.1 shows the initial design of an apparatus satisfying the majority of the above mentioned criteria. As the snowflake fell into the apparatus, it would pass a camera/stroboscope arrangement which would enable a determination of its fall velocity. Because a snowflake's size would allow identification from the aerial photograph, and the probability of damage if caught, they would continue falling into the suspension chamber. Ice crystals, though, would be caught on a piece of velvet, placed under the camera, photographed and then dropped into the suspension chamber. This would give a record of their fall velocity prior to melting and allow easy identification. At the top of the suspension chamber, the exiting of the air would act to align the falling particle with the center of the suspension chamber. Once in the chamber, the particle would seek its own point of suspension. The design of the tunnel is divergent upward, meaning that the airspeed increases towards the bottom. Thus, when the air flow is adjusted properly, the particle would fall into the tunnel and balance at some point. As it melted, it would settle lower in the tunnel, but still remain suspended. The adjustments required by the operator, if any, would be small. Stability within the chamber is provided by the velocity profile (further discussed in later

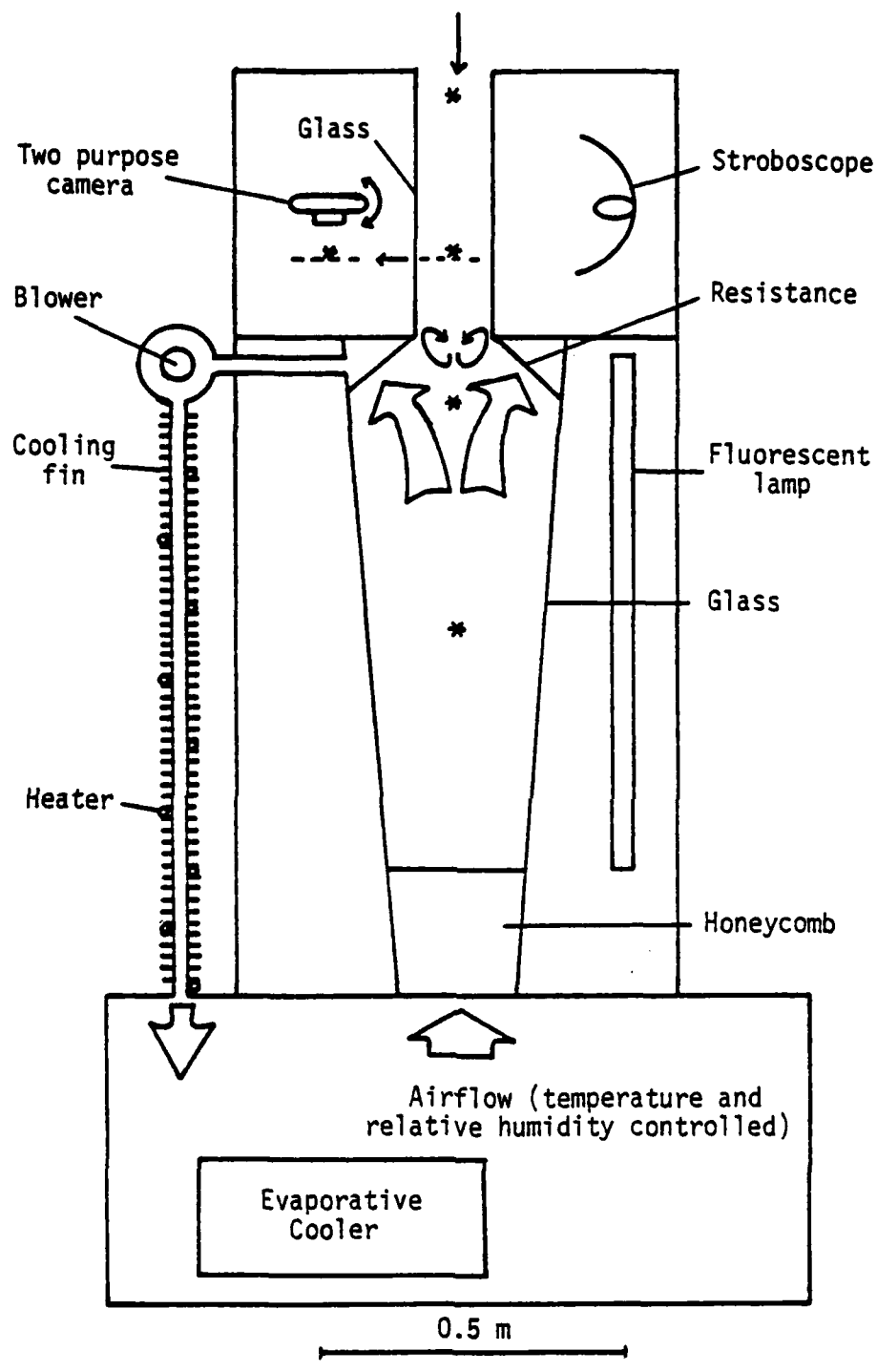

Fig. 2.1. Initial Design of Snow Melting Apparatus

chapters). The design of the apparatus in Fig. 2.1 is closed circuit, which provides precise control of the temperature and relative humidity. Cooling fins cool the air while heat is provided by heating tape. The relative humidity is controlled through an evaporative cooler.

The apparatus in Fig. 2.1 initially was thought to best satisfy our criteria. However, under close scrutiny, several problems surfaced. The apparatus was approximately two meters high, with initial photographing of the particle occurring at the top. This meant the operator would have to be standing on a stool or ladder. Dressed in heavy winter clothing, this was not desirable. If not sheltered, the stool or ladder would also be covered with snow, making it slippery. With the device being that big, it would have to be dismantled and reassembled at the observation site. Under cold, snowy conditions, possibly at night, this could present problems. Furthermore, the shelter would have to be quite large to protect the apparatus and operators. Erection of the shelter at the observation site would also be required. How all these potential problems were overcome and further design considerations incorporated into the construction of our apparatus are discussed in Chapter 4.

Chapter 3

PAST STUDIES

Precipitation processes have at the same time fascinated and baffled man since the beginning of time. Many studies have already been done on these processes. In this chapter the relevant results of our literature survey are reviewed in the areas of fall velocity measurement and suspension chambers.

Measurement of Fall Velocity

The fall velocity of an object is normally measured by recording the time interval it takes to fall through a known vertical distance. Early measurements were made using measuring sticks in one hand and a timing device in the other. With the development of technology, the accuracy of and the complexity of devices for measuring fall velocity have increased.

Magono (1950), Magono and Nakamura (1965), and Jiusto (1971) measured the time required for a snowflake to fall through an opening in their observation huts and reach the floor, three to four meters, using a precision stopwatch. These distances, they felt, were sufficient to give them an accurate measurement of the fall velocity of a snowflake.

Itoo, Yano, and Hama (1953) built a dark box in which the falling snowflake was illuminated by a stroboscopic high pressure mercury lamp. This process was recorded by a camera. The trace recorded

on the film was measured to determine the fall velocity for an individual snowflake.

Kinzer and Gunn (1951) measured the evaporation of waterdrops falling at their terminal velocity relative to the surrounding air. In doing this, they used two different instruments to determine fall velocity, one of which (shown in Fig. 3.1) approached our criteria of being portable, rugged, and simple to operate. As the raindrop fell past the camera, it was illuminated by an adjustable-frequency, multiple-flash light source which was angled 30 degrees to the optic axis of the camera, thereby providing dark field illumination of the drop. The camera was equipped with a well corrected lens and recorded the falling raindrop's position at successive equal intervals of time as a series of tiny spots on a negative. Even the largest of the drops appeared as tiny pinpoints of light, but this allowed calculation of their fall velocities.

In studying the terminal velocity of snowflakes, Langleben (1954) used a 16 mm cine-camera. He photographed the moving snowflakes against a dark background from a distance of three meters. Each snowflake produced a short streak, due to its movement while the camera's lens shutter was open, on every frame of the film. When the film was developed and played back, these streaks were followed from frame to frame. Knowing the vertical distance through which the flakes were falling and the camera speed, Langleben was able to make a velocity measurement for any particular snowflake.

Zikmunda and Vali (1972) studied falling snow crystals by using a stereoscopic camera system, with stroboscopic illumination, located

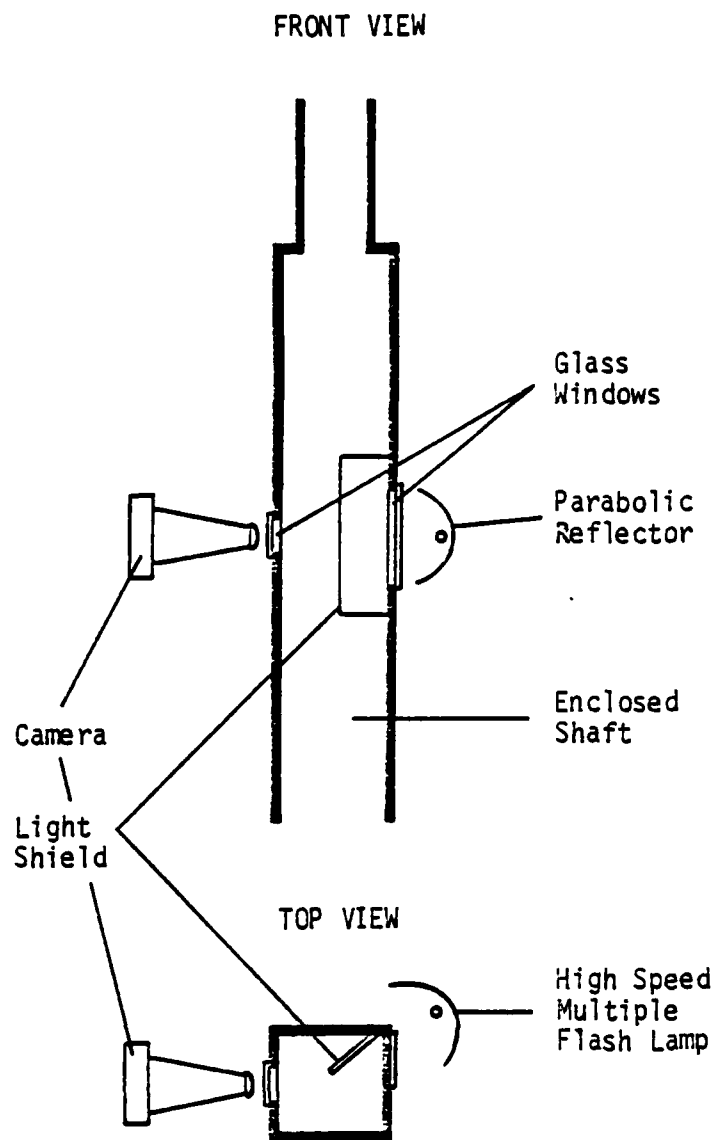

Fig. 3.1. Fall Velocity Measurement Apparatus
(after Kinzer & Gunn, 1951)

inside a large cold room, as shown in Fig. 3.2. Observations showed that crystals entering the cold room through the roof opening lost their horizontal component of motion quickly so that mean vertical motion was obtained approximately one meter below the opening. The camera system was enclosed by a black curtain to minimize air currents and entrance to this area was controlled through a second opening at the top. This opening was adjusted according to snowfall intensity to regulate the number of crystals reaching the camera viewing area. This apparatus used two Nikon F-250 motor-driven cameras with 50 mm focal length lenses and two high power stroboscopic flash units arranged on a common mounting assembly, as shown in Fig. 3.3. Although adjustable, a viewing distance of 30 cm was used most often. The usable depth of focus was about 4 cm. Illumination was provided by two flash units, set at 100 flashes per second. The camera shutters were operated manually to provide exposure times of 1-5 seconds. Determination of vertical motion was made from 8×10 in (20.3×25.4 cm) enlargements of the photographs. The position of the snow crystal was measured with respect to a vertical rod. Three to ten such velocity values for a given crystal were averaged to give the fall velocity.

Kajikawa's (1972) apparatus, as shown in Fig. 3.4, used the same principle as Zikmunda and Vali (1972), i.e., stroboscopic illumination of the falling snow crystal. A cylinder was used to direct the falling snow to the measuring chamber. A shutter controlled the amount of snow passing into the chamber. Illumination, for as short a period as possible, was provided by a stroboscopic light filtered through

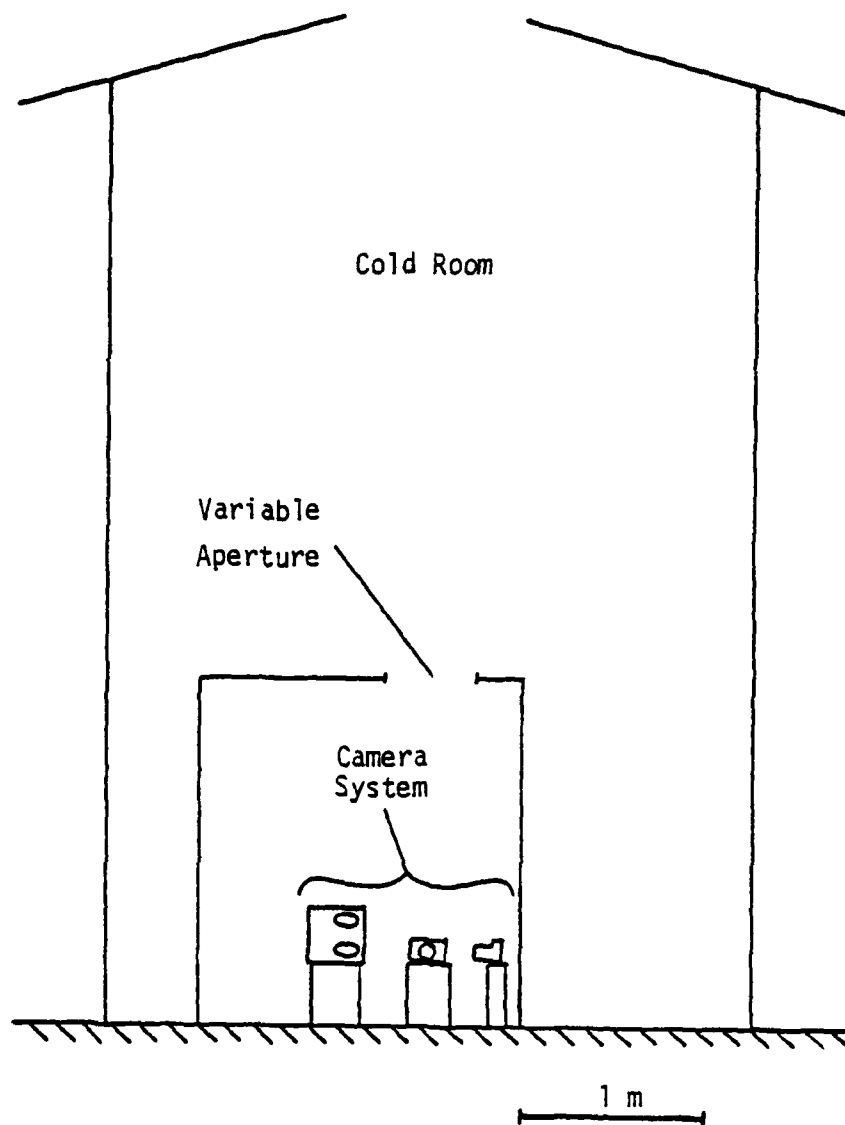

Fig. 3.2. Position of Camera System within the Coldroom
(after Zikmunda & Vali, 1972)

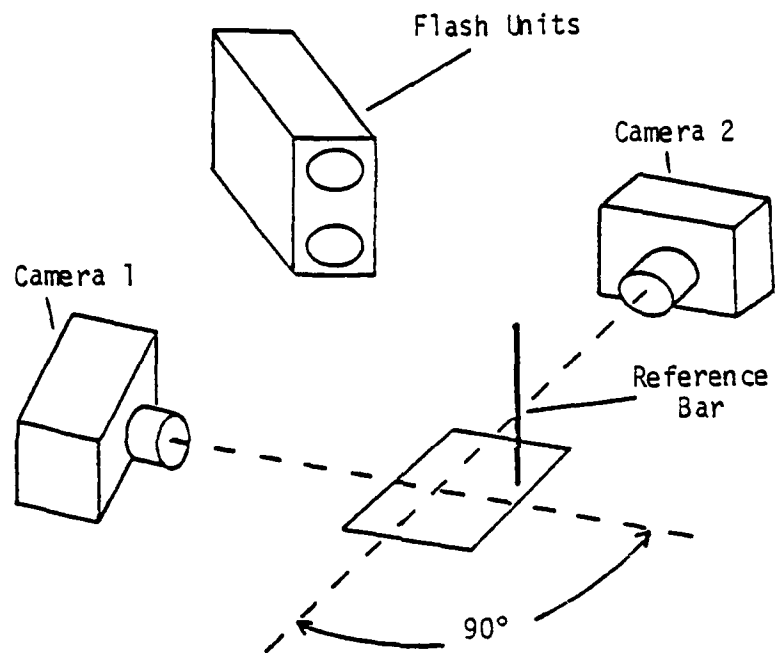

Fig. 3.3. Schematic Illustration of the Photographic System
(after Zikmunda & Vali, 1972)

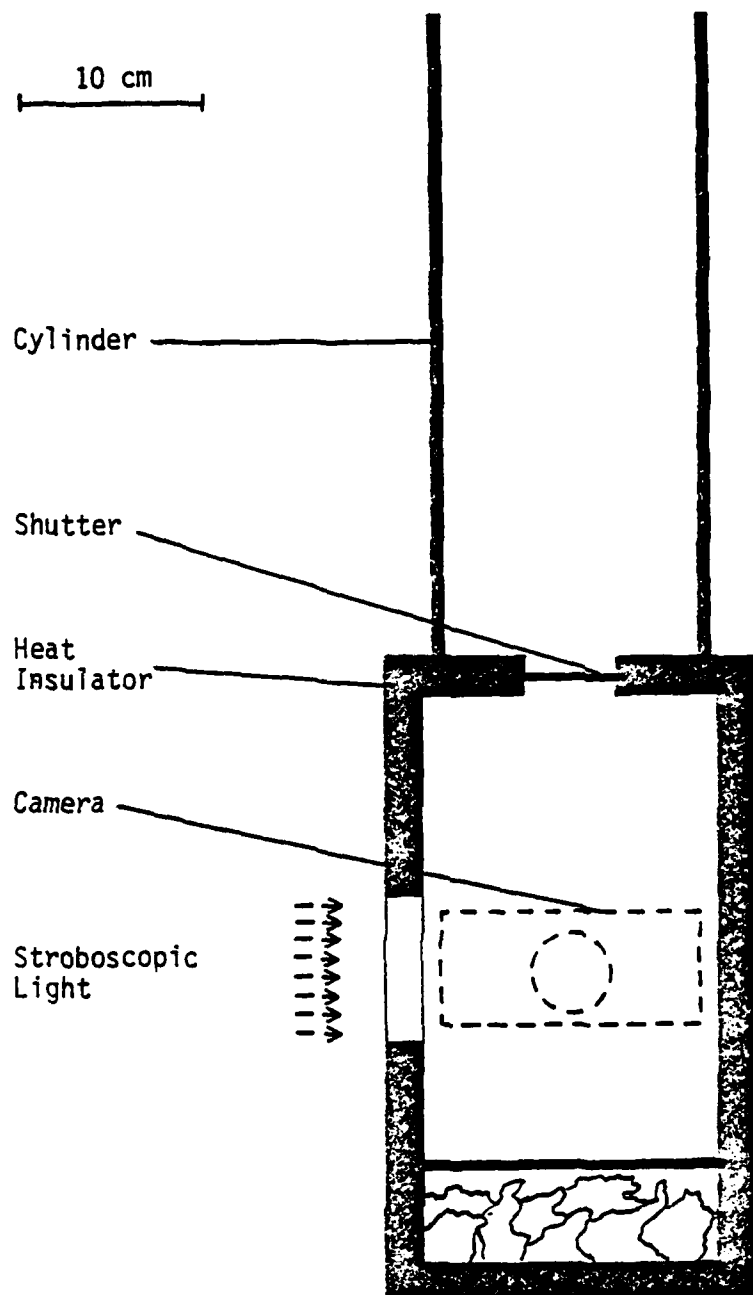

Fig. 3.4. Fall Velocity Measurement Apparatus
(after Kajikawa, 1972)

heat absorption glass. The camera was placed perpendicular to the illumination beam. The falling snow crystals were recorded as a line of dot marks on the photograph. Because the distances between the dots were almost the same, Kajikawa considered the snow crystals to be falling at their terminal velocities.

Locatelli and Hobbs (1974) used a new approach in measuring the fall speeds of solid precipitation particles. Shown in Fig. 3.5, the light sources consist of two incandescent lamps, transmitted by fiber optics as two parallel beams of light, one directly above the other. These are received by a similar set of fiber optics and the intensity of the two signals is recorded with two photomultiplier tubes. The decrease in intensity caused by a particle falling through the light beams is detected by the photomultiplier tubes and displayed on a storage oscilloscope. The time difference between intensity changes in the upper and lower beams is recorded and used to compute the fall velocity. Inlet holes of various sizes were used to control the number of particles passing through the light beams. The problems of two particles passing through the beams simultaneously and the particle missing the collection area after being measured necessitated many hours of observations to obtain a few reliable measurements.

Sasyo and Matsuo (1980) used this same principle to calculate the fall velocity of snowflakes. They used a vertical tunnel, 50 cm square and 120 cm deep, which was darkened inside. Two photocouplers, consisting of light emitting diodes and photodetectors, were placed at different heights in the tunnel. As a snowflake fell through the light beam, the photocoupler generated a signal which was recorded by

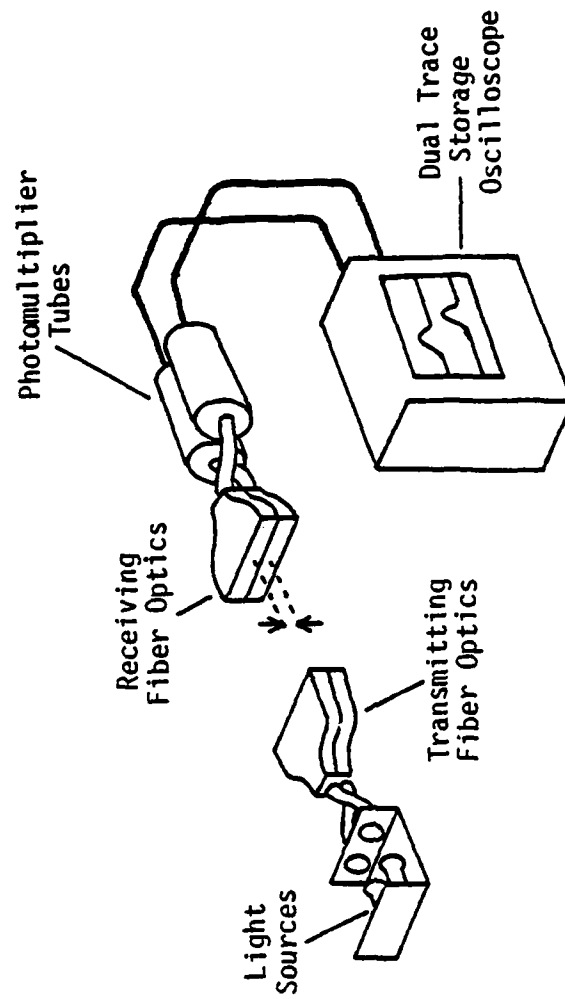

Fig. 3.5. Fall Velocity Measurement Apparatus
(after Locatelli & Hobbs, 1974)

a digital voltmeter equipped with a time interval measurement. With the two signals received from one snowflake falling and the distance between the photocouplers, the fall velocity was calculated. A photograph of the snowflake was obtained from a motor-driven camera located at the bottom of the tunnel and a stroboflash linked electrically with a photo-coupler. As with Locatelli and Hobbs' (1974) apparatus, the simultaneous fall of two or more snowflakes into the tunnel created measurement problems.

Suspension Chambers

To study hydrometeors, one would ideally follow the object from its formation in the cloud, through the atmosphere as it falls, to its arrival at the earth's surface, observing the changes it undergoes throughout its path. Of course this is impossible and, even if somehow accomplished, would present too many variables for an accurate analysis of the processes involved. A more feasible method is to study the object in a laboratory, under controlled conditions. Many different types of apparatuses have been constructed over the years to simulate as closely as possible the conditions found in nature.

Probably the first suspension chambers didn't truly suspend the particle in the airstream, but rather held it using some type of support. Because this method greatly simplifies the design of a chamber (turbulence and a delicate velocity profile are not critical factors), it is still used today. Drake and Mason (1966) used a mesh of ten micron diameter fibers to suspend small ice spheres in studying their melting process. Some scientists (Pruppacher and Neiburger, 1968) have felt that the aerodynamic characteristics of a melting snow crystal/

flake may make it impractical to freely suspend them. Matsuo and Sasyo (1981) studied the melting rate of snowflakes by first catching them, then depositing them on a nylon net (thread diameter 100 microns) in a vertical wind tunnel. While nets or other supports do have an effect on the airflow around a hydrometeor and the processes it undergoes, they allow for studies to be conducted in a laboratory. Under controlled conditions of air temperature, relative humidity, velocity, etc., an idea of the conditions actually occurring in nature can be formulated.

An invention by engineers in the early 1930's that has aided meteorologists is that of the spin tunnel. This is a wind tunnel with vertical airflow. They are most widely used to test spin (thus their name) characteristics of model aircraft. The downward movement of the model is compensated by adjustment of the upward air current velocity so that the model remains vertically stable with respect to an observer outside the tunnel. Spin tunnels are characterized by (1) a saucer-shaped velocity gradient in the test section which is about 5-10% lower at centerline than at the edge (Fig. 3.6), thus keeping the model spinning in the center of the tunnel; and (2) a fast response drive system to rapidly adjust the tunnel's air velocity. Many researchers have used various modifications of the spin tunnel in their studies.

If a rigid sphere is placed in a vertical stream of air confined in a uniformly tapered tube, it can be stably suspended at some particular height. This height is a measure of the airspeed, when the sphere's diameter is constant. If the airflow remains constant, the

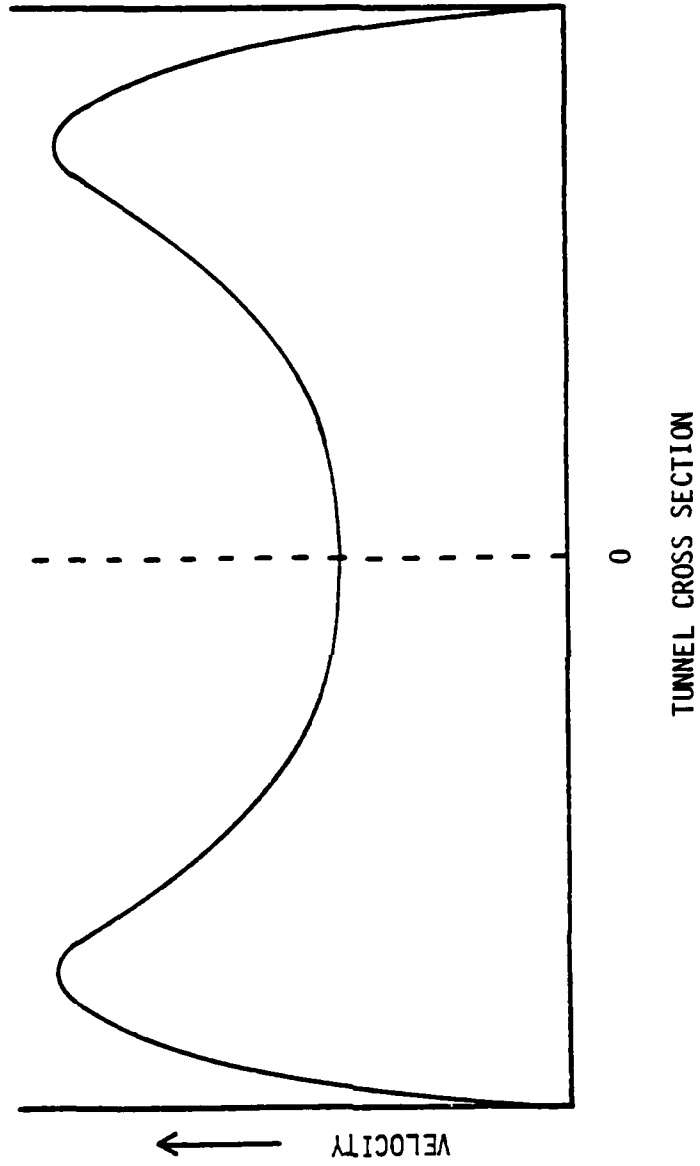

Fig. 3.6. Spin Tunnel Velocity Profile

suspension height will vary with the sphere's diameter. Kinzer and Gunn (1951) used this method in their study of freely falling water drops. Two different sized tapered glass tubes (shown in Fig. 3.7) were used in conjunction with a constant airflow. In the smaller tube, the droplet height was used to determine its size. For large drops, the larger tube was used. Here drops were supported on a rising column of air. The cone above the tube created a "dead spot" in which a drop was suspended.

In 1955, Telford, Thorndike and Bowen built a closed circuit chamber, shown in Fig. 3.8, consisting of an observation section, a return duct and a settling chamber. The air is driven by a fan in the return duct, down through a straightener, around two bends and through expansion vanes into a settling chamber. Here partitions of wire gauze and aluminum straighteners break up large scale turbulence. The air is then gathered by a large cone and directed into the observation section, where it finally escapes through a 5 cm high gauze cylinder. The return duct then brings the air back to the fan. The short cone catches drops which tend to fall back down the boundary layer existing near the tunnel walls. A 250 watt aircraft landing light aided visual observations. The heat from this light was removed by a water filter. This chamber was found to run turbulence free for approximately 15 minutes.

Kinzer and Cobb (1955) studied the growth and collection efficiency of raindrops using an apparatus similar to the small tapered tube previously used by Kinzer and Gunn (1951). The primary differences were that suction was used to draw cloud droplets through the

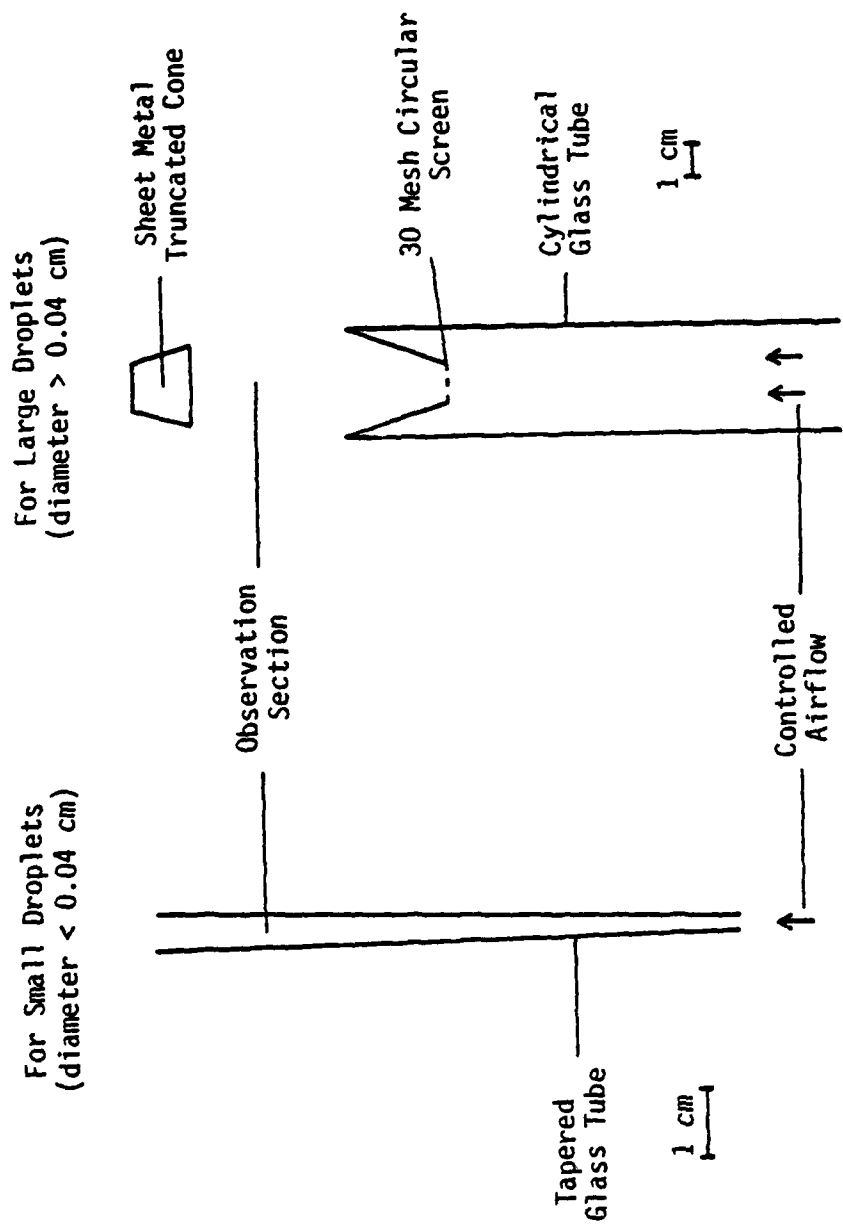

Fig. 3.7. Hydrometer Suspension Apparatus (after Kinzer & Gunn, 1951)

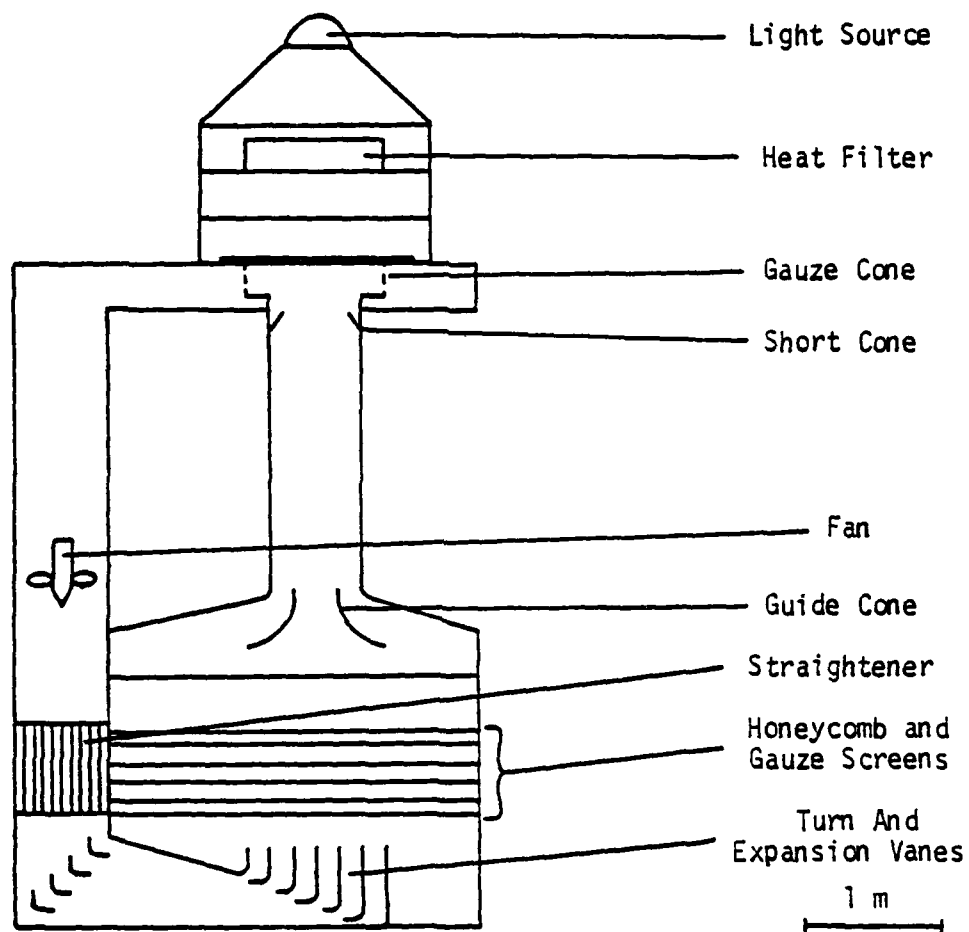

Fig. 3.8. Hydrometeor Suspension Apparatus
(after Telford, Thorndike & Bowen, 1955)

observation section and the air's condition (flowrate, temperature, absolute pressure and water content) was more controlled.

In 1958, Kinzer and Cobb built another chamber which incorporated a vertical glass cylinder. This cylinder was able to be tilted about four degrees in any direction. A droplet was found to drift unless the tube were tilted so that the airflow acting with gravity caused it to move safely back to its original location. Practice enabled them to observe a single droplet continuously for an hour or more.

Hailstone research by the Swiss Federal Snow and Avalanche Research Institute led to the design and construction of the Swiss hail tunnel (List, 1959). It basically consists of a wind tunnel with a vertical observation section, is closed circuit and has an adjustable climate. Figure 3.9 diagrams the major components. The blower generates the necessary airspeed relative to the object suspended in the observation section. The air then passes through the air cooler and on to the heater. This has a capacity of 0 to 19 kw, making possible rapid changes of temperature. The air is cooled and then brought to the exact desired temperature with the heater. After this it passes to the filter where it is purified. Humidity is added to the air after making the 90 degree turn from the filter (equipment is not shown in Fig. 3.9). Various measuring probes are installed in the observation section and the test object can be illuminated and viewed through plexiglass windows. The remaining parts of the tunnel allow the air to expand slowly and return to the blower.

Cotton and Gokhale's (1967) apparatus, shown in Fig. 3.10, made

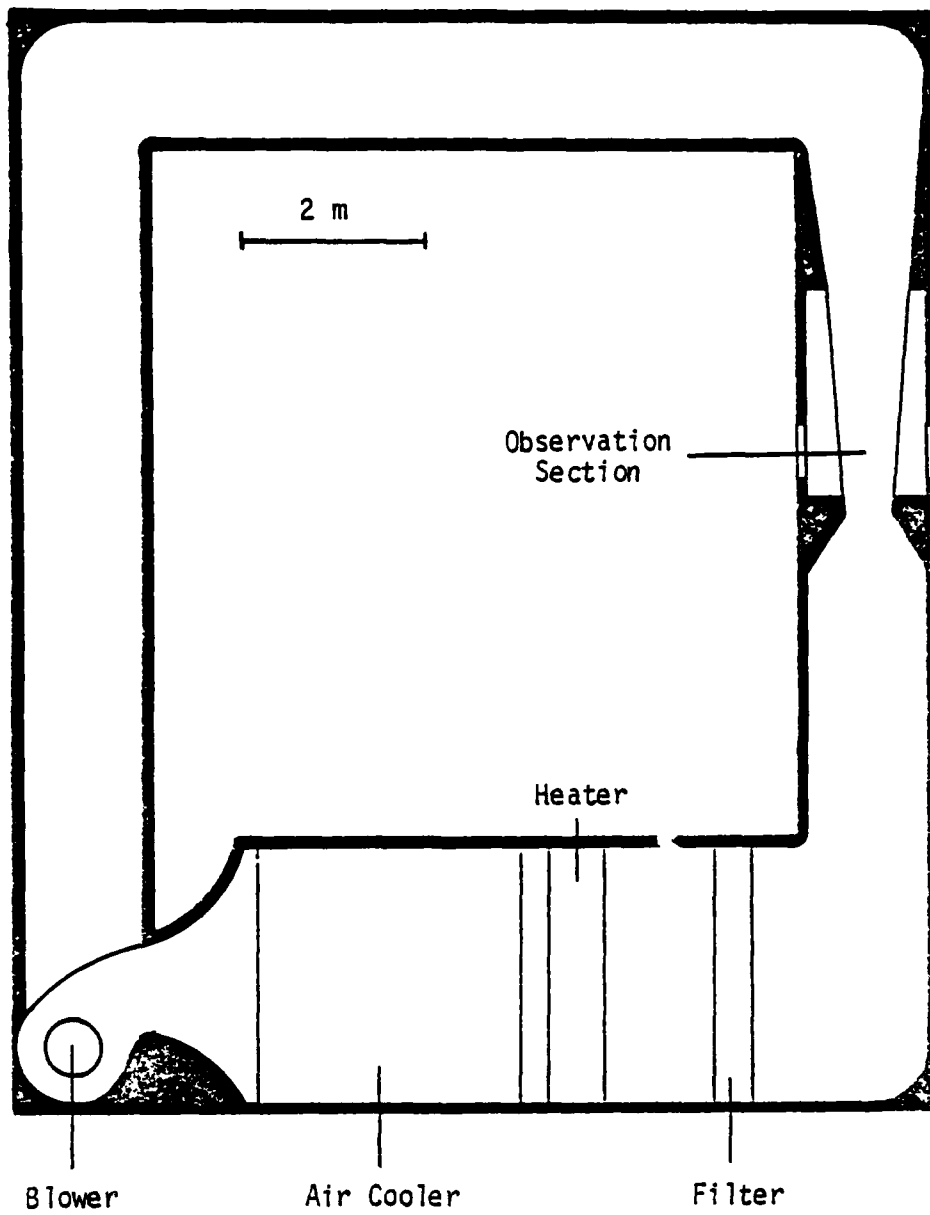

Fig. 3.9. Swiss Hail Tunnel (after List, 1959)

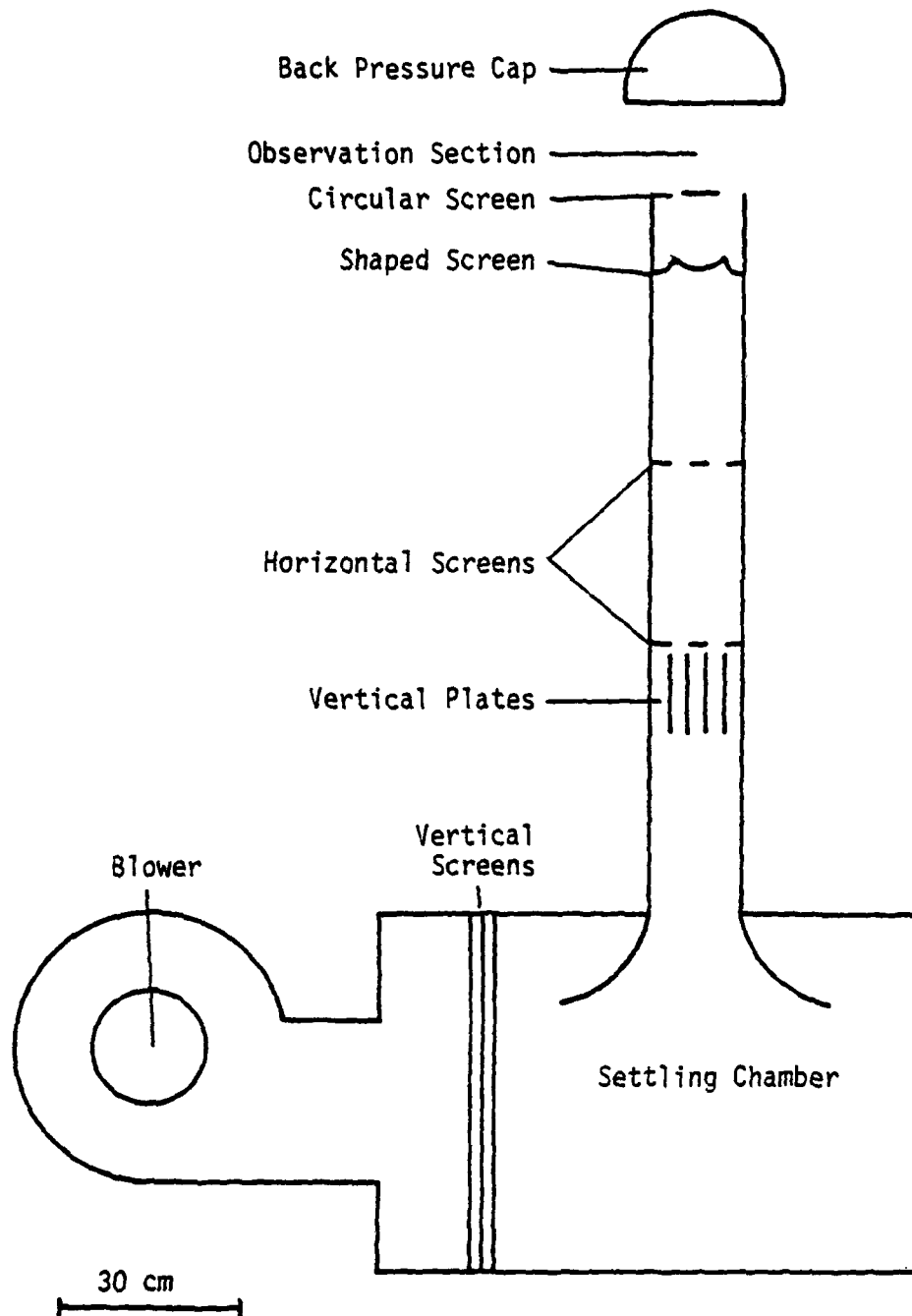

Fig. 3.10. Hydrometer Suspension Apparatus
(after Cotton & Gokhale, 1967)

use of: (1) a shaped screen, (2) rounded corners, (3) a settling chamber which dampens out flow fluctuations introduced by the blower, (4) vertical screens located in the settling chamber which aid in the dampening effect, and (5) a large horn located at the entrance to the vertical section which reduces turbulence. As with Kinzer and Gunn's (1951) apparatus for suspending large drops, the waterdrops are suspended directly above the tunnel. They can be suspended for several seconds without disintegration, but are extremely sensitive to turbulence.

Prior to Hoffer and Mallen (1968), the turbulence and other factors in suspension tunnels had prevented the suspension of droplets smaller than roughly 500 microns in diameter. Their tunnel, shown in Fig. 3.11, can support droplets in the size range of 50 to 200 microns. It consists of three sections: (1) a diffuser, (2) the velocity profile creator, and (3) the observational section. The diffuser expands the airflow slowly from the initial inlet to the inlet diameter of the tunnel. The "heart" of their apparatus is the central section, which develops the velocity profile characteristic of the spin chamber, Fig. 3.6. It consists of a circle of 0.08 cm diameter polyethylene tubes ringed by 0.11 cm tubes and flanked by 100 mesh screening. The observation section is a clear acrylic tube, tapering downwards at an angle of 3 degrees. Airflow is provided by bottled breathing gas, compressed over water (giving pure air). This apparatus has stably suspended 2 mm diameter pith balls (which have about the same mass as a 100 micron diameter droplet) for hours.

The most widely used suspension chamber to date is the UCLA

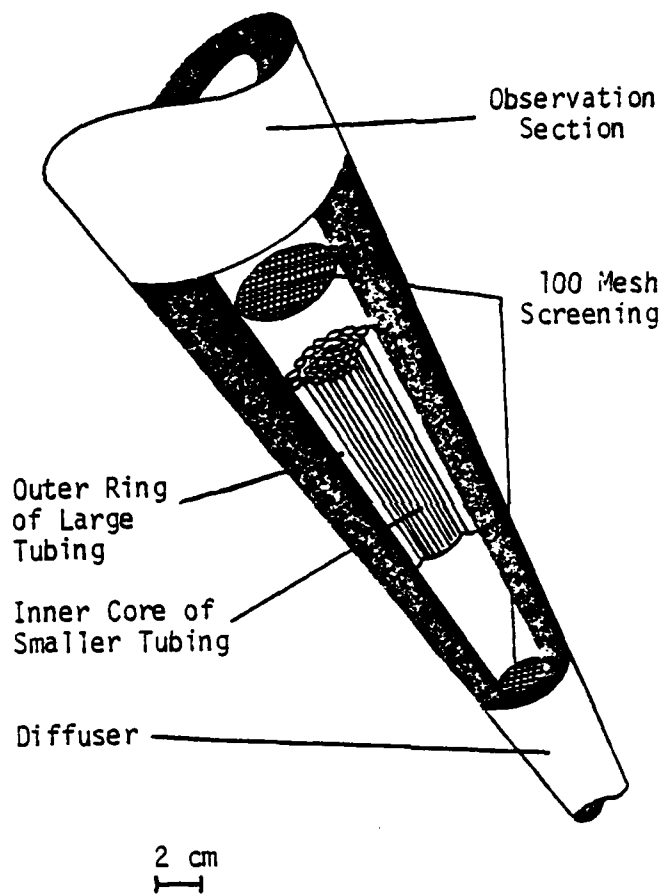

Fig. 3.11. Hydrometer Suspension Apparatus
(after Hoffer & Mallen, 1968)

tunnel (Pruppacher and Neiburger, 1968; Beard and Pruppacher, 1969; Pruppacher and Beard, 1970; Pitter and Pruppacher, 1973; Pflaum and Pruppacher, 1979; Pruppacher and Rasmussen, 1979). Basically, the tunnel (Fig. 3.12) consists of a horizontal air conditioning system and a vertical flow control system. The air is moved through the system by a vacuum pump. The air conditioning system allows control of the air from room temperature to -40°C and 1-100% relative humidity. The flow control system smooths the air by means of a large settling chamber, honeycomb, screens and a contraction section. The airflow is controlled by varying the position of a paraboloidal plug in the tunnel just upstream of the vacuum pump. This allows rapid and accurate control of the air velocity in the observation section. This section is 6 inches square (15.2×15.2 cm) with a divergent upper portion. Large plate glass windows enable viewing and photographing of test objects. The success of this tunnel is attested to by its wide usage.

In 1970, Iribarne and Klemes designed and constructed a closed circuit suspension chamber where drops could be suspended freely (see Fig. 3.13). The blower, powered by a variable speed motor, sends air upward through screens and a honeycomb which minimize turbulence. Just below the divergent observation section, two shaped wire screens, one a 3 cm diameter disc, create an appropriate velocity profile to provide good stability for suspended drops. Filters throughout the system help to keep turbulence at a minimum.

Up to this point the suspension chambers we've discussed were designed and used to support water droplets of various sizes. A water

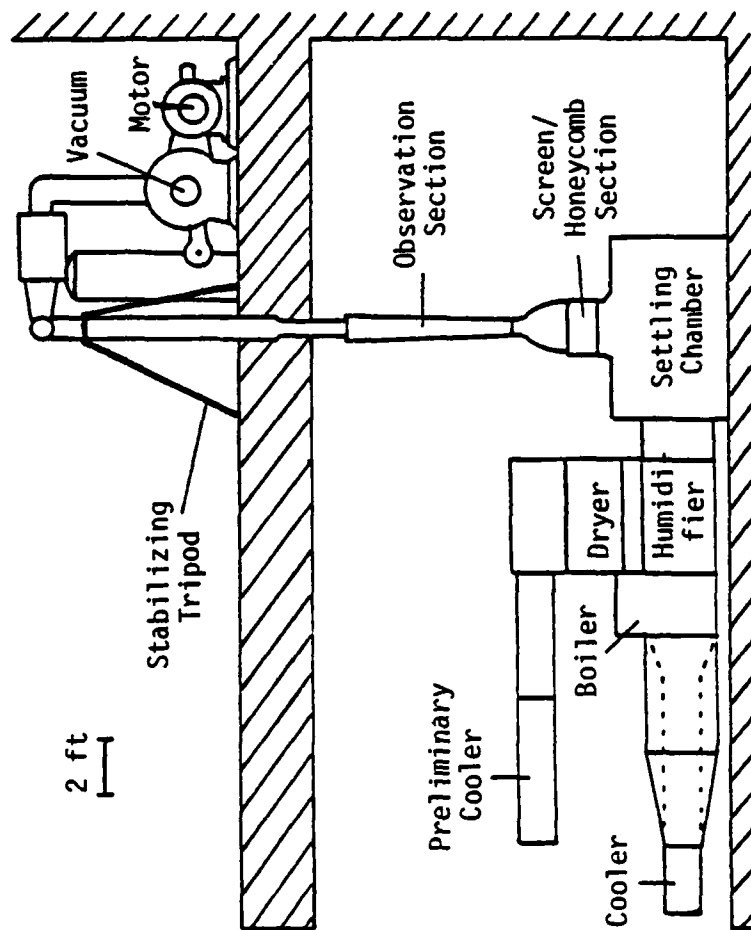

Fig. 3.12. UCLA Hygrometer Suspension Apparatus
(after Pruppacher & Neiburger, 1968)

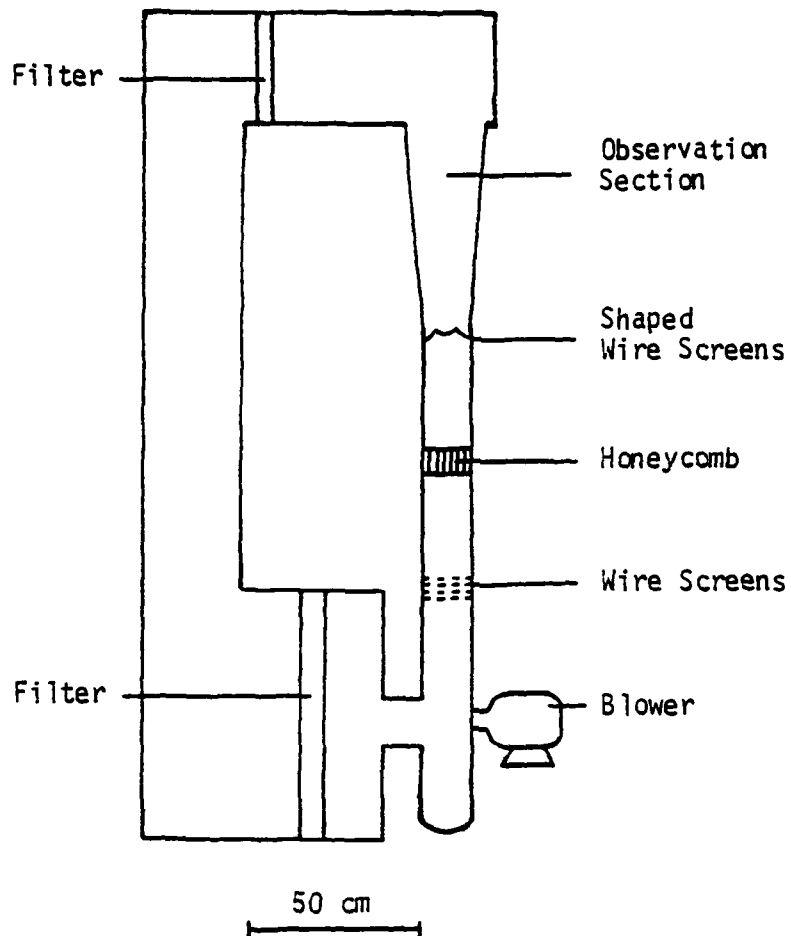

Fig. 3.13. Hydrometer Suspension Apparatus
(after Iribarne & Klemes, 1970)

droplet presents a spherical profile to the air current suspending it while a snow crystal does not. Although some work has been done with the suspension of frozen water droplets (the design and construction of the Swiss hail tunnel, for instance), most researchers have avoided the problems associated with suspending a snow crystal. Pitter and Pruppacher (1973) were two of the first to do extensive research involving the suspension of ice particles. They attempted to use the UCLA hydrometeor suspension apparatus but soon discovered it didn't work because the walls always remained warmer than the airstream, causing enough buoyant flow to destroy the velocity profile. They corrected this problem by inserting a small inner tunnel in the observation section. This tunnel was smaller than the outer one, leaving an air gap between them which allowed the airstream and the inner tunnel walls to remain at the same temperature, thus eliminating the buoyancy problems. The inner tunnel was also flexibly mounted so its axis could be tilted slightly in any direction. They found this aided them in stably suspending a frozen particle for any length of time. Pflaum and Pruppacher (1979) later used this same modification in studying the growth of graupel.

Fukuta, Neubauer and Erickson (1979) were among the first to freely suspend small ice crystals. Their apparatus, shown in Fig. 3.14, was constructed of masonite and was placed in a walk-in cold room. Its horizontal cross-section ($0.5 \times 0.5 \text{ m}^2$) equaled its vertical cross-section. Metal screens and honeycombs were used to reduce turbulence. Airflow through the apparatus was provided by a small vacuum cleaner connected to the top of the vertical section. A variac

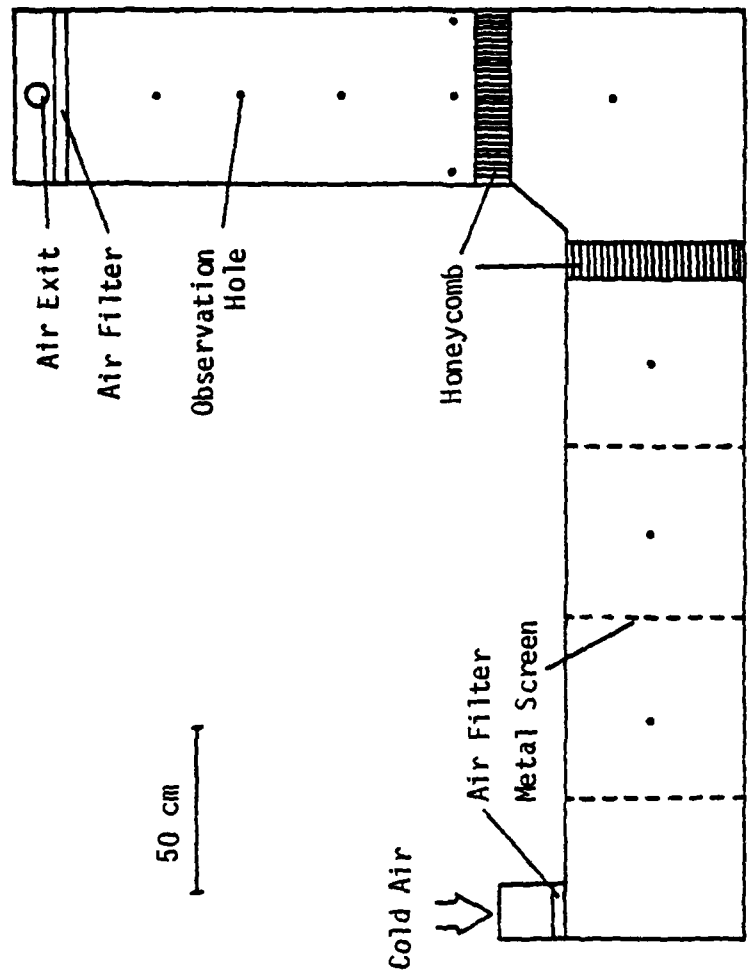

Fig. 3.14. Ice Crystal Suspension Apparatus (after Fukuta, Neubauer & Erickson, 1979)

and a leak valve in the suction line enabled precise control of the velocity in the observation section. With the apparatus, ice crystals were suspended for the study's desired length of time (up to three minutes).

Two of this apparatus' disadvantages, the difficulty of establishing horizontal and vertical stability and the inability to suspend crystals falling faster than about 12 cm s^{-1} , led Kowa (1981) to design and construct a better suspension apparatus (Fig. 3.15). Although also placed in a walk-in cold room, this apparatus had two major differences from the previous equipment. The first, not relevant to our study, was a much larger chamber where supercooled fog could be thoroughly mixed. Second, the observation section, constructed of plexiglass, was made in a convergent design. While the airspeed increased from the bottom to the top, due to the decreasing cross-sectional area and the law of continuity, this proved not to be a problem. Kowa found that due to the relatively slow fall speed of ice crystals, this vertical instability was easily overcome by adjusting the airflow. As the air moves up the convergent section, a velocity peak is developed just inside the chamber walls, thus giving the velocity profile of the spin tunnel (Fig. 3.6). Crystals could be suspended for indefinite periods, at any level in the convergent section.

After reviewing the literature on wind tunnels in general, we made a list of some of the characteristics our apparatus should have. This list was compared to the apparatuses built by others in attempting to freely suspend a hydrometeor. The results, which greatly

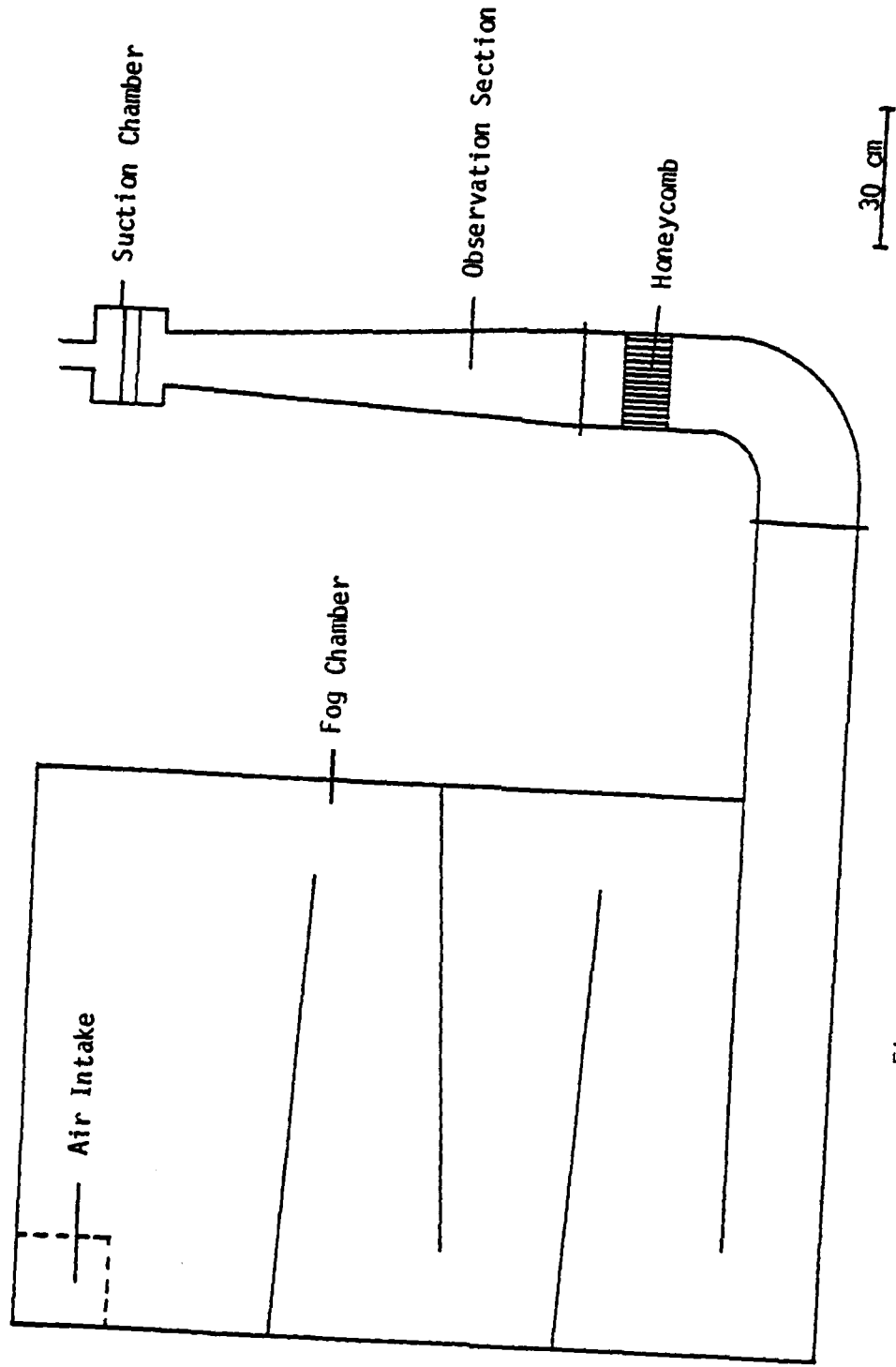

Fig. 3.15. Ice Crystal Suspension Apparatus
(after Kowa, 1981)

influenced our apparatus, are shown in Table 1.

Chapter 4

FINAL DESIGN AND CONSTRUCTION OF APPARATUS

We found the suspension of a particle in a column of air, free of supports, to be a very complex problem, the solution of which is dependent upon many factors. In this chapter, the process of arriving at our final design is detailed, section by section, but it must be pointed out that the sections are all interrelated and changes in the development of individual sections often occurred simultaneously. Figure 4.1 shows the major sections and how they are related (with the exception of the photographic apparatus).

Suspension Section

The suspension section is the "heart" of the entire apparatus, as it is here that the snowflake is actually suspended, observed and melted. In this section, the design and construction of the tunnel, settling chamber, honeycomb, screens, entrance tunnel, insertion tube, and exit are described.

Suspension Chamber

Our first chamber was square, 7.6 cm at the bottom diverging to 12.7 cm at the top, 80 cm high and was made of 3.18 mm thick acrylic sheet. A diverging design was chosen because of the velocity profile, increasing towards the bottom. This would allow the snowflake to automatically find a balancing position in the tunnel. Then, as it

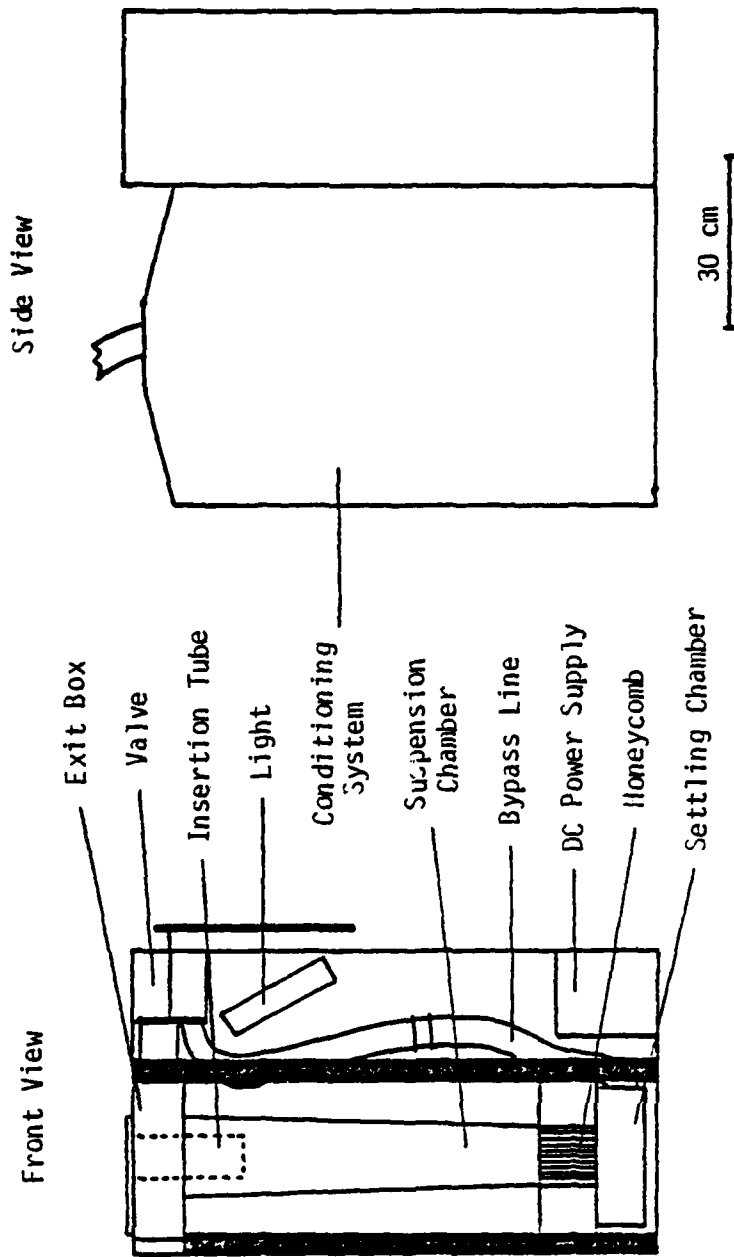

Fig. 4.1. Major Sections of Apparatus

melted, and its fall velocity increased due to its smaller profile, it would slowly settle toward the bottom of the chamber. Depending on its size, an adjustment in the chamber's airflow may not be necessary. Required adjustment, if any, would be small. In this way, the design of the tunnel would simplify the process of adjusting the airflow to hold the snowflake motionless. Hoffer and Mallen (1968) indicated that a taper of less than five degrees results in stable laminar flow for the air velocities used in our study. Upon testing, it was discovered that the increased resistance in the corners as opposed to the center of the walls created "dead spots", or areas of lower velocity. The artificial flake, when dropped into the center of the tunnel, would "slide" down the velocity profile to the wall, and then into a corner, where it would remain unless bounded out. Once bounced out, however, it would go to another wall and corner. Not only was vertical and horizontal stability unachievable, but the damage to a natural snowflake from collision with the chamber walls made this design unacceptable. A solution to the corner problem was achieved by inserting a rolled piece of acetate into the square chamber, which then formed a cone shaped chamber. Stability was achieved and the corner problem was solved. Our velocity profile from the chamber alone was now dome shaped, due to the circular cross-section of the chamber. This approached, but didn't achieve, the velocity profile we required. Our final tunnel dimensions are 60.4 cm high, with a bottom diameter of 9.5 cm diverging to 13.6 cm at the top. This gives a taper of less than 2 degrees in semi-vertical angle. The chamber is constructed of 24 mil cellulose acetate

sheeting and is embedded at both ends in a plate of 6.35 mm acrylic sheeting. Two 3.18 mm thick acrylic rings provide support approximately 10 cm from each end.

To achieve horizontal and vertical stability requires a velocity profile similar to that used in the spin tunnel (see Fig. 3.6). The first step in accomplishing this was to make the airflow laminar. From a review of wind tunnel literature, we learned that turbulence can be removed through the use of a settling chamber (or tunnel contraction), honeycomb and screens.

Settling Chamber

A settling chamber acts to constrict the flow through the tunnel, thus damping out some large scale turbulence. Our settling chamber measures 22 x 30.5 cm and is 8 cm deep. It is constructed of 21 gauge galvanized sheet metal. In our apparatus, we found that the contribution of the settling chamber to the velocity profile was negligible, but it is required to direct the air from the conditioning system to the honeycomb, and on into the suspension chamber.

Honeycomb

Our first honeycomb, from the Hexcel Corp., Dublin, Ca., had 3.18 mm hexagonal shaped cells and was 20 cm deep. After initial success in suspending an artificial snowflake, many different types of honeycombs were constructed trying to achieve a "perfect" velocity profile (as shown in Fig. 3.6). Figure 4.2 shows some of these prototypes with the final honeycomb (right foreground) and the instrument used in making them. The honeycomb is 9.53 cm in diameter, made of 3.18

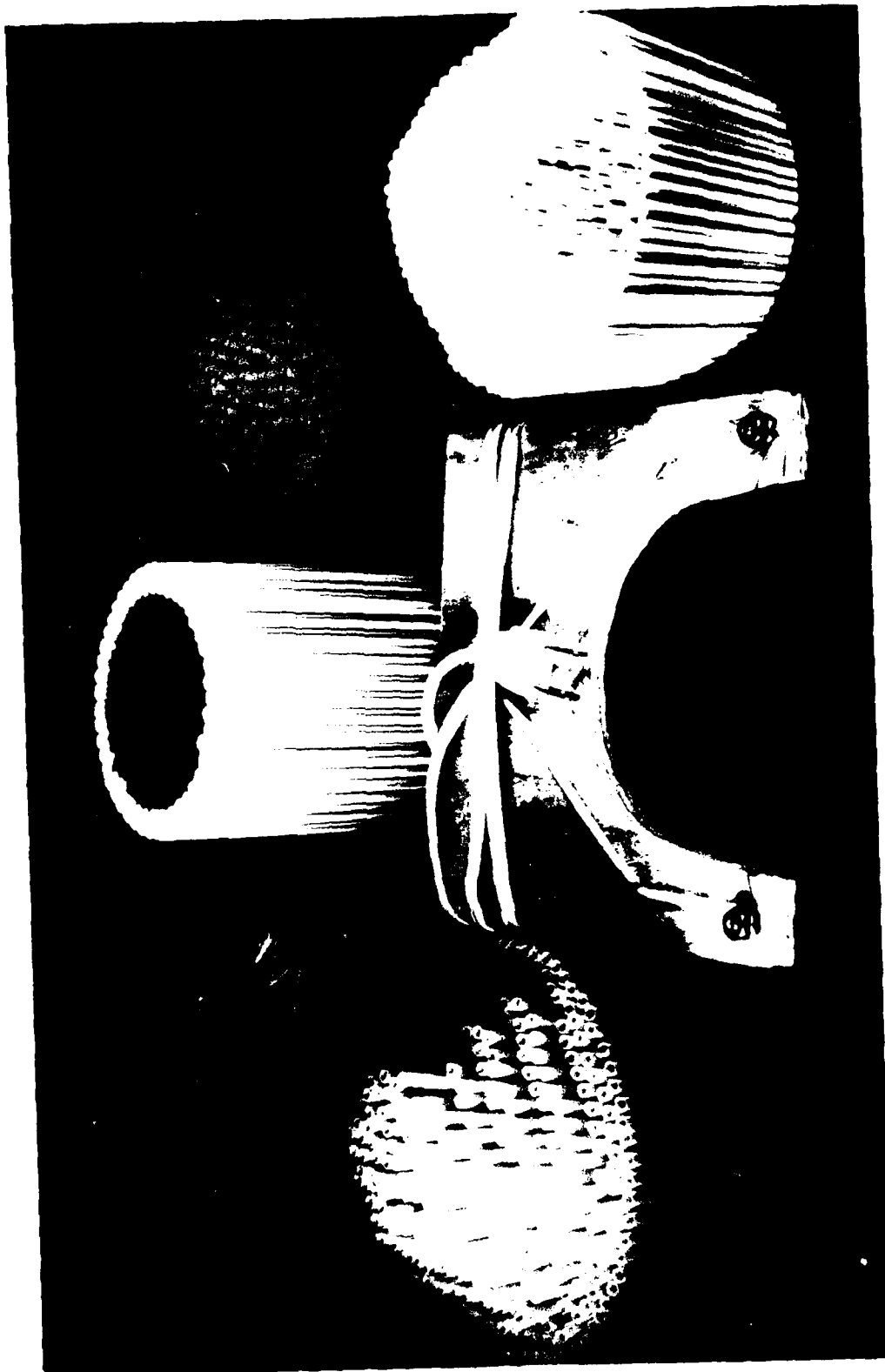

Fig. 4.2. Photograph of Honeycombs and Cutting Device

mm diameter plastic straws, arranged in 12 levels, with the straws varying in length from 6 to 9.4 cm. The straws were arranged in place in a 9.53 cm inside diameter clear acrylic tube, 10 cm long, which was held at each end by a 30 cm square piece of 6.35 mm acrylic sheeting. A device was built in our lab to cut the straws flush with the 30 cm square piece of sheeting. The device consists of a 21 gauge steel wire with a resistance of 0.35 ohms per meter, forming an 11 cm cutting edge, mounted on a piece of plywood. A variac was used to pass 6 volts AC through the wire. The wire was then pushed through the straws, melting them flush with the top of the honeycomb section and sealing them together. This allowed for easy removal of the honeycomb.

While the honeycomb was useful in approximating laminar flow, further modifications in the air stream were required to achieve the desired velocity profile. These modifications were made using screens. The correct configuration of these screens was determined by the trial and error method.

Screens

Pankhurst and Holder (1952) explain that screens act to remove large-scale eddies at the expense of the introduction of a larger number of smaller eddies which are found to decay rapidly. The screen thus decreases the turbulence at a sufficient distance downstream, although it may considerably increase it immediately after the screen. Pope and Harper (1966) state that screens are far more useful than honeycombs for adjusting airflow. Low turbulence wind tunnels may use six or more whereas a regular tunnel will only incorporate one

or two. According to Pope (1954), the spacing between screens doesn't seem to make any difference as long as they don't touch each other. Our screens are made using 18×16 aluminum mesh, mounted on rings constructed of 20 gauge steel wire.

As the air left the honeycomb, there were minor dips in the profile (Fig. 4.3 shows the velocity profile above the honeycomb and above the screen) creating a velocity profile composed of small "domes". After the air passed through the screen, the profile still consisted of "domes", but these were smaller and damped out more quickly than those caused by the honeycomb. Because of this, three layers of screening were used, directly above the honeycomb in our tunnel. The desired velocity profile (as shown in Fig. 3.6) was made by increasing the resistance in the center of the chamber using more screens. These screens (three of them) were created by marking a circular center section on the mesh and then removing the excess wire strands. The remaining strands were arranged in the radial direction, evenly spaced and attached to the ring with epoxy glue. To prevent rust, the rings and mesh were spray painted black (this also gave a darker background to reduce light reflection in the chamber) and the rings further coated with polyurethane paint. A velocity profile whose center dip was too shallow allowed the artificial snowflake to work its way up the side until gravity pulled it down. It would cross the bottom of this velocity "dish" and climb higher on the opposite side. By continuing this process, the artificial snowflake would soon climb over the side of the velocity "dish" and impact with the suspension chamber wall. If the velocity profile's sides were

Velocity Profile
at Distance X
Above Screen



Screen



Velocity Profile
at Distance X
Above Honeycomb



Honeycomb



Airflow



Fig. 4.3. Velocity Profiles

too high, the horizontal velocity gradient was too strong. As the artificial flake drifted out of the bottom of the "dish", the gradient would push the side of the snowflake up and over, causing it to tumble (instead of simply sliding back). Once the flake began tumbling, it would bounce into areas of stronger upward velocity (further from the chamber centerline) and soon be thrown completely out of the velocity "dish" and again impact with the wall. The exact dimensions and number of "molding" screens (those designed to properly shape the laminar flow) were determined experimentally, by the trial and error method. Figure 4.4 shows the screens used and their order of placement in the suspension chamber, beginning with the upper left. The height of the screens above the bottom of the tunnel is as follows:

first	0 cm
second	3.6
third	8.0
fourth	10.6
fifth	13.0
sixth	14.1
seventh	15.9

It is interesting to note that the best results were achieved by placing, bottom to top, the middle, small then large screen, and not the small, middle and large as one might expect.

Entrance Tunnel

To enable our apparatus to take measurements during windy conditions, an entrance tunnel was constructed based on Zikmunda and Vali's (1972) experiences. This tunnel was constructed of heavy wire mesh rolled to form a cylinder 24 cm in diameter, 91.4 cm high and covered with 1.5 mil plastic. This cylinder was anchored to a wooden base, to enable it to stand alone, and positioned outside the shelter, above

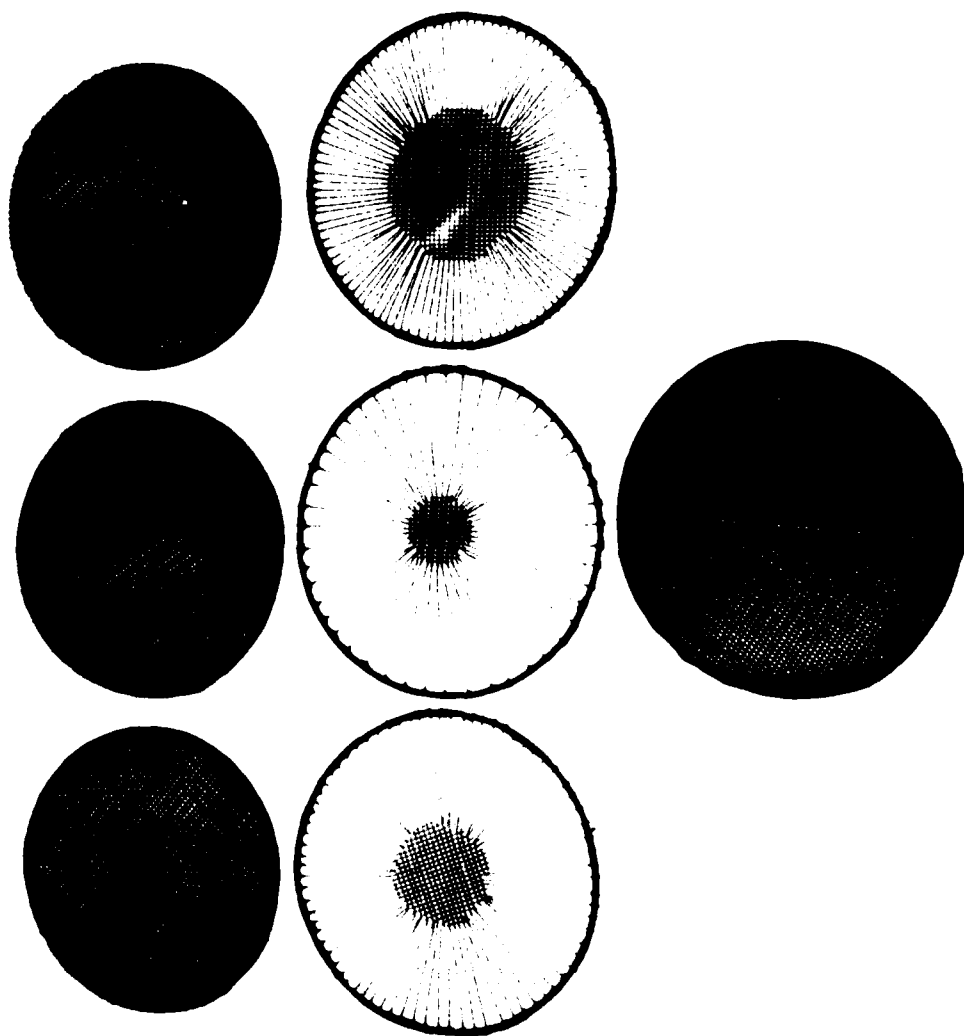

Fig. 4.4. Photograph of Screens

the suspension chamber. This tunnel and its positioning can be seen in Fig. 4.23. The tunnel is deep enough to enable a snowflake, being blown almost horizontally into it, to regain its fall velocity and fall vertically into the suspension chamber, thus allowing measurements under windy conditions. Construction and positioning of the tunnel was done in such a way as to minimize or eliminate air drafts from the base which could affect the falling snowflake. On the top of this tunnel opening controls (3 removable covers with center holes 3 to 15 cm in diameter) can be attached. Depending on the intensity of the snowfall, these allow finer control on the number of snowflakes entering the suspension chamber.

Insertion Tube

The snowflake, after falling through the entrance tunnel, reaches the top of the suspension chamber, where the air exit for the chamber is located. This is an area of great turbulence, which could cause the snowflake to be thrown against the chamber wall and be damaged. To help the snowflake to fall past this area, an insertion tube was designed and constructed (Fig. 4.5). This consists of a 6.35 cm inside diameter clear acrylic tube which extends 23 cm down into the suspension chamber. This allows the snowflake to pass through the high turbulence area undisturbed. There is some turbulence at the bottom of this insertion tube, but not enough to adversely affect the snowflake before it falls into the velocity profile and obtains stability. The entrance to this insertion tube is a 2.5 cm diameter opening which extends to the diameter of the tube in approximately 11 cm. This acts to center the snowflake in the insertion tube, thus

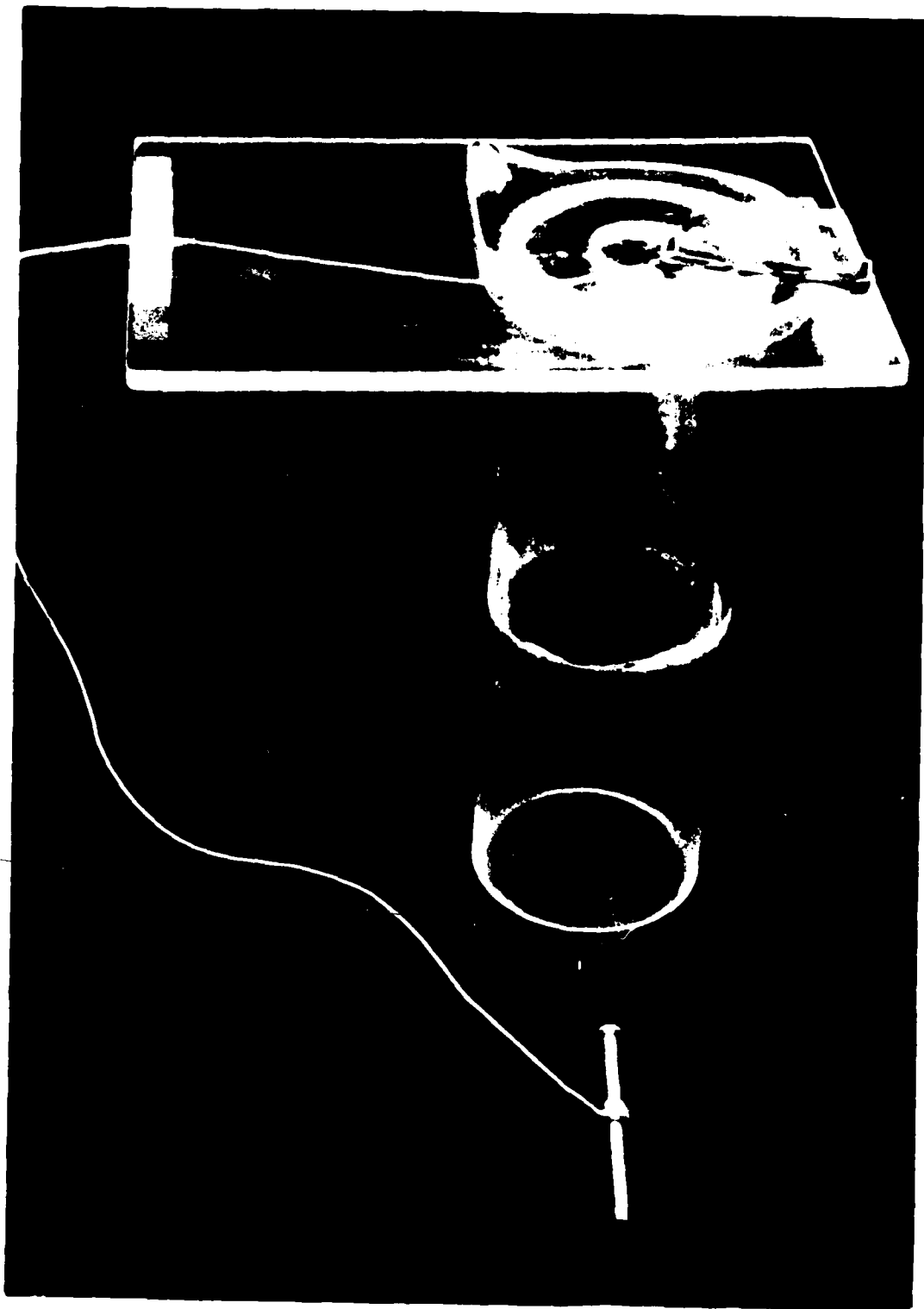

Fig. 4.5. Photograph of Insertion Tube

preventing collisions with the wall. The top opening has a spring-loaded cover which is opened by pulling a cable, the end of which is located at the front left side of the suspension chamber. As soon as a snowflake has entered the chamber and achieved stability, the cable is released and the entrance closes. Air is now able to enter the chamber only through the conditioning system.

Exit

A special exit (shown in Fig. 4.6 with the top removed) was designed and constructed to enable the air to exit smoothly from the suspension chamber and to preserve the velocity profile as long as possible. This section is 30 cm square, 11 cm high and is connected with the valve by a 4.08 cm inside diameter clear acrylic tube. Inside this box is a 15 cm diameter clear acrylic tube, which is sealed to the top and bottom of the box. The bottom of the box is cut away inside this tube and the top has a rubber seal which the insertion tube fits down through. This 15 cm diameter tube has 500 3.18 mm diameter holes, spaced 6 mm apart, perforating it. To leave the suspension chamber, the air must pass through these holes, into the valve and then the vacuum. To insure a symmetrical airflow, this 15 cm diameter tube is backed by a 1.27 cm layer of foam rubber. This slows the airflow, creating an area of lower pressure in the box, which in turn causes the air to be drawn from the suspension chamber symmetrically, rather than favoring the area where the tube to the valve is located. This symmetrical exit of the air, combined with the center "dead spot" from the insertion tube (because no air is passing through this when the top is closed), tends to enhance the velocity



Fig. 4.6. Photograph of Suspension Chamber Exit

profile in the suspension chamber.

Suction System

Vacuum and Power Source

The suction for our apparatus is provided by a Sears, Roebuck and Company 16 gallon Wet-Dry Shop Vac. This vacuum provides more than adequate flow rates for this study and, as noted by Kowa (1981), is rugged enough to withstand cold temperatures for long periods of time. In addition, it met the portability requirements of our study and attachments and replacement parts are readily available. A variac was used to reduce the suction of the vacuum so that the airflow in the suspension chamber fell within the range suitable for suspending snowflakes. The voltage to the vacuum was reduced to 44 volts. The power for our entire apparatus was provided by a portable alternator sold by Sears, Roebuck and Company, model number 560.327120 (2600 watts) (seen in Fig. 4.23). This unit provided ample power to meet our needs. It was easily handled by two people and operated well in the adverse weather conditions in which we carried out our measurements.

Valve

Final critical control of the suspension chamber air velocity is provided by a valve designed and constructed in our lab. This valve is located directly outside the exit portion of the suspension chamber, thereby minimizing the lag time between valve adjustment and the corresponding velocity change in the chamber. The valve is constructed of a 10.8 cm section of clear acrylic tubing with inside diameter of

14.6 cm and outside diameter 15.24 cm. The intake (exit for suspension chamber) is made of a 10 cm section of clear acrylic tubing with outside diameter of 5.72 cm. The bypass tubing (coming from the settling chamber) is a section of 6.35 cm diameter vacuum hose and connects to the valve next to the intake, previously mentioned. The actual openings into the valve for both of these tubes are holes 3.34 cm in diameter. These holes are arranged so that as the cover plate (made of polyethylene to slide easily) inside the valve is rotated, the amount of air allowed to enter the valve remains constant. For example, when the bypass hole is uncovered, the intake hole is covered. As the bypass hole is blocked, the intake hole is opened by an equal amount, so that when the bypass hole is completely covered, the intake hole is completely open. This ensures that the vacuum is drawing an equal volume of air at all times, thus the motor speed is constant and there is no strain placed on the vacuum. The flow rate of air drawn through the conditioning system also remains constant which reduces variations in the relative humidity and temperature of the air. A steel shaft, attached to the cover plate, extends through the top of the valve and outside the enclosing box. The attached handle (56 cm long) enables the cover plate to be easily rotated, thereby controlling the air velocity within the suspension chamber. The valve was designed so that an upward movement of the handle results in increased airflow and the snowflake moves upward in the suspension chamber; a downward movement of the handle and it moves down. This contributes to the ease of operation of the apparatus. The valve is shown in Fig. 4.7.



Fig. 4.7. Photograph of Valve with Anemometer Probe

Conditioning System

The original design of our apparatus called for the air to be recirculated, thus giving precise control over the relative humidity and temperature. Upon actually testing this system though, two serious problems appeared: vibration and heating, both caused by the suction system. The vacuum motor produced a low frequency vibration of the air, which caused the artificial snowflake to bounce uncontrollably inside the tunnel. Through the use of an air vibration damper, the vibration effect was suppressed but could not be eliminated. The motor also produced such heat that the suspension chamber temperature was raised 20°C in 20 minutes (7°C in the first 2 minutes alone). Upon evaluation, the design of an apparatus to overcome these problems was felt to be more formidable, time consuming and bulky than another method of simply conditioning the air and passing it through the entire system one time only. Our new design draws the air through a heater, which allows precise temperature control. The temperature of the environmental air remains constant over our time of observation. This, combined with a constant heating and airflow rate, allows precise temperature control in the suspension chamber.

Heater

The heater measures 44 × 55 cm including a frame constructed of 1 × 2 in (2.5 × 5.12 cm) pine. Thirty gauge aluminum wire with a resistance of 11 ohms per meter is strung in the frame. The actual area spanned by the wire is 40 × 46 cm. Calculations (Appendix A) showed this would give a 15°C rise in temperature; however, the actual

operation gave only a 3.4°C increase. This was due to heat loss from convection over the heater and absorption by the metal walls of the conditioning system. The convection problem was solved by placing a cover over the heater and placing holes in it whose cross-sectional areas combined to equal the cross-sectional area at the bottom of the suspension chamber (Fig. 4.8). Thus the air velocity through these holes was sufficient to overcome convection. Over this cover is another box which draws outside air through a 6.35 cm diameter flexible tube. Absorption by the metal walls of the conditioning system could not be controlled, but the heat loss from these walls was minimized by insulating them with 1.9 cm thick styrofoam sheeting (seen in Fig. 4.9) and enclosing the entire apparatus inside a shelter (Fig. 4.23) to shield it from the environment. The capability of the heater was also increased by stringing more wire. These modifications enabled the heater to perform satisfactorily throughout the study.

Humidifier

In our final design, an evaporative cooler controls the relative humidity of the air entering the suspension chamber. Once the air sample has passed through the heater, it can be directed into the humidifying section, bypass this and go directly to the settling chamber or any combination of these two. This allows the study of snowflake melting in a wide range of relative humidity conditions.

The humidifying section comprises the bulk of the conditioning system (Fig. 4.10), which measures 44 × 55 cm and is 79 cm high. It has three layers, each one composed of two layers of evaporative cooler batting. The system holds 3.3 gallons (12.5 liters) of water.



Fig. 4.8. Photograph of Heater and Cover

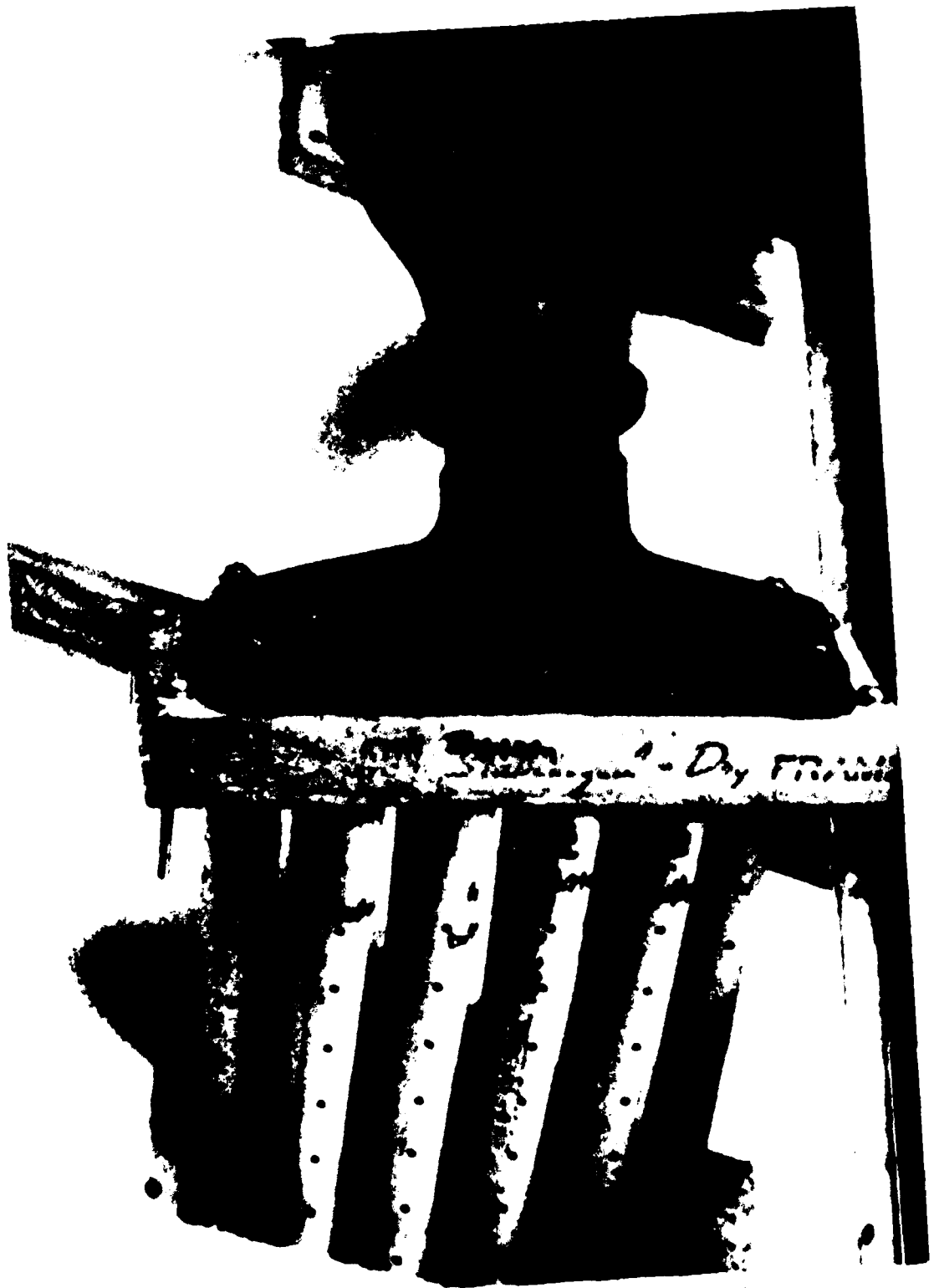

Fig. 4.9. Photograph of Air Distribution Device

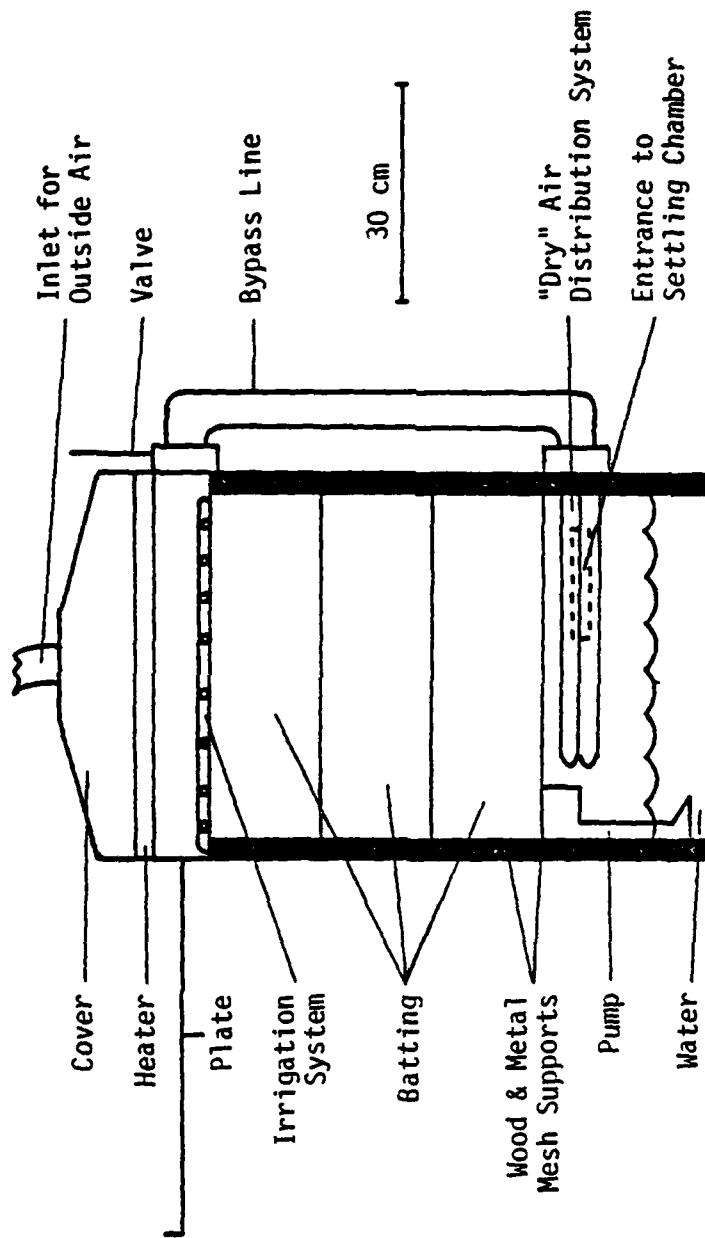

Fig. 4.10. Conditioning System

After running for several minutes (allowing time for the batting to become saturated), this leaves 8.6 cm of water standing in the bottom. The batting is held in place by 0.5 in (1.3 cm) wire mesh, supported by pine corner posts and plexiglass crossmembers.

The irrigation system is made up of a standard 115 V evaporative cooler pump, 20 cm in height. The water is distributed through an irrigation system comprised of 2.5 m of 6.35 mm diameter rubber hose, with an outlet, 0.81 mm in diameter, spaced every 3.8 cm. This system spreads the water evenly over the top layer of batting where gravity draws it back to the pump, wetting the batting in between. This system is very effective in helping achieve maximum practical relative humidity.

Above the irrigation system are mounted supports on which a metal cover slides. This metal cover is operated in conjunction with a valve in the bypass line. When the metal cover is closed over the irrigation system and the bypass valve is opened, the air in the settling chamber comes directly from the heater, i.e., no moisture has been added. This air's relative humidity is representative of the air beneath a storm cloud just before or at the beginning of snowfall. As the snowfall continues, melting snow evaporates in the air, raising the relative humidity. This condition can be reflected in the chamber by sliding back the metal cover. Now air is drawn through both the humidifying section and the bypass line. Operation of the bypass valve will control the relative humidity of the air entering the settling chamber. To insure thorough mixing of this "dry" air with air passing through the humidifier, a special diffusing system was

constructed (Fig. 4.9). The "dry" air exits the bypass line through ten 2.54 cm diameter polyvinyl chloride (PVC) pipes, each 38 cm long and containing thirty-six 3.18 mm diameter holes. The humidified air passes around these tubes prior to being drawn into the settling chamber. This system allows both control over the air's relative humidity and insures thorough mixing of the two air samples. The final storm condition (that relative humidity level achieved after snowfall has been occurring for quite some time) can be represented in the chamber by closing the bypass valve completely, thus forcing all the air through the humidifying section.

Photographic Apparatus

Prototype

Photography plays an important part in our study, for the determination of fall velocity and identification of type and changes in the snowflake during the melting process. As mentioned earlier in Chapter 2, we originally planned the photographic section of our apparatus to be an integral portion of the entire equipment, but later decided to make it removable. This allowed construction and testing of the photographic section before the entire apparatus was complete. The completed instrument is diagrammed in Fig. 4.11. As the snowflake falls into the entrance tunnel, it is seen against a black background through the plexiglass window and the camera shutter is opened for approximately three seconds. An Olympus 35 mm camera, with a 50 mm lens and 14 mm extension tube, loaded with Ilford 400 ASA film was used. The film was exposed at 1600 ASA, then pushed to 3200 ASA when

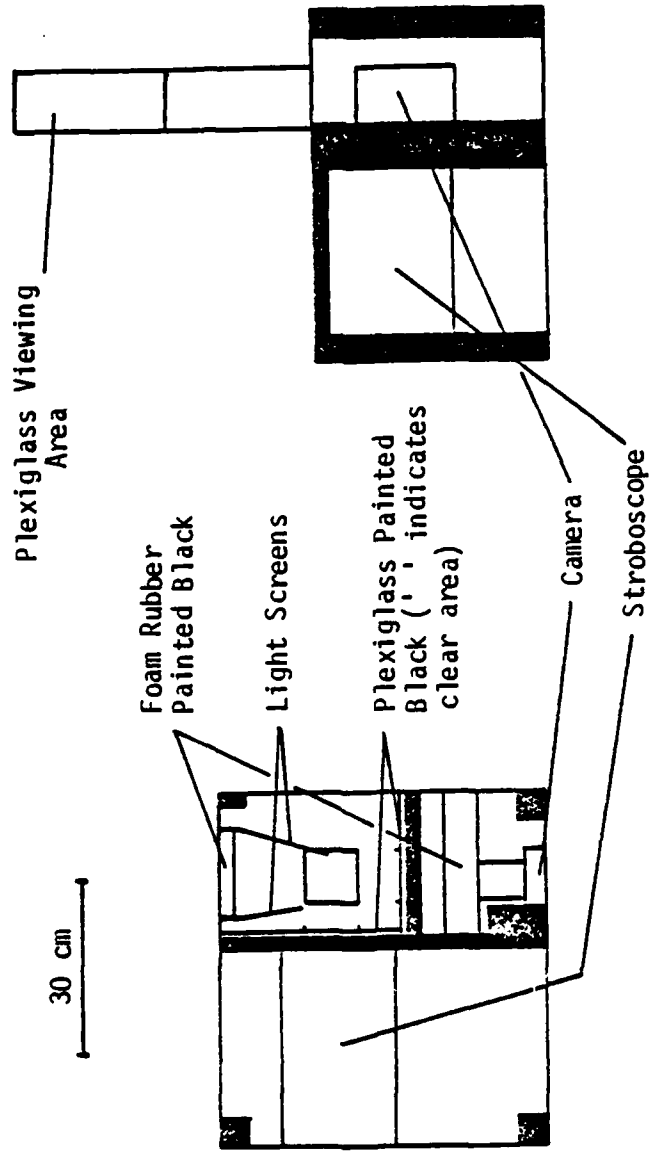

Fig. 4.11. Photographic Section

developed. An example of the images obtained can be seen in Figs. 5.5 and 5.6. When it comes into camera view, the snowflake is illuminated by the stroboscope. By placing the stroboscope 90 degrees to the camera viewing axis and using screens, this darkfield illumination technique allowed an accurate determination of the snowflake's position with respect to time. Determination of the fall velocity is explained in Chapter 5.

While the photographic section enabled an accurate determination of the fall velocity, the problem of "tracking" an individual snowflake through this section and into the suspension chamber still existed. After much consideration, it was felt that since the snowflake would in the end be suspended on a column of air, the fall velocity could be measured from there (i.e., the velocity of the air required to suspend the snowflake is the fall velocity of that flake). This greatly simplified the entire procedure.

Final Design

The final photographic apparatus, and its position in relation to the suspension chamber, are shown in Figs. 4.12 and 4.13. Through the use of a common shutter release, designed and constructed in our lab, both the cameras are activated and a timing mark, seen in Fig. 5.2, is placed on the recorder simultaneously. This camera arrangement gives a top and side view of the snowflake at desired intervals throughout the melting process. The cameras are Olympus OM-2 35mm cameras, equipped with Zuiko 50mm F1.8 lenses. To provide further enlargement of the snowflake, the top camera uses a 14 mm extension tube and the bottom a 7 mm one. The cameras are further equipped with

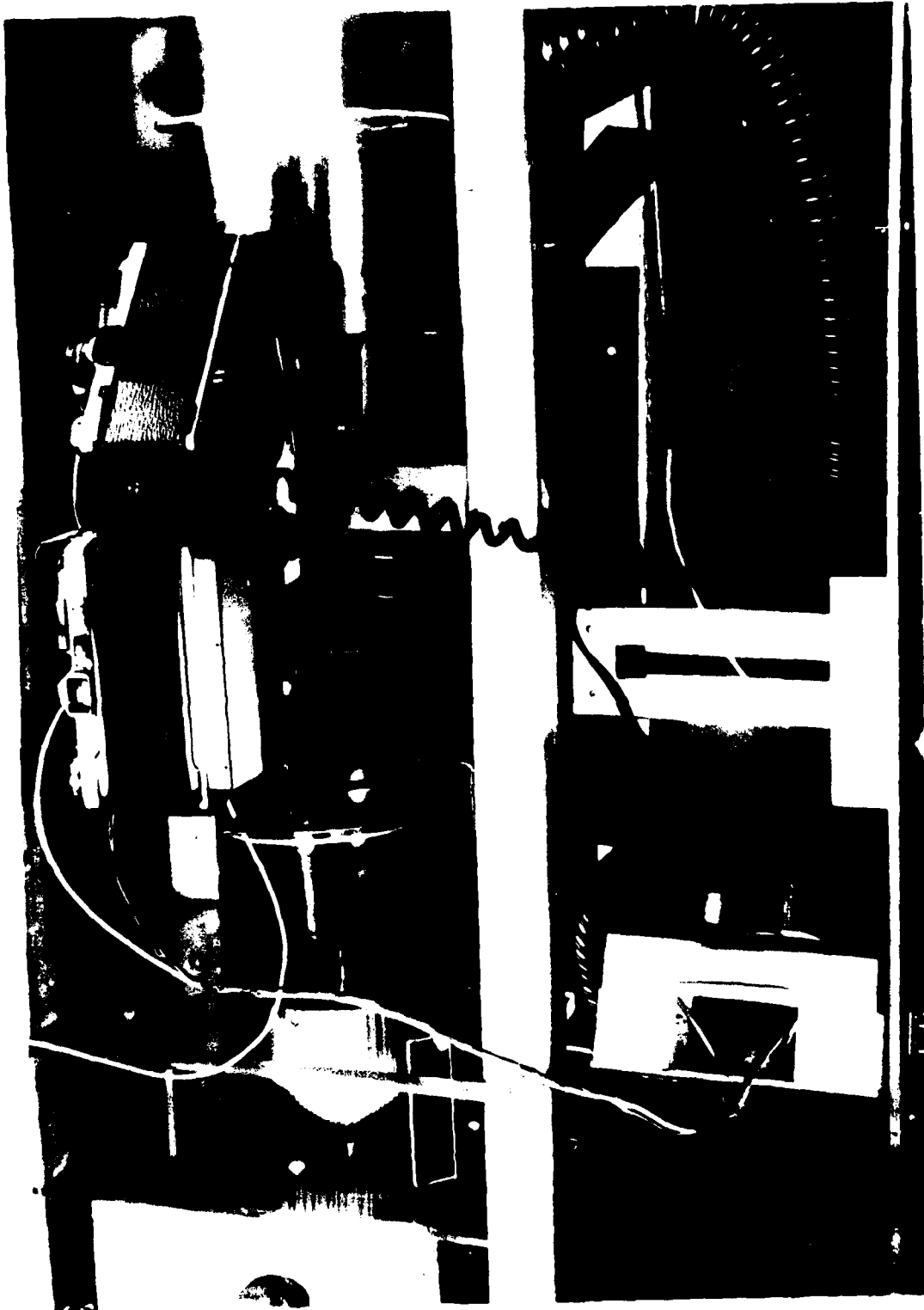
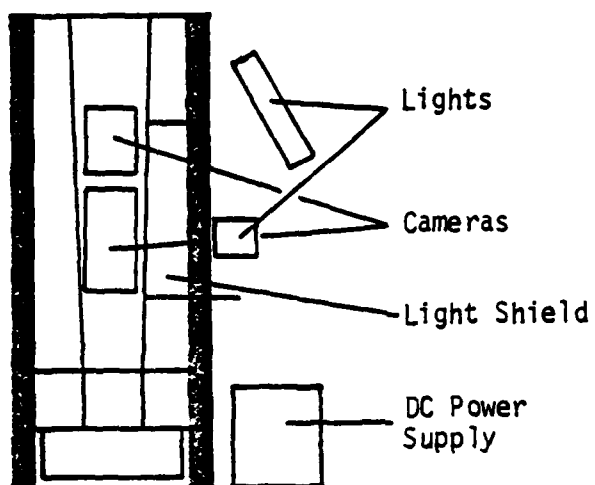

Fig. 4.12. Photograph of Photographic Apparatus

Front View



Side View

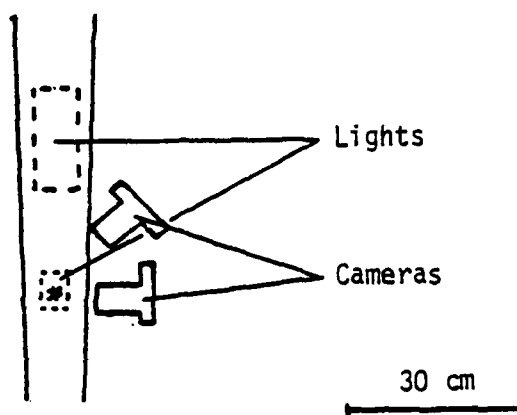

Fig. 4.13. Photographic Apparatus

Olympus Winder 2s, to aid in ease of operation. Ilford HP5, ASA 400 film is used in the cameras. The background lighting is provided by a quartz-halogen automobile driving light. A ten ampere battery charger, model number 608.718331, sold by Sears, Roebuck and Company, powers this light. Further lighting is provided by an Olympus T32 electronic flash, connected electrically to the top camera and positioned as shown in Figs. 4.12 and 4.13. The Olympus camera, when operated in the Auto mode, as we did, reads the amount of light reaching the film surface and closes the shutter when the film has been properly exposed. When the flash is used, it must be kept at a minimum distance or the film will be overexposed (because the camera can't react quickly enough to close the shutter). At that minimum distance, the recharge time of the flash, with its AC adapter, was about 12 seconds, much slower than desired. We found that we could move the flash closer, and by "fooling" the camera into thinking it had 1600 ASA film, get a proper exposure on our 400 ASA film and a recharge capability of the flash of approximately 1 second. To reduce glare on the suspension chamber, the light is funneled through a tin chamber, painted black to reduce reflections, with an opening, 30 cm high, ranging in width from 3.8 cm at the bottom to 5.7 cm at the top. Black paper was also placed on the outside of the suspension chamber to aid in reducing reflections. Examples of the photographs obtained are shown in Figs. 5.3, 5.4 and 6.1.

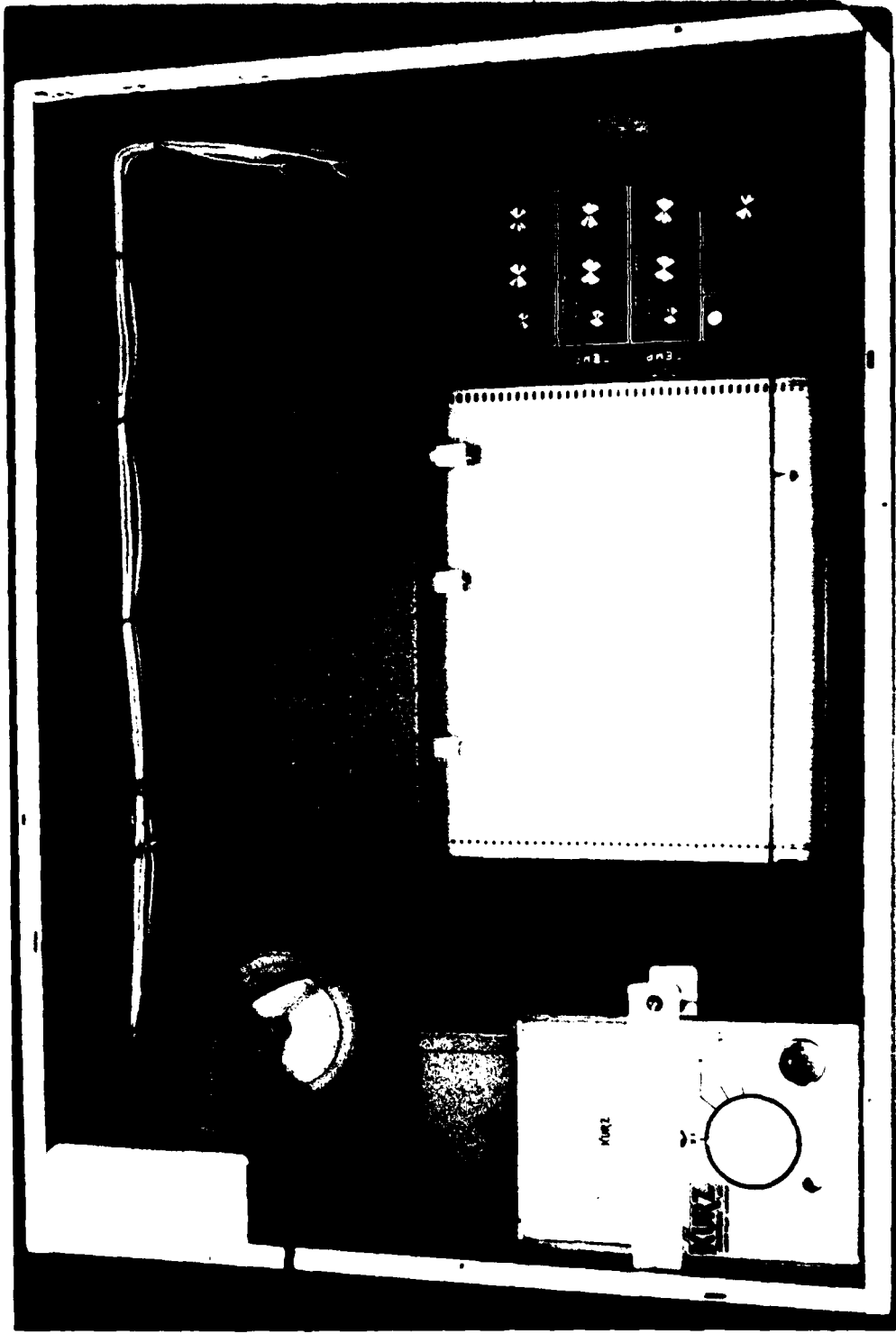

Fig. 4.14. Photograph of Instrument Box

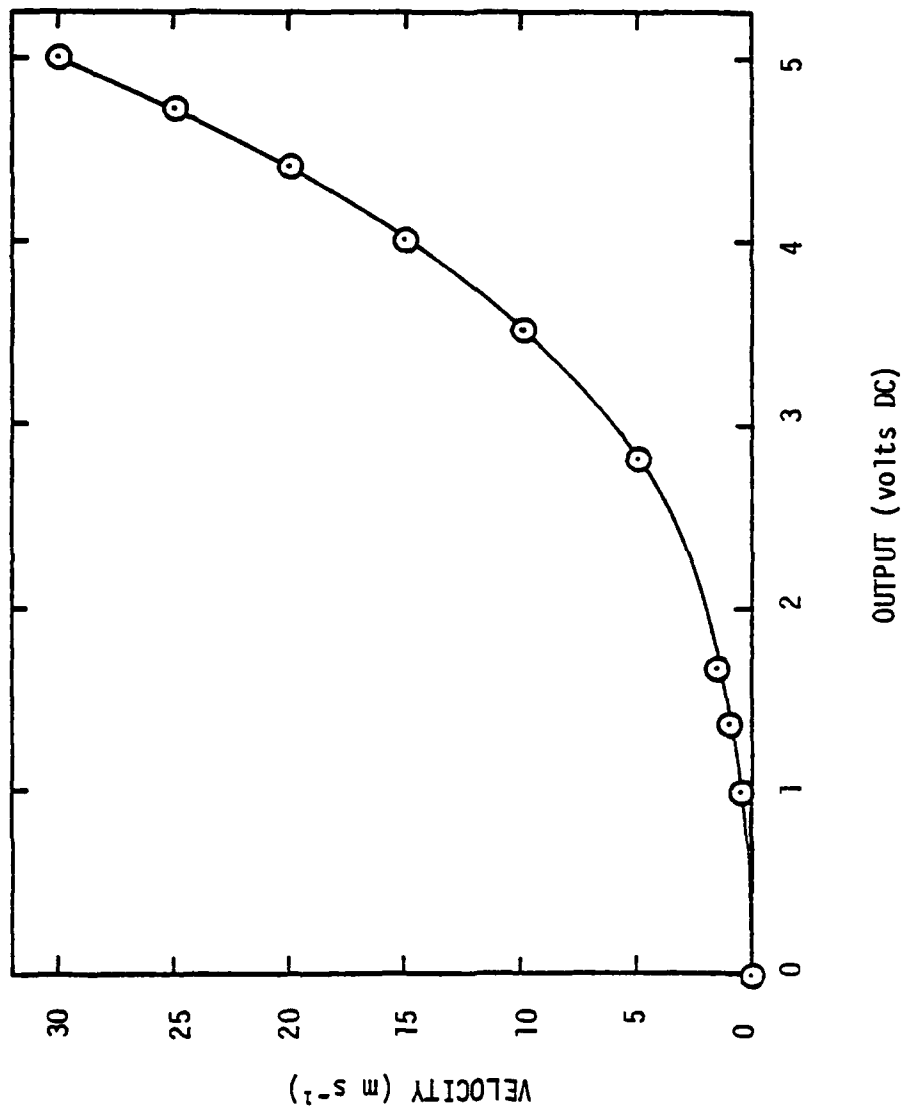

Fig. 4.15. Anemometer Calibration Curve

This spans only a portion of the scale. We felt it would be better to use more of the scale. The insertion of the probe into the suspension chamber itself presented turbulence problems. The velocity profile required was so delicate that interference from the probe would have been unacceptable, thus the probe couldn't be located upstream of the desired suspension point. A downstream location presented an obstacle to the snowflake falling unobstructed into the chamber. Also, because of the velocity profile, placement of the probe for an accurate velocity measurement would be very important. With the location we chose, we were able to record an average velocity. Because of the divergent design of the suspension chamber, the velocity decreased toward the top. To aid in determination of the actual fall velocity, six horizontal reference lines were placed on the suspension chamber, 2.54 cm apart, beginning 18.4 cm above the bottom of the chamber. These lines, in conjunction with a photograph, allow an exact determination of the fall velocity. This procedure is explained in Appendix F. The error induced by the anemometer/recorder combination is 1.18%, as described in Appendix B.

Hygrometer

Determination of the relative humidity is made using an instrument designed and constructed in our lab, shown in Fig. 4.16. The mirrored container holds ether, which is cooled by evaporation as the rubber bulb is squeezed, forcing air up through it. When the ether cools the container to the dewpoint temperature, condensation will form on the mirrored surface. This is very noticeable with the aid of the uncooled mirrored fins on either side. The exact dewpoint

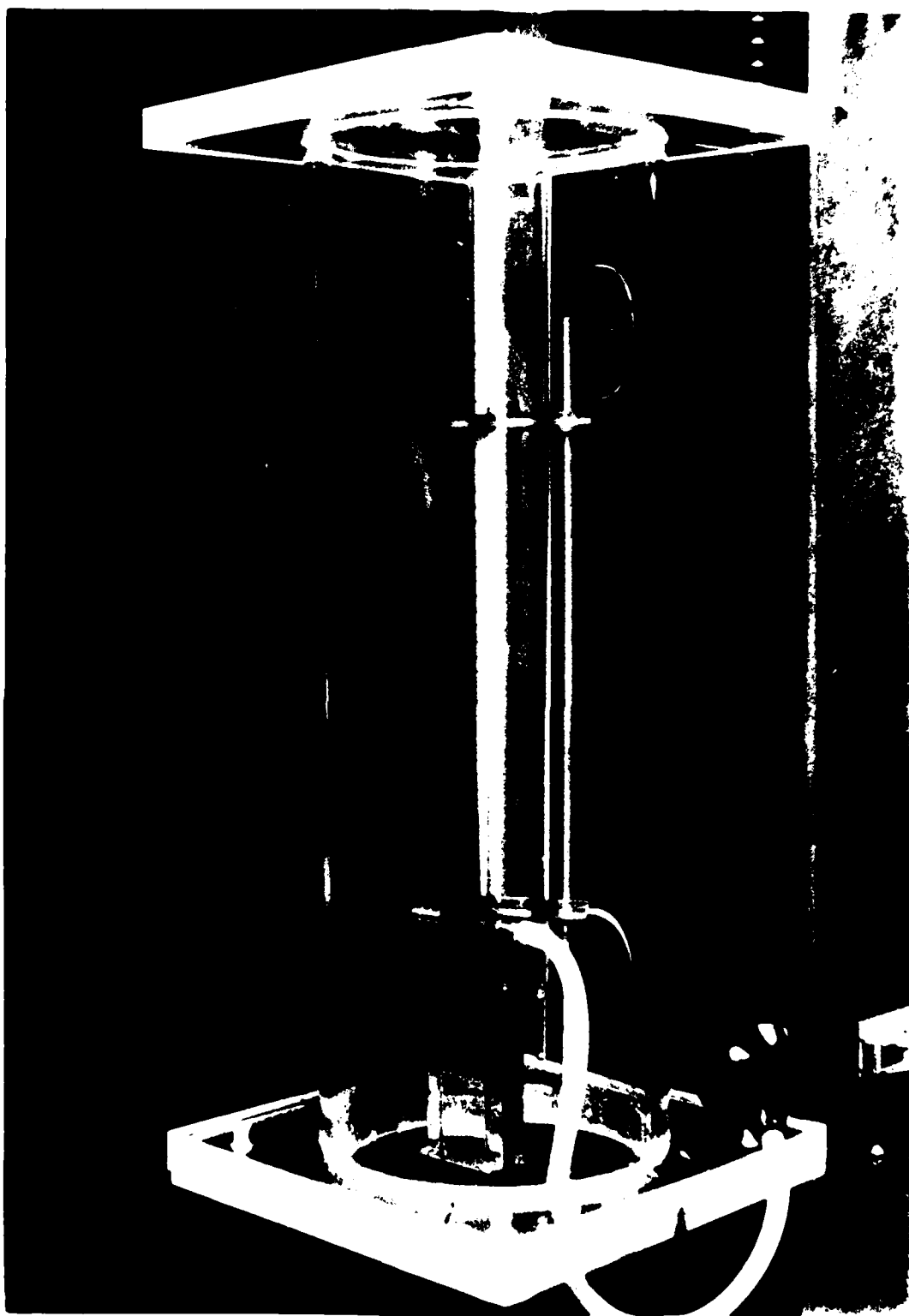

Fig. 4.16. Photograph of Hygrometer

and ambient air temperatures are measured by two thermometers, graduated in one tenth degree intervals. Their calibration curves, as compared with a National Bureau of Standards corrected thermometer, are shown in Fig. 4.17. This entire apparatus is enclosed in a 15.24 cm diameter clear acrylic tube with the ends capped. Two holes, one close to the top and the other to the bottom, allow this instrument to be connected into the bypass line leading from the settling chamber to the valve. Thus the exact dewpoint and ambient temperature of the air in our suspension chamber can be determined after it has passed through the conditioning system. With these temperatures, the relative humidity is calculated.

Air Temperature

The temperatures, both outside and inside the apparatus, are measured by two thermocouples, constructed from type T, 20 gauge copper constantan wire. The calibration curves for the inside and outside thermocouples are shown in Figs. 4.18 and 4.19, respectively. The inside thermocouple is located in the settling chamber (Fig. 4.20), thus insuring that the temperature measured is that of the air in the suspension chamber and minimizing any turbulence which may be created by the thermocouple. The thermocouple measuring the outside air temperature extends through the shelter wall approximately 76 cm and is protected from falling snowflakes by a cover. It can be seen in Fig. 4.23.

Artificial Snowflakes

In building our apparatus, it was important to find, or design,

AIR TEMPERATURE (THERMOMETER # 7K2145)

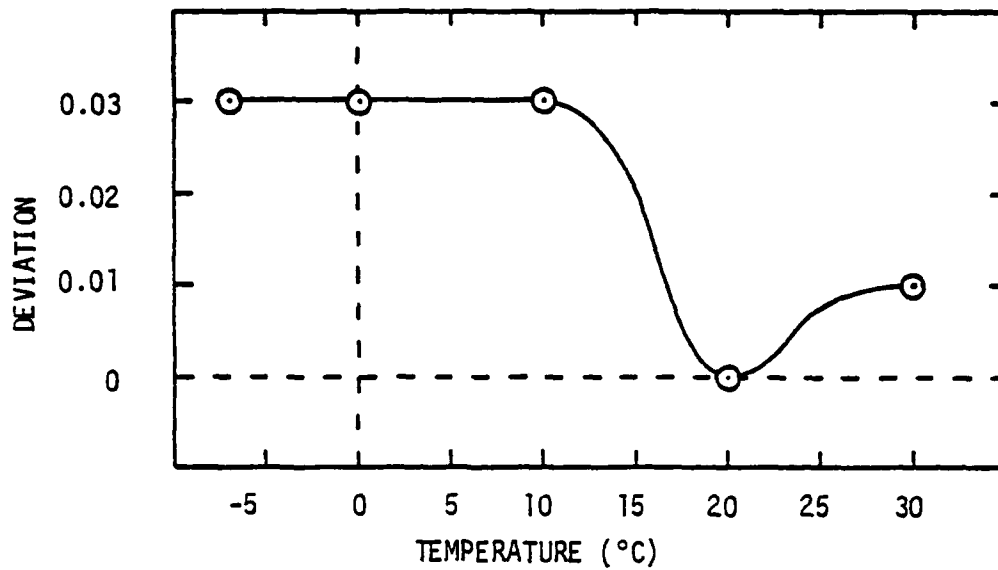

DEW POINT TEMPERATURE (THERMOMETER # 7K2146)

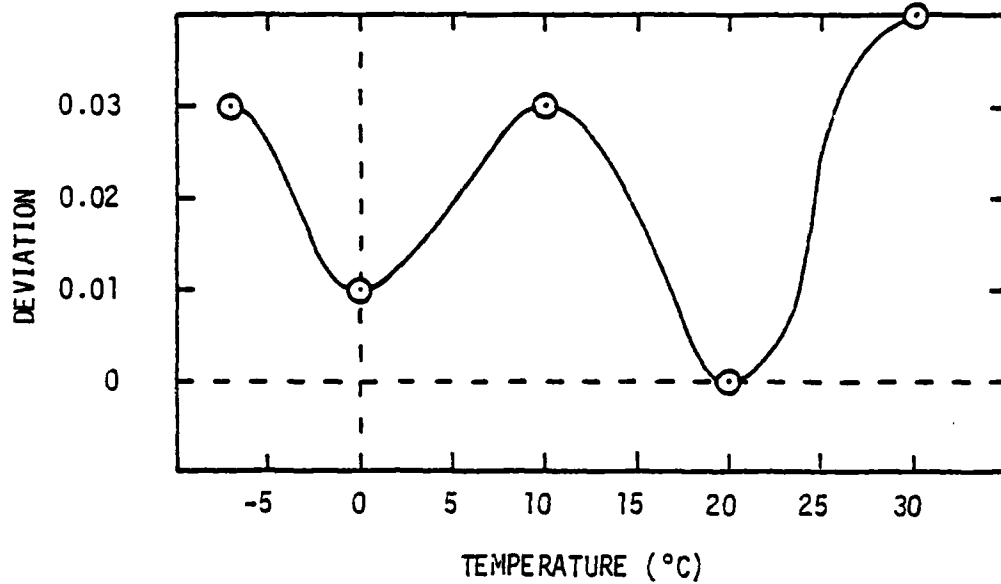

Fig. 4.17. Hygrometer Thermometers' Calibration Curves

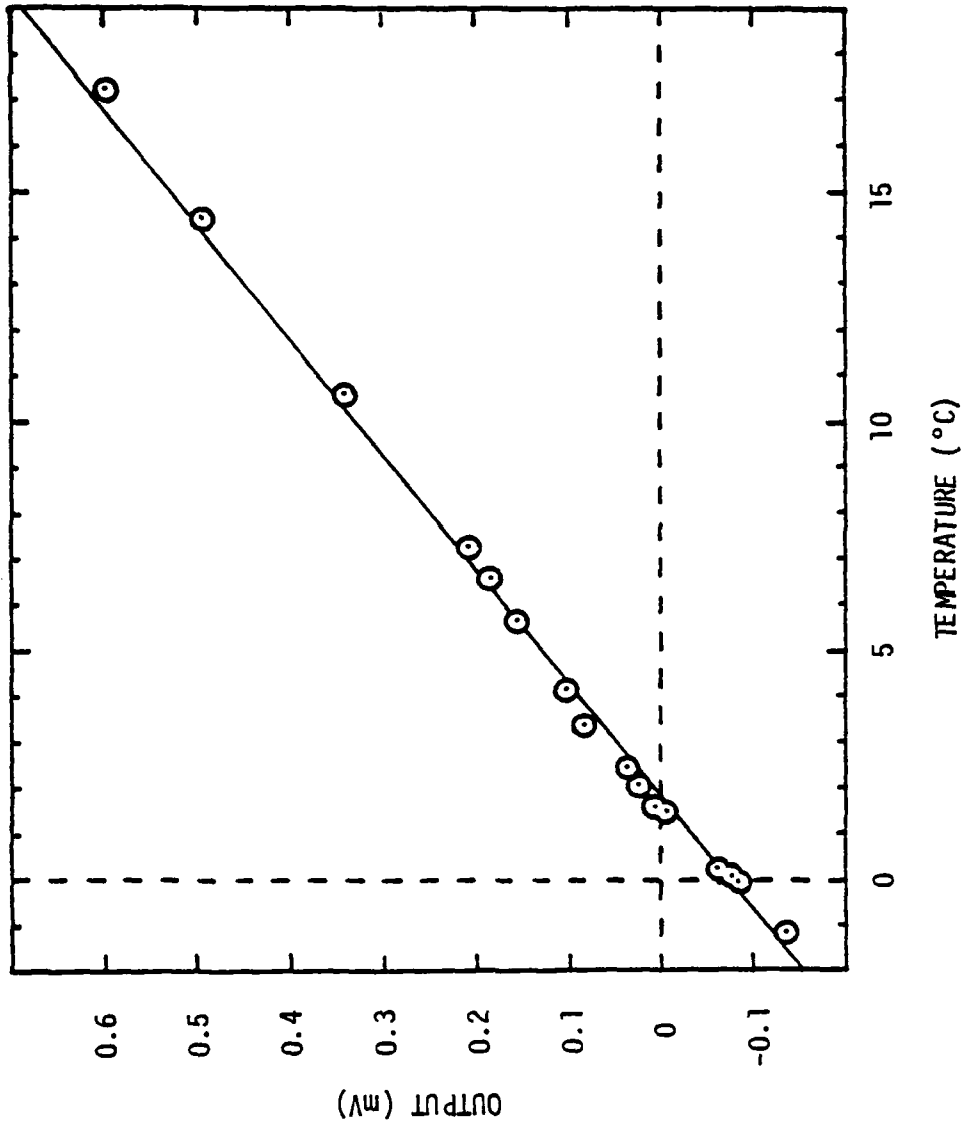

Fig. 4.18. Calibration Line for Settling Chamber Thermocouple

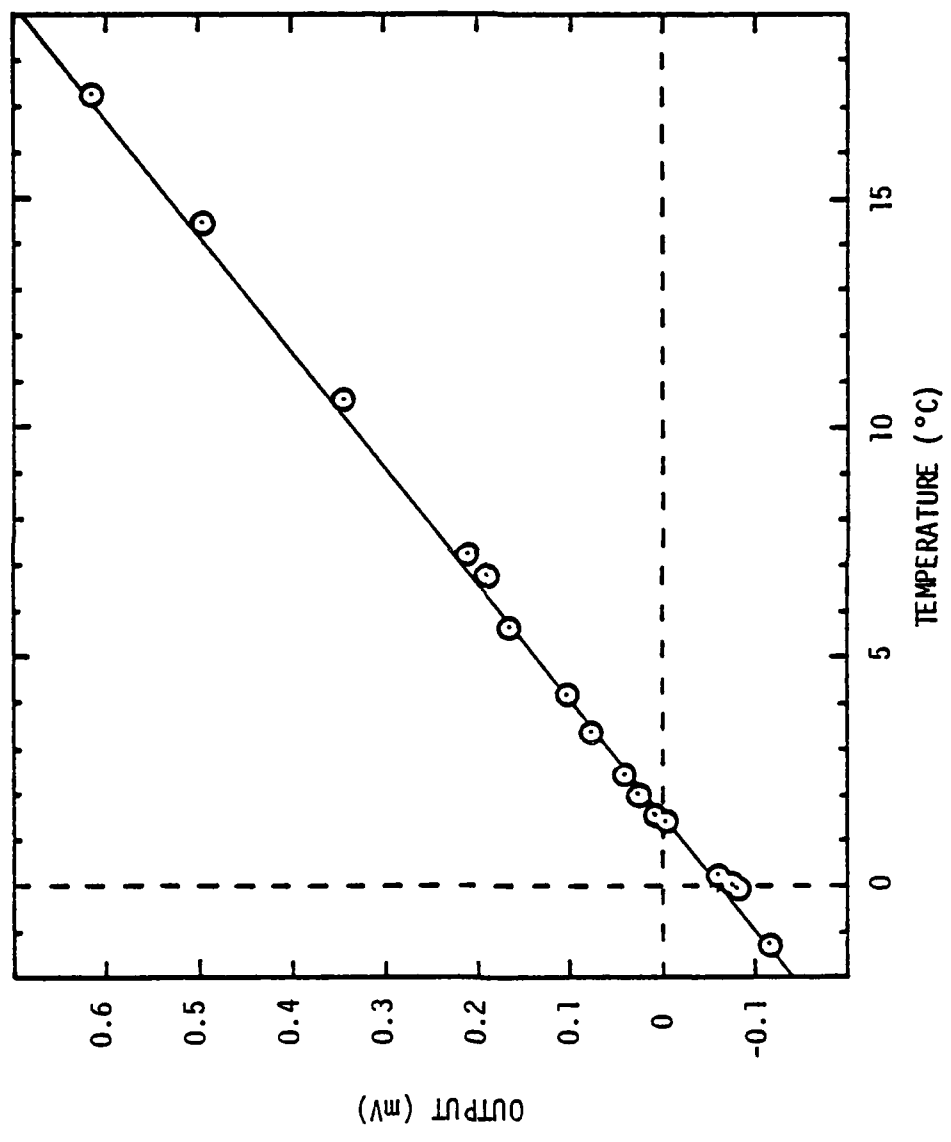

Fig. 4.19. Calibration Line for Outside Air Temperature Thermocouple

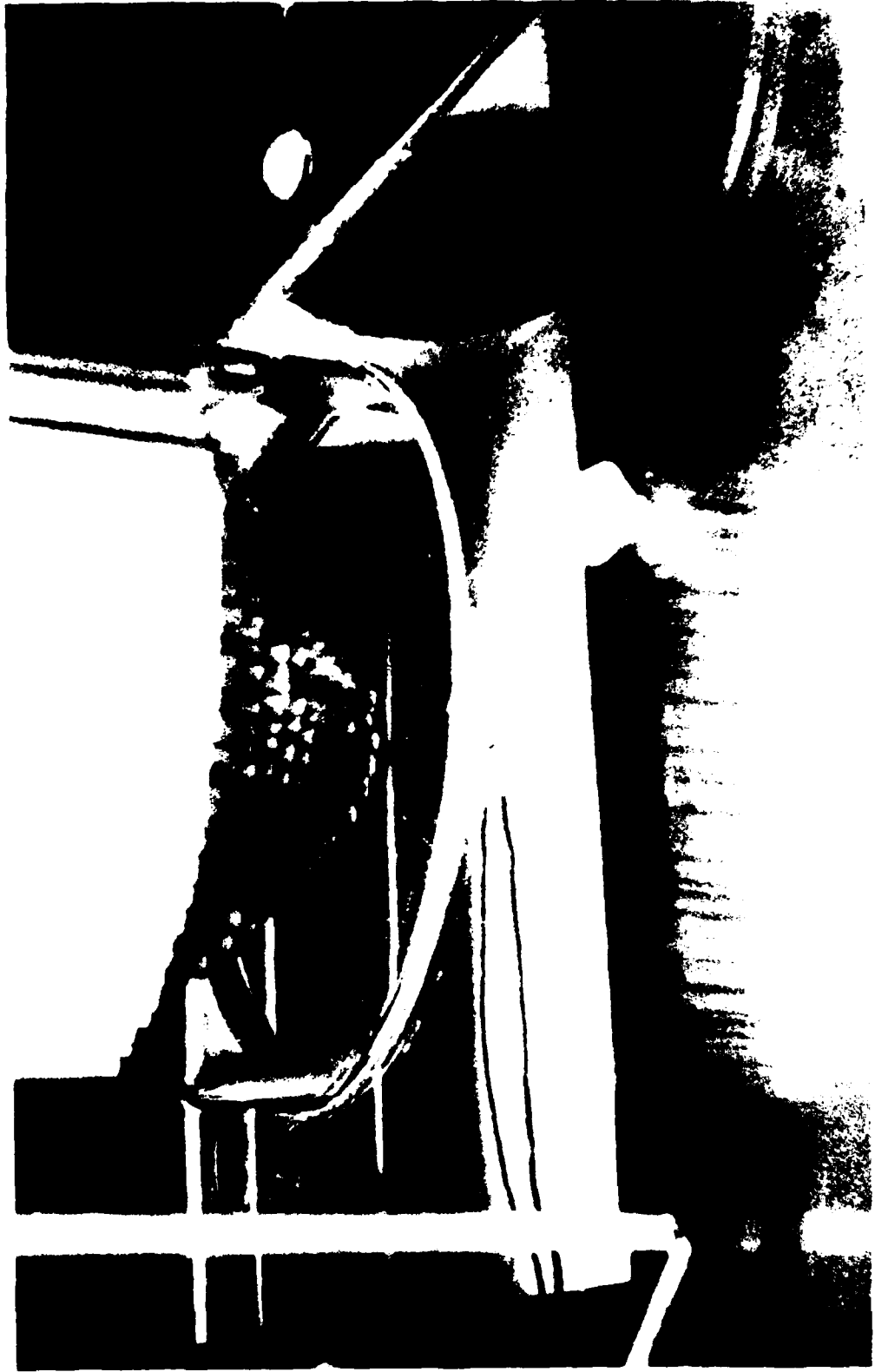

Fig. 4.20. Photograph of Settling Chamber Thermocouple

an object which could be used to simulate characteristics of a falling snowflake. This enabled testing of various parts of our suspension chamber at different phases of construction. Initially, 1/16 in (0.16 cm) diameter styrofoam balls were used. These were readily available as filling for bean bag chairs, but the effect of static electricity on these balls proved to be an overwhelming problem. The static electricity could be removed from the chamber by wiping it with a damp cloth, but almost immediately returned. Our next, and final, artificial snowflake was created by using a leather punch to form a 5 mm diameter aluminum disk, curved upward slightly at the edge. This was done by placing a sheet of heavy duty aluminum foil over a piece of chamois, used in washing an automobile, and punching out a disk. The disk weighed 1.9 mg and presented a profile more representative of the snowflake. This object was less affected by static electricity than the styrofoam balls and was also easily obtained. Later, during data collection, static electricity again became a problem. To combat it, we wiped the chamber thoroughly, inside and out, with "Cling Free", a product designed to remove static electricity from clothing during the drying cycle. This left a waxy film on the chamber, which was spread evenly with a damp towel and allowed to dry. Once dry, this coating was polished with a soft cloth until it became transparent. This procedure was very effective in removing the static electricity from our apparatus, thus enabling the artificial snowflake to be suspended. The first artificial snowflake used, along with the second and the equipment used to create it, is shown in Fig. 4.21.

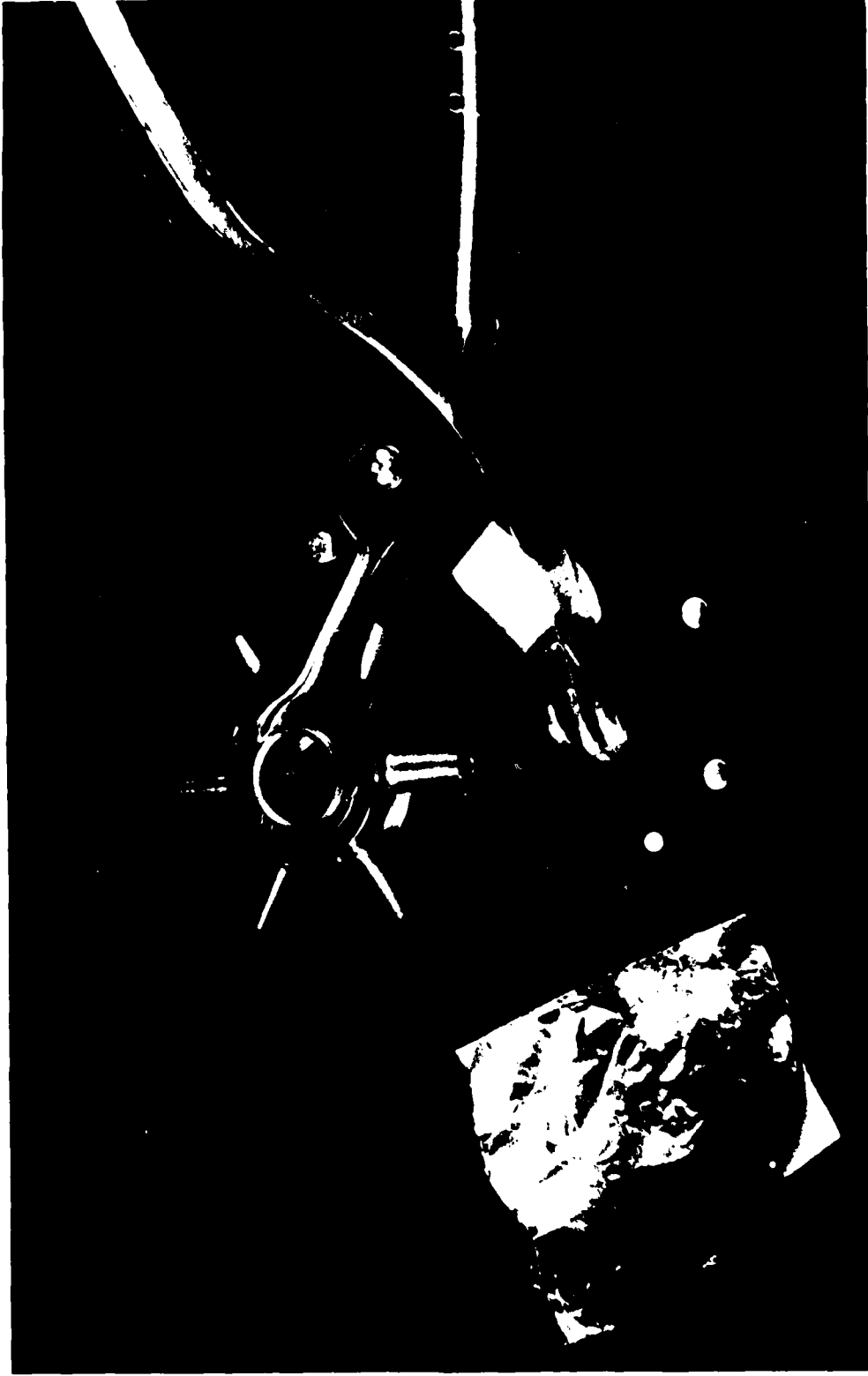

Fig. 4.21. Photograph of Artificial Snowflakes

Shelter

A suitable shelter was necessary to protect both our equipment and the operators from the environment, as the observations were taken during snowstorms, often at night, with temperatures well below 0°C, and lasted for several hours at a time. A shelter was made by building a wooden frame on the back of a 1968 Dodge 4-wheel drive Powerwagon. The framework was covered with two layers of plastic sheeting, and a layer of canvas, held in place by ropes. The equipment was mounted inside and access holes cut in the plastic. During experiments, the ropes were removed and the canvas folded back to expose the access holes (holes to allow the snowflake entrance to the chamber and an air intake for the conditioning system). It offered the further advantage of being mobile, which allowed travel up into the mountains when snow was not expected in the valley. Arrangement of the equipment is diagrammed in Fig. 4.22 and the shelter during an observation is shown in Fig. 4.23.

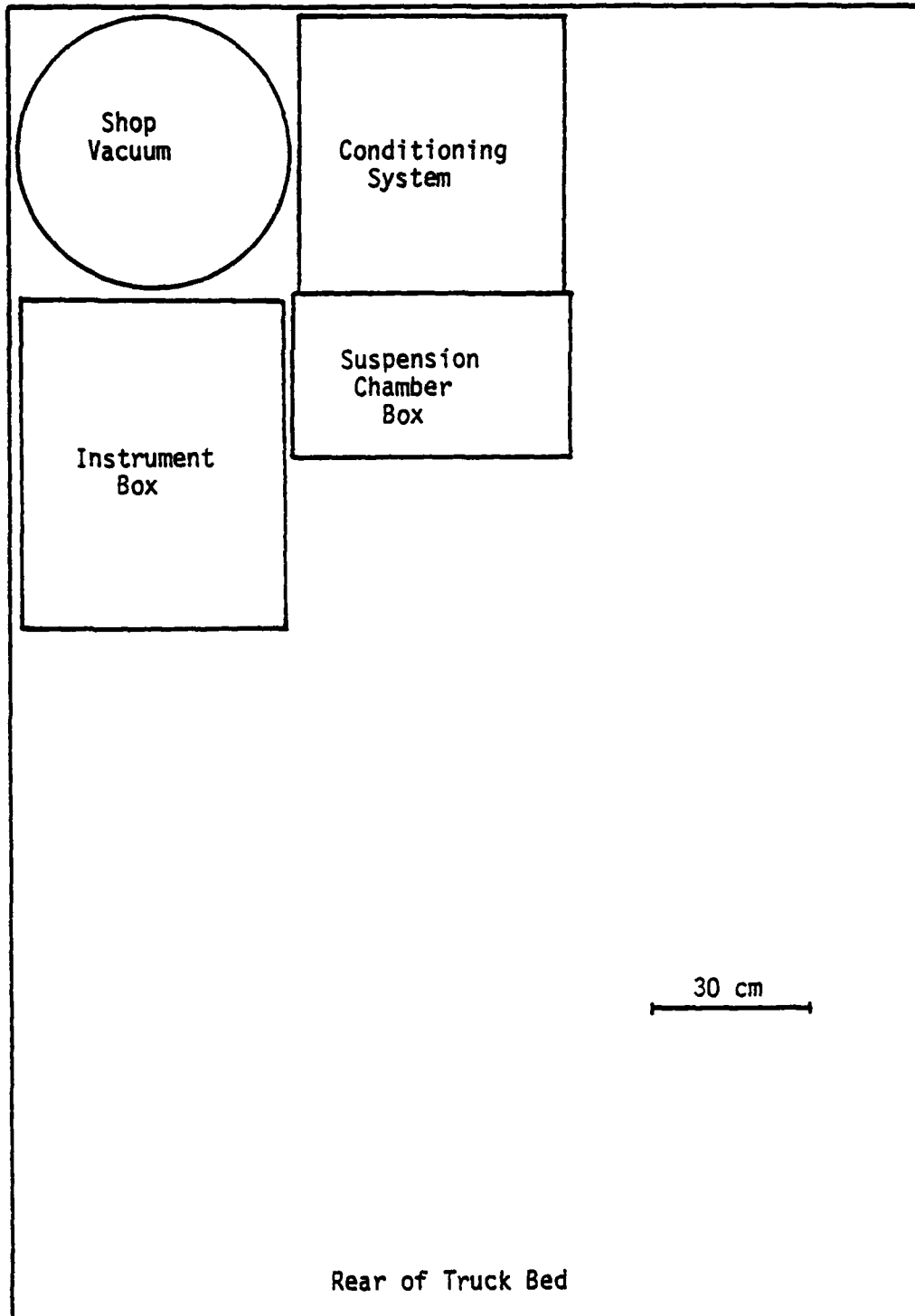

Fig. 4.22. Apparatus' Positioning in Shelter

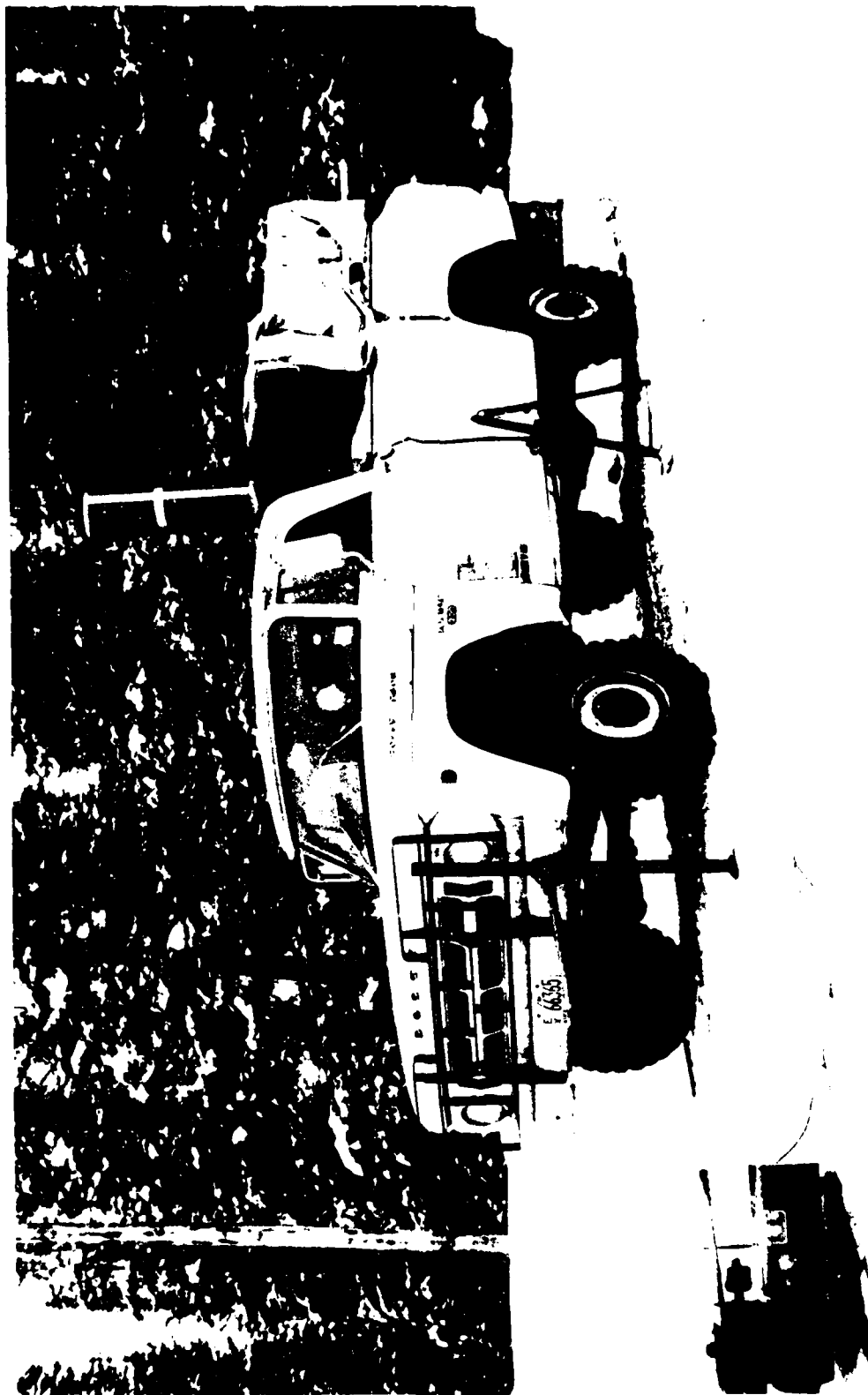

Fig. 4.23. Photograph of Apparatus' Shelter

Chapter 5

EXPERIMENTAL PROCEDURES

The most important part of any scientific study is that the results must be replicable by anyone who is properly trained and equipped. To insure this replicability, this chapter is divided into three sections (deploying, operations, and data analysis), in which the appropriate procedures are fully explained.

Deploying

Due to the limited snowfall during the first winter of this study, mobility became an important design feature. With the eventual placement of the experimental apparatus in the bed of a 4-wheel drive truck, travel to the mountains, where snowfall frequently occurred, was possible. The equipment used for this study is listed in Appendix C. As can be seen, the majority of the equipment is stored on the truck. When it was determined that snowfall would occur in the mountains and not at our location, the list in Appendix C was used to insure everything required to collect data was loaded. This process required only a few minutes. The use of a checklist throughout the data gathering process was indispensable as the absence of a critical component of the apparatus (film, recorder paper, ether, etc.) could cause that data gathering opportunity to be lost.

Operations

Setting Up

Upon arrival at the data gathering site, the truck was parked in the most level place available. If the suspension chamber was not in a true vertical position, the velocity profile (Fig. 3.6) was deformed and the stability of the snowflake affected accordingly. After unloading the equipment, a decision was made as to whether or not to use the opening controls and/or entrance tunnel. This was based on the snowfall intensity and experience. The equipment worked best when about four to ten snowflakes entered the chamber every minute. This gave ample opportunity to suspend and melt an individual snowflake. With higher snowflake concentrations, it became difficult to concentrate on a single flake. Also, the others could interfere with its suspension and eventually land on the chamber walls or screens where they left water deposits. These water deposits could disturb the air velocity profile or the photography, depending on their position. Once the equipment was unloaded, the work was divided between an outside and inside worker.

The duties of the outside worker are listed in Appendix D. An important initial step was the tunnel stability test using the artificial snowflake. Experience showed that if the artificial snowflake could not be suspended, the chance of suspending natural snowflakes was very small. This test was very useful in identifying potential problems. After the suspension test, the outside worker lowered the snowflake extractor, shown in Fig. 5.1, into the chamber, directly over the artificial snowflake. By applying suction to the short tube

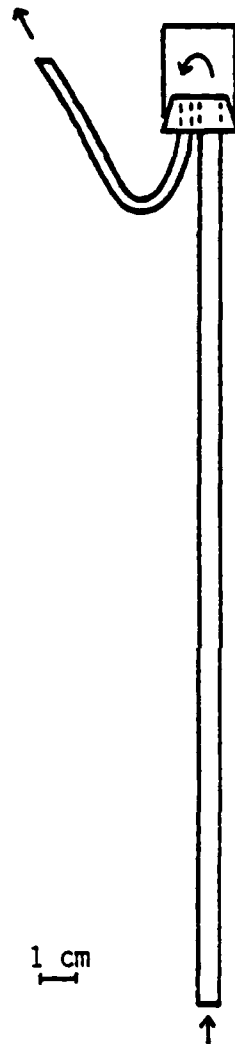

Fig. 5.1. Snowflake Extractor Device

(using the mouth), the snowflake was drawn up the long tube into the catch basin at the top. It could not pass through the short tube because of its size in relation to the tube.

The inside worker, like the outside, also has many tasks to complete, as shown in Appendix D. The two workers must communicate as they set up and confirm the proper operation of the equipment. In mounting the cameras, the camera with the 14 mm extension tube was placed on the top. These were properly aligned by sighting through them. With the top camera viewing from the edge of the screen up and the other from just below the first reference line up, the focal points of the cameras were in the center of the chamber, between the third and fourth reference lines. The cameras were then focused to their minimum distance. The film, Ilford HP5, was loaded evenly on both cameras. This facilitated analysis, as the negatives could be layed side by side and the top and side views would correspond. The first picture (referring to both top and bottom cameras) was of the number lowered into the chamber. This number referenced the film to other data recorded later. The recorder channels were zeroed as shown in Fig. 5.2. The checklists were reviewed just prior to data collection to confirm that all tasks had been completed.

Data Collection

As with setting up the apparatus, data collection was also a two-man job, with one person (hereafter called controller) operating the suspension chamber valve and the cable release/marker device and the other (the supporter) the opening to the insertion tube and taking

AD-A116 739

AIR FORCE INST OF TECH WRIGHT-PATTERSON AFB OH F/6 8/12
THE MELTING OF NATURAL SNOWFLAKES SUSPENDED IN A VERTICAL WIND --ETC(U)
JUN 82 S J DONOVAN
AFIT/NR-82-12T

NL

UNCLASSIFIED

2
2
616 739

1111
1111
1111

END
DATE
FILMED
8-82
DTIC

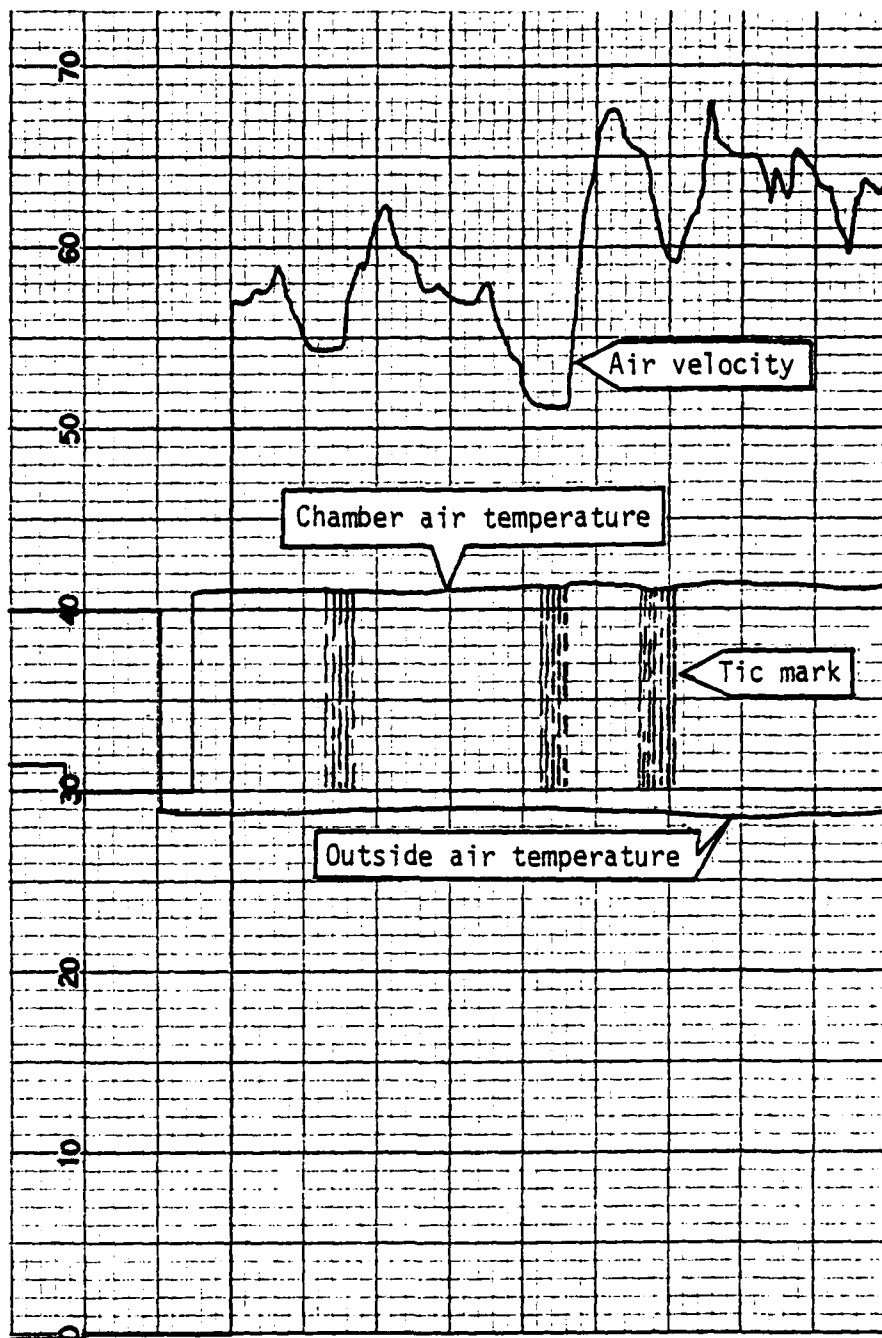

Fig. 5.2. Sample Recorder Strip

notes, data collection went smoothly.

Before data collection began, the controller measured the suspension chamber's ambient and dew point temperatures while the supporter wrote on the recorder strip the date, place, and time of observation, recorder chart speed, film roll number, and the values for the ambient and dew point temperatures. Data collection began with the supporter opening the entrance to the insertion tube. When a snowflake entered the suspension chamber, he immediately released the control cable, whereupon the spring loaded opening mechanism closed. Whereas before the air passing into the valve was being drawn both from the suspension chamber and from the outside, through the opening in the insertion tube, now it came solely from the suspension chamber. This gave an immediate velocity increase in the chamber, which was enough to cause most snowflakes to hesitate momentarily in their falling. During this hesitation, the controller increased the velocity and gained control of the snowflake's suspension. When the snowflake was under control, approximately two seconds after entering the chamber, the controller activated the camera release/marker device to record it. He also increased the airflow to keep the snowflake vertically stable as it melted and its fall velocity increased. This required practice to keep the snowflake in the optimum position for photographing. As the melting process progressed, both workers carefully observed the behavior of the snowflake. When the suspension was lost, the supporter recorded the information concerning that individual snowflake on the recorder strip. The number of pictures taken was also recorded. At this point, the supporter again opened the entrance to the insertion

tube and the process was repeated.

Throughout our data collection the temperature inside the chamber ranged from 1.8 to 3.9°C, without operating the heater, due to the outside air temperature, body heat, the electric heater, and other equipment inside the shelter. This was very convenient as these were some of the temperatures at which we desired to collect data. For other temperatures, the supporter must also control the heater through the on/off switch located on the front of the instrument box. By observing the temperature trace on the recorder and controlling the heater through its switch, any desired temperature could easily be maintained within $\pm 0.2^\circ\text{C}$ (0.01 mV).

Once the film ran out, data collection stopped temporarily while the roll was changed and the relative humidity inside the chamber was measured. Then the above procedure was repeated.

Occasionally it became necessary to stop operations to clean the suspension chamber. As snowflakes melted, they left water deposits that interfered with the photography and/or the airflow. Water drops on the wall and top screen of the chamber were removed by lowering a tissue through the opening in the insertion tube and blotting them up. Water in the honeycomb and screens were removed with compressed air. A nozzle was inserted into the settling chamber through an access hole and compressed air from a small compressor blew the water out of the honeycomb and screens. This water was then removed with the tissue. To remove any water still in the screens, the suction was turned to full power and heat applied through the settling chamber access hole with a hair dryer. The apparatus' heater was not used

because it heated up the entire equipment and its cooling time was longer than desired. The hair dryer applied heat directly to the area it was needed without heating up all the equipment. Using this procedure, the suspension chamber was quickly rid of any water deposits that could interfere with data collection.

Shutting Down

The procedures for repacking the equipment were also divided between an inside and outside worker. Using the checklist in Appendix D, this phase of operations took approximately 15 minutes.

Upon returning to the university, the supply levels were checked using Appendix C. If data collection was expected within the next 24 hours, the suspension chamber was also treated for static electricity as described in Chapter 4.

Data Analysis

The first step in analyzing the data was to develop the film. The recorder strip was used to determine sequence shots and these were marked on the edge of the negatives. (The rolls were left intact.) The negatives were then closely examined. If the film showed successive photographs of an individual flake, the recorder strip (Fig. 5.2) was closely analyzed for the relative humidity, suspension chamber temperature and air velocity corresponding to each frame in the sequence. The fall velocity of an individual snowflake was determined as explained in Appendix F. (Figure 5.3 shows a representative snowflake and the chamber reference lines.) The film was then re-examined in an enlarger and measurements were made for the snowflake's size and

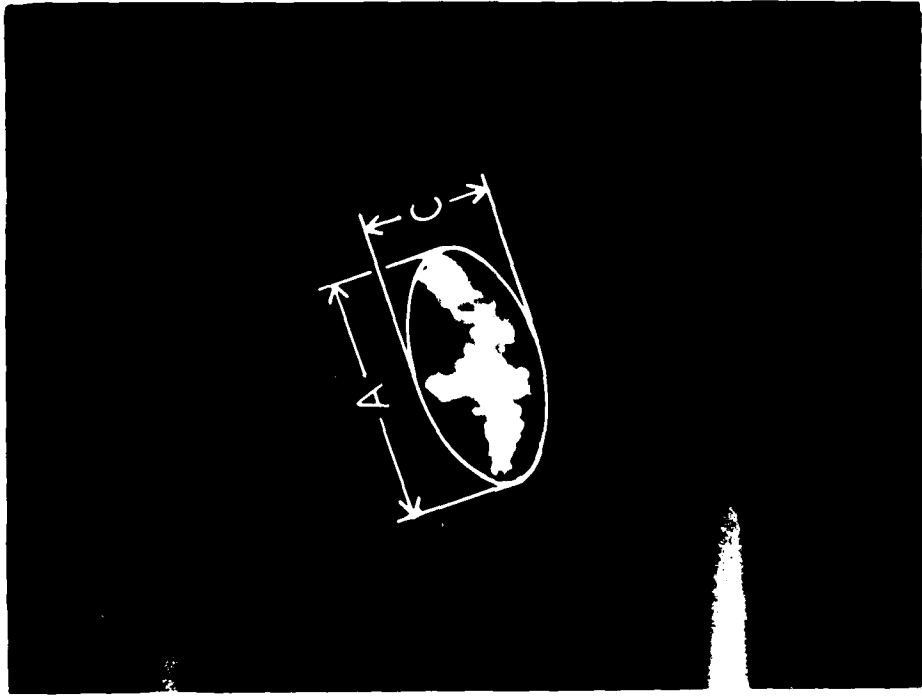

Fig. 5.4. Snowflake Size Approximation



Fig. 5.3. Suspended Snowflake and
Cramber Reference Lines

shape in each frame during the melting process through comparison with a previous photograph of a ruler. Figure 5.4 shows how a snowflake's size was approximated by an ellipsoid. The horizontal view was used in this approximation, with the top view serving as a check. If the top view showed the end of the snowflake to be towards the bottom camera, an estimation of its actual size was made. Also, a snowflake appearing out of focus on the bottom camera's picture would be measured as too large if closer than the center of the chamber and too small if back away from the center. The top view enabled us to determine which was the case. If a snowflake was not completely horizontal, with its widest side viewed by the bottom camera, a correction was made to the A value based on the top view.

The prototype photographic system also yielded suitable data for this study, although it was not used. With the camera shutter open as the snowflake fell, the stroboscopic illumination created a photograph such as is seen in Fig. 5.5. The distance between images was measured by comparison with a previous photograph of a ruler. With the stroboscope set at 100 flashes per second, the distance in centimeters was directly converted to a fall velocity in meters per second. Figure 5.6 shows the detail that was possible through enlargement of the negative.

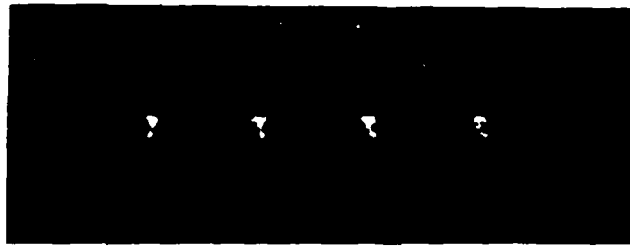

1.0 cm



0.5 cm

Fig. 5.5. Prototype Photographic System's Image

Fig. 5.6. Enlargement of Snowflake Image from Prototype Photographic System

Chapter 6

RESULTS AND DISCUSSION

While this study was not the first concerning the melting process of snowflakes, it was the first to do this under natural conditions. We sought to gain information on the size and shape of snowflakes, their mass and the fall velocity during the melting process. These observations were to be made while a natural snowflake, having not yet impacted with the ground or any other object, was suspended in a column of air, completely independent of any artificial support (wires, nets, etc.). This required the design, construction and operation of a vertical wind tunnel, small enough to be transported to the field (to enable data collection if snowfall was not occurring at our location). In this chapter, the performance of the equipment constructed to satisfy the study's requirements and the results obtained are discussed.

Apparatus' Performance

The performance of a piece of equipment in a laboratory versus actual operating conditions may be completely different. Field conditions place new demands on the equipment, many of which cannot be foreseen. Such was our case.

The problem of static electricity surfaced early in our equipment construction. This was initially solved by wiping the chamber with a damp cloth, then by replacing the artificial snowflake with one which

was not as susceptible to static electricity. During our early experiments, we learned that small snow crystals are also greatly affected by static electricity. This had to be completely removed from the chamber, which we did using the procedure discussed in Chapter 4. We discovered that this treatment of the chamber was not permanent. Therefore, we treated the equipment for static electricity prior to every storm and checked for its presence at the beginning of each data collection period.

The principle of a thermocouple's operation is rather simple, but is dependent upon an ice bath of 0°C . Normally, crushed ice will melt enough to give this condition. Under our operating conditions, though, the crushed ice was found not to melt, thereby giving an ice bath temperature of less than 0°C , which caused the thermocouple to give a high reading. This was corrected by flushing the crushed ice with water until an ice bath of 0°C was obtained.

The position of a snowflake in the suspension chamber was very important. Unless centered after entering the upper portion of the chamber, they hit the wall. In the upper regions of the chamber, the air velocity profile was flattened and the snowflake could impact with the wall before the velocity profile was sharp enough to direct it to the center. When centered, the velocity profile moved it away from the wall as it fell into the observing area and was suspended. Snow crystals could be suspended almost anywhere in the chamber, depending upon their size. Very small ones, approximately one millimeter or less in diameter and appearing only as a sparkle of light, could even be suspended on the crest of the velocity profile.

We found that our apparatus was not suitable for all types of frozen particles. Graupel proved to be too dense to suspend and snow which was mostly melted was unusable. With a surface temperature of approximately 7°C, the snow falling, along with small water droplets, was very dense and "sticky". Once in the chamber, if not properly positioned, it landed on the wall or screen and quickly melted. This left a water deposit which interfered with the chamber airflow and/or our visibility. Best results were obtained by waiting until later in the storm when the surface temperature dropped and the snowflakes were not melting. Also, moderate snowfall was required to receive a significant number of snowflakes into the chamber. The entrance, 2.54 cm in diameter, could have been enlarged, but would have created a much larger velocity change when closed quickly. A slow closing of the entrance proved to be undesirable (the flake was further into the melting process before accurate observations could be obtained and proper velocity control for suspension was too difficult).

Large snowflakes, greater than ten millimeters in diameter, were seldom observed in the chamber, due to several reasons. The concentration of these size flakes during a storm is much less than that of smaller flakes. Also, the entrance to the chamber was only 2.54 cm in diameter. Often, while waiting for an object to enter the chamber, we observed a shower of small crystals. This occurred when a snowflake struck the side of the entrance opening. Once in the entrance tube, the positioning of the snowflake became a factor. All these combined to limit the number of snowflakes observed.

One of the biggest problems during this study was the frailty of

our apparatus. While the equipment was packed as carefully as possible, transport to the field sometimes weakened a small wire or loosened a connection. The cold environment placed additional stresses on the equipment. When the apparatus functioned properly, it did all that it was designed to do, but the suspension of a snowflake/crystal was a very delicate operation and could easily be disturbed.

Qualitative Observations

The data collection for this study was performed during the 1981-82 winter season. During this time, over 2700 frozen particles were observed during their melting process. These were almost completely dendritic and complex crystals. From these observations, several surprising patterns surfaced.

Usually only in small crystals, from 1-3 mm in diameter, we observed that the crystals rotated around their vertical axes. We called this "helicoptering". The size of smaller crystals (and their appearance as a sparkle of light) prevented us from observing this, but larger ones did not helicopter. The larger flat, symmetrical, dendritic crystals, less than 0.3 mm thick, occasionally shifted about their vertical axes, but no helicoptering was observed. This helicoptering movement did not affect our ability to suspend a crystal. Helicoptering was not observed in snowflakes.

The vertical stability of a suspended snowflake/crystal was dependent upon its size and shape. The small crystals, less than one millimeter in diameter, were the easiest to suspend. These weren't dependent upon the velocity profile to hold them. They could be suspended anywhere in the chamber for one or two seconds, during which

time they melted. Snowflakes/crystals became increasingly unstable with size, due to the way they melted.

The most surprising observation during this study was the way snowflakes/crystals melted. It is currently proposed that snowflakes have an ice skeleton which maintains its original shape during most of the melting process (Matsuo and Sasyo, 1981a). Figure 6.1 shows a top and corresponding side view of a snowflake melting in our chamber. This ice skeleton can easily be seen. Matsuo and Sasyo postulate that this ice skeleton collapses to a water drop because of surface tension. Knight (1979) stated that as water drops grow at favorable sites within an aggregate, its ice skeleton is exposed and these connecting arms then melt faster than the ice within the drops. When these connections finally melt, a single large particle becomes several smaller ones. He noted this phenomenon existed in some cases, but could claim no practical importance for it. We found that as these snowflakes/crystals melted, this disruption process, as Knight called it, was of predominant importance. The melting characteristics of snowflakes/crystals could be divided into three categories.

In crystals from 1-3 mm in diameter, the helicoptering characteristic became dominant during the melting process. As time progressed, the crystal began circling around the center of the chamber, rather than helicoptering. With each pass, the circle became wider and wider, until, just fractions of a second before melting, the crystal impacted with the chamber wall. We called this the "death spiral". Only a change in the crystal's aerodynamic configuration, possibly disruption, could cause this. This death spiral was observed only

Top View

Side View



Elapsed Time



2.0 s



3.5 s



5.0 s

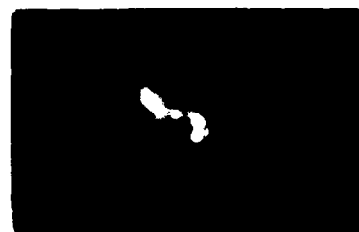

6.5 s

← 0.5 cm →

Snowflake disrupted 1.5 seconds later

Fig. 6.1. Snowflake Melting Sequence

at the end of the melting process, and only with this size crystal.

Crystals less than 1 mm in diameter appeared as a sparkle of light. As previously mentioned, they were easily suspended until the last fractions of a second of their crystal form. Then, instead of falling down toward the bottom of the chamber, these crystals were observed to take a violent jump. Current melting theory suggests these would be transformed into spheres, which now, having a smaller cross-sectional area to mass ratio, would fall faster. In our observations, this downward fall, which should be a uniform increase in velocity, was the exception. These small crystals would be as likely to jump sideways as straight up. A crystal suspended several centimeters from the chamber wall would often just jump over onto the wall and appear instantly as a water droplet. Static electricity as the cause of this was ruled out because of our test with the artificial snowflake (which was very sensitive to static electricity) and the violent nature of the crystal's movement, and only at the end of its melting process. A change in the crystal's aerodynamic structure, caused by disruption, could cause this movement. The loss of a small portion of a crystal could cause the remainder to be swept into the wall by the airstream. Total disruption could also cause the pieces of the crystal to be swept straight up and out of the measurement area.

Disruption also offers the most reasonable explanation for the snowflake's behavior in the final seconds of its melting process. The snowflake shown in Fig. 6.1 was easily suspended with a gradual increase in the chamber's airflow throughout the pictures shown.

However, just after the fourth photograph, it broke up and fell to the bottom of the chamber. This was the case with all the snowflakes we suspended. They were easily suspended, as they decreased in size by melting, up to a certain point (twenty seconds being the longest under the temperature and relative humidity ranges of this study), whereupon they broke into several pieces, with the larger pieces falling to the bottom of the chamber and the smaller ones being swept up and out of the observation section. This occurred as if there were a small explosion in the snowflake. The velocity of the larger drops was such that when their wings (small droplets connected by the ice skeleton) were lost, they fell out of the measuring section of the chamber (from about 2-12 cm above the top screen) before the operator could react to increase the airflow and catch the drop. This phenomenon was difficult to record without a movie camera.

Large, flat, symmetrical, dendritic crystals fell flat and were not affected by this disruption phenomenon. They melted slowly from the outer edges in towards the middle as they drifted into the wall. No breakoff of a portion of the crystal was observed. This action of drifting into the wall after being stably suspended indicates that the velocity profile suitable for a snowflake/crystal is not appropriate for a water droplet. Further information concerning the melting process of snow crystals can be obtained from the thesis work done by Savage (1982).

Quantitative Observations

The previously mentioned problems associated with the suspension of a snowflake reduced the number of cases observed to 42. These fall

into the following groups:

<u>Relative Humidity</u>	<u>Temperature</u>	<u>Number of cases</u>
90%	3°C	1
	4°C	16
100%	2°C	4
	3°C	15
	4°C	5

The snowflakes were initially identified visually. From these observations, particles larger than 2.5 and 1.0 mm (A and C dimensions) were considered snowflakes and included in this study. The number of observed snowflakes precludes any firm conclusions from being drawn, but an analysis of this data suggests some areas where further research would be of interest.

In analyzing the data, several assumptions were made. As shown in Fig. 5.4, an enveloping ellipsoid was used to represent the size of a snowflake. No attempt was made to compensate for the amount of the ellipsoid filled by the outer dimensions of the snowflake. Therefore, two snowflakes of the same measured size could have completely different masses. The snowflakes were all assumed to have been in the chamber environment for two seconds by the time the first photograph was taken. This value was based on what we felt to be the average time for a flake to enter the chamber and the operator gain control of its vertical stability. Finally, the melting time had to be estimated due to the disruption phenomenon. This phenomenon, along with the apparent inability of our velocity profile to suspend a water droplet, precluded the measurement of mass, but velocity, size and shape changes during the melting process were recorded and will now

be discussed.

Velocity Change

Figure 6.2 shows the fall velocity change with time of six area categories of snowflakes. These areas represent maximum horizontal cross-sectional areas, perpendicular to the direction of fall. All conditions observed are included in this graph. With the exception of the 15-20 and 25-30 mm area groups, flakes with larger areas seemed to fall faster than those with smaller areas. A comparison of the fall velocities of equal size area groups under the same temperature conditions but different relative humidities suggests some interesting information. Figure 6.3 shows fall velocities for conditions of 90% relative humidity and temperature of 4°C. Figure 6.4 gives fall velocities for the same temperature but with a relative humidity of 100%. The fall velocity for the same size snowflake appears to be higher in the 100% relative humidity environment than in the 90%. This may be explained by noting that in an environment of 90% relative humidity, evaporation occurs along with melting, so the mass decreases. In the saturated environment, melting occurs, but there is no evaporation, so the mass remains constant. Under the latter condition, as the horizontal cross-sectional area decreases due to melting, the velocity increases because the mass is constant. This same observation is made from a comparison of fall velocities for like groups under the same relative humidity conditions but different temperatures (Figs. 6.5 and 6.6). The velocity appears to be greater in the higher temperature condition (3°C) because the drop is melting faster, thus its cross-sectional area is smaller. These indications may be a results only

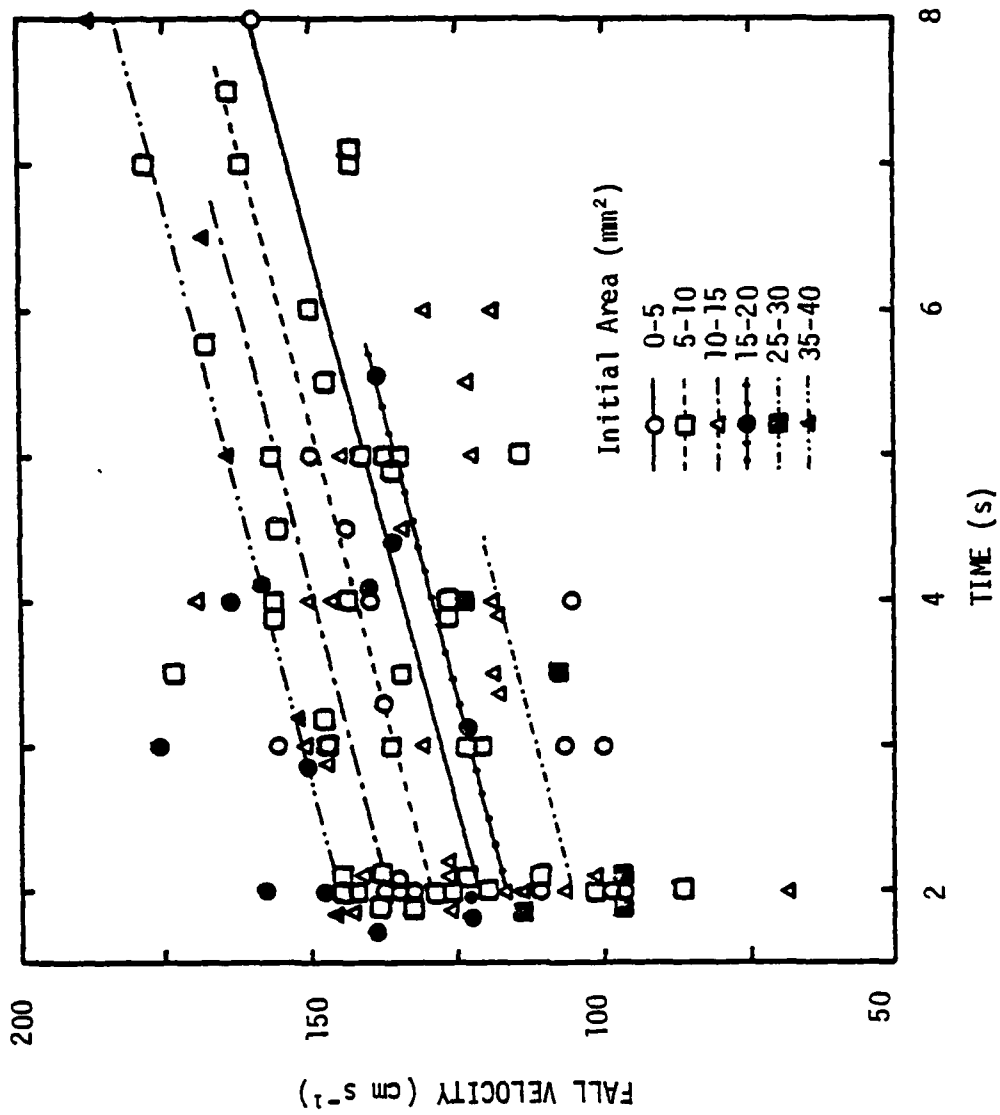

Fig. 6.2. Fall Velocity vs Time

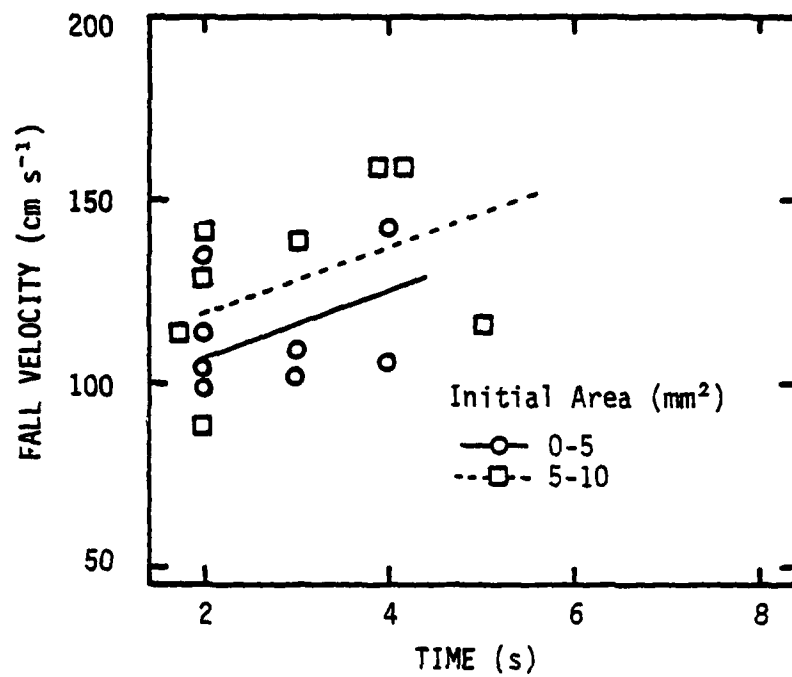

Fig. 6.3. Fall Velocity vs Time (at 4 °C, 90% RH)

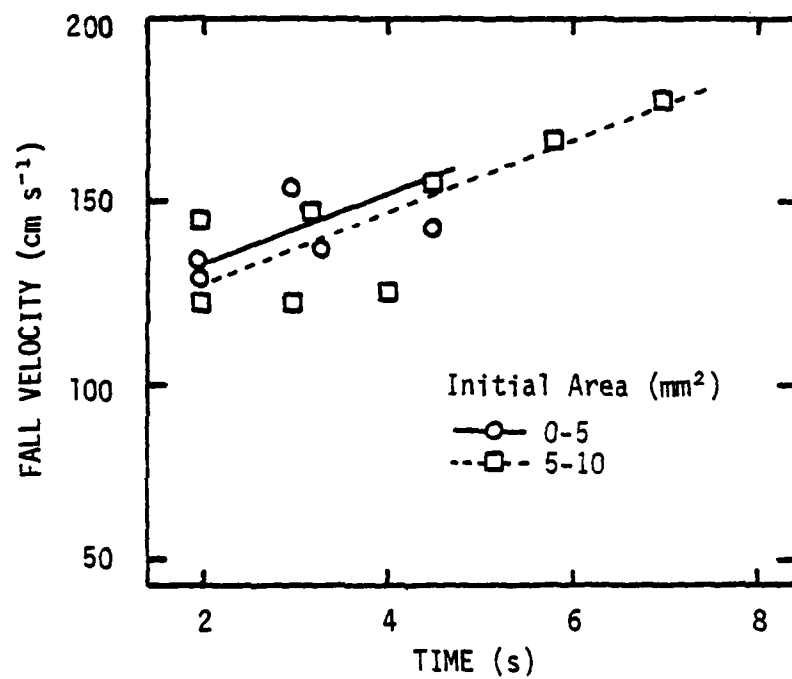

Fig. 6.4. Fall Velocity vs Time (at 4 °C, 100% RH)

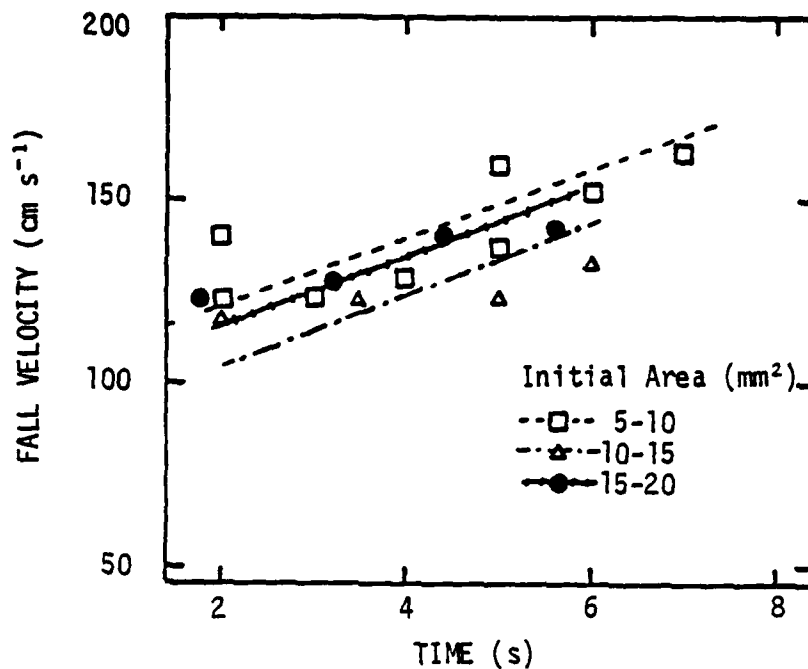

Fig. 6.5. Fall Velocity vs Time (at 2°C, 100% RH)

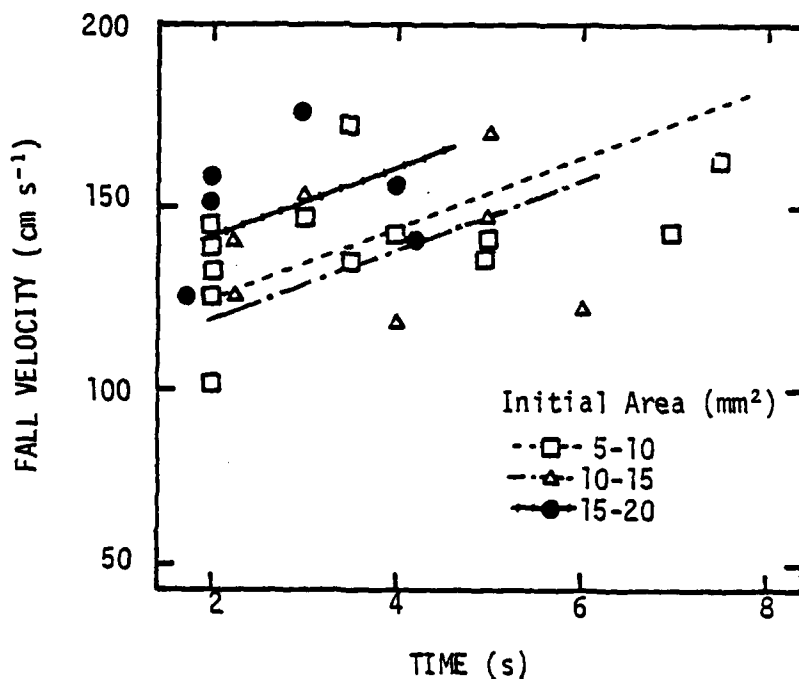

Fig. 6.6. Fall Velocity vs Time (at 3°C, 100% RH)

of our limited data base or artificially high environmental temperature, but in any case, this area should be further studied.

Shape Change

Our observations of shape change with time support the widely accepted theory of snowflakes melting into spherical water droplets. Figure 6.7 shows the areas of various size groups to be decreasing towards final values (the areas of the water droplets). This, and the following graphs (Figs. 6.8 to 6.11) may lead one to an erroneous conclusion when considered alone. Observations proved that snowflakes melted at such a rate that their suspension was controllable, until they disrupted. This disruption size was not predictable. Because this disruption occurred so quickly, a photograph could not be obtained, thus no values could be analyzed. This is why these graphs alone cannot accurately show what actually happened in nature. A comparison of Figs. 6.8 and 6.11 seems to show that the area of a snowflake decreases faster under 90% relative humidity than in the saturated environment. This is in agreement with the observations of Matsuo and Sasyo (1981c).

Melting Rates

A comparison of melting time versus the initial diameter of the snowflakes observed in our studies (Fig. 6.12) yields some surprising information. Current theory of snowflake melting (Matsuo and Sasyo, 1981a) predicts a curve which is concave upwards (by treating the snowflake as a solid object), while our data shows a convex curve. The melting time increases with size, but there is no appreciable time

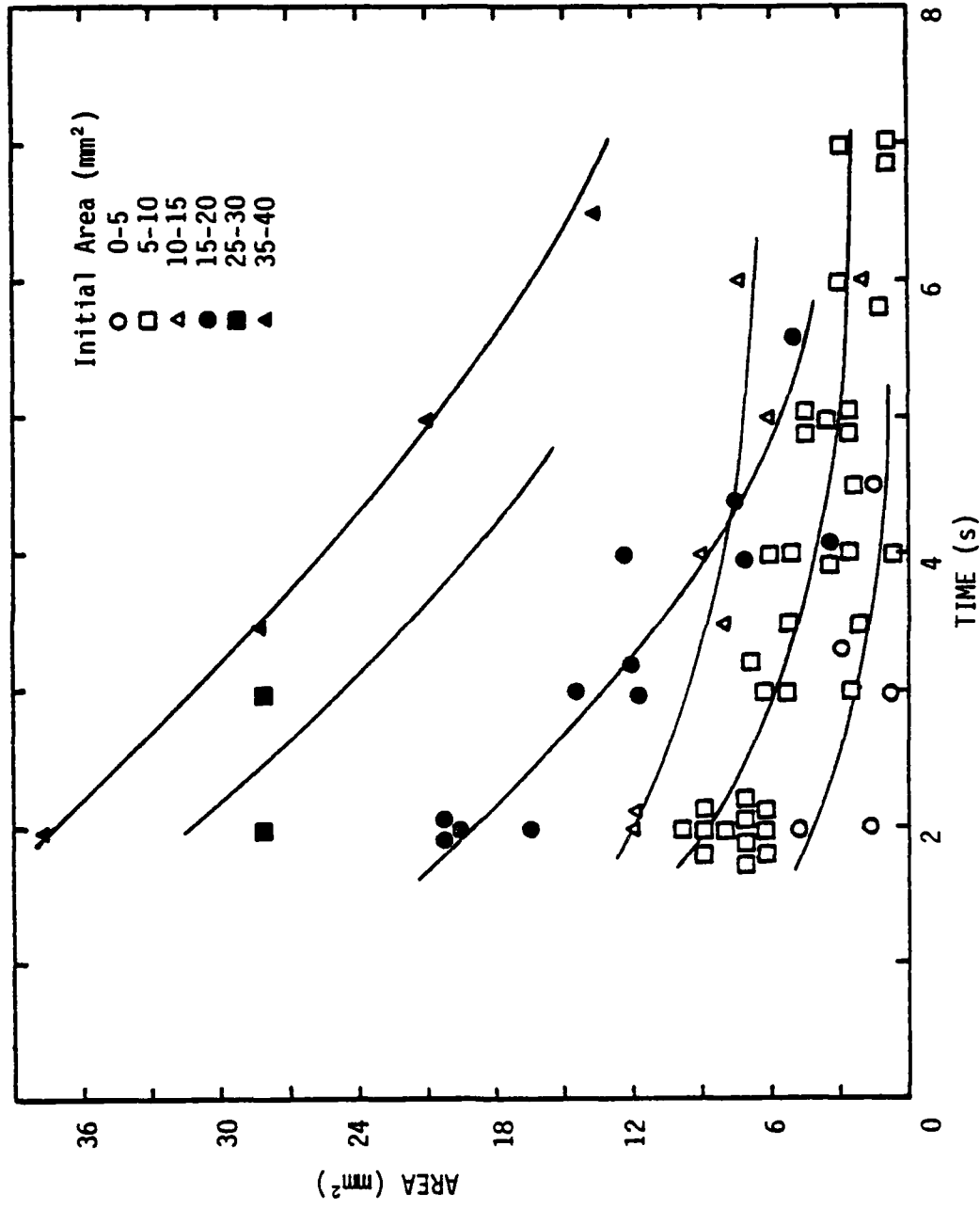

Fig. 6.7. Horizontal Cross-Sectional Area vs Time

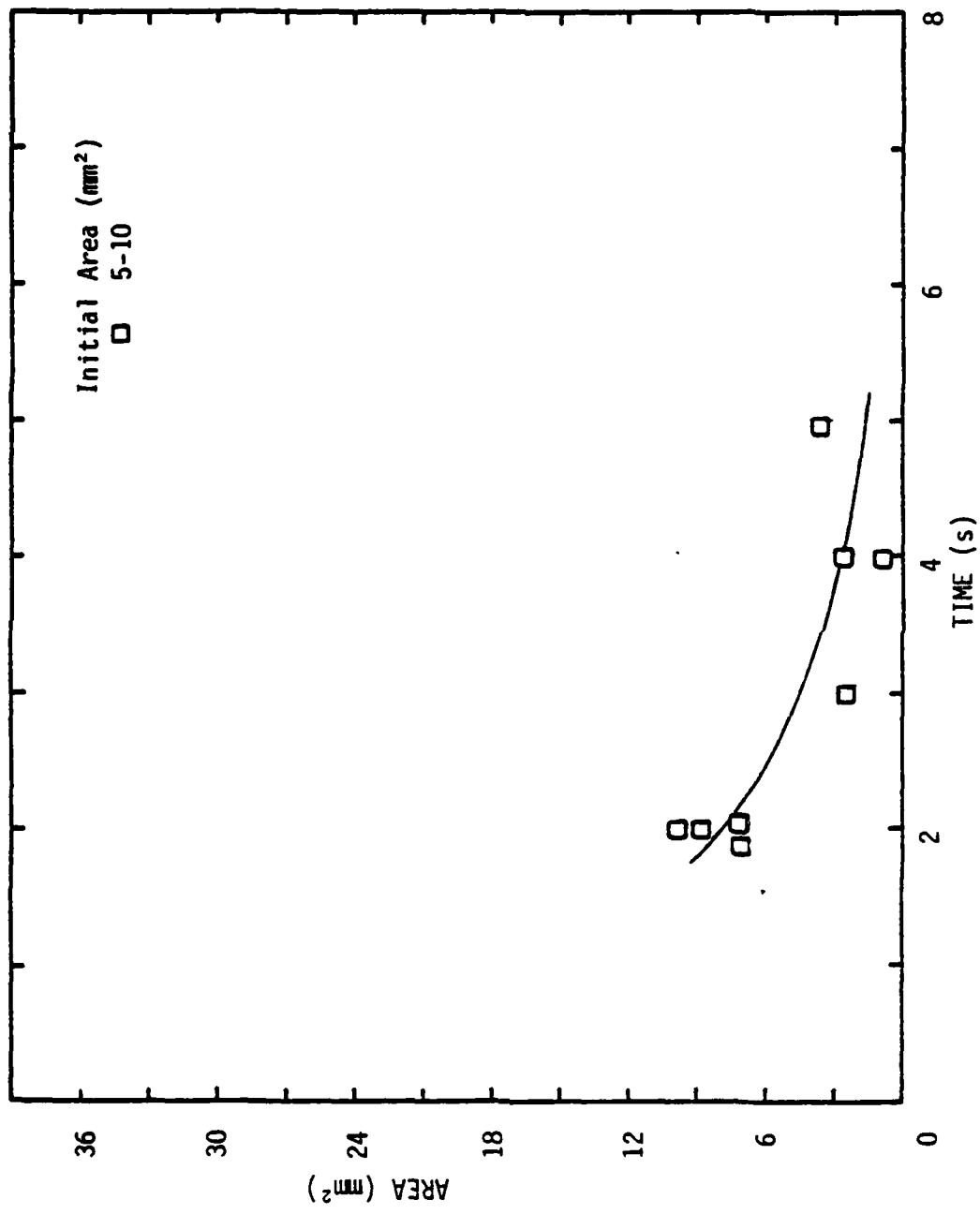

Fig. 6.8. Horizontal Cross-Sectional Area vs Time (at 4°C, 90% RH)

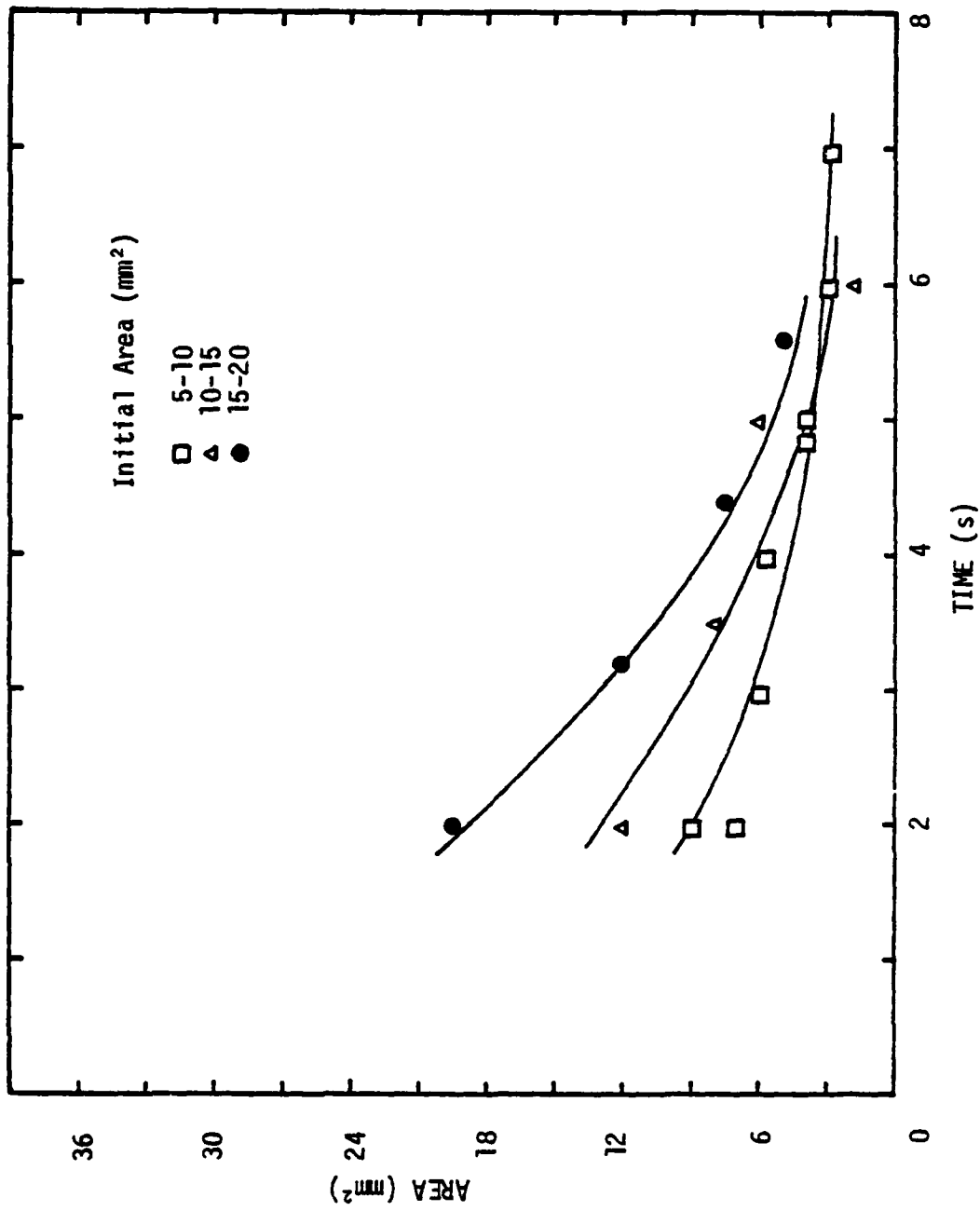

Fig. 6.9. Horizontal Cross-Sectional Area vs Time (at 2°C, 100% RH)

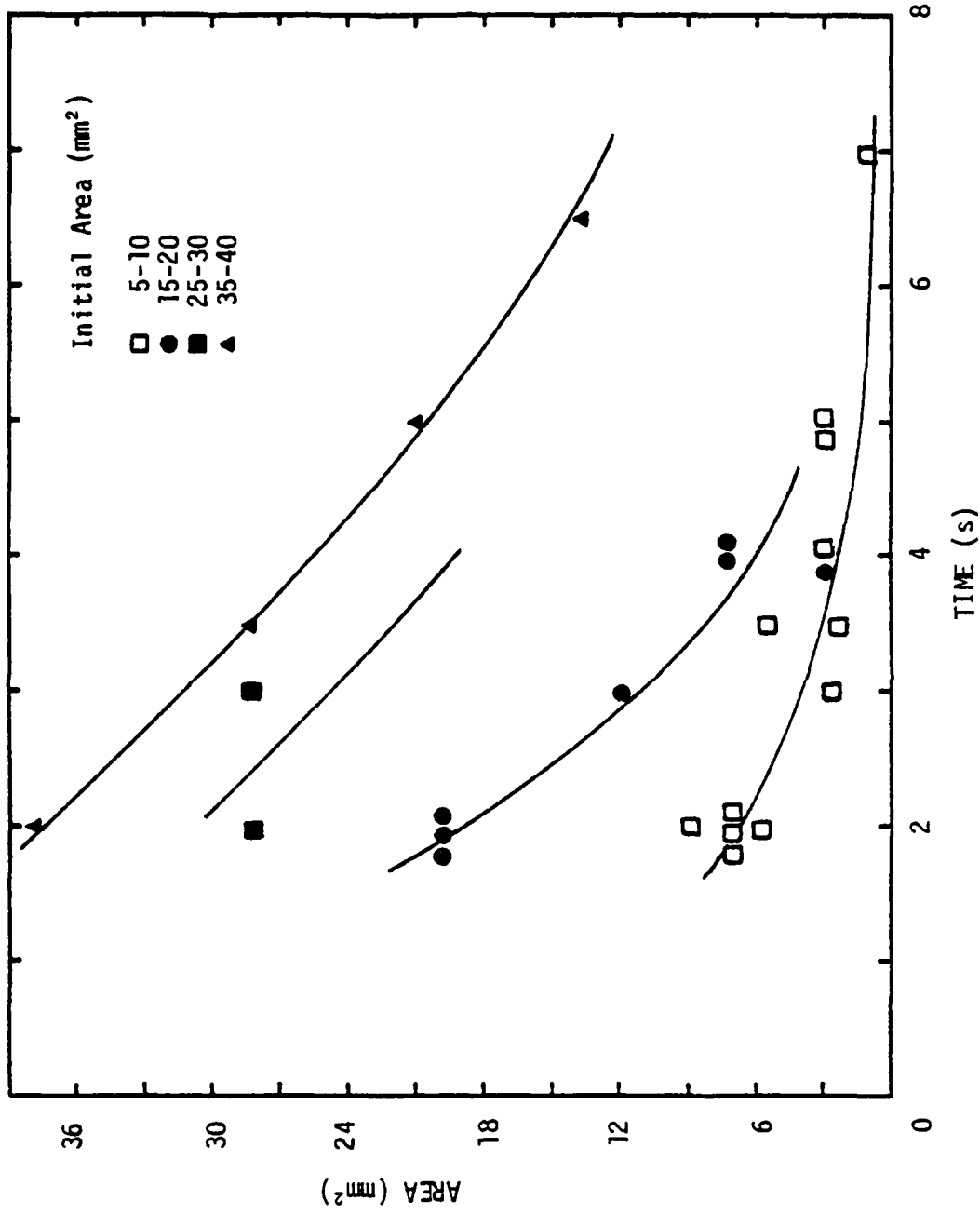

Fig. 6.10. Horizontal Cross-Sectional Area vs Time (at 3°C, 100% RH)

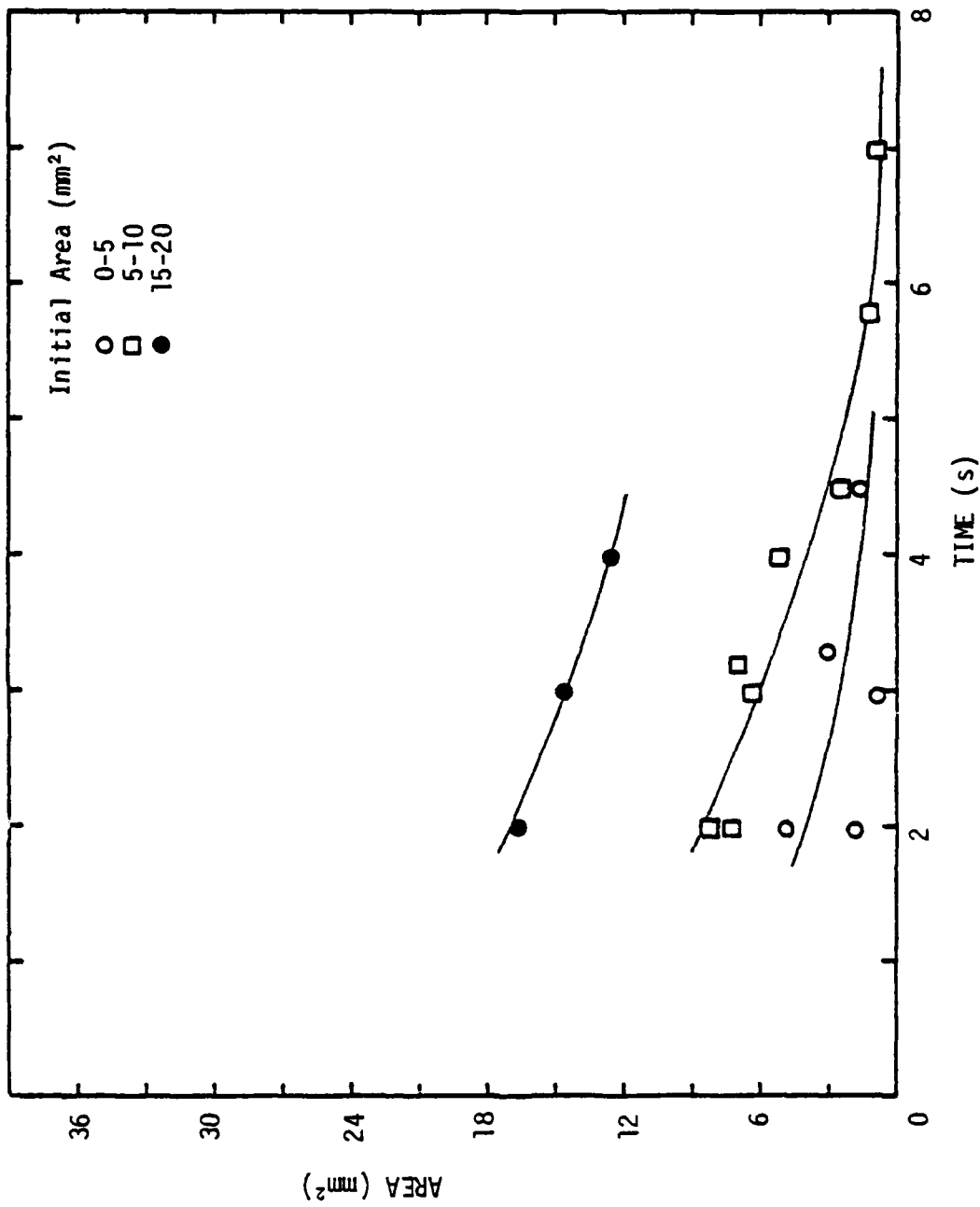

Fig. 6.11. Horizontal Cross-Sectional Area vs Time (at 4°C, 100% RH)

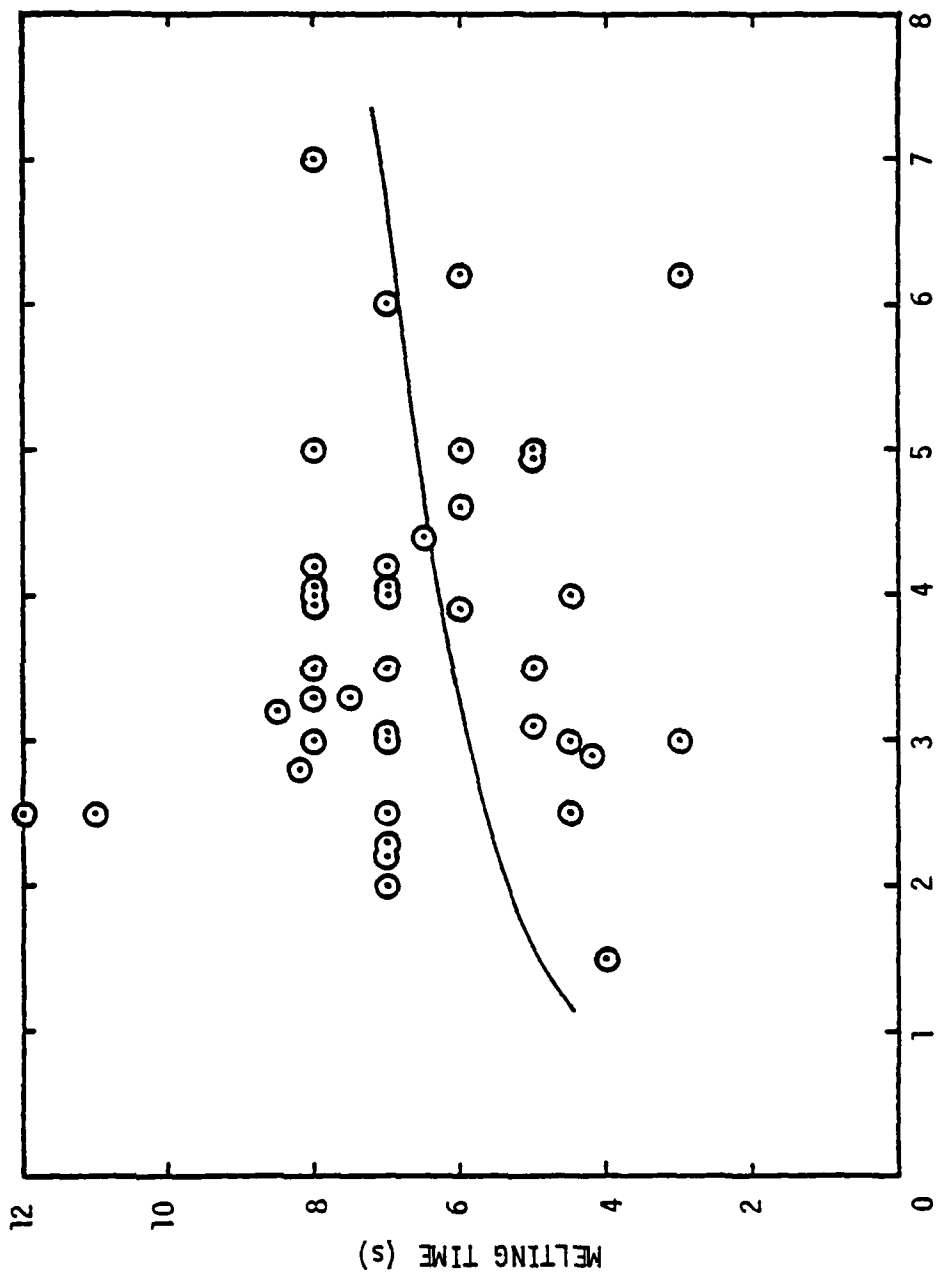

Fig. 6.12. Melting Time vs Initial Diameter

difference between sizes. This may be because snowflakes are of a porous structure, not solid, thus allowing the air to pass through them. This air passing through the body of the snowflake as it falls makes the heat transfer distance nearly as small as that for a small ice crystal. Thus the crystals which make up the snowflake can melt somewhat independent of each other. The larger the snowflake, the larger the ice skeleton, which would explain the slightly longer melting time. A comparison of melting times versus initial areas for an environment of 90% relative humidity versus 100% relative humidity has been done by Matsuo and Sasyo (1981b). Our data (Figs. 6.13 and 6.14) is not sufficient to conclude that snowflakes of equal area decrease more slowly in a subsaturated environment than in a saturated environment.

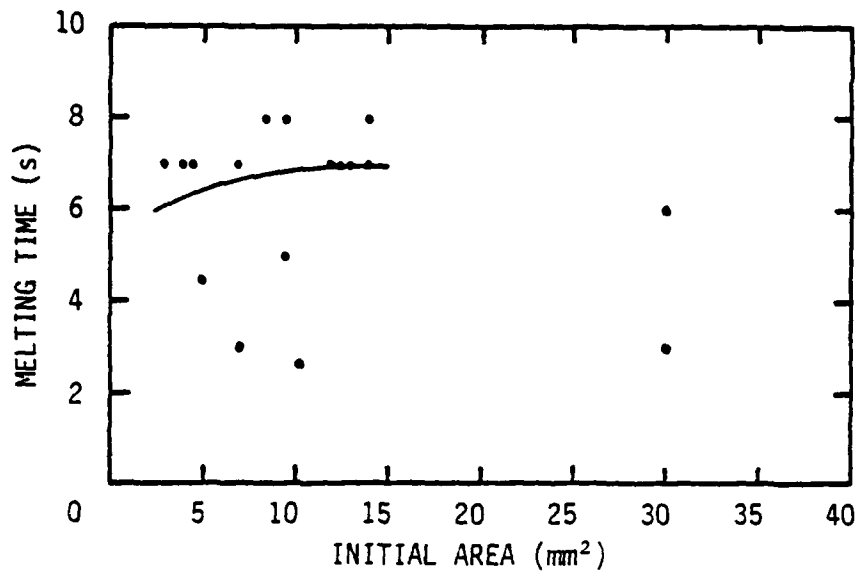

Fig. 6.13. Melting Time vs Initial Horizontal Cross-Sectional Area (90% RH)

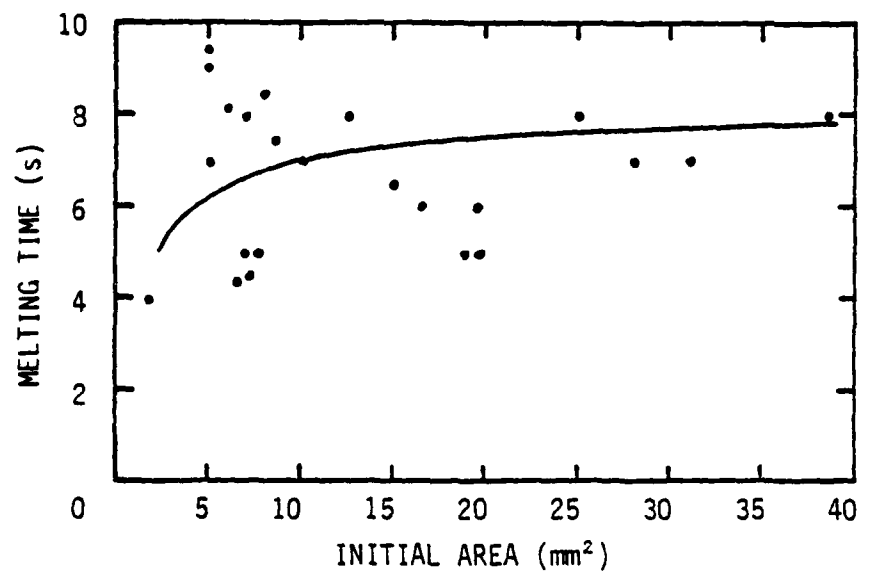

Fig. 6.14. Melting Time vs Initial Horizontal Cross-Sectional Area (100% RH)

Chapter 7

CONCLUSIONS AND RECOMMENDATIONS

Past studies of the melting processes of snowflakes/crystals have had several limitations on them. In almost all cases, the flakes/crystals were studied either under suspension on some type of support or after catching them first and then depositing them into the equipment. While these studies have yielded some limited information, our study sought to more closely represent the atmospheric conditions by suspending the natural snowflake/crystal freely in an airstream. The main features of the apparatus developed and employed in our study, the results of the observations, and possible future areas of research using the equipment are as follows.

Apparatus' Features

The main features of the apparatus developed for this study are:

1. A new system was designed to allow control of the temperature and relative humidity of the air passing through the suspension chamber. This allows observations to be made under wide ranges of temperature and relative humidity.
2. To obtain the appropriate air velocity profile critical to suspend a snowflake, a system of screens and a honeycomb was developed. A divergent design was employed for the chamber, wherein the velocity decrease towards the top helps the snowflake to seek its own level of suspension throughout the

melting process.

3. A special valve was developed to control the air velocity in the suspension chamber while maintaining a constant air-flow rate through the conditioning chamber, thus keeping the air in the chamber at a constant temperature and relative humidity.
4. A device which allowed the simultaneous activation of two cameras, while recording a mark on the flatbed recorder, was designed and constructed.
5. To enable the object to enter the chamber safely through a zone of high turbulence, a special insertion device was constructed. This device also slowed the fall of the snowflake in the chamber while the operator gained control of its vertical stability.
6. A unique method of completely removing the static electricity from the apparatus was devised. Static electricity was found to be a controlling factor in the suspension of snowflakes/crystals.
7. The entire apparatus was constructed in sections to enable transport to areas of snowfall. This removed data collection somewhat from its dependence upon the whims of nature.

While our apparatus performed almost all that it was designed to do, use of the equipment throughout this study yielded the following suggestions for improvement:

1. The camera activation/marker device should be connected to the entrance control of the chamber. This would allow the

operator to have complete control over the actions of the snowflake. The equipment might be further modified to allow for one-man operation.

2. A movie camera would allow the documentation of the disruption phenomenon. Occurring at the end of the melting process, this was difficult to capture with still cameras.
3. A taller suspension chamber would give the operator more reaction time in the case of fast falling particles.
4. An improved shelter for the apparatus would allow more room for the operators and access to the equipment. A window would enable the operators to monitor outside conditions more easily.
5. The conditioning system should be excluded from the shelter. The heat from the equipment and the operators hampered operation of the equipment near 0°C.

Main Findings

The unique capabilities of our apparatus enabled us to observe the melting processes of snowflakes/crystals under closely simulated atmospheric conditions. The main findings in our observations are as follows.

1. The observed melting time of snowflakes increased with size, but rather gently. The increase was far slower than that predicted by current theory.
2. Snow crystal disruption, in which a crystal melts not into a spherical water droplet, but into several pieces, was confirmed. This phenomenon was observed to be a dominant

factor in the melting of snowflakes/crystals, rather than an interesting occurrence as previously thought.

3. The vertical stability of a suspended snowflake appeared to be dependent upon its size and shape. Small crystals, less than 1 mm in diameter, were the most stable.
4. Helicoptering, or the rotation of a crystal around its vertical axis, was observed in crystals 1-3 mm in diameter.
5. Crystals 1-3 mm in diameter went into a death spiral during the last portion of their melting process.
6. Crystals less than 1 mm in diameter jumped violently at the end of their melting process. This jump was upwards or to the side, but seldom downwards.
7. Large, flat, symmetrical dendritic crystals (less than 0.3 mm thick) fell flat and were very stable in the chamber air-stream. They melted as the current theory predicted, from the outside inwards. There was no disruption of these type crystals.
8. The snowflake's shape changed gradually while the melting proceeded. The shape change appeared faster in the subsaturated environment. A final shape was never observed, however, due to the disruption phenomenon.

Recommendations for Future Research

The equipment developed for this study is unique. The melting of snowflakes has never been studied in the present manner. Because of the startling observations, this work should be duplicated and the disruption phenomenon properly documented. The melting processes of

snowflakes and snow crystals should be studied under other combinations of temperature and relative humidity. With this new apparatus, further studies of the melting layer in the atmosphere and the effect of size and shape changes on RADAR and LIDAR images are only a few of the possible areas of future research.

Appendix A

POWER REQUIREMENT OF HEATER

To determine the power requirement of the heater, it was first necessary to calculate the airflow rate (FR).

$$FR = \pi r^2 v$$

where v (air velocity) was taken to be 1.5 m s^{-1} and r (radius) was taken at its minimum, 5.08 cm . This gives

$$FR = 12160.98 \text{ cm}^3 \text{ s}^{-1} .$$

The air density (ρ) was calculated from

$$\rho = 0.273 \rho_0 P T^{-1} ,$$

where $\rho_0 = 1.275 \text{ mg cm}^{-3}$ is the density of air at pressure $P = 1000 \text{ mb}$ and temperature $T = 273^\circ\text{K}$. Since 850 mb and 273°K were estimates of the conditions we would be operating under, we have

$$\rho = 1.084 \text{ mg cm}^{-3} .$$

Thus the airflow rate can be expressed

$$FR = 13.2 \text{ g s}^{-1} .$$

Since the heat (dq) required to warm 1 g of air by $dT^\circ\text{K}$ is

$$dq = c_p dT ,$$

where c_p is the specific heat of air at constant pressure and the desired maximum heating capability is about 15°C , the power (P) to heat the air flow is

$$P = \rho (FR) c_p dT .$$

Now, knowing that $c_p = 1.005 \text{ J g}^{-1} \text{ }^\circ\text{K}^{-1}$, we have

$$P = 199 \text{ J s}^{-1} .$$

This heat has to be supplied by electricity and

$$P = E^2 R^{-1} ,$$

where E is the voltage and R is the resistance.

Using 115 volts and the above power requirement, we have

$$R = E^2 P^{-1} = 6.66 \Omega .$$

So, theoretically, to give our heater the capability of a 15°C temperature rise, we needed a resistance of 6.66 ohms.

Using 30 gauge alumel wire, with a resistance of 9.94 ohms per meter, we strung 4.2 meters of this wire in our heater. This gave a calculated resistance of 65.9 ohms. In actual testing, this heater gave only a 3.4°C temperature rise in our apparatus. This was due to heat loss from convection over the heater and absorption by the metal walls of the conditioning system. Besides the solutions mentioned in Chapter 4, we reduced the resistance by adding another 8.4 meters of wire in parallel. With these modifications, we achieved a more than 25°C warming capability, much more than was required.

Appendix B

ANEMOMETER/RECORDER ACCURACY

To determine the accuracy of the anemometer, three tests were conducted and the voltage outputs at the indicated velocities were averaged, compared to the values supplied by Kurz Instruments Inc. and an error percentage calculated.

Table 2 shows the results of the voltage outputs of the three tests conducted.

Because of the placement of the anemometer probe in our apparatus, the recorded velocities were five meters per second and higher. The measurement error of the anemometer/recorder was calculated by adding the differences obtained and dividing them by the standard values for the speeds 5-30 meters per second. This gave an error of 1.18%, as shown below.

$$\frac{0.083 + 0.088 + 0.055 + 0.033 + 0.043 + 0.023}{2.81 + 3 + 3.535 + 4.01 + 4.405 + 4.725 + 5} = 0.0118$$

Table 2
Comparison of Anemometer with Standard*

Velocity (m s ⁻¹)	Output Voltages (V)				Difference
	Test			Standard*	
	1	2	3		
0	-0.030	0.000	-0.010	0.000	0.013
0.5	0.925	0.970	0.980	1.020	0.062
1	1.325	1.340	1.350	1.395	0.057
1.5	1.590	1.625	1.620	1.660	0.048
5	2.725	2.725	2.730	2.810	0.083
6	2.890	2.925	2.920	3.000	0.088
10	3.450	3.470	3.490	3.525	0.055
15	3.970	3.980	3.980	4.010	0.033
20	4.350	4.375	4.360	4.405	0.043
25	4.675	4.720	4.710	4.725	0.023
30	5.000	5.000	5.000	5.000	0.000

*supplied by Kurz Instruments, Inc.

APPENDIX C

EQUIPMENT CHECKLIST

Instrument Box

- *Thermos insert with crushed ice
- Recorder pens and paper
- Calibration graphs
 - OAT--outside air temperature
 - Inside air temperature
- Anemometer

Photographic Apparatus

- *Cameras
 - *Spare batteries
 - *Winders
 - *Batteries
 - Set on SINGLE
 - Cable release/recorder marker
- *Film
 - *14 mm extension tube on top, 7 mm on bottom
- Flash
 - AC adapter
 - Cord to camera

Tool Kit

- Screwdrivers
 - Common--short and long handled
 - Phillips
- Wrenches
 - 1/2"
 - 7/16"
- Wire cutters
- Pliers
- Tape
 - Duct
 - Masking
- Flashlights
 - *Batteries
 - Bulbs
- Extension cord
- Vehicle jacks

Miscellaneous Kit
Paper towels
Paper
Tissues
Pens, pencils
Clipboard
Work light
Bulbs

Hygrometer
Ether
Measuring bottle

Entrance Tunnel
Opening Controls

Outside Air Thermocouple Shelter

Generator
Gasoline
Oil
Funnel
Alcohol (methanol)

*Water Jug
*Water
Spout
Spare drainage hose clamp

Electric Heater

Step Stool

Artificial Snowflake Extractor
Artificial snowflakes

Vacuum
Variac

Vehicle
Gasoline
Oil

*Indicates items not stored on the truck.

The following items are permanently fastened in the truck bed.

Conditioning System

Heater cover

Air entrance tube

Suspension Chamber Box

Suspension chamber

Screens

Honeycomb

Settling chamber

Insertion tube

Valve

Background light

Light shield

DC power supply

Appendix D

OPERATIONS CHECKLISTS

Setting Up

Park truck in a level place

Position generator

Unload outside air thermocouple shelter, hygrometer, and entrance tunnel (decide if opening controls/chamber are to be used)

Outside worker

Uncoil extension cord

Attach clamp to conditioning system drainage hose (clamp is attached to extension cord)

Check oil and gasoline levels in generator

Start generator

Attach extension cord

Level truck using jacks

Fold canvas back, cleaning snow off roof in process

Install outside air thermocouple shelter, position probe

Position opening controls/entrance tunnel (if used)

Insert and extract artificial snowflake to test chamber stability

Lower number for film marking into chamber

Check for leaks in conditioning system

Outside air RH measurement

Add ether

(Clean as necessary)

Inside worker

Put water in conditioning system

Turn on water pump

Clear passage for wet/dry/mixed operations

Turn on vacuum (variac set to 30%)

Remove cover from instrument box (electrical connections/anemometer connection should already be in place, check)

Position outside air thermocouple

Install ice bath for thermocouples--insure 0°C

Install pens in recorder

Attach inside air temp probe/marker to instrument box

Install camera system

14 mm extension tube on top

Attach cameras, checking:

ASA setting (1600)

AUTO position

Aperture setting to F16
 Focused
 Winder settings to SINGLE
 Attach cable release/marker device
 Load film--use take-up reel to insure film is properly
 installed
 Check batteries
 Cameras set to AUTO mode
 Attach flash
 Turned on--set to automatic operation
 Charging properly
 Take picture of film identification number
 Test chamber stability with artificial snowflake
 Zero recorder (wind 0, IAT 30, OAT 40)

Operations

Take RH measurement of chamber air
 Record date, place of observation, chart speed, film roll number,
 RH values
 Check generator oil/gasoline level approximately hourly

Closing Down

Outside worker

Remove jacks
 Take down OAT shelter and put probe back
 Remove opening controls and/or entrance tunnel
 Clean snow off top and truck
 Position canvas for transportation

Inside worker

Turn off water pump (vacuum and heater should remain running to
 dry out the chamber)
 Photographic system
 Remove film
 Turn everything OFF
 Remove cameras from mounts
 Turn off equipment in instrument box
 Remove pens, data, and thermos insert
 Put OAT probe in instrument box, put on cover
 Remove inside air temperature/marker plugs from box
 Place foam rubber around box
 Put all data, camera system, thermos insert, used film and other
 materials to be taken inside in one container

Attach tiedown ropes

Shut off generator
 Put generator, gasoline, step stool and electrical cord in truck
 Turn vacuum and heater switches off
 Remove cooler and drain clamp (attach to extension cord)
 Walk around site for final check

Appendix E

ELECTRICAL SYSTEMS

This appendix describes how all the equipment used in our apparatus is connected.

Instrument Box

The power to the apparatus is supplied by a portable alternator, described in Chapter 4. From a single connection on the instrument box, power is supplied to eight grounded outlets, from which the equipment obtain their power. Two of these outlets, the ones providing power to the heater and the conditioning system's water pump, are controlled by a switch located on the front of the instrument box.

Conditioning System Water Pump

This pump's circuitry is equipped with an on/off switch located on the front of the instrument box which enables the operator to more easily control the pump's operation.

Heater

The heater's circuitry is also equipped with an on/off switch located on the front of the instrument box.

Photographic Lighting System

General lighting for photography is provided by a quartz-halogen automobile driving light. The DC power for this light is provided

by a battery charger. Additional lighting is provided by an Olympus electronic flash, powered with an AC adapter. This flash is controlled through an electrical connection with the top camera. The cameras are electrically connected to a switch which causes them to fire simultaneously.

Recorder

The three channels of the recorder record the air velocity, the temperature in the apparatus and the outside air temperature. The upper channel is also wired so that when a switch is depressed, in conjunction with another switch which fires the cameras, this channel is shorted out, which makes an effective tick mark on the paper, thus recording the exact moment the photograph was taken.

Appendix F

FALL VELOCITY DETERMINATION

To aid in the determination of the fall velocity, six reference lines were added to the chamber. Their position from the bottom of the suspension chamber is as shown below:

first	18.4 cm
second	21.0
third	23.5
fourth	26.0
fifth	28.6
sixth	1.1

The anemometer probe was located in the suspension chamber exit tube (for reasons explained in Chapter 4). This enables a calculation of the airflow rate to be made. The air was assumed to be incompressible, therefore the same volume of air must flow through the exit tube as flows through the suspension chamber. The only difference is that the airflow is slower because the diameter of the container through which it flows is larger. Just exactly how much larger must be determined for any particular level in the chamber, due to its divergent construction. The radius for each of the six designated levels in the chamber was calculated to be as follows:

first	5.39 cm
second	5.48
third	5.56
fourth	5.65
fifth	5.74
sixth	5.82

With the radius, the area at the probe's position could then be

expressed as a percentage of the area at each designated level in the suspension chamber. The percentage obtained for each of the six levels are:

first	22.2%
second	21.5
third	20.8
fourth	20.2
fifth	19.6
sixth	10.0

Thus, the air velocity at any level can be expressed as a percentage of the measured air velocity. For example, the velocity at the second level is 21.5% of the velocity measured by the anemometer. Through interpolation, the velocity can be determined for any position between the levels.

REFERENCES

- Auer, A. H., Jr., 1975. Precipitation rates for some types of solid hydrometeors. *Weather* 30:336-338.
- Baileu, I. H., and W. C. Macklin, 1968. Heat transfer from artificial hailstones. *Quart. J. Roy. Meteor. Soc.* 94:93-98.
- Battan, L. J., and J. B. Theiss, 1976. Rain resulting from melting snow. *Intl. Conf. on Cloud Physics, Boulder, Colorado.* 567-571.
- Beard, K. V., and H. R. Pruppacher, 1969. A determination of the terminal velocity and drag of a small drop by means of a wind tunnel. *J. Atmos. Sci.* 26:1066-1072.
- Budyko, M. I., 1974. *Climate and Life.* New York: Academic Press.
- Cornford, S. G., 1965. Fall speeds of precipitation elements. *Quart. J. Roy. Meteor. Soc.* 91:91-94.
- Cotton, W. R., and W. R. Gopkhale, 1967. Collision, coalescence and breakup of large water drops in a vertical wind tunnel. *J. Geophys. Res.* 72:4041-4049.
- Drake, J. C., and B. J. Mason, 1966. The melting of small ice spheres and cones. *Quart. J. Roy. Meteor. Soc.* 42:500-509.
- Fukuta, N., L. R. Neubauer, and D. D. Erickson, 1979. Laboratory studies of organic ice nuclei smoke under simulated seeding conditions: ice crystal growth. Final report to NSF under Grant No. ENV 77-15346, January 1979.
- Hoffer, T. E., and S. C. Mallen, 1967. A vertical wind tunnel for small droplet studies. *J. Appl. Meteor.* 7:290-292.
- Iribarne, J. V., and M. Klemes, 1970. Electrification associated with breakup of drops of terminal velocity in air. *J. Atmos. Sci.* 27:927-936.
- Ito, K., T. Yano, and K. Hama, 1953. Size distribution, crystal form and falling velocity of snowflake. *J. Met. Soc. Japan.* 31:219-231.
- Jayaweera, K. O. L. F., and B. J. Mason, 1965. The behavior of freely falling cylinders and cones in a viscous fluid. *J. Fluid. Mech.* 22:709-720.
- Jiusto, J. E., and G. E. Bosworth, 1971. Fall velocity of snowflakes.

- J. Appl. Meteor. 10:1352-1354.
- Kajikawa, M., 1972. Measurement of falling velocity of individual snow crystals. J. Meteor. Soc. Japan 50:577-583.
- _____, 1975. Experimental formula of falling velocity of snow crystals. J. Meteor. Soc. Japan 53:267-271.
- Kinzer, G. D., and R. Gunn, 1951. The evaporation, temperature, and thermal relaxation-time of freely falling waterdrops. J. Meteor. 8:71-83.
- Kinzer, G.D., and W. E. Cobb, 1956. Laboratory measurements of the growth and collection efficiency of raindrops. J. Meteor. 13: 295-301.
- _____, 1958. Laboratory measurements and analysis of the growth and collection efficiency of cloud droplets. J. Meteor. 15:138-148.
- Knight, C.A., 1979. Observations of the morphology of melting snow. J. Atmos. Sci. 36:1123-1130.
- Kowa, M., 1981. Determination of ice crystal growth parameters in a supercooled cloud tunnel. Masters thesis, University of Utah.
- Langleben, M. P., 1954. The terminal velocity of snowflakes. Quart. J. Roy. Meteor. Soc. 80:174-181.
- List, R., 1959. Design and operation of the Swiss hail tunnel. Geophys. Monograph. 5:310-316.
- List, R., and J. G. Dussault, 1967. Quasi-steady state icing and melting conditions and heat and mass transfer of spherical and spheroidal hailstones. Helvetical Physica Acta. 41:1016-1020.
- Locatelli, J. D., and P. V. Hobbs, 1974. Fall speeds and masses of solid precipitation particles. J. Geophys. Res. 79:2185-2197.
- Longstreth, T. M., 1966. Understanding the Weather. New York: Collier Books.
- Lumb, F. E., 1961. Relation between the terminal velocity and dimensions of snowflakes. Meteor. Mag. 90:344-347.
- Macklin, W. C., 1961. Accretion in mixed clouds. Quart. J. Roy. Meteor. Soc. 87:413-424.
- _____, 1963. Heat transfer from hailstones. Quart. J. Roy. Meteor. Soc. 89:360-369.
- _____, 1963. Factors affecting the heat transfer from hailstones.

- Quart. J. Roy. Meteor. Soc. 90:84-90.
- Magono, C., 1950. On the fall velocity of snowflakes. J. Meteor. Soc. Japan 8:199-200.
- Magono, C., and T. Nakamura, 1965. Aerodynamic studies of falling snowflakes. J. Meteor. Soc. Japan 11:139-147.
- Mason, B. J., 1956. On the melting of hailstones. Quart. J. Roy. Meteor. Soc. 82:209-216.
- _____, 1971. The Physics of Clouds. Cambridge: Oxford University Press.
- _____, 1975. Clouds, Rain and Rainmaking. Cambridge: Oxford University Press.
- Mather, J.R., 1974. Climatology: Fundamentals and Applications. Hightstown, NJ: McGraw-Hill.
- Matsuo, T., and Y. Sasyo, 1981a. Empirical formula for the melting rate of snowflakes. J. Meteor. Soc. Japan 59:1-8.
- _____, 1981b. Melting of snowflakes below freezing level in the atmosphere. J. Meteor. Soc. Japan 59:16-24.
- _____, 1981c. Non-melting phenomena of snowflakes observed in subsaturated air below freezing level. J. Meteor. Soc. Japan 59:26-32.
- O'Brien, H. W., 1970. Visibility and light attenuation in falling snow. J. Appl. Meteor. 9:671-683.
- Ohtake, T., 1965. Preliminary observations of size distribution of snowflakes and raindrops at just above and below the melting layer. Proc. Intl. Conf. on Cloud Physics, Tokyo, Japan. 271-275.
- _____, 1969. Observations of size distributions of hydrometeors through the melting layer. J. Atmos. Sci. 26:545-557.
- Pankhurst, R. C., and D. W. Holder, 1952. Wind Tunnel Technique. London: Sir Isaac Pittman and Sons, LTD.
- Pflaum, J. C., and H. R. Pruppacher, 1979. A wind tunnel investigation of the growth of graupel initiated from frozen drops. J. Atmos. Sci. 36:680-688.
- Pitter, R. L., and H. R. Pruppacher, 1973. A wind tunnel investigation of freezing of small drops falling at terminal velocity in air. Quart. J. Roy. Meteor. Soc. 99:540-55.

- Pope, A., 1954. Wind-Tunnel Testing. New York: John Wiley & Sons.
- Pope, A., and J. J. Harper, 1966. Low Speed Wind Tunnel Testing. New York: John Wiley & Sons, Inc.
- Pruppacher, H. R., and M. Neiburger, 1968. The UCLA cloud tunnel. Proc. Intl. Conf. Cloud Physics, Toronto. 389-392.
- Pruppacher, H. R., and K. V. Beard, 1975. A wind tunnel investigation of the internal circulation and shape of water drops falling at terminal velocity in air. Quart. J. Roy. Meteor. Soc. 96:247-256.
- Pruppacher, H. T., and R. Rasmussen, 1979. A wind tunnel investigation of the rate of evaporation of large water drops falling at terminal velocity in air. J. Atmos. Sci. 36:1255-1260.
- Roberts, W. O., and H. Lansford, 1979. The Climate Mandate. San Francisco: W. H. Freeman and Company.
- Rogers, R. R., 1979. A Short Course in Cloud Physics. 2nd edition. Elmsford, N.Y.: Pergamon Press.
- Sasyo, Y., and T. Matsuo, 1980. On the statistical investigation of fall velocity of snowflakes. Pap. Met. Geophys. 31:61-79.
- Savage, R. C., 1982. Melting of natural ice crystals suspended in a vertical wind tunnel. Masters thesis, University of Utah.
- Taylor, G. F., 1954. Elementary Meteorology. Englewood Cliffs, NJ: Prentice Hall, Inc.
- Telford, J. W., N. S. Thorndike, and E. G. Bowen, 1955. The coalescence between small water drops. Quart. J. Roy. Meteor. Soc. 81:241-250.
- Weast, Robert C., ed., 1978. CRC Handbook of Chemistry and Physics. West Palm Beach, Florida: CRC Press, Inc.
- Zikmunda, J., and G. Vali, 1972. Fall patterns and fall velocities of rimed ice crystals. J. Atmos. Sci. 29:1334-1335.
- _____, 1972. Fall velocities of spatial crystals and aggregates. J. Atmos. Sci. 29:1511-1515.

VITA

Name	Gregory James Donovan
Birthplace	Yankton, South Dakota
Birthdate	25 August 1952
High School	Bonneville High School Ogden, Utah
Universities	Utah State University Logan, Utah 1970-1974 University of Utah Salt Lake City, Utah 1974-1975
Degrees	Bachelor of Science Mathematics, 1974 Utah State University Bachelor of Science Meteorology, 1975 University of Utah
Professional and Honorary Organizations	American Meteorological Society Chi Epsilon Pi
Professional Position	Weather Officer United States Air Force

