

AD-A116 800

NAVAL WEAPONS CENTER CHINA LAKE CA
ULTRAVIOLET ENHANCED DEPOSITION FROM PENTACARBONYL-IRON ON GALL--ETC(U)
OCT 81 N BOTTKA, P WALSH
NWC-TP-6323

F/G 20/12

UNCLASSIFIED

NL

1-1
6-80

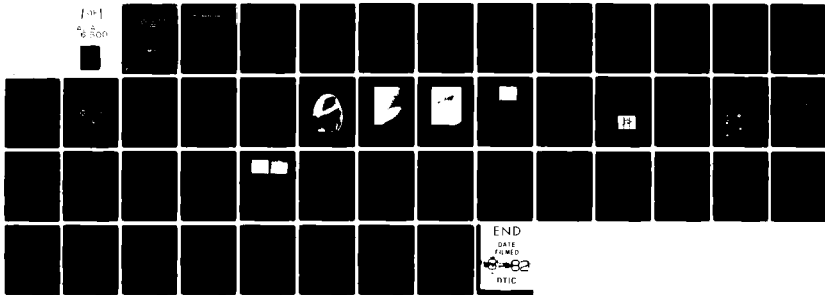

END
DATE
FILMED
BY
DTIC

AD A116800

NWC TP 6323

13

Ultraviolet Enhanced Deposition From Pentacarbonyl-Iron on Gallium Arsenide, Quartz, and Sapphire

by
N. Bottka
Research Department
Naval Weapons Center
and
P. Walsh
Physics Department
Fairleigh Dickenson University

OCTOBER 1981

NAVAL WEAPONS CENTER
CHINA LAKE, CALIFORNIA 93555



Approved for public release; distribution unlimited.

DTIC
ELECTE
JUL 9 1982
S B D

82 07 09 012

DTIC FILE COPY

Naval Weapons Center

AN ACTIVITY OF THE NAVAL MATERIAL COMMAND

FOREWORD

The research described in this report was performed during fiscal year 1981 and was supported by the Office of Naval Research, under Task Number RR02102; the Naval Electronics Systems Command, under Task Number ZF6258; and the Director of Navy Laboratories, under Task Number ZR00001.

The report describes new methods for depositing elemental iron films on semiconductors from organo-metallic compounds at substantially reduced temperatures.

Dr. V. Rehn has reviewed this report for technical accuracy.

Approved by
E. B. ROYCE, *Head*
Research Department
9 October 1981

Under authority of
J. J. LAHR
Capt., U. S. Navy
Commander

Released for publication by
R. M. HILLYER
Technical Director

NWC Technical Publication 6323

Published by Technical Information Department
Collation Cover, 23 leaves
First printing 50 unnumbered copies

UNCLASSIFIED

SECURITY CLASSIFICATION OF THIS PAGE (When Data Entered)

REPORT DOCUMENTATION PAGE		READ INSTRUCTIONS BEFORE COMPLETING FORM
1. REPORT NUMBER NWC TP 6323	2. GOVT ACCESSION NO. AT-1116866	3. RECIPIENT'S CATALOG NUMBER
4. TITLE (and Subtitle) ULTRAVIOLET ENHANCED DEPOSITION FROM PENTACARBONYL-IRON ON GALLIUM ARSENIDE, QUARTZ, AND SAPPHIRE		5. TYPE OF REPORT & PERIOD COVERED Summary report June-August 1981
		6. PERFORMING ORG. REPORT NUMBER
7. AUTHOR(s) N. Bottka and P. Walsh		8. CONTRACT OR GRANT NUMBER(s)
9. PERFORMING ORGANIZATION NAME AND ADDRESS Naval Weapons Center China Lake, CA 93555		10. PROGRAM ELEMENT, PROJECT, TASK AREA & WORK UNIT NUMBERS RR02102 17 J F62581 ZR00001
11. CONTROLLING OFFICE NAME AND ADDRESS Naval Weapons Center China Lake, CA 93555		12. REPORT DATE October 1981
		13. NUMBER OF PAGES 44
14. MONITORING AGENCY NAME & ADDRESS (if different from Controlling Office)		15. SECURITY CLASS. (of this report) UNCLASSIFIED
		15a. DECLASSIFICATION/DOWNGRADING SCHEDULE
16. DISTRIBUTION STATEMENT (of this Report) Approved for public release; distribution unlimited.		
17. DISTRIBUTION STATEMENT (of the abstract entered in Block 20, if different from Report)		
18. SUPPLEMENTARY NOTES		
19. KEY WORDS (Continue on reverse side if necessary and identify by block number) Organo-metals Pyrolysis Iron Epitaxy Gallium arsenide Photolysis		
20. ABSTRACT (Continue on reverse side if necessary and identify by block number) See back of form.		

DD FORM 1473
1 JAN 73EDITION OF 1 NOV 68 IS OBSOLETE
S/N 0102-LF-014-6601

UNCLASSIFIED

SECURITY CLASSIFICATION OF THIS PAGE (When Data Entered)

UNCLASSIFIED

SECURITY CLASSIFICATION OF THIS PAGE (When Data Entered)

(U) *Ultraviolet Enhanced Deposition From Pentacarbonyl-Iron on Gallium Arsenide, Quartz, and Sapphire* (U), by N. Bottka and P. Walsh. China Lake, Calif., Naval Weapons Center, October 1981. 44 pp. (NWC TP 6323, publication UNCLASSIFIED.)

(U) This report assesses the potential utilization of organo-metals in the thin-film deposition of metals, semiconductors, and insulators onto various substrates. The emphasis is on the particular advantages of the ultraviolet photolysis of organo-metals using incoherent light for low temperature, wide-area deposition of thin films. Experimental results on the photolysis and pyrolysis of pentacarbonyl-iron on gallium arsenide, quartz, and sapphire are reported.

Accession For	
NTIS GRA&I	<input checked="" type="checkbox"/>
DTIC TAB	<input type="checkbox"/>
Unannounced	<input type="checkbox"/>
Justification	
By	
Distribution/	
Availability Codes	
Avail and/or	
Dist	Special
A	

LTIC
COPY
INSPECTED
3

UNCLASSIFIED

SECURITY CLASSIFICATION OF THIS PAGE (When Data Entered)

CONTENTS

Acknowledgments	2
Executive Summary	3
Organo-Metal Deposition of Thin Films	4
Pentacarbonyl-Iron	8
Flow Experiments	12
Vacuum Experiments at Low Temperature on Quartz and Sapphire	18
Deposition From $\text{Fe}(\text{CO})_5$ Vapor Onto Quartz by Photolysis at Room Temperature	20
Deposition From Adsorbed $\text{Fe}(\text{CO})_5$ Onto Sapphire by Photolysis at Dry-Ice-Acetone Temperature	22
Deposition From Adsorbed $\text{Fe}(\text{CO})_5$ Onto GaAs (100) by Photolysis at Liquid Nitrogen Temperature	22
Recommendations	28
Appendixes:	
A. Toxicity of Pentacarbonyl-Iron	31
B. Monolayer Formation Rate for an Adsorbed Species as a Function of Pressure	32
C. UV Flux Required for Photodissociation of a $\text{Fe}(\text{CO})_5$ Film of Given Thickness	33
D. Monolayers of $\text{Fe}(\text{CO})_5$ Formed on a Substrate for a Given Pressure and Volume of $\text{Fe}(\text{CO})_5$	35
E. Patent Disclosure for the UV Photolysis of Compounds to Produce Pure Films With Controlled Growth Properties	36
F. Memorandum Reporting Visit to Rockwell International, Metal Organic Laboratory	42

ACKNOWLEDGMENTS

We wish to acknowledge the aid given us by the following Naval Weapons Center personnel: Richard Gleeson, for assisting us in utilizing his $\text{Fe}(\text{CO})_5$ flow reactor and many helpful discussions; Robert Dalbey and M. Hills, for substantial technical assistance; Richard Veneski, for his skillful preparation of the $\text{Fe}(\text{CO})_5$; John Dancy and Jim Bethke, for their aid in microscope analysis; and Victor Rehn, Richard Rosenberg, and W. Thun, for their helpful discussions.

Our gratitude is also expressed to Dr. H. Manasevit, of Rockwell International, for his particularly helpful discussions. Dr. Manasevit is a pioneer in the area of organo-metals.

EXECUTIVE SUMMARY

This report summarizes the results of a ten-week Naval Weapons Center-American Society for Engineering Education (NWC-ASEE) project aimed at assessing the potential utilization of organo-metals (OM) in the thin-film deposition of metals, semiconductors, and insulators onto various substrates. The report emphasizes the particular advantages of the ultraviolet (UV) photolysis of OM using incoherent light for the low temperature, wide-area deposition of thin films.

In addition to assessing the state of the art of this area of research, experiments were performed using pentacarbonyl-iron ($\text{Fe}(\text{CO})_5$) to produce iron (Fe) films on gallium arsenide (GaAs), quartz, and sapphire by photolysis. Films were deposited on GaAs in both flow and vacuum experiments.

It is shown that $\text{Fe}(\text{CO})_5$ can be adsorbed on a substrate at low temperatures and subsequently photolyzed to yield monolayer by monolayer coverage of Fe film. This technique offers the possibility of controlled growth of very thin, pure Fe films upon GaAs substrates.

The flow experiments at higher temperatures show that the mechanism of Fe formation on GaAs is a combination of pyrolysis and photolysis. The resulting Fe films were polycrystalline. It is expected that with proper control of flow and temperature, very uniform epitaxial films of Fe on GaAs will be possible. Such high-quality ferromagnetic films may be important in the development of low-scatter mirrors for laser gyros.

The report concludes by recommending that research effort should be focused on the synthesis of new OM compounds which incorporate the desired target molecule (to be deposited) directly into the host organic species. This would allow deposition of compounds such as zinc selenide (ZnSe) and titanium dioxide (TiO_2) from a single OM system. These single systems, when combined with photolysis techniques, may offer low temperature deposition of stoichiometric films. Such deposition schemes may be very useful not only in the metallization and passivation of temperature-sensitive semiconductors such as mercury-cadmium-telluride (HgCdTe), but may ultimately allow the synthesis of such semiconductors at much lower temperatures.

ORGANO-METAL DEPOSITION OF THIN FILMS

Throughout this report we will use the term organo-metals (OM) to include a broad class of compounds in which a "target" molecule, e.g., gallium (Ga), Fe, ZnSe, or TiO_2 , is incorporated within a host system. The host system may be a traditional organic complex such as one of the alkyls, e.g., (CH_3) , or it may be a carbonyl, e.g., (CO) .

The technique of organo-metals chemical vapor deposition (OM-CVD) has received considerable attention because of its usefulness in thin-film deposition.¹⁻⁹ Following are some advantages of OM in CVD. They are (1) stable carriers at room temperature, (2) easily decomposed, (3) easily purified, (4) high-vapor pressure liquids, (5) easily adapted to flow in low- and high-pressure systems, (6) compatible with conventional reactor systems, and (7) partial getters of oxygen (O_2) and water (H_2O). Table 1 lists some of the common available OM with some of their physical properties. Table 2 lists some of the materials that have been deposited using OM-CVD, along with the OM species used.

In spite of the considerable research, however, the full potential of OM-CVD has not been realized. In particular, it may be possible to directly deposit not only elemental systems (such as Fe films) from a single OM but also complex molecular systems (such as ZnSe, mercury telluride (HgTe), and TiO_2) from a single OM specie.^{8,9} Thus, it may be possible to form thin metal, semiconductor, or insulator films in a single deposition step involving only one OM specie.

The conventional OM-CVD technique is essentially a pyrolytic technique in which heat is used to initiate the chemical reactions near a substrate on which the desired film is to be deposited.⁴⁻⁶ With films such as GaAs, at least two chemical species are required, e.g., trimethyl gallium ($(\text{CH}_3)_3\text{Ga}$) and arsine (AsH_3). The temperature-governed interaction of the two species does not allow a simple control of the

¹ 23rd Annual Electronic Materials Conference, 24-26 June 1981, University of California, Santa Barbara, Calif.

² H. M. Manasevit and others. Final Report 1979-1980, U.S. Department of Energy, Contract AC02-79ET23004.

³ D. J. Ehrlich, R. M. Osgood, and T. F. Deutsch. *Appl. Phys. Lett.*, Vol. 36 (1980), p. 698.

⁴ H. M. Manasevit and W. I. Simpson. *J. Electrochem. Soc., Solid State Sci.*, Vol. 116 (1969), p. 1725.

⁵ H. M. Manasevit and W. I. Simpson. *Ibid.*, Vol. 118 (1971), p. 644.

⁶ H. M. Manasevit and W. I. Simpson. *Ibid.*, p. 647.

⁷ H. M. Manasevit. *Appl. Phys. Lett.*, Vol. 12 (1968), p. 156.

⁸ International Conference on Metalorganic Vapor Phase Epitaxy, Corsica, France, 4-6 May 1981.

⁹ W. Stutius. *Appl. Phys. Lett.*, Vol. 33 (1978), p. 656.

TABLE 1. Some Common Organo-Metals and Their Physical Properties (After References 10 and 11).

Name	Formula	Melting point, °C, or state	Boiling point, °C	Density gm/cm ³	Refractive index, n
Dimethyl cadmium	(CH ₃) ₂ Cd	-2.5	105.5	1.95	1.59
Dimethyl diselenide	(CH ₃) ₂ Se ₂	liq	153-5
Dimethyl selenide	(CH ₃) ₂ Se	liq	57-8	1.41	...
Dimethyl telluride	(CH ₃) ₂ Te	-10	91-2
Dimethyl zinc	(CH ₃) ₂ Zn	-29	46	1.39	...
Diphenyl mercury	(C ₆ H ₅) ₂ Hg	124-5	>306 dec	2.32	...
Trimethyl aluminum	(CH ₃) ₃ Al	15.4	20/8 mm	0.752	1.43
Trimethyl bismuth	Bi(CH ₃) ₃	-107.7	100	2.30	...
Trimethyl gallium	(CH ₃) ₃ Ga	-19	55.7
Tetramethyl tin	(CH ₃) ₄ Sn	liq	26.5	0.651	1.36
Triphenyl bismuth	(C ₆ H ₅) ₃ Bi	78	...	1.59	...
Diethyl mercury	(C ₂ H ₅) ₂ Hg	liq	159	2.45	1.55
Diethyl selenide	(C ₂ H ₅) ₂ Se	liq	108	1.23	1.48
Diethyl telluride	(C ₂ H ₅) ₂ Te	liq	136-8	1.60	1.52
Diethyl zinc	(C ₂ H ₅) ₂ Zn	-28	118	1.21	...
Tetracarbonyl nickel	Ni(CO) ₄	-25	43	1.31	...
Pentacarbonyl iron	Fe(CO) ₅	-20	103	1.44	...
Hexacarbonyl chromium	Cr(CO) ₆	153	147	1.77	...
Hexacarbonyl molybdenum	Mo(CO) ₆	148	155	1.96	...
Hexacarbonyl vanadium	V(CO) ₆
Hexacarbonyl tungsten	W(CO) ₆	169	175	2.65	...
Octacarbonyl cobalt	Co ₂ (CO) ₈	...	51	1.82	...

stoichiometry of the film to be deposited. The heat required also produces additional impurities due to the outgassing of the system and the substrate. Additional chemical reactions which are not easily controlled are also present.

Instead of using pyrolytic decomposition to deposit the target molecule from the OM, light-induced photolytic decomposition can be utilized. The advantages of photolysis include (1) more selective control on the deposition site, (2) more selective control on the rate of OM deposition, (3) lower temperature depositions than pyrolysis, and

¹⁰ Alpha Catalogue, 1975-76 (Ventron Corp., Danvers, Mass.).

¹¹ V. L. Volkov, V. G. Syrkin, and E. S. Tolmaskii. *Iron Carbonyl*. Moscow, Metallurgis, 1969 (in Russian).

TABLE 2. Examples of Materials Deposited by Organo-Metals
Chemical Vapor Deposition.

Material	Sources used	References
GaAs	TMGa + arsine	4,7,12,13
InP	TMin + phosphine	2,14,15,16
GaP	TMGa + phosphine	4
GaAs _{1-x} P _x	TMGa + arsine + phosphine	4
GaAs _{1-x} Sb _x	TMGa + arsine + stibine	4,8
Ga _{1-x} Al _x As	TMGa + TMAI + arsine	17,18,12
In _{1-x} Ga _x P	TMin + TMGa + phosphine	8
Ga _{1-x} Al _x P	DMGa + TMAI + phosphine	8
ZnSe	DMZn + H ₂ Se	5,9
ZnS	DMZn + H ₂ S	5
CdS	DMCd + H ₂ S	5
CdSe	DMCd + H ₂ Se	5
HgTe	DEHg + DETe	8
CdTe	DMCd + DETe	8
TiO ₂	TiCl ₄ + H ₂ CO ₂	19
ZnSiAs ₂	DMZn + arsine + Si (substrate)	8

(4) the possible formation of ultrapure thin films of precise stoichiometry and epitaxy.

- ¹² R. D. Dupuis and others. *Appl. Phys. Lett.*, Vol. 31 (1977), p. 201.
- ¹³ J. P. Duchemin and others. *J. Electrochem. Soc.*, Vol. 126 (1979), p. 1134.
- ¹⁴ H. Renz and others. *Electron. Lett.*, Vol. 16 (1980), p. 121.
- ¹⁵ P. Moutou and others. *Proceedings of the International Symposium on GaAs and Related Compounds*, 1978, Institute of Physics Conference Series 45, p. 452.
- ¹⁶ J. P. Duchemin and others. *Ibid.*, pp. 10-18.
- ¹⁷ R. D. Dupuis, P. D. Dapkus, and N. Holonyak. *Appl. Phys. Lett.*, Vol. 37 (1979), p. 487.
- ¹⁸ H. M. Manasevit and W. I. Simpson. *J. Electrochem. Soc.*, Vol. 120 (1973), p. 135.
- ¹⁹ S. D. Allen. *IEEE J. Quantum Electron.*, Vol. QE-15 (1979), p. 430.

As an example, lasers have been used to produce finely localized metallization by photolysis of OM containing cadmium (Cd), aluminum (Al), and refractory metals both on semiconductors and insulators.²⁰⁻²³ An ultimate aim of these types of experiments is to achieve single-step submicrometer size metallization and doping patterns on very large-scale integrated circuits without recourse to multistep lithography. In the photolysis of OM by lasers, the laser beam is commonly focused to a small area. This may produce intense local heating of the substrate, vapor, or deposited film during the photolysis. Thus, laser deposition photolysis may often include a substantial contribution from pyrolysis of the OM.

Although the chemistry of photochemical decomposition of OM is well known in the gaseous phase, the physics and chemistry of OM photolysis at gas-solid interfaces, as illustrated above, are still not well understood. Furthermore, most of the photolysis experiments on the film deposition from OM have been done using lasers. For wide-area film deposition, however, lasers are not as practical as incoherent radiation sources which produce wide-area visible and UV illumination efficiently.

In view of the above, we chose as our objective to investigate the wide-area deposition of thin films from OM using incoherent UV radiation on various substrates.

In order to carry through a complete experiment within the limited ten-week span available, we concentrated our efforts on one single OM deposition system. We chose thin-film deposition of Fe from $\text{Fe}(\text{CO})_5$, upon GaAs, quartz, and sapphire as our specific objective. $\text{Fe}(\text{CO})_5$ is readily available and has properties which are well cataloged. In addition, the deposition of Fe on GaAs has unique Navy application. Smooth epitaxial films of Fe on highly polished GaAs may serve as low-scattering, magnetic-biased mirrors used in ring laser gyro systems.

There are two general methods for producing thin films on a substrate by photolysis of OM, both of which have been used in the deposition of Fe from $\text{Fe}(\text{CO})_5$ in our experiments:

(1) Photolysis of a OM vapor or gas outside the substrate. In this case, the vapor is decomposed near the surface, and the target molecule

²⁰ T. F. Deutsch and others. *Appl. Phys. Lett.*, Vol. 35 (1979), p. 175.

²¹ D. J. Ehrlich, R. M. Osgood, and T. F. Deutsch. *Appl. Phys. Lett.*, Vol. 36 (1980), p. 916.

²² R. Solanski and others. *Appl. Phys. Lett.*, Vol. 38 (1981), p. 572.

²³ Massachusetts Institute of Technology. Workshop on the Interaction of Laser Radiation with Surfaces for Application to Microelectronics, 4-5 May 1981.

is allowed to migrate to the substrate for deposition as a film. If a UV window is used in the experiment, the film will also build up on the window unless a proper flow of the OM is used.

(2) Photolysis of a OM gas, liquid, or solid absorbed or frozen onto the substrate. The OM may be frozen on a cooled substrate and the remaining gas or vapor pumped out of the deposition hamber. Photolysis can then proceed. If UV windows are used, they should be sufficiently warm to prevent condensing the OM.

In the latter case, by using a combination of low vapor pressure, adsorbed monolayers of OM, and low UV illumination, it is possible to deposit a target film of monolayer or submonolayer thickness. Such controlled growth of large-area films may offer a "poor-man's" version of a molecular beam epitaxy (MBE) system.

PENTACARBONYL-IRON

Pentacarbonyl-iron is the common form of the iron carbonyl. It is a poisonous, light yellow to reddish liquid, with a vapor pressure of approximately 33 torr at room temperature. $\text{Fe}(\text{CO})_5$ decomposes over a range of temperatures from 60 to 250°C and also decomposes in the presence of light. There are at least two intermediate carbonyl products in the normal decomposition of $\text{Fe}(\text{CO})_5$ - $\text{Fe}_2(\text{CO})_9$ and $\text{Fe}_3(\text{CO})_{12}$ - and the final decomposition products, Fe and CO. Table 3 gives some of the atomic properties of the three iron carbonyls and their decomposition sequence by light. Table 4 gives some of the room temperature properties of $\text{Fe}(\text{CO})_5$.

Figure 1 illustrates the bipyramidal shape of $\text{Fe}(\text{CO})_5$ with five CO ligands arranged about the central Fe core. Following is a common rule for the formation of such metal ligands: The sum of the available electrons from the metal plus the available electrons from the ligands equals the next rare gas electron number in the end of the atom period. The Fe atoms have eight electrons available for bonding from their $(3d)^6$ and $(4s)^2$ atomic electrons. Each carbonyl CO group has two lone pair electrons available for bonding. Thus, five CO units allow the crypton rare gas configuration of 18 electrons to surround the Fe atom, and $\text{Fe}(\text{CO})_5$ forms the stable carbonyl ligand molecule. Figure 1 also illustrates the nanocarbonyl dimer and the dodecacarbonyl trimer units.

In detail, the $\text{Fe}(\text{CO})_5$ molecule is built by forming $5(dsp^3)$ hybrids from the eight available Fe atomic states (see Figure 2). Each hybrid overlaps with available atomic states from one carbonyl unit. The overlap involves an sp overlap producing a σ bond with the carbonyl and a d_{xy} Fe orbital with an unfilled antibonding π^* carbonyl orbital. The three carbonyl units in the plane of the bipyramid see a similar environment which is different from the environment of the two-axial carbonyl. Figure 2 illustrates the resulting energy levels schematically.

TABLE 3. Physical Properties of Various Iron Carbonyls and Their Decomposition Sequence (After References 11 and 24).
 Vapor pressure of $\text{Fe}(\text{CO})_5$: $\log_{10} P(\text{torr}) = 8.156 - [1988/T(\text{K})]$.

Carbonyl	Crystal Group	Unit cell parameter, Å			Bond length, Å			Decomp. °C	Melting point, °C	Boiling point, °C	Density, gm/cm ³		
		a	b	c	β	Fe-C	C-O					Fe-O	Fe-Fe
$\text{Fe}(\text{CO})_5$	monoclinic	11.71	6.80	9.28	107.6	1.84	1.15	2.99	...	60-250	-20	103	1.47
$\text{Fe}_2(\text{CO})_9$	hexagonal	6.45	15.98	1.90	1.15	...	2.46	95-110	2.08
$\text{Fe}_3(\text{CO})_{12}$	monoclinic	8.88	11.33	17.40	98.0	2.75	140	2.00

Decomposition with heat or UV light:

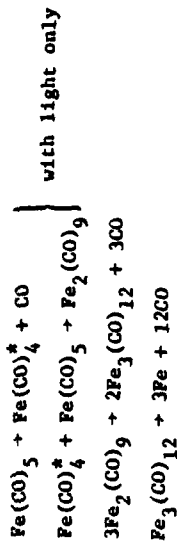

²⁴ K. Scholzel. Method of Applying a Ferromagnetic Surface to a Base Utilizing Iron Carbonyl and Oxygen. 1959. (U.S. Patent 2,919,207, UNCLASSIFIED.)

TABLE 4. Room Temperature Properties of $\text{Fe}(\text{CO})_5$ (After Reference 11).

Property	Value	Units
Density	1.47	gm/cm^3
Surface tension	25	dyne/cm
Viscosity	0.7 (liq)	centipoise
	8×10^{-5} (vapor)	poise
Coefficient thermal expansion	1.28×10^{-4}	1/K
Thermal conductivity	1.25×10^{-3} (liq)	joule (cm-s/K)
	8.36×10^{-5} (vapor)	
Diffusion coefficient in CO at 1 atmosphere	6.20×10^6	cm^2/s

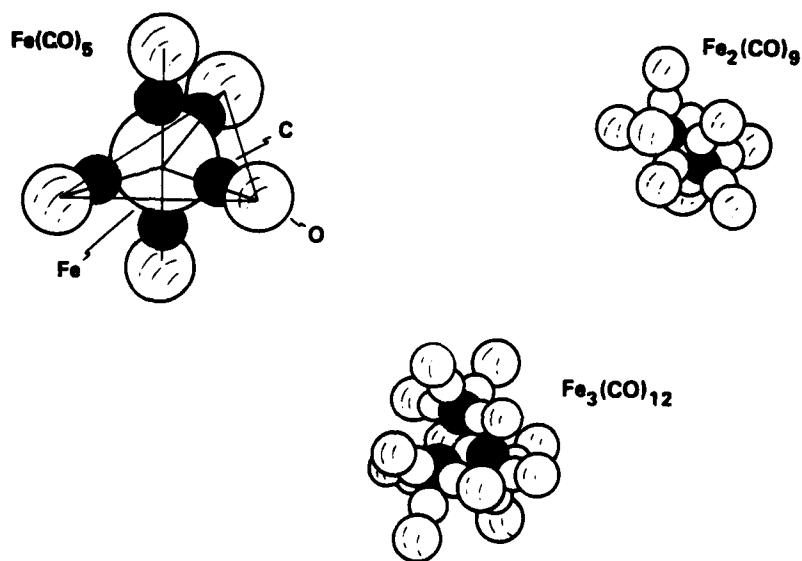

FIGURE 1. Structure of Various Iron Carbonyls (After Reference 11).

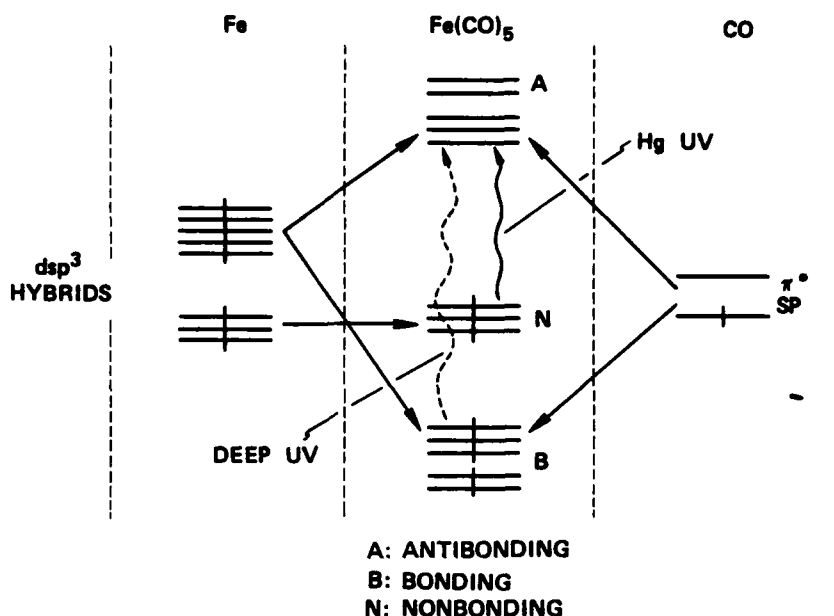

FIGURE 2. Schematic Representation of the Energy Levels of $Fe(CO)_5$. Vertical bar indicates occupied energy levels.

Figure 3 shows the percent absorption of $Fe(CO)_5$ as a function of wavelength at a pressure of 0.4 torr over a path length, ℓ , of 2.8 cm.²⁵ The corresponding absorption cross section, $Q = \beta/B\ell$, of light has been calculated from this data and is also shown. B is the $Fe(CO)_5$ molecular density ($B \approx 3.2 \times 10^{16} P$ (molecules/cm³) at room temperature where the pressure P is in torr), ℓ the path length in centimeters, and β the fractional absorption.

Figure 2 shows schematically the dissociation absorption due to the 253.7-nm line of Hg. This dissociation transition transfers a nonbonding electron to an antibonding orbital with the resulting release of a carbonyl, CO, unit. Five such photon absorptions are required, in principle, to free Fe from the $Fe(CO)_5$. However, absorption of higher energy photons can transfer a bonding electron to an antibonding orbital, as also illustrated in Figure 2. This may produce the simultaneous release of two CO units with one photon. Deeper transition due to still higher energy photons may be possible which might release three, four, or five CO units at once. These transitions may be studied using synchrotron radiation. Practical application of multicarbonyl release may

²⁵ TRW Systems. *Laser-Controlled Chemical Vapor Deposition*, by J. G. Berg. Redondo Beach, Calif., 31 March 1981 (Project 81004302).

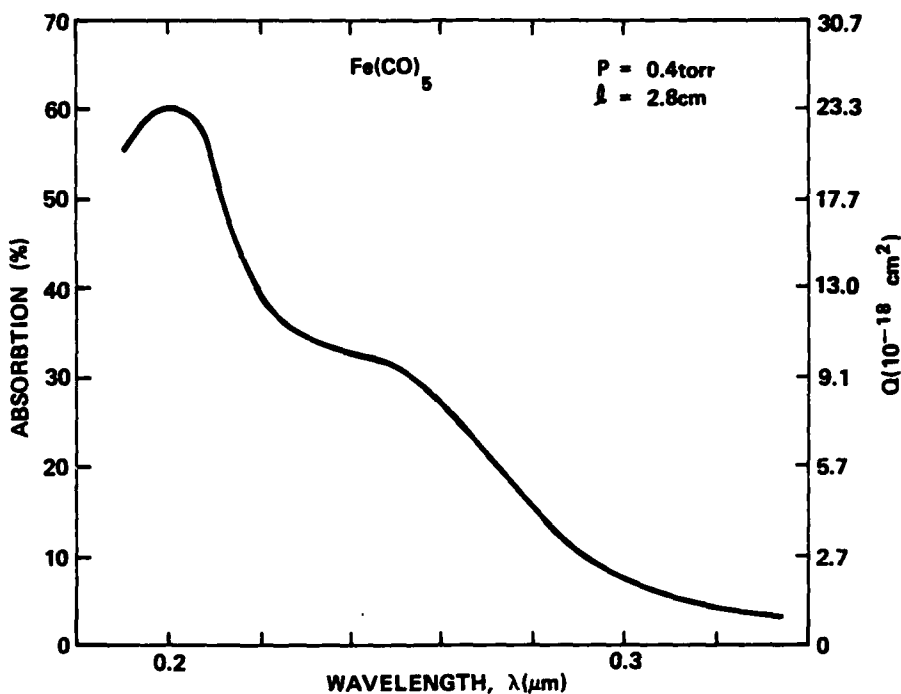

FIGURE 3. Percent Optical Absorption and Optical Cross Section, Q , of Fe(CO)_5 Vapor (After Reference 25).

be implemented using the deep vacuum UV radiation generated in rare gas plasmas. Since these radiations are not transmitted by air or practical window materials, the plasma should be generated within the deposition chamber. Such a system is, in principle, simpler than a sputtering apparatus.

FLOW EXPERIMENTS

The Naval Weapons Center has a facility in which Fe particles can be produced in a flow reactor using Fe(CO)_5 . A schematic of this system is given in Figure 4. Nitrogen (N_2) is preheated to 170°C at atmospheric pressure, and vaporized Fe(CO)_5 is introduced concentrically within the N_2 flow. A xenon (Xe) flash lamp is used to assist the decomposition within the cylindrical quartz chamber.

Several polished (100) GaAs single crystals were introduced at various times into the reactor with their large faces parallel to the laminar N_2 and Fe(CO)_5 flow.

The first sample was exposed to the hot Fe(CO)_5 and a single Xe flash. Figure 5 shows the results of this deposit. A film covers

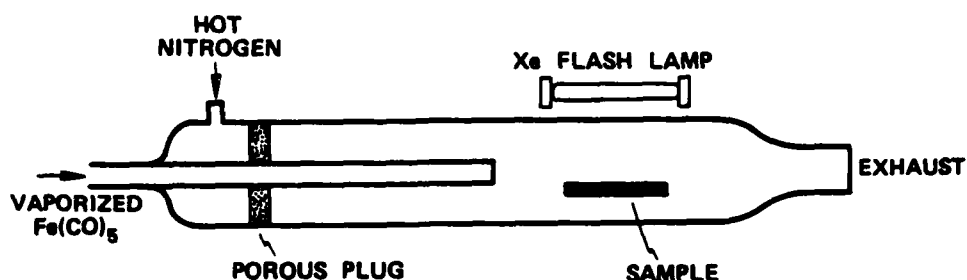

FIGURE 4. Naval Weapons Center $\text{Fe}(\text{CO})_5$ Flow Reactor.

almost all of the surface of the GaAs crystal. Various flow marks and a number of small circular regions are apparent in the photograph. A stripe running across the upper section coincides with a wire used to support the sample in the chamber. Figure 6 shows detail of the flow markings, while Figure 7 illustrates an onion skin growth pattern which is often found with Fe formed from $\text{Fe}(\text{CO})_5$. Figure 8 shows an enlarged circular region featuring a very fine surface particulate deposit that appears to cover the whole surface, which is apparent only under proper illumination.

The film has a shiny metallic appearance. Its reflectivity has been measured as a function of wavelength. The results are shown in Figure 9 along with the reflectivity data of polished Fe and GaAs. The increasing reflectivity with wavelength is usually associated with metallic films. Reflection electron diffraction measurements on this film indicate that it is polycrystalline. It should be noted that recent MBE experiments show that very smooth epitaxial growth of Fe on GaAs occurs at 175°C .²⁶ Talystep data are presented in Figure 10 which indicate an average film thickness of 1680 Å. The observed large surface irregularities apparently coincide with the particulate matter shown in Figure 8. This particulate matter presumably consists of fine Fe particles which are routinely produced in such flow systems. This particulate matter will produce a diffuse component in the reflectivity, thus reducing the observed reflectivity of the film below that of polished Fe (see Figure 9). Although the composition of the film has not been determined, it is undoubtedly Fe. The film has been in the open atmosphere for over two months and shows no sign of tarnishing.

Other GaAs samples were exposed to hot $\text{Fe}(\text{CO})_5$ and numerous Xe flashes. All samples showed film deposition, but nonuniform flow conditions prevented wide, uniform coverage.

²⁶ G. A. Prinz and J. J. Krebs. *Bull. Am Phys. Soc.*, Vol. 26, No. 3 (1981).

Based on these measurements, we conclude that the main decomposition process in these flow experiments is pyrolysis. With a more controlled flow reactor system (such as OM-CVD), the production of high quality Fe films on GaAs may indeed be possible.



FIGURE 5. Film on (100) GaAs Deposited From $\text{Fe}(\text{CO})_5$ at 170°C in a Flow Reactor. Largest dimension of sample is approximately 3 cm.



FIGURE 6. Detail Flow Markings on Film in Figure 5.

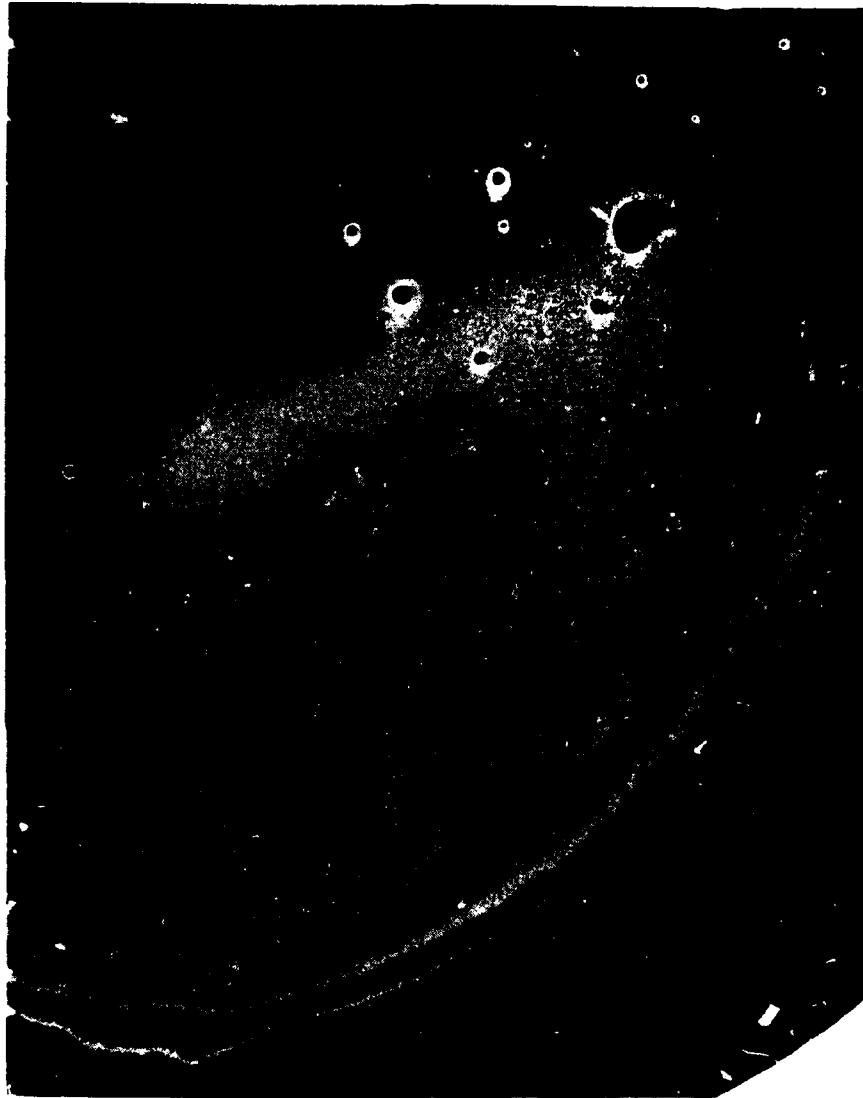

FIGURE 7. Onion Skin Growth Pattern of Film on (100) GaAs.

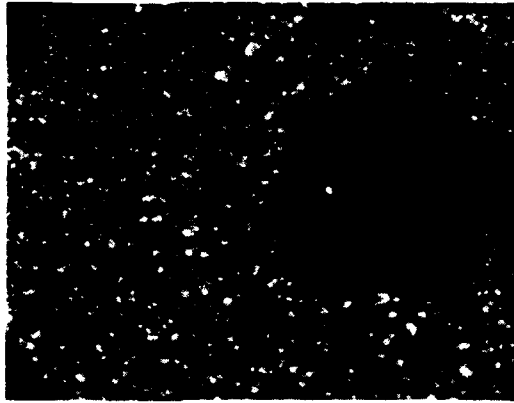

FIGURE 8. Surface Particles Near a Crater Film on (100) GaAs. Magnification 900 on Nomarski microscope.

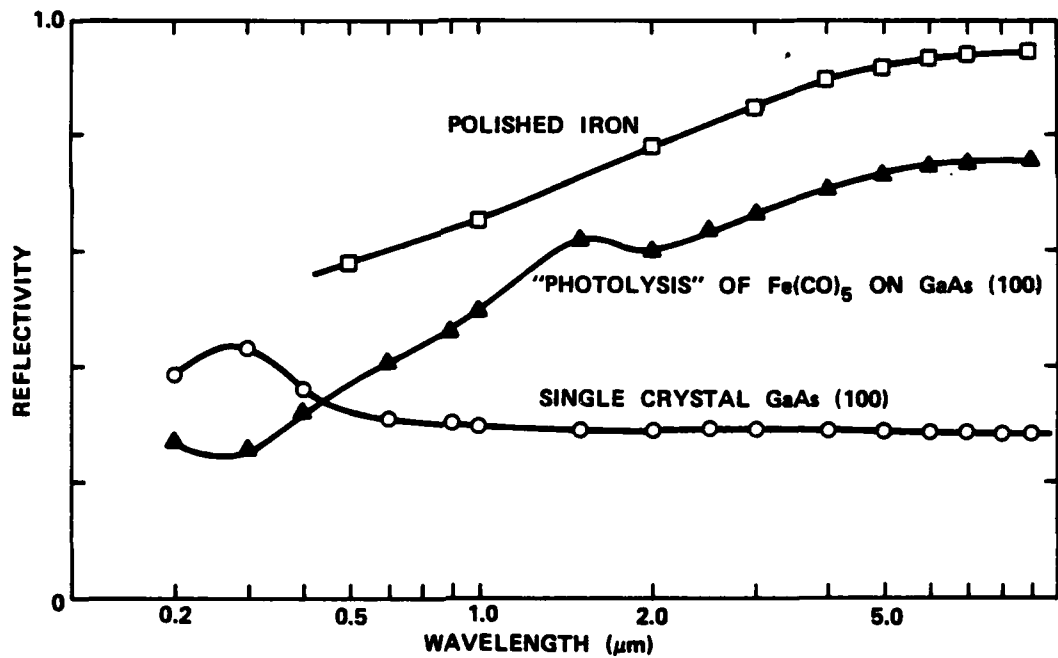

FIGURE 9. Reflectivity Versus Wavelength of Film Deposited From Fe(CO)₅ Onto (100) GaAs Substrate. Reflectivity of polished Fe and single-crystal GaAs.

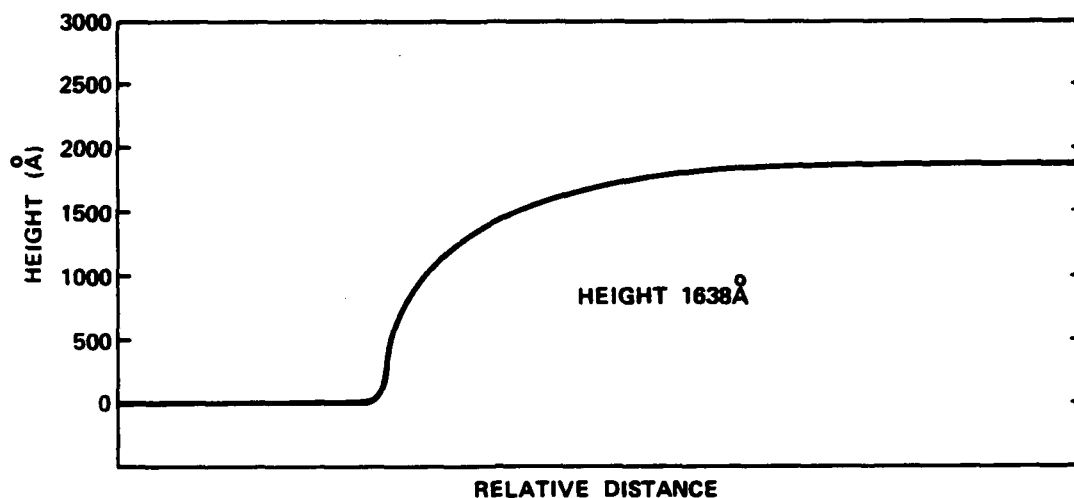

FIGURE 10. Talystep Measurement of an Fe Film on GaAs Grown by Pyrolysis in a $\text{Fe}(\text{CO})_5$ Flow System.

VACUUM EXPERIMENTS AT LOW TEMPERATURE ON QUARTZ AND SAPPHIRE

Figure 11 shows schematically the stainless steel reactor used in the vacuum experiments, along with the dual-beam laser monitoring of the sample reflectance. Figure 12 shows the system in operation. Before the introduction of $\text{Fe}(\text{CO})_5$ into the reactor, the system had a base pressure near 10^{-5} torr with a leak rate of 5×10^{-4} torr/min, as determined by a thermocouple gauge.

The $\text{Fe}(\text{CO})_5$ was distilled in a clean pyrex reactor, and approximately one-half liter was transferred under vacuum into the vacuum-baked stainless steel tank. A liquid- N_2 -cooled zeolite trap was normally used to pump out the system and the $\text{Fe}(\text{CO})_5$ vapors. This proved to be a very practical and efficient way to both evacuate and trap unwanted $\text{Fe}(\text{CO})_5$. At intervals the zeolite was heated and vented into an exhaust chemical hood. It should be noted that $\text{Fe}(\text{CO})_5$ decomposes on contact with air into Fe_2O_3 and CO . Thus, any small residual $\text{Fe}(\text{CO})_5$ from vacuum experiments which have survived the decomposition in the heated zeolite appears to present no toxicity problems. We should caution, however, that any significant spillage of $\text{Fe}(\text{CO})_5$ into the atmosphere is both explosive and highly toxic (see Appendix A). The stainless steel system is compact, sturdy, leak-free, and, except for venting intervals, can be used in normal laboratory environment.

The sample chamber had four windows, two of which were made from quartz UV-grade flats. The sample was mounted on a copper (Cu) cold finger which could be cooled to cryo-bath temperatures. The adsorption

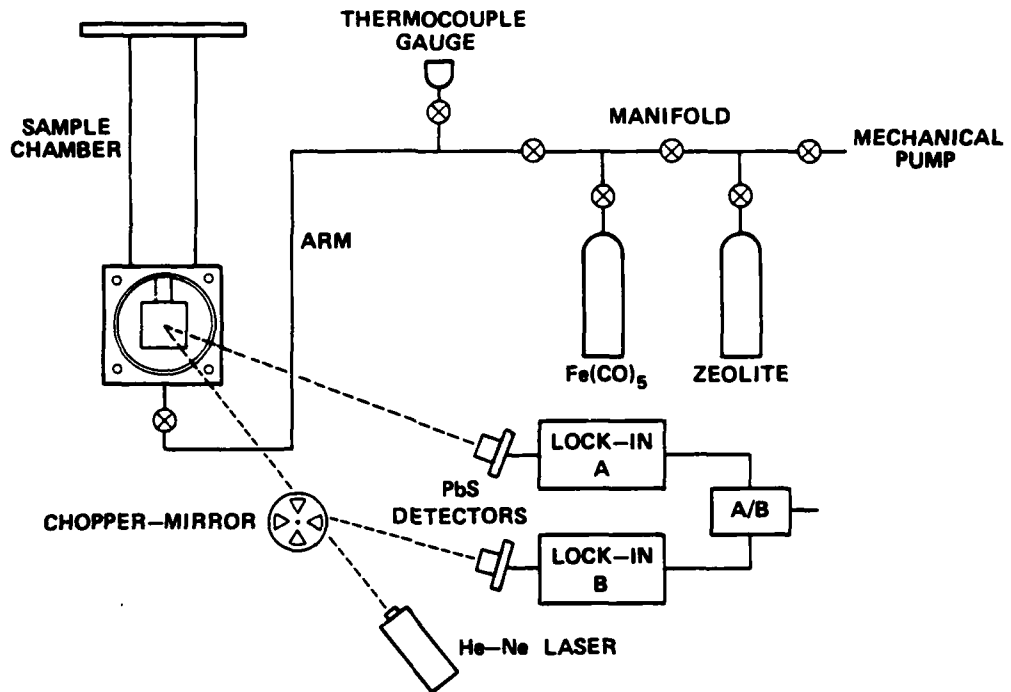

FIGURE 11. Vacuum System, Sample Chamber, and Laser Monitor Schematic Used in the Low Temperature Photodeposition.

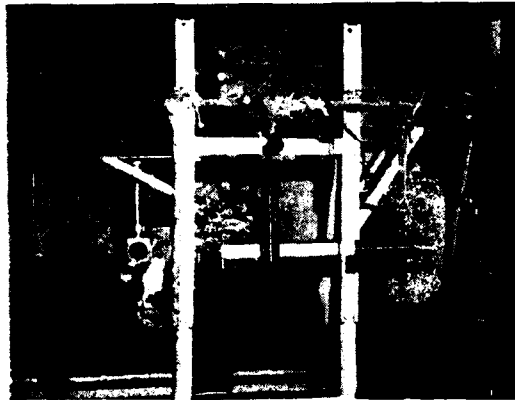

FIGURE 12. Experimental Vacuum System With Sample Chamber, Zeolite Trap, and Laser Monitor.

of $\text{Fe}(\text{CO})_5$ onto the substrate and the formation of films by photolysis were monitored using a helium-neon (He-Ne) laser (the 6328 Å line) with lead sulfide (PbS) detectors and a lock-in technique (see Figure 11). A low-pressure Hg vapor germicidal lamp was used as the UV source for photolysis.*

The vapor pressure of $\text{Fe}(\text{CO})_5$ at room temperature is near 33 torr. The $\text{Fe}(\text{CO})_5$ vapor was introduced into the chamber either at this pressure directly from the $\text{Fe}(\text{CO})_5$ tank or at various reduced pressures by introducing $\text{Fe}(\text{CO})_5$ into various sections of the system. Through a sequence of expansion and evacuations of various portions, a desired low $\text{Fe}(\text{CO})_5$ pressure can be achieved in the sample chamber. Operation at $\text{Fe}(\text{CO})_5$ pressure significantly below 30 torr is desirable to prevent condensation of the vapor at room temperature in unknown portions of the system.

It should be noted that the thermocouple gauge initially used to measure pressures became rapidly contaminated, apparently by thermal decomposition of the $\text{Fe}(\text{CO})_5$ within the gauge. This could have been avoided by heating the tubing leading to the gauge so that the $\text{Fe}(\text{CO})_5$ did not decompose on the gauge element but within the tubing. The experiments performed with this system are listed below.

DEPOSITION FROM $\text{Fe}(\text{CO})_5$ VAPOR ONTO QUARTZ BY PHOTOLYSIS AT ROOM TEMPERATURE

One of the quartz flats serving as a window for the sample chamber was used as the sample substrate in this room temperature photolysis experiment. The chamber was filled directly with $\text{Fe}(\text{CO})_5$ at 33 torr and subsequently exposed for about 1 min. to the UV Hg light. An immediate darkening of the window was observed.

Nomarski microscope examination of this window sample revealed dispersed particles of metallic reflectivity which showed crystalline facets. Figure 13 shows a 360X magnification of a darkened section of this sample. A detailed sequence of a limited region containing several particles is shown in Figure 14a, b, and c. The lens was focused successively from the highest particle to the next highest and then onto the surface. The highest particle (14a) has a crystalline corner facet, while the middle particle (14b) shows a flat truncated triangular facet. We presume that these particles are oxidized on their surfaces. The deposit does not form an apparent film but instead prefers to form many crystal-like particles. This is in apparent agreement with other reports of similar $\text{Fe}(\text{CO})_5$ deposition.²⁷⁻²⁹

* American Ultraviolet Co., Model UFA-4-H, 0.12 amps.

²⁷ J. B. Nagy and others. *J. Catalysis*, Vol. 58 (1979), p. 230.

²⁸ J. Phillips and others. *J. Phys. Chem.*, Vol. 84 (1980), p. 1814.

²⁹ Z. Karny and others. *Chem. Phys. Lett.*, Vol. 59 (1978), p. 33.

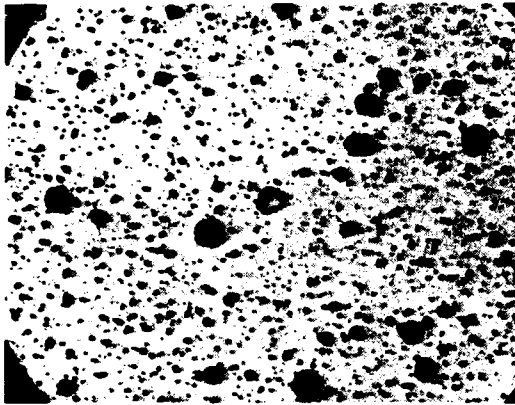
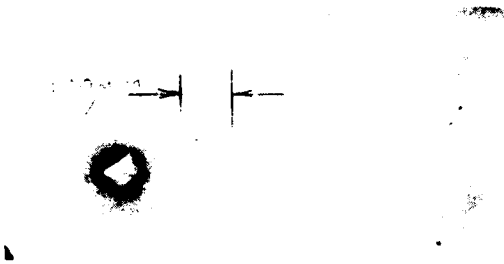
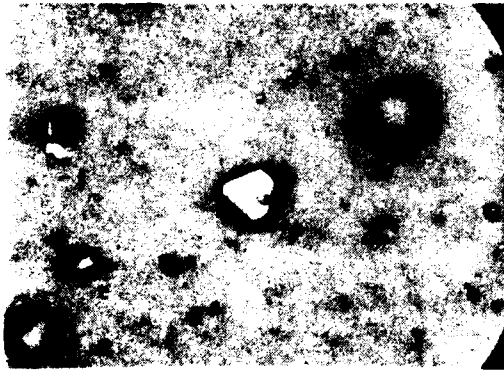

FIGURE 13. Deposit on Quartz by UV Photolysis of $\text{Fe}(\text{CO})_5$ Vapor at 300 K. Magnification 360 on Nomarski microscope.

(a)



(b)



(c)

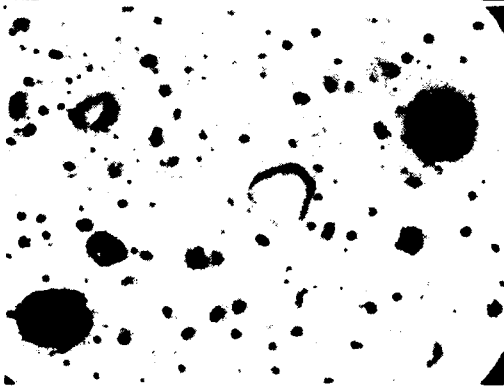

FIGURE 14. Deposit on Quartz by UV Photolysis of $\text{Fe}(\text{CO})_5$ Vapor at 300 K. Magnification 900 on Nomarski microscope, focused on (a) top of highest feature, (b) middle size particle, (c) surface of the quartz.

DEPOSITION FROM ADSORBED $\text{Fe}(\text{CO})_5$ ONTO SAPPHIRE
BY PHOTOLYSIS AT DRY-ICE-ACETONE TEMPERATURE

A sapphire disc was mounted on the sample holder and the cold finger cooled by a dry-ice-acetone bath. The $\text{Fe}(\text{CO})_5$ was introduced into the sample chamber at approximately 3 torr and allowed to adsorb onto the sapphire before the chamber was again evacuated. The sample was then exposed for 10 sec to the Hg lamp. This was repeated ten times after which a final exposure was performed on the $\text{Fe}(\text{CO})_5$ adsorbed at 33 torr onto the sapphire. No obvious wide-coverage film was apparent under microscopic examination. However, two small sections of the sample show an area feature, one of which is shown in Figure 15.

The presence of Fe on this sample is inconclusive. Further analysis is needed to establish the presence of Fe.

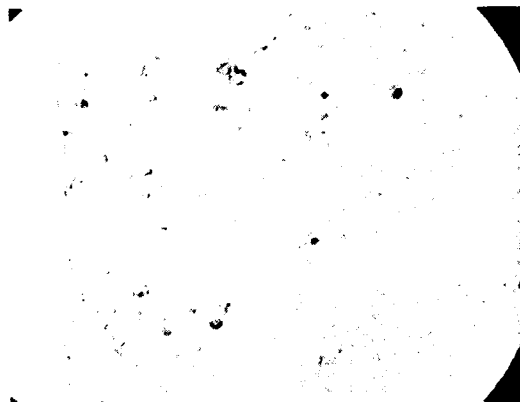

FIGURE 15. Island-Like Feature on Sapphire Deposited by UV Photolysis of $\text{Fe}(\text{CO})_5$ Adsorbed at -80°C . Magnification 360 on Nomarski microscope.

DEPOSITION FROM ADSORBED $\text{Fe}(\text{CO})_5$ ONTO GaAs (100) BY
PHOTOLYSIS AT LIQUID NITROGEN TEMPERATURE

Preliminary experiments were performed to determine the rate of adsorption of $\text{Fe}(\text{CO})_5$ on polished (100) GaAs surfaces. The adsorbed film was monitored by measuring the changes in reflected He-Ne laser intensity on the GaAs surface upon cooling to 77 K (liquid N_2). Figure 16 shows the reflected laser intensity as the (1) sample is first exposed to $\text{Fe}(\text{CO})_5$ vapor at 300 K, (2) chamber is evacuated, and (3) GaAs is cooled to liquid N_2 temperature, again exposed to 33 torr $\text{Fe}(\text{CO})_5$. The sample is allowed to slowly warm up. The results of this adsorption measurements can be summarized as follows.

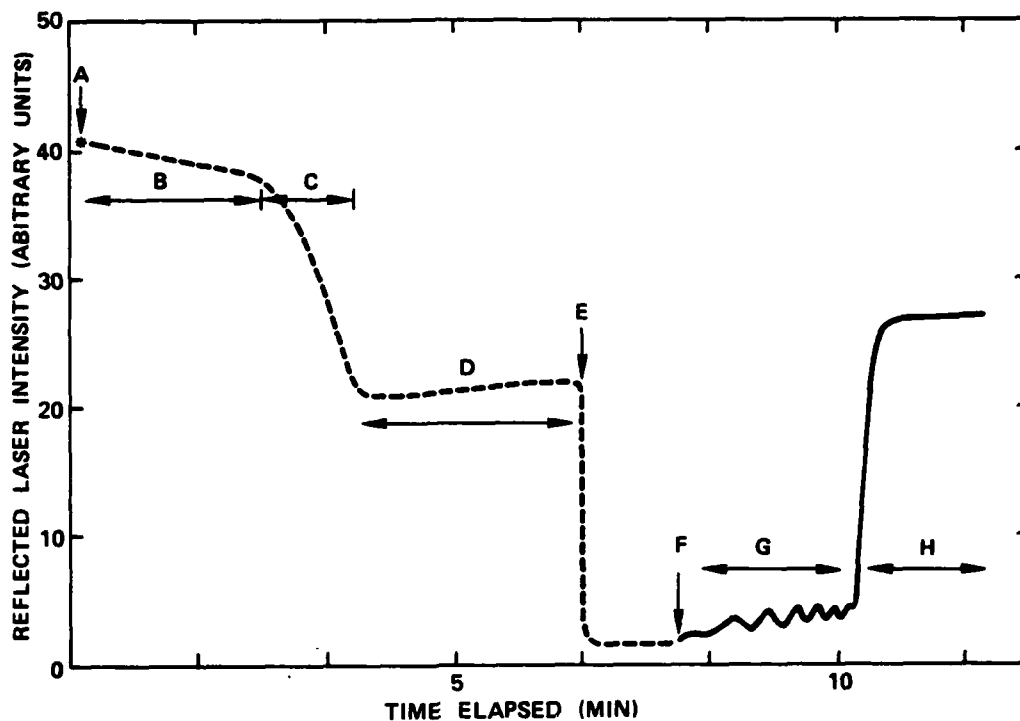

FIGURE 16. Reflected He-Ne Laser Beam Intensity During Adsorption and Desorption of $\text{Fe}(\text{CO})_5$ on GaAs. Following procedures apply: A, chamber evacuated, sample at 300 K; B, introduction of $\text{Fe}(\text{CO})_5$ at 33 torr; C, sample being cooled; D, sample at 77 K; E, introduction of $\text{Fe}(\text{CO})_5$ at 33 torr; F, chamber evacuated; G, desorption of $\text{Fe}(\text{CO})_5$, slow warm-up of sample; H, sample warming up.

(1) $\text{Fe}(\text{CO})_5$ is adsorbed at room temperature, building up a film even after evacuation of the chamber begins. (Pumping the $\text{Fe}(\text{CO})_5$ with zeolite through the 0.25-in. tubing is a very slow process.) The reflected laser intensity drops about 6% during this initial phase. Such drop in reflected laser intensity is expected from a low-index film on a high-index substrate, as is shown in Figure 17, where the relative reflectance of $\text{Fe}(\text{CO})_5$ on GaAs is plotted as a function of $\text{Fe}(\text{CO})_5$ film thickness. For this initial phase, no more than about 200 Å of $\text{Fe}(\text{CO})_5$ is adsorbed.

(2) In the second phase the sample is cooled. There is a fast drop in the reflected laser intensity (about 50%). $\text{Fe}(\text{CO})_5$ appears to be absent from the chamber as the sample reaches liquid N_2 temperature. Thickness of the film is about 700 Å.

(3) $\text{Fe}(\text{CO})_5$ is next introduced into the chamber at 33 torr. The reflected laser intensity drops abruptly. This second, more dramatic,

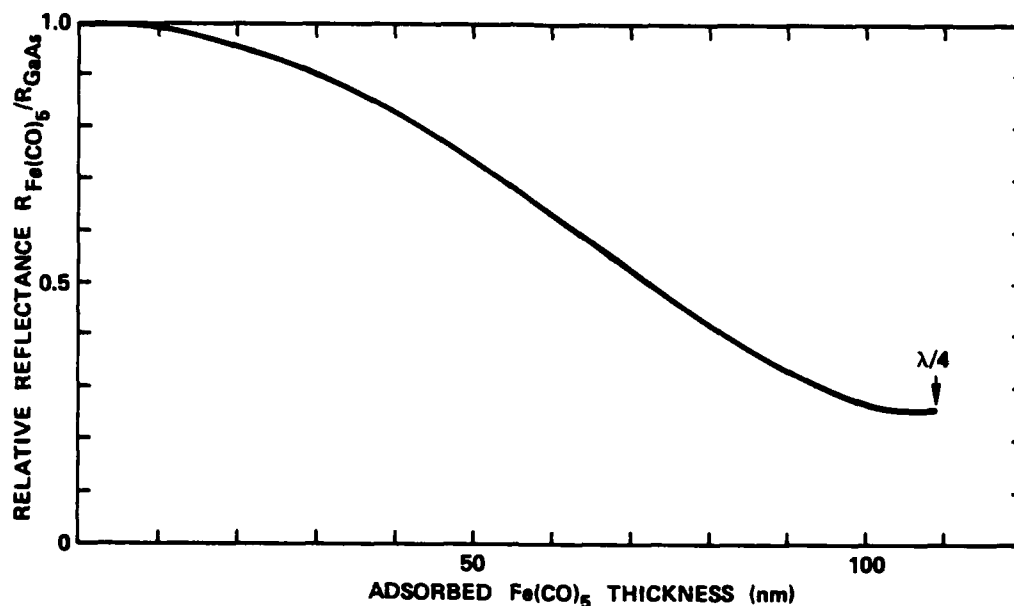

FIGURE 17. Calculated Reflectivity of Fe(CO)₅ Film Upon GaAs at 0.64- μ m Wavelength. Assumed refractive index for GaAs and Fe(CO)₅ was 4.01 and 1.45, respectively.

drop in reflected laser intensity is associated with a frosty diffuse surface. Interference phenomena are masked during this portion of rapid reflectivity drop, due probably to a rapid frost-like film formation of Fe(CO)₅ on GaAs. Appendix B illustrates the rapidity of film buildup at pressures near and above 1 torr. The rapid buildup and "frost" formation were not as dramatic with more controlled cooling.

(4) As the chamber is evacuated, the reflectance begins to undergo amplitude oscillation whose periods decrease from 60 to 25 sec. The Fe(CO)₅ seems to be desorbing from the GaAs surface at a rate slow enough to observe optical interference. It is known from recent adsorption studies of metal alkyls on quartz³⁰ that the first monolayer coverage is strongly bound to the surface. Further monolayers are more weakly bound, and their binding energy is different for each subsequent layer. With pumping, desorption of the molecular layers occur on a fast time scale (< 10 sec). The residual lower layer of the film was found to adhere to the surface and was not removed after more than four hours of pumping at room temperature. Our observed desorption rate (about 5 monolayers/sec or higher) seems to agree with the above-mentioned observations.

³⁰ D. J. Ehrlich and R. M. Osgood. *Chem. Phys. Lett.*, Vol. 79 (1981), p. 381.

(5) Finally, the sample holder begins to warm up, and the reflected laser intensity increases back to the 50% level.

We can conclude from these experiments that with more controlled introduction of $\text{Fe}(\text{CO})_5$ into the chamber, the reflectance technique will remain a useful monitor to determine $\text{Fe}(\text{CO})_5$ film coverage on GaAs.

Photolysis of $\text{Fe}(\text{CO})_5$ film on GaAs was attempted next by introducing approximately 0.4 torr of $\text{Fe}(\text{CO})_5$ into the chamber at room temperature, closing the chamber off and initiating cooling. The reflected laser intensity drops by about 50% upon cooling to liquid N_2 temperature. The sample was exposed with UV for 55 sec. There was a noticeable increase (about 4%) in reflectance. The chamber was evacuated, and a new charge of 0.4 torr of $\text{Fe}(\text{CO})_5$ was introduced into the chamber. The chamber was closed again and cooling maintained. A second exposure of 8 min was performed. Finally, a third charge of 0.4 torr of $\text{Fe}(\text{CO})_5$ was introduced, and a last 5-min UV exposure completed. The sample holder was then allowed to warm up. These steps are summarized in Figure 18.

After the initial UV exposure, a blue-green film was observed on the GaAs surface. This appearance remained after the subsequent exposures. When the sample was brought back near room temperature, interference-like colors were observed on the lower portion of the sample. By the next day, the interference colors had disappeared, and, prior to opening the sample chamber to air, the relative reflectivity of the sample was measured from 0.6 to 1.2 μm . The sample still had a diffuse appearance, and the reflectivity was 30% below that of GaAs across the whole spectrum. On the following day, the sample showed a specular appearance, which to the eye was identical to GaAs.

Upon detailed Nomarski observation at high magnification, wide-area ruptured films were observed on the GaAs surface with strong indication of at least two layers of films on one portion of the sample. Figure 19 shows the rupture film appearance at 800 magnification. A "river"-like feature marks the ruptures between sections of the film through which the smooth GaAs surface apparently is visible. Figure 20 shows these ruptures continuing across a boundary; the portion of the photo on one side of the boundary apparently shows two layers of ruptured films.

Our interpretation of the results of these experiments is that we have photodeposited a thin Fe film atop a relatively thick $\text{Fe}(\text{CO})_5$ film which itself was adsorbed to GaAs. The UV was strongly absorbed in the uppermost $\text{Fe}(\text{CO})_5$ layers. Approximately 110 monolayers of $\text{Fe}(\text{CO})_5$ yield 30% absorption (see Appendixes C and D), and the Fe itself absorbs UV. The Fe film formation is possibly self-limiting so that the thinner $\text{Fe}(\text{CO})_5$ films produced in this experiment are required for direct deposition of Fe on GaAs rather than Fe on $\text{Fe}(\text{CO})_5$. Apparently, Fe formed on $\text{Fe}(\text{CO})_5$.

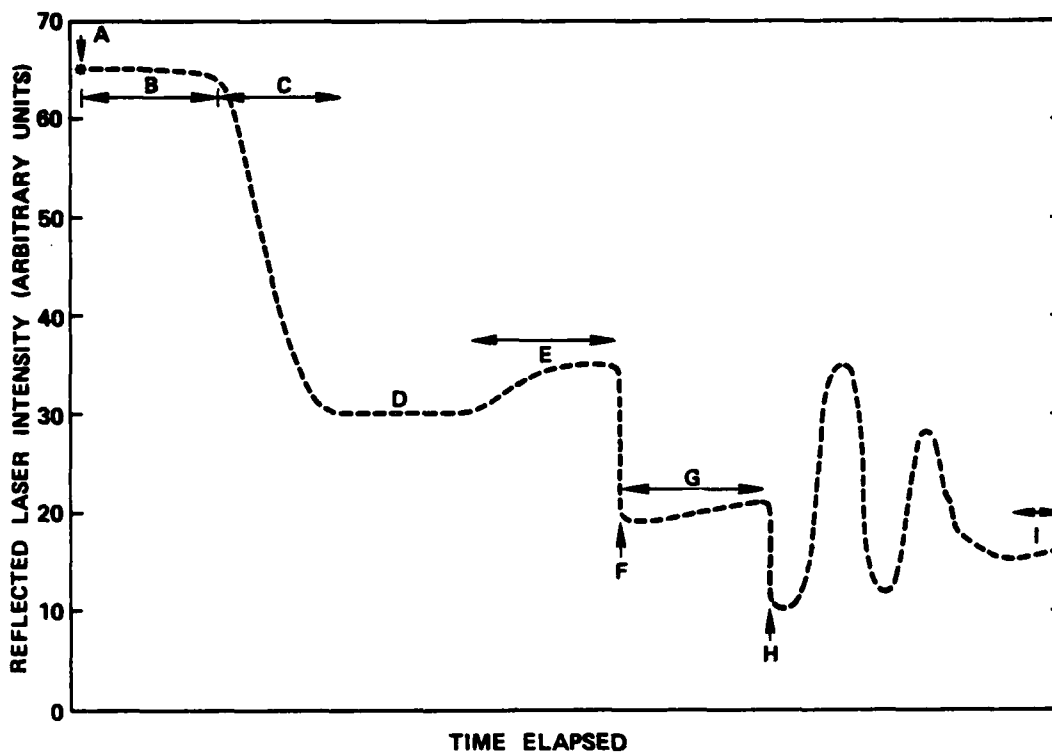

FIGURE 18. Reflected He-Ne Laser Beam Intensity During Adsorption and Photolysis of $\text{Fe}(\text{CO})_5$ on GaAs. Following procedures apply: A, chamber evacuated, sample at 300 K; B, introduction of $\text{Fe}(\text{CO})_5$ at 0.4 torr; C, sample being cooled; D, sample at 77 K, E, UV exposure for 55 sec; F, introduction of $\text{Fe}(\text{CO})_5$ at 0.4 torr; G, UV exposure for 8 min; H, introduction of $\text{Fe}(\text{CO})_5$ at 0.4 torr; I, UV exposure for 5 min.

As the trapped $\text{Fe}(\text{CO})_5$ attempted to disperse at higher temperature, ruptures formed and the Fe film ultimately floated down to the GaAs surface. The observed coloration effects were apparently due to interference effects associated with the thick $\text{Fe}(\text{CO})_5$ and the etalon-like Fe films sandwiched between.

Figure 21 shows the calculated reflectance of Fe on GaAs as a function of Fe thickness at two wavelengths. Figure 22 shows the calculated reflectance of Fe of various thicknesses as a function of wavelength. We can conclude from these calculations that a significant thickness of Fe (at least 10 to 20 monolayers) is necessary to observe any noticeable change in reflectance using the laser monitor.

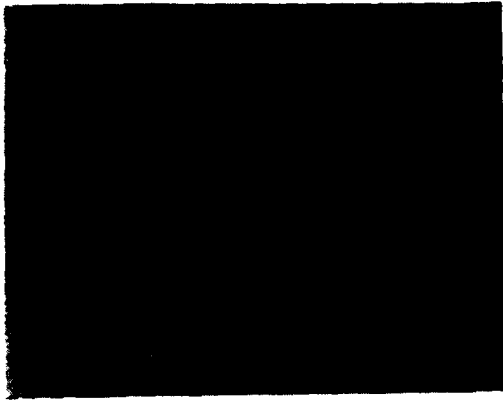

FIGURE 19. Ruptured Deposits on (100) GaAs From UV Photolysis of $\text{Fe}(\text{CO})_5$ Adsorbed on GaAs at Liquid N_2 Temperature. Magnification 800 on Nomarski microscope.

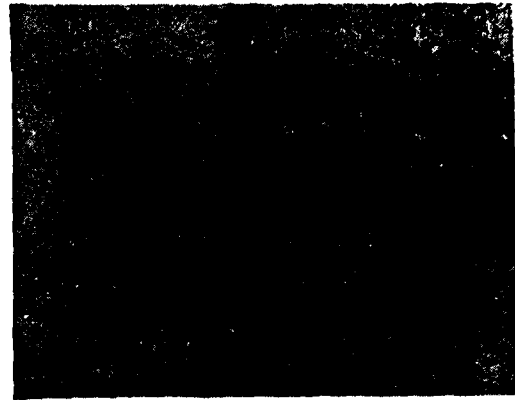

FIGURE 20. Ruptured Deposits on (100) GaAs From UV Photolysis of $\text{Fe}(\text{CO})_5$ Adsorbed on GaAs at Liquid N_2 Temperature. Demarcation boundary present. Magnification 800 on Nomarski microscope.

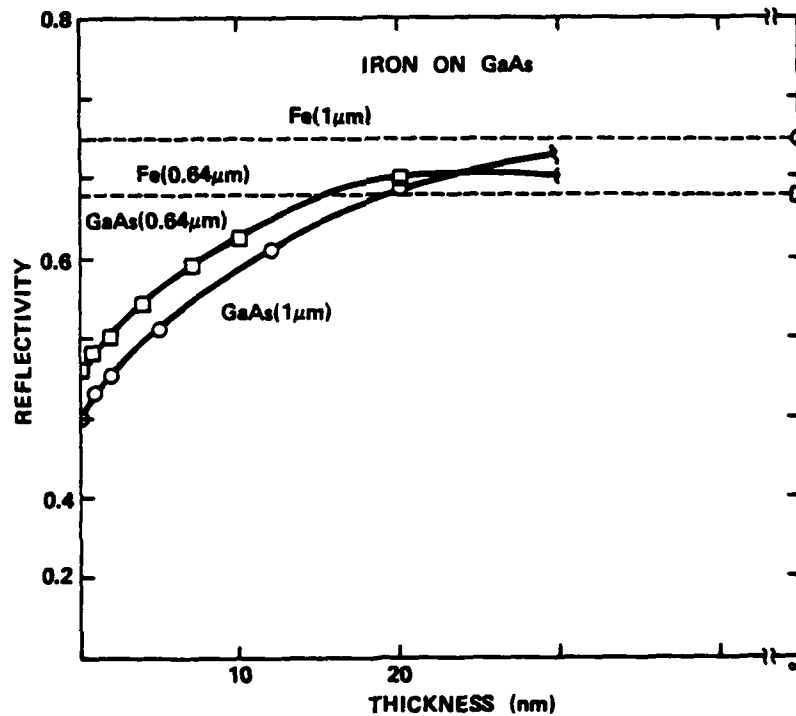

FIGURE 21. Calculated Reflectivities of Fe Film on GaAs as a Function of Fe Film Thickness at 0.64 and 1 μm Wavelength. Dashed lines indicate reflectivity of bulk Fe at the two wavelengths.

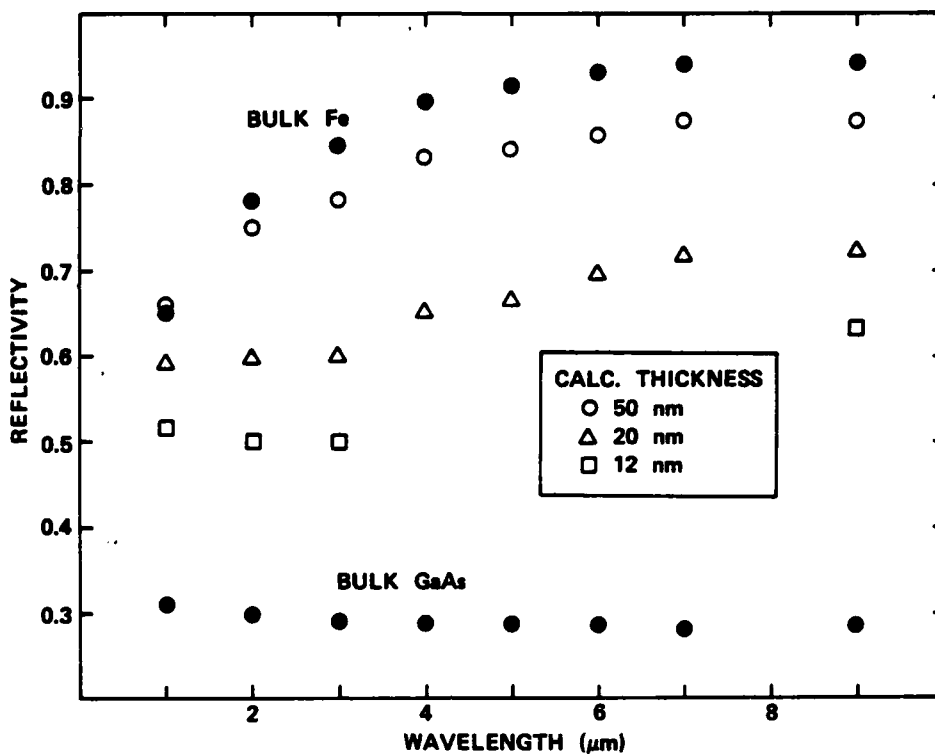

FIGURE 22. Calculated Reflectivity of Fe on GaAs as a Function of Wavelength for Various Fe Film Thicknesses. The bulk values for Fe and GaAs are shown with solid dots.

RECOMMENDATIONS

Based on the studies and experiments in photolyzing $\text{Fe}(\text{CO})_5$, the following recommendations are made for future work in this area.

(1) It would be highly desirable to incorporate a compound target molecule such as ZnSe or TiO_2 into the host organic species. This would allow direct deposition of the target molecule in a single decomposition step. Such an approach would allow better control in maintaining the stoichiometry of the species to be deposited. Such a deposition technique, when combined with UV photolysis of the OM decomposition, may lead to lower temperature metallization and passivation of temperature-sensitive semiconductors such as HgCdTe .

(2) Investigate the use of higher energy photons to dissociate completely the OM molecule in a single step. Synchrotron radiation studies would be highly desirable.

(3) Pursue further the generation of UV light within the deposition chamber. This becomes very important in flow experiments where a large deposition rate is the goal.

(4) Determine the limits imposed by the thickness of the adsorbed OM film on the UV photolysis process.

(5) Grow submonolayers of metals controllably. Perform submonolayer physics experiments.

Appendixes E and F describe in detail further outcomes of this ten-week period. Appendix E gives an account of a patent disclosure; Appendix F reports a visit to Rockwell International, where similar work is being undertaken.

Appendix A

TOXICITY OF PENTACARBONYL-IRON

Following is an excerpt taken from the work of V. L. Volkov and others,¹¹ which has been translated from Russian by P. Walsh, Fairleigh Dickinson University (one of the authors of this report).

"Iron carbonyl obtained by synthesis is an extremely strong poison through its activity on the central nervous system of humans and animals, on their breathing organs, and mucous membranes. When breathing its vapors, iron carbonyl produces headache, dizziness, nausea, vomiting, and, in extreme cases, the loss of consciousness. Penetrating through the tissues of the lungs into the blood, the undecomposed portion of the vapors of pentacarbonyl-iron ($\text{Fe}(\text{CO})_5$) produces irreversible destruction to the tissues and liver. Upon strong exposure, $\text{Fe}(\text{CO})_5$ provokes swelling of the lungs which develops as a result of the interaction of the excessively active carbon monoxide, which has been liberated within the hemoglobin of the blood in the form of carbo-oxide-hemoglobin. In addition, the vapor of $\text{Fe}(\text{CO})_5$ spontaneously attacks the lung tissues.

"Careless handling of $\text{Fe}(\text{CO})_5$ can lead to fatal poisoning. In the opinion of a series of scholars, the toxic action of $\text{Fe}(\text{CO})_5$ on the human organism is very similar to the activity of cancer-producing nickel tetracarbonyl, for which the Moscow Institute of Hygiene of Cabor ... has recommended a permissible standard limit of 0.00001 mg/l. As an example, after the investigation of the carbonyl combination of metals, the explanation of the toxic activity which is associated with nickel carbonyl can serve with several modifications for the description of the physiological effects of $\text{Fe}(\text{CO})_5$. The physiological action of $\text{Fe}(\text{CO})_5$ on the human organism is more complex than the influence of pure carbon monoxide."

Appendix B

MONOLAYER FORMATION RATE FOR AN ADSORBED SPECIES
AS A FUNCTION OF PRESSURE

From kinetic theory of ideal gas, the rate at which molecules strike a surface is

$$J = \frac{1}{4} n \langle v \rangle ,$$

where $n = M/V$ is the gas density and $\langle v \rangle$ is the average velocity of the molecule.

Since the average kinetic energy of the molecule is $m \langle v \rangle^2 / 2$, it follows that

$$\langle v \rangle = \left(\frac{3kT}{m} \right)^{1/2} .$$

Thus, for $\text{Fe}(\text{CO})_5$, $m = 196 m_p$ (m_p is the proton mass)

$$\langle v \rangle = 1.95 \times 10^4 \text{ cm/sec} .$$

At room temperature for $\text{Fe}(\text{CO})_5$,

$$J = 1.56 \times 10^{20} P \text{ (torr)} \text{ cm}^{-2} \text{ sec}^{-1} .$$

Since the cross-sectional area of $\text{Fe}(\text{CO})_5$ is about $(5.5 \text{ \AA})^2 = 30 \text{ \AA}^2 = 3 \times 10^{15} \text{ cm}^2$, the number of $\text{Fe}(\text{CO})_5$ molecules covering a unit area to one monolayer is

$$\frac{1}{3 \times 10^{15}} = 3.33 \times 10^{14} .$$

If we assume a unity sticking coefficient on the sample, the number of $\text{Fe}(\text{CO})_5$ monolayers forming on the sample per second is just

$$\frac{1.56 \times 10^{20} P \text{ (torr)}}{3.33 \times 10^{14}} = 4.68 \times 10^5 P \text{ (torr)} \text{ sec}^{-1}$$

and the number of angstroms per second is

$$2.57 \times 10^6 P \text{ (torr)} \text{ \AA/sec} .$$

The above assumes that we have an unlimited supply of $\text{Fe}(\text{CO})_5$. From the foregoing, we see that $\text{Fe}(\text{CO})_5$ deposits quite rapidly on cold surfaces.

Appendix C

UV FLUX REQUIRED FOR PHOTODISSOCIATION OF A $\text{Fe}(\text{CO})_5$
FILM OF GIVEN THICKNESS

Definition of terms:

- N = number of photons falling on the sample of area A per second, in centimeters squared (cm^2)
 W = UV flux from a cylindrical lamp of length L , in watts (W)
 A = sample area, in cm^2
 V^* = photon energy of the UV light, in electron volts (eV)
 R = distance of the sample from the axis of the lamp, in cm
 L = length of the cylindrical UV source, in cm
 T = fractional transmittance of the film to UV light
 M = number of molecules of $\text{Fe}(\text{CO})_5$
 η = fraction of M adsorbed on the sample
 λ = film thickness
 P = pressure, in torr

Photon flux from the lamp is W/eV .
 Photon flux on the sample is

$$N = \frac{W}{eV^*} \left(\frac{A}{2\pi RL} \right) .$$

For a low-pressure Hg lamp, $V^* = 5 \text{ V}$. This is the 2537 \AA line which is mostly absorbed by $\text{Fe}(\text{CO})_5$. Thus,

$$N = 1.25 \times 10^{18} W \left(\frac{A}{2\pi RL} \right) \text{ photons/sec} .$$

Assume ηM to be the amount of $\text{Fe}(\text{CO})_5$ adsorbed onto the sample. Then $\eta M/\lambda A$ is the molecular density of the adsorbed film.

The fraction of the UV light transmitted through this film will be

$$T = \exp(-Q \eta M/\lambda A) ,$$

where Q is the absorption cross section of the film (cm^2).

Since the cross-sectional area of an Fe molecule is about 6 \AA^2 , or $6 \times 10^{-16} \text{ cm}^2$, it follows that the number of Fe molecules required to cover an area A to one monolayer is

$$A/6 \times 10^{-16} = 1.66 \times 10^{15} A .$$

Assuming that we require five photons to liberate one Fe, it follows that the time needed to dissociate $\text{Fe}(\text{CO})_5$ and to form one monolayer of Fe on a substrate is

$$\frac{1.66 \times 10^{15} \text{ A}}{\text{TN}/5} = 6.666 \times 10^{-3} (2\pi\text{RL}/\text{W}) \exp(\text{Q } \eta\text{M}/\text{A}) .$$

From Reference 25, $\text{Q} = 1 \times 10^{-17}$ for $\text{Fe}(\text{CO})_5$, and substituting for M from Appendix D, the above relation becomes

$$6.66 \times 10^{-3} (2\pi\text{RL}/\text{W}) \exp(3.2 \times 10^{-1} \eta\text{PV}/\text{A}) \text{ sec} ,$$

For example, for typical values in our experiment, $\text{W} = 1 \text{ W}$, $\eta = 7.4 \times 10^{-3}$, $\text{A} = 1 \text{ cm}^2$, $\text{V} = 314 \text{ cm}^3$, $\text{R} = \text{L} = 10 \text{ cm}$. Table C-1 shows expected film thicknesses, λ , and dissociation times of $\text{Fe}(\text{CO})_5$.

TABLE C-1. Tabulation of Expected $\text{Fe}(\text{CO})_5$
Film Thicknesses and Dissociation Times.

P, torr	λ , Å	time, sec
0.1	165	4.5
0.5	825	6.1
1.0	1650	8.8
5.0	8250	172.0
10.0	16,500	∞

Appendix D

MONOLAYERS OF $\text{Fe}(\text{CO})_5$ FORMED ON A SUBSTRATE FOR A
GIVEN PRESSURE AND VOLUME OF $\text{Fe}(\text{CO})_5$

From the ideal gas law,

$$PV = MkT \quad ,$$

where P, V, M, k, and T are pressure, volume, number of molecules, Boltzman constant, and temperature, respectively.

The number of molecules per unit volume at room temperature is

$$3.2 \times 10^{16} P \text{ (torr)} \quad .$$

If this number is adsorbed uniformly and completely onto a mount structure of area A, the thickness, ℓ , of the film deposited will be

$$\ell = M\Omega/A \quad ,$$

where Ω is the molecular volume of the species.

For $\text{Fe}(\text{CO})_5$, which has a density of 1.47 gm/cm^3 and a molecular weight of 196,

$$\begin{aligned} \Omega &= 196 \times 1.67 \times 10^{-24} \text{ gm} / 1.47 \text{ gm/cm}^3 = \\ &2.22 \times 10^{-22} \text{ cm}^3 \text{ or } 222 \text{ \AA}^3 \quad . \end{aligned}$$

Thus, at room temperature, the film thickness on a cold finger will be

$$\ell \text{ (\AA)} = 710 P \text{ (torr)} V \text{ (cm}^3\text{)} / A \text{ (cm}^2\text{)} \quad .$$

Since one monolayer of $\text{Fe}(\text{CO})_5$ is about 5.5 \AA , the number of $\text{Fe}(\text{CO})_5$ monolayers formed will be $129 PV/A$.

NWC TP 6323

Appendix E

PATENT DISCLOSURE FOR THE UV PHOTOLYSIS OF COMPOUNDS TO
PRODUCE PURE FILMS WITH CONTROLLED GROWTH PROPERTIES

Disclosure for the Ultraviolet Photolysis of Compounds to
Produce Pure Films With Controlled Growth Properties

P. Walsh and N. Bottka

An important technique for the controlled deposition of thin films of metal, semiconductors, or insulators is the decomposition of compounds containing the desired molecule of the metal, semiconductor, or insulator at or near a suitable substrate in a controlled atmosphere. Examples of the desired target molecule are Ag, ZnS, and TiO_2 for a metal, semiconductor, or insulator, respectively. The compounds containing the molecule should be relatively stable so they can be handled easily. Inorganic compounds containing the desired molecule have often been used as the deposition vehicle. It is desirable to have the compound in the vapor or gaseous phase so that it can be manipulated easily within pressure, flow, or vacuum systems. Related deposition techniques include sputtering, evaporation, molecular beam deposition, and chemical vapor deposition (CVD). CVD involves a chemical reaction among gases to initiate decomposition. Pyrolysis is also a common decomposition technique in which high temperature is used to liberate the target molecule. All of the common techniques mentioned - sputtering, evaporation, molecular beam deposition, CVD, and pyrolysis - require or produce high temperatures in their application. The high temperature, unfortunately, produces outgassing of stray and unwanted gases from the walls and components of the deposition chamber and outdiffusion of chemical species from the substrate, and these gases can contaminate the deposited film.

The decomposition of the molecule-containing compound can, alternatively, be accomplished by photolysis using light. Photolysis can be carried out at low temperatures and thus offers a unique technique for depositing extremely clean films of the desired molecule on a given substrate. For rapid production of large-area thin films by photolysis, it is desirable that the molecule-containing compound flow past the substrate to be coated.

However, for precisely controlled buildup of, say, an epitaxial film, the film may be deposited by photolysis of a sequence of thin films of the compound (one to several monolayers thick) which have been adsorbed on the substrate. The substrate may be cooled, if necessary; exposure of the substrate to the compound gas or vapor is allowed; the compound is pumped out of the chamber; and the photolysis of the adsorbed compound is carried out. This produces a very thin layer of the molecule, perhaps less than 1-monolayer thick since the molecule is smaller than the compound containing it. The repeated cyclic reintroduction of the compound gas or vapor into the chamber - its adsorption and photolysis - allows the buildup of molecular film to a desired thickness.

The photolysis is commonly accomplished by irradiating the compound with light of sufficient energy to break apart the stable bonds attaching the molecule to the compound. This normally demands ultraviolet (UV) light; in compounds containing several bonds to the desired molecule, there is a reasonable assumption that very high energy, vacuum UV light will be required. This vacuum UV light will not pass through commonly available window materials, nor through the ambient atmosphere. Rather, an evacuated path must be used to transmit the highest energy UV region which is of interest here. Even if the UV were transmitted through a special window material, deposition of the decomposed compound gas or vapor within the chamber will rapidly coat the window material, preventing subsequent passage of the UV.

This note discloses a method for the photolysis of flowing or cyclically deposited compounds which contain a desirable molecule to be deposited. This method is achieved by the noncontaminating internal production of substantial quantities of very high energy UV light of various selected wavelengths within a cool low pressure system.

The internal production of high energy UV is accomplished by passing a discharge through a low pressure rare gas, often at pressures between several millitorr to several tens of millitorr of pressure. The rare gas may itself be buffered by another rare gas of higher ionization potential. The buffering rare gas may be present at pressures up to several torr or higher. The rare gases are extremely inert and produce minimal contamination of the film to be produced. The discharge current may often be tens of milliamps up to several amperes, depending on pressure, flow rate, and geometry without producing substantial temperature rise in the system. Direct current, alternating current, or high frequency excitation may be used.

Table 1 presents the ionization potentials, the excitation energy of the lowest strong resonant lines of the rare gases, and the corresponding wavelengths along with similar quantities for Hg, Cd, and TL, which are three common sources of external lower energy UV. The rare gas emits deep UV radiation whose energies range from 8.44 eV (xenon) to 21.1 eV (helium). This UV will not pass through common materials, as noted.

The rare gas or rare gas mixture may be introduced into the deposition chamber with the compound or separately from the compound. A system is illustrated schematically in Fig. 1 and in detail in Fig. 2. In Fig. 2, the rare gas or rare gas mixture streams in a region enclosing the compound flow tube. The compound flow tube will carry the compound, possibly diluted with the rare gas mixture, and is designed to flow lamnarily across the substrate. In the substrate region, perforations may be used in the flow tube to allow the deep UV from the

TABLE 1. Ionization Potential, Excitation Potential of the Singlet Level, P, and Corresponding Singlet Radiation Wavelength of Five Rare Gases. For comparison, similar quantities are given for three common external sources of lower energy UV.

Rare gas	Ionization potential, eV	Single excitation potential, eV	Wave-length, nm
He	24.6	21.1	58.4
Ne	21.6	16.8	73.6
Ar	15.8	11.8	104.9
Kr	14.0	10.0	116.5
Xe	12.12	8.44	129.6
Hg	10.4	6.70	184.9
Cd	9.0	5.29	228.8
TL	6.1	3.29	377.6

excited rare gas flowing outside the compound tube to penetrate into the compound region. The substrate may be placed on a demountable holder which may be either heated or cooled.

Figure 3 illustrates a cyclic deposition system. In all cases, the compound may be trapped in a cold trap or filter while the rare gas can be recycled. The cold trap must be sufficiently cold to condense the compound gas or vapor without condensing the rare gas used.

In one particular system, we have deposited an iron film by the UV photolysis of pentacarbonyl-iron ($\text{Fe}(\text{CO})_5$) with the 254 nm line of an external mercury lamp. Substrates were maintained at room temperature and also at dry ice-acetone temperature, -80°C .

The internally produced UV photolysis deposition method described above is particularly useful in the photodecomposition of organo-metal (OM) compounds. Some of these compounds, such as $(\text{CH}_3)_3\text{Al}$, $(\text{CH}_3)_3\text{Ga}$, $(\text{CH}_3)_2\text{Cd}$, are being used in OM-CVD systems to synthesize metals and semiconductors by pyrolysis. The admixture of the proper OM compounds in an internally produced photolysis OM-CVD reactor would allow the deposition of metals, semiconductors, or insulators at much lower temperature than possible with pyrolysis. Such low temperature deposition processes would be indispensable in the metallization and passivation of semiconductors such as HgCdTe , which decompose readily at moderate temperatures because of the high vapor pressure of their constituents. OM compounds containing column III-V or II-VI elements and oxide compounds (such as ZnS , ZnSe , HgS , SiO_2 , TiO_2) have been or

can be synthesized in the laboratory. Their use in the low temperature photolysis process would allow the synthesis of high- and low-index films of very high quality which is required for low absorption optical coatings.

Under proper substrate surface condition, such films would not only adhere better, but would grow epitaxially upon the substrate for use in active semiconductor devices. In the cyclic deposition method, the deposition rate would be very slow and controlled in a manner similar to that found in molecular beam epitaxy, with the advantage of much higher surface area homogeneity at a much lower cost.

The flow method would allow high growth rates over large substrate surface area.

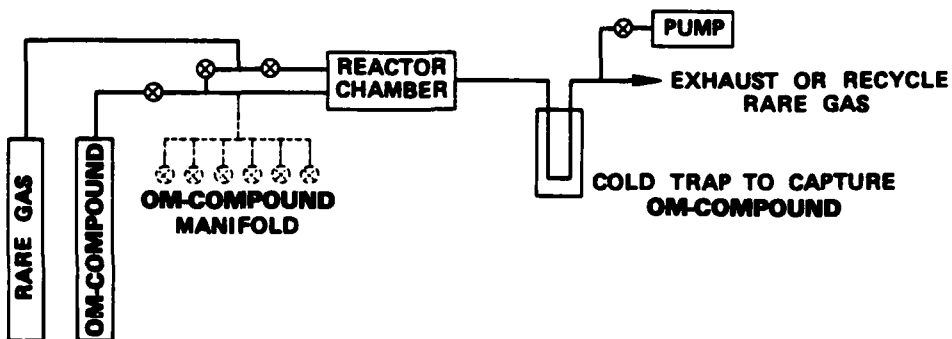

FIGURE 1. Flow System With Chamber.

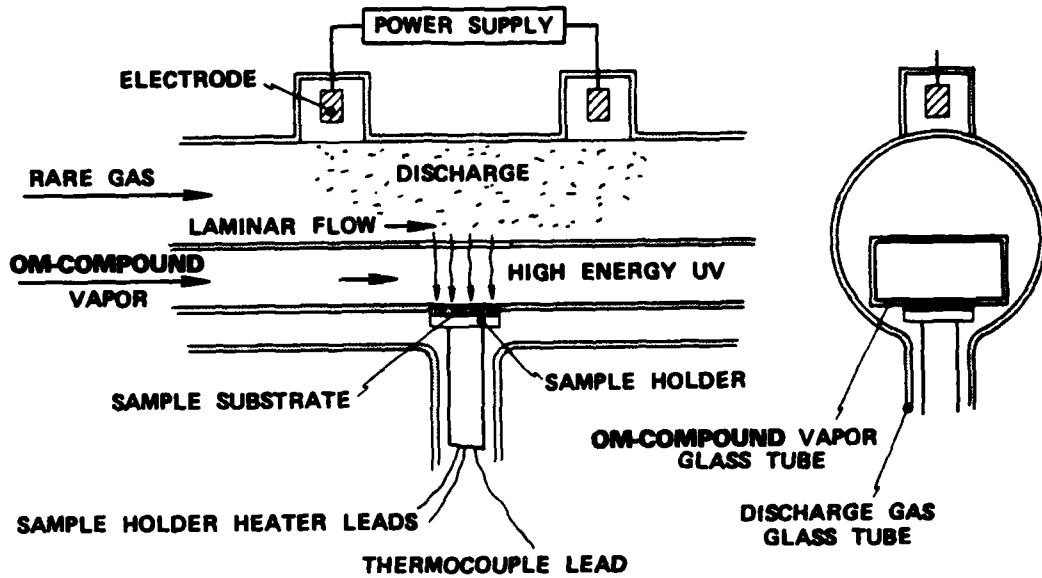

FIGURE 2. Flow System-Reactor Chamber Detail.

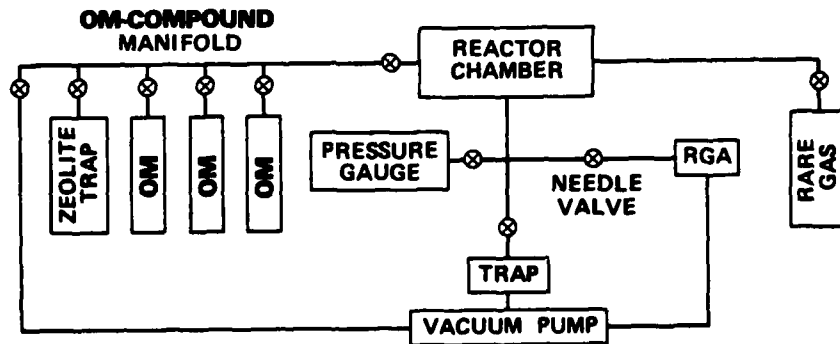

FIGURE 3. Cyclic Deposition Scheme.

NWC TP 6323

Appendix F

MEMORANDUM REPORTING VISIT TO ROCKWELL INTERNATIONAL,
METAL ORGANIC LABORATORY

NWC TP 6323



DEPARTMENT OF THE NAVY
NAVAL WEAPONS CENTER
CHINA LAKE, CALIFORNIA 93355

IN REPLY REFER TO
3813/PW/NB:sc
Reg 381-144
9 June 1981

MEMORANDUM

From: P. Walsh and N. Bottka, Code 3813
To: Head, Semiconductor & Surface Science Branch, Code 3813
Subj: Visit to Dr. H. Manasevit, Rockwell International, Metal Organic Laboratory, Anaheim, Calif., 5 June 1981

1. Prior to setting up an experimental system designed to study the photolytic deposition of metal and dielectric thin films, arrangements were made to visit Dr. Manasevit at his laboratory at Rockwell International. Dr. Manasevit is a pioneering authority on pyrolytic thin film deposition from organo-metal (OM) compounds. He has published extensively and has an international reputation. Dr. Manasevit took us through his research laboratory. He was very cordial and quite open in his advice to us. The following is a list of pertinent observations.

a. Dr. Manasevit believes that if the chemistry is correct, organo-metals chemical vapor deposition (OM-CVD) is a technique capable of quality superior to others.

b. A transparent reactor is desirable for research experiments so that the film deposition can be viewed.

c. Dr. Manasevit's reactor is demountable, with a viton ring used at the glass-to-glass joint. Heat provides problems with greased joint seals.

d. The remainder of the system should be all stainless steel. Dr. Manasevit foresees some problems with a Cu system.

e. Sapphire is a good all-purpose substrate for initial thin film deposition.

f. Dr. Manasevit uses stainless steel tanks, ~ 6 in. long, filled by the supplier to introduce the OM. Occasionally, Dr. Manasevit has fabricated his own tanks, but they are normally provided by the supplier.

g. The Alfa Products Division of Ventron Corp., Danvers, Mass., is the main vendor for OM's used by Dr. Manasevit.

h. On occasion, liquid has been noticed at the tank opening, so care should be exercised in handling the delivered OM tank.

i. The tank is checked for integrity by freezing in liquid N₂ and then pumping on a high vacuum system to see if the tank holds vacuum after the volatiles are pumped off. For tanks used as bubblers, care must be taken in evacuating the proper port so that the OM liquid is not drawn into the vacuum system.

j. Each OM has a separate feed line and flow meter.

k. The flow controller used for each OM is the flow controller on the flow meter.

Subj: Visit to Dr. H. Manasevit ... 5 June 1981

- l. Dr. Manasevit uses hydrogen as a carrier gas for his system.
- m. The hydrogen and the OM are burned off at the system exhaust.
- n. The entire system is constructed within an exhaust hood which apparently runs continuously.
- o. In many experiments, the runs are above atmospheric pressure, and the exhaust is open-vented through the burner.
- p. In low-pressure runs, the OM is cold trapped before the pump and is subsequently removed by heating the cold trap while back-flowing hydrogen through the burner.
- q. Runs are most successful if the OM flow is allowed to saturate all surfaces with OM before pyrolysis begins.
- r. The system is built in sections, each of which can be closed off separately to facilitate leak checking.
- s. Dr. Manasevit advises that the operator should consider, before he begins, the importance of turning the correct valve. Introduction of an OM into the wrong part of the system requires dismantling of that part and decontamination.
- t. Initial surface processing, e.g., heat, is required when the substrate is first used to break oxide bonds and to activate the surface for use with OM's.
- u. The stainless steel components are prepared by degreasing, acid cleaning, (and heating?) in the typical manner for high vacuum systems.
- v. Dr. Manasevit recalls that binary and ternary compounds, including Mg-Cd-Te, have been prepared using OM's.
- w. Battelle Northwest Laboratories, Richland, Wash., has done work with carbonyls.
- x. Dr. Manasevit suggests TMAL and TMGa as good starting materials for gaining experience with OM's.
- y. A chemist's advice is needed on any project with OM's to assure that the chemistry of a contemplated experiment is correct.
- z. Research on OM-CVD has been and is extensive in Europe. In particular, France is doing extensive research on the kinetics of surface chemistry using surface analytical techniques.
- aa. Dr. Manasevit has experienced few safety problems in his hooded, vacuum-tight, stainless steel, hydrogen-purged burner system in which the OM is introduced from a presealed stainless steel tank.

P. WALSH

N. BOTTKA

INITIAL DISTRIBUTION

- 3 Naval Air Systems Command
 - AIR-00D4 (2)
 - AIR-310B, J. Willis (1)
- 1 Chief of Naval Operations (OP-82F3)
- 1 Chief of Naval Material (MAT-08L)
- 3 Naval Sea Systems Command
 - SEA-034D, T. Tasaka (1)
 - SEA-99612 (2)
- 2 Chief of Naval Research, Arlington
 - ONR-200 (1)
 - ONR-421, G. Wright (1)
- 2 Naval Research Laboratory
 - Code 6820, Dr. H. Lessoff (1)
 - Electronic Technology Division, Magnetism Branch, Dr. G. Prinz (1)
- 1 Office of Naval Research Branch Office, Boston (Dr. Fred Quelle)
- 1 Office of Naval Research Branch Office, Pasadena (Dr. Robert R. Brandt)
- 2 Defense Technical Information Center

