

AD-A117 825

ITT ELECTRO-OPTICAL PRODUCTS DIV ROANOKE VA
OPTICAL ROTARY JOINT.(U)
JUN 82 R O MAY

F/6 20/6

UNCLASSIFIED

ITT-82-24-82

N00014-81-C-2625

NL

[REDACTED]

[REDACTED]

[REDACTED]

[REDACTED]

[REDACTED]

[REDACTED]

[REDACTED]

[REDACTED]

[REDACTED]

[REDACTED]

[REDACTED]

[REDACTED]

[REDACTED]

[REDACTED]

[REDACTED]

[REDACTED]

[REDACTED]

[REDACTED]

[REDACTED]

[REDACTED]

[REDACTED]

[REDACTED]

[REDACTED]

[REDACTED]

[REDACTED]

[REDACTED]

[REDACTED]

[REDACTED]

[REDACTED]

[REDACTED]

[REDACTED]

[REDACTED]

[REDACTED]

[REDACTED]

[REDACTED]

[REDACTED]

[REDACTED]

[REDACTED]

[REDACTED]

[REDACTED]

[REDACTED]

[REDACTED]

[REDACTED]

[REDACTED]

[REDACTED]

[REDACTED]

[REDACTED]

[REDACTED]

[REDACTED]

[REDACTED]

[REDACTED]

[REDACTED]

[REDACTED]

[REDACTED]

[REDACTED]

[REDACTED]

END
DATE
FILMED
BY
DTIC

12

AD A117025

DTIC FILE COPY

DTIC
ELECTE
JUL 19 1982

DISTRIBUTION STATEMENT A
Approved for public release;
Distribution Unlimited

ELECTRO-OPTICAL
PRODUCTS DIVISION

ITT

908

12

OPTICAL ROTARY JOINT

Final Report

Item A002

Contract N00014-81-C-2624

Prepared for:

Naval Research Laboratory
4555 Overlook Avenue, S.W.
Washington, D.C. 20375

DTIC
SELECTED
JUL 19 1982
S H

Prepared by:

ITT Electro-Optical Products Division
7635 Plantation Road, N.W.
Roanoke, Virginia 24019

Approved by:

Albert D. Bender
Albert D. Bender, Director,
Fiber Optic Systems

Date: June 18, 1982
Doc Id No: 82-24-02

DISTRIBUTION STATEMENT A
Approved for public release;
Distribution Unlimited

UNCLASSIFIED

SECURITY CLASSIFICATION OF THIS PAGE (When Data Entered)

REPORT DOCUMENTATION PAGE		READ INSTRUCTIONS BEFORE COMPLETING FORM
1. REPORT NUMBER	2. GOVT ACCESSION NO. AD-A117025	3. RECIPIENT'S CATALOG NUMBER
4. TITLE (and Subtitle) OPTICAL ROTARY JOINT		5. TYPE OF REPORT & PERIOD COVERED Final Report September 1981-May 1982
		6. PERFORMING ORG. REPORT NUMBER
7. AUTHOR(s) R. G. May, Jr.		8. CONTRACT OR GRANT NUMBER(s) N00014-81-C-2624
9. PERFORMING ORGANIZATION NAME AND ADDRESS ITT Electro-Optical Products Division 7635 Plantation Road, N.W. Roanoke, Virginia 24019		10. PROGRAM ELEMENT, PROJECT, TASK AREA & WORK UNIT NUMBERS
11. CONTROLLING OFFICE NAME AND ADDRESS Naval Research Laboratory 4555 Overlook Avenue, S.W. Washington, D.C. 20375		12. REPORT DATE June 18, 1982
		13. NUMBER OF PAGES
14. MONITORING AGENCY NAME & ADDRESS (if different from Controlling Office)		15. SECURITY CLASS. (of this report) Unclassified
		15a. DECLASSIFICATION/DOWNGRADING SCHEDULE
16. DISTRIBUTION STATEMENT (of this Report) <div style="border: 1px solid black; padding: 5px; width: fit-content; margin: 10px auto;"> <p style="text-align: center;">DISTRIBUTION STATEMENT A</p> <p style="text-align: center;">Approved for public release; Distribution Unlimited</p> </div>		
17. DISTRIBUTION STATEMENT (of the abstract entered in Block 20, if different from Report)		
18. SUPPLEMENTARY NOTES		
19. KEY WORDS (Continue on reverse side if necessary and identify by block number) Fiber optics Optical rotary joint		
20. ABSTRACT (Continue on reverse side if necessary and identify by block number) The primary objective of this contract is the design, fabrication, and testing of an optical rotary joint which permits transmission of signals through optical fibers across the interface of two environments rotating relative to each other. Outstanding optical performance is achieved through the use of gradient index lenses to couple radiation across the separation between two fibers. The salient features of this device are bidirectional operation at two wavelengths (850 nm and 1300 nm), low insertion loss, low rotationally induced variation of attenuation, a seven-circuit electrical slip-ring assembly, and rugged construction.		

DD FORM 1473

1 JAN 73

EDITION OF 1 NOV 68 IS OBSOLETE

UNCLASSIFIED

SECURITY CLASSIFICATION OF THIS PAGE (When Data Entered)

UNCLASSIFIED

SECURITY CLASSIFICATION OF THIS PAGE(When Data Entered)

20. (continued)

The device is designed to facilitate the application of future designs to pressurized, subsea environments.

Accession For	<input checked="" type="checkbox"/>
NTIS GRA&I	
DTIC TAB	
Unannounced	
Justification	<i>Per file</i>
<i>182 on file</i>	
By	
Distribution	
Availability Codes	
Dist	
A	



UNCLASSIFIED

SECURITY CLASSIFICATION OF THIS PAGE(When Data Entered)

TABLE OF CONTENTS

<u>PARAGRAPH</u>	<u>TITLE</u>	<u>PAGE</u>
1.0	INTRODUCTION	1
2.0	TECHNICAL SOLUTIONS	7
2.1	Mechanical Solutions	7
2.1.1	Lensed Ferrule Design	7
2.1.2	Slip-Ring Capsule Design	9
2.1.3	Optical-Mechanical Interface	10
2.2	Optical Solutions	15
2.2.1	Vignetting	20
2.2.2	Alignment Aperture	21
3.0	OPTICAL TERMINATION FABRICATION	25
3.1	Optical Prototype Fabrication	25
3.2	Optical Production	26
4.0	TESTING	30
4.1	Mechanical Tests	30
4.2	Optical Specifications	31
4.2.1	Cable Specifications	31
4.2.2	Optical Loss	31
4.2.3	Dispersion	33
4.2.4	Rotational Variation	35
4.2.5	Oscillatory Motion Test	35
4.2.6	Temperature Cycling Test	38
5.0	CONCLUSION	43

LIST OF ILLUSTRATIONS

<u>FIGURE</u>	<u>TITLE</u>	<u>PAGE</u>
1.0-1	Optical Rotary Joint Design Configuration	2
2.1.1-1	FOT Ferrule Assembly	8
2.1.3-1	Retainer Assembly	12
2.1.3-2	Strength Member Tie-Off Assembly	14
2.2-1	Selfoc [®] Lens Ray Trace	18
2.2.1-1	Vignetting Effect	22
2.2.2-1	Use of Aperture in Alignment	24
4.2.5-1	Oscillatory Motion Test at $\lambda = 1.3 \mu\text{m}$	39
4.2.5-2	Oscillatory Motion Test at $\lambda = 1.3 \mu\text{m}$	40
4.2.6-1	Temperature Cycling at $0.83 \mu\text{m}$	41
4.2.6-2	Temperature Cycling at $1.3 \mu\text{m}$	42

1.0 INTRODUCTION

This final report presents the results of work accomplished by ITT Electro-Optical Products Division (EOPD) under contract N00014-81-C-2624 for the Naval Research Laboratory (NRL). The goal of this contract was the design, fabrication, and testing of an optical rotary joint which permits the transmission of signals through optical fiber across the interface of two environments rotating relative to each other. The final design adopted imposes the restriction of a single optical circuit with the axis of the optical circuit coinciding with the cylindrical axis of the rotary joint and the axis of rotation. The final design configuration is illustrated in Figure 1.0-1.

The basis of the optical design is a pair of lensed ferrules. One lensed ferrule transforms the divergent output of the input fiber to the rotary joint into collimated radiation. The other lensed ferrule intercepts the collimated light which has transited the discontinuity between stator and rotor and reimages it onto the input end of the second fiber. Each lensed ferrule holds a Selfoc® gradient index (GRIN) lens of a quarter pitch length so that the output from the single optical fiber attached to the lens is refracted into a collimated, parallel output.

The intent of this contract has been to advance the state-of-the-art in single-fiber optical rotary joints; accordingly,

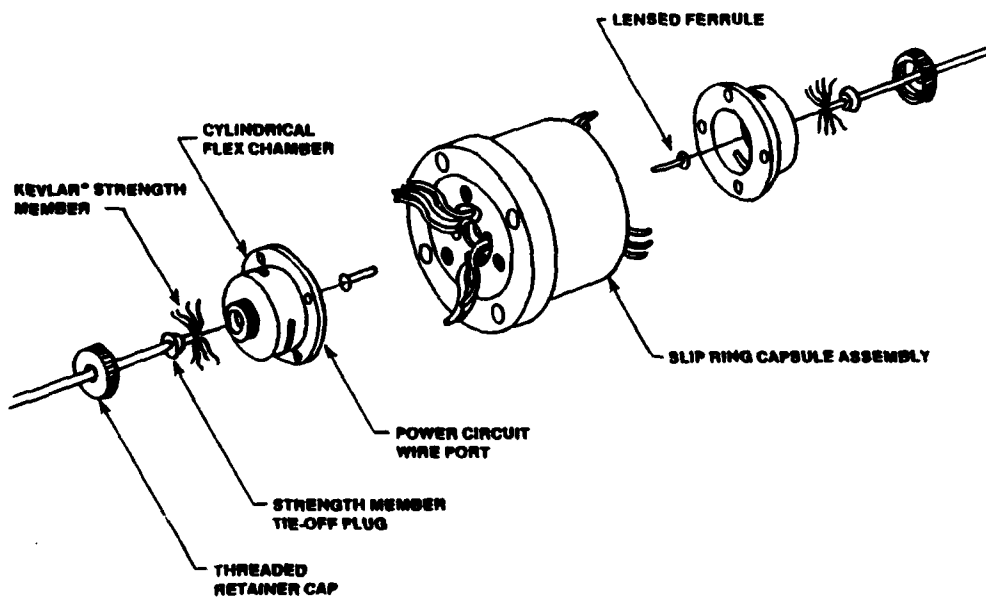

307 15704

Figure 1.0-1. Optical Rotary Joint Design Configuration.

1

most performance characteristics were adopted as goals rather than specifications. The features of this optical rotary joint that make it attractive for its intended application include:

- a. Bidirectional operation at two optical wavelength bands (800 nm to 900 nm and 1200 nm to 1350 nm) to increase transmission capacity by wavelength multiplexing
- b. Low insertion loss (between 1.0 dB and 1.5 dB for both wavelengths)
- c. Small variation of optical attenuation with rotational position
- d. Seven 10-A, 100-Vdc circuit electrical slip-ring assembly
- e. Use of seals to enable future use in subsea applications

Applications which require the passage of communications or command signals between two rotating reference planes abound in the military environment. Obvious examples include transmission of steering commands, telemetry, and target acquisition data across radar pedestals, gun mounts, or tank turrets. Transmittance of signals in an electrical circuit across a rotating interface is generally accomplished by drawing on the well established technology of the slip ring. In this device an electrical circuit is maintained between a rotor and a stator by a metallic brush in the stator that rides fixed, in constant contact, with a metallic plated ring in the rotor. However, sliding contacting parts imply wear, limited lifetimes, and susceptibility to wear-induced noise. At gigahertz frequencies, waveguide rotary joints may be

constructed so that sliding contacts are located at points of current minimums in the distribution of electromagnetic modes. When the wavelength of interest is shrunk to optical dimensions, it becomes possible, even preferable, to physically separate the two optical waveguides by using refractive optics to minimize the divergence of signal power across the separation gap.

The design described in this report was in response to a requirement for a fiber optic link between a submarine and a winch-deployable communications buoy. Two rotary joints capable of unidirectional propagation of light were necessary to complete the optical circuit from the cable on the rotating winch drum to the stationary submarine hull. Specification of unidirectional optical transmission in an inline coaxial configuration simplified the optical system design. A concentric electrical slip-ring assembly with seven circuits was desirable for passage of electrical power for various functions on the communications buoy. Communications capacity was to be enhanced by optically multiplexing two wavelength bands (800 nm to 900 nm and 1200 nm to 1350 nm) onto each fiber. Bandwidth requirements necessitated that pulse dispersion be less than 300 ps, and the link budget dictated that attenuation at either wavelength be less than 4.5 dB. In addition, the intended subsea application required submersible operation at up to 20.7 MPa pressure. Goals for performance under shock, vibration, and temperature extremes were modeled on standard military specifications.

ITT EOPD recognized that an elegant solution to this problem lay in an extension of technology it had developed in the application of GRIN lenses to fiber optic connectors. Use of GRIN lenses to expand and collimate the light passing between the connector halves allows the fiber ends to be more separated than is the case in a simple butt connection. It also reduces optical losses caused by infiltration of foreign objects between the connector halves, since with an expanded beam any dirt would block a smaller fraction of the total light transmitted. Use of collimating lenses reduces tight lateral and longitudinal machining tolerances but increases the need for stringent angular alignment which is more easily achieved with standard machining practices. For expertise in the design and fabrication of the mechanical assemblies, ITT EOPD turned to KDI Electro-Tec Corporation of Blacksburg, Virginia, which has paced developments in electrical slip-ring assemblies for over 30 years. Construction of a slip-ring capsule with precision sufficient to ensure proper optical alignment required no more machining accuracy than is currently standard engineering practice at Electro-Tec Corporation. By pooling the resources and expertise of two firms researching different technologies, the optical rotary joint constructed under this contract represents a further step in both disciplines.

The increasing use of optical fiber communications by military systems designers for its inherent high bandwidth, electromagnetic interference (emi) free operation, low weight, and low signal

attenuation will accelerate the development of high capacity, high performance optical rotary joints. It is the belief of ITT EOPD that the device developed under this contract represents the current state-of-the-art in optical rotary joints and a step in the continuing evolution of rotary joints with more capabilities.

Section 2.0 of this report describes the design solutions developed in response to the unique challenges posed by this contract. Efforts during the project fell naturally into two divisions, mechanical and optical, so this section is similarly divided. The subsection on mechanical solutions includes a discussion of the rationale behind the designs employed in the mechanical hardware. The subsection on optical solutions outlines the analytical work that preceded laboratory confirmation and also discusses the attempt to make low loss fiber-to-lens terminations. Section 3.0 reviews the actual fabrication of optical hardware and Section 4.0 explains the methodologies used in testing the assembled device, presents the data, and attempts an interpretation of that data. Section 5.0 presents a discussion of results and includes a brief summary of accomplishments.

2.0 TECHNICAL SOLUTIONS

The successful execution of this contract required the integration of solutions to a number of technical challenges. Key to this success was the realization that while the finished device represented a radical advancement in rotary joint state-of-the-art, advancement came by piecing together established technologies. Two broad headings for those technologies are optical technologies (fiber optics) and mechanical technologies (slip-rings). Accordingly, discussion of the technical design is divided along those lines.

2.1 Mechanical Solutions

The mechanical design of the optical rotary joint was approached with three main objectives in mind: provision for seven electrical circuits, ability to survive the required environmental tests, and mechanical precision sufficient to maintain proper optical alignment. This section describes the achievement of those objectives.

2.1.1 Lensed Ferrule Design

The seed used as a departure point for the mechanical design was the ferrule used to hold the lens-fiber assembly. During an internally funded ITT EOPD program researching lensed connectors, an ITT Cannon FOT fiber optic connector ferrule was found to be well suited for that application (see Figure 2.1.1-1).

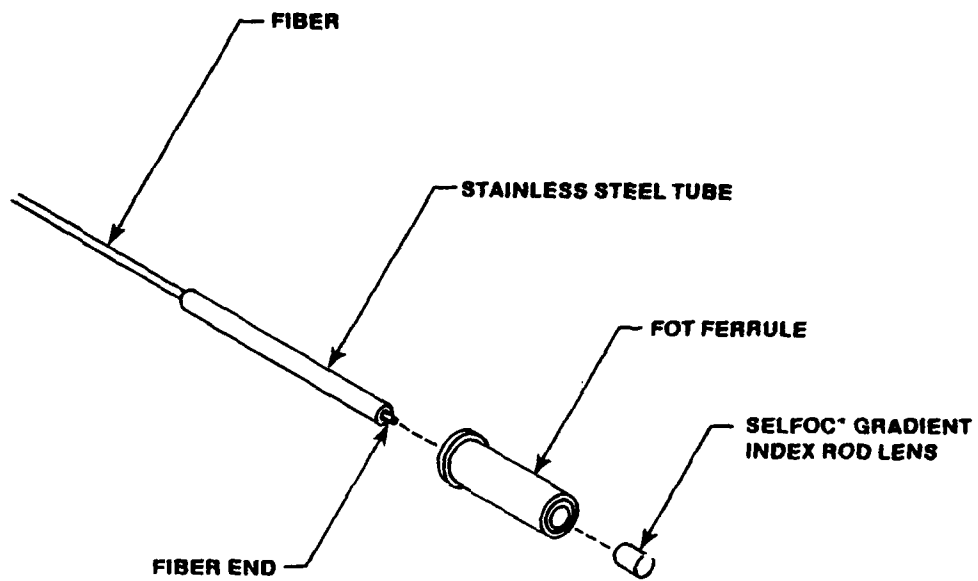

302 15783

Figure 2.1.1-1. FOT Ferrule Assembly.

22402

The ferrule end which normally possesses a watchmaker's jewel for fiber centering was drilled and reamed so that it would accept a 1-mm diameter Selfoc® rod lens. The fiber to be terminated was epoxied into a stainless steel tube for rigidity. Using a five-axis micropositioner (x, y, z, and θ , ϕ), the fiber was inserted into the FOT ferrule and the fiber end was brought in proximity to the lens. The relative alignment between fiber and lens was adjusted for an optimum as determined through a proprietary auto-collimation technique. At this point a heat curing optically transmissive epoxy was applied to the lens-fiber interface through an aperture that had been filed in the side of the FOT ferrule. Application of heat for epoxy curing completed the assembly.

2.1.2 Slip-Ring Capsule Design

During the preparation of a proposal for this contract it was recognized that the accuracies required in construction of the rotary joint mechanical assembly exceeded the present design and production capabilities of ITT EOPD. A manufacturer of custom electrical slip-ring capsules, Electro-Tec Corporation, was contracted by ITT EOPD to design and fabricate a slip-ring assembly that would satisfy not only ITT EOPD's specifications impacting optical performance but also contract requirements for environmental durability. The slip-ring capsule assembly designed and fabricated by Electro-Tec Corporation to house and align the lensed ferrules employed three precision high quality bearings to

maintain the stringent angular alignment of 0.2° . Most parts were typically machined with tolerances of 0.0002 in so that the total runout of the finished unit was less than 0.0005 in.

The Electro-Tec capsule included an electrical slip-ring assembly to provide seven 10-A, 100-Vdc power circuits. This assembly utilized gold plated brush wires riding in gold plated grooved rings. The use of gold plating anticipates the extension of future use to fluid-filled operation for pressurized subsea environments. A fluorosilicone seal was included to prevent infiltration of sea water through the separation between the stator and rotor. The optical rotary joint delivered to NRL at the conclusion of this contract is, however, not capable of submersible operation. This could be accomplished by merely sealing with epoxy the threaded retainer which holds the lensed ferrule in the slip-ring capsule. Operation under pressurized conditions at up to 20.7 MPa would necessitate a more extensive redesign. A fluid for internal pressure equalization which could remain stable over the pressure range of interest would first be identified. Application of pressure equalization bellows to slip-ring capsules is within the past experience of Electro-Tec engineers, and extension of those principles to the optical rotary joint should be straightforward.

2.1.3 Optical-Mechanical Interface

Well considered design of the interface between the optical

components and mechanical assemblies should enhance the usability of the device. In particular, the assembly to terminate the cable strength member should complete the environmental protection afforded by the capsule casing, and the components that retain the lensed ferrules should provide for serviceability.

It was recognized that testing of this first version of an optical rotary joint may require disassembly for troubleshooting so the FOT ferrule retainers were designed accordingly. Electro-Tec machined a clear axial bore in the slip-ring capsule providing for the FOT ferrules a clearance fit allowance of 0.0002 with a concentricity of +0.00005. A split brass collar was made to fit over the small stainless steel tube protruding from the end of the FOT ferrule, thereby protecting it. The slip-ring capsule was provided with a tapped hole at both ends of the bore so that a threaded brass retainer could be screwed over the split collar and lensed ferrule, securing them firmly in place (see Figure 2.1.3-1). Using this hardware, insertion and removal were both easy and repeatable.

It is obvious that a realistic mechanical design must isolate any tensile strain on the cable from the delicate optical components inside the rotary joint. The final design for the cable strength member tie-off was drawn from standard fiber optic connector designs. The optical fiber cable chosen for use in the

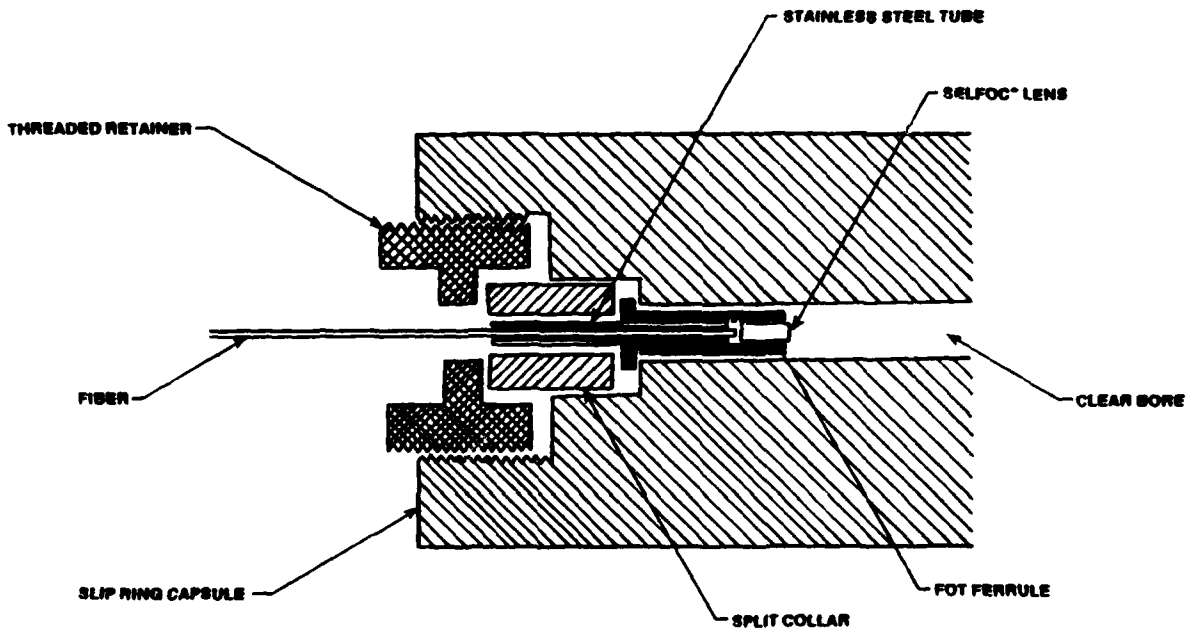

187 15786

Figure 2.1.3-1. Retainer Assembly.

1

fiber-to-lens termination was a single-fiber cable with a polyurethane overjacket and a Kevlar® aramid sheath for tensile strain protection. In making the terminations, the cable overjacket was stripped back so that approximately 4 in of fiber and 1 in of stranded Kevlar® lay exposed. A stainless steel cap was fabricated for the purpose of protecting and containing the fiber and terminating the Kevlar® strength member (see Figure 2.1.3-2). Termination of the Kevlar® was accomplished by clinching the Kevlar® between the cap and a conical chock held in place by a threaded nut. Nut, chock, and cap were all provided with a hole to allow for passage of the cable. The cap was built so that it provided an inner cavity that could serve as a flex chamber for the fiber. The 4 in of fiber between the strength member and the threaded retainer could thus be coiled in the chamber, isolating the terminals from any strain. This arrangement also aided in assembly by allowing the strength member tie-off and ferrule retainer to be installed before bolting the cap to the slip-ring capsule assembly.

Ease of assembly of this device was compromised by the presence of electrical circuit wires. The intended application of the optical rotary joint will ultimately employ a hybrid cable with both electrical conductors and an optical waveguide. In this case, all conductors and the optical fiber will pass through the same port in the cap, and electrical connections will be completed in the

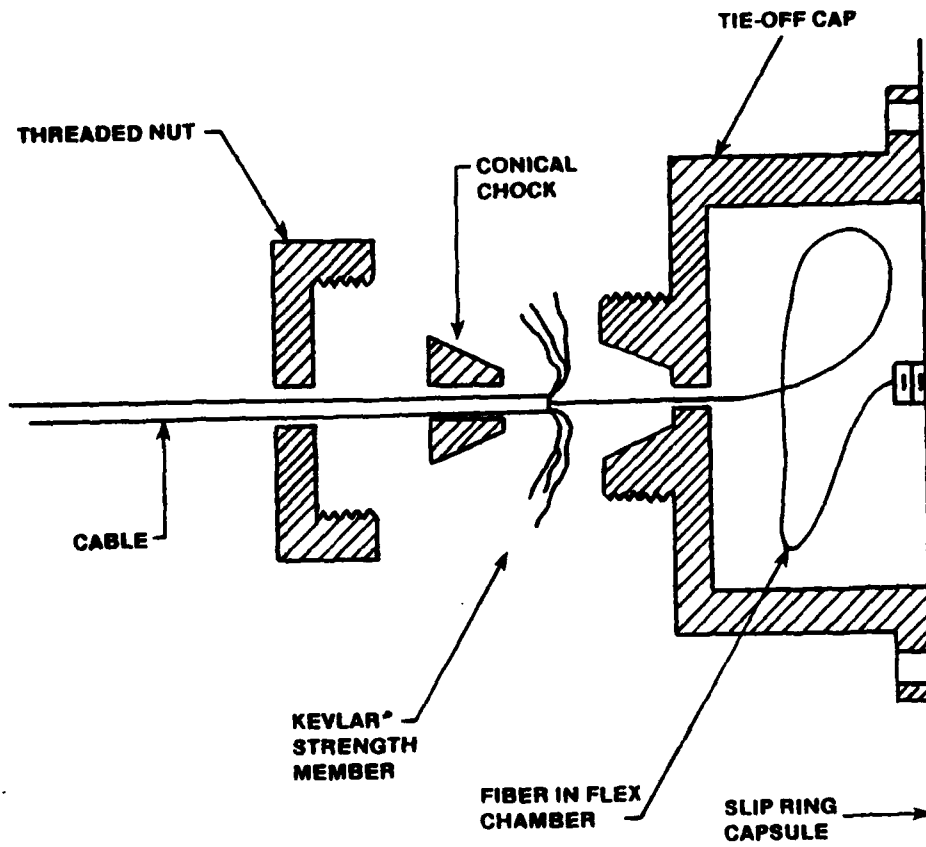

302 15780

Figure 2.1.3-2. Strength Member Tie-Off Assembly.

I

flex chamber. For the laboratory prototype produced under this contract, however, a single fiber cable was employed, so that a separate method of passing the electrical wires through the tie-off cap had to be found. A decision to use two small ports on the sides of the tie-off cap reduced the amount of wire in the flex chamber and minimized the interference of wire and optical cable. The radical bending of the wire conductors over such a small radius through the steel tie-off cap was made possible by the use of Tefzel® as a wire insulator. Tefzel® is not susceptible to cold-flow phenomena as are other insulators such as Teflon®, which would have risked the danger of short circuiting the conductors. Strain relief for the electrical conductors was integral with the capsule, but additional clamps for the wires were provided on the side of the tie-off cap.

The total volume of the completed rotary joint is 750 cm³. Although this is well within the 850 cm³ limit established by the contract, much of the volume is protective housing. Future refinements of this design could easily result in reductions in volume.

2.2 Optical Solutions

ITT EOPD's internal research and development (IR&D) program supporting the development of a fiber optic lensed connector provided a solid foundation of experience with which to begin this project.

In particular, it highlighted the appropriate questions to be addressed at the initiation of the program. The investigations that identified optical parameters impacting the final design are discussed in the following paragraphs.

The two main specifications of a fiber optic rotary joint affecting a communication system designer are insertion loss and dispersion. Both may be minimized by employing a simple butt connection employing as short a separation as possible. Unfortunately, any eccentricity greater than a few micrometers in the placement of a fiber end relative to the rotor or stator would lead to unacceptably large fluctuations in optical power throughput during rotation. Rather than accept the unreasonably tight machine tolerances that a butt connection would have necessitated, it was decided to use collimating lenses to reduce sensitivity to lateral alignment. Reduction of rotational variation due to eccentricity is more easily obtained by use of collimating lenses because the beam diameter is expanded to approximately 10 times the fiber diameter, making a misalignment of several micrometers insignificant compared to the beam diameter.

The lenses chosen for this project were Selfoc® 1-mm diameter gradient index lenses purchased from Nippon Sheet Glass (NSG), America. The lenses were cut for quarter pitch operation at 850 nm, which implies that radiation from an 850-nm point source placed at the plane of one end face of the rod lens would emerge

as collimated light output at the other end. If the point source is placed in the center of the circular end, the collimated output will be emitted parallel to the cylindrical axis of the lens. A transverse change in the position of the point source from the center of the input end will be translated to a change in the angle the collimated output makes with the axis of the lens. The inverse is also true; collimated light input into a GRIN lens will be focused to a point at the output end, and a change in the angle of the input light will shift the location of the point over the output end face (see Figure 2.2-1). The implication of this optical transformation is that just as losses due to divergence are an unavoidable consequence of a fiber-to-fiber butt joint, divergence of the collimated GRIN lens output is a necessary consequence of the finite size of the input fiber.

To quantify the divergence to be expected in use of the GRIN lenses, ITT EOPD turned to an analytical expression provided by NSG, America, in its Selfoc[®] lens applications notes.

The relation

$$\begin{bmatrix} x \\ \theta \end{bmatrix} = \begin{bmatrix} \cos \sqrt{A} z & \frac{1}{N_0 \sqrt{A}} \sin \sqrt{A} z \\ -N_0 \sqrt{A} \sin \sqrt{A} z & \cos \sqrt{A} z \end{bmatrix} \begin{bmatrix} x_0 \\ \theta_0 \end{bmatrix} \quad (2-1)$$

yields the angle and radial position θ , x of a ray exiting a

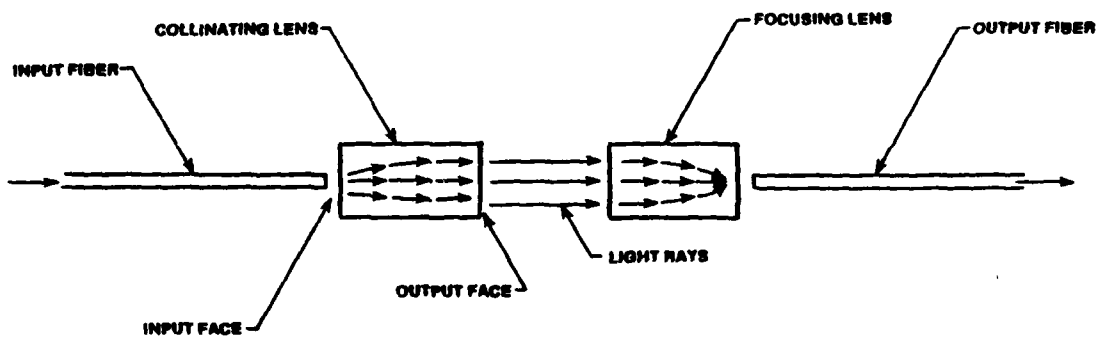

102 15785

Figure 2.2-1. Selfoc[®] Lens Ray Trace.

Selfoc® lens given the input angle and position θ_0 and x_0 of that ray. In the equations, z is the lens length, \sqrt{A} is a constant characterizing the lens's refractive index gradient, and N_0 is the refractive index at the lens axis. With a best case assumption of the fiber centered colinearly with the lens, x_0 would be a maximum of 0.025 mm for a 50- μ m core fiber. At this maximum radial displacement, the input angle would be zero due to the light propagation characteristics of graded-index fibers. Working this input condition through the transformation described yields a divergence of 1.4° due to the radial extent of the input fiber. Similarly, the size of the output beam at the output face of the lens can be shown to follow from the injection angle of the input light. In this case the input ray with the largest injection angle (with respect to the lens axis) will be found where the center of the fiber meets the GRIN lens. A graded-index fiber with a numerical aperture (NA) of 0.22 will input a ray at 12.7° at the center of the lens, assuming an air interface between fiber and lens, and assuming that the fiber is propagating the full modal volume that it is capable of sustaining. Using the same equations leads to the result that a fully injected fiber with a 0.22 NA should yield a 0.45-mm spot size or about 20% of the area of the lens face.

These predictions were confirmed experimentally by micropositioning a fully injected fiber to a Selfoc® lens and detecting the output with the charge injected diode (CID) array from a solid

state video camera. A proprietary circuit was used to convert the intensity distribution in one dimension on the array to an oscilloscope scan where amplitude varied according to intensity on the array. Calibration allowed for determination of the dimensions of the radiation pattern on the CID array from the oscilloscope sweep time. By placing the CID array target on an optical bench, the longitudinal separation of target and lens could be varied, and divergence could be calculated. In this way divergence was found to be 1.45° and the spot size 0.47 mm. The boundary for the spot size was chosen as that area where the light intensity had fallen to 10% of its peak value in the center of the spot. Both values are in close agreement with the analytically predicted values.

2.2.1 Vignetting

Another effect of interest in planning for termination of fiber to lens is the phenomenon of vignetting. If the angle of input radiation exceeds some critical angle, the output spot is translated sufficiently that its boundary exceeds (falls beyond) the periphery of the lens output face (see Figure 2.2.1-1). In that case the light at the extreme boundary of the spot furthest from the axis is refracted off the side of the lens. For the lens-fiber combination previously postulated, this would occur when the fiber axis makes an angle of 14° with the lens axis. This assumes an output spot size of 0.5 mm. The effect was confirmed in the laboratory by fixing a lens on a stationary mount and fixing a

fiber in a θ - ϕ gimbal so that the input angle could be varied. The fiber was injected with the output of an 850-nm light emitting diode (LED) through a mode scrambler constructed from a series of concatenated fibers of differing refractive index profiles. The use of the mode scrambler helped to ensure that the injection fiber was well filled modally. An image intensifier was used to observe the far-field intensity distribution on a wall as the input angle was varied. The vignetting effect was found to occur at about 15° .

2.2.2 Alignment Aperture

The use of an aperture positioned concentric with the output was considered to increase sensitivity of alignment to angular errors. The optics of the autocollimation technique used to align fiber to lens is such that the alignment is insensitive to angular misalignment of fiber to lens (which leads to a transverse shift in output beam) until a vignetting condition is achieved. If an aperture with a hole approximately the diameter of the spot size of the output beam is placed on axis next to the output lens face (see Figure 2.2.2-1), a shifted output beam will be partially blocked by the aperture boundary. The attendant reduction in output power would be indicative of angular misalignment.

An ITT Cannon FOT fiber optic connector ferrule was used to create an aperture. Since this type of ferrule was being used as the

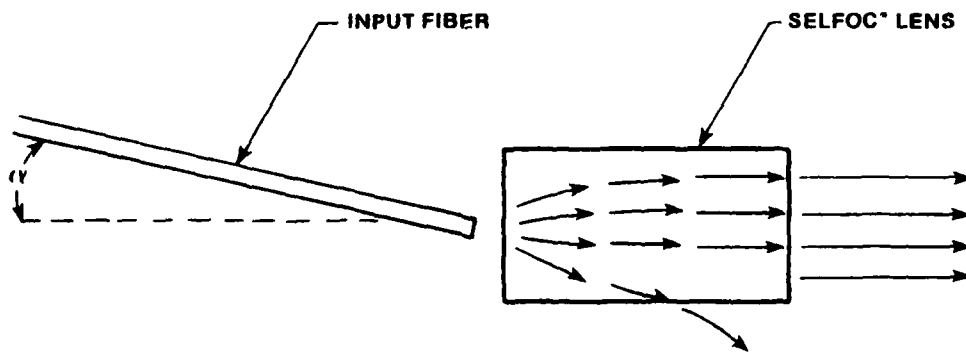

102 15781

Figure 2.2.1-1. Vignetting Effect.

housing for the Selfoc® lens-fiber termination, use of a similar ferrule with the same outside diameter (od) would facilitate colinear alignment of aperture and lens in a grooved slot. Eccentricity and concentricity tolerances for both ferrules and jewels ensured that alignment of ferrule exteriors would lead to centering of the lens axis and aperture center. After a geometric optics analysis determined the appropriate aperture dimensions for optimal sensitivity, a sapphire watchmaker's jewel having that aperture size was punched into the end of a ferrule.

During the construction of prototype terminations, conflicting results due to the aperture were obtained. It is now believed that the sapphire jewel, rather than being opaque to the 850-nm radiation, refracted the light, compounding the alignment problems. Further experimentation showed that by increasing the od of the stainless steel ferrule used to hold the fiber, the degree of angular freedom of the fiber inside the FOT ferrule could be reduced until the need for the aperture was eliminated.

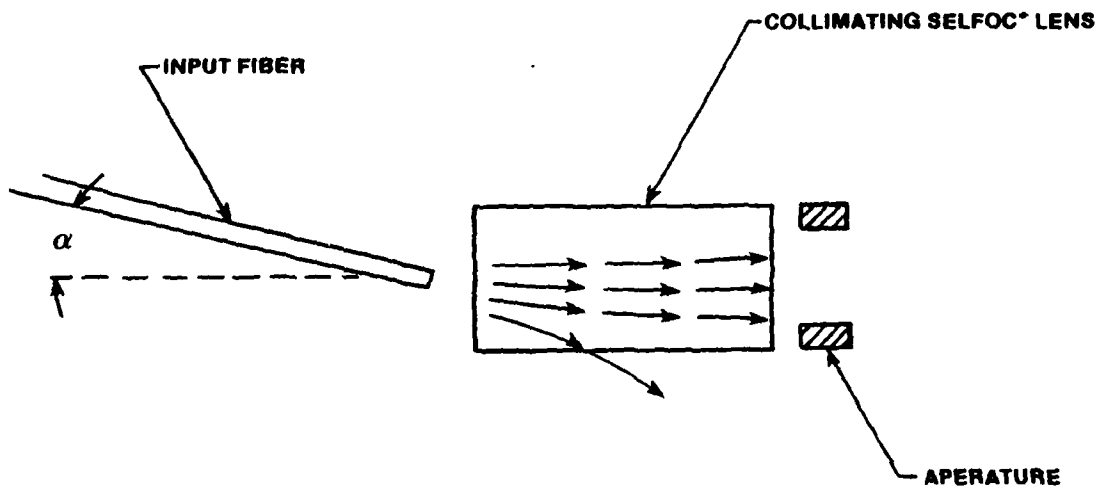

302 157R2

Figure 2.2.2-1. Use of Aperture in Alignment.

3.0 OPTICAL TERMINATION FABRICATION

Once constraints imposed by the mechanical design were understood and the expected optical performance had been characterized analytically, attempts were begun at making the fiber-to-lens terminations. The first seven attempts may be considered prototypes, as the assembly process was varied each time in an attempt to optimize that optical performance. An additional seven "production" terminations were then produced by employing the same assembly procedure throughout so that the best pair could be chosen for use in the final rotary joint. The fabrication attempts are described in this section.

3.1 Optical Prototype Fabrication

Engineering efforts during the reporting period concentrated on the production of two sets of lensed ferrule pairs suitable for inclusion in the two finished optical rotary joints. During prototype fabrication, seven terminations of fiber to lens were attempted to evaluate alignment techniques developed during the first half of the program. A number of variants of the termination procedures were tried to determine the optimal alignment sequence, including different techniques of epoxy application, different heat curing cycles, the use of ultraviolet (uv) curable optical adhesive, and the use of an aperture to increase sensitivity to angular misalignment. The Selfoc® lenses used for prototypes had lengths exceeding those necessary to perform

collimation at a wavelength of 0.83 μm (i.e., the focal points were located inside the glass rods). Use of an aperture between the Selfoc[®] lens output face and the autocollimation mirror was discontinued when it was discovered that it did not increase sensitivity. Insertion losses of different pairs of the seven prototypes measured at 0.83 μm yielded figures from 1.5 dB to 5.4 dB. Preliminary measurements of selected pairs were shown to suffer approximately 1 dB additional loss at the 1.3 μm wavelength over those measured at 0.83 μm .

3.2 Optical Production

After fabrication of the seven prototype terminations was completed, final construction of the production terminations to be used in the final assembly was begun. By the end of the reporting period, seven terminations were completed, using quarter pitch Selfoc[®] lenses certified by NSG, America, Inc., to have focal points placed outside the lenses by 0.050 mm to 0.150 mm. Different pairs of the seven production terminations chosen to represent all possible permutations were measured to have losses ranging from 0.9 dB to 2.9 dB at 0.83 μm . A matrix tabulating these insertion losses is presented in Table 3.2-1. Measurements were performed using a vee groove alignment fixture to allow positioning the pair of terminations coaxially at the 4 mm separation that would be present in the final assembly. The variation presented represents losses determined before and after one ferrule was

Table 3.2-1. Insertion Losses.

<u>Detector</u>	<u>Injector</u>						
	<u>P1</u>	<u>P2</u>	<u>P3</u>	<u>P4</u>	<u>P5</u>	<u>P6</u>	<u>P7</u>
P1		2.0	0.7	1.2	1.1	2.2	1.4
		(+0.1)	(+0.1)	(+0)	(+0.4)	(+0.3)	(+0.3)
		2.3	1.0	1.4	1.2	2.3	1.2
		(+0.3)	(+0.2)	(+0)	(+0.2)	(+0.3)	(+0.2)
P2	2.3		1.6	1.7	1.7	1.7	1.8
	(+0.4)		(+0.1)	(+0)	(+0.2)	(+0.4)	(+0.4)
	2.1		1.3	1.5	1.6	1.6	1.8
	(+0.1)		(+0.2)	(+0)	(+0.2)	(+0.2)	(+0.6)
P3	1.1	1.5		1.7	1.0	1.4	1.9
	(+0.1)	(+0.2)		(+0.2)	(+0.1)	(+0.2)	(+0.2)
	0.9	1.5		1.4	1.1	1.6	1.8
	(+0.2)	(+0.2)		(+0.2)	(+0)	(+0.1)	(+0.2)
P4	1.0	1.3	2.7		1.6	2.4	1.5
	(+0.3)	(+0.2)	(+0.3)		(+0.2)	(+0.3)	(+0.5)
	0.9	1.4	2.2		1.6	2.6	1.5
	(+0.3)	(+0.1)	(+0.1)		(+0.2)	(+0.3)	(+0.4)
P5	1.5	2.4	1.2	1.3		3.1	2.8
	(+0.2)	(+0.5)	(+0.3)	(+0.1)		(+0.3)	(+0.5)
	1.3	2.3	1.2	1.3		3.0	3.0
	(+0.4)	(+0.5)	(+0.2)	(+0.4)		(+0.6)	(+0.4)
P6	1.8	1.8	1.8	0.9	3.4		2.2
	(+0.2)	(+0)	(+0.1)	(+0.5)	(+0.3)		(+0.2)
	1.7	1.7	1.4	1.1	3.7		2.1
	(+0)	(+0.2)	(+0.2)	(+0.2)	(+0.4)		(+0.5)
P7	1.7	1.3	1.4	1.2	1.3	1.4	
	(+0.4)	(+0.1)	(+0.2)	(+0.2)	(+0.5)	(+0.2)	
	2.0	1.6	1.0	1.0	1.2	1.5	
	(+0.3)	(+0.1)	(+0.4)	(+0.3)	(+0.4)	(+0.2)	

Note: Upper reading is measurement at 1.3 μ m. Lower reading is measurement at 0.83 μ m. Reading in parentheses is variation. All readings in decibels.

rotated 90° about its cylindrical axis. These measurements were not intended to be a final absolute measure of optical performance but were intended to be an indication of relative merit of the different pairs from which the pairs for final assembly could be chosen.

However, an intermittent problem was encountered during construction of these production terminations. While the optically transmissive two-part epoxy used to pot the fiber in the ferrule holding the lens was cured by exposure to heat, the fiber was found to drift away from its optimal alignment. Upon evaluation of the terminations using the autocollimation technique, the drift was found responsible for an additional 0.5 dB to 1.75 dB loss. Optically, the effect of this drift was to cause an angular deviation of the collimated output from the ideal output colinear with the axis of the lens. This was confirmed experimentally by measuring far-field outputs using an image converter. At the same time, divergence of the output was measured. The mean angular deviation for the seven production terminations was 0.41° with a standard deviation of 0.14°, and mean divergence was found to be 1.43° with a standard deviation of 0.04°. Divergence at 0.83 μm was analytically predicted to be 1.4° and is a consequence of the finite size of the fiber core.

I

It is felt that the shorter Selfoc® lenses used in production ferrule fabrication may have been responsible for the drift, which was also present during prototype fabrication but not with the severity experienced while making the production terminations. Since the focal points of the lenses used for prototypes were inside the lenses, it was necessary to butt the fiber end face against the lens end face to achieve optimal performance. It is now suspected that friction between the two surfaces may have inhibited movement even in the presence of external forces. The external forces may be accounted for by differential expansion of curing epoxy due to nonuniform application of heat or by different rates of expansion of the metal fixtures holding fibers and ferrules. This latter hypothesis is supported by evidence that drift in all cases was found to be in the same direction. Elimination of this source of drift could perhaps have been obtained by a redesign of the alignment apparatus, which was prohibitively expensive.

4.0 TESTING

After assembly of the optical rotary joint was completed, the finished device was submitted to several tests to measure how well contract requirements had been achieved. Those mechanical specifications that were adopted as contract goals rather than contract requirements were not tested. It is felt that this conservative attitude toward testing ensured the delivery of a functioning unit to NRL. In this way those mechanical specifications may be tested at NRL facilities at the discretion of researchers there. All optical specification requirements were tested, and the device performed satisfactorily.

4.1 Mechanical Tests

Specifications impacting mechanical design were adopted as design goals rather than contract requirements. These goals are device lifetime of 10^6 rotations, device survival in sea water environment at 20.7 MPa pressure, survival of a 76 cm drop test, and operation under vibratory motion with maximum acceleration of 5 g. ITT EOPD has been assured by Electro-Tec engineers that achievement of lifetime and shock and vibration goals are well within the capabilities of the slip-ring capsule assembly which was constructed with their standard technology. The slip-ring capsule incorporates fluorosilicone seals to prevent infiltration by sea water, and a pressure equalization bellows could be added to future designs for pressurized environments. Similarly, ITT EOPD

1

feels that survival of the optical components under the proposed tests has a high probability. However, since the tests were not mandatory, they were deferred to ensure delivery of a functioning unit. In this way, the tests may be performed by the customer at his facility and at his discretion.

4.2 Optical Specifications

Six tests were employed to characterize the optical performance of the device. They were designed to test attenuation, dispersion, rotational variation, and temperature survivability of the rotary joint, as well to ensure that the fiber optic cable used met contract specifications.

4.2.1 Cable Specifications

Cable specifications were obtained from normal quality assurance tests to which all cables manufactured at ITT EOPD are submitted. These measurements are summarized in Table 4.2.1-1.

4.2.2 Optical Loss

Insertion loss measurements of the device were derived with the aid of an apparatus which produces attenuation and dispersion measurements of optical fibers at two wavelengths by using high speed pulse techniques. Using lasers driven by high speed pulsed electronics, a pulse of light is injected into the fiber being tested and is then detected by a photodiode as light intensity as

Table 4.2.1-1. Cable Specifications.

Cable S/N:	060281-2C2B
Cable type:	RT 211-22B
Cable description:	Single-fiber cable with 20 mil fiber jacket
Fiber identification:	810512-22b
Preform number:	PG 80721
Date of measurement:	6-2-81
Core diameter:	51 x 52 μm (SOP) 50 x 51 μm (EOP)
Cladding diameter:	125 x 126 μm (SOP) 124 x 125 μm (EOP)
Attenuation:	3.43 dB/km
Dispersion:	0.87 ns/km (50%) 1.98 ns/km (10%)
Numerical aperture:	0.22
Length:	11.88 m

a function of time. Without disturbing injection conditions, the fiber is cut a short (~1 m) distance from the injection end, and the light out of the short fiber is similarly detected. Assuming that the short piece of fiber is essentially lossless, the power out of the short length of fiber is a reasonable gage of the power injected into the test fiber. Dispersion is calculated from the temporal difference in the two pulses, and attenuation is derived by comparing the total energy in each pulse after integration of the intensity (power) with respect to time.

The results are tabulated in Table 4.2.2-1. These results should be tempered by the observation that the insertion loss measured is very dependent on optical launch conditions. Despite the use of a mode scrambler (three concatenated fibers of differing core sizes and refractive index profiles) to attempt an excitation of the complete modal volume that the cable is capable of sustaining, it is suspected that the dual wavelength apparatus used tended to underfill the cable. This would lead to a preferential excitation of low order modes, which would be less severely attenuated in the rotary joint than high order modes. An investigation into launch conditions present on the apparatus in question is currently proceeding at ITT EOPD.

4.2.3 Dispersion

There was no measurable difference between output and input

Table 4.2.2-1. Insertion Losses.

Wavelength:	0.83 μm	1.3 μm
Injection end:	P4	P4
Date:	4-9-82	4-9-82
Insertion loss:	1.03 dB	1.44 dB

(cutback) pulses during the dispersion test. Therefore, the rotary joint dispersion is well below 300 ps, which is within the resolution capability of the measurement system.

4.2.4 Rotational Variation

A variation of the attenuation test using the dual wavelength apparatus was used to test for dependence of optical throughput on angular position. For this test, the rotary joint was fixtured in a test jig that enabled the angular position of the rotor with respect to the stator to be indicated. A pseudorandom number algorithm was used to generate a chart of 50 numbers from 0 to 360, inclusive. The rotary joint rotor was turned an angle corresponding to each of those numbers, and at each angle the pulse energy through the rotary joint was measured as previously described. After throughput at all angles was recorded, the injection end of the cable was cut back for measurement of input pulse energy. These results are tabulated in Tables 4.2.4-1 and 4.2.4-2.

4.2.5 Oscillatory Motion Test

For the oscillatory motion test, the rotary joint was connected to a test fixture that provided a 400° oscillatory rotation of the rotor at a rate of 10 oscillations per minute. The test was performed at both 0.83 μm and 1.3 μm wavelengths. One end of the cable was fusion spliced to an LED of the appropriate wavelength,

Table 4.2.4-1. Rotational Variation at $\lambda = 0.83 \mu\text{m}$.

<u>Measurement Number</u>	<u>Angle</u>	<u>Insertion Loss (dB)</u>	<u>Measurement Number</u>	<u>Angle</u>	<u>Insertion Loss (dB)</u>
1	246	1.41	26	284	1.50
2	67	1.16	27	252	1.49
3	109	1.20	28	250	1.37
4	58	1.36	29	114	1.28
5	8	1.29	30	329	1.49
6	195	1.30	31	88	1.29
7	159	1.16	32	204	1.41
8	278	1.28	33	77	1.33
9	314	1.32	34	237	1.48
10	206	1.35	35	24	1.36
11	117	1.44	36	58	1.35
12	31	1.31	37	78	1.29
13	215	1.40	38	209	1.42
14	54	1.42	39	221	1.36
15	309	1.35	40	241	1.46
16	178	1.39	41	103	1.35
17	244	1.48	42	255	1.42
18	53	1.39	43	19	1.30
19	224	1.39	44	7	1.34
20	11	1.41	45	184	1.36
21	328	1.39	46	154	1.34
22	58	1.28	47	48	1.25
23	37	1.35	48	348	1.42
24	190	1.38	49	315	1.47
25	267	1.51	50	49	1.32

Table 4.2.4-2. Rotational Variation at $\lambda = 1.3 \mu\text{m}$.

<u>Measurement Number</u>	<u>Angle</u>	<u>Insertion Loss (dB)</u>	<u>Measurement Number</u>	<u>Angle</u>	<u>Insertion Loss (dB)</u>
1	6	1.12	26	254	1.26
2	182	1.26	27	348	1.14
3	19	1.12	28	117	1.14
4	61	1.08	29	259	1.31
5	254	1.32	30	337	1.15
6	91	1.18	31	113	1.11
7	82	1.14	32	266	1.23
8	313	1.23	33	38	1.03
9	277	1.29	34	149	1.20
10	45	1.15	35	277	1.29
11	281	1.23	36	137	1.14
12	266	1.18	37	347	1.16
13	26	1.05	38	121	1.18
14	296	1.21	39	277	1.35
15	289	1.29	40	202	1.24
16	301	1.22	41	268	1.32
17	93	1.13	42	106	1.23
18	153	1.22	43	273	1.23
19	111	1.08	44	224	1.28
20	57	0.99	45	319	1.29
21	93	1.08	46	68	1.18
22	261	1.29	47	290	1.25
23	182	1.25	48	9	1.09
24	99	1.11	49	160	1.17
25	243	1.33	50	58	1.13

and the other end was fixed to a photodiode with the proper spectral sensitivity. A load resistor was used to convert the photocurrent developed to a voltage which was recorded as a function of time by a chart recorder. The optical throughput was recorded for over 100 oscillations, yielding maximum variations of 0.25 dB at 0.83 μm and 0.21 dB at 1.3 μm . Samples of the recordings are given in Figures 4.2.5-1 and 4.2.5-2.

4.2.6 Temperature Cycling Test

Operation of the rotary joint over extremes of temperature from 0°C to +60°C was adopted as a contract goal rather than a requirement. However, ITT EOPD felt sufficient confidence in the durability of its optical design to submit the finished assembly to temperature testing. The test chosen used a 5 h cycle between 0°C and +60°C repeated three times. The same LED/photodiode pairs employed in the rotational variation test were used with the chart recorder to record changes in optical throughput.

Tests performed at both wavelengths of interest indicate no catastrophic failures and no changes in optical throughput that could be correlated with temperature changes. The chart recording of the test at 1.3 μm is given in Figure 4.2.6-1. The test at 0.83 μm produced a similar chart (see Figure 4.2.6-2) although a 60 Hz vibration, erroneously coupled inductively into the detector circuit, makes it difficult to extract to exact any more useful information than the lack of any catastrophic failure..

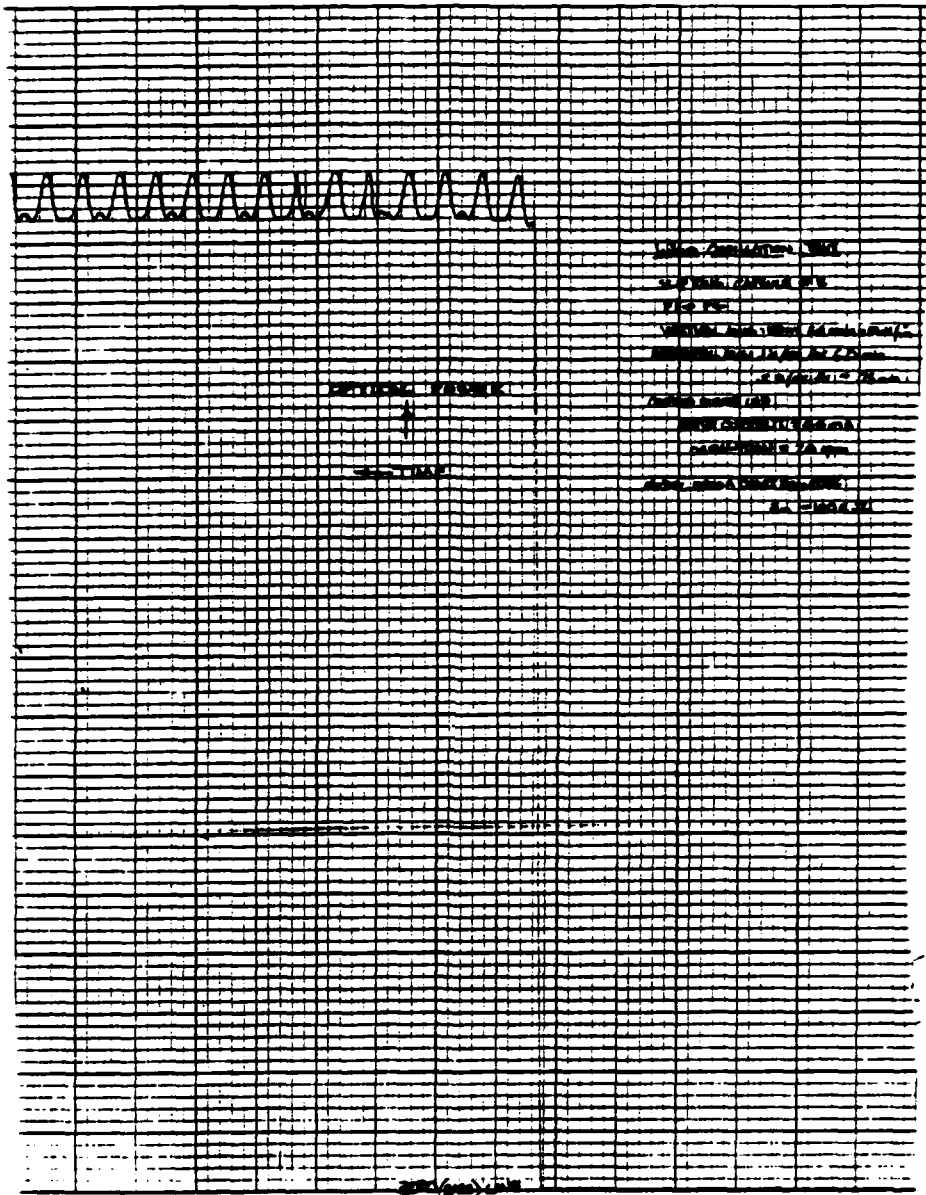

Figure 4.2.5-1. Oscillatory Motion Test at $\lambda = 1.3 \mu\text{m}$.

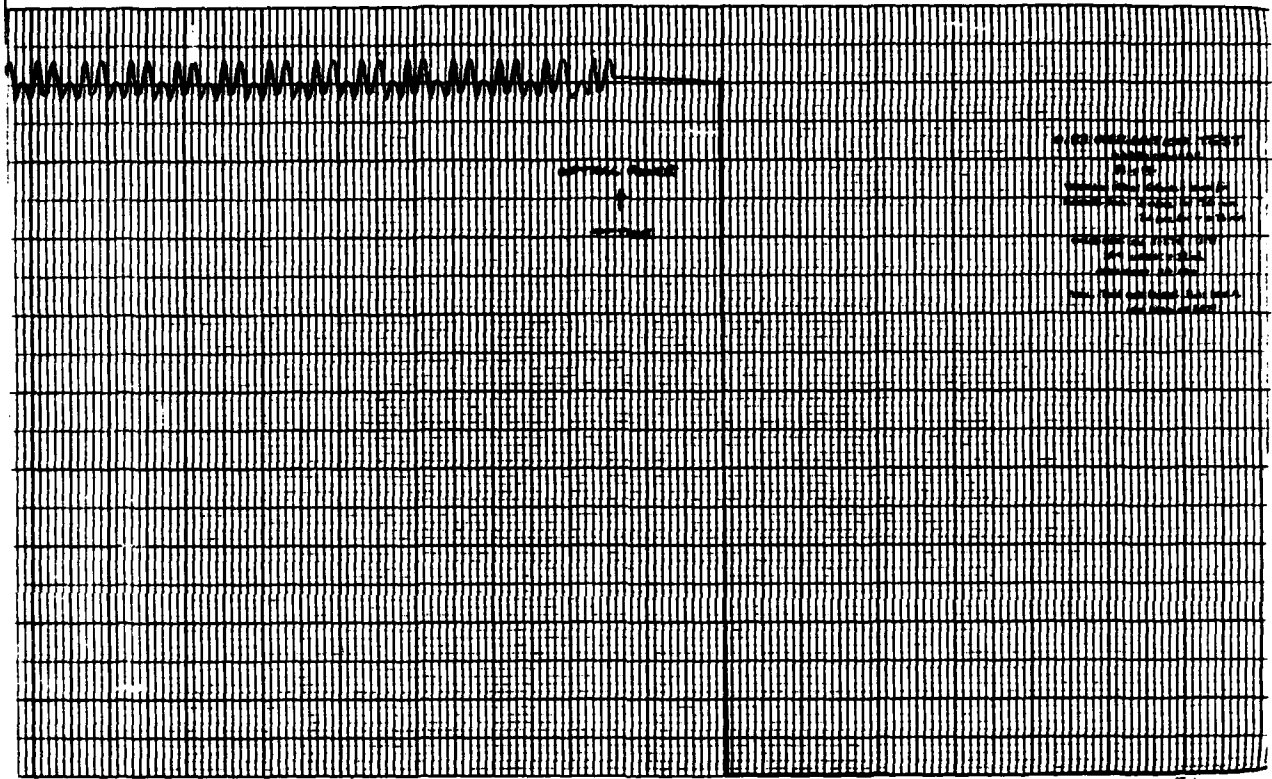

Figure 4.2.5-2. Oscillatory Motion Test at $\lambda = 1.3 \mu\text{m}$.

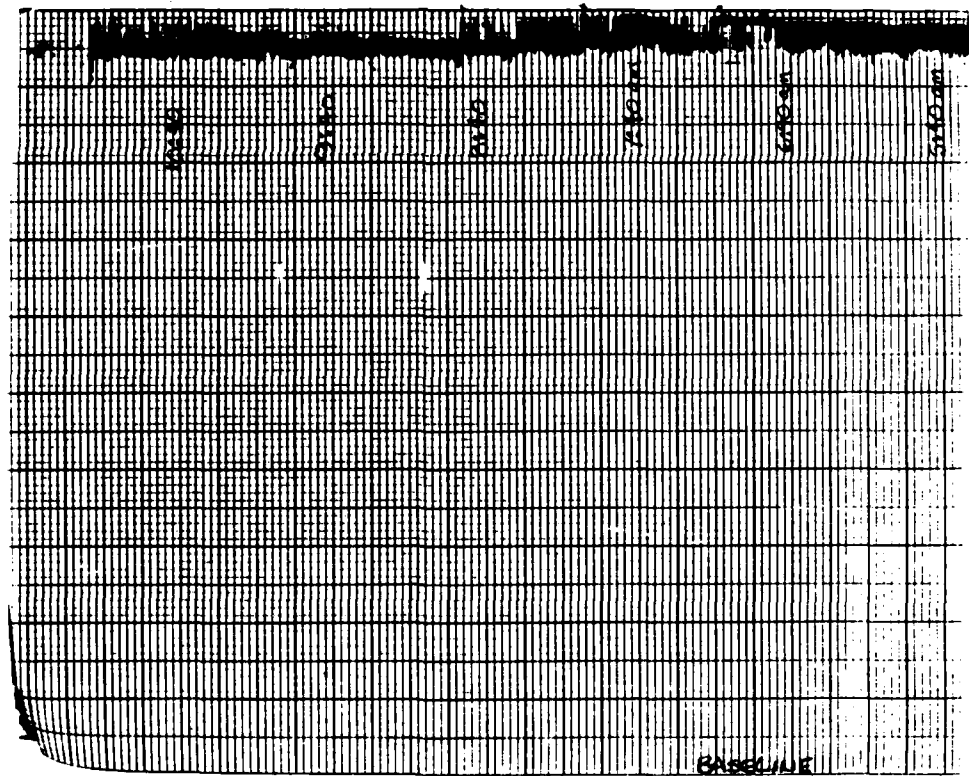
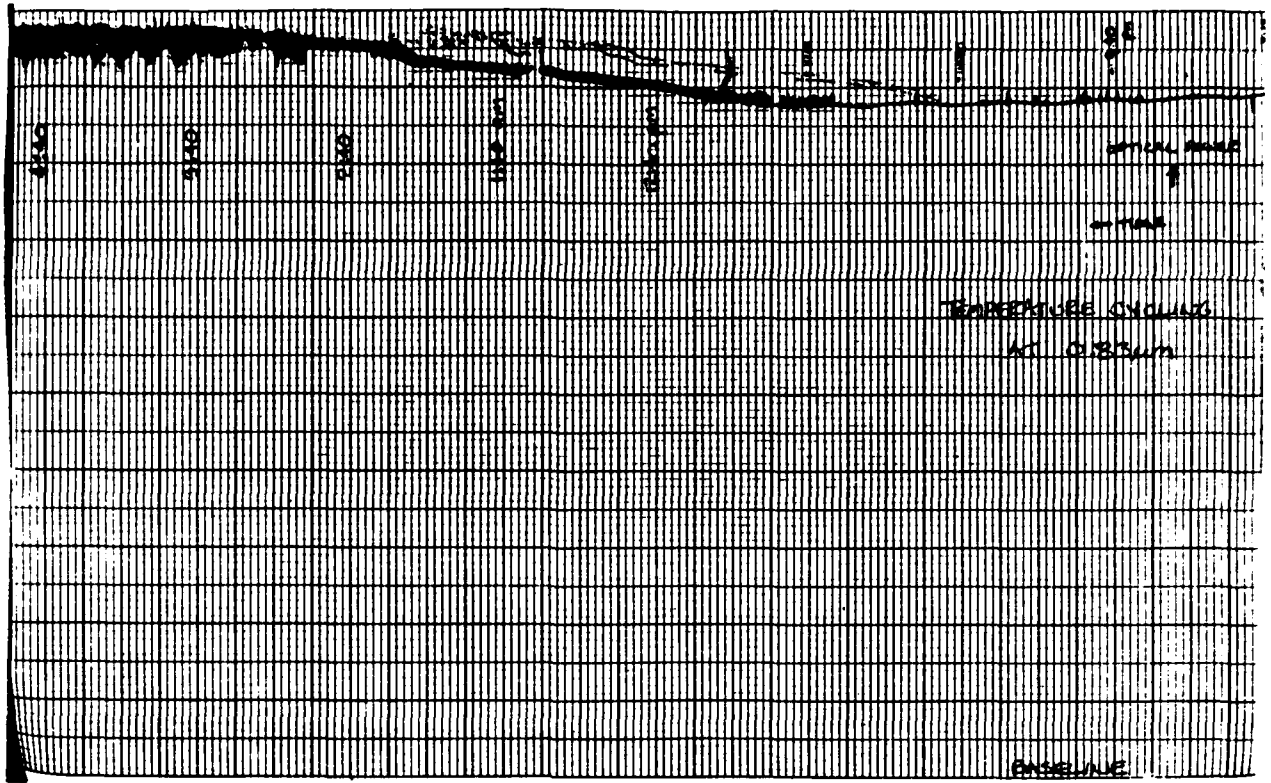

Figure 4.2.6-1. Temperature Cycling at 0.83 um.

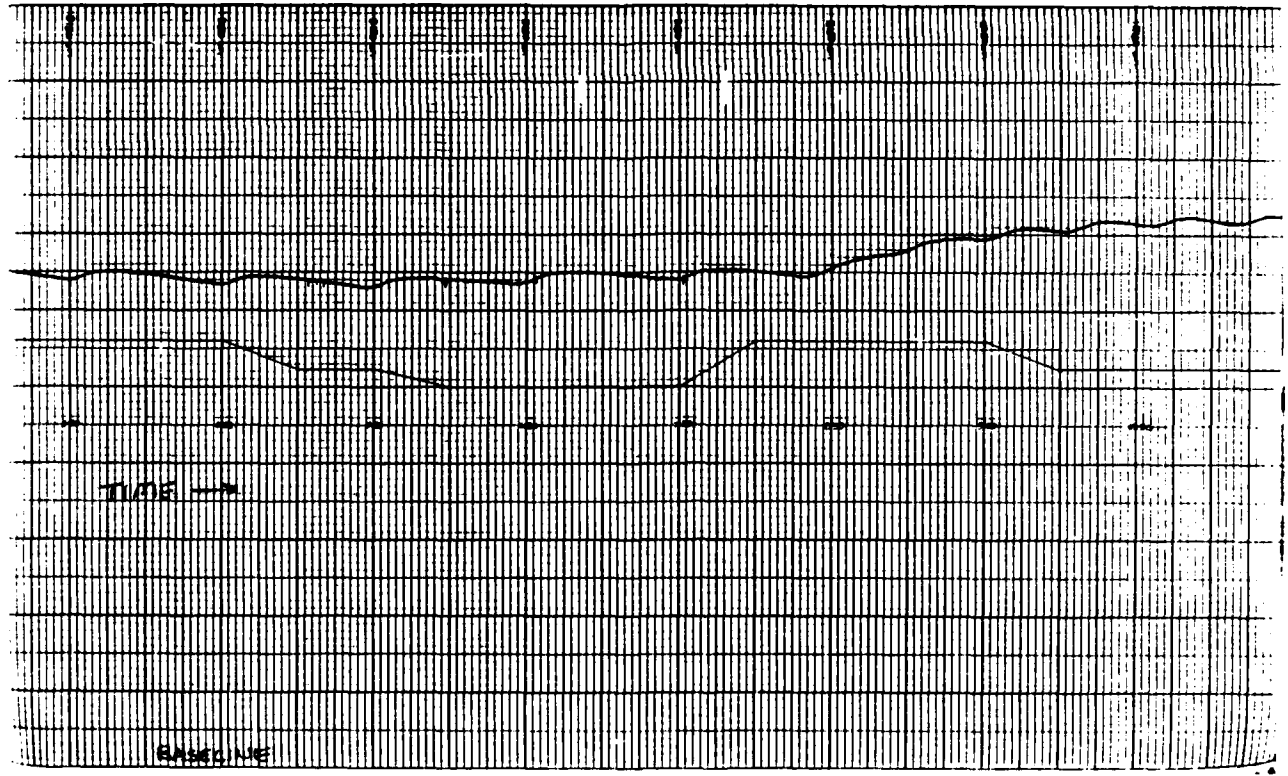

Figure 4.2.6-2. Temperature Cycling at 1.3 μm .

5.0 CONCLUSION

The conclusion of this contract has seen the creation of an optical rotary joint with extremely low insertion loss and negligible dispersion. Very low wow (percent variation of optical power throughput with rotation) of 5% suggests that the device should serve very well in an analog communications link. Although mechanical performance was not tested (beyond its impact on optical performance), it is the belief of ITT EOPD that the device should satisfy most criteria for military applications.

