

①

DUNN

AD A117352

A NEW ANALYSIS OF THE UNWINDING RIBBON AS A DELAYED ARMING DEVICE (U)

*WILLIAM P. DUNN, Ph.D.
US ARMY LARGE CALIBER
WEAPON SYSTEMS LABORATORY
DOVER, NJ 07801

1. INTRODUCTION

The objective of this work was to formulate theoretical methods to enable engineers to design unwinding ribbons for use as delay arming mechanisms with reasonable accuracy and a minimum development effort. The unwinding ribbon considered here is a "wrapped" spring, which is a spiral spring made from flat metal stock closely wound. In the unstressed condition all the coils of the spring are touching. The results of the analysis are given and compared with the experimental results obtained by T.B. Alfriend.

This is a more complete study than that of Alfriend since no assumptions are made concerning the moment of inertia of the coil and hub or the tension force in the ribbon bridge. Hence, two empirical constants in Alfriend's analysis were dropped in favor of exact expressions.

2. DESCRIPTION OF UNWINDER DEVICE

The basic components of the Unwinder device are shown schematically in Figure 1. The spring, A, is wrapped around and fastened at its inner end to the shaft, B. The outer end of the spring is fastened to the outer case, C, at the point D. The outer case, C, is fixed to and rotates with the projectile. The axis of the spring and of the inner shaft, B, are coincident with the longitudinal axis of the projectile as shown in Figure 1. Upon firing, torsional acceleration causes the spring to wind up tightly. After the torsional acceleration ceases, the centrifugal forces acting on the spring will tend to unwind it. During this unwinding process, the inner shaft, B, will rotate relative to the housing, and this motion can be used to close a switch, to rotate a firing pin in line with a detonator or to cause other arming processes.

*"Study of Wrapped Springs for Application to a Delayed Arming Device"- T.B. Alfriend - Summary Report ER-1404 Aircraft Armaments Inc.-1958.

DTIC FILE COPY

DTIC ELECTED
JUL 20 1982

DISTRIBUTION STATEMENT A
Approved for public release;
Distribution Unlimited

DUNN

3. ALFRIEND'S ANALYSIS

To write the differential equation of motion of the spring unwinding due to the action of centrifugal forces, Alfrend* assumed that the unbalanced torque on the inner shaft is a function of $K\omega^2$, where ω is the net angular velocity of the unbalanced spring mass and K is some experimentally determined constant. Pictorially, Alfrend represented the physical problem as shown in Figure 2.

The internal force vectors F and M are such that

M = the torque required to deflect the spring statically from its initial unstressed state with radius r , to the radius of the outer case, r_0 ;

F = the tensile force in the spring due to centrifugal forces acting on the unbalanced length of the spring between points A and B, which are the points of contact between the stretched and coiled spring material at the inner and outer coils, respectively. The initial positions of these points are designated A_0 and B_0 .

The appropriate Euler differential equation of motion for the inner shaft and attached spring is then

$$Fr + M = I\ddot{\theta} \quad (1)$$

where θ is the relative angular displacement of the shaft with respect to the outer case. The moment of inertia, I , of the total revolving mass on the inner shaft is a function of the radius, r , which decreases as the spring unwinds. Alfrend assumed

$$I = I_0 + c\theta \quad (2)$$

where,

I_0 = the initial moment of inertia of the spring plus the inner shaft

c = assumed constant rate of decrease in I as the spring unwinds.
Alfrend then assumed

$$F = K\omega^2 \quad (3)$$

*See reference in Introduction.



Availability Codes	
Dist	Avail and/or Special
A	

DUNN

where as aforementioned, κ is experimentally determined and ω is the total angular velocity of the unbalanced spring length. He further assumed that

$$\omega = \omega_0 - \frac{r}{r_{i0}} \dot{\theta} \quad (4)$$

where,

$$r = r_0 - \frac{\delta}{2\pi} \theta \quad (5)$$

and,

ω_0 = constant angular velocity of the outer case

δ = spring thickness

r_0 = initial outside radius of the spring on the inner shaft.

Substituting equations (2) - (5) into (1), the equation of motion becomes

$$\kappa \left[\omega_0 - \frac{(r_0 - \frac{\delta}{2\pi} \theta)}{r_{i0}} \dot{\theta} \right]^2 (r_0 - \frac{\delta}{2\pi} \theta) + M = (I_0 - c\theta) \ddot{\theta} \quad (6)$$

where,

$$M = \frac{1}{24} E b \delta^3 r_{i0} \left(\frac{1}{r_{i0}} - \frac{1}{r_{o0}} \right)^2 \quad (6-A)$$

and,

E = the elastic modulus (Young's) of the spring material

b = the width of the spring material

r_{i0} = the radius of the inner shaft

r_{o0} = the radius of the outer case

4. MODIFIED ALFRIEND THEORY

A more accurate characterization of the behavior of the spring can be obtained by eliminating the assumptions made by Alfriend. To accomplish this, equations (2) and (3) are replaced by their analytically derived forms. This eliminates the two constants κ and δ introduced through the assumptions; in place of equation (2),

DUNN

$$I = \frac{1}{2} \pi b^2 \left[(S_{SN} - S_{SP}) r_0^4 + S_{SP} r^4 \right] \quad (7)$$

where S_{SN} , S_{SP} are the inner shaft and spring densities, respectively.

To revise equation (3), consider Newton's 2nd Law of Motion i.e., the force is proportional to the change in momentum with time. and let

$$m_{AB} = S_{SP} \delta l \sqrt{r_2^2 - r^2} \quad \approx \quad \text{mass of the spring material between points "A" and "B" in Figure 3} \quad (8)$$

$$\underline{r}_{CM} = \frac{1}{2} (r_2 + r) \quad \approx \quad \text{the position vector to the center of mass of material between the points "A" and "B" in Figure 3} \quad (9)$$

$$\underline{v}_{CM} = \frac{d}{dt} (\underline{r}_{CM}) \quad \approx \quad \text{the velocity vector of the mass center of the material between the points "A" and "B" in Figure 3} \quad (10)$$

where

$$\underline{r} = \text{the position vector to the last point of contact between the inner coiled spring material and the uncoiled spring material} = (r_0 - \delta/2\pi \cdot \theta) (-\sin \theta \hat{i} + \cos \theta \hat{j}) \quad (11)$$

$$\underline{r}_2 = \text{the position vector to the last point of contact between the outer coiled spring material and the uncoiled spring material} \\ \underline{r}_2 = (r_0 - \delta/2\pi \cdot \alpha) [\cos(\lambda + \theta) \hat{i} + \sin(\lambda + \theta) \hat{j}] \quad (12)$$

and

r_0 = the initial radius of the last point of contact between the inner coiled spring and the uncoiled spring.

r_{i0} = the inner radius to the outer case

θ = the angle delineating the material unwrapped from the inner core

α = the angle delineating the material wrapped onto the outer case

λ = angle between the position vector \underline{r}_2 and the uncoiled material = $\sin^{-1}(r/r_2)$

$$r = \text{the scalar value of } |\underline{r}| = r_0 - (\delta/2\pi) \theta \quad (13)$$

$$r_2 = \text{the scalar value of } |r_2| = r_2 - (\delta/2\pi)\omega \quad (14)$$

Thus, the force acting on the ribbon segment (\overline{AB}) is,

$$\underline{F}_{AB} = \frac{d}{dt}(m_{AB} \underline{V}_{cm}) = \frac{dm_{AB}}{dt} \underline{V}_{cm} + m_{AB} \frac{d\underline{V}_{cm}}{dt} \quad (15)$$

where,

$$\frac{dm_{AB}}{dt} = - \frac{S_3 \delta^2 b (r_2 \ddot{\alpha} - r \dot{\theta})}{2\pi \sqrt{r_2^2 - r^2}} \quad (16-A)$$

and in place of equation (6-A), we define

$$M = \frac{1}{24} E \delta^3 r \left(\frac{1}{r} - \frac{1}{r_2} \right)^2 \quad (16-B)$$

The transformation expressions relating the coordinate system fixed in the inner shaft to the ground reference coordinate system are:

$$\left. \begin{aligned} \hat{i} &= \cos \omega_0 t \hat{I} - \sin \omega_0 t \hat{J} \\ \hat{j} &= \sin \omega_0 t \hat{I} + \cos \omega_0 t \hat{J} \end{aligned} \right\} \quad (17)$$

$$\left. \begin{aligned} \hat{I} &= \cos \omega_0 t \hat{i} + \sin \omega_0 t \hat{j} \\ \hat{J} &= -\sin \omega_0 t \hat{i} + \cos \omega_0 t \hat{j} \end{aligned} \right\} \quad (18)$$

Substituting equations (17) into equations (9), (10) and $d\underline{V}_{cm}/dt$ yields, upon simplification,

$$\underline{r}_{cm} = \frac{1}{2} \left\{ [r_2 \cos(\lambda + \theta - \omega_0 t) - r \sin(\theta - \omega_0 t)] \hat{I} + [r_2 \sin(\lambda + \theta - \omega_0 t) + r \cos(\theta - \omega_0 t)] \hat{J} \right\} \quad (19)$$

$$\underline{V}_{cm} = \frac{1}{2} \left\{ [r_2 \dot{\alpha} \cos(\lambda + \theta - \omega_0 t) - \dot{r} \sin(\theta - \omega_0 t) - r_2(\dot{\lambda} + \dot{\theta} - \omega_0) \sin(\lambda + \theta - \omega_0 t) - r(\dot{\theta} - \omega_0) \cos(\theta - \omega_0 t)] \hat{I} \right. \\ \left. + [r_2 \dot{\alpha} \sin(\lambda + \theta - \omega_0 t) + \dot{r} \cos(\theta - \omega_0 t) + r_2(\dot{\lambda} + \dot{\theta} - \omega_0) \cos(\lambda + \theta - \omega_0 t) - r(\dot{\theta} - \omega_0) \sin(\theta - \omega_0 t)] \hat{J} \right\} \quad (20)$$

$$\frac{d\underline{V}_{cm}}{dt} = \frac{1}{2} \left\{ [r_2 \ddot{\alpha} - r_2(\dot{\lambda} + \dot{\theta} - \omega_0)^2] \cos(\lambda + \theta - \omega_0 t) - [\ddot{r} - r(\dot{\theta} - \omega_0)^2] \sin(\theta - \omega_0 t) \right. \\ \left. - [2\dot{r}_2(\dot{\lambda} + \dot{\theta} - \omega_0) + r_2(\ddot{\lambda} + \ddot{\theta})] \sin(\lambda + \theta - \omega_0 t) - [2\dot{r}(\dot{\theta} - \omega_0) + r\ddot{\theta}] \cos(\theta - \omega_0 t) \right\} \hat{I} \\ + \frac{1}{2} \left\{ [r_2 \ddot{\alpha} - r_2(\dot{\lambda} + \dot{\theta} - \omega_0)^2] \sin(\lambda + \theta - \omega_0 t) + [\ddot{r} - r(\dot{\theta} - \omega_0)^2] \cos(\theta - \omega_0 t) \right. \\ \left. + [2\dot{r}_2(\dot{\lambda} + \dot{\theta} - \omega_0) + r_2(\ddot{\lambda} + \ddot{\theta})] \cos(\lambda + \theta - \omega_0 t) - [2\dot{r}(\dot{\theta} - \omega_0) + r\ddot{\theta}] \sin(\theta - \omega_0 t) \right\} \hat{J} \quad (21)$$

DUNN

Defining,

$$r_c \equiv \sqrt{r_1^2 - r^2} \quad (22)$$

and noting from Figure (3) that

$$\lambda_0 + \alpha = \lambda + \theta \quad (23)$$

differentiation then provides the relations

$$\dot{\alpha} = \dot{\lambda} + \dot{\theta} \quad ; \quad \ddot{\alpha} = \ddot{\lambda} + \ddot{\theta} \quad (24)$$

Now, using equations (18) or (20) and (21); along with equations (22), (23) and (24), obtain from equation (15)

$$\begin{aligned} F_{AB} = & \frac{1}{2} \rho_p \delta b \left[\left\{ [\ddot{r}_1 - r_1 (\dot{\alpha} - \omega_0)^2] r_c - \frac{\delta r_1 (r_1 \dot{\alpha} - r \dot{\theta})}{2\pi r_c} \right\} \cos(\lambda_0 + \alpha) \right. \\ & - \left\{ [2r_1 (\dot{\alpha} - \omega_0) + r_1 \ddot{\alpha}] r_c - \frac{\delta r_1 (r_1 \dot{\alpha} - r \dot{\theta}) (\dot{\alpha} - \omega_0)}{2\pi r_c} \right\} \sin(\lambda_0 + \alpha) \\ & - \left\{ [2r (\dot{\theta} - \omega_0) + r \ddot{\theta}] r_c - \frac{\delta r (\dot{\theta} - \omega_0) (r_1 \dot{\alpha} - r \dot{\theta})}{2\pi r_c} \right\} \cos \theta \\ & - \left. \left\{ [\ddot{r} - r (\dot{\theta} - \omega_0)^2] r_c - \frac{\delta r (r_1 \dot{\alpha} - r \dot{\theta})}{2\pi r_c} \right\} \sin \theta \right] \hat{c} \\ & + \frac{1}{2} \rho_p \delta b \left[\left\{ [\ddot{r}_1 - r_1 (\dot{\alpha} - \omega_0)^2] r_c - \frac{\delta r_1 (r_1 \dot{\alpha} - r \dot{\theta})}{2\pi r_c} \right\} \sin(\lambda_0 + \alpha) \right. \\ & + \left\{ [2r_1 (\dot{\alpha} - \omega_0) + r_1 \ddot{\alpha}] r_c - \frac{\delta r_1 (r_1 \dot{\alpha} - r \dot{\theta}) (\dot{\alpha} - \omega_0)}{2\pi r_c} \right\} \cos(\lambda_0 + \alpha) \\ & - \left\{ [2r (\dot{\theta} - \omega_0) + r \ddot{\theta}] r_c - \frac{\delta r (\dot{\theta} - \omega_0) (r_1 \dot{\alpha} - r \dot{\theta})}{2\pi r_c} \right\} \sin \theta \\ & + \left. \left\{ [\ddot{r} - r (\dot{\theta} - \omega_0)^2] r_c - \frac{\delta r (r_1 \dot{\alpha} - r \dot{\theta})}{2\pi r_c} \right\} \cos \theta \right] \hat{\theta} \equiv F_1 \hat{c} + F_2 \hat{\theta} \quad (25) \end{aligned}$$

where F_1 and F_2 represent the scalar variables multiplying the unit vectors \hat{c} and $\hat{\theta}$ respectively. From Figure 3, the tension in the segment \overline{AB} is then

$$F = F_1 \cos \theta + F_2 \sin \theta \quad (26)$$

Substituting F_1 and F_2 from equation (25) into (26) and making use of the trigonometric identities

$$\begin{aligned} \sin(x \pm y) &= \sin x \cos y \pm \cos x \sin y \\ \cos(x \pm y) &= \cos x \cos y \mp \sin x \sin y \quad (27) \end{aligned}$$

yields, upon simplification,

$$\begin{aligned}
 F = \frac{1}{2} S_{sp} \delta b \left[\left\{ \left[\ddot{r}_2 - r_2 (\dot{\alpha} - \omega_0)^2 \right] r_2 - \frac{\delta \dot{r}_2 (r_2 \dot{\alpha} - r \dot{\theta})}{2\pi r_2} \right\} \cos \lambda \right. \\
 \left. + \left\{ \left[2\dot{r}_2 (\dot{\alpha} - \omega_0) + r_2 \ddot{\alpha} \right] r_2 - \frac{\delta \dot{r}_2 (r_2 \dot{\alpha} - r \dot{\theta}) (\dot{\alpha} - \omega_0)}{2\pi r_2} \right\} \sin \lambda \right. \\
 \left. - \left\{ \left[2\dot{r} (\dot{\theta} - \omega_0) + r \ddot{\theta} \right] r_2 - \frac{\delta r (\dot{\theta} - \omega_0) (r_2 \dot{\alpha} - r \dot{\theta})}{2\pi r_2} \right\} \right] \quad (28)
 \end{aligned}$$

After substituting (See Figure 3),

$$\sin \lambda = \frac{r}{r_2} \quad , \quad \cos \lambda = \frac{r_2}{r} \quad (29)$$

into equation (28) and then using this result in equation (1), the following expression is obtained.

$$\begin{aligned}
 \ddot{\theta} - \frac{M}{I} = A_0 \left[r_2 \left\{ \left[\ddot{r}_2 - r_2 (\dot{\alpha} - \omega_0)^2 \right] r_2 - \frac{\delta \dot{r}_2 (r_2 \dot{\alpha} - r \dot{\theta})}{2\pi r_2} \right\} + r \left\{ \left[2\dot{r}_2 (\dot{\alpha} - \omega_0) + r_2 \ddot{\alpha} \right] r_2 \right. \right. \\
 \left. \left. - \frac{\delta \dot{r}_2 (r_2 \dot{\alpha} - r \dot{\theta}) (\dot{\alpha} - \omega_0)}{2\pi r_2} - r_2 \left\{ \left[2\dot{r} (\dot{\theta} - \omega_0) + r \ddot{\theta} \right] r_2 - \frac{\delta r (\dot{\theta} - \omega_0) (r_2 \dot{\alpha} - r \dot{\theta})}{2\pi r_2} \right\} \right] \right] \quad (30)
 \end{aligned}$$

where,

$$A_0 = \frac{S_{sp} \delta b r}{2 r_2 I} = \frac{\delta}{\pi r_2 r^2} \quad (31)$$

for the case $S_{sh} = S_{sp}$.

5. RELATIONSHIP BETWEEN WRAPPING ANGLE (α) AND UNWRAPPING ANGLE (θ):

To obtain α as a function of θ , note from Figure 3 that the material unwrapped from the inner shaft must equal the material wrapped on the outer case plus the material going into the increased length of the "bridge", \overline{AB} . Mathematically stated,

$$\int_0^\theta r_0' d\theta' = \int_0^\alpha r_2 d\alpha' + (\sqrt{r_2^2 - r^2} - \sqrt{r_0^2 - r_0'^2}) \quad (32)$$

Substituting equations (13) and (14) into equation (32) and integrating yields,

$$\left(r_0 - \frac{\delta}{4\pi} \theta \right) \theta = \left(r_2 - \frac{\delta}{4\pi} \alpha \right) \alpha + \left(\sqrt{\left(r_2 - \frac{\delta}{2\pi} \alpha \right)^2 - \left(r_0 - \frac{\delta}{2\pi} \theta \right)^2} - \sqrt{r_0^2 - r_0'^2} \right) \quad (33)$$

Expanding and simplifying equation (33) results in

$$\alpha^4 - \frac{8\pi r_{20}}{\delta} \alpha^3 + \frac{4}{\delta^2} \left[4\pi^2 r_{20}^2 + \delta^2 - 2\pi\delta \sqrt{r_{20}^2 - r_0^2} - 2\pi\delta \left(r_0 - \frac{\delta}{4\pi} \theta \right) \right] \alpha^2 - \frac{16\pi^2 r_{20}}{\delta^2} \left[\frac{\delta}{\pi} - 2\sqrt{r_{20}^2 - r_0^2} - 2 \left(r_0 - \frac{\delta\theta}{4\pi} \right) \right] \alpha + \frac{4\pi^2}{\delta^2} \left[\frac{4r_{20}\delta\theta}{\pi} - 4 \left(r_0 - \frac{\delta\theta}{4\pi} \right) \frac{\delta}{\pi} - 8 \left(r_0 - \frac{\delta\theta}{4\pi} \right) \sqrt{r_{20}^2 - r_0^2} - \left(\frac{\delta\theta}{\pi} \right)^2 \right] = 0 \quad (34)$$

6. DETERMINATION OF MAXIMUM WRAPPING AND UNWRAPPING ANGLES:

It can be seen from equation (13) and Figure 3 that the minimum value of r , r_{10} , will yield the maximum value of θ ; i.e.

$$\theta_{\text{MAX.}} = \frac{2\pi}{\delta} (r_0 - r_{10}) \quad (35)$$

The maximum wrapping angle is found by noting that

$$L = \int_0^{\alpha_{\text{MAX.}}} r_2 d\alpha + \sqrt{r_{2\text{MAX.}}^2 - r_{10}^2} = \left(r_{20} - \frac{\delta \alpha_{\text{MAX.}}}{4\pi} \right) \alpha_{\text{MAX.}} + \sqrt{\left(r_{20} - \frac{\delta \alpha_{\text{MAX.}}}{4\pi} \right)^2 - r_{10}^2}$$

Rearranging terms and squaring the radical leads to ($\alpha_{\text{MAX.}} = \alpha_M$)

$$\frac{\delta^2}{4\pi^2} \alpha_M^4 - \frac{\delta}{2\pi} r_{20} \alpha_M^3 + \left(r_{20}^2 - \frac{\delta L}{2\pi} - \frac{\delta^2}{4\pi^2} \right) \alpha_M^2 - 2 \left(L - \frac{\delta}{2\pi} \right) r_{20} \alpha_M - r_{20}^2 + r_{10}^2 + L^2 = 0 \quad (36)$$

Neglecting terms containing δ , a first approximation for equation (36) produces

$$\alpha_M^2 - \frac{2L}{r_{20}} \alpha_M + \frac{1}{r_{20}} (L^2 + r_{10}^2 - r_{20}^2) = 0 \quad (37)$$

A final approximation can be made if $L^2 \gg r_{20}^2 \gg r_{10}^2$. That is,

$$\alpha_M^2 - \frac{2L}{r_{20}} \alpha_M + \frac{L^2}{r_{20}^2} = \left(\alpha_M - \frac{L}{r_{20}} \right)^2 = 0 \Rightarrow \alpha_M \approx \frac{L}{r_{20}} \quad (38)$$

7. DETERMINATION OF r_0 , THE INITIAL OUTSIDE RADIUS

If L, δ, r_{10} and r_{20} are given, r_0 is obtained by first noting that the coil length, L , can also be determined from

$$L = \int_0^{\theta_{\text{MAX.}}} r d\theta + \sqrt{r_{20}^2 - r_0^2} = \frac{\pi}{\delta} (r_0^2 - r_{10}^2) + \sqrt{r_{20}^2 - r_0^2}$$

DUNN

Rearranging terms and squaring the radical then yields

$$r_0^4 + \frac{\delta^2}{\pi^2} \left(1 - \frac{2\pi L}{\delta} - \frac{2\pi^2 r_{10}^2}{\delta^2} \right) r_0^2 + \frac{\delta^2}{\pi^2} \left(L^2 - r_{10}^2 + \frac{2\pi L}{\delta} r_{10}^2 + \frac{\pi^2}{\delta^2} r_{10}^4 \right) = 0 \quad (39)$$

To obtain a real solution to equation (39), it is required that

$$L \leq \frac{\pi}{\delta} (r_{10}^2 - r_0^2) + \frac{\delta}{4\pi} \quad (40)$$

which is obtained by imposing the condition that the radical term in

$$r_0^2 = \frac{\delta^2}{2\pi^2} \left(\frac{2\pi^2 r_{10}^2}{\delta^2} + \frac{2\pi L}{\delta} - 1 \right) \pm \sqrt{\frac{\delta^4}{4\pi^2} \left(1 - \frac{2\pi L}{\delta} - \frac{2\pi^2 r_{10}^2}{\delta^2} \right)^2 - \frac{\delta^2}{\pi^2} \left(L^2 - r_{10}^2 + \frac{2\pi L}{\delta} r_{10}^2 + \frac{\pi^2}{\delta^2} r_{10}^4 \right)} \quad (41)$$

be real. Taking the positive sign in equation (41) to insure a real root, provides the relation

$$r_0 = \sqrt{\left(r_{10}^2 + \frac{\delta L}{\pi} - \frac{\delta^2}{2\pi^2} \right) + \frac{\delta}{\pi} \sqrt{\frac{\delta^2}{4\pi^2} + (r_{10}^2 - r_0^2)} - \frac{\delta L}{\pi}} \quad (42)$$

8. ALGEBRAIC SIMPLIFICATION OF THE EQUATION OF MOTION (Equation (30))

For the following conditions:

$$r_{10} > r_0 \quad ; \quad 1 \gg \frac{\delta \theta}{2\pi r_0} \quad ,$$

equation (33) provides the relationship

$$\alpha = \frac{2\pi r_{10}}{\delta} - \sqrt{\left(\frac{2\pi r_{10}}{\delta} \right)^2 - \left(\frac{4\pi r_0}{\delta} - \theta \right) \theta} \quad (43)$$

Substituting equation (43) into equation (22) results in

$$r_c = \sqrt{r_{10}^2 - r_0^2} \quad (44)$$

Thus, using equation (44) and taking the time derivative of equation (22)

$$\frac{dr_2}{dt} = \frac{1}{2} (r_2^2 - r_1^2)^{-\frac{1}{2}} (2r_2 \dot{r}_2 - 2r_1 \dot{r}_1) = 0 \quad (45)$$

By differentiating equations (13) and (14) the following time derivative relations are obtained:

$$\begin{aligned} \dot{r} &= -\frac{\delta}{2\pi} \dot{\theta} & , & & \ddot{r} &= -\frac{\delta}{2\pi} \ddot{\theta} \\ \dot{r}_2 &= -\frac{\delta}{2\pi} \dot{\alpha} & , & & \ddot{r}_2 &= -\frac{\delta}{2\pi} \ddot{\alpha} \end{aligned} \quad (46)$$

Hence, from equations (45) and (46),

$$r_2 \dot{\alpha} - r \dot{\theta} = 0 \quad (47)$$

and,

$$\ddot{\alpha} = \frac{r}{r_2} \ddot{\theta} \quad ; \quad \ddot{\alpha} = \frac{r}{r_2} \ddot{\theta} - \frac{\delta}{2\pi} \frac{r_2^2}{r_2^3} \dot{\theta}^2 \quad (48)$$

Substituting equations (46), (47) and (48) back into equation (30), simplifying and rearranging yields

$$\ddot{\theta} + A_2 \dot{\theta}^2 - A_3 \dot{\theta} + A_4 = 0 \quad (49)$$

where,

$$\begin{aligned} A_2 &\equiv \frac{A_0}{A_1 r_2^2} \left[r^2 r_2^2 r_2 + \frac{\delta r r_2^2}{4\pi} (2r_2 - r_2) - \frac{\delta^2 r_2^4}{4\pi^2 r_2^3} \right] \\ A_3 &\equiv \frac{A_0}{A_1} r_0 \omega_0 \left(2r r_2 + \frac{\delta r^2}{2\pi r_2} - \frac{\delta r_2}{\pi} \right) \\ A_4 &\equiv -M/A_1 I + A_0 (r_0 \omega_0)^2 r_2 / A_1 \\ A_1 &\equiv 1 - r_2 A_0 (r^2 - r r_2 - \delta r_0 / 2\pi) \\ A_0 &\equiv \delta / \pi r_2 r^3 \end{aligned} \quad (50)$$

These equations together with the initial values,

$$\theta(t=0) = 0 \quad ; \quad \dot{\theta}(t=0) = 0 \quad (51)$$

completely define the unwrapping angle as a function of time.

9. EXPERIMENTAL PARAMETERS

To evaluate equation (49) for its accuracy in predicting the arming time of an unwinder fuze, a comparison is made between Alfriend's experimental test data and the analytic results. The parameters for Alfriend's experiments are given in Table 1.

10. RESULTS, CONCLUSIONS AND DISCUSSION

Analytic and experimental results are plotted in Figures 4 through 10. Surveying these results, it is found that springs 1, 3, 4, 6 and 7 provide a good correspondence between theory and experiment, with the correlation becoming increasingly better as the angular velocity of the outer case increases. The poorest theoretical-experimental correspondence occurs with springs 2 and 5, although the trend of the relative turns versus time data with increasing outer case spin is predicted.

It is interesting to note that the fall-off of experimental data points from analytically determined points in spring 5 (at a relatively high outer case spin) appears similar to that for the lowest outer case spin rate for spring 1.

Without a thorough knowledge of experimental procedures, devices and data, the reasons for differences between experimental and analytic results cannot rationally be examined. How well the mathematical model will describe the results of an experiment depends on how well the experimental set-up is true to the conditions of the mathematical model. Since the data used in this report must be taken and used as reported, the reason(s) for the discrepancies between analytic and experimental results was not sought.

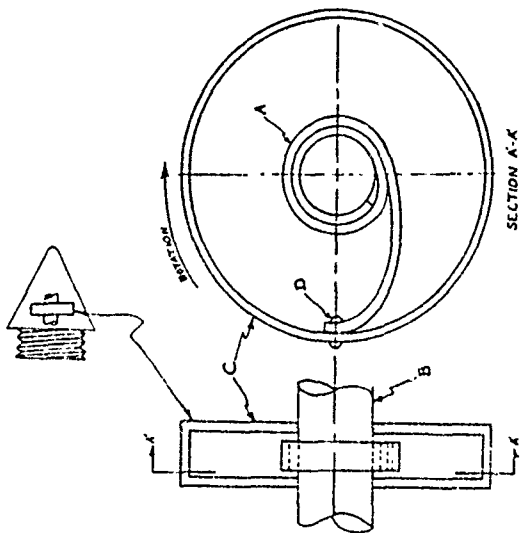

FIGURE 1: DELAYED ARMING DEVICE

Spring No.	Mat'l	E (PSI)	δ (IN)	γ_{10} (IN)	γ_{20} (IN)	b (IN)	L (IN)	S_{max} (LB/IN ³)	M (IN-LB)	θ_{MAX} (RADS)	α_{MAX} (RADS)	C_{50} (RPM)
1	302 / 301 Stainless Steel	30X10 ⁶	0.003	0.26	1.0	0.5	71.0	0.23	0.03554	226	71.9	4,200 4,840 5,400 6,000
2	1095 Carbon Steel	30X10 ⁶	0.002	0.26	1.0	0.25	38	0.29	0.00526	138	37	4,000 5,000 6,120
3	1095 Carbon Steel	30X10 ⁶	0.002	0.4	1.1	0.25	70	0.29	0.00225	157	64.6	3,960 4,800 6,000
4	1095 Carbon Steel	30X10 ⁶	0.002	0.5	1.2	0.25	80	0.29	0.0017	157	67.6	3,000 3,711 4,948
5	1095 Carbon Steel	30X10 ⁶	0.004	0.26	1.0	0.25	39.5	0.29	0.04212	133.5	40.46	7,000
6	1095 Carbon Steel	30X10 ⁶	0.004	0.4	1.1	0.25	70	0.29	0.0202	157	64.6	4,140 4,800 6,666
7	1095 Carbon Steel	30X10 ⁶	0.004	0.5	1.2	0.25	80	0.29	0.0136	146.1	67.6	3,261 3,711 4,999

TABLE 1: Experimental Parameters From "Study of Wrapped Springs for Application to a Delayed Arming Mechanism" -- Summary Report ER-1404-Aircraft Armaments Inc. Contract No. DA-36-034-501-ORD-74RD, June 1958

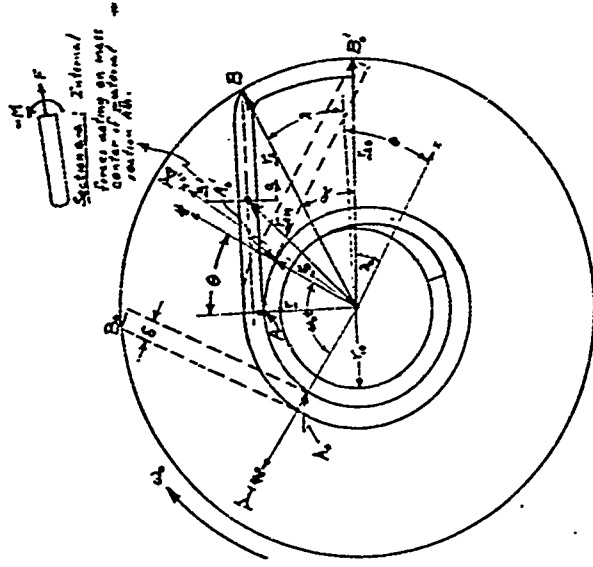

FIGURE 3: GEOMETRY, TRACTIONS AND POSITIONAL IDENTIFIERS FOR MODIFIED ALFRIEND PROBLEM

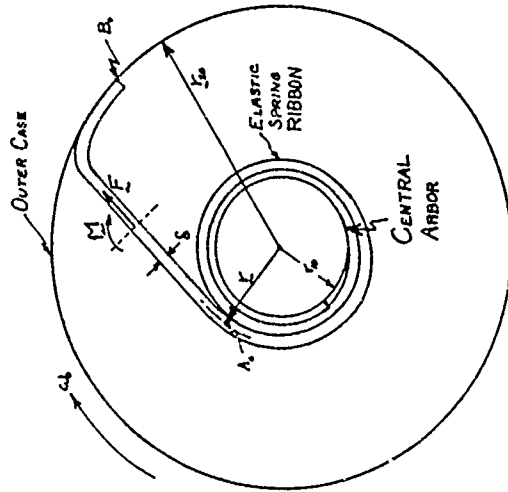
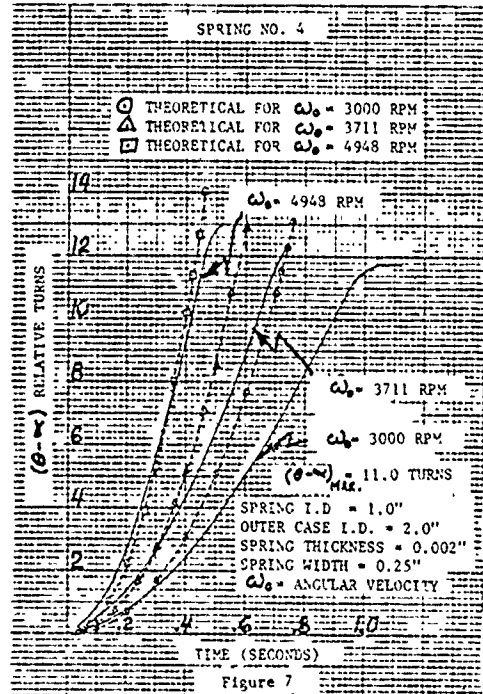
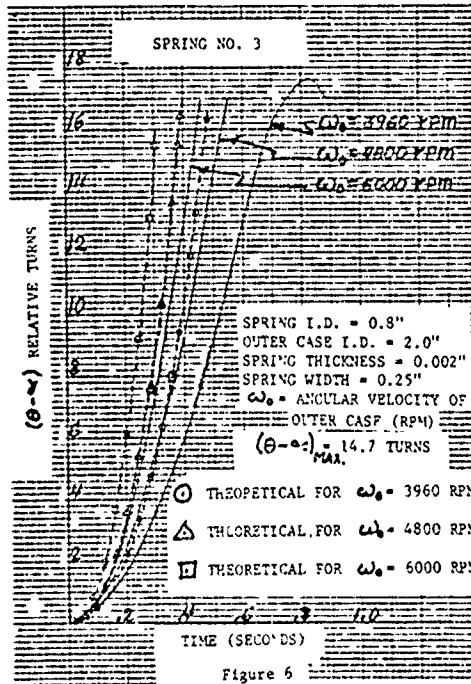
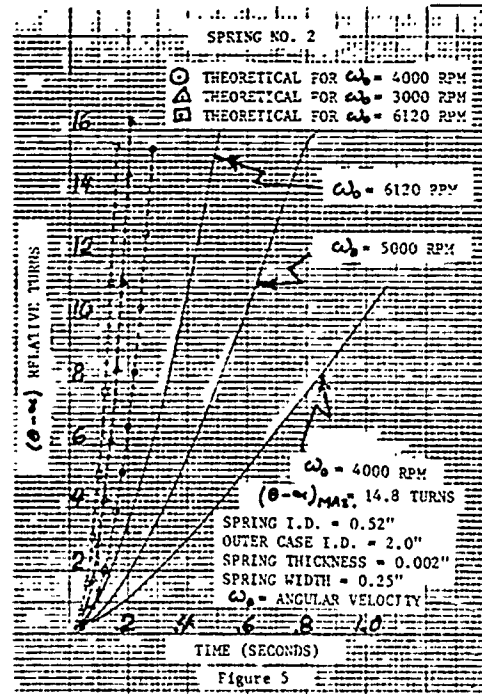
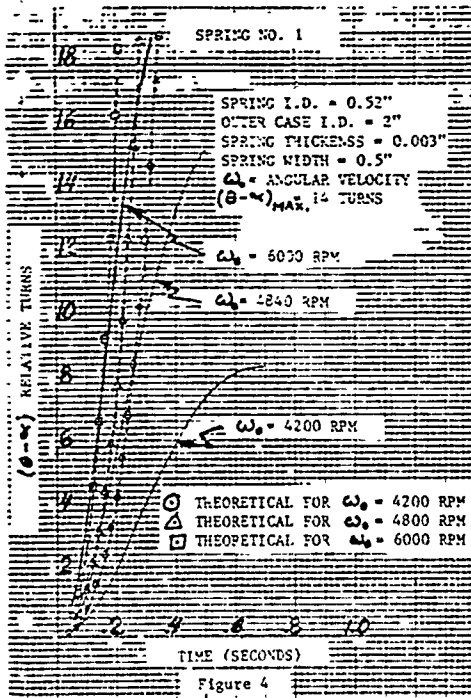

FIGURE 2: T.B. ALFRIEND'S PROBLEM



DUNN

