

AD A117386

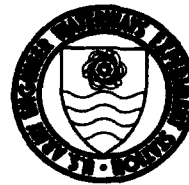
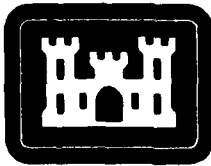

12

INSTRUCTION REPORT K-82-6

USER'S GUIDE: COMPUTER PROGRAM FOR ANALYSIS OF BEAM-COLUMN STRUCTURES WITH NONLINEAR SUPPORTS (CBEAMC)

by

William P. Dawkins
2801 Black Oak Drive
Stillwater, Okla. 74074

June 1982
Final Report

A report under the Computer-Aided Structural Engineering (CASE) Project

DTIC
ELECTE
JUL 23 1982
S B D

Approved For Public Release; Distribution Unlimited

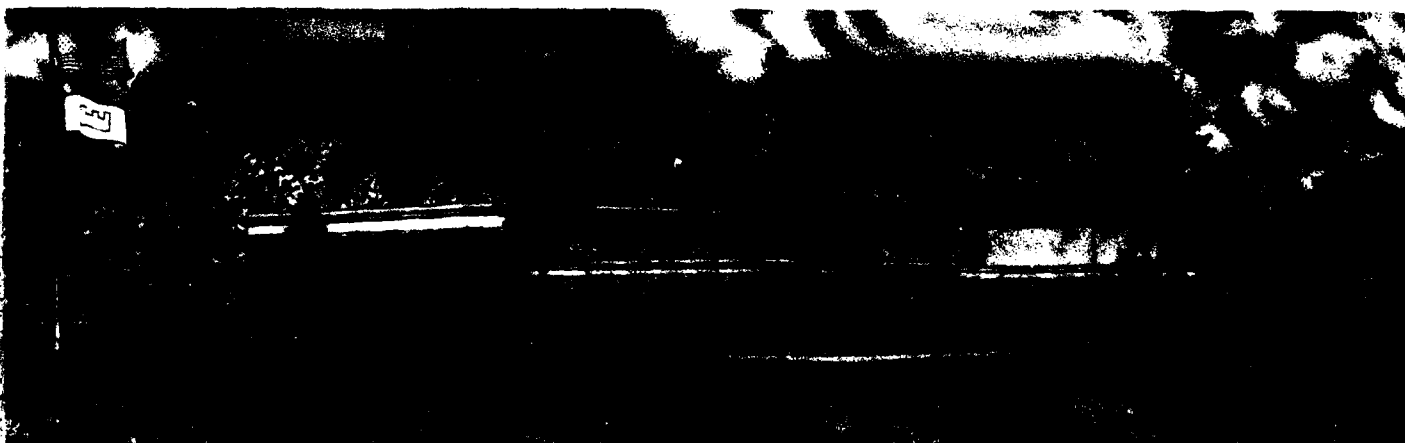

FILE COPY

Prepared for Office, Chief of Engineers, U.S. Army
Washington, D.C. 20314
Monitored by Automatic Data Processing Center
U.S. Army Engineer Waterways Experiment Station
P. O. Box 631, Vicksburg, Miss. 39180

82 07 23 004

Destroy this report when no longer needed. Do not return
it to the originator.

The findings in this report are not to be construed as an official
Department of the Army position unless so designated
by other authorized documents.

The contents of this report are not to be used for
advertising, publication, or promotional purposes.
Citation of trade names does not constitute an
official endorsement or approval of the use of
such commercial products.

Unclassified

SECURITY CLASSIFICATION OF THIS PAGE (When Data Entered)

REPORT DOCUMENTATION PAGE		READ INSTRUCTIONS BEFORE COMPLETING FORM
1. REPORT NUMBER Instruction Report K-82-6	2. GOVT ACCESSION NO. AD-A117386	3. RECIPIENT'S CATALOG NUMBER
4. TITLE (and Subtitle) USER'S GUIDE: COMPUTER PROGRAM FOR ANALYSIS OF BEAM-COLUMN STRUCTURES WITH NONLINEAR SUPPORTS (CBEAMC)	5. TYPE OF REPORT & PERIOD COVERED Final report	
	6. PERFORMING ORG. REPORT NUMBER	
7. AUTHOR(s) William P. Dawkins	8. CONTRACT OR GRANT NUMBER(s)	
9. PERFORMING ORGANIZATION NAME AND ADDRESS William P. Dawkins 2801 Black Oak Drive Stillwater, Okla. 74074	10. PROGRAM ELEMENT, PROJECT, TASK AREA & WORK UNIT NUMBERS	
11. CONTROLLING OFFICE NAME AND ADDRESS Office, Chief of Engineers, U. S. Army Washington, D. C. 20314	12. REPORT DATE June 1982	
	13. NUMBER OF PAGES 90	
14. MONITORING AGENCY NAME & ADDRESS (if different from Controlling Office) U. S. Army Engineer Waterways Experiment Station Automatic Data Processing Center P. O. Box 631, Vicksburg, Miss. 39180	15. SECURITY CLASS. (of this report) Unclassified	
	15a. DECLASSIFICATION/DOWNGRADING SCHEDULE	
16. DISTRIBUTION STATEMENT (of this Report) Approved for public release; distribution unlimited.		
17. DISTRIBUTION STATEMENT (of the abstract entered in Block 20, if different from Report)		
18. SUPPLEMENTARY NOTES Available from National Technical Information Service, Springfield, Va. 22151. This report was prepared under the Computer-Aided Structural Engineering (CASE) Project. A list of published CASE reports is printed on the inside of the back cover.		
19. KEY WORDS (Continue on reverse side if necessary and identify by block number) CBEAMC (Computer program) Structural frames--Models Computer programs Structures, Theory of Mathematical models		
20. ABSTRACT (Continue on reverse side if necessary and identify by block number) This report documents a computer program--CBEAMC--for analysis of general beam-column structures supported and/or loaded by components which interact with the displacements of the beam and/or column. The report: a. Describes the general beam-column system considered and the mathema- tical model used for analysis. b. Presents the force-displacement relationships for the mathematical (Continued) →		

DD FORM 1 JAN 73 1473 EDITION OF 1 NOV 65 IS OBSOLETE

Unclassified

SECURITY CLASSIFICATION OF THIS PAGE (When Data Entered)

Unclassified

SECURITY CLASSIFICATION OF THIS PAGE(When Data Entered)

20. ABSTRACT (Continued).

model and describes the computational procedure used for solution.

c. Provides example solutions obtained with the program.

Unclassified

SECURITY CLASSIFICATION OF THIS PAGE(When Data Entered)

PREFACE

This user's guide documents a computer program called CBEAMC that can be used for analysis of general beam-column structures supported and/or loaded by components which interact with the displacements of the beams and/or columns. The work in writing the computer program and the user's guide was accomplished with funds provided to the U. S. Army Engineer Waterways Experiment Station (WES), Vicksburg, Miss., by the Civil Works Directorate, Office, Chief of Engineers, U. S. Army (OCE), under the Structural Engineering Research Program work unit of the Computer-Aided Structural Engineering (CASE) Project.

The computer program and user's guide were written by Dr. William P. Dawkins, P.E., of Stillwater, Okla., under contract with WES.

Dr. N. Radhakrishnan, Special Technical Assistant, Automatic Data Processing (ADP) Center, WES, and CASE Project Manager, coordinated and monitored the work. Messrs. H. Wayne Jones and Reed L. Mosher, Computer-Aided Design Group provided technical assistance in developing and evaluating the program. Mr. Donald L. Neumann was Chief of the ADP Center. Mr. Donald R. Dressler was the point of contact in OCE.

Directors of WES during the development of this program were COL N. P. Conover, CE, and COL T. C. Creel, CE. Technical Director was Mr. F. R. Brown.

Accession For	
NTIS GRA&I	<input checked="" type="checkbox"/>
DTIC TAB	<input type="checkbox"/>
Unannounced	<input type="checkbox"/>
Justification	
By _____	
Distribution/	
Availability Codes	
Dist	Avail and/or Special
A	



CONTENTS

	<u>Page</u>
PREFACE	1
CONVERSION FACTORS, INCH-POUND TO METRIC (SI)	
UNITS OF MEASUREMENT	4
PART I: INTRODUCTION	5
General	5
Organization of Report	5
Disclaimer	5
PART II: BEAM-COLUMN SYSTEM	6
General	6
Beam	6
Displacements	6
Applied Loads	8
Fixed Supports	8
Concentrated Linear Spring Supports	8
Distributed Linear Spring Supports	9
Concentrated Nonlinear Spring Supports	9
Distributed Nonlinear Spring Supports	9
Characteristics of Nonlinear Springs	10
PART III: FINITE ELEMENT MODEL	11
General	11
Nodes	11
Variations in System Properties	11
Elements	13
Node Equilibrium	15
Iteration	21
Effect of Node Spacing on Solution	22
PART IV: COMPUTER PROGRAM	23
General	23
Input Data	23
Global Coordinate System	23
Displacement and Load Sign Conventions	23
Nonlinear Spring Conventions	24
Concentrated Nonlinear Springs	24
Distributed Nonlinear Springs	26
Data Generations	26
Beam Cross Section Properties	26
Node Spacing Data	28
Distributed Loads	29
Distributed Linear Springs	29
Distributed Nonlinear Springs	29
Output Data	31
Echoprint of Input Data	31
Summary of Results	31
Complete Results	31
Sign Conventions for Output	32
PART V: EXAMPLE SOLUTIONS	33
General	33
Example I: Fixed End Beam	33

CONTENTS

	<u>Page</u>
Example 2: Beam on Uniform Elastic Foundation	34
Example 3: Pile Head Stiffness Matrix	34
Example 4: Anchored Retaining Wall	35
REFERENCES	36
APPENDIX A: GUIDE FOR DATA INPUT	A1
Source of Input	A1
Data Editing	A1
Input Data File Generation	A1
Data Format	A1
Sections of Input	A2
Minimum Required Data	A2
Units	A2
Predefined Data File	A3
Input Description	A5
Abbreviated Input Guide	A14
APPENDIX B: EXAMPLE SOLUTIONS	B1
Example 1	B2
Example 2	B14
Example 3	B20
Example 4	B28

CONVERSION FACTORS, INCH-POUND TO METRIC (SI)
UNITS OF MEASUREMENT

Inch-pound units of measurement used in this report can be converted to metric (SI) units as follows:

<u>Multiply</u>	<u>By</u>	<u>To Obtain</u>
feet	0.3048	metres
inches	2.54	centimetres
kips (1000 lb force)	4.448222	kilonewtons
kips (force) per foot	14.5939042	kilonewtons per metre
pounds (force)	4.448222	newtons
pound (force)-inches	0.1129848	newton-metres
pounds (force) per square inch	6.894757	kilopascals
square inches	6.4516	square centimetres

USER'S GUIDE: COMPUTER PROGRAM FOR
ANALYSIS OF BEAM-COLUMN STRUCTURES
WITH NONLINEAR SUPPORTS (CBEAMC)

PART I: INTRODUCTION

General

1. This report documents a computer program--CBEAMC--for analysis of general beam-column structures supported and/or loaded by components which interact with the displacements of the beam and/or column.*

Organization of Report

2. The remainder of this report is divided into the following parts:
- a. Part II: Describes the general beam-column system considered and the mathematical model used for analysis.
 - b. Part III: Presents the force-displacement relationships for the mathematical model and describes the computational procedure used for solution.
 - c. Part IV: Provides example solutions obtained with the program.

Disclaimer

3. The computer program described in this report has been checked to ensure that the results are accurate within the limitations of the procedures employed. However, there may be unusual situations which were not anticipated which may cause the program to produce questionable results. It is the responsibility of the user to judge the validity of the results. No responsibility is assumed by the author for the design or behavior of any structure based on results obtained with the program.

* CBEAMC is designated X0060 in the Con conversationally Oriented Real-Time Program-Generating System (CORPS) library. Three sheets entitled "PROGRAM INFORMATION" have been hand-inserted inside the front cover. The present general information on CBEAMC and describe how it can be accessed. If procedures used to access CORPS programs should change, recipients of this report will be furnished a revised version of the "PROGRAM INFORMATION."

PART II: BEAM-COLUMN SYSTEM

General

4. The general beam-column system considered for analysis is shown in Figure 1. Characteristics and assumptions employed for each of the system components are described below.

Beam

5. The following assumptions of conventional beam bending theory are employed:

- a. The beam is composed of a linearly elastic, piecewise homogeneous material with modulus of elasticity E .
- b. The beam is essentially piecewise prismatic, i.e., the cross section area A and moment of inertia I may vary along the length but do not alter the basic assumption that plane cross sections remain plane after loading.
- c. All cross sections share an initially straight, common centroidal axis; the x -axis is shown in Figure 1.
- d. All cross sections have a principal axis parallel to the y -axis, Figure 1.
- e. Deformations due to shearing strains are negligibly small.
- f. Stress concentrations at abrupt changes in cross sections, at concentrated loads or springs and at supports are negligibly small.

Displacements

6. The following assumptions regarding displacements of the system are employed:

- a. Displacements of points on the beam centroidal axis are completely defined by translations u (parallel to the x -axis), and v (parallel to the y -axis), and rotation θ about an axis perpendicular to the x - y plane.

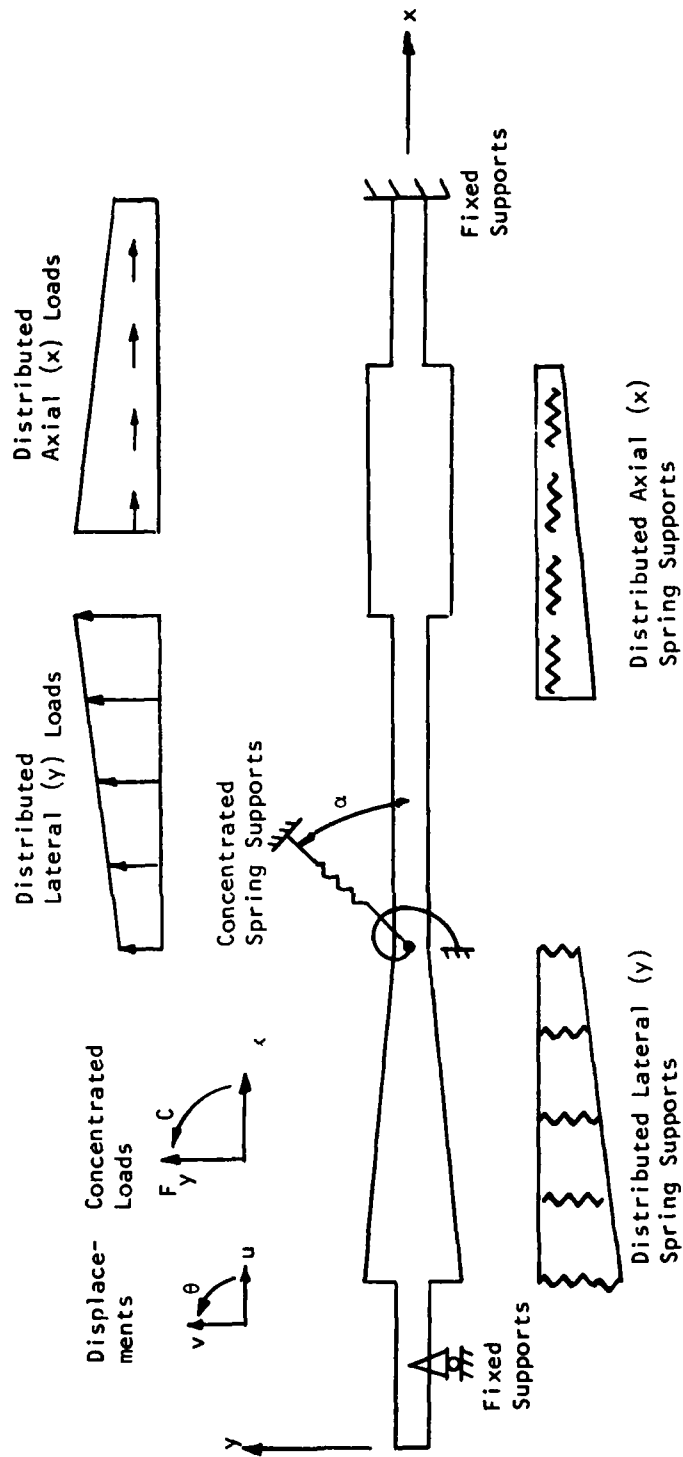

Figure 1. General Beam-Column System

- b. All displacements are small and do not alter the basic geometry of the system.
- c. Rotations θ are small enough to permit the approximations $\cos \theta = 1$ and $\sin \theta = \theta$.

Applied Loads

The following assumptions regarding external applied loads are d:

- a. Applied loads are unaffected either in magnitude, direction or point of application by the deflections of the system.
- b. Concentrated applied loads are assumed to be applied as components parallel to the x and y directions or as couples acting about axes perpendicular to the x-y plane.
- c. Distributed applied loads are assumed to act parallel to the x and y axes.

Fixed Supports

A fixed support is assumed to be an external influence which re- n a specific value (either zero or nonzero) of one or more dis- nt components at a point on the structure regardless of other

Concentrated Linear Spring Supports

Concentrated linear springs produce forces on the structure re directly proportional to the displacements of the point of ent. The following assumptions are employed:

- a. Concentrated linear translational springs may be inclined at an angle (α , Figure 1) to the axis of the beam. The re- sisting force developed in the spring is directly propor- tional to the translation of the point of attachment paral- lel to the line of action of the spring.

- b. A concentrated linear rotational spring applies a resisting couple proportional to the rotation of the point of attachment.

Distributed Linear Spring Supports

10. Distributed linear spring supports produce distributed resisting forces directly proportional to the displacements of the structure. The following assumptions are employed:

- a. Distributed linear springs resist only lateral displacements v or axial displacements u .
- b. The magnitude of the distributed resisting force depends only on the lateral displacement v or axial displacement u at any point, i.e., the Winkler hypothesis.

Concentrated Nonlinear Spring Supports

11. Concentrated nonlinear spring supports produce forces on the structure which depend on, but are not directly proportional to, the displacements of the point of attachment. The following assumptions are employed:

- a. Concentrated nonlinear translational springs may be inclined at an angle (α , Figure 1) with the axis of the beam. The resisting force developed in the spring is a function of the translation of the point of attachment parallel to the line of action of the spring.
- b. Nonlinear rotational springs are not considered.

Distributed Nonlinear Spring Supports

12. Distributed nonlinear spring supports produce distributed resisting forces which depend on, but are not directly proportional to, the displacements of the structure. The following assumptions are employed:

- a. Distributed nonlinear springs resist only lateral displacements v or axial displacements u .

- b. The magnitudes of the distributed resisting force depend only on the lateral displacement v or axial displacement u at any point, i.e., the Winkler hypothesis.

Characteristics of Nonlinear Springs

13. The force-deformation relationship for a nonlinear spring (either concentrated or distributed) is assumed to be provided as a piecewise linear curve, as shown in Figure 2. For any deformation Δ , parallel to the spring line of action, the total resisting force (concentrated or distributed) may be expressed as

$$Q \text{ (or } q) = Q_0 \text{ (or } q_0) + k\Delta \quad (1)$$

Hence, although an iterative solution is required, during any iteration a nonlinear spring may be replaced by a combination of a fixed load (Q_0 or q_0) and a linear spring with stiffness k .

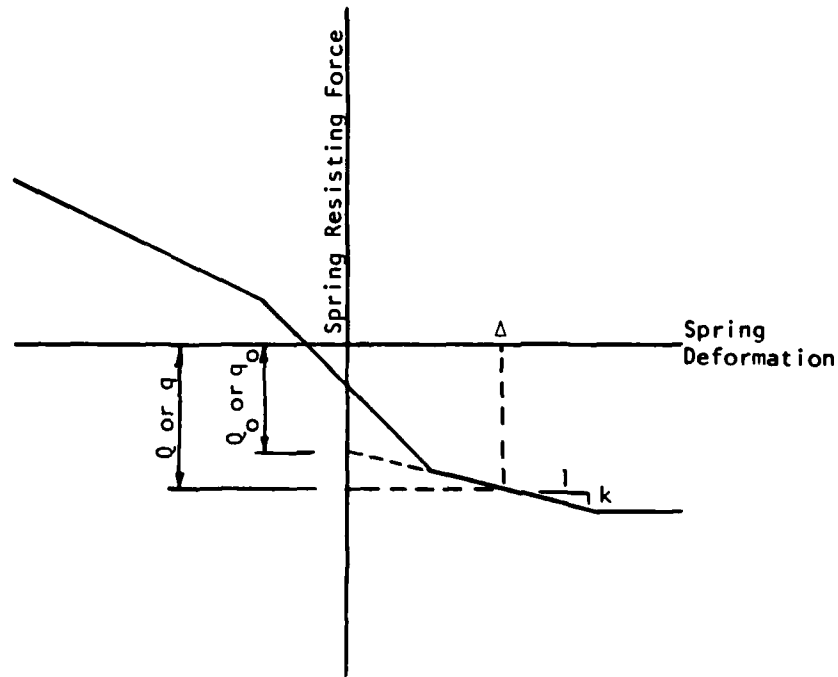

Figure 2. Characteristics of Nonlinear Springs

PART III: FINITE ELEMENT MODEL

General

14. Solutions for the general beam-column system are obtained with the finite element model described below.

Nodes

15. Because the centroidal axis of the beam is initially straight, the location of a node is completely defined by its x-coordinate. For identification in the following paragraphs, nodes are assumed to be numbered sequentially starting with node 1 at the left end of the beam, as shown in Figure 3.

16. A minimum number of nodes are dictated by the characteristics of the system:

- a. At the left and right ends of the beam.
- b. At points of change in beam properties (i.e., E, I, and/or A).
- c. At the point of application of concentrated loads.
- d. At fixed supports.
- e. At the point of application of concentrated spring supports.
- f. At the beginning and end of distributed (either axial or lateral) loads.
- g. At the beginning and end of distributed spring (either axial or lateral) supports.

17. Displacements, internal forces, and other effects are determined only at the nodes. To provide more detailed description of the variation of effects along the length, nodes may be defined at any other location on the beam. In addition, the accuracy of a solution may be affected by the number of nodes. This aspect will be discussed subsequently.

Variations in System Properties

18. The following assumptions are employed for system properties which vary along the length of the structure.

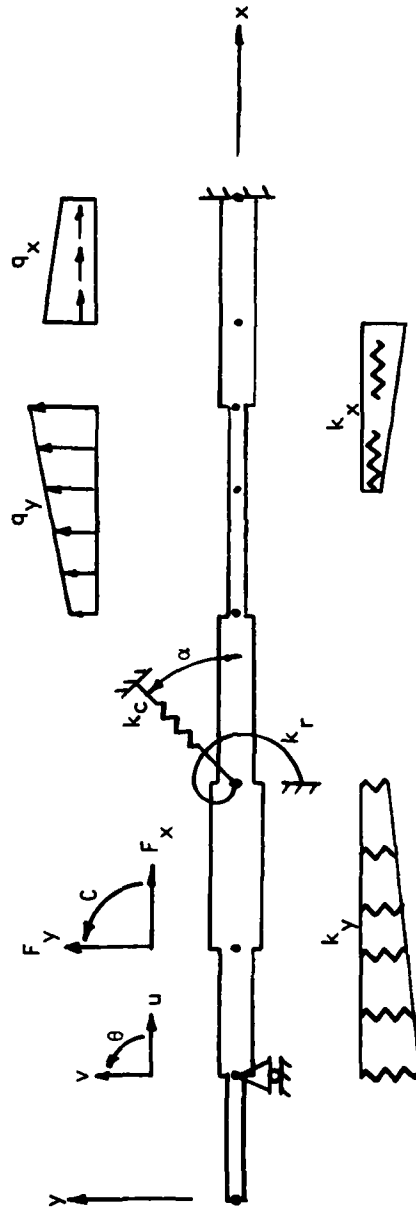

X-Coordinate	x_1	x_2	x_3	x_{i-1}	x_i	x_{i+1}	x_n
Node Number	1	2	3	$i-1$	i	$i+1$	n
Element Number	1	2	3	$i-1$	i	$n-1$	

Figure 3. Finite Element Model

- a. Beam cross section properties E, A, and I are assumed to be constant between adjacent nodes. In effect, a tapered beam is replaced by a piecewise prismatic (stepped) member. As discussed later this replacement is accomplished automatically.
- b. Distributed loads (either applied or resulting from the fixed load portion of distributed nonlinear springs) are assumed to vary linearly between adjacent nodes.
- c. Distributed spring stiffnesses (either distributed linear springs or the linear stiffness component of a distributed nonlinear spring) are assumed to vary linearly between adjacent nodes.

Elements

19. An element is defined as the portion of the beam between adjacent nodes. For reference in the following paragraphs, an element is identified by the node number at its left end, as shown in Figure 3.

20. Under the assumptions stated above, each element is characterized by modulus of elasticity E, cross section properties A and I, length h, and is subjected to distributed loads and springs, as shown in Figure 4.

21. Interaction of internal axial stress resultants with lateral deflections will affect the bending response of the element. When this effect is included, the bending resistance of the element is developed using a constant average axial stress resultant given by

$$P = \frac{AE}{h} (u_{i+1} - u_i) \quad (2)$$

22. The relationship between element end forces and end nodal displacements, obtained by procedures given in References (1), (2), and (3) is

$$f^i = [S_E^i + S_k^i] U^i + f_e^i \quad (3)$$

where

C

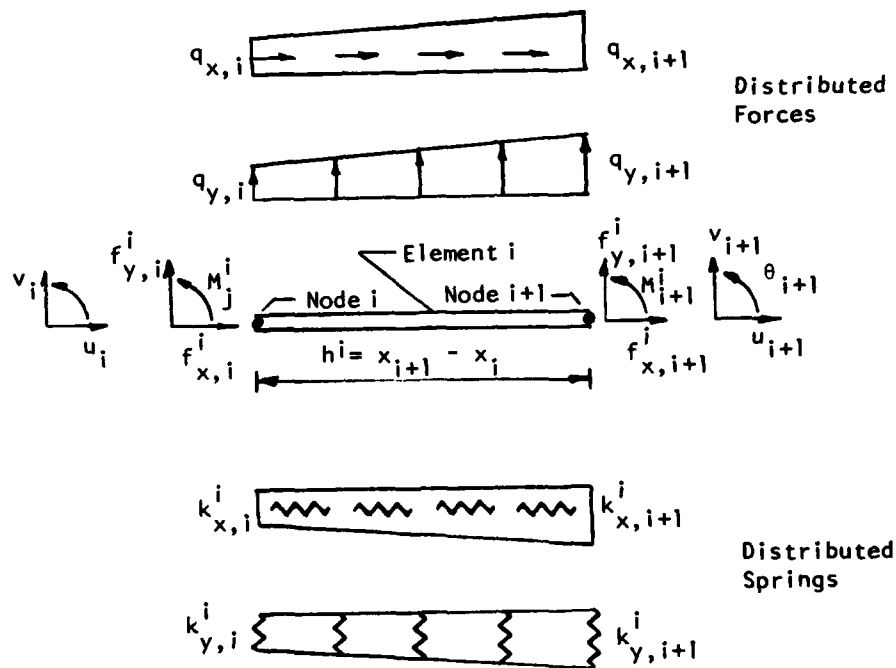

Figure 4. Typical Element

$$f^i = [f_x^i \ f_y^i \ M_i^i \ | \ f_{x,i+1}^i \ f_{y,i+1}^i \ M_{i+1}^i]^T$$

= (6x1) vector of element end forces;

S_E^i = (6x6) axial and beam bending stiffness matrix including effects of axial stress resultant on bending;

S_k^i = (6x6) stiffness matrix representing effects of distributed springs;

$$U^i = [u_i \ v_i \ \theta_i \ | \ u_{i+1} \ v_{i+1} \ \theta_{i+1}]^T$$

= (6x1) vector of end nodal displacements; and

$$f_e^i = [f_{e,x}^i \ f_{e,y}^i \ M_{e,i}^i \ | \ f_{e,x,i+1}^i \ f_{e,y,i+1}^i \ M_{e,i+1}^i]^T$$

= (6x1) vector of fixed end forces due to distributed loads.

23. Coefficients for matrices S_E^i , S_k^i , and f_e^i are given in Figures 5, 6, and 7 and Table 1.

Node Equilibrium

24. A typical node, shown in Figure 8, is subjected to:

- a. Concentrated forces $F_{x,i}$, $F_{y,i}$, and C_i , where $F_{x,i}$ and $F_{y,i}$ include both applied external concentrated loads and the fixed force component of all concentrated nonlinear springs attached to the node.
- b. One or more concentrated linear translation springs which include the linear spring components of concentrated nonlinear springs attached to the node.
- c. One or more linear rotation springs.
- d. Element end forces from elements on either side of the node.

25. Equilibrium of element i is expressed by

$$\begin{Bmatrix} f_{x,i}^{i-1} \\ f_{y,i}^{i-1} \\ m_i^{i-1} \end{Bmatrix} + \begin{Bmatrix} f_{x,i}^i \\ f_{y,i}^i \\ m_i^i \end{Bmatrix} + \Sigma \begin{bmatrix} k_{c,i} \cos^2 \alpha & k_{c,i} \sin \alpha \cos \alpha & 0 \\ k_{c,i} \sin \alpha \cos \alpha & k_{c,i} \sin^2 \alpha & 0 \\ 0 & & k_r \end{bmatrix} \begin{Bmatrix} u_i \\ v_i \\ \theta_i \end{Bmatrix}$$

or

$$f_i^{i-1} + f_i^i + (k_{c,i}) U_i = F_i \quad (4)$$

$$\begin{bmatrix}
 A & 0 & 0 & -A & 0 & 0 \\
 a_1 \frac{I}{h} & \frac{I}{h} & a_2 \frac{I}{h} & 0 & -a_1 \frac{I}{h} & 0 \\
 a_3 I & a_2 \frac{I}{h} & a_4 I & 0 & -a_2 \frac{I}{h} & a_4 I \\
 \text{SYM} & & & A & 0 & 0 \\
 & & & a_1 \frac{I}{h} & -a_2 \frac{I}{h} & a_3 I
 \end{bmatrix}$$

$$S_{E,i}^i = \frac{E}{h}$$

where: E = modulus of elasticity;
 A = cross section area;
 I = cross section moment of inertia;
 h = element length; and
 a_1 - a_4 = constants given in Table 1.

a. Explicit

$$S_{E,i}^i = \begin{bmatrix} S_{E,i,i}^i & S_{E,i,i+1}^i \\ S_{E,i+1,i}^i & S_{E,i+1,i+1}^i \end{bmatrix}$$

b. Partitioned Symbolic

Figure 5. Element Axial and Beam Bending Stiffness Matrix

$$\begin{bmatrix}
 (210 k_{x,i} + 70 k_{x,i+1}) & 0 & 0 & 70(k_{x,i} + k_{x,i+1}) & 0 & 0 \\
 (240 k_{y,i} + 72 k_{y,i+1}) & h(30 k_{y,i} + 14 k_{y,i+1}) & 0 & 54(k_{y,i} + k_{y,i+1}) & -h(14 k_{y,i} + 12 k_{y,i+1}) & 0 \\
 h^2(5 k_{y,i} + 3 k_{y,i+1}) & 0 & 0 & h(12 k_{y,i} + 14 k_{y,i+1}) & -3h^2(k_{y,i} + k_{y,i+1}) & 0 \\
 (70 k_{x,i} + 210 k_{x,i+1}) & 0 & 0 & 0 & 0 & 0 \\
 \text{SYM} & & & (72 k_{y,i} + 240 k_{y,i+1}) & -h(14 k_{y,i} + 30 k_{y,i+1}) & 0 \\
 & & & 0 & 0 & h^2(3 k_{y,i} + 5 k_{y,i+1})
 \end{bmatrix}$$

a. Explicit

$$\mathbf{S}_k^i = \begin{bmatrix} S_{k,i,i} & S_{k,i,i+1} \\ S_{k,i+1,i} & S_{k,i+1,i+1} \end{bmatrix}$$

b. Partitioned Symbolic

Figure 6. Contribution of Distributed Springs to Element Stiffness Matrix

$$f_e^i = \begin{Bmatrix} f_{ex,i}^i \\ f_{ey,i}^i \\ m_{e,i}^i \\ \text{---} \\ f_{ex,i+1}^i \\ f_{ey,i+1}^i \\ m_{e,i+1}^i \end{Bmatrix} = \frac{h}{60} \begin{Bmatrix} -(20 q_{x,i} + 10 q_{x,i+1}) \\ (b_1 q_{y,i} + b_2 q_{y,i+1}) \\ h(b_3 q_{y,i} + b_4 q_{y,i+1}) \\ \text{---} \\ -(10 q_{x,i} + 20 q_{x,i+1}) \\ (b_2 q_{y,i} + b_1 q_{y,i+1}) \\ -h(b_4 q_{y,i} + b_3 q_{y,i+1}) \end{Bmatrix}$$

where b_1, b_2, b_3, b_4
= constants given in
Table 1

a. Explicit

$$f_e^i = \begin{Bmatrix} f_{e,i}^i \\ f_{e,i+1}^i \end{Bmatrix}$$

b. Partitioned Symbolic

Figure 7. Element Fixed End Forces Due to Distributed Loads

Table 1. Constants for Element Stiffness Matrix and Fixed End Forces
(P = Axial Internal Stress Resultant)

Coefficient	P = 0		P = Compression		P = Tension	
a_1	12	$\phi^5 s / \Delta$			$\phi^5 s / \Delta$	
a_2	6	$\phi^4 (1 - c) / \Delta$			$-\phi^4 (1 - c) / \Delta$	
a_3	4	$\phi^3 (s - \phi c) / \Delta$			$\phi^3 (\phi c - s) / \Delta$	
a_4	2	$\phi^3 (\phi - s) / \Delta$			$\phi^3 (s - \phi) / \Delta$	
b_1	-21	$10[-3(4 + \phi^2)(1 - c) + \phi s(6 + 2\phi^2)] / \Delta$			$10[3(4 - \phi^2)(1 - c) + \phi s(6 - 2\phi^2)] / \Delta$	
b_2	-9	$10[3(4 - \phi^2)(1 - c) - \phi s(6 - \phi^2)] / \Delta$			$10[-3(4 + \phi^2)(1 - c) - \phi s(6 + \phi^2)] / \Delta$	
b_3	-3	$10[9\phi s - \phi^2(1 + 2c) - 12(1 - c)] / \Delta$			$10[9\phi s - \phi^2(1 + 2c) + 12(1 - c)] / \Delta$	
b_4	-2	$10[3\phi s - \phi^2(2 + c)] / \Delta$			$10[3\phi s - \phi^2(2 + c)] / \Delta$	
Δ	---	$\phi^2(2 - 2c - \phi s)$			$\phi^2(2 - 2c + \phi s)$	
ϕ	---	$\sqrt{Ph^2/EI}$			$\sqrt{Ph^2/EI}$	
s	---	$\sin(\phi)$			$\sinh(\phi)$	
c	---	$\cos(\phi)$			$\cosh(\phi)$	

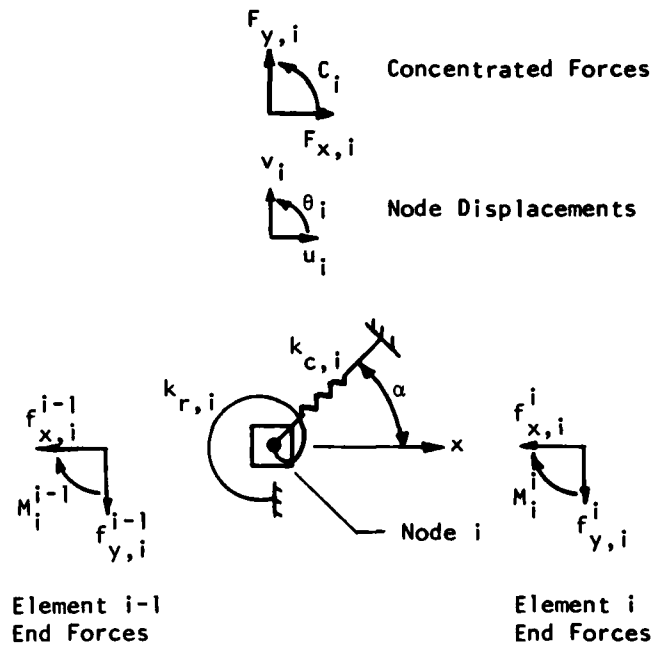

Figure 8. Typical Node

where the summation Σ extends over all concentrated springs attached to node i .

26. Substitution for end force vectors f_i^{i-1} and f_i^i in terms of element stiffness matrices using Equation (3) and Figures 5, 6, and 7 results in the following governing equation which must be satisfied at every node.

$$\begin{aligned} & [S_{E,i,i-1}^{i-1} + S_{K,i,i-1}^{i-1}] U_{i-1} \\ & + [S_{E,i,i}^{i-1} + S_{K,i,i}^{i-1} + S_{E,i,i}^i + S_{K,i,i}^i + \Sigma K_{C,i}] U_i \\ & + [S_{E,i,i+1}^i + S_{K,i,i+1}^i] U_{i+1} = F_i + f_{e,i}^{i-1} + f_{e,i}^i \quad (5) \end{aligned}$$

27. Evaluation of Equation (5) at every node in the model results in a system of simultaneous equations ($3n$ equations for a model with n nodes) which, after revision to reflect fixed supports, may be solved for nodal displacements. When nodal displacements are known, internal forces, spring forces, and reactions may be determined for the system.

Iteration

28. A single solution of the simultaneous equations produces final results for systems possessing the following characteristics:

- a. Only linear spring supports are present; and
- b. The effect of axial stress resultant on element bending stiffness is excluded; or
- c. The effect of axial stress resultant on element bending stiffness is included and axial distributed springs are absent and all concentrated translational springs are perpendicular to the beam axis.

29. All other systems require an iterative solution in order to evaluate axial stress resultants and/or fixed force-linear spring components for nonlinear springs. The iterative solution process is initiated by evaluating axial stress resultants and nonlinear spring characteristics for zero displacements. The simultaneous equations are evaluated and solved for a new estimate of system displacements. On each iteration the solution of the preceding iteration is used for evaluation of system properties. This process is continued until the results of two successive iterations differ by an acceptably small amount.

Effect of Node Spacing on Solution

- . The finite element procedure described above produces "exact" solutions for systems possessing the following characteristics:
 - a. The beam is piecewise prismatic.
 - b. Only concentrated external loads and linearly varying lateral (y) loads are present. Or if the effect of axial stress resultant on element bending stiffness is excluded, distributed axial (x) loads vary linearly.
 - c. Only concentrated springs are present and, if the effect of axial stress resultant on element bending stiffness is included, all concentrated translation springs are perpendicular to the beam axis. (Note: The accuracy of a solution including the effect of axial stress resultant in the presence of inclined translational springs may be affected by the iteration convergence tolerance but not by node spacing.)
 - d. Adjacent elements are approximately equal in length. Adjacent elements having drastically different lengths may result in significant round-off errors in the solution of simultaneous equations.
- . In all other systems the number of nodes (and elements) used in finite element model affects the accuracy of the solution. In general the number of nodes (and elements) is increased, the solution converges to the "exact" solution. There is no "rule-of-thumb" to provide the necessary number of nodes for acceptable results. It may be necessary to perform several solutions for various numbers of nodes and spacings to ensure that an adequate solution has been obtained.

PART IV: COMPUTER PROGRAM

General

32. A computer program implementing the analytical process described above has been written in the FORTRAN programming language. With minor revisions the program will be operational on a computer employing a 60 bit (~15 decimal digit) word length. For systems using fewer than 15 decimal digits it may be necessary to perform some arithmetic operations in double precision.

Input Data

33. The program has been written to generate automatically intermediate data values from a minimum of user input data. Details of required user input data are presented in the Input Guide, Appendix A. The processes and assumptions used in converting user input data to intermediate data values are described below.

Global Coordinate System

34. A horizontal beam centroidal axis (the x-axis, positive to the right) is assumed. The global y axis is positive upward. The origin of the x-y coordinate system is arbitrary. A local coordinate system associated with nonlinear springs is described later.

Displacement and Load Sign Conventions

35. Positive directions for displacements and loads are as follows:
- a. Nodal displacements u and v are positive if the node translates in the positive x and y directions, respectively.
 - b. Nodal rotation is positive if the node rotates counterclockwise.
 - c. External loads (concentrated F_x and F_y ; or distributed q_x and q_y) are positive if they act in the positive x and y directions, respectively.

- d. A concentrated applied couple (C) is positive if it tends to rotate the node counterclockwise.
- e. Concentrated or distributed linear spring stiffnesses are always positive.

Nonlinear Spring Conventions

36. As stated previously, the characteristics of nonlinear springs are assumed to be described by a piecewise linear curve giving spring resisting force as a function of spring deformation. The sign conventions assumed for each of the three types of nonlinear springs permitted by the program are as follows.

Concentrated Nonlinear Springs

37. Concentrated nonlinear springs are assumed to resist nodal translation displacement components parallel to the spring line of action. Positive resisting forces and spring deformations for concentrated springs are defined for a local x' coordinate, as shown in Figure 9. The origin of the local x' coordinate is at the point of attachment (node); the positive x' direction extends along the spring line of action away from the point of attachment. The inclination of the spring is given by the angle α between the global x -axis and the local x' axis (positive counterclockwise).

38. Spring resisting forces are positive if they act in the positive local x' direction. To illustrate, consider a spring in an initial state of compression at zero nodal displacement. The spring therefore would produce a force acting on the node in the negative x' direction (i.e., negative force), $-F_1$, at zero spring deformation, $\Delta_1 = 0$, as illustrated by point (1) in Figure 9b. If the point of attachment undergoes nodal displacements u and v to produce a positive deformation $+\Delta_2$, Figure 9a, the compression (i.e., negative spring force), $-F_2$, would increase as illustrated by point (2) in Figure 9b. Further positive deformation to Δ_3 would result in a negative resisting force, $-F_3$, as shown by point (3). If the nodal displacements produce deformation in the negative x' direction, e.g., $-\Delta_4$, the compressive (negative) force in the spring would

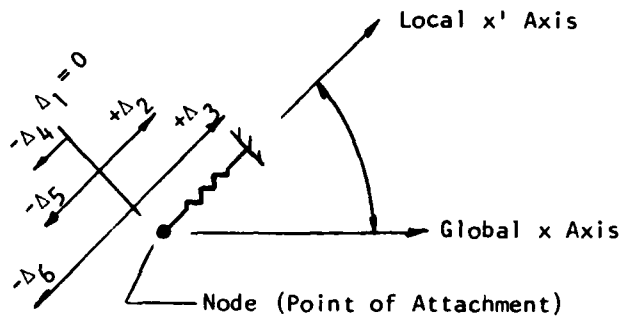

a. Concentrated Nonlinear Spring

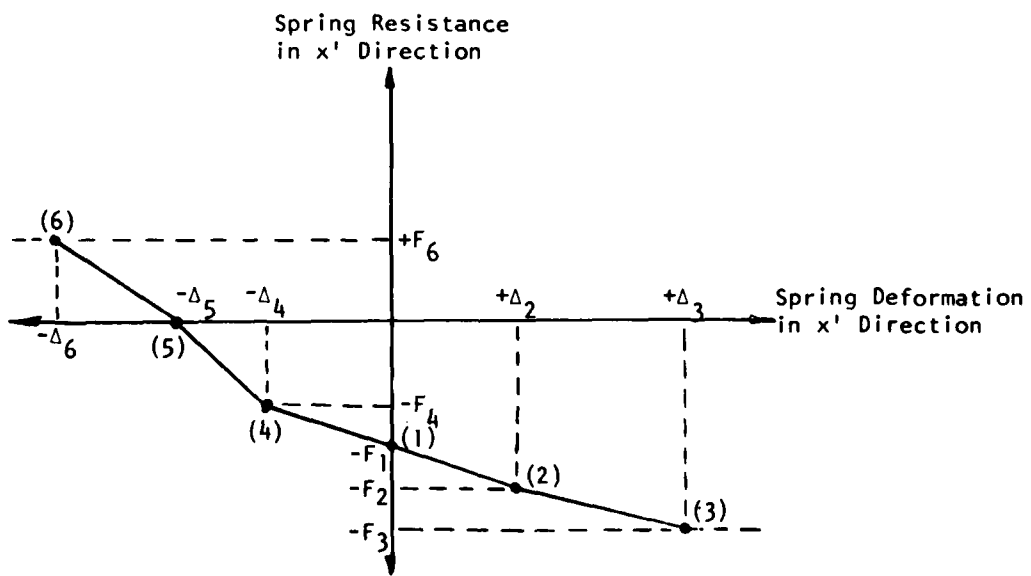

b. Resisting Force-Deformation Curve

Figure 9. Characteristics of Concentrated Nonlinear Spring

c

reduce to, $-F_4$, point (4). At some negative deformation, $-\Delta_5$, the initial compression might be totally relieved, i.e., $F_5 = 0$, as shown by point (5). Further negative deformation, $-\Delta_6$, might produce tension in the spring ($+F_6$), as illustrated by point (6). The coordinate values, Δ, F , of each point on the deformation-resistance curve are provided as input. A linear variation between input deformation-resistance coordinates is assumed.

Distributed Nonlinear Springs

39. Distributed nonlinear springs produce distributed forces proportional to the translation displacements of the nodes. The deformation of the spring is equal to and has the same sign as the nodal displacement. The distributed force produced on the beam by a distributed nonlinear spring is positive if the force acts in the positive global x or y coordinate directions. Distributed spring characteristics are assumed to be described by pairs resisting force-deformation coordinate values similar to those for concentrated springs.

Data Generation

40. Concentrated applied loads, concentrated springs and fixed supports occur at isolated points on the structure. All other data (beam properties E, A, and I, and distributed loads and springs) are distributed over a range of x-coordinates. The user is required to provide the locations (x-coordinates) at which concentrated effects occur and the terminal values (beginning and end) of distributed quantities. These define the "dictated" nodes in the model. The program also provides for defining nodes intermediate to the dictated nodes. The following paragraphs describe the procedures and assumptions used to obtain system characteristics at the intermediate nodes.

Beam Cross Section Properties

41. Beam cross section properties A and I are provided at the terminals of a distribution. Figure 10 illustrates for cross section area

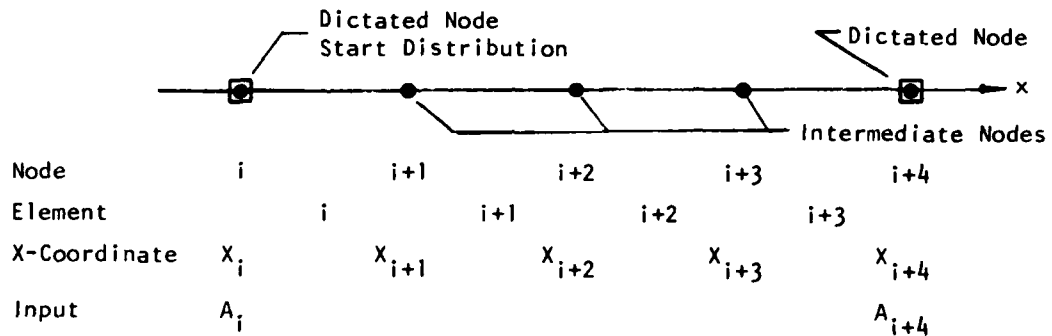

a. Notation

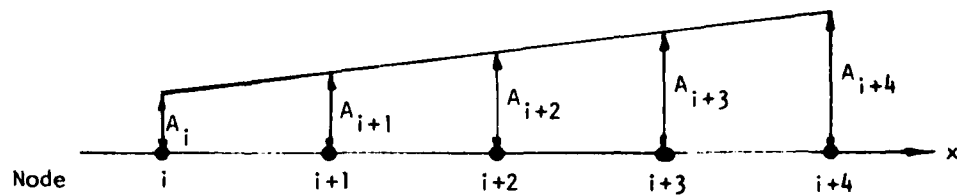

b. Assumed Linear Distribution

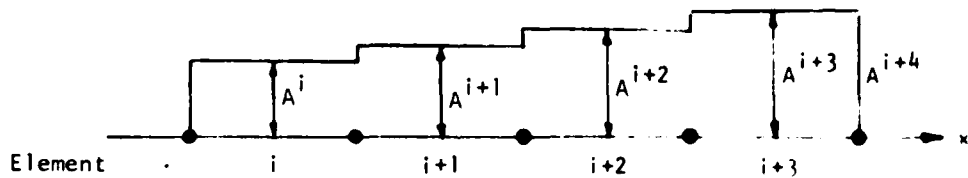

c. Piecewise Prismatic Representation

Figure 10. Distribution of Beam Cross Section Properties

the steps used to convert input data to element properties. The user has specified values of cross section area A_i and A_{i+4} at x_i and x_{i+4} , respectively, resulting in "dictated" nodes i and $i+4$. Through node spacing data (see below) intermediate nodes have been defined at $i+1$, $i+2$, and $i+3$. The initial assumption is made that cross section area varies linearly from A_i at x_i to A_{i+4} at x_{i+4} , as shown in Figure 10b, to result in values of cross section areas A_{i+1} , A_{i+2} , and A_{i+3} at x_{i+1} , x_{i+2} , and x_{i+3} , respectively. The distribution is further converted to the piecewise prismatic representation shown in Figure 10c by assigning to each element covered by the distribution a constant area equal to the average of the areas at each end of the element, e.g., $A^{i+1} = (A_{i+1} + A_{i+2})/2$. Note that E is required to be constant over the distribution.

42. Beam cross section properties data are assumed to define the extreme (left and right) ends of the beam-column system to be analyzed. Nonzero values of section properties E , A , and I must be supplied for every point on the structure between these extremes. Any other distributed or concentrated data which fall beyond these extremes are ignored by the program.

Node Spacing Data

43. Node spacing data provide for defining nodes intermediate to the "dictated" nodes. The user specifies a maximum node spacing, H_{\max} , to be used in a range of x -coordinates. For example, consider the range of x -coordinates between "dictated" nodes x_i and x_{i+4} in Figure 10a. The range of coordinates x_i to x_{i+4} will be subdivided into elements of equal length as follows. The number of elements is equal to the largest integer given by

$$n = (x_{i+4} - x_i) / H_{\max} + 0.9 \quad (6)$$

and the length of elements in this region will be

$$h = (x_{i+4} - x_i) / n \quad (7)$$

If H_{\max} is greater than or equal to $(x_{i+4} - x_i)$, then the entire region will be treated as a single element.

44. If a "dictated" node falls between the limits of a range of node spacing data, intervals to the left and right of the dictated node are treated as separate ranges for intermediate node spacing.

Distributed Loads

45. Distributed loads are assumed to vary linearly between the values at the beginning and end of the distribution provided as input.

Distributed Linear Springs

46. The program provides for variations in linear spring stiffness coefficients over an interval x_1 to x_2 given by the general expression

$$k = a + bz^c \quad (8)$$

where

k = stiffness coefficient (force/length/displacement) of distributed x or y spring at any point x_1 to x_2 ;

a = stiffness at k_1 , always positive;

b = constant with units such that bz^c has units of stiffness; b may be either positive or negative; however, only positive values of k are permitted;

z = distance measured from x_1 ; and

c = dimensionless constant.

47. For the input values x_1 , x_{i+3} , a , b , and c , the program calculates at each intermediate node the distributed spring stiffness from the general expression given in Equation (8), as illustrated in Figure 11. For analysis, the nonlinear distribution given by the general Equation (9) is replaced by the piecewise linear variation shown by the dashed lines in Figure 11.

Distributed Nonlinear Springs

48. Distributed nonlinear springs are described by resisting force-deformation curves for each end of the distribution, as illustrated in Figure 12. As stated previously, a nonlinear spring is represented by a

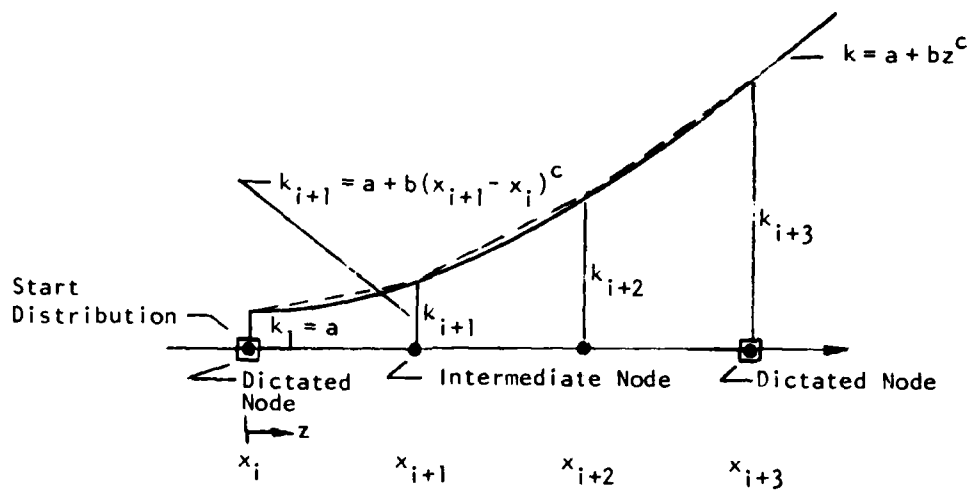

Figure 11. Distributed Linear Spring Stiffnesses

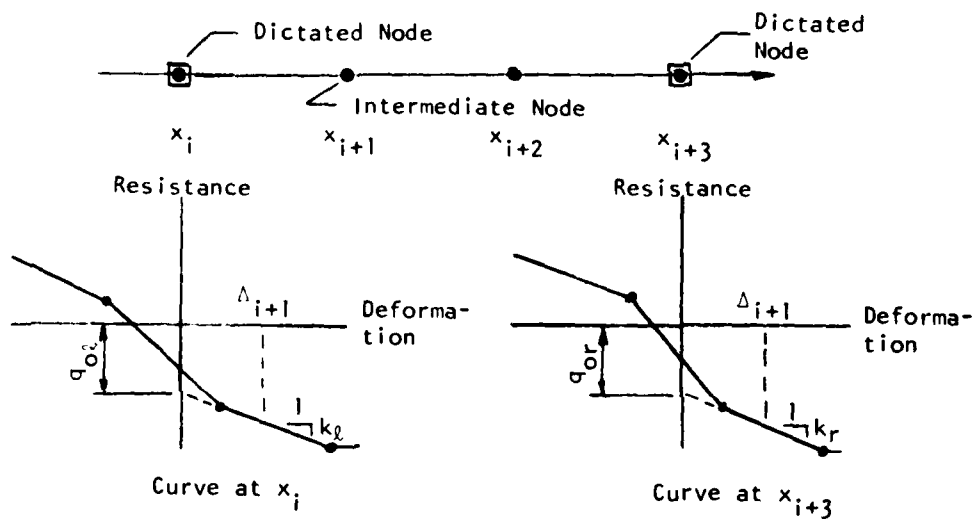

Figure 12. Distributed Nonlinear Spring

combination of a fixed force and a linear spring. The components of the nonlinear spring at intermediate nodes are obtained as follows. Consider node $i+1$ in Figure 12. The spring deformation at node $i+1$, Δ_{i+1} (either u_{i+1} or v_{i+1}) is used with the input curve at node i to obtain $q_{o,l}$ and k_l ; and with the curve at node $i+3$ to obtain $q_{o,r}$ and k_r . The values at node $i+1$ are then calculated from linear interpolation as

$$q_{o,i+1} = [q_{o,l} (x_{i+3} - x_{i+1}) + q_{o,r} (x_{i+1} - x_i)] / (x_{i+3} - x_i) \quad (9)$$

and

$$k_{i+1} = [k_l (x_{i+3} - x_{i+1}) + k_r (x_{i+1} - x_i)] / (x_{i+3} - x_i) \quad (10)$$

Output Data

49. Output data are provided in three parts. Output may be directed to the user terminal, to a data file, to both or some parts of the output may be omitted entirely.

Echoprint of Input Data

50. This section contains a tabular listing of all input data currently available to the program. This section is output at the option of the user.

Summary of Results

51. This section contains: maximum positive and maximum negative values of displacements and internal forces and the x -coordinates at which the maxima occur; reactions at fixed supports; and forces in concentrated linear and/or nonlinear springs. This section is always output to either the user terminal, to an output file, or both.

Complete Results

52. This section contains a tabulation of displacements, internal

stress resultants, and forces in distributed springs at nodes contained within a range of x-coordinates specified by the user. This section may be omitted entirely.

Sign Conventions for Output

53. Sign conventions used for output data are presented in Table 2.

Table 2. Output Sign Conventions

Quantity	Sign Convention
Translations u and v	Positive if node moves in positive x or y coordinate direction, respectively
Rotation θ	Positive if node rotates counterclockwise
Axial Internal Stress Resultant	Positive if tension
Shear Stress Resultant	Positive if shear force tends to move left end of segment of beam in positive y direction (i.e., up on left, down on right end of segment)
Bending Moment	Positive if produces compression in plus y face (top) of beam
X,Y Reactions at Fixed Supports	Positive if act in positive x and y coordinate directions, respectively
Moment Reactions at Fixed Supports	Positive if act counterclockwise on beam
Forces in Concentrated Linear Translation Springs	Positive if tension
Moment in Linear Rotation Spring	Positive if acts counterclockwise on beam
Forces in Concentrated Nonlinear Translation Springs	Sign determined according to input resisting force-deformation curve coordinates
Forces in Distributed Linear Springs	Positive if tension
Forces in Distributed Nonlinear Springs	Sign determined according to input resting force-deformation curve coordinates

PART V: EXAMPLE SOLUTIONS

General

54. Program output and supporting information demonstrating the use of the program are contained in Appendix B. Principal features of each solution are discussed below.

55. Interactive control of the program is shown with the output for Example 1.

Example 1: Fixed End Beam

56. The fixed end beam shown in Figure B1 was analyzed for a succession of loading conditions described in the input data file shown on page B3.

- a. The basic problem is described in lines 1000 through 1120 of the file. During execution, effects of axial load on bending were excluded for the solution of this part.
- b. On the first rerun, Example 1A, only the problem heading was changed to that shown on lines 1140 through 1160 of the data file. All other data remain unchanged. During execution the effects on bending due to the 40 kip* axial load were included in the solution.
- c. On subsequent reruns, lines 1170 through 1340, the axial load was increased by adding concentrated load data to each preceding data set.

57. Echoprints of input data were requested only for the first and last in the succession of problems, pages B5 and B12, respectively.

58. The summary of results was output for each problem. Because the model used to represent the beam contains only three nodes and two elements, no additional information would have been provided by a complete tabulation.

59. The deflections and forces presented are "exact" solutions for each loading. The effect of axial load on bending is to increase the deflections and bending moments. As the total axial load approaches the theoretical buckling load (3289.87 kips), deflections and moments attain

* A table of factors for converting inch-pound units of measurement to metric (SI) units is presented on page 4.

extremely large values. However, for an axial load below buckling, deflections and moments are consistent with the direction of the applied lateral load. For an axial load slightly greater than the buckling load, deflections and moments undergo a reversal in sign (i.e., are inconsistent with lateral load direction) indicating that buckling has occurred.

Example 2: Beam on Uniform Elastic Foundation

60. Accuracy of results produced by the finite element model used to represent the system shown in Figure B2 depends on node spacing. Solutions were obtained for two node spacings as indicated in the data file shown on page B15.

61. The echoprint of input data, summary of results, and the (trivial) complete results table for the first case (lines 1000 through 1140 of the input file) are shown on pages B16 and B17. Maximum lateral deflection and bending moment for the model with three nodes and two elements differ only slightly from the "exact" solution (0.19097 in. and $-1.52025E+5$, respectively).

62. Increasing the model to eleven nodes and ten elements produces results, pages B18 and B19, which are exact to four significant figures.

63. It should be emphasized that node spacing may have a more significant effect on the accuracy of the solution than is indicated by this problem. This is demonstrated in Example 3.

Example 3: Pile Head Stiffness Matrix

64. The program was used to generate the pile head stiffness matrix for the system shown in Figure B3. By definition, coefficients of the pile head stiffness matrix are the reactions generated by imposing unit values of deflection components at the pile head.

65. The problem was run using the input data file shown on page B21. Because axial load effects on bending were excluded, axial and lateral coefficients for the stiffness matrix are obtained simultaneously by imposing unit axial (x) and lateral (y) deflections at the pile head with rotation at that point equal to zero. Two solutions are presented for this case: for nodes spaced at 5 ft, and nodes spaced at 1 ft. Moment

coefficients for the pile head stiffness matrix were obtained for a 1 ft node spacing by specifying zero axial and lateral displacements and a unit rotation at the pile head.

66. Results for each case are given on pages B22 through B27. Values of stiffness coefficients obtained for the 5 ft node spacing are significantly in error. Decreasing the node spacing to 1 ft produced the pile head stiffness matrix shown below. Values shown in parentheses were obtained by another approximate method reported in Reference (4).

$$\begin{Bmatrix} F_x \\ F_y \\ M \end{Bmatrix} = \begin{bmatrix} 3.602E6 & 0 & 0 \\ & 2.077E5 & 5.424E6 \\ & (2.014E5) & (5.356E6) \\ \text{SYM} & & 2.148E8 \\ & & (2.137E8) \end{bmatrix} \begin{Bmatrix} u \\ v \\ \theta \end{Bmatrix}$$

67. Reducing the node spacing to 0.5 ft had little effect on the results.

Example 4: Anchored Retaining Wall

68. A one foot strip of the multiple anchored retaining wall described in Figure B4 was analyzed as a beam-column in which the soil and anchors were represented by nonlinear springs.

69. Procedures described in Reference (5) were used to obtain the force-displacement curves shown in Figure B5 for the soil resisting lateral (y) displacements of the system. To the writer's knowledge no procedure has been established for representing wall-soil friction interaction. The force-displacement curves shown in Figure B6 were arbitrarily selected for this effect.

70. The anchors were represented by concentrated nonlinear springs with characteristics shown in Figure B7.

71. The input data file used for solution with the program is shown on page B32. Output from the program is given on pages B33 through B38. Anchor forces are given by section II.C of the output. Soil pressures are given by the tabulation of forces in distributed nonlinear springs, section III.C of the output.

REFERENCES

- ough, R. W., and J. Penzien. Dynamics of Structures. New York: McGraw-Hill Book Company, 1975.
- emieniecki, J. S. Theory of Matrix Structural Analysis. New York: McGraw-Hill Book Company, 1968.
- enkiewicz, O. C. The Finite Element Method in Engineering Science. New York: McGraw-Hill Publishing Company Limited, 1971.
- ese, L. C., and H. Matlock. "Non-Dimensional Solutions for Laterally Loaded Piles With Soil Modulus Assumed Proportional to Depth." Proceedings, Eighth Texas Conference on Soil Mechanics and Foundation Engineering, 1956.
- liburton, T. A. "Soil Structure Interaction." Technical Publication No. 14. School of Civil Engineering, Oklahoma State University, Stillwater, Oklahoma, 1971.

APPENDIX A: GUIDE FOR DATA INPUT

Source of Input

1. Input data may be supplied from a predefined data file or from the user terminal during execution. If data are supplied from the user terminal, prompting messages are printed to indicate the amount and character of data to be entered.

Data Editing

2. When all data for a problem have been entered, the user is offered the opportunity to review an echoprint of the currently available input data and to revise any or all sections of the input data before execution is attempted. When editing during execution, each section must be entered in its entirety.

Input Data File Generation

3. After data have been entered from the terminal, either initially or after editing, the user may direct the program to write the input data to a permanent file in input data file format.

Data Format

4. All input data (whether supplied from the user terminal or from a file) are read in free field format:

- a. Data items must be separated by one or more blanks (comma separators are not permitted).
- b. Integer numbers must be of form NNNN.
- c. Real numbers may be of form
±xxxx, ±xx.xx, or ±xx.xxE+ee
- d. User responses to all requests for control by the program for alphanumeric input may be abbreviated by the first letter of the indicated word response, e.g.,
ENTER 'YES' OR 'NO'--respond Y or N
ENTER 'CONTINUE' OR 'END'--respond C or E

Carriage return responses alone will cause abnormal termination of the program.

Sections of Input

5. Input data are divided into the following sections:

- a. Heading.
- b. Beam Cross Section Properties.
- c. Node Spacing.
- d. Applied Loads.
- e. Fixed Supports.
- f. Linear Spring Supports.
- g. Nonlinear Spring Supports.
- h. Termination.

6. When data are entered from the terminal, data sections a through g may be input in any order. When data are entered from a predefined data file, the heading section a must be entered first; other sections b through g may be entered in any order.

7. When data are entered from the terminal, the user is cued for Termination. Termination for a data file is discussed later.

Minimum Required Data

8. Data sections a, b, and c are always required. At least one of sections e, f, and g is required. It is the responsibility of the user to ensure that sufficient supports (either fixed or spring supports) are provided to inhibit all rigid body motions of the system, i.e., to ensure a stable structure.

Units

9. The program recognizes the following units:

Inches Feet Pounds Kips

Default is to inches and pounds. Angular units are either degrees or radians as explained below.

10. Each data section may be entered with any combination of units for length and force as specified by the user.

Predefined Data File

11. In addition to the general format requirements given in paragraph 4, above, the following pertain to a predefined data file and to the input data description which follows:
- a. Each line must commence with a nonzero, positive line number, denoted LN below.
 - b. A line of input may require both alphanumeric and numeric data items. Alphanumeric data items are enclosed in single quotes in the following paragraphs.
 - c. A line of input may require a keyword. The acceptable abbreviation for the keyword is indicated by underlined capital letters. E.g., the acceptable abbreviation for the keyword 'LINear' is 'LIN'.
 - d. Lower case words in single quotes indicate a choice of keywords defined following.
 - e. Items designated by upper case letters and numbers without quotes indicate numeric data values. Numeric data values are either real or integer according to standard FORTRAN variable naming conventions.
 - f. Data items enclosed in brackets [] may not be required. Data items enclosed in braces { } indicate special note follows.
 - g. Input data are divided into the sections discussed in paragraph 5, above. Except for the heading, each section consists of a header line and one or more data lines. The header line serves the multiple purposes of: indicating the end of the preceding section; identifying the data section to follow; indicating whether the section is 'New' or to be 'Added' to the same section of a preceding problem (see below); and indicating the units associated with the section.
 - h. A data file may contain input data for several problems to be run in succession. On the first problem defined in the file, all data sections must be 'New'. In subsequent problem descriptions, 'New' indicates the section is to replace

that section in the preceding problem; 'Add' indicates the data are to be appended to that section in the preceding problem. A data section may be deleted from the preceding problem description by indicating 'New' on the section header line and immediately following with another section header.

i. Each section header line contains the information [{'New' or 'Add'}] and [{'units'}]. Either or both of these items may be omitted.

i(1) If [{'New' or 'Add'}] is omitted, 'New' is assumed. Omit this item on the first problem description in the file.

i(2) If 'Add' is indicated, the units for appended data must be the same as for that section in the preceding problem.

i(3) [{'units'}] must be 'Inches' or 'Feet' and 'Pounds' or 'Kips'. If data are to be appended to the preceding problem, omit this item. Data to be appended must be in the same units prescribed for that section in the preceding problem.

i(4) If [{'units'}] is omitted in the header for a 'New' section, default is to inches and pounds.

j. If data are added to a preceding section, the limitations on number of lines in the section, old plus added, must not exceed those specified in the input description below.

k. A data file must begin with a Heading. In a succession of problems, the Heading for the preceding problem may be replaced by entering the new heading at the beginning of the new problem description. Addition to a previous heading is not permitted.

l. Comment lines may be inserted in the input file by enclosing the line, following the line number, in parentheses.

Comment lines are ignored, e.g.,

1234 (THIS LINE IS IGNORED).

Input Description

12. Heading--One (1) to four (4) lines for identifying the problem
- a. Line contents
LN {'heading'}
 - b. Definition
'heading' = any alphanumeric information up to 70 characters including LN and any imbedded blanks.
 - c. Restriction: If a 'heading' line following LN begins with a combination of letters which are permissible abbreviations of any of the keywords described below, the 'heading' must begin with a single quote.
13. Beam Cross Section Properties--Two (2) to twenty-two (22) lines
- a. Header--One (1) line
 - a(1) Contents
LN 'Beam' [{'New' or 'Add'}] [{'units'}]
 - a(2) Definition
'Beam' = section title;
[{'units'}] = 'Inches' or 'Feet' and 'Pounds' or 'Kips' for 'New'; default to inches and pounds if omitted for 'New'.
 - b. Data Lines--One (1) to twenty-one (21) lines
 - b(1) Contents
LN X1 X2 E A1 S11 [A2 S12]
 - b(2) Definitions
X1 = x-coordinate at beginning of distribution;
X2 = x-coordinate at end of distribution;
E = modulus of elasticity in region X1 to X2;
A1 = cross section area at X1;
S11 = cross section moment of inertia at X1;
A2,S12 = area and moment of inertia at X2.
 - b(3) Discussion
 - (a) If A2 and S12 are omitted area and moment of inertia are assumed to be constant from X1 to X2.

- (b) If A2 and S12 are provided, area and moment of inertia are assumed to vary linearly from A1 and S11 at X1 to A2 (and S12 at X2).
- (c) When several distributions are described, the minimum of all X1 values defines the left end of the beam and the maximum of all X2 values defines the right end of the beam. There must be positive, nonzero values of modulus of elasticity, area, and moment of inertia for every x-coordinate between the ends of the beam.
- (d) If distributions are specified for overlapping regions, values within the overlap are cumulative.

14. Node Spacing--One (1) to twenty-two (22) lines

a. Header--One (1) line

a(1) Contents

LN 'NODe' [{'New' or 'Add'}] [{'units'}]

a(2) Definitions

'NODe' = section title;

[{'units'}] = 'Inches' or 'Feet' for 'New'; default to inches if omitted for 'New'.

b. Data Line--One (1) to twenty-one (21) lines

b(1) Contents

LN X1 X2 HMAX

b(2) Definitions

X1,X2 = x-coordinates at beginning and end of interval, respectively;

HMAX = maximum distance between nodes in interval X1 to X2.

c. Discussion

c(1) Intervals X1 to X2 must proceed sequentially from left to right. Overlapping intervals or gaps between intervals are not permitted.

c(2) X1 on the first line input must be less than or equal to the x-coordinate at the left end of the beam.

- c(3) X2 on the last line input must be greater than or equal to the x-coordinate at the right end of the beam.
 - c(4) Data specified beyond the ends of the beam are ignored.
 - c(5) Node spacing data must result in at least three (3) nodes (2 elements) and not more than two-hundred-one (201) nodes (200 elements) in the model.
15. Applied Loads--Zero (0) or two (2) to twenty-two (22) lines.

Entire section may be omitted

a. Header--One (1) line

a(1) Contents

LN 'Loads' [{'New' or 'Add'}] [{'units'}]

a(2) Definitions

'Loads' = section title;

{'units'} = 'Inches' or 'Feet' and 'Pounds' or 'Kips' for 'New'; default to inches and pounds if omitted.

b. Data Lines for Concentrated Loads--One (1) line for each concentrated load

b(1) Contents

LN 'Concentrated' X1 FX FY C

b(2) Definitions for concentrated loads

'Concentrated' = keyword;

X1 = x-coordinate at point of concentrated load(s);

FX,FY = magnitudes of concentrated x and y loads, respectively;

C = magnitude of concentrated couple.

c. Data Lines for Distributed Loads--One (1) line for each distribution

c(1) Contents

LN 'Distributed' 'direction' X1 Q1 X2 [Q2]

c(2) Definitions

'Distributed' = keyword;

'direction' = 'X' for axial load, or 'Y' for lateral load;

X1 = x-coordinate at start of distribution;

X2 = x-coordinate at end of distribution;

Q1 = magnitude of distributed load at X1;

[Q2] = magnitude of distributed load at X2; assumed to be equal to Q1 if omitted (i.e., uniform load).

d. Discussion

d(1) Multiple loads specified at a single x-coordinate, either concentrated or overlapping distributions are cumulative.

d(2) Data specified beyond the ends of the beam are ignored.

16. Fixed Supports--Zero (0) or two (2) to eleven (11) lines. Entire section may be omitted

a. Header--One (1) line

a(1) Contents

LN 'FIXed' [{'New' or 'Add'}] [{'units'}]

a(2) Definitions

'FIXed' = section title;

[{'units'}] = 'Inches' or 'Feet' for 'New'; default to inches if omitted.

b. Data Lines--One (1) to ten (10) lines

b(1) Contents

LN X1 {XD} {YD} {R}

b(2) Definitions

X1 = x-coordinate at point of support;

{XD} = specified X-displacement; enter 'Free' if unspecified;

{YD} = specified Y-displacement; enter 'Free' if unspecified;

{R} = specified rotation (in radians); enter 'Free' if unspecified.

c. Discussion

c(1) Multiple values of a single displacement component not permitted.

c(2) Data specified beyond the ends of the beam are ignored.

17. Linear Spring Supports--Zero (0) or two (2) to twenty-two (22) lines. Entire section may be omitted

a. Header--One (1) line

a(1) Contents

LN 'LINear' [{'New' or 'Add'}] [{'units'}]

a(2) Definitions

'LINear' = section title;

['units'] = 'Inches' or 'Feet' and 'Pounds' or 'Kips' for 'New'; default to inches and pounds if omitted.

b. Data Lines for Concentrated Linear Springs--One (1) line for each concentrated linear spring

b(1) Contents

LN 'Concentrated' XI ANGLE ST SR

b(2) Definitions

'Concentrated' = keyword;

XI = x-coordinate at point of attachment;

ANGLE = angle (in degrees) between x-axis and line of action of translation spring; measured positive counter-clockwise from x-axis;

ST = stiffness of translation spring in force per unit displacement;

SR = stiffness of rotation spring in moment per radian.

c. Data Lines for Distributed Linear Springs--One (1) line for each distribution

c(1) Contents

LN 'Distributed' 'direction' XI X2 A B C



c(2) Definitions

'Distributed' = keyword;

'direction' = 'X' for axial spring or 'Y' for lateral spring;

X1 = x-coordinate at start of distribution;

X2 = x-coordinate at end of distribution;

A,B,C = spring stiffness coefficients (see discussion below).

d. Discussion

d(1) If several concentrated linear springs are attached to a single point, effects are cumulative.

d(2) Stiffness of a distributed spring is assumed to vary according to $S = A + BZ^C$, where Z is the distance from X1. Units of A and B are force per unit length per unit displacement; C is a dimensionless constant.

d(3) Overlapping distributions result in cumulative effects in the overlap.

d(4) Data specified beyond the end of the beam are ignored.

18. Nonlinear Spring Supports--Zero (0) or four (4) to sixty-four (64) lines. Entire section may be omitted

a. Header--One (1) line

a(1) Contents

LN 'NONlinear' [{'New' or 'Add'}] [{'units'}]

a(2) Definitions

'NONlinear' = section title;

[{'units'}] = 'Inches' or 'Feet' and 'Pounds' or 'Kips'; default to inches and pounds if omitted.

b. Data Lines for Concentrated Nonlinear Springs--Three (3) lines for each concentrated spring

b(1) Line 1 Contents:

LN 'Concentrated' X1 ANGLE NPTS DMUL FMUL

Line 2 Contents:

LN DEF(1) DEF(2) . . . DEF(NPTS)

Line 3 Contents:

LN FORCE(1) FORCE(2) . . . FORCE(NPTS)

b(2) Definitions

'Concentrated' = keyword

XI = x-coordinate at point of attachment;

ANGLE = angle (in degrees) between x-axis and spring line of action; measured positive counterclockwise from positive x-direction;

NPTS = number of points on resisting force-deformation curve; minimum of two (2) points required; maximum of eight (8) points permitted;

DMUL = scale factor for curve deformation coordinate values; must be positive and nonzero;

FMUL = scale factor for curve resisting force coordinate values;

DEF() = curve deformation coordinate value; NPTS values on one line; must proceed sequentially from most negative to most positive;

FORCE() = curve resisting force coordinate value corresponding to DISP().

c. Data Lines for Distributed Nonlinear Springs--Minimum of Two (2) groups of three (3) lines for each distribution

c(1)(a) Group 1, Line 1 Contents:

LN 'Distributed' 'direction' XI NPTS DMUL FMUL

Group 1, Line 1 Contents:

LN DEF(1) DEF(2) . . . DEF(NPTS)

Group 1, Line 3 Contents:

LN FORCE(1) FORCE(2) . . . FORCE(NPTS)

c(1)(b) Definitions for Group 1:

'Distributed' = keyword indicating beginning of distribution;

'direction' = 'X' or 'Y' indicating distributed spring resists axial (x) or lateral (y) displacements;

X1 = x-coordinate at beginning of distribution;

NPTS = number of points provided on nonlinear resisting force-displacement curve at X1; minimum of two (2) points required; maximum of eight (8) points permitted;

DMUL = scale factor for curve deformation coordinate values; positive, nonzero;

FMUL = scale factor for curve resisting force coordinate values;

DEF() = deformation coordinate value; NPTS values on one line; must proceed from most negative to most positive;

FORCE() = resisting distributed force corresponding to DISP().

c(2)(a) Group 2, Line 1 Contents:

LN 'control' X2 NPTS DMUL FMUL

Group 2, Line 2 Contents:

LN DEF(1) DEF(2) . . . DEF(NPTS)

Group 2, Line 3 Contents:

LN FORCE(1) FORCE(2) . . . FORCE(NPTS)

c(2)(b) Definitions for Group 2:

'control' = 'Continue' or 'End'; 'Continue' indicates distribution continues and another set of Group 2 lines follows; 'End' indicates this is last curve in this distribution;

X2 = x-coordinate for this nonlinear curve;

NPTS, DMUL, FMUL, DEF(), FORCE() as in Group 1.

d. Discussion

- d(1) Final deformation and resisting force curve coordinates are products $DMUL \cdot DEF()$ and $FMUL \cdot FORCE()$, respectively.
- d(2) Resisting force-deformation curve must be single valued at every point.
- d(3) Resisting force-deformation curve is assumed to vary linearly between input points.
- d(4) Resisting force is assumed to be constant at first or last value provided on curve for deformations beyond the range of deformation coordinates provided.
- d(5) Several concentrated nonlinear springs may be attached a single point.
- d(6) Characteristics of distributed nonlinear springs at intermediate points on a distribution are obtained by linear interpolation between adjacent curves.
- d(7) Overlapping distributions result in cumulative effects in the overlap.
- d(8) Data specified beyond the ends of the beam are ignored.

19. Termination--One (1) line

a. Contents:

LN 'FINish' [{'Rerun' }]

b. Definitions

'FINish' = keyword indicating end of input data for a problem. Initiates data checking and solution;

[{'Rerun' }] = keyword; if omitted, program assumes this is end of data file; if included, after solution of preceding problem, program will immediately read succeeding data as input for a new problem.

Abbreviated Input Guide

Data items enclosed in brackets [] may be omitted. Braces { } enclosing data lists indicate choose one; arrow indicates default if item omitted.)

1. Heading--One (1) to four (4) lines

```
LN 'heading'  
[LN 'heading']  
[LN 'heading']  
[LN 'heading']
```

1. Beam Cross Section Properties--Two (2) to twenty-two (22) lines

a. Header--One (1) line

```
LN 'Beam' [({→'New'  
'Add'})] [({→'Inches' } {→'Pounds' })]  
'Feet' } {→'Kips' })]
```

b. Data Lines--One (1) to twenty-one (21) lines

```
LN X1 X2 E A1 S11 [A2 S12]
```

2. Node Spacing--Two (2) to twenty-two (22) lines

a. Header--One (1) line

```
LN 'NODE' [({→'New'  
'Add'})] [({→'Inches' }  
'Feet' })]
```

b. Data Lines--One (1) to twenty-one (21) lines

```
LN X1 X2 HMAX
```

3. Applied Loads--Zero (0) or two (2) to twenty-two (22) lines

a. Header--One (1) line

```
LN 'LOADS' [({→'New'  
'Add'})] [({→'Inches' } {→'Pounds' })]  
'Feet' } {→'Kips' })]
```

b. Data Lines for Concentrated Loads--One (1) line for each concentrated load

```
LN 'Concentrated' X1 FX FY C
```

c. Data Lines for Distributed Loads--One (1) line for each distribution

```
LN 'Distributed' {  
'X' } X1 Q1 X2 [Q2]  
'Y' }
```

4. Fixed Supports--Zero (0) or two (2) to eleven (11) lines

a. Header--One (1) line

```
LN 'FIXed' [({→'New'  
'Add'})] [({→'Inches' }  
'Feet' })]
```

b. Data Lines--One (1) to ten (10) lines

```
LN X1 {XD'Free'} {YD'Free'} {R'Free'}
```

25. Linear Spring Supports--Zero (0) or two (2) to twenty-two (22) lines

a. Header--One (1) line

```
LN 'LInear' [{New'Add'}] [{Inches'Feet'}]{Pounds'Kips'}
```

b. Data Lines for Concentrated Linear Springs--One (1) line for each spring

```
LN 'Concentrated' X1 ANGLE ST SR
```

c. Data Lines for Distributed Linear Springs--One (1) line for each distribution

```
LN 'Distributed' {X'Y'} X1 X2 A B C
```

26. Nonlinear Spring Supports--Zero (0), four (4), or seven (7) to (64) lines

a. Header--One (1) line

```
LN 'NONlinear' [{New'Add'}] [{Inches'Feet'}]{Pounds'Kips'}
```

b. Data Lines for Concentrated Nonlinear Springs--Three (3) lines for each spring

Line 1:

```
LN 'Concentrated' X1 ANGLE NPTS DMUL FMUL
```

Line 2:

```
LN DEF(1) DEF(2) . . . DEF(NPTS)
```

Line 3:

```
LN FORCE(1) FORCE(2) . . . FORCE(NPTS)
```

c. Data Lines for Distributed Nonlinear Springs--Minimum of two (2) groups of three (3) lines for each distribution

Group 1, Line 1:

```
LN 'Distributed' {X'Y'} X1 NPTS DMUL FMUL
```

Group 1, Line 2:

```
LN DEF(1) DEF(2) . . . DEF(NPTS)
```

Group 1, Line 3:

```
LN FORCE(1) FORCE(2) . . . FORCE(NPTS)
```

Group 2, Line 1:

```
LN {'Continue'} X2 NPTS DMUL FMUL  
LN {'End'}
```

Group 2, Line 2:

```
LN DEF(1) DEF(2) . . . DEF(NPTS)
```

Group 2, Line 3:

```
LN FORCE(1) FORCE(2) . . . FORCE(NPTS)
```

27. Termination

```
LN 'FINish' ['Rerun']
```

APPENDIX B: EXAMPLE SOLUTIONS

4

BI

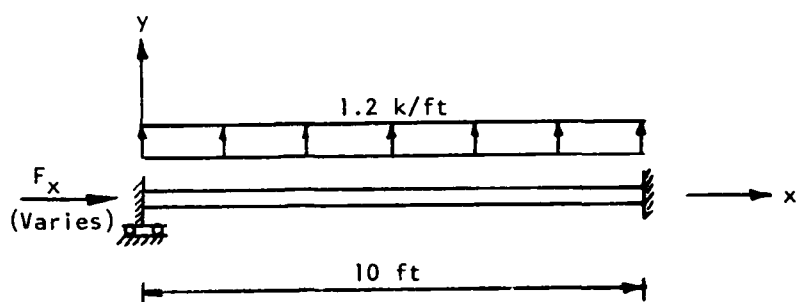

Cross Section: $E = 30 \times 10^6$ psi
 $A = 4$ sq in.
 $I = 40$ in.⁴

Figure B1. Example 1: Fixed End Beam

***** input file for example 1 *****

1000 EXAMPLE 1 -- FIXED END BEAM ANALYSIS
1010 EFFECTS OF AXIAL LOAD ON BENDING EXCLUDED
1020 BEAM
1030 0 120 30.E6 4 40
1040 NODES F
1050 -10 20 5
1060 LOADS F K
1070 D Y 0 1.2 10
1080 C 0 40 0 0
1090 FIXED F
1100 0 FREE 0 0
1110 10 0 0 0
1120 FINISH RERUN
1130 EXAMPLE 1A -- SAME AS EXAMPLE 1
1140 EXCEPT INCLUDE EFFECTS OF AXIAL LOAD ON BENDING
1150 AXIAL LOAD = 40 KIPS
1160 FINISH RERUN
1170 EXAMPLE 1B -- INCREASE AXIAL LOAD TO 2000 KIPS
1180 LOADS ADD
1190 C 0 1960 0 0
1200 FINISH RERUN
1210 EXAMPLE 1C -- INCREASE AXIAL LOAD TO 3000 KIPS
1220 LOADS ADD
1230 C 0 1000 0 0
1240 FINISH RERUN
1250 EXAMPLE 1D -- INCREASE AXIAL LOAD TO 3289 KIPS
1260 THIS AXIAL LOAD IS SLIGHTLY LESS THAN BUCKLING LOAD
1270 LOADS ADD
1280 C 0 289 0 0
1290 FINISH RERUN
1300 EXAMPLE 1E -- INCREASE AXIAL LOAD TO 3290 KIPS
1310 THIS AXIAL LOAD IS SLIGHTLY GREATER THAN BUCKLING LOAD
1320 LOADS ADD
1330 C 0 1 0 0
1340 FINISH

PROGRAM CBEAMC - ANALYSIS OF BEAM-COLUMNS WITH NONLINEAR SUPPORTS
DATE: 06/23/80 TIME: 19:56:01

ARE INPUT DATA TO BE READ FROM TERMINAL OR FILE?
ENTER 'TERMINAL' OR 'FILE'
I>F
ENTER INPUT FILE NAME (6 CHARACTERS MAXIMUM)
I>EXAMP1
INPUT COMPLETE
DO YOU WANT INPUT DATA ECHOPRINTED TO YOUR
TERMINAL, TO A FILE, TO BOTH, OR NEITHER?
ENTER 'TERMINAL', 'FILE', 'BOTH', OR 'NEITHER'
I>T

PROGRAM CBEAMC - ANALYSIS OF BEAM-COLUMNS WITH NONLINEAR SUPPORTS
DATE: 06/23/80 TIME: 19:56:43

I.--INPUT DATA

1.--HEADING

EXAMPLE 1 -- FIXED END BEAM ANALYSIS
EFFECTS OF AXIAL LOAD ON BENDING EXCLUDED

2.--BEAM CROSS SECTION DATA

X-COORDINATE		MODULUS OF ELASTICITY (PSI)	<-----SECTION PROPERTIES----->			
START (IN)	STOP (IN)		<-----START----->		<-----STOP----->	
			AREA (SQIN)	INERTIA (IN**4)	AREA (SQIN)	INERTIA (IN**4)
0.00	120.00	3.00E+07	4.00	40.00	4.00	40.00

3.--NODE SPACING DATA

X-COORDINATE		MAXIMUM NODE SPACING (FT)
START (FT)	STOP (FT)	
-10.00	20.00	5.00

4.--LOAD DATA

4.A.--CONCENTRATED LOADS

X-COORD (FT)	CONCENTRATED LOADS		
	X-LOAD (K)	Y-LOAD (K)	COUPLE (K-FT)
0.00	40.00	0.00	0.00

4.B.--DISTRIBUTED LOADS

LOAD DIRECT	<-----START----->		<-----STOP----->	
	X-COORD (FT)	LOAD (K/FT)	X-COORD (FT)	LOAD (K/FT)
Y	0.00	1.20	10.00	1.20

5.--FIXED SUPPORT DATA

SUPPORT X-COORD (FT)	SPECIFIED DISPLACEMENTS		
	X-DISP. (FT)	Y-DISP. (FT)	ROTATION (RAD)
0.00	FREE	0.00	0.00
10.00	0.00	0.00	0.00

6.--LINEAR SPRING DATA

NONE

7.--NONLINEAR SPRING DATA

NONE

DO YOU WANT TO EDIT INPUT DATA? ENTER 'YES' OR 'NO'
 I>N DO YOU WANT TO CONTINUE SOLUTION? ENTER 'YES' OR 'NO'
 I>Y DO YOU WANT AXIAL FORCE EFFECTS ON BENDING STIFFNESS INCLUDED
 IN THE SOLUTION? ENTER 'YES' OR 'NO'
 I>N

SOLUTION COMPLETE
 DO YOU WANT RESULTS WRITTEN TO YOUR TERMINAL,
 TO A FILE, OR BOTH?
 ENTER 'TERMINAL', 'FILE', OR 'BOTH'
 I>T ENTER DESIRED OUTPUT UNITS
 'INCHES' OR 'FEET', AND 'POUNDS' OR 'KIPS', OR 'DEFAULT'
 I>D

PROGRAM CBEAMC - ANALYSIS OF BEAM-COLUMNS WITH NONLINEAR SUPPORTS
 DATE: 06/23/80 TIME: 19:57:14

II.--SUMMARY OF RESULTS

II.A.--HEADING
 EXAMPLE 1 -- FIXED END BEAM ANALYSIS
 EFFECTS OF AXIAL LOAD ON BENDING EXCLUDED

II.B.--MAXIMA

	MAXIMUM POSITIVE	X-COORD (IN)	MAXIMUM NEGATIVE	X-COORD (IN)
AXIAL DISPLACEMENT (IN) :	4.000E-02	0.00	0.	0.00
LATERAL DISPLACEMENT (IN):	4.500E-02	60.00	0.	0.00
ROTATION (RAD) :	0.	0.00	0.	0.00
AXIAL FORCE (P) :	0.	0.00	-4.000E+04	0.00
SHEAR (P) :	6.000E+03	120.00	-6.000E+03	0.00
BENDING MOMENT (P-IN) :	1.200E+05	0.00	-6.000E+04	60.00

II.C.--REACTIONS AT FIXED SUPPORTS

X-COORD (IN)	X-REACTION (P)	Y-REACTION (P)	MOM-REACTION (P-IN)
0.00	0.	-6.00E+03	-1.20E+05
120.00	-4.00E+04	-6.00E+03	1.20E+05

ENTER ONE OF FOLLOWING TO OBTAIN COMPLETE TABULATION OF RESULTS:
 'ALL', OR RANGE OF X-COORDINATES IN INCHES , OR 'NONE', OR 'HELP'
 I>N

DO YOU WANT OUTPUT WITH DIFFERENT UNITS? ENTER 'YES' OR 'NO'
 I>N

OUTPUT COMPLETE
 INPUT COMPLETE
 DO YOU WANT INPUT DATA ECHOPRINTED TO YOUR
 TERMINAL, TO A FILE, TO BOTH, OR NEITHER?
 ENTER 'TERMINAL', 'FILE', 'BOTH', OR 'NEITHER'
 I>N
 DO YOU WANT TO EDIT INPUT DATA? ENTER 'YES' OR 'NO'
 I>N
 DO YOU WANT TO CONTINUE SOLUTION? ENTER 'YES' OR 'NO'
 I>Y
 DO YOU WANT AXIAL FORCE EFFECTS ON BENDING STIFFNESS INCLUDED
 IN THE SOLUTION? ENTER 'YES' OR 'NO'
 I>Y

 SOLUTION COMPLETE
 DO YOU WANT RESULTS WRITTEN TO YOUR TERMINAL,
 TO A FILE, OR BOTH?
 ENTER 'TERMINAL', 'FILE', OR 'BOTH'
 I>T
 ENTER DESIRED OUTPUT UNITS
 'INCHES' OR 'FEET', AND 'POUNDS' OR 'KIPS', OR 'DEFAULT'
 I>D

PROGRAM CBEAMC - ANALYSIS OF BEAM-COLUMNS WITH NONLINEAR SUPPORTS
 DATE: 06/23/80 TIME: 19:58:01

II.--SUMMARY OF RESULTS

II.A.--HEADING
 EXAMPLE 1A -- SAME AS EXAMPLE 1
 EXCEPT INCLUDE EFFECTS OF AXIAL LOAD ON BENDING
 AXIAL LOAD = 40 KIPS

II.B.--MAXIMA

	MAXIMUM POSITIVE	X-COORD (IN)	MAXIMUM NEGATIVE	X-COORD (IN)
AXIAL DISPLACEMENT (IN) :	4.000E-02	0.00	0.	0.00
LATERAL DISPLACEMENT (IN):	4.555E-02	60.00	0.	0.00
ROTATION (RAD) :	0.	0.00	0.	0.00
AXIAL FORCE (P) :	0.	0.00	-4.000E+04	60.00
SHEAR (P) :	4.000E+03	120.00	-6.000E+03	0.00
BENDING MOMENT (P-IN) :	1.210E+05	0.00	-6.085E+04	60.00

II.C.--REACTIONS AT FIXED SUPPORTS

X-COORD (IN)	X-REACTION (P)	Y-REACTION (P)	MOM-REACTION (P-IN)
0.00	0.	-6.00E+03	-1.21E+05
120.00	-4.00E+04	-6.00E+03	1.21E+05

ENTER ONE OF FOLLOWING TO OBTAIN COMPLETE TABULATION OF RESULTS:
 'ALL', OR RANGE OF X-COORDINATES IN INCHES , OR 'NONE', OR 'HELP'
 I>N

DO YOU WANT OUTPUT WITH DIFFERENT UNITS? ENTER 'YES' OR 'NO'
 I>N

OUTPUT COMPLETE
 INPUT COMPLETE
 DO YOU WANT INPUT DATA ECHOPRINTED TO YOUR
 TERMINAL, TO A FILE, TO BOTH, OR NEITHER?
 ENTER 'TERMINAL', 'FILE', 'BOTH', OR 'NEITHER'
 I>N
 DO YOU WANT TO EDIT INPUT DATA? ENTER 'YES' OR 'NO'
 I>N
 DO YOU WANT TO CONTINUE SOLUTION? ENTER 'YES' OR 'NO'
 I>Y
 DO YOU WANT AXIAL FORCE EFFECTS ON BENDING STIFFNESS INCLUDED
 IN THE SOLUTION? ENTER 'YES' OR 'NO'
 I>Y

SOLUTION COMPLETE
 DO YOU WANT RESULTS WRITTEN TO YOUR TERMINAL,
 TO A FILE, OR BOTH?
 ENTER 'TERMINAL', 'FILE', OR 'BOTH'
 I>T
 ENTER DESIRED OUTPUT UNITS
 'INCHES' OR 'FEET', AND 'POUNDS' OR 'KIPS', OR 'DEFAULT'
 I>D

PROGRAM CBEAMC - ANALYSIS OF BEAM-COLUMNS WITH NONLINEAR SUPPORTS
 DATE: 06/23/80 TIME: 19:58:48

II.--SUMMARY OF RESULTS

II.A.--HEADING
 EXAMPLE 1B -- INCREASE AXIAL LOAD TO 2000 KIPS

II.B.--MAXIMA

	MAXIMUM POSITIVE	X-COORD (IN)	MAXIMUM NEGATIVE	X-COORD (IN)
AXIAL DISPLACEMENT (IN) :	2.000E+00	0.00	0.	0.00
LATERAL DISPLACEMENT (IN):	1.138E-01	60.00	0.	0.00
ROTATION (RAD) :	0.	0.00	0.	0.00
AXIAL FORCE (P) :	0.	0.00	-2.000E+06	0.00
SHEAR (P) :	6.000E+03	120.00	-6.000E+03	0.00
BENDING MOMENT (P-IN) :	2.373E+05	0.00	-1.703E+05	60.00

II.C.--REACTIONS AT FIXED SUPPORTS

X-COORD (IN)	X-REACTION (P)	Y-REACTION (P)	MOM-REACTION (P-IN)
0.00	0.	-6.00E+03	-2.37E+05
120.00	-2.00E+06	-6.00E+03	2.37E+05

ENTER ONE OF FOLLOWING TO OBTAIN COMPLETE TABULATION OF RESULTS:
 'ALL', OR RANGE OF X-COORDINATES IN INCHES , OR 'NONE', OR 'HELP'
 I>N

DO YOU WANT OUTPUT WITH DIFFERENT UNITS? ENTER 'YES' OR 'NO'
 I>N

OUTPUT COMPLETE
 INPUT COMPLETE
 DO YOU WANT INPUT DATA ECHOPRINTED TO YOUR
 TERMINAL, TO A FILE, TO BOTH, OR NEITHER?
 ENTER 'TERMINAL', 'FILE', 'BOTH', OR 'NEITHER'
 I>N
 DO YOU WANT TO EDIT INPUT DATA? ENTER 'YES' OR 'NO'
 I>N
 DO YOU WANT TO CONTINUE SOLUTION? ENTER 'YES' OR 'NO'
 I>Y
 DO YOU WANT AXIAL FORCE EFFECTS ON BENDING STIFFNESS INCLUDED
 IN THE SOLUTION? ENTER 'YES' OR 'NO'
 I>Y

SOLUTION COMPLETE
 DO YOU WANT RESULTS WRITTEN TO YOUR TERMINAL,
 TO A FILE, OR BOTH?
 ENTER 'TERMINAL', 'FILE', OR 'BOTH'
 I>T
 ENTER DESIRED OUTPUT UNITS
 'INCHES' OR 'FEET', AND 'POUNDS' OR 'KIPS', OR 'DEFAULT'
 I>D

PROGRAM CBEAMC - ANALYSIS OF BEAM-COLUMNS WITH NONLINEAR SUPPORTS
 DATE: 06/23/80 TIME: 19:59:34

II.--SUMMARY OF RESULTS

II.A.--HEADING
 EXAMPLE 1C -- INCREASE AXIAL LOAD TO 3000 KIPS

II.B.--MAXIMA

	MAXIMUM POSITIVE	X-COORD (IN)	MAXIMUM NEGATIVE	X-COORD (IN)
AXIAL DISPLACEMENT (IN) :	3.000E+00	0.00	0.	0.00
LATERAL DISPLACEMENT (IN):	5.041E-01	60.00	0.	0.00
ROTATION (RAD) :	0.	0.00	0.	0.00
AXIAL FORCE (P) :	0.	0.00	-3.000E+06	0.00
SHEAR (P) :	6.000E+03	120.00	-6.000E+03	0.00
BENDING MOMENT (P-IN) :	8.818E+05	0.00	-8.103E+05	60.00

II.C.--REACTIONS AT FIXED SUPPORTS

Y-COORD (IN)	X-REACTION (P)	Y-REACTION (P)	MOM-REACTION (P-IN)
0.00	0.	-6.00E+03	-8.82E+05
120.00	-3.00E+06	-6.00E+03	8.82E+05

ENTER ONE OF FOLLOWING TO OBTAIN COMPLETE TABULATION OF RESULTS:
 'ALL', OR RANGE OF X-COORDINATES IN INCHES , OR 'NONE', OR 'HELP'
 I>N
 DO YOU WANT OUTPUT WITH DIFFERENT UNITS? ENTER 'YES' OR 'NO'
 I>N

OUTPUT COMPLETE
 INPUT COMPLETE
 DO YOU WANT INPUT DATA ECHOPRINTED TO YOUR
 TERMINAL, TO A FILE, TO BOTH, OR NEITHER?
 ENTER 'TERMINAL', 'FILE', 'BOTH', OR 'NEITHER'
 I>N
 DO YOU WANT TO EDIT INPUT DATA? ENTER 'YES' OR 'NO'
 I>N
 DO YOU WANT TO CONTINUE SOLUTION? ENTER 'YES' OR 'NO'
 I>Y
 DO YOU WANT AXIAL FORCE EFFECTS ON BENDING STIFFNESS INCLUDED
 IN THE SOLUTION? ENTER 'YES' OR 'NO'
 I>Y

SOLUTION COMPLETE
 DO YOU WANT RESULTS WRITTEN TO YOUR TERMINAL,
 TO A FILE, OR BOTH?
 ENTER 'TERMINAL', 'FILE', OR 'BOTH'
 I>T
 ENTER DESIRED OUTPUT UNITS
 'INCHES' OR 'FEET', AND 'POUNDS' OR 'KIPS', OR 'DEFAULT'
 I>D

PROGRAM CBEAMC - ANALYSIS OF BEAM-COLUMNS WITH NONLINEAR SUPPORTS
 DATE: 06/23/80 TIME: 20:00:22

II.--SUMMARY OF RESULTS

II.A.--HEADING
 EXAMPLE 1D -- INCREASE AXIAL LOAD TO 3289 KIPS
 THIS AXIAL LOAD IS SLIGHTLY LESS THAN BUCKLING LOAD

II.B.--MAXIMA

	MAXIMUM POSITIVE	X-COORD (IN)	MAXIMUM NEGATIVE	X-COORD (IN)
AXIAL DISPLACEMENT (IN) :	3.289E+00	0.00	0.	0.00
LATERAL DISPLACEMENT (IN):	1.681E+02	60.00	0.	0.00
ROTATION (RAD) :	0.	0.00	0.	0.00
AXIAL FORCE (P) :	0.	0.00	-3.289E+06	0.00
SHEAR (P) :	6.000E+03	120.00	-6.000E+03	0.00
BENDING MOMENT (P-IN) :	2.765E+08	0.00	-2.764E+08	60.00

II.C.--REACTIONS AT FIXED SUPPORTS

X-COORD (IN)	X-REACTION (P)	Y-REACTION (P)	MOM-REACTION (P-IN)
0.00	0.	-6.00E+03	-2.77E+08
120.00	-3.29E+06	-6.00E+03	2.77E+08

ENTER ONE OF FOLLOWING TO OBTAIN COMPLETE TABULATION OF RESULTS:
 'ALL', OR RANGE OF X-COORDINATES IN INCHES , OR 'NONE', OR 'HELP'
 I>N
 DO YOU WANT OUTPUT WITH DIFFERENT UNITS? ENTER 'YES' OR 'NO'
 I>N

OUTPUT COMPLETE
INPUT COMPLETE
DO YOU WANT INPUT DATA ECHOPRINTED TO YOUR
TERMINAL, TO A FILE, TO BOTH, OR NEITHER?
ENTER 'TERMINAL', 'FILE', 'BOTH', OR 'NEITHER'
I>

IC - ANALYSIS OF BEAM-COLUMNS WITH NONLINEAR SUPPORTS
IO TIME: 20:00:47

IA

INCREASE AXIAL LOAD TO 3290 KIPS
LOAD IS SLIGHTLY GREATER THAN BUCKLING LOAD

SECTION DATA

MODULUS OF ELASTICITY (PSI)	<-----SECTION PROPERTIES----->			
	<-----START----->		<-----STOP----->	
	AREA (SQIN)	INERTIA (IN**4)	AREA (SQIN)	INERTIA (IN**4)
3.00E+07	4.00	40.00	4.00	40.00

LOADING DATA

MAXIMUM NODE STOP (FT)	SPACING (FT)
20.00	5.00

DISTRIBUTED LOADS

DORD FT)	CONCENTRATED LOADS		
	X-LOAD (K)	Y-LOAD (K)	COUPLE (K-FT)
.00	40.00	0.00	0.00
.00	1960.00	0.00	0.00
.00	1000.00	0.00	0.00
.00	289.00	0.00	0.00
.00	1.00	0.00	0.00

DISTRIBUTED LOADS

EFFECT	<-----START----->		<-----STOP----->	
	X-COORD (FT)	LOAD (K/FT)	X-COORD (FT)	LOAD (K/FT)
1	0.00	1.20	10.00	1.20

SUPPORT DATA

SPECIFIED DISPLACEMENTS		
X-DISP. (FT)	Y-DISP. (FT)	ROTATION (RAD)
FREE	0.00	0.00
0.00	0.00	0.00

LOADING DATA

SPRING DATA

DO YOU WANT TO EDIT INPUT DATA? ENTER 'YES' OR 'NO'
 I>N
 DO YOU WANT TO CONTINUE SOLUTION? ENTER 'YES' OR 'NO'
 I>Y
 DO YOU WANT AXIAL FORCE EFFECTS ON BENDING STIFFNESS INCLUDED
 IN THE SOLUTION? ENTER 'YES' OR 'NO'
 I>Y

SOLUTION COMPLETE
 DO YOU WANT RESULTS WRITTEN TO YOUR TERMINAL,
 TO A FILE, OR BOTH?
 ENTER 'TERMINAL', 'FILE', OR 'BOTH'
 I>T
 ENTER DESIRED OUTPUT UNITS
 'INCHES' OR 'FEET', AND 'POUNDS' OR 'KIPS', OR 'DEFAULT'
 I>D

PROGRAM CBEAMC - ANALYSIS OF BEAM-COLUMNS WITH NONLINEAR SUPPORTS
 DATE: 06/23/80 TIME: 20:01:12

II.--SUMMARY OF RESULTS

II.A.--HEADING
 EXAMPLE 1E INCREASE AXIAL LOAD TO 3290 KIPS
 THIS AXIAL LOAD IS SLIGHTLY GREATER THAN BUCKLING LOAD

II.B.--MAXIMA

	MAXIMUM POSITIVE	X-COORD (IN)	MAXIMUM NEGATIVE	X-COORD (IN)
AXIAL DISPLACEMENT (IN) :	3.290E+00	0.00	0.	0.00
LATERAL DISPLACEMENT (IN):	0.	0.00	-1.106E+03	60.00
ROTATION (RAD) :	0.	0.00	0.	0.00
AXIAL FORCE (P) :	0.	0.00	-3.290E+06	0.00
SHEAR (P) :	6.000E+03	120.00	-6.000E+03	0.00
BENDING MOMENT (P-IN) :	1.820E+09	60.00	-1.820E+09	0.00

II.C.--REACTIONS AT FIXED SUPPORTS

X-COORD (IN)	X-REACTION (P)	Y-REACTION (P)	MOM-REACTION (P-IN)
0.00	0.	-6.00E+03	1.82E+09
120.00	-3.29E+06	-6.00E+03	-1.82E+09

ENTER ONE OF FOLLOWING TO OBTAIN COMPLETE TABULATION OF RESULTS:
 'ALL', OR RANGE OF X-COORDINATES IN INCHES , OR 'NONE', OR 'HELP'
 I>N

DO YOU WANT OUTPUT WITH DIFFERENT UNITS? ENTER 'YES' OR 'NO'
 I>N
 OUTPUT COMPLETE
 DO YOU WANT TO EDIT INPUT DATA FOR THE PROBLEM
 JUST COMPLETED? ENTER 'YES' OR 'NO'
 I>N
 DO YOU WANT TO MAKE ANOTHER RUN? ENTER 'YES' OR 'NO'
 I>N
 ***** NORMAL TERMINATION *****

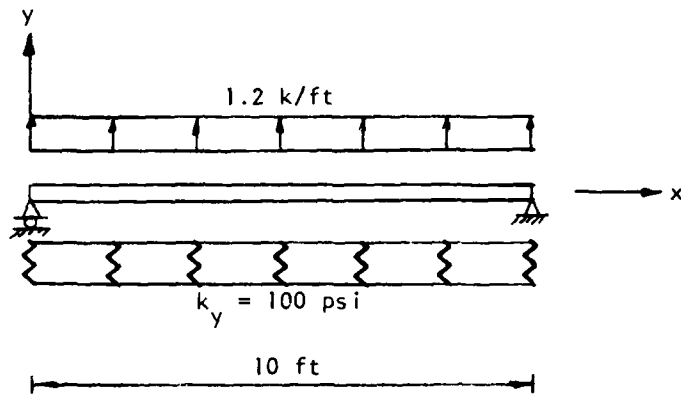

Cross Section: $E = 30 \times 10^6$ psi
 $A = 4$ sq in.
 $I = 40$ in.⁴

Figure B2. Example 2: Beam on Uniform Elastic Support

***** input file for example 2 *****

```
1000 EXAMPLE 2 -- SIMPLE BEAM ON UNIFORM ELASTIC FOUNDATION
1010 ILLUSTRATE EFFECT OF NODE SPACING ON SOLUTION
1020 'NODES AT 5 FT.
1030 BEAM
1040 0 120 30.E6 4 40
1050 NODES F
1060 0 10 5
1070 LOADS F K
1080 D Y 0 1.2 10
1090 FIXED F
1100 0 FREE 0 FREE
1110 10 0 0 FREE
1120 LINEAR
1130 D Y 0 120 100 0 0
1140 FINISH RERUN
1150 EXAMPLE 2A -- SAME AS EXAMPLE 2 EXCEPT NODES AT 1.25 FT.
1160 NODES N F
1170 0 10 1.25
1180 FINISH
```

I.--INPUT DATA

1.--HEADING

EXAMPLE 2 -- SIMPLE BEAM ON UNIFORM ELASTIC FOUNDATION
 ILLUSTRATE EFFECT OF NODE SPACING ON SOLUTION
 'NODES AT 5 FT.

2.--BEAM CROSS SECTION DATA

X-COORDINATE		MODULUS OF ELASTICITY (PSI)	<-----SECTION PROPERTIES----->			
START (IN)	STOP (IN)		<-----START----->		<-----STOP----->	
			AREA (SQIN)	INERTIA (IN**4)	AREA (SQIN)	INERTIA (IN**4)
0.00	120.00	3.00E+07	4.00	40.00	4.00	40.00

3.--NODE SPACING DATA

X-COORDINATE		MAXIMUM NODE SPACING (FT)
START (FT)	STOP (FT)	
0.00	10.00	5.00

4.--LOAD DATA

4.A.--CONCENTRATED LOADS
 NONE

4.B.--DISTRIBUTED LOADS

LOAD DIRECT	<-----START----->		<-----STOP----->	
	X-COORD (FT)	LOAD (K/FT)	X-COORD (FT)	LOAD (K/FT)
Y	0.00	1.20	10.00	1.20

5.--FIXED SUPPORT DATA

SUPPORT X-COORD (FT)	SPECIFIED DISPLACEMENTS		
	X-DISP. (FT)	Y-DISP. (FT)	ROTATION (RAD)
0.00	FREE	0.00	FREE
10.00	0.00	0.00	FREE

6.--LINEAR SPRING DATA

6.A.--CONCENTRATED LINEAR SPRINGS
 NONE

6.B.--DISTRIBUTED LINEAR SPRINGS

SPRING DIRECTION	X-COORD		SPRING STIFFNESS COEFFICIENTS		
	START (IN)	STOP (IN)	A (P/I/I)	B (P/I/I)	C
Y	0.00	120.00	100.00	0.00	0.00

7.--NONLINEAR SPRING DATA

NONE

PROGRAM CBEAMC - ANALYSIS OF BEAM-COLUMNS WITH NONLINEAR SUPPORTS
 DATE: 06/23/80 TIME: 20:22:44

II.--SUMMARY OF RESULTS

II.A.--HEADING
 EXAMPLE 2 -- SIMPLE BEAM ON UNIFORM ELASTIC FOUNDATION
 ILLUSTRATE EFFECT OF NODE SPACING ON SOLUTION
 'NODES AT 5 FT.

II.B.--MAXIMA

	MAXIMUM POSITIVE	X-COORD (IN)	MAXIMUM NEGATIVE	X-COORD (IN)
AXIAL DISPLACEMENT (IN) :	0.	0.00	0.	0.00
LATERAL DISPLACEMENT (IN):	1.912E-01	60.00	0.	0.00
ROTATION (RAD) :	5.116E-03	0.00	-5.116E-03	120.00
AXIAL FORCE (P) :	0.	0.00	0.	0.00
SHEAR (P) :	5.273E+03	120.00	-5.273E+03	0.00
BENDING MOMENT (P-IN) :	0.	0.00	-1.522E+05	60.00

II.C.--REACTIONS AT FIXED SUPPORTS

X-COORD (IN)	X-REACTION (P)	Y-REACTION (P)	MOM-REACTION (P-IN)
0.00	0.	-5.27E+03	0.
120.00	0.	-5.27E+03	0.

PROGRAM CBEAMC - ANALYSIS OF BEAM-COLUMNS WITH NONLINEAR SUPPORTS
 DATE: 06/23/80 TIME: 20:22:44

III.--COMPLETE RESULTS

III.A.--HEADING
 EXAMPLE 2 -- SIMPLE BEAM ON UNIFORM ELASTIC FOUNDATION
 ILLUSTRATE EFFECT OF NODE SPACING ON SOLUTION
 'NODES AT 5 FT.

III.B.--DISPLACEMENTS AND INTERNAL FORCES

X-COORD (IN)	<-----DISPLACEMENTS----->			<-----INTERNAL FORCES----->		
	AXIAL (IN)	LATERAL (IN)	ROTATION (RAD)	AXIAL (P)	SHEAR (P)	MOMENT (P-IN)
0.00	0.	0.	5.116E-03	0.	-5.273E+03	0.
60.00	0.	1.912E-01	0.	0.	0.	-1.522E+05
120.00	0.	0.	-5.116E-03	0.	5.273E+03	0.

III.C.--FORCES IN DISTRIBUTED LINEAR SPRINGS
 DISTRIBUTED SPRING FORCES

X-COORD (IN)	AXIAL (P/IN)	LATERAL (P/IN)
0.00	0.	0.
60.00	0.	-1.912E+01
120.00	0.	0.

PROGRAM CBEAMC - ANALYSIS OF BEAM-COLUMNS WITH NONLINEAR SUPPORTS
 DATE: 06/23/80 TIME: 20:23:28

II.--SUMMARY OF RESULTS

II.A.--HEADING

EXAMPLE 2A -- SAME AS EXAMPLE 2 EXCEPT NODES AT 1.25 FT.

II.B.--MAXIMA

	MAXIMUM POSITIVE	X-COORD (IN)	MAXIMUM NEGATIVE	X-COORD (IN)
AXIAL DISPLACEMENT (IN) :	0.	0.00	0.	0.00
LATERAL DISPLACEMENT (IN):	1.910E-01	60.00	0.	0.00
ROTATION (RAD) :	5.109E-03	0.00	-5.109E-03	120.00
AXIAL FORCE (P) :	0.	0.00	0.	0.00
SHEAR (P) :	5.266E+03	120.00	-5.266E+03	0.00
BENDING MOMENT (P-IN) :	0.	0.00	-1.520E+05	60.00

II.C.--REACTIONS AT FIXED SUPPORTS

X-COORD (IN)	X-REACTION (P)	Y-REACTION (P)	MOM-REACTION (P-IN)
0.00	0.	-5.27E+03	0.
120.00	0.	-5.27E+03	0.

III.--COMPLETE RESULTS

III.A.--HEADING
 EXAMPLE 2A -- SAME AS EXAMPLE 2 EXCEPT NODES AT 1.25 FT.

III.B.--DISPLACEMENTS AND INTERNAL FORCES

X-COORD (IN)	<-----DISPLACEMENTS----->			<-----INTERNAL FORCES----->		
	AXIAL (IN)	LATERAL (IN)	ROTATION (RAD)	AXIAL (P)	SHEAR (P)	MOMENT (P-IN)
0.00	0.	0.	5.109E-03	0.	-5.266E+03	0.
15.00	0.	7.434E-02	4.661E-03	0.	-3.823E+03	-6.802E+04
30.00	0.	1.362E-01	3.495E-03	0.	-2.483E+03	-1.152E+05
45.00	0.	1.769E-01	1.862E-03	0.	-1.221E+03	-1.429E+05
60.00	0.	1.910E-01	0.	0.	0.	-1.520E+05
75.00	0.	1.769E-01	-1.862E-03	0.	1.221E+03	-1.429E+05
90.00	0.	1.362E-01	-3.495E-03	0.	2.483E+03	-1.152E+05
105.00	0.	7.434E-02	-4.661E-03	0.	3.823E+03	-6.802E+04
120.00	0.	0.	-5.109E-03	0.	5.266E+03	0.

III.C.--FORCES IN DISTRIBUTED LINEAR SPRINGS
 DISTRIBUTED SPRING FORCES

X-COORD (IN)	AXIAL (P/IN)	LATERAL (P/IN)
0.00	0.	0.
15.00	0.	-7.434E+00
30.00	0.	-1.362E+01
45.00	0.	-1.769E+01
60.00	0.	-1.910E+01
75.00	0.	-1.769E+01
90.00	0.	-1.362E+01
105.00	0.	-7.434E+00
120.00	0.	0.

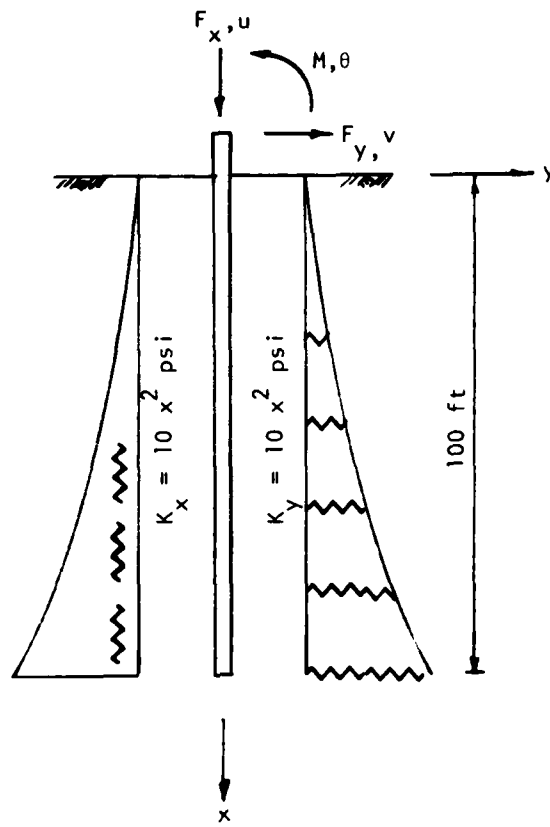

Cross Section: $E = 4.3 \times 10^6$ psi
 $A = 100$ sq in.
 $I = 833.33$ in.⁴

Figure B3. Example 3: System for Pile Head Stiffness Matrix

***** input file for example 3 *****

1000 EXAMPLE 3 -- FILE STIFFNESS MATRIX
1010 AXIAL FORCE EFFECTS OF BENDING EXCLUDED
1020 'NODES AT 5FT.
1030 AXIAL AND LATERAL TERMS
1040 BEAM
1050 0 1200 4.3E6 100 833.33
1060 NODES F
1070 0 100 5
1080 FIXED 1
1090 0 1 1 0
1100 LINEAR
1110 D Y 0 1200 0 10 2
1120 D X 0 1200 0 10 2
1130 FINISH RERUN
1140 EXAMPLE 3 -- CONTINUED
1150 AXIAL AND LATERAL TERMS
1160 'NODES AT 1 FT.
1170 NODES NEW F
1180 0 100 1
1190 FINISH RERUN
1200 EXAMPLE 3 -- CONTINUED
1210 MOMENT TERMS
1220 FIXED NEW
1230 0 0 0 1
1240 FINISH

1.--INPUT DATA

1.--HEADING

EXAMPLE 3 -- PILE STIFFNESS MATRIX
 AXIAL FORCE EFFECTS ON BENDING EXCLUDED
 'NODES AT 5 FT.
 AXIAL AND LATERAL TERMS

2.--BEAM CROSS SECTION DATA

<--COORDINATE		MODULUS OF	<-----SECTION PROPERTIES----->			
START	STOP	ELASTICITY	<----START----->		<-----STOP----->	
(IN)	(IN)	(PSI)	AREA	INERTIA	AREA	INERTIA
			(SQIN)	(IN**4)	(SQIN)	(IN**4)
0.00	1200.00	4.30E+06	100.00	833.33	100.00	833.33

3.--NODE SPACING DATA

X-COORDINATE		MAXIMUM NODE
START	STOP	
(FT)	(FT)	SPACING
0.00	100.00	5.00

4.--LOAD DATA

NONE

5.--FIXED SUPPORT DATA

SUPPORT	X-COORD	SPECIFIED DISPLACEMENTS		
		X-DISP.	Y-DISP.	ROTATION
(IN)	(IN)	(IN)	(IN)	(RAD)
0.00		1.00	1.00	0.00

6.--LINEAR SPRING DATA

6.A.--CONCENTRATED LINEAR SPRINGS

NONE

6.B.--DISTRIBUTED LINEAR SPRINGS

SPRING	X-COORD		SPRING STIFFNESS COEFFICIENTS			
	DIRECTION	START	STOP	A	B	C
		(IN)	(IN)	(P/I/I)	(P/I/I)	
Y		0.00	1200.00	0.00	10.00	2.00
X		0.00	1200.00	0.00	10.00	2.00

7.--NONLINEAR SPRING DATA

NONE

PROGRAM CBEAMC - ANALYSIS OF BEAM-COLUMNS WITH NONLINEAR SUPPORTS
 DATE: 06/24/80 TIME: 14:02:02

II.--SUMMARY OF RESULTS

II.A.--HEADING
 EXAMPLE 3 -- FILE STIFFNESS MATRIX
 AXIAL FORCE EFFECTS OF BENDING EXCLUDED
 'NODES AT 5FT.
 AXIAL AND LATERAL TERMS

II.B.--MAXIMA

	MAXIMUM POSITIVE	X-COORD (IN)	MAXIMUM NEGATIVE	X-COORD (IN)
AXIAL DISPLACEMENT (IN) :	1.000E+00	0.00	-8.297E-06	300.00
LATERAL DISPLACEMENT (IN):	1.000E+00	0.00	-1.547E-04	180.00
ROTATION (RAD) :	3.749E-05	120.00	-6.680E-03	60.00
AXIAL FORCE (P) :	2.234E+02	300.00	-3.892E+06	0.00
SHEAR (P) :	3.537E+05	0.00	-5.108E+04	60.00
BENDING MOMENT (P-IN) :	1.690E+06	60.00	-7.331E+06	0.00

II.C.--REACTIONS AT FIXED SUPPORTS

X-COORD (IN)	X-REACTION (P)	Y-REACTION (P)	MOM-REACTION (P-IN)
0.00	3.89E+06	3.54E+05	7.33E+06

PROGRAM CBEAMC - ANALYSIS OF BEAM-COLUMNS WITH NONLINEAR SUPPORTS
 DATE: 06/24/80 TIME: 14:02:02

III.--COMPLETE RESULTS

III.A.--HEADING
 EXAMPLE 3 -- PILE STIFFNESS MATRIX
 AXIAL FORCE EFFECTS OF BENDING EXCLUDED
 'NODES AT 5FT.
 AXIAL AND LATERAL TERMS

III.B.--DISPLACEMENTS AND INTERNAL FORCES

X-COORD (IN)	DISPLACEMENTS			INTERNAL FORCES		
	AXIAL (IN)	LATERAL (IN)	ROTATION (RAD)	AXIAL (P)	SHEAR (P)	MOMENT (P-IN)
0.00	1.000E+00	1.000E+00	0.	-3.892E+06	3.537E+05	-7.371E+06
60.00	4.944E-01	4.959E-02	-6.680E-03	-3.176E+06	-5.108E+04	1.690E+06
120.00	1.580E-01	7.693E-04	3.749E-05	-1.596E+06	4.434E+03	-5.210E+06

III.C.--FORCES IN DISTRIBUTED LINEAR SPRINGS

DISTRIBUTED SPRING FORCES

X-COORD (IN)	AXIAL (P/IN)	LATERAL (P/IN)
0.00	0.	0.
60.00	-1.780E+04	-1.785E+03
120.00	-2.276E+04	-1.108E+02

II.--SUMMARY OF RESULTS

II.A.--HEADING
 EXAMPLE 3 -- CONTINUED
 AXIAL AND LATERAL TERMS
 NODES AT 1 FT.

II.B.--MAXIMA

	MAXIMUM POSITIVE	X-COORD (IN)	MAXIMUM NEGATIVE	X-COORD (IN)
AXIAL DISPLACEMENT (IN) :	1.000E+00	0.00	0.	0.00
LATERAL DISPLACEMENT (IN):	1.000E+00	0.00	-1.716E-02	96.00
ROTATION (RAD) :	6.306E-04	108.00	-2.012E-02	24.00
AXIAL FORCE (P) :	0.	0.00	-3.602E+06	0.00
SHEAR (P) :	2.077E+05	0.00	-4.836E+04	72.00
BENDING MOMENT (P-IN) :	1.709E+06	60.00	-5.424E+06	0.00

II.C.--REACTIONS AT FIXED SUPPORTS

X-COORD (IN)	X-REACTION (P)	Y-REACTION (P)	MOM-REACTION (P-IN)
0.00	3.60E+06	2.08E+05	5.42E+06

III.--COMPLETE RESULTS

III.A.--HEADING
 EXAMPLE 3 -- CONTINUED
 AXIAL AND LATERAL TERMS
 'NODES AT 1 FT.

III.B.--DISPLACEMENTS AND INTERNAL FORCES

X-COORD (IN)	<-----DISPLACEMENTS----->			<-----INTERNAL FORCES----->		
	AXIAL (IN)	LATERAL (IN)	ROTATION (RAD)	AXIAL (F)	SHEAR (F)	MOMENT (F-IN)
0.00	1.000E+00	1.000E+00	0.	-9.649E+06	2.077E+05	-5.424E+06
12.00	7.350E-01	9.076E-01	-1.402E-02	-9.285E+06	1.994E+05	-2.966E+06
24.00	4.903E-01	6.953E-01	-2.012E-02	-7.998E+06	1.655E+05	-7.442E+05
36.00	2.893E-01	4.511E-01	-1.967E-02	-5.868E+06	1.029E+05	8.879E+05
48.00	1.473E-01	2.398E-01	-1.511E-02	-3.575E+06	3.139E+04	1.689E+06
60.00	6.295E-02	9.371E-02	-9.233E-03	-1.763E+06	-2.371E+04	1.709E+06
72.00	2.167E-02	1.465E-02	-4.205E-03	-6.788E+05	-4.836E+04	1.245E+06
84.00	5.628E-03	-1.476E-02	-1.026E-03	-1.913E+05	-4.545E+04	6.602E+05
96.00	9.701E-04	-1.716E-02	3.740E-04	-3.470E+04	-2.845E+04	2.104E+05
108.00	7.709E-05	-1.036E-02	6.306E-04	-2.797E+03	-1.106E+04	-2.207E+04
120.00	-1.836E-06	-3.864E-03	4.187E-04	6.417E+01	-4.502E+02	-8.321E+04

III.C.--FORCES IN DISTRIBUTED LINEAR SPRINGS
 DISTRIBUTED SPRING FORCES

X-COORD (IN)	AXIAL (F/IN)	LATERAL (F/IN)
0.00	0.	0.
12.00	-1.058E+03	-1.307E+03
24.00	-2.824E+03	-4.005E+03
36.00	-3.749E+03	-5.847E+03
48.00	-3.395E+03	-5.525E+03
60.00	-2.266E+03	-3.373E+03
72.00	-1.123E+03	-7.596E+02
84.00	-3.971E+02	1.042E+03
96.00	-8.940E+01	1.582E+03
108.00	-8.991E+00	1.208E+03
120.00	2.644E-01	5.564E+02

CREAMC - ANALYSIS OF BEAM-COLUMNS WITH NONLINEAR SUPPORTS
 05/24/80 TIME: 14:03:43

SUMMARY OF RESULTS

---HEADING
 FILE 3 -- CONTINUED
 UNIT TERMS

---MAXIMA

	MAXIMUM POSITIVE	X-COORD (IN)	MAXIMUM NEGATIVE	X-COORD (IN)
DISPLACEMENT (IN) :	0.	0.00	0.	0.00
W DISPLACEMENT (IN):	1.021E+01	24.00	-2.083E-01	108.00
DM (RAD) :	1.000E+00	0.00	-2.501E-01	48.00
FORCE (P) :	0.	0.00	0.	0.00
MF :	5.424E+06	0.00	-7.242E+05	84.00
B MOMENT (P-IN) :	2.380E+07	72.00	-2.148E+08	0.00

---REACTIONS AT FIXED SUPPORTS

X-COORD (IN)	X-REACTION (P)	Y-REACTION (P)	MOM-REACTION (P-IN)
0.00	0.	5.42E+06	2.15E+08

III.--COMPLETE RESULTS

III.A.--HEADING
 EXAMPLE 3 -- CONTINUED
 MOMENT TERMS

III.B.--DISPLACEMENTS AND INTERNAL FORCES

X-COORD (IN)	<-----DISPLACEMENTS----->			<-----INTERNAL FORCES----->		
	AXIAL (IN)	LATERAL (IN)	ROTATION (RAD)	AXIAL (P)	SHEAR (P)	MOMENT (P-IN)
0.00	0.	0.	1.000E+00	0.	5.424E+06	-2.148E+08
12.00	0.	8.121E+00	3.897E-01	0.	5.372E+06	-1.498E+08
24.00	0.	1.021E+01	-5.985E-03	0.	4.950E+06	-8.732E+07
36.00	0.	8.767E+00	-2.050E-01	0.	3.873E+06	-3.372E+07
48.00	0.	5.911E+00	-2.501E-01	0.	2.307E+06	3.630E+06
60.00	0.	3.136E+00	-2.024E-01	0.	7.573E+05	2.173E+07
72.00	0.	1.179E+00	-1.226E-01	0.	-3.067E+05	2.380E+07
84.00	0.	1.494E-01	-5.290E-02	0.	-7.242E+05	1.700E+07
96.00	0.	-2.027E-01	-1.062E-02	0.	-6.495E+05	8.407E+06
108.00	0.	-2.083E-01	6.225E-03	0.	-3.709E+05	2.220E+06
120.00	0.	-1.132E-01	8.053E-03	0.	-1.192E+05	-6.218E+05

III.C.--FORCES IN DISTRIBUTED LINEAR SPRINGS

X-COORD (IN)	DISTRIBUTED SPRING FORCES	
	AXIAL (P/IN)	LATERAL (P/IN)
0.00	0.	0.
12.00	0.	-1.169E+04
24.00	0.	-5.883E+04
36.00	0.	-1.136E+05
48.00	0.	-1.362E+05
60.00	0.	-1.129E+05
72.00	0.	-6.113E+04
84.00	0.	-1.054E+04
96.00	0.	1.868E+04
108.00	0.	2.430E+04
120.00	0.	1.630E+04

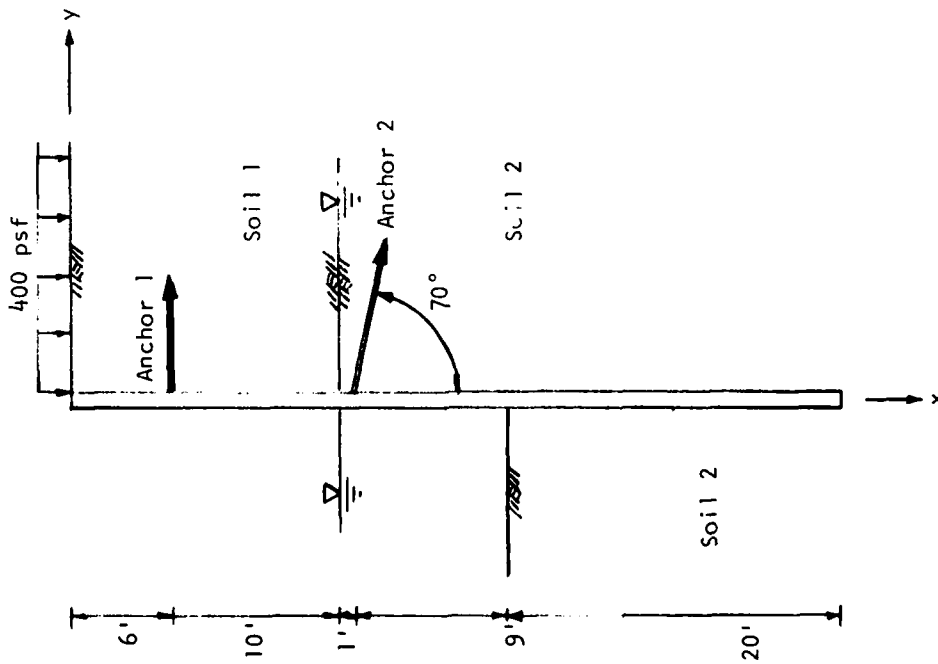

Beam: PZ 38 Sheet Pile
 $E = 29 \times 10^6$ psi
 $A = 11.2$ sq in./ft of wall
 $I = 280.8$ in.⁴/ft of wall

	Soil 1	Soil 2
Unit Weight	115 pcf	62.5 pcf (submerged)
Internal Friction	30°	0
Wall Friction	17°*	0
Cohesion	0	1000 psf
At Rest, k_0	0.5	1.0
Soil Modulus	8 pci	50 pci
Interaction Dist.	6 ft	10 ft

*Axial effects only.

	Anchor 1	Anchor 2
E (psi)	29×10^6	29×10^6
A (sq in./ft of wall)	0.16	0.2
Effective Length (ft)	25	30

Figure B4. Example 4: Multiple Anchored Retaining Wall

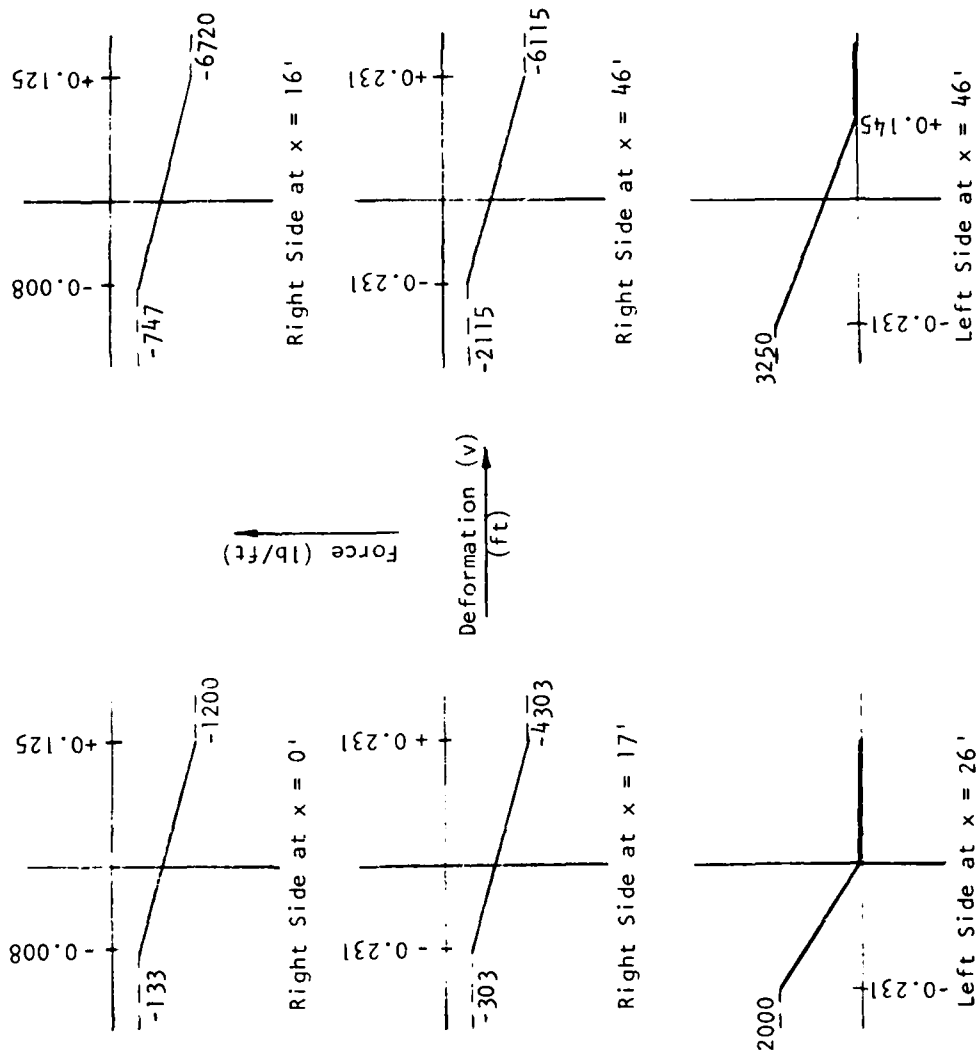

Figure 85. Force-Deformation (curves for Lateral (y) Soil Resistance

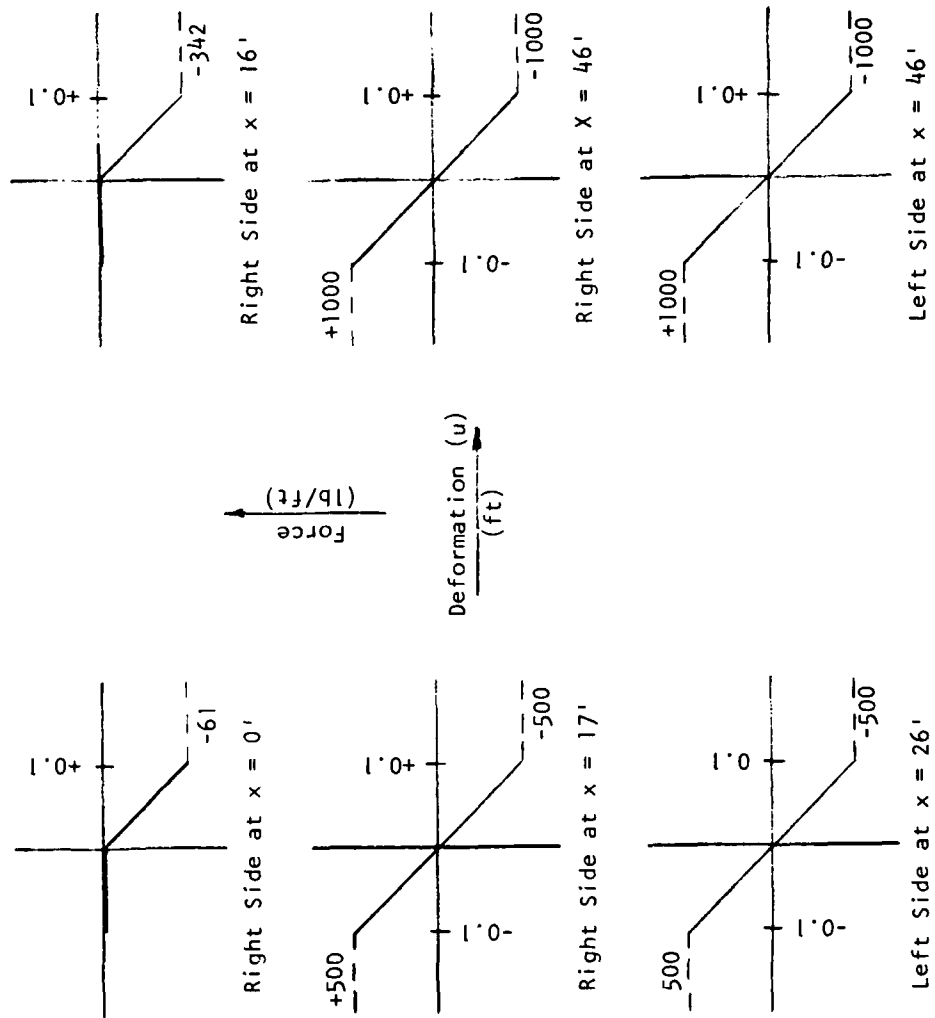
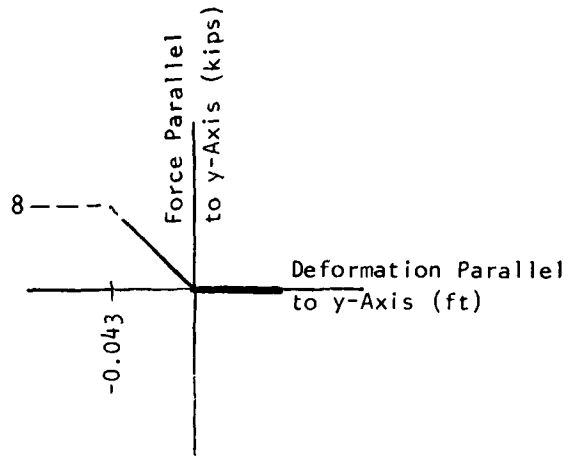
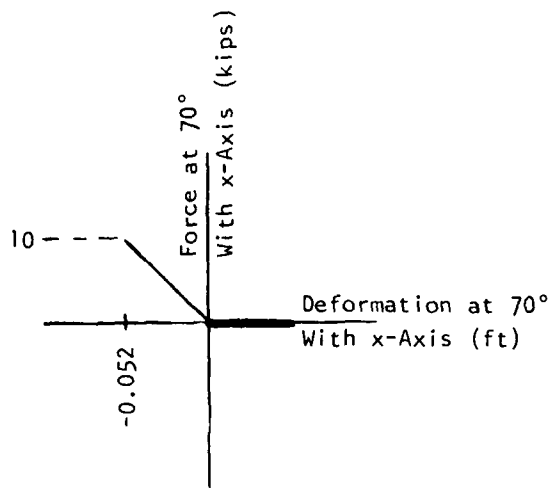

Figure B6. Force-Deformation Curves for Axial (x) Soil Resistance



Anchor at $x = 6$ ft



Anchor at $x = 17$ ft

Figure B.7. Force-Deformation Curves for Anchors

***** input file for example 4 *****

1000 EXAMPLE 4 -- MULTIPLE ANCHORED RETAINING WALL
1010 EFFECTS OF AXIAL FORCE ON BENDING EXCLUDED
1020 TENSION-ONLY ANCHORS
1030 BEAM
1040 (PZ 38 SHEET PILE)
1050 0 552 29.E6 11.2 280.8
1060 NODES F
1070 0 50 1
1080 NONLINEAR F P
1090 (LATERAL SPRINGS FOR RIGHTSIDE SOIL)
1100 D Y 0 2 1 1
1110 -0.008 0.125
1120 -133 -1200
1130 C 16 2 1 1
1140 -0.008 0.125
1150 -747 -6720
1160 C 17 2 1 1
1170 -0.231 0.231
1180 -303 -4303
1190 E 46 2 1 1
1200 -0.231 0.231
1210 -2115 -6115
1220 (LATERAL SPRINGS FOR LEFTSIDE SOIL)
1230 D Y 26 2 1 1
1240 -0.231 0.231
1250 2000 0
1260 E 46 2 1 1
1270 -0.231 0.145
1280 3250 0
1290 (AXIAL SPRINGS FOR RIGHTSIDE SOIL)
1300 D X 0 2 1 1
1310 0 0.1
1320 0 -61
1330 C 16 2 1 1
1340 0 0.1
1350 0 -342
1360 C 17 2 1 1
1370 -0.1 0.1
1380 500 -500
1390 E 46 2 1 1
1400 -0.1 0.1
1410 1000 -1000
1420 (AXIAL SPRINGS FOR LEFT SIDE SOIL)
1430 D X 26 2 1 1
1440 -0.1 0.1
1450 500 -500
1460 E 46 2 1 1
1470 -0.1 0.1
1480 1000 -1000
1490 (ANCHORS)
1500 C 6 90 2 1 1.E3
1510 -0.043 0
1520 8 0
1530 C 17 70 2 1 1.E3
1540 -0.052 0
1550 10 0
1580 FINISH

PROGRAM CBEAMC - ANALYSIS OF BEAM-COLUMNS WITH NONLINEAR SUPPORTS
DATE: 06/24/80 TIME: 19:36:42

1.--INPUT DATA

1.--HEADING

EXAMPLE 4 -- MULTIPLE ANCHORED RETAINING WALL
EFFECTS OF AXIAL FORCE ON BENDING EXCLUDED
TENSION-ONLY ANCHORS

2.--BEAM CROSS SECTION DATA

X-COORDINATE		MODULUS OF	SECTION PROPERTIES			
START	STOP	ELASTICITY	AREA	INERT.A	AREA	INERTIA
(IN)	(IN)	(PSI)	(SQIN)	(IN**4)	(SQIN)	(IN**4)
0.00	552.00	2.90E+07	11.20	280.80	11.20	280.80

3.--NODE SPACING DATA

X-COORDINATE		MAXIMUM NODE
START	STOP	SPACING
(FT)	(FT)	(FT)
0.00	50.00	1.00

4.--LOAD DATA
NONE

5.--FIXED SUPPORT DATA
NONE

6.--LINEAR SPRING DATA
NONE

7.--NONLINEAR SPRING DATA

7.A.--NONLINEAR CONCENTRATED SPRINGS

SPRING X-COORD (FT)	ANGLE (DEG)	CURVE COORD. DISPLACEMENT (FT)	MULTIPLIERS FORCE (P)
6.00	90.00	1.00E-03	1.00E+03
DISP. COORDS.	-43.00 0.00		
FORCE COORDS.	8.00 0.00		

SPRING X-COORD (FT)	ANGLE (DEG)	CURVE COORD. DISPLACEMENT (FT)	MULTIPLIERS FORCE (P)
17.00	70.00	1.00E-03	1.00E+03
DISP. COORDS.	-52.00 0.00		
FORCE COORDS.	10.00 0.00		

7.B.--NONLINEAR DISTRIBUTED SPRINGS

DISTRIBUTION	SPRING DIRECTION	SPRING X-COORD (FT)	CURVE COORD. DISPLACEMENT (FT)	MULTIPLIERS FORCE (P)
STARTS	Y	0.00	1.00E-02	1.00E+02
DISP. COORDS.	- .80 12.50			
FORCE COORDS.	-1.33 -12.00			

DISTRIBUTION	SPRING DIRECTION	SPRING X-COORD (FT)	CURVE COORD. DISPLACEMENT (FT)	MULTIPLIERS FORCE (P)
CONTINUES	Y	16.00	1.00E-02	1.00E+02
DISP. COORDS.	- .80 12.50			
FORCE COORDS.	-7.47 -67.20			

DISTRIBUTION	SPRING DIRECTION	SPRING X-COORD (FT)	CURVE COORD. DISPLACEMENT (FT)	MULTIPLIERS FORCE (P)
CONTINUES	Y	17.00	1.00E-02	1.00E+02
DISP. COORDS.	-23.10 23.10			
FORCE COORDS.	-3.03 -43.03			

DISTRIBUTION	SPRING DIRECTION	SPRING X-COORD (FT)	CURVE COORD. DISPLACEMENT (FT)	MULTIPLIERS FORCE (P)
ENDS	Y	46.00	1.00E-02	1.00E+02
DISP. COORDS.	-23.10 23.10			
FORCE COORDS.	-21.15 -61.15			

DISTRIBUTION	SPRING DIRECTION	SPRING X-COORD (FT)	CURVE COORD. DISPLACEMENT (FT)	MULTIPLIERS FORCE (P)
STARTS	Y	26.00	1.00E-02	1.00E+02
DISP. COORDS.	-23.10 23.10			
FORCE COORDS.	20.00 0.00			
DISTRIBUTION	SPRING DIRECTION	SPRING X-COORD (FT)	CURVE COORD. DISPLACEMENT (FT)	MULTIPLIERS FORCE (P)
ENDS	Y	46.00	1.00E-02	1.00E+02
DISP. COORDS.	-23.10 14.50			
FORCE COORDS.	32.50 0.00			
DISTRIBUTION	SPRING DIRECTION	SPRING X-COORD (FT)	CURVE COORD. DISPLACEMENT (FT)	MULTIPLIERS FORCE (P)
STARTS	X	0.00	1.00E-03	1.00E+00
DISP. COORDS.	0.00 100.00			
FORCE COORDS.	0.00 -61.00			
DISTRIBUTION	SPRING DIRECTION	SPRING X-COORD (FT)	CURVE COORD. DISPLACEMENT (FT)	MULTIPLIERS FORCE (P)
CONTINUES	X	16.00	1.00E-03	1.00E+01
DISP. COORDS.	0.00 100.00			
FORCE COORDS.	0.00 -34.20			
DISTRIBUTION	SPRING DIRECTION	SPRING X-COORD (FT)	CURVE COORD. DISPLACEMENT (FT)	MULTIPLIERS FORCE (P)
CONTINUES	X	17.00	1.00E-03	1.00E+01
DISP. COORDS.	-100.00 100.00			
FORCE COORDS.	50.00 -50.00			
DISTRIBUTION	SPRING DIRECTION	SPRING X-COORD (FT)	CURVE COORD. DISPLACEMENT (FT)	MULTIPLIERS FORCE (P)
ENDS	X	46.00	1.00E-03	1.00E+02
DISP. COORDS.	-100.00 100.00			
FORCE COORDS.	10.00 -10.00			
DISTRIBUTION	SPRING DIRECTION	SPRING X-COORD (FT)	CURVE COORD. DISPLACEMENT (FT)	MULTIPLIERS FORCE (P)
STARTS	X	26.00	1.00E-03	1.00E+01
DISP. COORDS.	-100.00 100.00			
FORCE COORDS.	50.00 -50.00			
DISTRIBUTION	SPRING DIRECTION	SPRING X-COORD (FT)	CURVE COORD. DISPLACEMENT (FT)	MULTIPLIERS FORCE (P)
ENDS	X	46.00	1.00E-03	1.00E+02
DISP. COORDS.	-100.00 100.00			
FORCE COORDS.	10.00 -10.00			

PROGRAM CBEAMC - ANALYSIS OF BEAM-COLUMNS WITH NONLINEAR SUPPORTS
 DATE: 06/24/80 TIME: 19:37:21

II.--SUMMARY OF RESULTS

II.A.--HEADING
 EXAMPLE 4 -- MULTIPLE ANCHORED RETAINING WALL
 EFFECTS OF AXIAL FORCE ON BENDING EXCLUDED
 TENSION-ONLY ANCHORS

II.B.--MAXIMA

	MAXIMUM POSITIVE	X-COORD (FT)	MAXIMUM NEGATIVE	X-COORD (FT)
AXIAL DISPLACEMENT (FT) :	8.584E-03	17.00	0.	0.00
LATERAL DISPLACEMENT (FT):	1.775E-02	0.00	-1.725E-01	32.00
ROTATION (RAD) :	5.487E-05	46.00	-7.437E-04	7.00
AXIAL FORCE (P) :	3.128E+02	17.00	-3.107E+03	17.00
SHEAR (P) :	7.412E+03	17.00	-4.155E+03	26.00
BENDING MOMENT (P-FT) :	3.618E+04	23.00	-5.638E+03	6.00

II.C.--FORCES IN CONCENTRATED NONLINEAR SPRINGS

X-COORD (FT)	ANGLE (DEG)	DEFORMATION (FT)	FORCE (P)
6.00	90.00	-3.452E-02	6.423E+03
17.00	70.00	-1.145E-01	1.000E+04

III.--COMPLETE RESULTS

III.A.--HEADING
 EXAMPLE 4 -- MULTIPLE ANCHORED RETAINING WALL
 EFFECTS OF AXIAL FORCE ON BENDING EXCLUDED
 TENSION-ONLY ANCHORS

III.B.--DISPLACEMENTS AND INTERNAL FORCES

X-COORD (FT)	DISPLACEMENTS			INTERNAL FORCES		
	AXIAL (FT)	LATERAL (FT)	ROTATION (RAD)	AXIAL (P)	SHEAR (P)	MOMENT (F-FT)
0.00	8.578E-03	1.775E-02	-8.660E-03	0.	0.	0.
1.00	8.578E-03	9.087E-03	-8.661E-03	5.986E+00	-3.470E+02	-1.728E+02
2.00	8.578E-03	4.236E-04	-8.668E-03	1.348E+01	-6.824E+02	-6.902E+02
3.00	8.578E-03	-8.253E-03	-8.687E-03	2.248E+01	-9.463E+02	-1.510E+03
4.00	8.578E-03	-1.696E-02	-8.723E-03	3.298E+01	-1.214E+03	-2.587E+03
5.00	8.578E-03	-2.571E-02	-8.780E-03	4.499E+01	-1.519E+03	-3.950E+03
6.00	8.578E-03	-3.452E-02	-8.864E-03	5.851E+01	-1.863E+03	-5.638E+03
6.00	8.578E-03	-3.452E-02	-8.864E-03	5.851E+01	4.560E+03	-5.638E+03
7.00	8.579E-03	-4.343E-02	-8.925E-03	7.354E+01	4.177E+03	-1.266E+03
8.00	8.579E-03	-5.235E-02	-8.912E-03	9.007E+01	3.757E+03	2.704E+03
9.00	8.579E-03	-6.123E-02	-8.832E-03	1.081E+02	3.297E+03	6.234E+03
10.00	8.579E-03	-6.999E-02	-8.694E-03	1.277E+02	2.800E+03	9.286E+03
11.00	8.580E-03	-7.860E-02	-8.506E-03	1.487E+02	2.264E+03	1.182E+04
12.00	8.580E-03	-8.699E-02	-8.279E-03	1.713E+02	1.690E+03	1.380E+04
13.00	8.581E-03	-9.515E-02	-8.022E-03	1.953E+02	1.077E+03	1.519E+04
14.00	8.582E-03	-1.030E-01	-7.746E-03	2.209E+02	4.259E+02	1.594E+04
15.00	8.582E-03	-1.106E-01	-7.462E-03	2.480E+02	-2.635E+02	1.603E+04
16.00	8.583E-03	-1.180E-01	-7.183E-03	2.766E+02	-9.913E+02	1.540E+04
17.00	8.584E-03	-1.250E-01	-6.922E-03	3.128E+02	-1.985E+03	1.395E+04
17.00	8.584E-03	-1.250E-01	-6.922E-03	-3.107E+03	7.412E+03	1.395E+04
18.00	8.575E-03	-1.318E-01	-6.613E-03	-3.064E+03	6.189E+03	2.075E+04
19.00	8.565E-03	-1.382E-01	-6.195E-03	-3.019E+03	4.962E+03	2.633E+04
20.00	8.556E-03	-1.441E-01	-5.689E-03	-2.972E+03	3.725E+03	3.067E+04
21.00	8.547E-03	-1.496E-01	-5.110E-03	-2.924E+03	2.475E+03	3.378E+04
22.00	8.538E-03	-1.544E-01	-4.502E-03	-2.875E+03	1.207E+03	3.562E+04
23.00	8.529E-03	-1.586E-01	-3.865E-03	-2.824E+03	-8.444E+01	3.618E+04
24.00	8.521E-03	-1.621E-01	-3.230E-03	-2.772E+03	-1.405E+03	3.544E+04
25.00	8.512E-03	-1.650E-01	-2.620E-03	-2.718E+03	-2.760E+03	3.336E+04
26.00	8.504E-03	-1.674E-01	-2.058E-03	-2.663E+03	-4.155E+03	2.991E+04
27.00	8.496E-03	-1.692E-01	-1.565E-03	-2.563E+03	-3.841E+03	2.591E+04
28.00	8.488E-03	-1.705E-01	-1.140E-03	-2.460E+03	-3.520E+03	2.223E+04
29.00	8.481E-03	-1.715E-01	-7.773E-04	-2.353E+03	-3.197E+03	1.887E+04
30.00	8.474E-03	-1.721E-01	-4.710E-04	-2.243E+03	-2.876E+03	1.583E+04
31.00	8.467E-03	-1.724E-01	-2.155E-04	-2.129E+03	-2.561E+03	1.311E+04
32.00	8.460E-03	-1.725E-01	-5.342E-06	-2.011E+03	-2.255E+03	1.071E+04
33.00	8.454E-03	-1.724E-01	1.649E-04	-1.890E+03	-1.962E+03	8.599E+03
34.00	8.449E-03	-1.722E-01	3.005E-04	-1.766E+03	-1.684E+03	6.777E+03
35.00	8.444E-03	-1.719E-01	4.062E-04	-1.638E+03	-1.423E+03	5.225E+03
36.00	8.439E-03	-1.714E-01	4.867E-04	-1.507E+03	-1.181E+03	3.924E+03
37.00	8.434E-03	-1.709E-01	5.464E-04	-1.372E+03	-9.593E+02	2.855E+03
38.00	8.430E-03	-1.703E-01	5.890E-04	-1.233E+03	-7.587E+02	1.998E+03
39.00	8.427E-03	-1.697E-01	6.182E-04	-1.091E+03	-5.803E+02	1.331E+03
40.00	8.424E-03	-1.691E-01	6.370E-04	-9.461E+02	-4.248E+02	8.301E+02
41.00	8.421E-03	-1.684E-01	6.484E-04	-7.972E+02	-2.928E+02	4.733E+02
42.00	8.419E-03	-1.678E-01	6.545E-04	-6.448E+02	-1.849E+02	2.364E+02
43.00	8.417E-03	-1.671E-01	6.573E-04	-4.889E+02	-1.013E+02	9.538E+01
44.00	8.416E-03	-1.665E-01	6.583E-04	-3.295E+02	-4.244E+01	2.557E+01
45.00	8.415E-03	-1.658E-01	6.585E-04	-1.665E+02	-8.572E+00	2.166E+00
46.00	8.415E-03	-1.652E-01	6.585E-04	0.	0.	0.

III.C.--FORCES IN DISTRIBUTED NONLINEAR SPRINGS
 DISTRIBUTED SPRING FORCES

X-COORD (FT)	AXIAL (P/FT)	LATERAL (P/FT)
0.00	-5.233E+00	-3.396E+02
1.00	-6.739E+00	-3.479E+02
2.00	-8.246E+00	-3.162E+02
3.00	-9.752E+00	-2.481E+02
4.00	-1.126E+01	-2.865E+02
5.00	-1.277E+01	-3.249E+02
6.00	-1.427E+01	-3.633E+02
7.00	-1.578E+01	-4.016E+02
8.00	-1.729E+01	-4.400E+02
9.00	-1.879E+01	-4.784E+02
10.00	-2.030E+01	-5.168E+02
11.00	-2.181E+01	-5.551E+02
12.00	-2.332E+01	-5.935E+02
13.00	-2.483E+01	-6.319E+02
14.00	-2.633E+01	-6.703E+02
15.00	-2.784E+01	-7.086E+02
16.00	-2.935E+01	-7.470E+02
17.00	-4.292E+01	-1.221E+03
18.00	-4.435E+01	-1.224E+03
19.00	-4.578E+01	-1.231E+03
20.00	-4.721E+01	-1.242E+03
21.00	-4.863E+01	-1.258E+03
22.00	-5.005E+01	-1.279E+03
23.00	-5.147E+01	-1.305E+03
24.00	-5.289E+01	-1.337E+03
25.00	-5.430E+01	-1.374E+03
26.00	-5.571E+01	-1.416E+03
26.00	-9.823E+01	3.081E+02
27.00	-1.017E+02	3.182E+02
28.00	-1.052E+02	3.230E+02
29.00	-1.087E+02	3.229E+02
30.00	-1.122E+02	3.187E+02
31.00	-1.157E+02	3.108E+02
32.00	-1.192E+02	2.997E+02
33.00	-1.227E+02	2.859E+02
34.00	-1.261E+02	2.698E+02
35.00	-1.296E+02	2.518E+02
36.00	-1.331E+02	2.323E+02
37.00	-1.366E+02	2.115E+02
38.00	-1.401E+02	1.897E+02
39.00	-1.436E+02	1.671E+02
40.00	-1.471E+02	1.438E+02
41.00	-1.506E+02	1.200E+02
42.00	-1.541E+02	9.582E+01
43.00	-1.577E+02	7.128E+01
44.00	-1.612E+02	4.642E+01
45.00	-1.647E+02	2.127E+01
46.00	-1.683E+02	-4.171E+00

In accordance with letter from DAEN-RDC, DAEN-ASI dated 22 July 1977, Subject: Facsimile Catalog Cards for Laboratory Technical Publications, a facsimile catalog card in Library of Congress MARC format is reproduced below.

Dawkins, William P.

User's guide: Computer program for analysis of beam-column structures with nonlinear supports (CBEAMC) / by William P. Dawkins. -- Vicksburg, Miss. : U.S. Army Engineer Waterways Experiment Station ; Springfield, Va. : available from NTIS, 1982.

90 p. in various pagings ; ill. ; 27 cm. -- (Instruction report ; K-82-6)

Cover title.

"June 1982."

Final report.

"Prepared for Office, Chief of Engineers, U.S. Army."

"Monitored by Automatic Data Processing Center, U.S. Army Engineer Waterways Experiment Station."

"A report under the Computer-Aided Structural Engineering (CASE) Project."

Bibliography: p. 36.

1. CBEAMC (Computer program). 2. Computer programs.
3. Mathematical models. 4. Structural frames--Models.

Dawkins, William P.

User's guide: Computer program for analysis : ... 1982.
(Card 2)

5. Structures, Theory of. I. United States. Army. Corps of Engineers. Office of the Chief of Engineers. II. U.S. Army Engineer Waterways Experiment Station. Automatic Data Processing Center. III. Title IV. Series: Instruction report (U.S. Army Engineer Waterways Experiment Station) ; K-82-6.
TA7.W34i no.K-82-6

END

DATE

FILMED

B-82

DTIC