

MICROCOPY RESOLUTION TEST CHART

NATIONAL BUREAU OF STANDARDS-1963-A

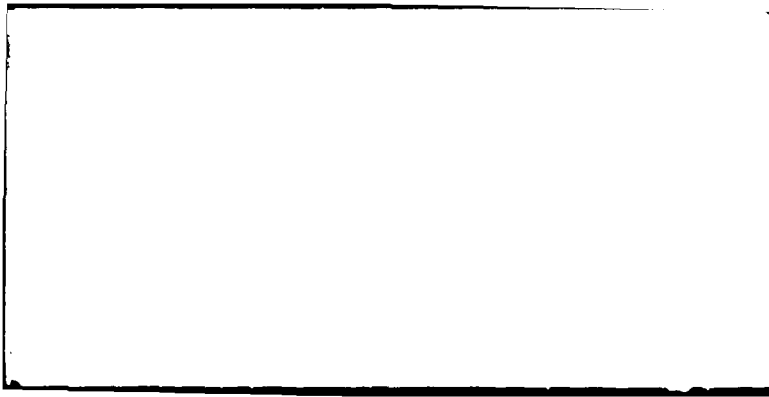

## **DISCLAIMER NOTICE**

**THIS DOCUMENT IS BEST QUALITY PRACTICABLE. THE COPY FURNISHED TO DTIC CONTAINED A SIGNIFICANT NUMBER OF PAGES WHICH DO NOT REPRODUCE LEGIBLY.**



# Det norske Veritas

## Ship Division, Maritime Advisory Services

(2)

POSTAL ADDRESS: P.O. BOX 300, 1322 HØVIK, NORWAY

TELEPHONE: +47(02) 12 99 00

CABLE ADDRESS: VERITAS, OSLO

TELEX: 16 192 VERIT N

### TECHNICAL REPORT

Date 24-08-77	
VERITAS Report No. 77-345	Subject Group
Title of Report DAMAGE TO SHIPS DUE TO COLLISION AND GROUNDING.	
Client/Sponsor of project	Department 014
Work carried out by Henry Vaughan (The University of British Columbia)	Project No. Approved by <i>Hans Richard Hansen</i> Hans Richard Hansen Principal Surveyor Client/Sponsor ref.
	Reporters sign. For H. Vaughan <i>Kåre Rygg-Johansen</i>

Summary

A method is presented which enables the damage to a ship involved in a collision or grounding to be estimated in terms of the lost kinetic energy. The formulae derived are based upon dimensional analysis and involve two unknown coefficients. One of the unknowns is identified with the well-known Minorsky volume coefficient. The other unknown relates the absorbed energy to the area of the torn plate and is determined from a series of small scale tests conducted in Japan.

This document has been approved for public release and sale; its distribution is unlimited.

SELECTED  
JUL 28 1982  
A

4 Indexing terms

Collision and Grounding  
Semianalytical method

Distribution statement:

- No distribution without permission from the responsible department.
- Limited distribution within Det norske Veritas.
- Free distribution.

Date of last rev.      Rev. No.

Number of pages  
76/13

Det norske Veritas has no liability for loss or damage caused by its organs, officers, employees or others who act under assignment from the Institution, regardless of whether such persons have acted intentionally or negligently and irrespective of whether the loss or damage has affected a shipping company, a shipyard or others who have requested the Institution's assistance or any third party who voluntarily or contractually enters into an agreement with the Institution, has acted or made arrangements in reliance on assistance given or information given by or on behalf of the Institution. This, in cases of contract and otherwise, shall not be construed as a limitation of the Institution's liability for loss or damage, insofar as such limitation is not permitted by law.

44-345

CONTENTS

- 1. Introduction
- 2. Proposed formulae relating damage to absorbed energy
  - 2.1. Penetration of side structure by wedge shaped bow.
  - 2.2. Crushing of bow impacting against side structure.
- 3. Experimental Verification of Proposed Formulae
  - 3.1. Determination of True Penetration.
  - 3.2. Volumes of damaged material and areas of torn plate.
  - 3.3. Relation between damage and absorbed energy for side structure.
  - 3.4. Work done in crushing bow structure.
- 4. Discussion of formulae and comparison with other methods
  - 4.1. Comparison with Minorsky for penetration by rigid bow.
  - 4.2. Comparison with NCRE for LNG collision barrier.
  - 4.3. Grounding with significant plate tearing.
- 5. Example: Grounding of LNG carrier.
- 6. Conclusion.

References

Acknowledgements



Accession For	
DDIS GRA&I	<input checked="" type="checkbox"/>
DDIC TAB	<input type="checkbox"/>
Unannounced	<input type="checkbox"/>
Justification	
<i>Copy to file</i>	
By	
Distribution/	
Availability Codes	
Dist	Avail and/or Special
A	23

## NOTATION

$\alpha$	semi-angle of bow structure
$\theta$	semi-angle of tip of ice floe or sharp rock
$A_s$	area of torn plate in side structure (m.mm)
$p_s$	penetration of side structure (m)
$p_b$	penetration of bow (m)
$p$	Minorsky type penetration = $p_s + p_b$
$t_s$	total thickness of penetrated deck plate (mm)
$\bar{t}_s$	deck thickness with stiffeners (mm)
$V_s$	volume of damaged material in side structure (m <sup>2</sup> mm)
$W_s$	energy absorbed by side structure (ton-metre)
$W_b$	energy absorbed by bow structure (ton-metre)
$L$	width of penetration of side structure (m)
$l$	length of torn plate in ships bottom (m)
$S$	energy function per unit area of torn plate
$E$	energy function per unit volume of damaged material
$R_T$	resistance factor based on penetration $p$ (m <sup>2</sup> mm)
$R_T^*$	resistance factor based on penetration $p_s$ (m <sup>2</sup> mm)
$\sigma$	maximum load carried by bow (tons)
$G_s$	equivalent to $W_s$ measured in ton-knots <sup>2</sup>
$V$	displacement of ship (tons)
$v$	velocity of ship causing penetration to inner tank
$\pi_1 - \pi_4$	dimensionless variables

List of Figures

- Fig. 1. Torn bottom-plating of ship due to grounding.
- Fig. 2. Penetration of plate by wedge.
- Fig. 3.  $W_s - 4.75 R_T^*$  versus  $A_s$ .
- Fig. 4.  $W_b$  versus  $\sigma p_b$
- Fig. 5. Comparison of methods for penetration of side structure by rigid bow.
- Fig. 6. General arrangement of LNG tanker.
- Fig. 7. Transverse sections of bow, profile of leading LNG tank, and profile of penetrating object.
- Fig. 8. Plate thicknesses of bow structure.
- Fig. 9. Material damaged in grounding:
- a) bottom plating,
  - b) inner bottom,
  - c) vertical girder.
- Fig. 10. Collision of ship with rock occurring during manoeuvring or drifting.

## Damage to Ships due to Collision and Grounding

by Henry Vaughan, Ph.D., MRINA

Summary. A method is presented which enables the damage to a ship involved in a collision or grounding to be estimated in terms of the lost kinetic energy. The formulae derived are based upon dimensional analysis and involve two unknown coefficients. One of the unknowns is identified with the well-known Minorsky volume coefficient. The other unknown relates the absorbed energy to the area of the torn plate and is determined from a series of small scale tests conducted in Japan.

The method agrees with Minorsky for conventional ship-ship collisions in which the bow of the striking ship is fairly stiff. It also agrees with other published work for problems involving safety calculations for critical penetration of LNG/LPG side structures.

The new feature of the proposed method is that it is also appropriate for grounding problems in which there may be significant tearing of the ships bottom. Minorsky's method is not appropriate for such problems and no other analytic method has previously been proposed.

An example is included in which a LNG tanker runs over a sharp projection such as an ice-floe tip. A critical situation is found to exist in which the ice-tip by-passes the bulbous bow and penetrates the hull close to the leading LNG tank. Because of the relatively small amount of protective material in the ship bottom, safe operating speeds are correspondingly low.

## I. INTRODUCTION

Only two methods have previously been published for calculating the work done in crushing a ship structure, the first by Minorsky<sup>(1)</sup> and the other by the structures group at NCRE<sup>(2)</sup>. Both of these investigations were prompted by the same requirement: to estimate the energy absorbing characteristics of ship side structures in order to design safely against penetration of an inner container in the event of collision. Minorsky's method is the most commonly used and is a semi-empirical method based upon the records kept by the U.S. Coast Guard of many ship collisions.

Minorsky found that he could relate the kinetic energy lost in a collision to the volume of damaged material. The NCRE method uses a simple energy calculation based upon the crippling stress of a plate when loaded by a rigid wedge. Minorsky's method has become the standard way of calculating the resistance of ship structures against collision damage, particularly for obtaining safety estimates for LNG/LPG carriers where penetration of a container may have very serious consequences.

Although a lot of work has been done experimentally to verify Minorsky's equation for collisions between deformable bows and side structures, see for example Woisin<sup>(3)</sup>, Akita and Kitamura<sup>(4)</sup>, and many applications have been made to problems involving safety calculations, see for example Haywood<sup>(5)</sup>, very little, if any literature exists on predicting damage due to grounding. This paper, although presenting new material which is suitable for conventional ship-ship collisions, is directed primarily towards the

problem of damage due to grounding and the associated safety calculations.

A grounding from some aspects may be treated as a collision problem. There are however some very important differences that distinguish it from a conventional ship collision. Firstly the damage is below the water line and penetration, if it occurs, will be in the bottom structure rather than in the wall or side collision barrier. Secondly, an investigation by Card<sup>(6)</sup> in 1975 showed that most bottom damage is due to shallow penetration resulting in tearing of the bottom plate rather than deep penetration accompanied by significant structural damage. Based merely upon the reported depths of bottom damage to 30 tankers he concluded that if a B/15 double bottom had been fitted, 90% of the oil-tank spills would not have occurred. He also mentioned that an original analytic study in bottom damage had been abandoned because of the complexity of the problem.

When Minorsky published his article almost twenty years ago he made use of records obtained from the U.S. Coast Guard based on reported collisions which in some cases had occurred many years earlier. Consequently the design curve he deduced was based mainly on ships which were built probably between 1940 and 1955. A number of changes in ship design have emerged since then which need to be kept in mind when applying Minorsky's formula. Firstly the size of ships has increased ten times in terms of displacement, with a corresponding increase in kinetic energy associated with a ship at its operating speed. The energy levels at which

Minorsky's curve is most reliable are within the range 500-2000 tons-knots<sup>2</sup> x 10<sup>3</sup>. In 1958 this range included a large ship at operating speed, say 20,000 tons at 15 knots, losing most of its kinetic energy during a collision. However, Minorsky advises caution in extrapolating to energy levels corresponding to the Queen Mary at full speed. A modern LNG carrier at operating speed does have kinetic energy far in excess of the range considered by Minorsky, but this does not mean that his method cannot be used for critical penetration-speed calculations. Typically a large tanker with protective barrier can withstand a 5 knot impact from a 50,000 ton colliding ship, which involves an initial kinetic energy of 625 (tons-knots<sup>2</sup> x 10<sup>3</sup>), conveniently in the range considered by Minorsky. Similarly a 100,000 ton LNG carrier at 4 knots, being brought to rest by colliding with a submerged rock suffers a kinetic energy loss of 800 (tons-knots<sup>2</sup> x 10<sup>3</sup>), again well within the range considered by Minorsky. The extent of the damage to the ship in absorbing this energy is of paramount importance and developing a method for its prediction is the main purpose of this paper.

Another change in design since the appearance of Minorsky's work has been the softening of bow structures. The original concept in safety was based on the principle of self preservation, thus the bow of a ship was designed fairly rigidly so that if a second ship was struck, the struck ship suffered the most damage. Now it is realised that in the interest of all, notably the

environmentalists, it is better to let the bow of the striking ship crumple, thereby absorbing energy so that the struck ship, with significant side protection now included, will not be so severely penetrated.

In 1958, when Minorsky's paper appeared, bow structures were still relatively stiff. Consequently it is probable that in the collisions investigated by him, most of the damage occurred in the struck ship. This is certainly so in the one case which he cites in Table 3 of his paper as being typical. The damage to the struck ship is about ten times that of the striking ship. Minorsky's results then are very appropriate for collisions involving a rigid bow and a deformable side structure.

A parallel situation occurs when a ship strikes a submerged rock. The rock may be considered rigid and it may be assumed that the energy is absorbed almost entirely by the ship structure. Minorsky's method may then be used to relate the amount of the damaged structure to the absorbed energy. There is however, one important qualification. The grounding must be such that the damage is mainly volumetric rather than due to plate tearing.

As pointed out by Card, most groundings are not of the above type but result in significant tearing. The type of damage envisaged is shown in Figure 1. Most of the kinetic energy of the grounding ship is absorbed by tearing the plate rather than by bending, twisting and crumpling of the inner structure. Minorsky's method, based exclusively on volume damage, is not appropriate for this type of problem and a new approach is essential.

The paper starts by making a dimensional analysis of the penetration problem. Using the pi theorem the problem is reduced to a functional form involving four dimensionless variables. A specific functional form is then assumed which expresses the work done in deforming the structure as a linear combination of the volume of damaged material and the area of torn plate. Two unknown coefficients are introduced at this stage. A detailed interpretation of some experiments made by Akita and Kitamura<sup>(4)</sup> in Japan verify that the assumed functional form is correct and enables values to be assigned to the two coefficients.

The formula obtained is shown to reduce to Minorsky's formula for conventional problems involving penetration of a side structure by a rigid bow. It also predicts values in agreement with those obtained by Haywood<sup>(5)</sup> for collision between a deformable bow and a LNG side structure. For the particular case in which there is significant tearing but little volume destruction there is no other work available with which to make a comparison. The agreement with Minorsky, Akita and Kitamura, and Haywood for three very different situations, together with the fact that the theory is formulated correctly from dimensional considerations, suggests very strongly that the proposed formula is correct.

The paper concludes by considering a detailed calculation involving a LNG tanker running over a sharp object. The damage to the bottom is both of the distortion and tearing type. Of note is the fact that in the most critical situation, the bow

structure does not protect the LNG tank significantly so that the initial penetration can occur dangerously close to the tank with very little resulting resistance to further critical damage.

## 2. Formulae relating damage to absorbed energy

### 2.1. Penetration of side structure by wedge-shaped bow

Consider a side deck-structure being penetrated by a rigid wedge of semi-angle  $\alpha$  as shown in Figure 2. In calculating the work done to penetrate the grillage to a significant depth ( $p_s \gg t$ ) it is assumed that a certain amount of work is required to tear or fracture the plate and an independent amount is required to push aside the material to permit the entry of the wedge. In classical fracture or crack propagation studies a surface energy function is assumed to exist which is the basis of the crack propagation criterion. Whereas we are not concerned with classical crack propagation, a surface energy function  $S$  per unit area is assumed which is a measure of the work done in tearing or penetrating the structure with a wedge of zero angle  $\alpha$ . In addition, prompted by Minorsky's work an energy function  $E$  per unit volume is assumed which is a measure of the work done in pushing aside the material.

The work done  $W_s$  to penetrate the side structure by the wedge can therefore be expected to depend on

$S$ , energy function per unit area of penetration

$E$ , energy function per unit volume of displaced material,  
 $p_s$ , depth of penetration into side structure  
 $\alpha$ , the semi-angle of the wedge  
 $t_s$ , the total plate thickness of the side decks.

Functionally it is possible to express this relationship as

$$F(W_s, S, E, p_s, \alpha, t_s) = 0 \quad (2.1)$$

There are two fundamental dimensions in the relationship (2.1), namely force and distance. The pi theorem of dimensional analysis then tells us that the original function involving six independent variables can be rewritten in terms of four dimensionless variables  $\pi_1$ - $\pi_4$ .

For appropriate dimensionless variables are easily deduced to be

$$\pi_1 = W/Sp^2, \pi_2 = W/Ep^3, \pi_3 = p/t, \pi_4 = g(\alpha) \quad (2.2)$$

where  $g(\alpha)$  is any function of  $\alpha$ .

The pi theorem merely tells us that (2.1) can be rewritten as

$$f(\pi_1, \pi_2, \pi_3, \pi_4) = 0 \quad (2.3)$$

with no indication given as to the form of  $f$ .

Based on Minorsky's work and assuming that the energy due to tearing can be separated from the energy of distortion,

it is assumed that (2.3) can be written as

$$\frac{a}{\pi_1} + \frac{b\pi_4}{\pi_2} - \frac{1}{\pi_3} = 0 \quad (2.4)$$

where a and b are constants.

In terms of the original physical variables (2.4) becomes

$$aSp_s t_s + bEp_s^2 t_s g(\alpha) - W_s = 0$$

Choosing  $g(\alpha) = \tan \alpha$  this equation finally becomes

$$W_s = aSA_s + bEV_s \quad (2.5)$$

where  $A_s = p_s t_s$  is the total area of fracture or tearing,

$$V_s = Lp_s t_s / 2 = p_s^2 t_s \tan \alpha$$

is the volume of material displaced, a and b are coefficients to be determined by experiment or other means.

If we limit our attention to steel ships then we may take S and E as constants in our investigation so that (2.5) becomes

$$W_s = \bar{a}A_s + \bar{b}V_s \quad (2.6)$$

In this case  $\bar{a}$  and  $\bar{b}$  can be deduced from experiments on steel structures only, and the results applied to any other similar structures made of the same material.

Notice that  $A_s$  and  $V_s$  are obtained from considering the actual or true penetration  $p_s$ , not the total penetration as defined by Minorsky.

## 2.2. Crushing of bow impacting against side-structure.

As in section 2.1 minor collisions are excluded and we confine attention to those cases in which the damage to the bow is significant. The main mechanism for destruction is assumed to be crumpling of the bow. Although a certain amount of tearing may occur, most of the energy absorbed in the collision goes into pushing the leading material back into the ship and damage is therefore of the volume-displacement type rather than the surface tearing type.

Based upon some experimental results discussed later the energy  $W_b$  absorbed by the bow is taken as

$$W_b = c\sigma p_b \quad (2.7)$$

where  $p_b$  is the true damaged length of the bow, (distinguished from the Minorsky penetration  $p$ ),  $\sigma$  is a characteristic maximum load associated with the bow structure, and  $c$  is a constant to be determined.

## 3. Experimental Verification of Proposed Formulae

Two excellent papers on model tests for assessment of damage in ship collisions have been published by Woisin<sup>(3)</sup> in

Germany and Akita and Kitamura<sup>(4)</sup> in Japan. Only the Japanese workers have included all the information required to investigate the validity of the postulates (2.6) and (2.7) and attention is therefore confined to their paper. In order to avoid confusion the same units are used in this section as in (4).

### 3.1. Determination of True Penetration

Akita and Kitamura consider six bow (stem) structures of varying strength penetrating a transversely framed side-structure. Three penetrations are considered equal to 100 mm, 200 mm and 300 mm on a stem and side of depths 600 mm and 350 mm respectively. Penetration is defined according to Minorsky and is the sum of the individual penetrations of the bow and the side. Thus,

$$p = p_s + p_b \quad (3.1)$$

We first of all obtain the individual penetrations  $p_s$  and  $p_b$  by direct measurement from Figures 3-8 of the paper (4). The values so obtained, using Akita's notation for the six bow structures are given in Table 1. Perhaps a remark on the fractional form of the penetrations is in order. The penetrations were obtained by direct scaling from the Figures given in (4). Thus, using a 1:20 scale and considering Fig. 7, the bow deformation of L3 at 300 mm total penetration  $p$  is 2 increments and the side deformation is 20 increments. Since

Table 1. Penetration of side structure and bow

	p = 0.1m		p = 0.2m		p = 0.3m	
	$10p_s$ m	$10p_b$ m	$10p_s$ m	$10p_b$ m	$10p_s$ m	$10p_b$ m
T1	0.00	1.00	0.00	2.00	0.00	3.00
L1	3/8	5/8	10/17	24/17	9/14	33/14
T2	4/9	5/9	2/3	4/3	9/11	24/11
L2	8/11	3/11	16/11	6/11	2	1
L3	7/8	1/8	34/19	4/19	30/11	3/11
L4	8/9	1/9	11/6	1/6	31/11	2/11

p = total penetration in m.

$p_s$  = penetration into side structure.

$p_b$  = penetration into bow.

$p = p_s + p_b$ .

the total penetration is 300 mm the individual penetrations must be  $.3 \times 2/(2 + 20)m$  and  $.3 \times 20/(2 + 20)m$  as shown in row 5 of Table 1.

### 3.2. Volume of damaged material and areas of torn plate

Let  $V$  be the volume of material damaged in the side structure for a penetration of 300 mm.

Column 4 of Table 3 in (4) gives

$$1.33 R_T \times 175.8 \times 0.027 = 6.43 \text{ m}^2 \cdot \text{mm}$$

where  $R_T = 2V$  for a wedge.

Hence  $R_T = 2V = 1.02 \text{ m}^2 \cdot \text{mm}$  for 300 mm penetration  $p$ .

The volume for a true penetration  $p_s$ , based on the undeformed shape of the penetrating bow is given by

$$R_T^* = 2V_s = 1.02 \times (p_s/0.3)^2 \quad (3.2)$$

Note  $R_T^*$  is based on the true penetration  $p_s$  and is different to Minorsky's definition.

Using the values for  $p_s$  given above in Table 1 the corresponding true volumes of damaged material in the side structure are found from (3.2) and are given in Table 2.

Based on the undeformed shape of the penetrating bow (see Figure 2) the following formulae hold

$$A_s = t_s \times p_s \quad (i)$$

$$V_s = \bar{t}_s \times p_s \times p_s \tan \alpha \approx A_s p_s \tan \alpha \quad (ii) \quad (3.3)$$

$$A_s \approx V_s t_s / \bar{t}_s \tan \alpha \quad (iii)$$

Table 2. Volume of damaged material and area of torn plate in side structure

	p = 0.1m		p = 0.2m		p = 0.3m	
	$2V_S = R_T^*$	$A_S$	$2V_S = R_T^*$	$A_S$	$2V_S = R_T^*$	$A_S$
T1	0.00	0.00	0.00	0.00	0.00	0.00
L1	.0159	0.360	.0392	0.565	.0468	0.617
T2	0.0224	0.427	.0504	0.640	.0759	0.785
L2	.0599	0.698	.240	1.40	.453	1.92
L3	.0868	0.840	.363	1.72	.843	2.62
L4	.0895	0.853	.381	1.76	.900	2.71

$V_S$  volume of damaged material in  $m^2 \cdot mm$ .

$A_S$  area of torn plating in  $m \cdot mm$ .

The area of torn plate could be found from the values of  $V_S$  and  $p_S$  given in Tables 1 and 2 by using (3.3 ii) with  $\alpha = 30^\circ$ . However, when calculating the volumes  $V_S$  (or equivalently  $R_T^*$ ) the effect of stiffeners is included by increasing the thickness of the plating from  $t$  to  $\bar{t}$  in the usual way. Calculating  $A_S$  from (3.3 ii) would then give a rather higher value than that obtained from (3.3 i). It may be expected that the plating tears between stiffeners so that the true plate thickness should be used in calculating  $A_S$ .

In the structure considered by Akita, there are 3 decks each of thickness 3.2 mm. For a penetration  $p_S$  m the area of torn material is therefore

$$A_S = p_S \times 3 \times 3.2 \text{ m.mm} \quad (3.4)$$

The values of  $A_S$  for corresponding  $p_S$  are given in Table 2.

### 3.3. Relation between damage and absorbed energy for side structure

The work done in penetrating the side structure by the amount  $p_S$  is given by Akita in Table 3 of his paper, reproduced in Table 3 here. The immediate aim is to show that the experimental results of Akita verify that a formula of the type (2.6) is correct and then to deduce values of  $\bar{a}$  and  $\bar{b}$ .

Firstly, it is beneficial to examine the magnitudes of the quantities involved in Akita's experiments and compare them

Table 3. Comparison of Theory and Experiment

	Theory		Experiment	Minorsky
	$4.75 R_T^*$	$4.75 R_T^* + 3.4 A_S$	Absorbed Energy $W_S$	$4.75 R_T$
T1	0.0	0.0	0.0	0.7
L1	0.075	1.3	0.9	"
T2	0.106	1.5	1.4	"
L2	0.285	2.7	3.1	"
L3	0.412	3.3	3.5	"
L4	0.425	3.3	4.3	"
T1	0.0	0.0	0.0	2.9
L1	0.186	2.1	2.3	"
T2	0.239	2.4	2.4	"
L2	1.14	5.9	6.2	"
L3	1.72	7.5	7.4	"
L4	1.81	7.8	8.1	"
T1	0.0	0.0	0.0	6.4
L1	0.222	2.3	2.6	"
T2	0.361	3.0	3.3	"
L2	2.15	8.7	8.7	"
L3	4.00	12.9	11.4	"
L4	4.28	13.5	13.2	"

with the full scale information gathered by Minorsky. Minorsky considered volumes of damaged material  $R_T$  over the range 0 to 4000 ft<sup>2</sup>.in., that is, 0 to 10,000 m<sup>2</sup>-mm. In the upper range (say from 2000-4000 ft<sup>2</sup>-in.) there is very good evidence to show that the work done depends linearly on the volume of material displaced. In the units preferred here, Minorsky's relationship is

$$W = 4.75 R_T + \text{const.} \quad \text{ton.metre.}$$

If the example in Fig. 2 of Minorsky is typical, as he states, then his result is based on collisions in which most of the damage occurs in the struck ship (in his typical example the ratio of side damage to bow damage is ten to one). In such an event, the value of  $R_T$  as defined by Minorsky and based on total penetration  $p$ , is close to the value  $R_T^*$  defined here which is based on true penetration  $p_s$ . Consequently coefficient  $\bar{b}$  of equation (2.6) is identified with Minorsky's value. Recalling that for a penetrating wedge-shaped bow  $2V_s = R_T^*$ , it follows that

$$\bar{b}/2 = 4.75 \text{ ton/m.mm} \quad (3.5)$$

Minorsky indicates that the results over the lower quarter range of his data are scattered. Information for small values of  $V_s$  is provided by Akita which may be used to deduce the value of  $\bar{a}$  in (2.6). This value is based on a theory which is dimensionally correct and which will therefore hold for all ranges of  $V_s$ .

Rewriting (2.6) and using (3.5) gives

$$W_S - 4.75 R_T^* = \bar{a} A_S \quad \text{ton.m.} \quad (3.6)$$

Values of  $W_S$  and  $R_T^*$  are given in Table 3 and corresponding values of  $A_S$  are given in Table 2. A graph of  $W_S - 4.75 R_T^*$  versus  $A_S$  is shown in Figure 3. The graph shows convincingly that a linear relationship of the form (3.5) exists and, in the units used, the value of  $\bar{a}$  is 3.4 ton/mm.

Table 3 compares the calculated values of  $4.75 R_T^* + 3.4 A_S$  with the experimental values of  $W_S$  obtained from the eighteen tests. Agreement is good in all cases. The values given by Minorsky's theory, as interpreted by Akita are also given in Table 3. Clearly there is no link between these values and the measured values.

There is a fundamental difference between the formula proposed here given by (3.6) and that derived by Minorsky which is worth commenting on. Minorsky's formula contains a constant value (independent of  $R_T$  and  $A_S$ ) which some writers have interpreted as being the work that must be done before penetration occurs at all. Formula (3.6) is derived on the assumption that penetration has occurred. Figure 3 then shows that no matter what occurred in the initial stages the damage is related to the absorbed energy by (3.6). Each of Akita's figures for the six tests indicate a gradual increase from the origin of 'work' and 'penetration' with no evidence of an initial constant energy having to be overcome.

### 3.4. Work done in crushing bow structure

The experimental results of Akita and Kitimura are now used to investigate the validity of (2.7). The maximum load calculated in Appendix A of Akita, based on Marguerre's formula for the buckling of stiffened panels, is identified with  $\sigma$  in (2.7). The values for the six bow structures considered are given in Table 4. The energy  $W_b$  in Table 4 was obtained from Akita's records. Values of  $\sigma p_b$ , where  $p_b$  is the penetration of the bow given in Table 1, are given in Table 4.

Figure 4 shows a graph of the experimental values of  $W_b$  versus the calculated values of  $\sigma p_b$ . The figure shows that a linear relationship of the form (2.7) is acceptable. In terms of the units used here, the appropriate relationship is

$$W_b = 0.95 \sigma p_b \quad \text{tons.metres.}$$

## 4. Discussion of Formulae and Comparison with Other Methods

### 4.1. Comparison with Minorsky for penetration by rigid bow

Based on the theoretical analysis of section 2 and the experimental evidence presented in section 3 the following formulae are proposed for calculating the extent of damage in a collision or a grounding.

The kinetic energy absorbed by the side structure or bottom structure of the struck or grounded vessel is given by

Table 4. Max. loads and absorbed energies  
for bow structures

	$W_b$ ton.m.			$\sigma$ ton	$\sigma P_b$		
	p=0.1m	p=.2m	p=.3m		p=0.1m	p=0.2m	p=.3m
T <sub>1</sub>	1.3	2.8	4.9	24	2.40	4.80	7.20
L <sub>1</sub>	2.0	5.6	9.6	35.5	2.22	5.01	8.37
T <sub>2</sub>	1.8	4.8	9.4	48.9	2.44	5.83	9.58
L <sub>2</sub>	1.1	2.3	4.5	49.3	1.34	2.69	4.93
L <sub>3</sub>	0.6	0.8	1.3	49.3	0.62	1.04	1.34
L <sub>4</sub>	0.5	0.7	0.8	72.8	0.81	1.21	1.32

$$W_S = 9.5 V_S + 3.4 A_S \quad \text{ton.m.} \quad (4.1)$$

where  $V_S$  is the volume of material damaged in  $m^2.mm$  and  $A_S$  is the area of torn plate in  $m.mm$ .

Changing to the more useful units of tons-(knots)<sup>2</sup> which Minorsky misleadingly refers to as energy, and which we may think of as weight-kinetic energy denoted by  $G_S$ , then

$$G_S = 352 V_S + 126 A_S \quad \text{tons-(knots)}^2 \quad (4.2)$$

Equation (4.2) then gives a relation between the amount of weight-kinetic energy ( $\frac{1}{2}$  weight x velocity<sup>2</sup>) absorbed by the side structure in terms of the volume  $V_S$  ( $m^2.mm$ ) of damaged material in the side structure and the area of torn plate  $A_S$  ( $m.mm$ ).

If the damage to the side structure is caused by the bow of a colliding ship, then  $V_S$  may be replaced by  $R_T^*/2$  where  $R_T^*$  is a resistance factor of the Minorsky type given by

$$R_T^* = \sum_i p_s^i L_S^i t^i \quad (4.3)$$

In equation (4.3)  $p_s$  is the penetration of the side by the impacting bow and is therefore different to the penetration  $p$  used by Minorsky, which is the relative displacement of the superimposed ships.

As discussed in the introduction Minorsky's results may be expected to be very applicable to collisions involving a rigid bow and a deformable side structure. Any new formulae relating absorbed energy to damaged material should therefore predict

values agreeing with Minorsky for this type of collision problem. Hence the first requirement is to show that (4.2) does agree with Minorsky for rigid bow penetration problems. This is now verified.

Minorsky's formula is

$$G = 176 R_T + 124,000 \text{ ton-knots}^2 \quad (4.4)$$

For penetration of a ship by a rigid bow  $p_S = p$  and  $R_T = R_T^* = 2 V_S$  so that equation (4.2) becomes

$$G = 176 R_T + 126 A_S \text{ ton-knots}^2 \quad (4.5)$$

Consider the collision quoted in Figure 2 of Minorsky for which  $t = 21\text{mm}$ . Taking  $\alpha = 30$  and using (3.3 iii) enables (4.5) to be rewritten as

$$G = 176 R_T + 537 (R_T)^{0.5} \quad (4.6)$$

Equations (4.4) and (4.6) are compared in Figure 5 over the range  $R_T = 0$  to  $10.000 \text{ m}^2\text{mm}$ , this being Minorsky's original range of  $R_T$ . The agreement can be seen to be very good except near the origin where the energy levels are low. Our main concern here is with collisions involving penetration rather than with minor collisions in which energy is mainly absorbed by membrane action of the plate. Neither (4.4) nor (4.6) should therefore be used for minor collisions and the difference near the origin is inconsequential. Note that in varying  $R_T$  in (4.6)

we are keeping the structure constant ( $t = 21\text{mm}$ ) but changing the penetration.

#### 4.2. Comparison with NCRE for LNG collision barrier

A fairly light side protection barrier is obtained by increasing the linear dimensions of the test specimen considered by Akita and Kitamura by a factor of 10.

In practice a critical penetration resulting in damage to an inner tank is of the order of 2-3 metres. Let us examine the collision between the side structure and bow L2 for  $p = 4\text{m}$ , details of which suitably scaled, are obtained from Tables 1 and 2 and are  $p_s = 2\text{m}$ ,  $A_s = 192\text{m}^2\text{mm}$ ,  $2 V_s = R_T^* = 453 \text{ m}^2\text{mm}$ .

The amount of energy absorbed by the side structure in this collision is, according to (4.2)

$$G_s = 80,000 + 24,000 = 104,000 \text{ tons-knots}^2$$

A value for  $G$  (total energy absorbed by the side and the bow) may also be obtained by Minorsky's equation. According to Akita's interpretation the value is

$$\begin{aligned} G &= 179,000 \text{ (side)} + 238,000 \text{ (box)} + 124,000 \\ &= 541,000 \text{ tons-knots}^2 \end{aligned}$$

If we knew a priori the experimental result that 75% of the energy  $G$  is absorbed by the side, Minorsky then gives a value of 406,000 tons-knots for the energy absorbed by the side, almost

four times the value obtained by (4.2). The difference is mainly due to scaling. Had the experimental results been scaled by ten first and then a curve of the form (2.6) fitted, the resulting equation (4.2) would have been

$$G_s = 352 V_s + 1260 A_s$$

giving a value in this case of  $80,000 + 240,000$  i.e.  $320,000$  which is not greatly different from the  $406,000$  obtained by Akita. However, such a manipulation would be wrong. The dimensional analysis interprets scaling correctly and in determining the coefficients  $a$  and  $b$  of (2.6) the experimental results of Akita must be used with the true dimensions. The difference between the two numbers  $G_s = 104,000 \text{ ton-knots}^2$  obtained by (4.2) and  $G_s = 406,000 \text{ ton-knots}^2$  obtained by Akita's interpretation of Minorsky's method cannot be eliminated.

A different interpretation of Minorsky's method which gives a result agreeing with (4.2) has been given by Haywood<sup>(5)</sup> at NCRE. He calculated a value of  $R_T^*$  based on the true penetration of the side structure and takes as the absorbed energy

$$G_s = 176 R_T^* + 124,000 \text{ tons-knots}^2$$

He then estimates the amount of the total energy absorbed by the side structure. For the case considered he takes this estimate to be 75%, thus

$G_s = 0.75 E$ , where  $E$  is the kinetic energy available to cause damage.

Haywood considers a fairly well-protected side structure for which  $\alpha = 30$  (60 bow-angle) and  $R_T^* = 864 \text{ m}^2 \text{ mm}$ , (16.5 cubic feet). The energy absorbed according to him is therefore  $G_s = 176 \times 864 + 124,000 = 276,000$  ton-knots<sup>2</sup>.

If we now double the amount of plating in L2 so that it becomes a very heavy side-structure, but keep the penetration the same,  $R_T^*$  changes from 453 to 906  $\text{m}^2 \text{ mm}$  (close to the Haywood value) and  $A_s$  changes from 453 to 906  $\text{m}^2 \text{ mm}$ . The amount of energy absorbed according to (4.2) is therefore 208,000 ton-knots (c.f. Haywood 276,000). Akita would now give

$$\begin{aligned} G &= 179,000 \times 2 \text{ (side)} + 238,000 \times 2 \text{ (bow)} + 124,000 \\ &= 958,000 \text{ ton-knots} \end{aligned}$$

This is three and a half times Haywood's value and four times that of (4.2). In terms of evaluating the critical velocity for penetration up to the inner tank, the 25% difference between the energy levels of Vaughan and Haywood will reduce to a 12% difference in velocities, quite within the magnitude that might be expected since two different structures are involved in the comparison.

#### 4.3. Grounding with significant plate tearing

As discussed in the introduction, many groundings result in significant tearing of the bottom plating with very little volume of destroyed material.

If we consider the limiting case of a long narrow slit in the bottom plating such as shown in figure 1, equation (4.2) gives

$$G_s = 126 \times t \times l \text{ tons-knots}^2 \quad (4.7)$$

where  $t$  is the bottom plate thickness in mm and  $l$  is the length of the slit in metres.

Minorsky's equation, if applied to this problem would give  $G_s = 124,000$  tons-knots, irrespective of the extent of the damage. Minorsky did not intend that his equation should be used for such problems and therefore discussion and criticism of it is not in order. On the other hand equation (4.2) may be applied to such problems to obtain estimates of the energy absorbing qualities of bottom structures. A detailed example of such a calculation is included in section 5 of this paper.

##### 5. EXAMPLE - Grounding of LNG Carrier

The LNG carrier considered is presently being constructed in Sweden and is of the membrane design rather than the spherical tank Moss-Rosenberg design. In this investigation we limit attention to a head on collision between the ship and a fixed sharp object such as a reef or an ice-floe projection, it being assumed that the ship runs over the obstacle without change of draft.

The general arrangement of the bow is shown in Figure 6 and the transverse sections with LNG tank profile is shown in Figure 7. The plate thickness of the hull is shown in Figure 8. The problem is to estimate the minimum forward speed of the ship so that if it strikes a sharp object in the forward part, then penetration will be limited to the ship, with no damage to the LNG tank. Such information will enable safe speeds to be established so that in the event of the ship having to operate in areas where grounding or ice penetration may occur, critical damage to the LNG tank cannot occur.

The profile of the projecting object which causes penetration is taken to be triangular. It is shown in the critical damage position in Fig. 7. If the object is further from the ship centre line than shown then the tank will not be damaged whereas if it is closer to the centre line penetration will occur further forward with a corresponding increase in resistance to damage. Figure 7 shows that penetration occurs near frame 367. The asterisk in Figure 6 locates the penetration in the longitudinal direction. It is immediately apparent that the penetration is very much closer to the tank than might be expected. The bulbous bow and strong stem of the ship do not contribute to the protection of the tank for this type of grounding since the sharp object, in the critical case, is able to pass the bow without contact.

Three values of  $\theta$  have been considered,  $15^\circ$ ,  $30^\circ$  and  $45^\circ$ . In each case penetration occurs at frame 367 and is critical

when it extends aft to frame 357 (plus 40 cm. for insulation of the tank). With a frame spacing of 0,8m this gives a tear length of 8.4m.

The outer shell thicknesses are indicated in Figure 8. The inner bottom extends aft from frame 364 and is 18mm thick. The outer shell stiffeners give an effective increase in shell thickness of 10.5mm and the inner bottom stiffeners give an increase in thickness of 10mm. The only other major structural element which resists penetration from the bow is a vertical girder 19mm thick, 5.64m from the ship centre line, starting at frame 364 and running aft.

#### Area of torn plate

From frames 357 to 361 the plate thickness (excluding stiffening) is 22mm and from 360 to 367 it is 20mm. The area of torn bottom plate is therefore  $3.6 \times 22 + 4.8 \times 20 = 175\text{m.mm}$ . The 18mm inner bottom is penetrated from frames 364 to 357 so that the torn area is  $6 \times 18 = 108\text{m.mm}$ . The total area of torn plate is therefore 283 m.mm.

#### Volume of damaged material

A long triangular section of bottom plate is damaged as shown in Figure 9.a. Including stiffeners, the plate thicknesses are 30.5mm and 32.5mm as shown. The following simple formulas are used to find the volume  $V_1$  and  $V_2$ :

Table 5. Areas of torn plate, volumes of damaged material and velocities for critical penetration

$\theta$	15	30	45
A m.mm	283	283	283
L <sub>1</sub> m	1.3	2.7	4.5
L <sub>2</sub> m	1.1	2.3	4.2
V <sub>1</sub> m <sup>2</sup> .mm	132	275	478
V <sub>2</sub> m <sup>2</sup> .mm	86	179	328
V <sub>3</sub> m <sup>2</sup> .mm	36	78	134
L <sub>3</sub> m	0	1.8	1.9
L <sub>4</sub> m	0	0.8	1.0
V <sub>4</sub> m <sup>2</sup> .mm	0	148	165
V m .mm	254	680	1105
V knots	1.5	2.3	2.8

$$V_1 = 30.5 \times 3.6 \times (L_1 + L_2)/2 \quad \text{m.mm}$$

$$V_2 = 32.5 \times 4.8 \times L_2/2 \quad \text{m.mm}$$

Values of  $L_1$ ,  $L_2$ ,  $V_1$  and  $V_2$  for each of the three  $\theta$  are given in Table 5.

The volume of the damaged inner bottom running from frames 357 to 364, shown in Figure 9.b., is seen to be

$$V_3 = 6 \times 28 \times 0.8 \tan\theta$$

Values of  $V_3$  are given in Table 5.

Finally the damage to the girder 5.64m from the ship centre line is calculated for each  $\theta$ . The volume, shown in Figure 9.c., is  $V = 6 \times 19 \times (L_3 + L_4)/2$ . Values of  $L_3$ ,  $L_4$  and  $V_4$  are given in Table 5.

The total volumes of damaged material are

$$V = V_1 + V_2 + V_3 + V_4$$

The energy absorbed by the bottom structure, according to (4.2) is

$$G = 352 V + 126 A \quad \text{tons-knots}^2$$

Assuming that all the kinetic energy of the ship is lost in the grounding the critical penetration velocities  $v$  are given by

$$\frac{1}{2} \nabla v^2 = G$$

where  $V = 107,000$  tons, is the displacement of the ship.

Values of  $v$  are given in Table 5. They are somewhat lower than expected because initial penetration occurs so far aft, quite close to the LNG tank. There is then relatively little structural material to resist further penetration by an object of this type.

Other grounding problems likely to occur when the ship is drifting or manoeuvring, involving collision with locally spherical objects, as shown in Figure 10, have been considered recently by Johnsen and Vaughan<sup>(7)</sup>.

### Conclusion

A method is presented which enables damage estimates to be made when considering the collision and grounding of ships. The method is based upon a formula which relates the work required to do the damage (lost kinetic energy) to the amount of damage caused. This damage is decomposed into two separate parts; the volume of damaged material and the area of torn plate. The formula is derived from dimensional considerations and introduces two coefficients associated with the parts of the decomposed ship damage.

A series of tests conducted in Japan on small scale grillages verify that the proposed formula is functionally correct and enables specific values to be assigned to the coefficients in the formula. The method is shown to agree with Minorsky for conventional ship-collision problems and also

with some calculations conducted at NCRE for LNG collision-barrier strength-estimates. The method has a new feature in that it may be used for estimating damage due to grounding in which there may be significant plate tearing. No other method has been presented for examining such problems.

The paper concludes by considering a particular LNG tanker of the membrane-tank design running over a hypothetical sharp object. The object is representative of a sharp reef or ice-floe tip. A critical situation is examined in which the ice-floe tip may by-pass the bulbous bow of the tanker leaving the leading LNG tank relatively unprotected and vulnerable to critical penetration. Using the proposed method, safe operating speeds are deduced so that in the event of such a grounding, damage will be confined to the ship structure leaving the LNG tanks intact. Because of the relatively small-amount of protective material in the ship bottom, forward of the leading LNG tank, the safe operating speeds are found to be quite low.

#### Acknowledgements

This work was mainly carried out whilst the author was visiting Det norske Veritas during the spring and summer of 1977. The author is indebted to Dr. H.R. Hansen of DnV for making the necessary arrangements and for encouraging the author to investigate the problem of ship grounding.

During this period the author was on leave from the University of British Columbia, Vancouver.

References

- (1) Minorsky, V.U.: "An Analysis of Ship Collision with Reference to Protection of Nuclear Power Plants", Journal of Ship Research, Vol.3., 1959, pp 1-4.
- (2) "Plastic and Limit Design", Committee Report 3e, Proc. 3rd Int. Ship Structures Congress, Oslo, Vol.1, 1967 pp 288-290.
- (3) Woisin, G. : "Schiffbauliche Forschungsarbeiten fur die Sicherheit kernenergiegetriebener Handelsschiffe", Jahrbuch der Schiffbautechnischen Gesellschaft, 65 Band, 1971, pp 225-263.
- (4) Akita, Y. and Kitamura, K.: "A Study on Collision by an Elastic Stem to a Side Structure of Ships", J. Soc. Nav. Arch. Japan, Vol. 131, 1972, pp 307-317.
- (5) Haywood, J.H.: "A Note on Collision Estimates for LNG Carriers," NCRE Report, Feb. 1971.
- (6) Card, J.C., "Effectiveness of Double Bottoms in Preventing Oil Outflow from Tanker Bottom Damage Incidents," Marine Technology, 1975, pp 60-64.
- (7) Johnsen, K. and Vaughan, H. "Estimates for Damage to a Large LNG Carrier due to Collision and Grounding," Det norske Veritas Report. Aug. 1977.

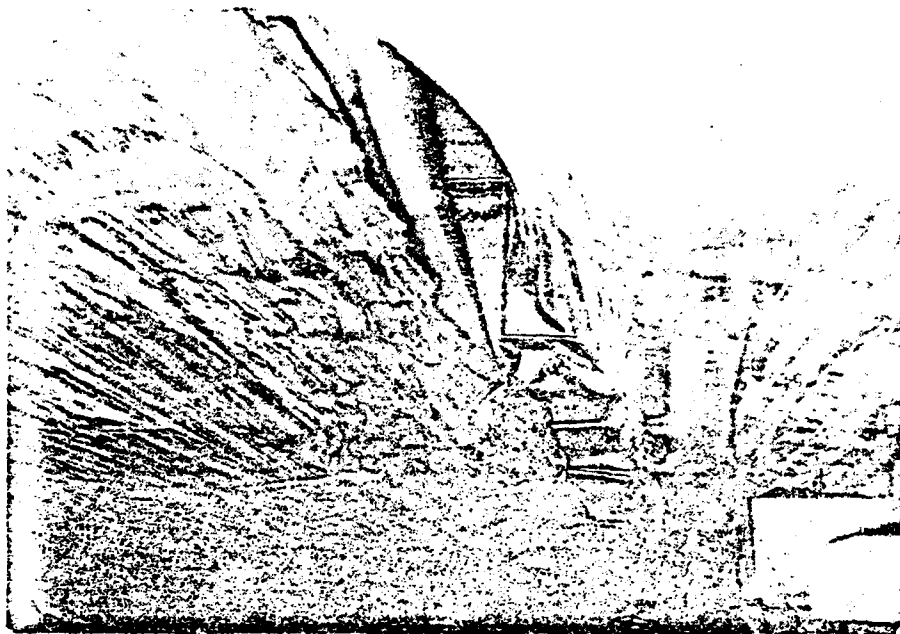

Fig. 1. Torn bottom-plating of ship due to grounding.

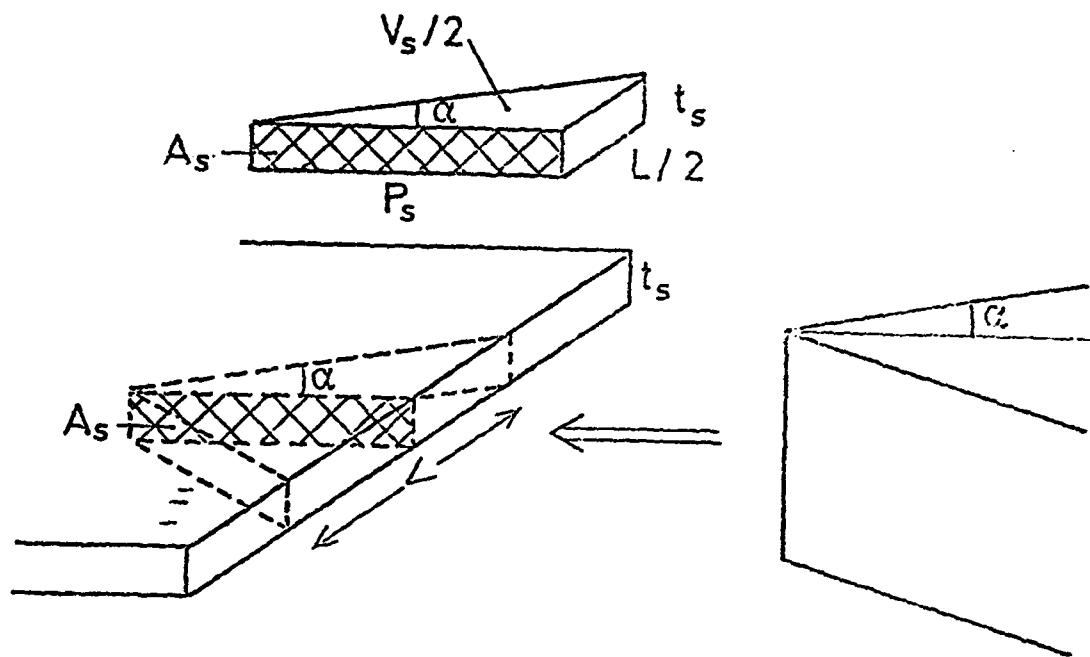
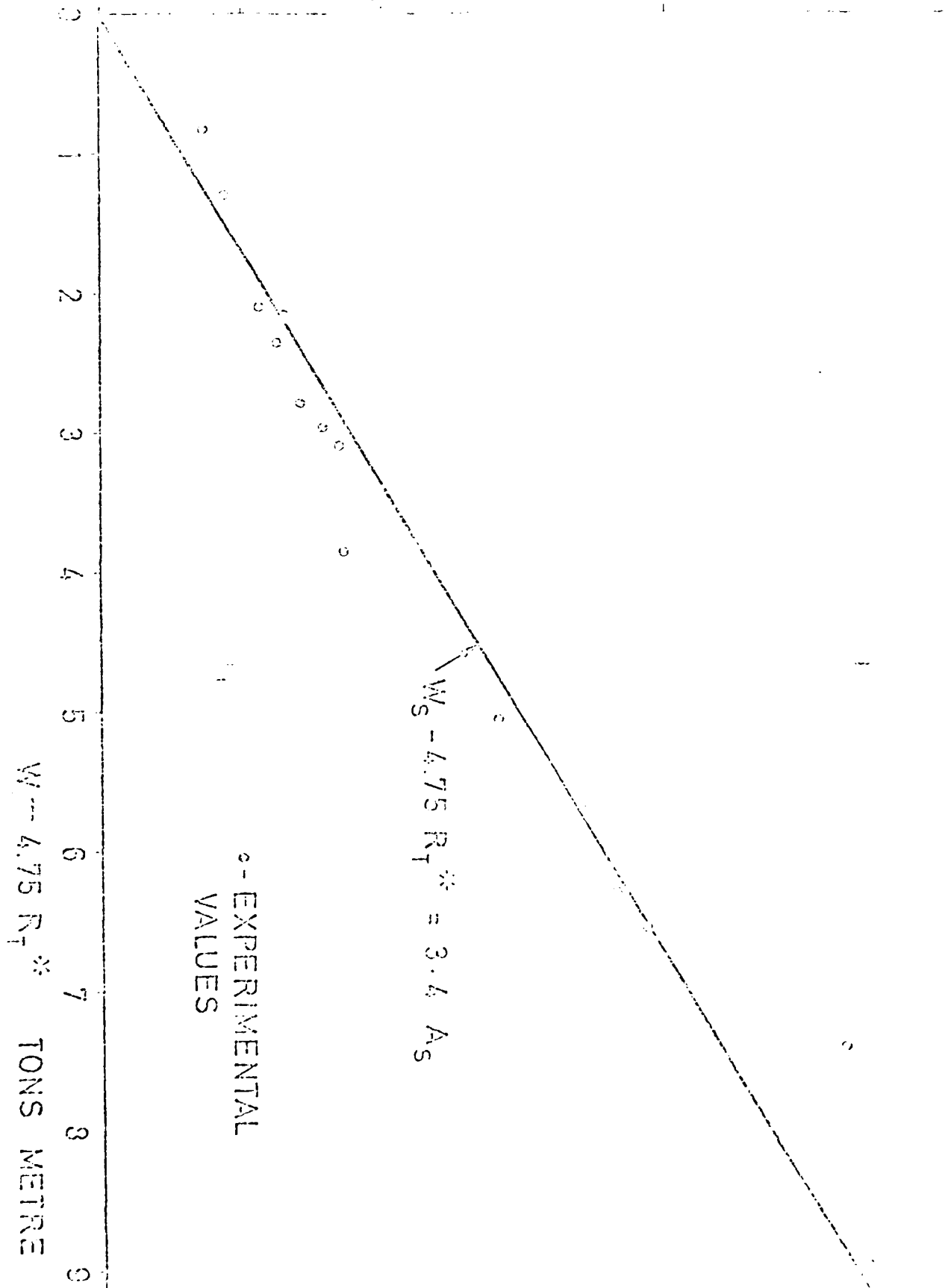

Fig. 2. Penetration of plate by wedge.



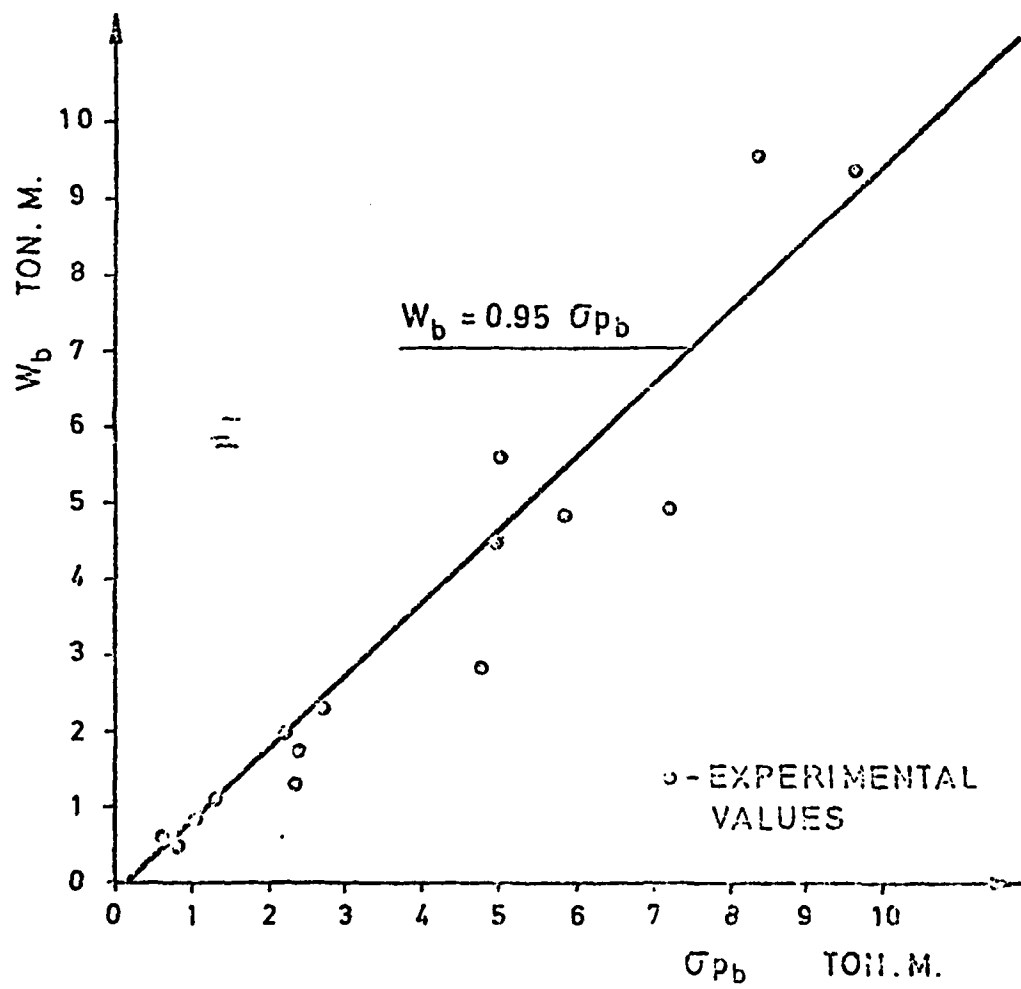

Fig. 4.  $W_b$  versus  $\sigma_{pb}$

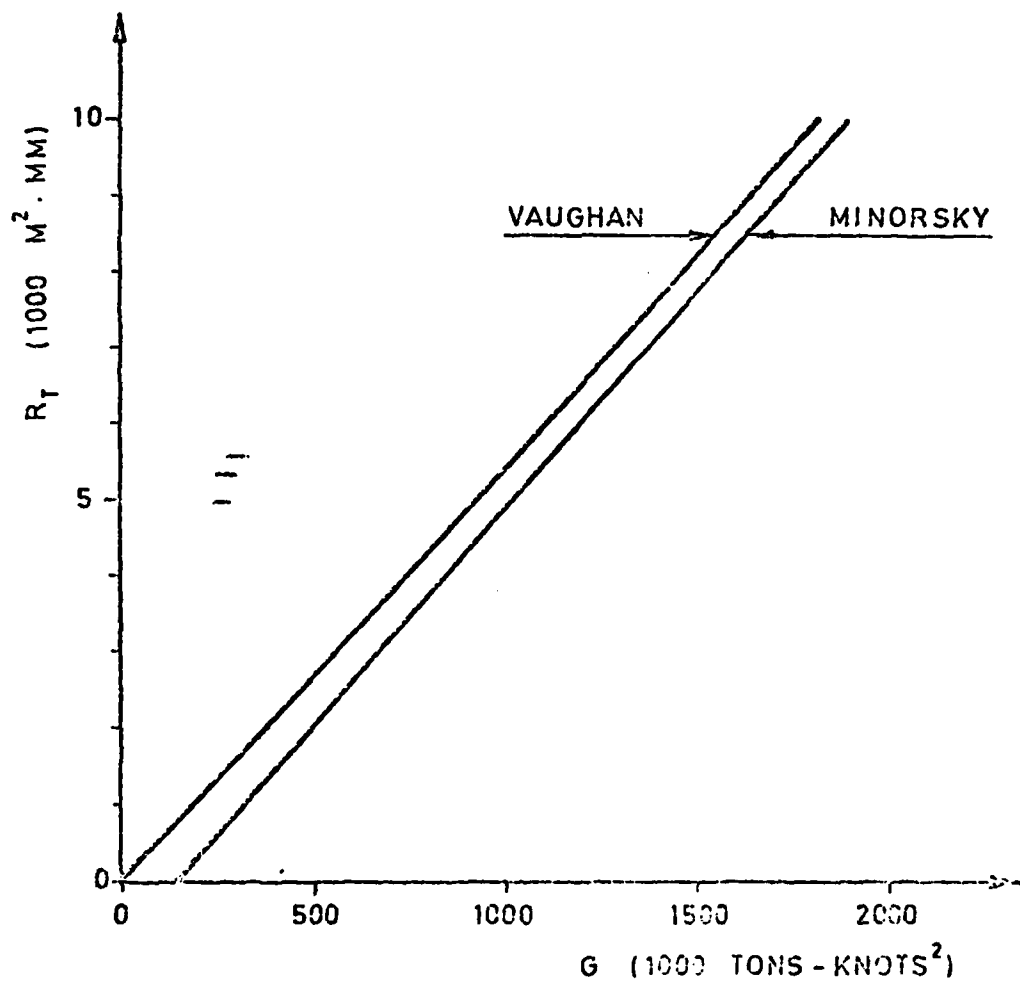
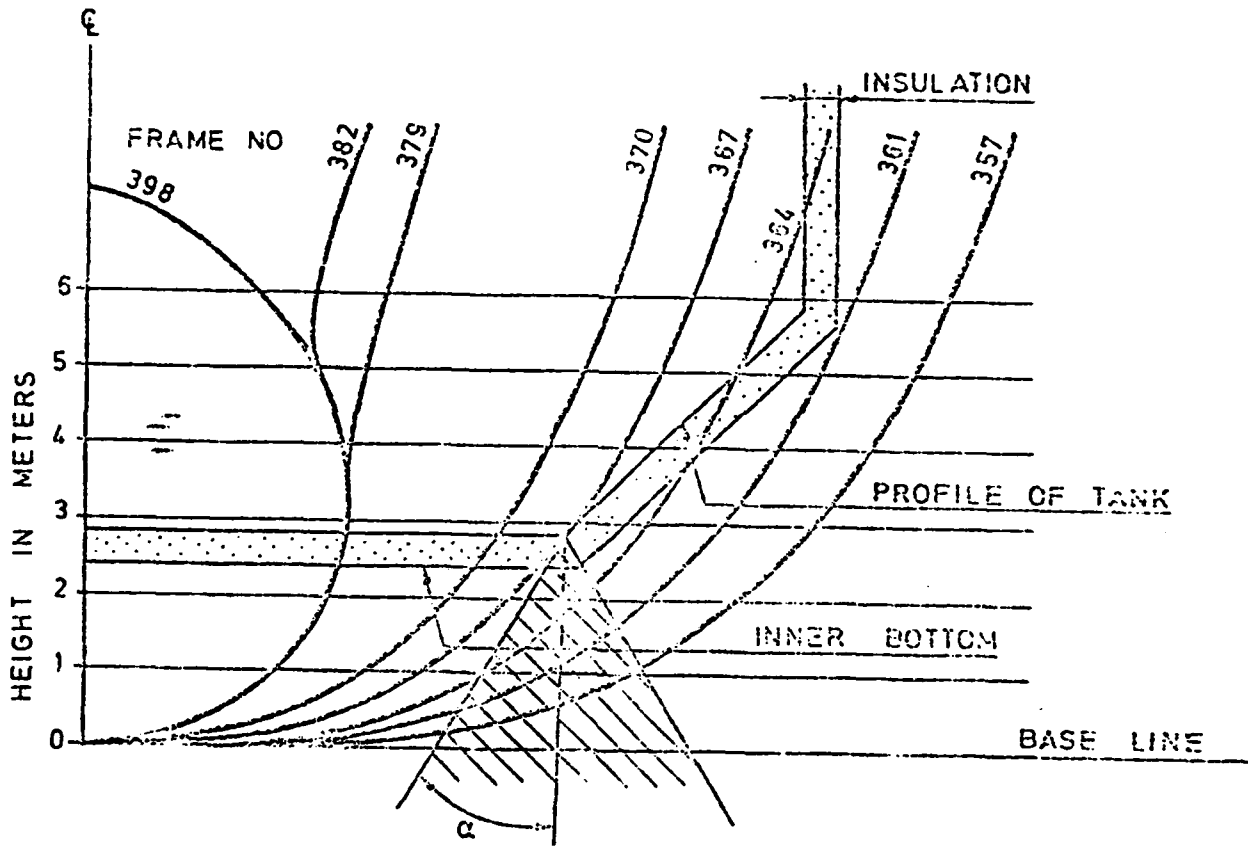

Fig. 5. Comparison of methods for penetration of side structure by rigid law.



Copy available to DTIC does not permit fully legible reproduction



Copy available to DTIC does not permit fully legible reproduction

Fig. 7. Transverse section of bow, profile of leading LNG tank, and profile of penetrating object.

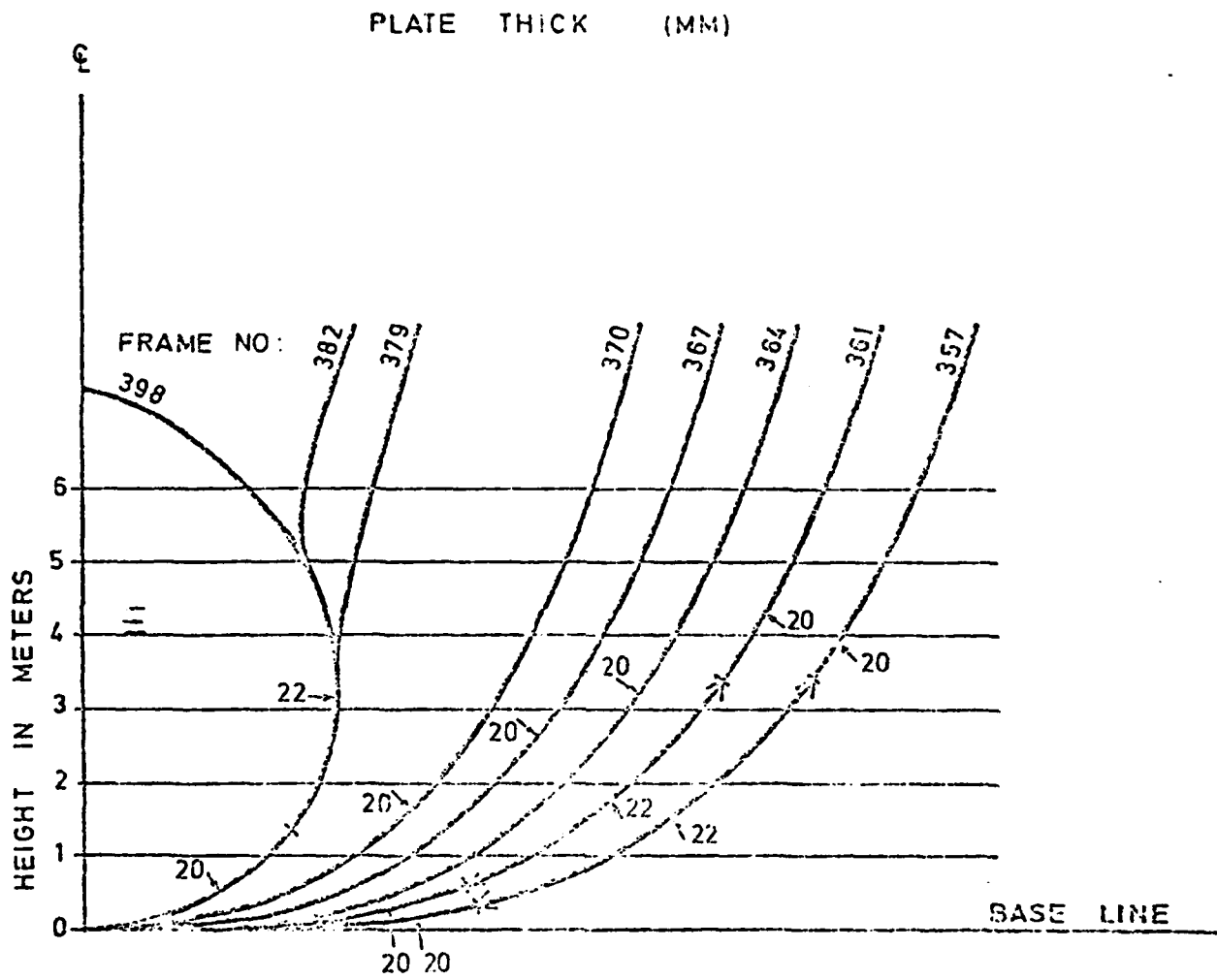

Copy available to DTIC does not permit fully legible reproduction

Fig. 8. Plate thickness curves for various frame numbers

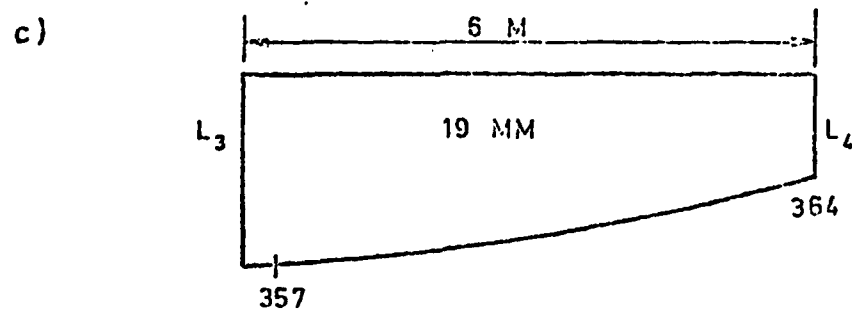
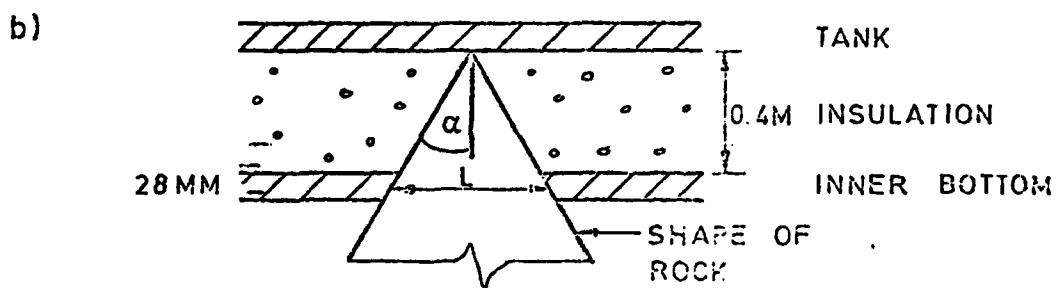
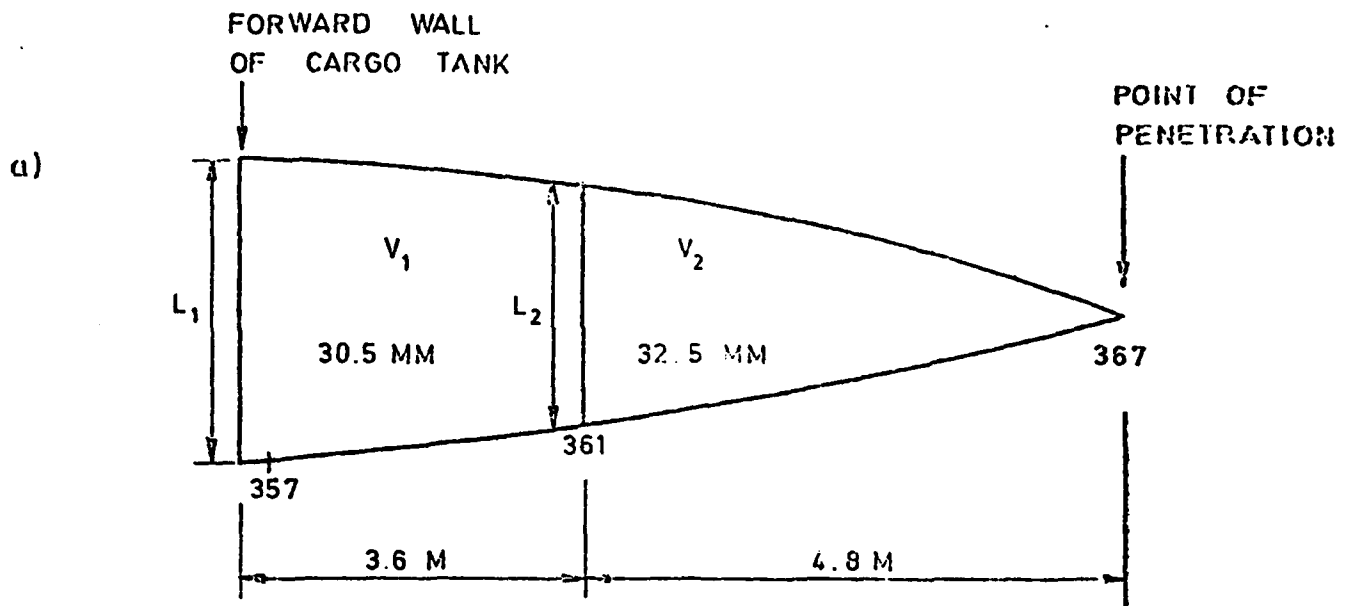

Copy available to DTIC does not permit fully legible reproduction

Fig. 9. Material damaged in grounding:  
 a) bottom plating,  
 b) inner bottom,

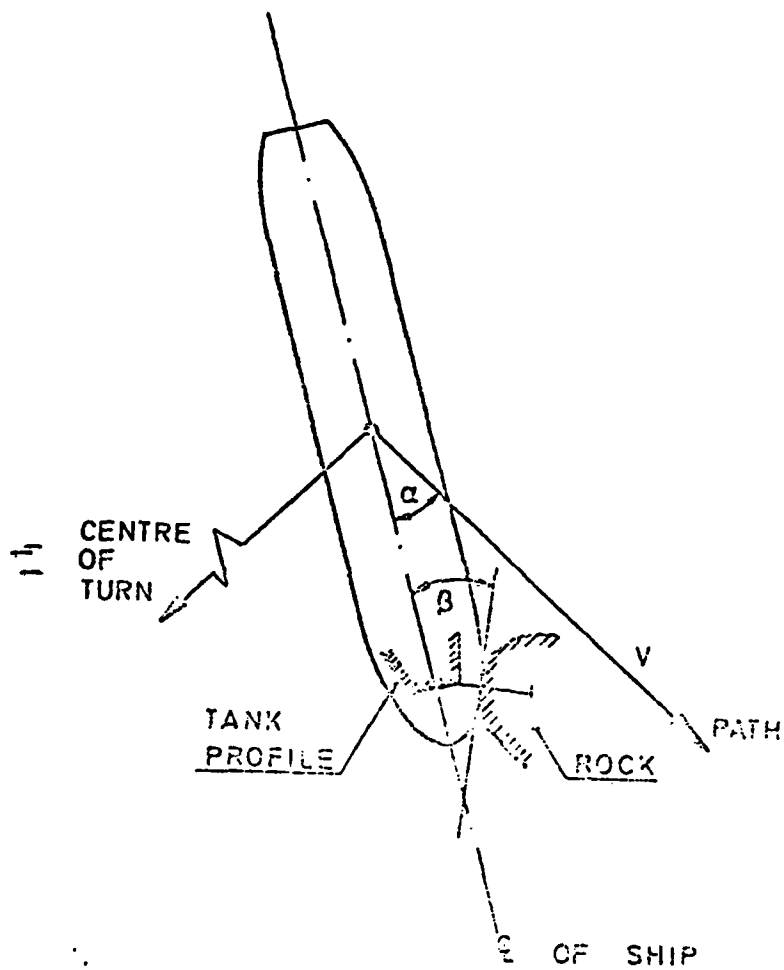

Copy available to JTIC does not  
 permit fully legible reproduction

Fig. 10. Collision of ship with rock occurring during  
 maneuvering of ship.