

AD-A117 552 ROCKWELL INTERNATIONAL LOS ANGELES CA LOS ANGELES AI--ETC F/G 1/2  
INVESTIGATION OF AIRCREW PROTECTION DURING EMERGENCY ESCAPE AT --ETC(U)  
MAY 82 R J CUMMINGS F33615-80-C-0513

UNCLASSIFIED NA-80-871

AFAMRL-TR-81-71

NL

1 of 1

AD A

107832

END  
DATE  
FILMED  
09-82  
DTIC

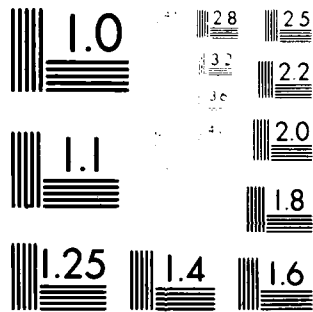

MICROCOPY RESOLUTION TEST CHART  
NATIONAL BUREAU OF STANDARDS-1963-A

AD A117552

AFAMRL-TR-81-71



**INVESTIGATION OF AIRCREW PROTECTION DURING  
EMERGENCY ESCAPE AT DYNAMIC PRESSURES UP TO 1600 G**

**ROBERT J. CUMMINGS**  
**ROCKWELL INTERNATIONAL**  
**NORTH AMERICAN AVIATION DIVISION**  
**815 LAPHAM STREET**  
**LOS ANGELES, CA 90009**

**MAY 1982**

Approved for public release; distribution unlimited

DTIC FILE COPY

**AIR FORCE AEROSPACE MEDICAL RESEARCH LABORATORY**  
**AEROSPACE MEDICAL DIVISION**  
**AIR FORCE SYSTEMS COMMAND**  
**WRIGHT-PATTERSON AIR FORCE BASE, OH 45433**

**DTIC**  
**ELECTE**  
**JUL 29 1982**  
**S D**  
**D**

82 07 28 082

## NOTICES

When US Government drawings, specifications, or other data are used for any purpose other than a definitely related Government procurement operation, the Government thereby incurs no responsibility nor any obligation whatsoever, and the fact that the Government may have formulated, furnished, or in any way supplied the said drawings, specifications, or other data, is not to be regarded by implication or otherwise, as in any manner licensing the holder or any other person or corporation, or conveying any rights or permission to manufacture, use, or sell any patented invention that may in any way be related thereto.

Please do not request copies of this report from Air Force Aerospace Medical Research Laboratory. Additional copies may be purchased from:

National Technical Information Service  
5285 Port Royal Road  
Springfield, Virginia 22161

Federal Government agencies and their contractors registered with Defense Documentation Center should direct requests for copies of this report to:

Defense Documentation Center  
Cameron Station  
Alexandria, Virginia 22314

### TECHNICAL REVIEW AND APPROVAL

AFAMRL-TR-81-71

This report has been reviewed by the Office of Public Affairs (PA) and is releasable to the National Technical Information Service (NTIS). At NTIS, it will be available to the general public, including foreign nations.

This technical report has been reviewed and is approved for publication.

FOR THE COMMANDER

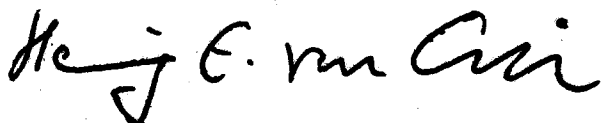

**HENNING E. VON GIERKE**  
Director  
Biodynamics and Bioengineering Division  
Air Force Aerospace Medical Research Laboratory

REPORT DOCUMENTATION PAGE		READ INSTRUCTIONS BEFORE COMPLETING FORM
1. REPORT NUMBER AFAMRL-TR-81-71	2. GOVT ACCESSION NO. AD-A117552	3. RECIPIENT'S CATALOG NUMBER
4. TITLE (and Subtitle) INVESTIGATION OF AIRCREW PROTECTION DURING EMERGENCY ESCAPE AT DYNAMIC PRESSURES UP TO 1600 Q	5. TYPE OF REPORT & PERIOD COVERED Final Technical Report	
	6. PERFORMING ORG. REPORT NUMBER NA-80-871 ✓	
7. AUTHOR(s) Robert J. Cummings	8. CONTRACT OR GRANT NUMBER(s) F33615-80-C-0513	
9. PERFORMING ORGANIZATION NAME AND ADDRESS North American Aircraft Division P.O. Box 92098 Los Angeles, CA 90009	10. PROGRAM ELEMENT PROJECT, TASK AREA & WORK UNIT NUMBERS 62202F 7231-13-08	
11. CONTROLLING OFFICE NAME AND ADDRESS Air Force Aerospace Medical Research Laboratory, Aerospace Medical Division, Air Force Systems Command, Wright-Patterson Air Force Base, Ohio 45433	12. REPORT DATE May 1982	
	13. NUMBER OF PAGES 72	
14. MONITORING AGENCY NAME & ADDRESS (if different from Controlling Office)	15. SECURITY CLASS. (of this report) Unclassified	
	15a. DECLASSIFICATION DOWNGRADING SCHEDULE	
16. DISTRIBUTION STATEMENT (of this Report)  Approved for public release; distribution unlimited		
17. DISTRIBUTION STATEMENT (of the abstract entered in Block 20, if different from Report)		
18. SUPPLEMENTARY NOTES		
19. KEY WORDS (Continue on reverse side if necessary and identify by block number)  aircraft escape systems, ejection seats, flai y		
20. ABSTRACT (Continue on reverse side if necessary and identify by block number) A perspective is developed on requirements for applied biomechanical research necessary to support development of new advanced escape capability for negative static stability margin aircraft. Processes which govern potentially injurious energy transfers to and from the ejectee are enumerated. Four escape design approaches are evaluated in terms of energy transfers, protection strategies, and research requirements, including (1) advanced open upright seat, (2) reclined open, (3) partially encapsulated, and (4) encapsulated.		

**BLANK PAGE**

## SUMMARY

The biomechanical research efforts required to support the development of each of four alternative escape system design approaches for crew protection during escape from advanced high performance aircraft are discussed. A separable forebody incorporating a conventional ejection seat presents the least biomechanical risk and would require the least new biomechanical research. Three other alternative designs, all open seats, employ vertical separation from the aircraft. All require large biomechanical research programs to develop protection equipment. A reclined seat presents the least biomechanical risk, followed by the partially encapsulated upright and the advanced conventional upright seats. The discussions include:

- Biomechanically significant energy transfers during escape
- Advanced aircraft performance and escape requirements
- Acceleration and windblast protection concepts for advanced conventional, reclined, partially encapsulated, and fully encapsulated escape systems
- Biomechanical research requirements for each design approach
- A concise definition of the biotechnology problem for escape up to 1,600 psf and under aircraft maneuvering loads

Accession For	
NTIS GRA&I	<input checked="" type="checkbox"/>
DTIC TAB	<input type="checkbox"/>
Unannounced	<input type="checkbox"/>
Justification	
By _____	
Distribution/	
Availability Codes	
Dist	Avail and/or Special
A	



## TABLE OF CONTENTS

	Page
INTRODUCTION	5
Scope	5
Report Organization	6
BACKGROUND	7
High-Q Escape - Energy-Damage Prevention Problem	7
CONCEPTUALIZED ADVANCED AIRCRAFT	36
Escape Design - Function Integration Problem	37
Escape From a Nonclassical Aircraft	39
FOUR APPROACHES TO ADVANCED ESCAPE SYSTEM DESIGN	44
Advanced Conventional	44
Reclined Seat	47
Partial Encapsulation	48
Full Encapsulation	50
ANALYSIS OF BIOMECHANICAL RESEARCH REQUIREMENTS	52
Advanced Conventional	52
Reclined	57
Partial Encapsulation	61
Full Encapsulation	62
BIOTECHNOLOGY PROBLEM DEFINITION	63
REFERENCES	66

## LIST OF ILLUSTRATIONS

Figure	Title	Page
1	Generalized Escape Energy Transfer Model	9
2	Conceptualized Interaction Between Man and Airmass	13
3	Stagnation Canopy for Helmet Retention During High-Speed Ejections	14
4	Torso Airflow Stagnation Fence Arm Restraints	16
5	Upper Torso Support Restraint Garment	21
6	Multiaxial Pelvis Restraint	22
7	Paired Yaw Moment Drogues on Attitude Controller Braked Wire Reels	22
8	Reclined Escape System	24
9	Leg Restraint Integrated With Anti-G Suit	30
10	Conceptual Probability Distribution of Ejection Environments	38
11	Operational Envelope for Advanced Conceptual Aircraft	38
12	Ejection Seat Side Load Factor Versus Velocity	41
13	Partial Encapsulation Concept	49
14	Attitude for Greatest Combined Drag and Separation Forces on a Conventional Seat	56
15	Normal and Maximum Force Ejection Modes for a Conventional Seat	56
16	Reclined Seat Separation From a Maneuvering Aircraft	59

## LIST OF TABLES

Table	Title	Page
1	Relative Significance of Energy Paths to Four Escape Design Approaches Within Four Biomechanical Problem Areas	53
2	Summary of Biomechanical Research Programs for Four Escape Design Approaches	65

## PREFACE

This report covers work performed under Contract F33615-80-C-0513 from 19 May 1980 to 22 February 1981. The work was done at the Los Angeles facilities of the North American Aircraft Division of Rockwell International Corporation, 815 Lapham Street, El Segundo, California 90009. Robert J. Cummings, Human Engineering/Biomedical Group in the Systems department, was the program manager and principal investigator.

The Air Force technical monitor was James W. Brinkley, Biomechanical Protection Branch, Biodynamics and Bioengineering Division of the Air Force Aerospace Medical Research Laboratory.

Assistance in this investigation was provided by Gilbert R. Casteel, Aerodynamics Group, and Waren M. Gran, Escape Group.

## INTRODUCTION

Conceptualized advanced high-performance air vehicles represent new and difficult technical challenges to the planners and designers of escape systems. These challenges include the wide ranges of environmental stresses imposed by the operational and emergency flight conditions associated with these vehicles. The strategy to meet these challenges involves the decision to either maintain the present direction of escape system evolution (i.e., gradual improvement of the open ejection seat) or to pursue a more aggressive program directed toward major improvements in escape system technology and system design. The objective of this research has been to investigate the aeromedical aspects of this problem. Special emphasis has been given to the investigation of aircrew protection at dynamic pressure levels up to 1,600 psf. The influence of escape system design approach and air vehicle configuration have been studied since these will be critical to the selection of an overall research program strategy and, eventually, to the choices of personnel protection concepts. Refer to Belk (1980), Dobbek (1980), Harrison (1980), Peters (1980), Santi et al. (1979), Tyburski et al. (1980), and Walker et al. (1977).

### SCOPE

This research investigation included an analysis of advanced aircraft systems requirements and four alternative conceptual escape system configurations that will meet these requirements. It also included an analysis of biomechanical problems associated with these escape systems, development of technical approaches to their solution, and a detailed investigation of personnel protection to dynamic pressure levels of 1,600 psf. Finally, this research included a comparative study of the levels of effort in applied biomechanical research required for each of four different escape design approaches.

The principle objective was the investigation of biomechanical research requirements for advanced escape systems. Within this context, an organizing theme was the use of the earth-based reference frame for discussing biomechanically significant energy transfers during the escape sequence. While design development was not a principle goal of this report, discussions of specific design solutions are included because they help to focus attention on the need for applied biomechanical research to support new escape system design efforts. Therefore, the design solutions proposed in this report should be considered as exercises that lend insight into practical biomechanical problems in escape design, not as serious design proposals.

The Air Force advanced escape system (ACES-II) served as the baseline escape system for this investigation.

## REPORT ORGANIZATION

This report contains an extensive background section focusing on energy transfer processes that produce biomechanical stresses in the seat occupant during escape. Some protection concepts are introduced, but only to illustrate how the strategy behind their designs derives from the energy transfer analysis technique. A map of energy transfer paths facilitates both analysis of the escape problem into more fundamental processes and synthesis of interrelated biomechanical stress processes into integrated protection design strategies. Sixteen energy transfer paths and several protection concepts are described in the background section.

Following the background section, a section on conceptualized advanced aircraft identifies some important and particular escape environments associated with computer controlled configuration combat aircraft. Two subsections present discussions of the probable implications of these environments for escape system designs both for support and restraint of the body during flight and for escape and recovery from a disabled aircraft.

The next section presents in four subsections the physical and functional characteristics of four approaches to advanced escape system design. These four approaches represent four general classes of solutions to the multiple tradeoff problem generated by conflicting man centered, engineering, operational and environmental constraints on the escape system design problem.

Next, the biomechanical research requirements implicit in each of the four design approaches are discussed in four subsections in the context of the sixteen energy transfer paths and four generalized escape problem areas, windblast, repositioning, aircraft motions, and response to escape system stabilization forces and moments. The final section summarizes the biotechnology problem presented by the need to choose an escape system design approach appropriate for the next generation of advanced combat aircraft.

## BACKGROUND

Advanced conceptual fighter aircraft and, to a significant extent, recently developed Air Force operational aircraft present flight conditions for which current escape systems are not designed. Use of even the most advanced operational ejection seat under these flight conditions will result in a risk of fatality and major injury far in excess of current operational experience. The increased risk is the indirect result of advanced flight maneuvering capabilities, design approaches which result in air vehicles with negative stability margins, unconventional cockpit configurations, and higher cruise speeds.

Unilateral advancement in escape system technology areas, such as windblast protection or acceleration protection, is difficult and sometimes undesirable, since major advancement is dependent on the state of other technology areas, such as escape system stability and propulsion. Therefore, this investigation considered the interactions between the technical approaches in the major areas of escape system design and the environmental stresses.

In preparation for characterizing these interactions, an inventory of environmental stresses during escape was made. The concept of energy damage was the organizing principle for this inventory. Accordingly, the classification scheme for the inventory is based on the paths by which energy is transferred between the mass elements involved in an escape. This classification scheme resulted in identification of 16 different energy transfer paths. Discussions of each of these paths are presented. In some of these discussions, examples of the interactions between selected protection design approaches and the subject energy transfer are included. The protection designs thus introduced are incorporated into complete escape system configurations in later sections of this report.

The discussion of interactions between approaches and environmental stresses is followed by a few brief examples of energy damage injuries which may result from energy transfers during escape. Next is a short discussion of some important external constraints on escape system designs, in particular, maneuver load stress alleviation. This background section is then closed with a discussion of the principal factors which determine the probability that an aircraft would be out of control at ejection initiation, and the problems of escaping from a maneuvering aircraft.

### HIGH-Q ESCAPE - ENERGY-DAMAGE PREVENTION PROBLEM

Haddon (1973) argued that all situations carrying the potential for human injury can be analyzed in terms of energy transfers to, from, or within the body. The application of this approach to the high-Q escape situation offers advantages for the purpose of this study; i.e., identifying, categorizing, and describing biotechnology problem areas in the development of advanced escape systems. An energy transfer analysis must identify the primary energy sources and sinks, transfer paths, events or situations causing each energy transfer, and possible consequences of the identified energy transfers regarding the

safety of the ejectee. Having thus identified the energy-damage problem areas in high-Q escape, alternative approaches to the design of advanced escape systems can be evaluated in terms of the comprehensiveness of the energy-damage prevention strategies they employ. Then each strategy also can be reviewed for its implicit dependence on biomechanical data. Finally, existing basic biomechanical research data must be compared with the new data requirements to identify the need for new applied biomechanical research programs.

An energy transfer model also can aid in studying design complications introduced by:

- Constraints other than energy-damage prevention
- Constraints on biomechanical research projects which require dealing with only an isolated part of the energy transfer process

A descriptive energy transfer model has an advantage over more detailed computer math models which also describe this process. The math models are typically too complex to be discussed broadly and are difficult to manipulate. Therefore, these models are of little benefit to most of the escape biomechanics research community in their group effort to transmit comprehensible escape design requirements to the escape system design community.

Among constraints other than energy-damage prevention are the special body support/restraint requirements of highly maneuverable aircraft. Designs, such as the pelvis and leg elevating (PALE) seats, fixed reclined seats, or pressurized vests, are viable concepts for high sustained acceleration stress alleviation through maintenance of cerebral blood pressure. Control/display access, external vision, weight, bulk, and complexity are also important design drivers not related to energy-damage prevention.

Biomechanical research projects limited to simulations of isolated parts of the energy transfer process include those using wind tunnels, rocket sleds, or water tanks to study the man-to-airmass energy transfer process. Each one leaves out a part of the whole energy transfer picture, such as dynamic inertial response to deceleration, or the effect of booster rocket thrusting, or the effect of the aircraft flow field on the escape system aerodynamics.

The major sources and recipients of the energy transfers which take place during escape are the four mass elements involved in the escape process; the airmass, aircraft, escape system, and man.

#### Four Mass Elements

During high-Q escape, important energy transfers take place among the four primary mass elements, including the airmass or atmosphere, aircraft, escape system, and man. Important energy transfers also take place among mass elements of the man's body. Figure 1 is a schematic interpretation of the four primary mass elements.

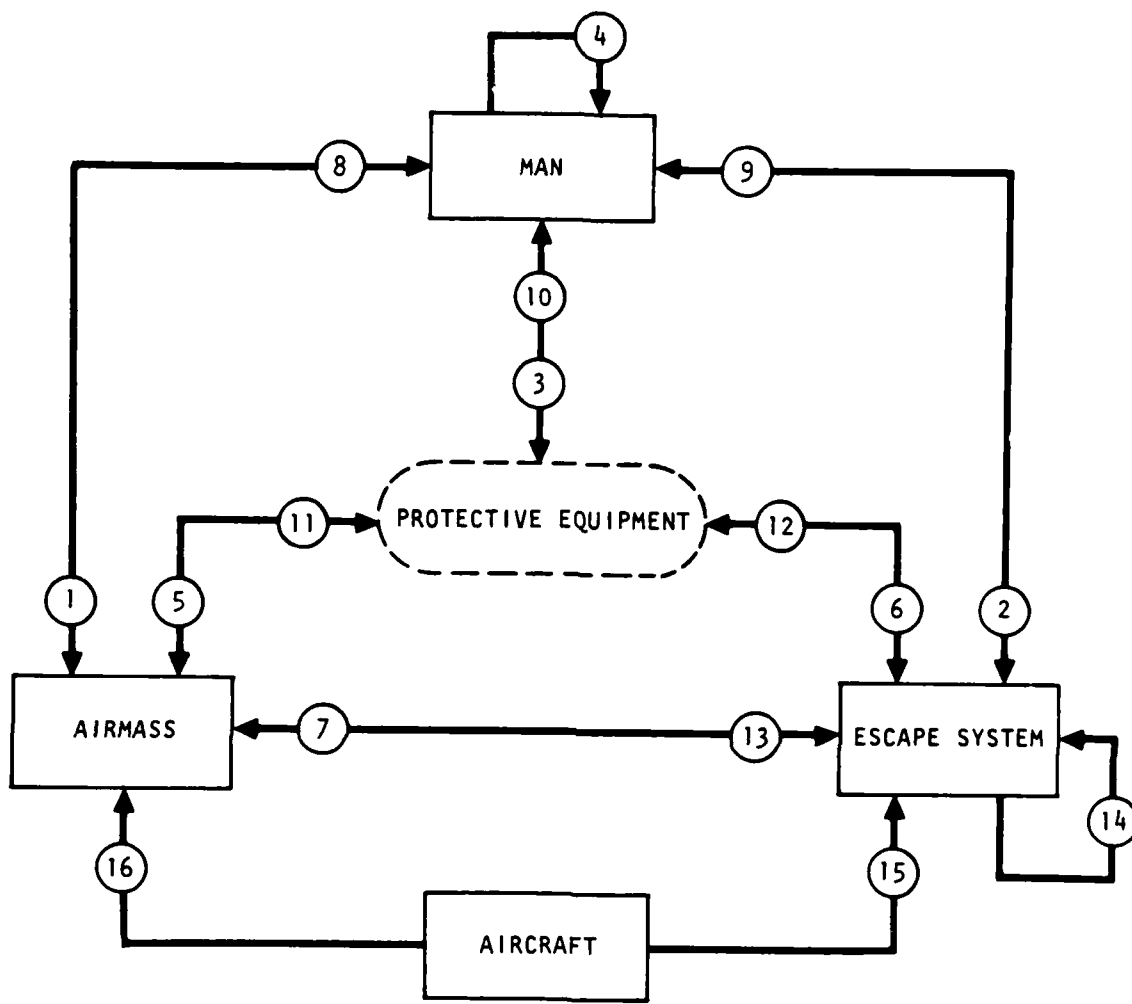

Figure 1. GENERALIZED ESCAPE ENERGY TRANSFER MODEL. Sixteen transfer paths that affect environmental stresses on the man during separation and deceleration. Note protective equipment, though not a major mass element, plays an important role in the energy transfer process.

### Airmass.

The airmass, though often conceived of as being in motion, is of course at rest before being disturbed by the aircraft and escape system. The dynamic response of the airmass to the passage of the aircraft and escape system results in aerodynamic forces on these objects and in the transfer of kinetic energy from them to the airmass. The kinetic energy imparted to the airmass by the aircraft can significantly affect the aerodynamic forces acting on the escape system during separation.

### Aircraft.

The aircraft as a mass element carries an enormous amount of kinetic energy at the speeds associated with a 1,600 psf escape environment. The movement of the aircraft through the airmass temporarily compresses the air surrounding the aircraft. In so doing, it also gives the airmass a transient radial velocity out from the flight path. This process causes a nonuniform distribution of airmass in the space surrounding the aircraft. It can also serve as a path for the transfer of kinetic energy from the aircraft to an escape system as it separates from the aircraft. Manipulation of control surfaces and aircraft attitude and engine thrust can all change the magnitude and direction of the aircraft velocity vector. Such changes also involve the transfer of kinetic energy to or from the escape system and man.

### Escape System.

The masses of both the escape system and man also carry large kinetic energies. The escape system must be considered a separate mass element from the man so that the energy transfers between escape system and man may be studied. At ejection, part of the escape system mass, the propellant, may be burned in a rocket motor to provide thrust. Such thrust can be used to push the escape system away from the aircraft and to prevent the conversion of translational kinetic energy to rotational energy; i.e., tumbling.

### Man.

The man is the most critical energy-carrying mass element involved in the escape process because his kinetic energy is the cause of most of the injuries associated with high psf escapes. The pertinent mass elements of the body are the arms, legs, head, torso, and critical subelements such as the spinal column. Balanced rapid removal of kinetic energy from these body segments and safe separation from the aircraft are the two main tasks of the escape system.

## Energy Transfer Paths

Sixteen energy transfer paths are represented in Figure 1. The transfers are represented as taking place between the major mass elements and through a fifth element called protective equipment. This may be personal equipment or special equipment which is attached to the main structure of the escape system but worn by or deployed over the man for escape protection. Each of the paths shown is a generalization so that more than one transfer process or event might be represented by a single path if the source and destination of the transfers are the same. The model and the following discussion of it are meant to apply generally to all escape system designs, unless otherwise noted.

### Energy Transfer Sequence.

An oversimplified but illustrative sequential description of the energy transfers in a high-Q ejection is as follows. At the moment of ejection initiation, the aircraft is imparting energy to the airmass (16)\* and escape system (15) through maneuvering loads. As ejection takes place, the escape system gains kinetic energy by thrusting away part of its own mass (14). Kinetic energy imparted to the airmass by the aircraft may be transferred to either the escape system (13), the protective equipment (11), or directly to the man (8). Kinetic energy imparted to the escape system may be transmitted directly to the man (9) or indirectly through the protective equipment (12 and 10). Kinetic energy in the man may be transferred either directly to the airmass (1), to the escape system (2), to the protective equipment (3), or from one of the man's constituent mass elements to another (4). The protective equipment can transfer the energy it receives directly to the airmass (5) or to the escape system (6). The escape system is usually designed to give up most of its energy to the airmass (7) because use of the airmass as the energy sink is effective in terms of weight savings. An alternative with both a weight penalty and offsetting benefits would be to use rocket propellant mass as an energy sink for the vertical component of the system's kinetic energy; i.e., its sink velocity. This is the strategy of a vertical steering thrust vector control system.

### Utility of a Descriptive Energy Transfer Model.

The preceding is a simple descriptive model of the complex energy transfer processes which occur during an ejection. The model is being used here because it facilitates the analysis of escape phenomena such as windblast into separate real-world processes. These processes and their interactions then serve as the basis for defining requirements for both escape system design and biomechanical research. A more detailed discussion of each of the energy transfer paths is presented in the following paragraphs.

\*See Figure 1 to identify the areas represented by the numbers listed in parentheses.

## Man to Airmass - Path 1.

The baseline escape system for this study, the ACES-II open ejection seat (refer to Douglas Aircraft Company (1978)), uses direct energy transfer from the man to the airmass to remove a significant part of the kinetic energy from the man and escape system. The process by which this takes place is illustrated in Figure 2. The following summarizes the transfer process for the torso. The movement of the torso compresses the airmass before it. The compression causes a rise in pressure which the torso feels. The increased pressure causes the airmass to flow to lower pressure areas. Air molecules behind the torso are caught up in the outward flowing airmass causing pressure behind the torso to drop. The high pressures on the front surface of the torso cause that surface to slow down so that it presses against the tissues behind it causing internal pressure. The integrated inertial response of all the mass elements which comprise the internal tissues results in an internal pressure gradient which drops front-to-back to the low pressure at the back surface. (See Figure 2.) The tissues, being pliable, flow in response to a pressure gradient. Without additional protection tissues would flow down the internal pressure gradient toward the sides of the torso generating potentially harmful shear forces. Additional protection in the form of a vest with inflated bladders around its sides and back might flatten the internal pressure gradient, so that tissue would be uniformly compressed by the inertia of the tissue and escape system masses behind it.

The transfer of energy from the head to the airmass is complicated by the helmet, oxygen mask, and headrest. Payne et al. (1975), found that large aerodynamic lift forces act to pull the helmet upward against the chin strap and possibly off of the head. This problem, which results from direct transfer of energy from helmet to airmass, might be reduced by an air stagnation canopy that would deploy over the helmet at ejection initiation (Figure 3). Another complication in transfer of energy from the head is presented by the inherent aerodynamic instability of the oxygen mask and hose. Kendall et al. (1979), reporting on tests of the effects of inadvertent canopy loss on the TF-15, indicated that the oxygen hose on an anthropomorphic dummy in the aft station blew over the dummy's shoulder at 450 KEAS. An oxygen hose over the shoulder at high-Q would probably put a large twisting moment on the helmet and the man's head. The forward projection of the oxygen mask is also a problem as it results in an imbalance of presented area as the helmet is turned to the side. Without changing existing equipment, some relief from this problem might be obtained if the oxygen hose were actively retained to the chest at initiation. A new windblast helmet with integral oxygen mask is a passive alternative, but would have to be much lighter weight than previously developed designs. Finally, the helmet covers the back of the head so that, while the pressure at the back of the helmet is expected to be low, the pressure at the back of the head may be much higher. Therefore, the helmet could receive a much larger net pressure force than the head. This would result in a large part of the head's kinetic energy being passed through the forehead pad and oxygen mask rather than directly to the airmass. The appropriateness of the oxygen mask design for applying such loads to the face should be reviewed.

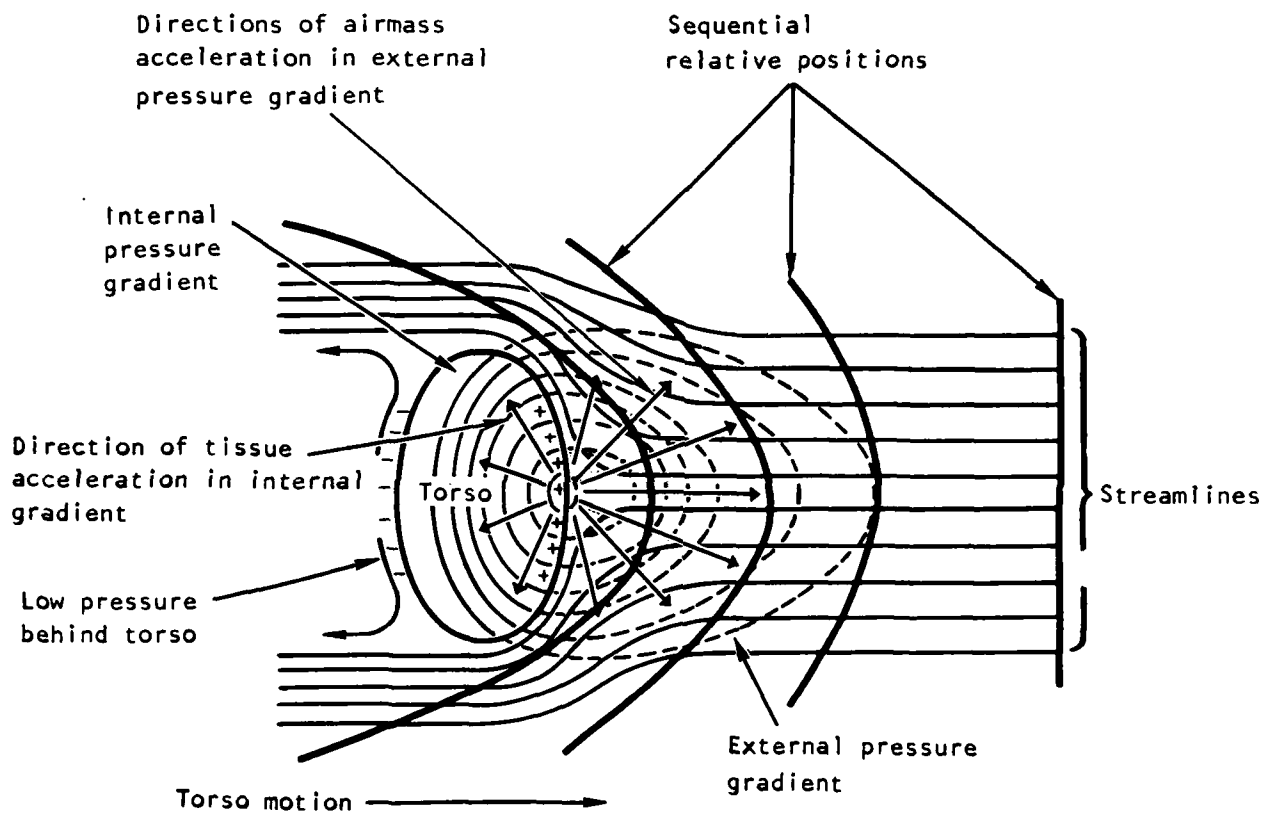

Figure 2. Conceptualized Interaction Between Man and Airmass

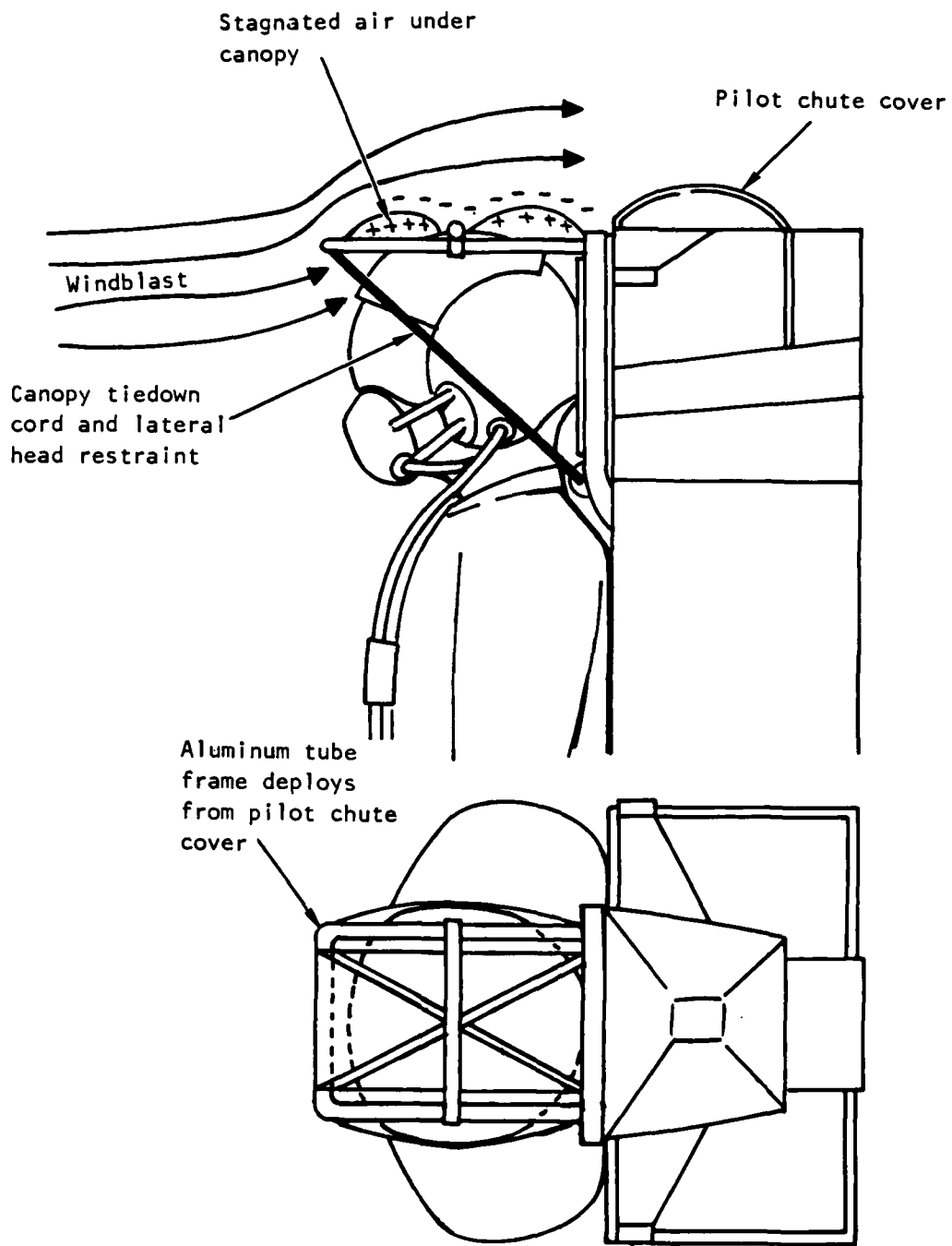

Figure 3. Stagnation Canopy for Helmet Retention During High-Speed Ejections

As the baseline seat travels through the airmass, the arms feel pressure from the flow of the airmass around the sides of the torso. Because the arms obstruct this flow, the total pressure on the front of the torso increases and this increases the rate of energy transfer from torso to airmass. However, the damming or stagnation of the airflow around the torso also increases the pressure felt by the arms. Payne et al. (1975) and Hawker et al. (1976) studied the magnitude of the pressure forces felt by the arms in a series of wind tunnel tests using human subjects at low Q-levels. More recently, Anthony (1979) extended these studies to higher Q-levels with an instrumented dummy in a model of the baseline escape system. These studies show that the lateral and upward acting pressure forces on the arms, which are not balanced by the inertial response of the arms to deceleration, cause forces at the hands which exceed the grip strength capabilities of most pilots at Q-levels as low as 800 psf. Loss of a hand grip results in much more rapid deceleration of the arms than the torso/seat mass, leading to flailing injuries. Cummings (1979 and 1980) and McDonald (1979) conducted design studies of arm-restraint concepts for baseline-type escape systems. A review of these studies showed that restraint designs exploit one or both of two distinct strategies for arm protection. One is to physically connect the lower end of the arm to the seat. This provides for a restraint force against upward outward pressure and, conversely, for the transfer of kinetic energy from the seat/torso mass to the arm. This strategy assumes that the arm will be exposed to a local airmass flow. The second strategy is to retract the arm out of direct exposure to an airmass flow or shield it or both. Figure 4 shows an example of an arm-restraint concept (new with this report) which employs the retract and protect strategy.

The legs, like the arms, dam or stagnate air which would otherwise flow over the seat. For the upper legs, the direction of action of aerodynamic forces depends on the attitude of the seat. When the seat is pitched back, high-pressure air is trapped under the knee while air is free to flow over the top of the thigh. This results in a large net lift force on the thigh. If the inertial response of the upper leg is not sufficient to cancel these lift forces, they will be carried to the knee joint ligaments. If the lower leg is prevented from moving in response to such loads, the result could be knee ligament sprain. When the seat is pitched down, air stagnates between the legs above the seat pan forcing them to spread apart. Fryer (1962) reported mild bilateral hip sprain injury to a human subject who was exposed to hydraulic ram pressure roughly equivalent to a 460 KEAS escape or 720 psf. The subject's knees were supported against lateral loads. Presumably, at Q-levels in the neighborhood of 1,600 psf, much more severe hip injuries would occur without special protection.

The lower legs present a large area to the airmass and would be exposed to a larger drag force than they are but for the presence of the front of the seat bucket directly behind them. The front of the seat bucket which is also moving through the airmass, diverts air to the space behind the lower legs so that low pressures do not develop there. This decreases the net aftward acting force on the lower legs. The baseline escape system provides lateral lower leg fences to limit lateral movement of the lower legs. The laterally trapped lower legs block the lateral flow of air around the seat bucket, resulting in higher pressure on the seat bucket and a greater rate of kinetic energy transfer

Pressure distributions  
without and with  
stagnation fences

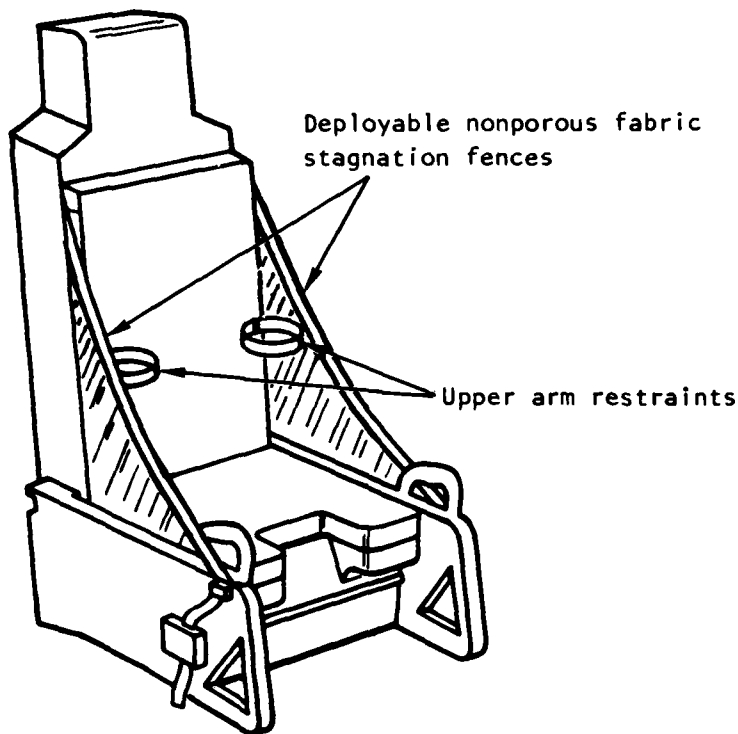
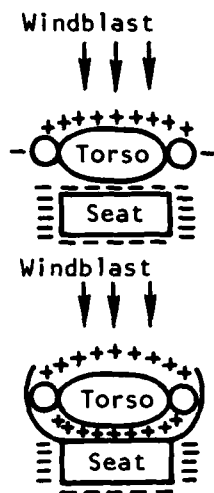

Advantages:

1. Reduces dislodgement forces on arms and legs
2. Protects abdominal organs from aerodynamic effects such as wind waves
3. Increases drag load on seat
4. May result in preloading of lap belt and shoulder harness and reduction in dynamic overshoot
5. May displace pressure center aft, improving aero stability
6. Low pilot encumbrance

NOTE: These are deployed after escape initiation and in conjunction with upper arm retraction to the side of the torso

Figure 4. Torso Airflow Stagnation Fence Arm Restraints

through the seat bucket front surface to the airmass. Most of the direct transfer of kinetic energy from the lower legs to the airmass takes place below the seat bucket, where low pressures can develop behind the legs. In particular, the feet are exposed to a disproportionately high drag load compared to the kinetic energy stored in their mass. The retention of the lower legs within the forward projections of the lateral leg fences is essential for the prevention of leg flail in the ACES-II baseline escape system. A critical point for such retention is drogue inflation, which not only puts a large decelerative load on the lower leg through the knee, but also causes the STAPAC rocket plume to swing forward toward the backside of the man's feet. This could potentially release the main retention force, drag, on the lower legs when it is most needed and, thereby, enable leg flail. A final comment on direct energy transfer from the lower legs to the airmass involves aerodynamic asymmetry of the booted foot. Such asymmetry could lead to torsion of the tibia, which could, in turn, excessively stress ligaments in the knee, as discussed by Grood et al. (1978).

#### Man to Escape System - Path 2.

For the ACES-II escape system, the drogue drag area is about 1.15 times the total seat-man drag area (7.5 vs. 6.5 sq ft). The seat-man drag area is about 1.25 times the drag on the man alone, Hawker et al. (1976:p.26). Therefore, the drogue drag is about 1.44 times the direct drag on the man. Since the drogue drag is created by the transfer of kinetic energy from both the seat and man masses, and the man's mass ranges from 40 to 55 percent of the ejected mass, the static drogue drag force due to energy transfer from the man ranges from 58 to 80 percent of the force due to direct energy transfer from the man to atmosphere. Dynamic features of drogue inflation and seat-man coupling can produce transitory forces more than double this underlying static drogue drag force on the man.

The shoulder/parachute harness and lap belt are the intended man to escape system energy transfer paths. However, the actual paths depend on the attitude of the escape system during the time the energy transfer takes place. For example, at high pitch angles, a large energy transfer from the man to the seat pan can occur.

Regarding the man to escape system energy transfers, some general rules may be stated:

- The airmass, discharged rocket propellant mass, and aircraft are the three possible local sinks for the man's kinetic energy. The combinations and sequence of use of these energy sinks determine which man/escape system interfaces will be involved in kinetic energy transfers.
- If the airmass is to be the principle local sink, then the man should be positioned with his frontal plane perpendicular to the flight path (face to the wind), giving maximum tolerance to drag deceleration.

- If the discharged rocket propellant is to be a kinetic energy sink, then the man should be positioned with his frontal plane perpendicular to and facing in the direction of the sum of the thrust and drag vectors. Also, in low altitude high sink rate ejections, the thrust vector direction should be controlled to maximize the vertical component of the thrust-drag resultant. These rules provide for maximum performance in maneuvering aircraft and ground impact avoidance.
- The aircraft can be a local sink, as when the escape system is separating from a highly loaded aircraft. In this case, the man should be positioned with his frontal plane parallel to the long axis of the aircraft, giving maximum tolerance to aircraft separation thrusting.

When the airmass is to be the energy sink, the design goal has been to slow the escape system and man as quickly as possible to obtain the best low-altitude performance. This means a drag load as high as the man can tolerate, which in turn means positioning his frontal plane perpendicular to the flight path. If a vertical steering thrust vector control system (VS/TVC) is developed, it may be possible to selectively transfer the man's downward kinetic energy to the ejected rocket propellant mass. Such a system could reduce the need for maximum tolerable deceleration in many shallow dive/moderate sink-rate ejection cases. However, the extent of this benefit is proportional to the impulse of the rocket (with the implication of more weight) and the ability of the VS/TVC to maintain the escape system attitude stable at high angles of attack.

For a baseline escape to separate from a highly +G<sub>z</sub> loaded aircraft, the energy transfer through the seat pan must exceed man's tolerance. Three alternatives to the baseline system are available:

- Position the man's torso to be perpendicular to separation thrusting
- Transfer energy from the man through paths other than the seat pan
- Abandon vertical thrusting to achieve aircraft separation; e.g., separable forebody

The following three subsections are discussions of particular problems which involve man-to-escape-system energy transfers. They illustrate the variety of proposed design approaches and the need for more integrated design strategies.

#### Seat Pan

Transfer of the man's kinetic energy via the seat pan to the airmass occurs when the seat pitches back during separation. Freeman et al. (1980), in their six-degrees-of-freedom (6-DOF) computer model study of aerodynamic interactions between an ejecting seat and the flow field surrounding a B-1 bomber aircraft, found that the flow field induced a large pitch moment on the seat at dynamic pressures in the neighborhood of 1,200 psf. The moment is easily large enough to overwhelm the pitch trim rocket and to pitch the seat back increasing the

drag component in the man's spine. This occurs before the drogue chute can apply an opposing pitch-down moment. With the seat in a pitched back attitude, the 6-DOF simulations show the combination of drag and rocket thrust along the man's spine exceeds the dynamic response index (DRI) criterion before drogue chute inflation (90-percent probability of spinal injury). Inflation of the baseline 5-foot drogue makes the spinal injury potential even worse. Alternative approaches for solving this problem of excessive forces through the seat pan include:

- Better pitch attitude control, such as with TVC or aerodynamic control surfaces (Refer to Beale (1975) and Payne (1974))
- Support of the torso mass from the headrest area to offset loading of the spinal column (discussed later)

#### Integrated Harness and Lap Belt

In the baseline escape system, the transfer of energy from the man to the harness and lap belt normally begins with drogue inflation. The inflation event causes a large shock load to be applied to the seat, which results in a rapid decrease in velocity of the escape system. The ensuing separation between escape system and man is then arrested by the harness and lap belt. Limb restraint design problems associated with this event were reported by Cummings (1980). For a baseline seat-drogue system with a total drag area of 14 sq ft (6.5 for the seat and 7.5 for the drogue) at a Q-level of 850 psf, the total static drag load is 11,900 lbs. Dividing by 320 lbs for the seat-man mass (5th percentile man), the static G-load is 37 G. This compares with -Gx limits of 35 and 20 G for onsets greater and less than 30 milliseconds, respectively. Dynamic G-loads are much higher. The shoulder retraction reel straps are attached to the parachute risers, and the risers attach over the shoulders to the integrated restraint harness. The load bearing straps of the harness continue down the chest over the hips and under the buttocks to form a sling for deceleration and decent under the main parachute. The survival kit attaches to these load bearing straps above the hips. Although the harness could be adjusted through its attachments to the survival kit to provide snug upper torso restraint after the shoulders are retracted, the pilots choose not to make these adjustments because they interfere with the torso mobility required for external vision during air-to-air combat. A similar problem holds for the lap belt. Therefore, there is an artificial looseness in the harness and lap belt on the baseline system. This looseness in the coupling between seat and man invites dynamic amplification of the drogue shock forces as discussed by Payne (1965). Many alternative solutions to this problem have been proposed, including:

- A retractable chest strap, McDonald (1979)
- An inflatable vest worn between the chest and harness, Schwartz (1979)
- Various drogue force modulation techniques, Guarrancino (1976:p.93)

- An upper torso restraint vest worn over the harness and retracted to the seat as proposed in this report (Figure 5)
- Automatic lap belt tighteners

The ACES-II baseline escape system is aerodynamically unstable about the yaw axis. As a consequence, small yaw angles upon entry into the airmass will result in large yaw angles before drogue inflation. This causes side loads on the man from direct energy transfer to the airmass. Man's tolerance to direct aerodynamic side loading is not well-defined but should be greater than his tolerance to side loads applied through just the lap belt and shoulder harness. This is because the dynamic pressure works on a larger area. If the seat is yawed at the time of drogue inflation, a large amount of kinetic energy will be transferred from the man to the seat through sideward forces applied to the shoulder harness and lap belt. The translational coupling between man and escape system is even worse for lateral motion than fore-aft motion; i.e. more loose play. Therefore, the potential for dynamic amplification of lateral forces is also worse. Payne (1965:p.78) recommended that restraints allow no more than 2 inches lateral displacement, which the baseline system exceeds by more than a factor of two. Some concepts for improving the lateral coupling between man and seat include:

- A circumferential lap belt arrangement (Figure 6)
- An upper torso restraint garment (Figure 5), also recommended by Swanson (1978) for further study
- Padded extensions of the seat sides and seat back to provide structural support to the shoulders and hips as proposed by McDonald (1979) and as is being implemented on the AFTI/F-16 (refer to General Dynamics (1980:p.A-157))

Concepts for obtaining yaw stability until drogue inflation include:

- Thrust vector control, Beale (1975) and Tauby et al. (1979)
- In-plane stabilizers as proposed by Payne (1974) for static yaw stability
- Paired yaw moment drogues on controller braked wire reels (Figure 7)

Hawker et al. (1976) studied the relative distribution of drag force between the man and the baseline escape system. Their findings indicate that prior to drogue inflation, the man's torso feels a large net pressure force due to high ram pressure on its front and low pressure at its back. The seat, however, has a relatively small net-pressure force acting on the front of the backrest because the man's torso shields it. If airflow stagnation fences (Figure 4) were deployed between the seat bucket and seat back on either side of the torso, then high pressure stagnated air would pass behind the man and act on seat back as a large net pressure force. The net ram pressure force on the man would be reduced because the high pressure at the front of the torso would be matched by high pressure at the back. The net force on the seat back would

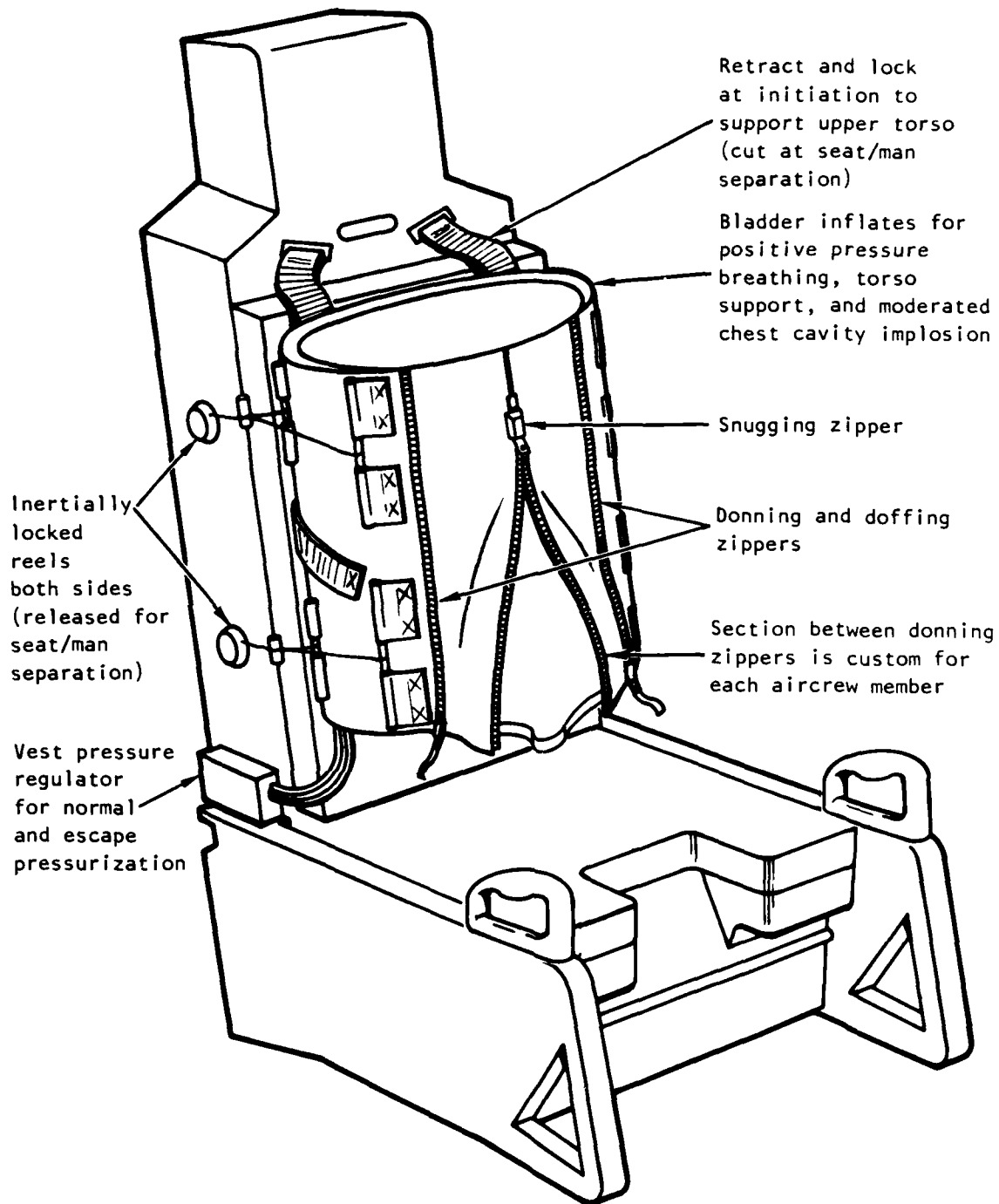

NOTE: This concept integrates upper torso support for ejection  $+G_z$  and  $-G_x$  with direct-side-force support, positive pressure breathing, and explosive overpressure protection.

Figure 5. Upper Torso Support Restraint Garment

Features:

- Two attachments and two adjustments
- Automatic adjustment for hip breadth gives good  $\pm G_Y$  restraint:
- Compatible with ACES-II belt release
- Two crotch straps for comfort and safety in  $+G_Z, -G_X$  support

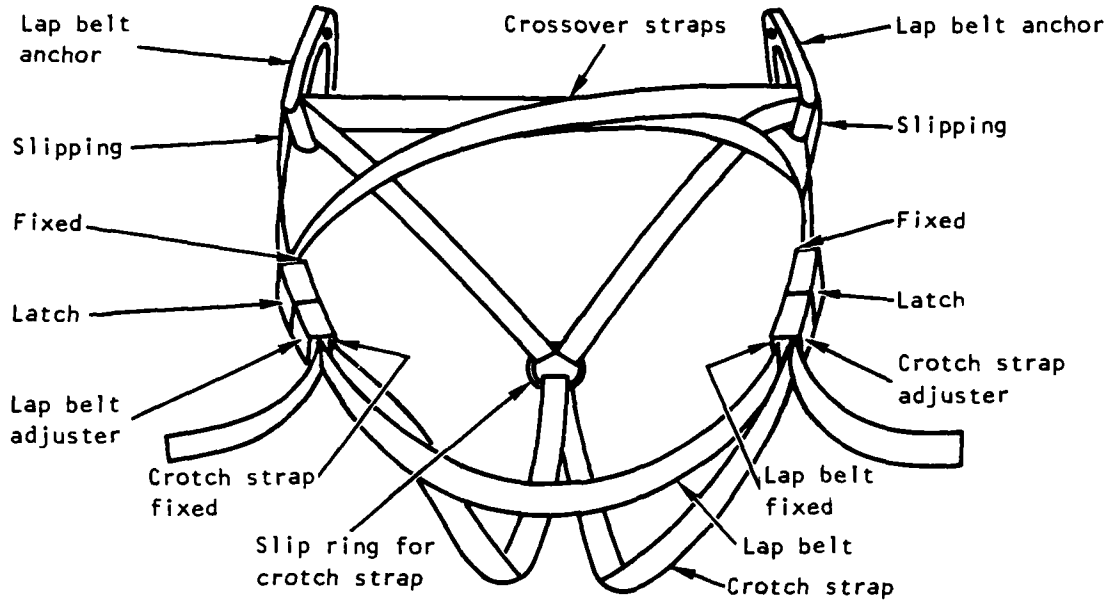

Figure 6. Multiaxial Pelvis Restraint

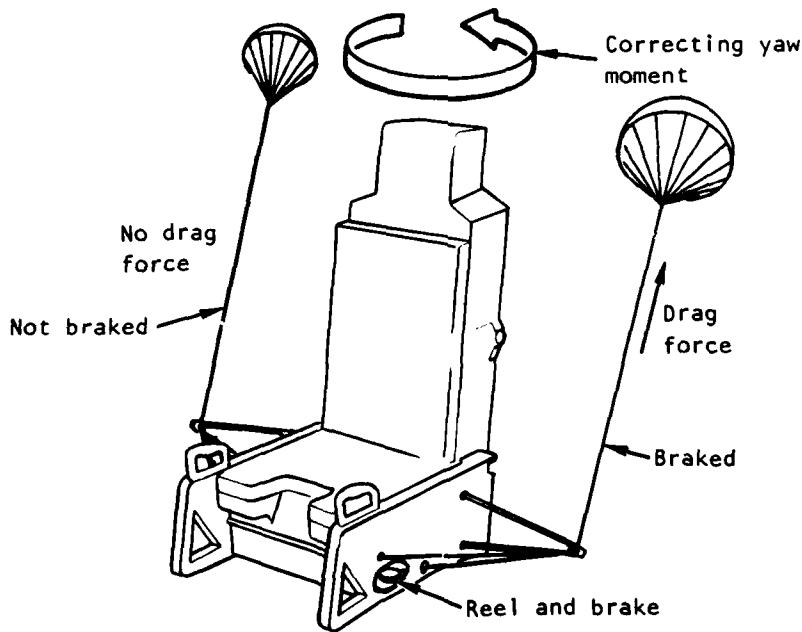

Figure 7. Paired Yaw Moment Drogues on Attitude Controller Braked Wire Reels

increase loss of seat energy to the airmass (transfer path 7, in Figure 1). This would, in turn, result in increased forces on the lap belt and shoulder harness. Potential benefits from this arrangement include:

- Reduced dynamic amplification of drogue inflation shock loads through preloading of the lap belt and shoulder harness
- Provision of stagnated flow regions in which the arms can be held by simple upper arm collars, thus precluding upper and lower arm flail
- Increase in pressure on the sides and tops of the thighs, reducing the excessive net forces on the upper legs as reported by Fryer (1962)
- Improved seat stability due to an aftward displacement of the pressure center relative to the CG

A potential hazard associated with the torso stagnation fence concept is that of chest cavity implosion as described by White et al. (1971) in the context of blast shock wave overpressures. This phenomenon occurs as a result of rapidly rising pressure surrounding the chest as might be caused by the stagnation fences upon entry into the airmass. The momentum the chest walls gain as they collapse into the lung space carries them past the pressure equilibrium point to create a large overpressure in the lungs. The overpressure then pushes the rib cage back out to begin another cycle. The resulting oscillations may alternately cause hemorrhage into the lung space and then the introduction of air into the circulatory system. A strategy to reduce the amount of implosion that occurs is to inflate a torso vest worn by the occupant to a high pressure before entering the airmass while simultaneously applying a high pressure to the lungs through the oxygen mask. The result will be a slower controlled collapse of the chest wall with less overshoot and with prepressurization of the lung space. Therefore, the chest-wall/lung system will be relatively stiff as the ram pressure rapidly builds around the torso at airmass entry.

#### Reclined Seats

The design tactic of increasing the back angle of the seat before entering the airmass, proposed by Tauby et al. (1979) for the supine seat, and by Swanson (1978) for the curved rail seat, reduces the direct transfer of energy from man to the airmass by shielding, and reduces the indirect transfer rate by drag area reduction. (See Figure 8.) The supine seat concept has a large included angle between the back support and seat pan (150 degrees), so that the pelvis rests on the posterior superior iliac spines and sacrum rather than the ischial tuberosities as with the baseline seat. This large angle precludes hard contact between the seat pan and ischial tuberosities. The supine seat concept normally holds the man's torso parallel to the flight path during deceleration, so the available pathways for transferring the man's kinetic energy to the escape system would be through the integrated restraint harness, the legs, and/or some rigid platform actively deployed from and attached to the seat pan to provide a reaction surface for the pelvis. The integrated harness would slow the body similar to the way it does under the main parachute. Potential problem areas are the need to preload the harness, the load path over

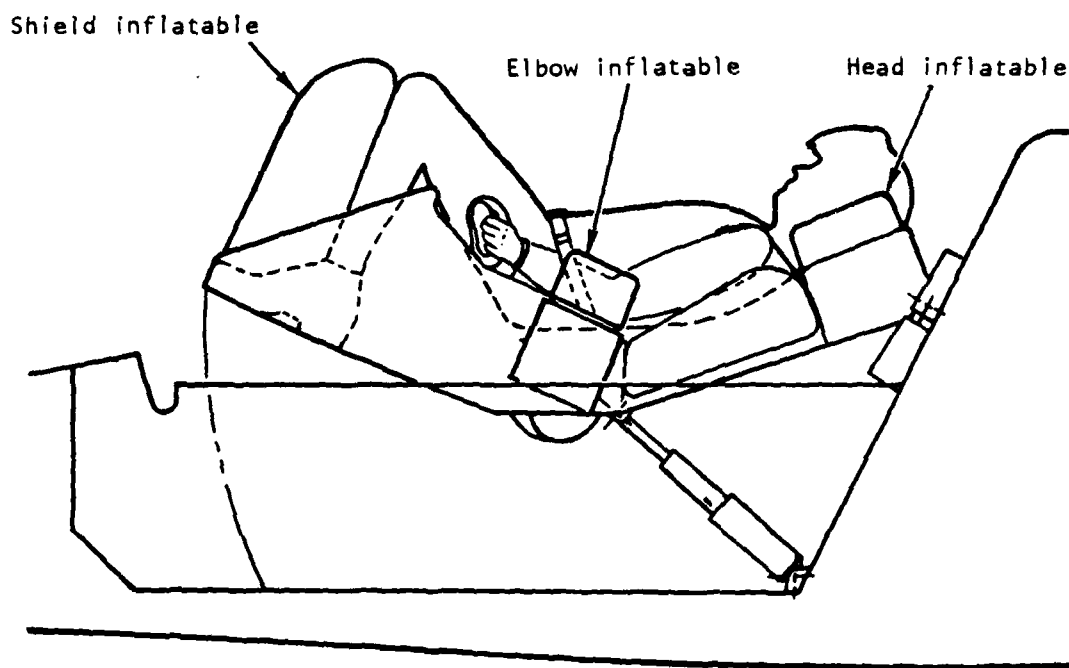
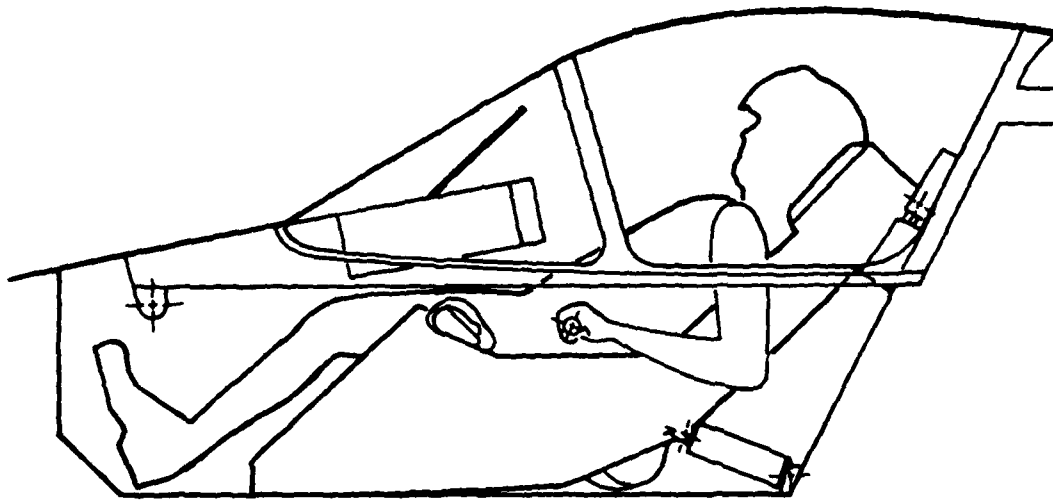

Figure 8. REQLINED ESCAPE SYSTEM (Reference Tauby et al. (1979))

the shoulders, and more severe onsets for 1,600 psf drag and drogue inflation. The inflatable upper torso support vest concept described earlier would serve here for improved general restraint and as an additional transfer path to the seat. As for the legs, the supine seat concept may require the lower legs to carry some proportion of the drag load on the inflatable shield which is positioned in front of them. This passed-on drag load creates a backward moment on the lower legs about the feet which are trapped under the shield. This moment is resisted primarily by the posterior cruxiate ligament in the knee joint. A forward shift of the torso in response to seat deceleration would push the upper leg forward and upward into the knee joint further stressing the ligament. To prevent knee injury, most of the energy transfer should be accomplished through the torso restraints or a reaction surface deployed from the seat pan to support the pelvis. The load which the deflector shield applies to the lower legs should not approach the load-bearing capacity of the posterior cruxiate ligament. A flip-up reaction surface on the seat pan would provide the best control of dynamic response and loading of the knee joints.

#### Man to Protective Equipment - Path 3.

Some energy transfers from the man to his protective equipment have already been mentioned:

- From the head to the helmet
- From the torso to harness, lap belt, or a restraint vest
- From arms and legs to limb restraints, or a deflector shield

As a general rule, such transfers become more important in systems in which the man is shielded from direct energy transfer to the windblast. In those systems the protective equipment usually transfers a much larger proportion of the man's kinetic energy. Without the damping effect of the air mass, the man's dynamic responses to deceleration will be more severe, requiring increased restraint surface areas and automatic snugging. Where the head is shielded, the helmet mass could actually pass kinetic energy to the head, possibly creating a requirement for an energy attenuation device such as an inflatable neck collar.

#### Man to Man - Path 4.

The design of a safe escape system ultimately reduces to a system of problems regarding the control of internal transfers of energy between the mass elements of the man. For the baseline-type escape system, the most problematic internal energy transfers have been those associated with the following events:

- High-Q drogue opening shock
- Arm, leg, and head flailing

- Unstable seat/man separations
- Prolonged high deceleration from high speeds

Additional internal transfer problems associated with the 1,600 psf windblast and high-maneuver load escape environments include those associated with combined aircraft separation forces and drag loads, and blood flow and hyperpressure in response to deceleration and possibly unequal pressure distribution over the body.

#### Arm, Leg, and Head Flailing

Some energy transfer problems regarding the arms, legs, and head have already been mentioned; the powerful outward forces on the arms due to airflow around the torso, the critical restraint period for the lower legs, and the coupling between the head and helmet under aerodynamic loading in a deceleration field. Active (retracting) restraint of the arms is required for reliable arm restraints in command ejection situations. But designs for active arm restraints on open ejection seats have proven difficult to develop because of conflicting requirements. (Refer to Cummings et al. (1979 and 1980).) Passive arm restraint designs are attractive because they need not be attached to or worn by the aircrews. However, passive designs with a convincing ability to rapidly and reliably deploy for good support in the presence of high-Q windblast have also proven difficult to develop. (Refer to Woodward et al. (1980) and McDonald (1979).) The open-seat arm restraint design proposed in this study is a hybrid of active and passive approaches. An elastic restraint collar is positioned on the arm above the elbow to minimize encumbrance of the aircrew. This collar retracts the upper arm to the seat back at ejection initiation. This action clears a path for deployment of airflow stagnation fences on either side of the torso. The unrestrained lower arms are held in the partially stagnated air trapped by these fences and, therefore, should be protected from the aero forces which normally cause arm flail.

There are special internal energy transfer problems associated with protection of the legs. One involving kinetic energy transfer from the torso through the knee joint on the reclined seat has been discussed. Cummings (1980) described another which involves retention of the lower leg by a collar just below the knee. At drogue inflation when the seat suddenly decelerates with respect to the body, the collar rapidly removes kinetic energy from the top of the lower leg. Meanwhile, both the bottom of the lower leg and the thigh continue their forward motion until stopped by tension in the ligaments of the knee joint. There is a tremendous mechanical disadvantage for the ligaments of the knee in this situation. This internal energy transfer consideration generates a general rule that lower leg restraint forces should not be applied exclusively near the knee and should accommodate extremely rapid aft deceleration of the seat relative to the upper and lower legs.

Flailing of the head may occur during separation from the aircraft for any or all the following reasons:

- Head and neck may be bent forward during catapult stroke, then be blown back by high-Q, coupled with rocket thrust, then bent forward again by drogue inflation sock load applied through the shoulder harness
- Maximum-Q passing through the compressed air layers in the aircraft flow field
- Adverse seat attitude before correction by the control system
- Oxygen hose dragged over shoulder torques helmet
- Helmet and mask aerodynamic asymmetry generates twisting moments
- Helmet/headrest aerodynamic interaction generates separation forces
- Low pressure on top and sides of helmet causes lifting of helmet from head

As with arm and leg flailing the potential for injury from head flailing derives not so much from the displacement as from the arresting of relative motion between head and torso. Such arresting requires an energy transfer through the weak internal structures of the neck. Solutions for head flail already proposed include retracting the oxygen hose to the front of the chest, installing a stagnation canopy over the head, and using an inflatable neck collar. Other concepts include a new lightweight windblast helmet with better aerodynamic stability and lateral restraints integrated with a helmet canopy (see Figure 3). Head flail is also a problem in reclined and encapsulated seats, where the removal of the helmet-to-airmass energy transfer path means that the neck serves as the main transfer path to the torso for the kinetic energies of the head and helmet.

#### Energy Transfer in the Torso

The DRI and the acceleration radical (AR) defined in MIL-STD-9479 set the acceleration threshold for spinal injury for the Air Force flying population. These criteria are associated with a standard support/restraint configuration consisting of

- Shoulder harness
- Lap belt
- Seat with a 96-degree included angle between pan and backrest
- Less than 5-degree angle between backrest and catapult thrustline

The DRI criterion of 18 expresses the spine injury threshold in terms of acceleration along the spinal axis, and the multi-axis AR criterion expresses the reduction of the safe DRI level due to flexing of the spinal column in response to accelerations perpendicular to the spinal axis. The strategy used

- Head and neck may be bent forward during catapult stroke, then be blown back by high-Q, coupled with rocket thrust, then bent forward again by drogue inflation sock load applied through the shoulder harness
- Maximum-Q passing through the compressed air layers in the aircraft flow field
- Adverse seat attitude before correction by the control system
- Oxygen hose dragged over shoulder torques helmet
- Helmet and mask aerodynamic asymmetry generates twisting moments
- Helmet/headrest aerodynamic interaction generates separation forces
- Low pressure on top and sides of helmet causes lifting of helmet from head

As with arm and leg flailing the potential for injury from head flailing derives not so much from the displacement as from the arresting of relative motion between head and torso. Such arresting requires an energy transfer through the weak internal structures of the neck. Solutions for head flail already proposed include retracting the oxygen hose to the front of the chest, installing a stagnation canopy over the head, and using an inflatable neck collar. Other concepts include a new lightweight windblast helmet with better aerodynamic stability and lateral restraints integrated with a helmet canopy (see Figure 3). Head flail is also a problem in reclined and encapsulated seats, where the removal of the helmet-to-airmass energy transfer path means that the neck serves as the main transfer path to the torso for the kinetic energies of the head and helmet.

#### Energy Transfer in the Torso

The DRI and the acceleration radical (AR) defined in MIL-STD-9479 set the acceleration threshold for spinal injury for the Air Force flying population. These criteria are associated with a standard support/restraint configuration consisting of

- Shoulder harness
- Lap belt
- Seat with a 96-degree included angle between pan and backrest
- Less than 5-degree angle between backrest and catapult thrustline

The DRI criterion of 18 expresses the spine injury threshold in terms of acceleration along the spinal axis, and the multiaxis AR criterion expresses the reduction of the safe DRI level due to flexing of the spinal column in response to accelerations perpendicular to the spinal axis. The strategy used

by the baseline escape system to protect the spine is to hold the frontal plane nearly perpendicular to the flight path by means of a pitch trim rocket. This is intended to minimize drag-induced spinal compression forces by aligning the longitudinal body axis with the drag forces. This, in turn, permits maximizing the drag forces, which provides for the maximum safe escape envelope consistent with the tolerance of the spine. A problem with this strategy is that the requirement to hold the body frontal plane in alignment with the flight path is not compatible with escape from unstable or maneuvering aircraft. Under these conditions, the aircraft attitude will initially be imposed on the escape system by the pitch trim rocket. Therefore, some forces will be applied to the body in the lateral or spinal axes. The drag forces at 1,220 psf correspond to the AR injury threshold with no lateral or spinal loads. At 1,600 psf in an upright seat, either the baseline body support/restraint must be modified to increase the injury threshold or the drag accelerations must be reduced.

Strategies for reducing drag decelerations include increasing system weight, adding drag countering thrust, delaying drogue deployment or reducing drag area. All of these options would increase the distance covered during seat deceleration. This effect itself would increase with the design to range of adverse seat attitudes for which safe escape would be provided for at 1,600 psf.

In contrast improving the body support/restraint would involve shifting part of the torso inertial load from the seat pan to an upper torso harness and supporting the torso against flexing in response to  $-G_x$  and  $-G_y$  loading. These support/restraint modifications would directly apply forces to the rib cage and the abdomen and, therefore, should change the internal energy transfer pathways toward increased tolerance to both separation and deceleration forces. This should permit reduction of the distance covered during seat deceleration relative to baseline support/restraints.

Direct application of vertical separation force to the upper torso through protective equipment should have the effect of increasing the natural frequency of the supported spine (refer to Olsen (1971)) and, therefore, the DRI threshold for injury. Direct application of longitudinal and lateral restraint forces to the rib cage should reduce flexing of the spine and, therefore, reduce the amount of spinal injury threshold reduction implicit in the AR criterion.

Solutions involving increased weight, increased drag-countering thrust, or delaying drogue deployment, when not accompanied by some means of deflecting the air mass away from the body, could be faced with the problem of deceleration squeeze as observed by Stapp et al. (1956) and identified by Fryer (1962). The torso is squeezed between the ram pressure and the inertia load of the seat and thrust of a rocket. This could greatly increase blood pressure in the torso. Hemorrhage into the lung space could become a problem. If a countering pressure is not applied to the head, blood may flow to the head under high pressure. When coupled with inertial hydrostatic spinal fluid flow effects operating in the opposite direction, the squeeze effect may be important, especially if the ejectee is wearing a full face windblast protection helmet.

#### Protective Equipment to Airmass - Path 5.

The following protective equipment may channel kinetic energy from the man to airmass at rates in the neighborhood of injury threshold.

- Helmet/face mask
- Torso restraint garment
- Stagnation fences
- Deflection shields

The helmet receives energy from the head at the forehead pad and oxygen mask seal and passes the energy to the airmass through the visor and mask shell, deflecting airflow around the sensitive organs of the face. In the baseline system, the aerodynamic instability of the helmet/oxygen mask is a problem at 1,220 psf. For an upright seat configuration at 1,600 psf, the helmet lift must be nullified by a stagnation canopy. The oxygen mask must be redesigned for less side presented area and for oxygen supply through the helmet to remove the problem of oxygen hose flagging.

The proposed torso restraint garment, if installed on a conventional upright seat, would stand between the airmass and torso. The low pressure otherwise felt at the sides of the torso is compensated by inflation of bladders inside the torso garment. This helps establish a more uniform pressure distribution through the tissues in the torso, reducing phenomena like wind-induced waves on the abdomen (tissue flagging).

Stagnation fences, such as in Figure 4, create a pool of high-pressure air between them which moves with the escape system through the airmass. Energy is transferred from the escape system through this pocket of stagnated air to the airmass.

A deflection shield, which is deployed between the man and the airmass (Figure 8), transfers energy from the escape system to the high-pressure zone which builds in front of the shield. The high-pressure zone causes the airmass to flow outward around the man.

#### Protective Equipment to Escape System - Path 6.

The proposed torso restraint garment (Figure 5) and lower leg restraints (Figure 9) are examples of paths where kinetic energy is passed from the man through the protective equipment to the escape system. On a baseline seat, only the shoulder harness, lap belt, and seat pan transfer kinetic energy from the man to the seat. The torso garment offers the advantages of a much larger surface area, better lateral support, and control of internal pressure gradients. The torso garment should also produce a much improved coupling between man and seat in X, Y, Z translation and in yaw, roll, and pitch. The largest energy transfer rate occurs at drogue inflation. The severity depends on the escape system attitude at the time and, therefore, on the processes

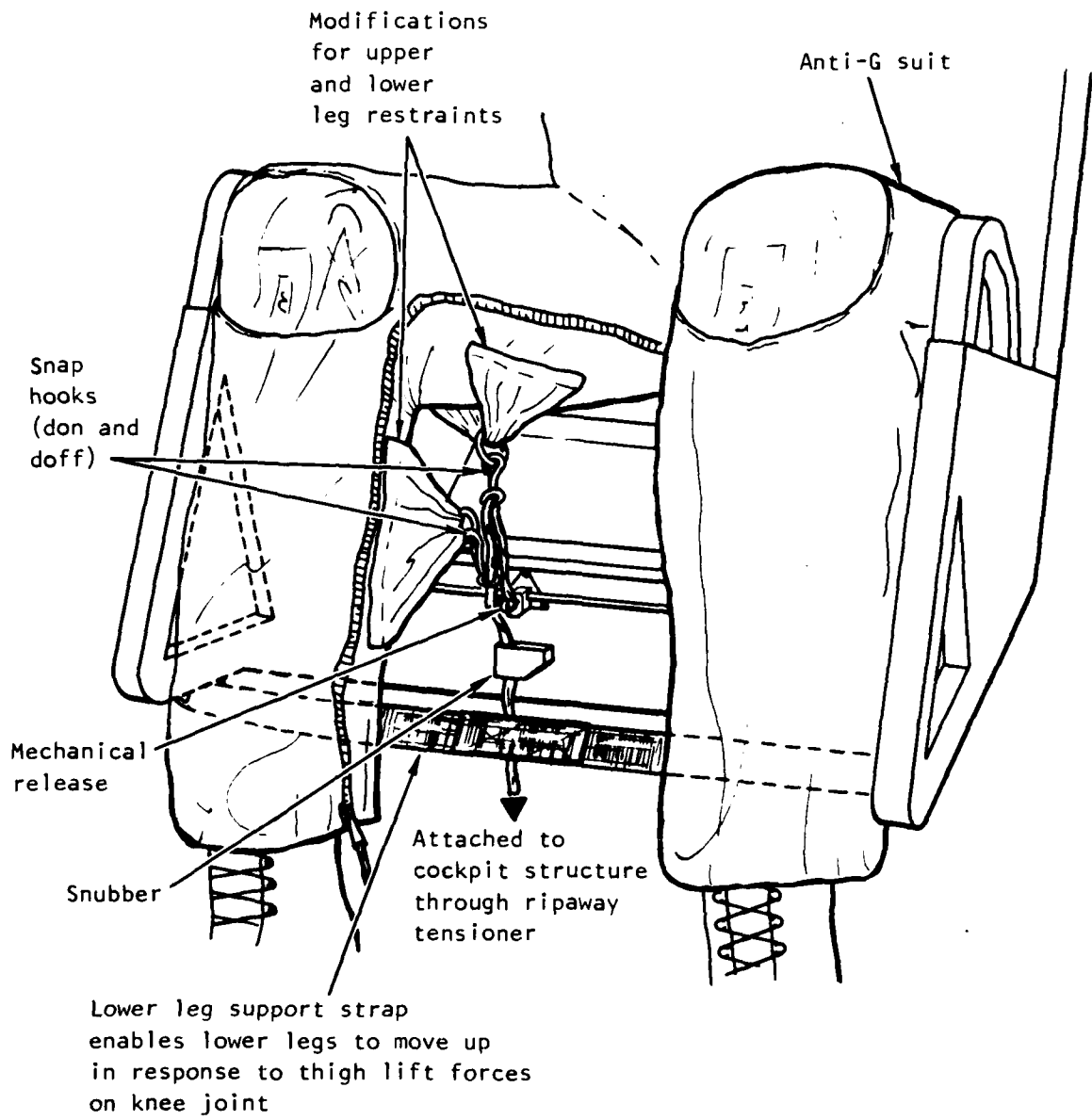

Figure 9. Leg Restraint Integrated With Anti-G Suit

which control attitude. Insofar as stiffer seat/man coupling will contribute to near-zero seat attitude at drogue inflation, the torso garment might further improve tolerance to the large energy transfers. For the baseline system, the transfer of kinetic energy from the lower leg to a below the knee restraint collar is discussed under transfer path 4. As the location of a restraint on the lower leg is important, so is the location of the retracting cord reaction point on the seat. If the restraint load is brought to a point on the seat close to the knee, as the leg rotates forward a force will develop on the restraint in a direction up the lower leg. This force, in turn, may cause the restraint to slip up the leg reducing its effectiveness as an anti-flail restraint.

#### Escape System to Airmass - Path 7.

The transfer of energy to the airmass occurs by direct pressure on the seat structure and by deployment of drogue parachutes. On the baseline escape system, direct transfer from the seat to the airmass is relatively small because the man's body deflects most of the airmass away from the seat, Hawker et al. (1976:p.26). Therefore, when the drogue inflates, the force relationship between man and seat reverses suddenly. Such sudden reversals are dangerous at high-Q levels because of the large magnitude of the drogue-opening shock and because of amplification of the drogue shock due to displacement of the seat from the man before mechanical coupling is reestablished through the harness and lap belt. As mentioned in the discussion of transfer path 2, torso stagnation fences (Figure 4) would cause the space between the torso and backrest to be pressurized to full ram pressure. This would greatly increase the rate of energy transfer from escape system to airmass.

The drogue on the baseline seat is sized to correspond to the man's maximum -G<sub>x</sub> tolerance at 1,220 psf. For 1,600 psf deployment, the drogue must either be made smaller, which would lengthen the deceleration distance, or designed with a modulation feature which ideally tends to keep the drag force at a high but safe constant level as Q decreases. The inflatable stabilization-deceleration system proposed by McDonald (1979:p.25) approaches this ideal modulation. Two-staged drogue systems were studied by Guarracino et al. (1976:pp.32 and 93).

#### Airmass to Man - Path 8.

Recent studies by Freeman et al. (1980) and Anthony (1979) among others have shown that aircraft interaction with the airmass results in significant energy being stored in the flow field around the aircraft. Freeman found that the aerodynamic stability properties of the ACES-II seat are significantly different in the flow field of the B-1 bomber than in the free stream at 600 KEAS. Anthony is studying the effect of the flow field on aerodynamic loading of the limbs and head. Indications are that the difference between free-stream and flow field effects is large at 1,220 psf and will be much larger at 1,600 psf. From the energy transfer perspective, the difference in effects is due to energy first stored in the airmass by interaction with the aircraft forebody and then transferred to the man and escape system.

### Escape System to Man - Path 9.

The escape system applies propulsion forces to the man which act to accelerate or counteract deceleration of the body. The kinetic energy transferred from the escape system to the man can originate from any of the four mass elements through the following transfer paths:

- Aircraft (paths 15 and 9, and/or 15, 12, and 10, and/or 16, 13, and 9)
- Airmass (paths 8, and/or 11 and 10, and/or 13, 12, and 10, and/or 13 and 9)
- Escape system (paths 14 and 9, and/or 14, 12, and 10, and/or)
- Man (paths 2, 12, and 10)

Aircraft accelerations can cause kinetic energy to be passed to the man through the escape system body support/restraint surfaces. Kinetic energy in the flow field can act on the seat to increase the separation acceleration, Freeman (1980). The catapult and/or rocket will generate forces on the escape system which are then transferred through support restraint surfaces to the body. Finally, the energy initially stored in the torso mass can be transferred to the seat through the harness and lap belt and then back to the body through arm, leg, and head support/restraint surfaces.

### Protective Equipment to Man - Path 10.

Protective equipment in the form of special body supports can help control the transfer of energy to the man or between his body segments during separation thrusting, windblast deceleration and drogue shock. It should be possible to design an upper torso support vest which could be retracted to lift the rib cage away from the seat pan during catapult stroke. Such a support would carry part of the upper body inertial load reducing the DRI for the typical acceleration profile. The vest should also reduce drag and drogue inflation loads in the lower spine. Protective equipment can also transfer energy to the head and limb segments when their drag/mass ratios exceed that of the seat and torso. Examples of protective equipment designed to transfer energy to the man are the lateral head restraints in Figure 3, the support vest in Figure 5 and the lower leg support strap in Figure 9.

### Airmass to Protective Equipment - Path 11.

Protective equipment must be designed to maintain tolerable forces on the man during passage through the aircraft flow field.

### Escape System to Protective Equipment - Path 12.

In situations where direct transfer of energy from the escape system to the man is limited by biomechanical considerations, the transfer must take place

through special protective equipment which circumvents the biomechanical limitations; e.g., an upper torso garment which supports upper torso  $+G_z$  to circumvent DRI limitations on Z-axis accelerations or arm restraints which apply forces near the end of the arm to counteract arm deceleration in windblast. The pattern of stress developed inside the body due to the transfer of energy from protective equipment is largely dependent on the geometry of the escape system to protective equipment energy transfer paths.

#### Airmass to Escape System - Path 13.

Studies by Freeman et al. indicate that this is an important energy transfer for escapes in the region between 1,220 and 1,600 psf. The energy distribution in the aircraft flow field is not uniform. Therefore, the dynamic interaction of the escape system with the flow field is characterized by rapidly varying forces and moments. This will make the task of maintaining escape system stability more difficult at the same time that stability is essential for tolerance to the high drag force levels in this high-Q region.

#### Escape System to Escape System - Path 14.

This energy transfer path includes the catapults, rockets, thrusters, drogue chutes, stabilizers, and other devices which an escape system design may employ to achieve aircraft separation, stabilization, and deceleration. Because these functions involve high load levels on the man, the design of this internal energy transfer path for the escape system must be controlled by both the man's tolerance to loading and the drag load sequence during escape.

#### Aircraft to Escape System - Path 15.

The maneuvering loads passed from the aircraft to the escape system are added to the forces required for aircraft separation. An escape system designed to operate under such maneuvering loads must make special provisions to avoid energy damage to the man. The four principal alternatives are upper torso support, reclining of the seat for ejection, a separable forebody capsule, and escape system override of the flight control system to offload the aircraft for ejection. Refer to Tauby et al. (1979), Swanson (1978:pp.47 and 72), and Grandia (1978:p.140), respectively.

#### Aircraft to Airmass - Path 16.

This last energy path encompasses the aerodynamic processes which control the transfer of energy from the aircraft to the airmass surrounding it. The energy thus transferred affects the aerodynamic moments and forces which act on the man, his protective equipment, and the escape system during aircraft separation.

## Energy Damage Injuries

All of the 16 energy transfer paths can influence the safe outcome of a 1,600 psf escape. Incidences where these transfers occur in-phase represent the greatest hazards. For example, when the baseline seat passes through an aircraft flow field at high-Q, a large aft pitch moment develops. If the seat pitches back in response, it will be in a bad position for drag forces up the spine at the worst time; i.e., at drogue inflation. If the pitch moment is countered by a thrust vector control system, the spinal thrust component would peak at the same time that the spinal aerodynamic component is maximum. Enumeration of all probable situations where energy transfers occur in-phase lies beyond the scope of this report, but this would be mandatory for a complete survey of potential energy damage processes in a 1,600 psf escape environment. Instead, a few examples are given to reinforce the general idea that, for the purpose of evaluating proposed escape system designs, injuries incurred during escape are best described as the consequence of multiple in-phase energy transfer processes.

### Head.

For the baseline system, unobstructed airflow over the top and sides of the helmet results in a large pressure differential across the helmet shell that acts to push the helmet off of the head with great force. Initially, the head bends forward during catapult stroke. Entry of the seat into the air mass at high speed results in the head being pushed back to the headrest. The head impact against the headrest can be increased significantly if a thrust vector control rocket is simultaneously countering the aerodynamic pitch moment. At the same time the oxygen mask and hose can exert large twisting moments on the helmet. At moderate yaw angles the helmet and headrest can interact with the air mass to generate relatively high pressure between them, which can push the helmet and head off the headrest support, Schneck (1980).

### Neck.

The neck carries forces resulting from the differences in acceleration between the head and torso, such as during repositioning by the inertia reel and during catapult stroke. It also carries forces resulting from differences in acceleration. Drogue inflation with the seat yawed causes the shoulder harness to apply large loads to the neck vertebrae at the same time that the oxygen mask and hose may be applying large twisting moments to the helmet. If the seat is rolling just before main chute line stretch, the resulting pitch-back moment can cause the forward main chute riser to slip between the headrest and back of the helmet as the seat rolls. This can result in part of the main chute opening shock being applied to the side of the neck. Note, the helmet canopy (Figure 3) will prevent a riser from slipping between the helmet and head rest.

## Spine.

The spine may be loaded simultaneously by the man's inertial reaction to aircraft maneuvering loads, operation of the powered shoulder retraction device, and thrusting of the catapult. After catapult separation the spine may be loaded simultaneously by seat acceleration due to sustainer thrusting, seat deceleration due to airmass pressure on the seat pan, and drogue inflation.

## CONCEPTUALIZED ADVANCED AIRCRAFT

The purpose here is to define a conceptual aircraft that has the advanced performance capability which is likely to be present in future Air Force aircraft. The conceptual aircraft will be used to discuss the initial conditions and environment likely to be imposed on the crew escape system and its occupant during emergency escape.

The general trend in high-performance aircraft includes three areas of primary concern to the designer of escape systems; higher speed at lower altitude, higher maneuvering load factors, and increased dependence on stability provided by the control system. The trend to higher speed at lower altitude means operating at much higher levels of free-stream dynamic pressure. This trend will pose serious problems for crew escape designers because the intensity of windblast and acceleration problems will increase along with the dynamic pressure. Most combat requirements for the foreseeable future can probably be met by a conceptual design that is limited to  $M = 2.2$  and 65,000-foot altitude. The operational envelope for conceptual advanced aircraft assumed for this study is shown in Figure 10. Also shown are lines of constant equivalent airspeed that represent different eras of ejection seats.

Future aircraft are likely to be capable of higher maneuvering load factors than present designs. The maneuvering load ranges to be considered in this study are:  $-G_x = 2$  to  $5 G$ ,  $+G_y = 2 G$ ,  $+G_z = 8$  to  $10 G$ , and  $-G_z = 2 G$ .

The trend to design advanced aircraft with negative static stability margins will undoubtedly continue because the advantages are significant. Conceptual aircraft are assumed to be approximately 15 percent unstable at subsonic speeds. Due to the stabilizing effect of Mach number, the aircraft will be assumed to be neutrally stable at transonic speeds and stable at supersonic speeds. These static stability regions are indicated in the conceptual flight envelope in Figure 10.

Control stabilized aircraft are obviously in trouble if the control system fails. As a consequence, such flight control systems use various degrees of redundancy in control components to reduce the probability of a failure. In addition, fly-by-wire systems have the capability to command secondary surfaces after the loss of primary surfaces. This means that, after the loss of a primary control, any other effective control can be commanded. This capability to tailor control logic to failure modes can further reduce the chances of a total control loss.

Despite the best efforts of designers to prevent total loss of control, the probability of such a loss cannot be reduced to zero. There will always be some probability that component failure or battle damage will result in loss of control. The probable consequence of a loss of control on the escape system must be considered. However, each case would have to be considered on its own merits because of the large number of failure modes that could be defined.

One possible failure mode would be where the controls fail while the aircraft is maneuvering at high G. At transonic and supersonic speeds, the aircraft would tend to hold the load factor that existed when the control failed. However, at subsonic speed, the aircraft is unstable and will probably tumble. Assuming failure conditions of  $M = 0.6$ , sea-level altitude, and  $G_z = 6$ ; the aircraft could pitch up to its ultimate strength limit in approximately 1 second. Before the pilot could evaluate his situation, the aircraft could be disintegrating around him. A second possible failure mode would be battle damage that destabilized the aircraft at transonic and supersonic speeds. In this condition, the aircraft could pitch up to its strength limit in less than 1 second. If for any reason the aircraft tumbles at high speeds, the accelerations imposed on the escape system would reach very large values in a fraction of a second and make safe ejection unlikely and aircraft fuselage structural failure likely.

The very high dynamic pressures associated with conceptual aircraft require that the escape system not tumble after ejection. Good stability and control will be required to keep the aerodynamic forces within acceptable limits. An example of the powerful influence of aerodynamic force is shown in Figure 11. The side load factor for the ACES B-1 ejection seat is plotted versus velocity for various angles of sideslip. It can be seen that 30 degrees of sideslip at 687 KEAS (1,600 psf) results in a side load factor of 31 G. A 30-degree yaw transient at high speed is not unlikely. One degree of initial sideslip can result in 30 degrees of sideslip prior to drogue line stretch. Development of a safe escape system for the conceptual aircraft will require that much more effort be devoted to aerodynamic design than has been customary in the past.

#### ESCAPE DESIGN - FUNCTION INTEGRATION PROBLEM

A primary role of the escape system is to serve as a work platform to achieve mission objectives. This role has become an ever more important driver of emergency equipment designs as the combat maneuvering capabilities of new aircraft rapidly approach the G-stress tolerance of aircrews using conventional support/restraint equipment. The assumed maneuvering capabilities of the advanced aircraft used for this study include direct side force, which will probably require the development of new body support/restraint equipment regardless of the design approach taken for the escape system. The aircraft is also capable of sustained high  $+G_z$  loads of 8 to 10 G. Because  $+G_z$  tolerance in the baseline upright seat is in the neighborhood of 7 G, the operational use of sustained  $+G_z$  above 7 G will require development of new support equipment to extend the man's tolerance.

#### High-G Stress Alleviation

In the baseline seat under high-G maneuvering loads, vision may be reduced because blood flow to the head is slowed by the hydrostatic counterpressure in the column of blood between the heart and head. The anti-G suit, M-1 maneuver, and 30-degree seat back angle have been successfully employed in operational conditions to increase the man's G-tolerance. (Refer to Burton et al. (1980).) The pelvis and leg-lifting seat, the fixed reclined seat, and positive

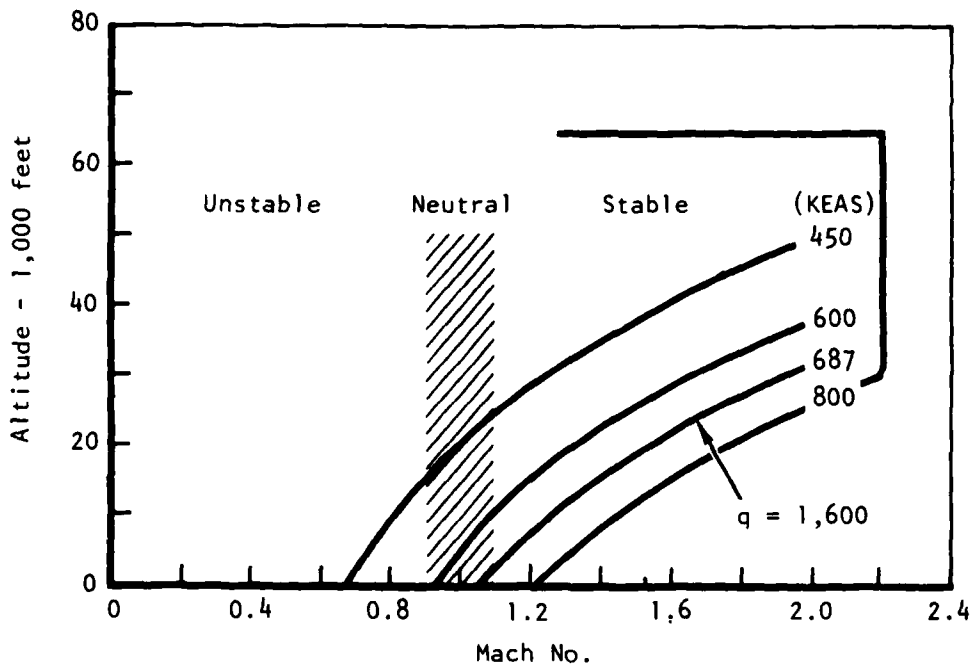

Figure 10. Operational Envelope for Advanced Conceptual Aircraft

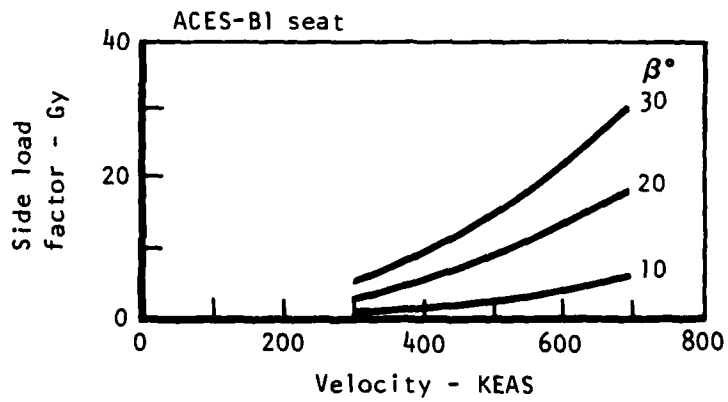

Figure 11. Ejection Seat Side Load Factor Versus Velocity

pressure breathing are the principal prospective techniques for further increasing G-tolerance. The 30-degree, pelvis and leg-lifting, and the fixed reclined seats employ the technique of lowering the effective height of the column of blood between the head and heart.

The 30-degree seat facilitates a hunched-over posture. This posture lowers the heart-to-head column about 25 percent, and bending over the torso bladder in the anti-G suit can help to relieve abdominal muscle fatigue associated with the M-1 maneuver by providing a stiff surface for the abdominal wall to press against. The hunched-over posture also brings the head closer to the head-up display (HUD). However, because the HUD viewing cone is fixed, the dropping of the head must be compensated for by raising the seat pan to a position which allows HUD viewing from the hunched-over position. Note, this practice\* is in conflict with the conventional cockpit geometry based on an unloaded design eye position. Advantages of the 30-degree approach are retention of conventional escape system geometries and excellent external vision. Disadvantages with respect to a reclined seat approach are a relatively large canopy volume and greater physical exertion to reduce heart-to-eye height.

The pelvis and leg-lifting seat lowers the effective heart-to-head column height by raising the torso while maintaining the head in a fixed position. (Refer to Grandia et al. (1978:p.53), and Marti et al. (1978:p.7).) Advantages are retention of the conventional ejection seat geometry, and higher G-tolerance with less exertion. The need for a new cockpit geometry is a disadvantage.

The fixed reclined seat improves G-tolerance the same way as the pelvis and leg-lifting seat. Additional advantages of the fixed reclined seat are smaller forebody volume and possibly better escape capabilities at high-Q and under maneuvering loads. Disadvantages are required development of new cockpit and escape system geometries and subsystems, and a reduction in external vision.

The positive pressure breathing technique involves the use of a vest inflated with breathing air which pumps pressurized air to the lungs as the chest expands during inhalation. The pressurization of the lungs and thorax should help counter the G-induced hydrostatic back pressure at the heart which should improve G-tolerance and reduce fatigue from repeated G-loadings. (Refer to Shaffstall et al. (1979).)

#### ESCAPE FROM A NONCLASSICAL AIRCRAFT

This study considers the requirements for an escape system for a conceptualized advanced aircraft with negative stability margins. Such aircraft are a departure from most conventional aircraft in that loss of flight control authority in the negative stability region of the flight envelope results in rapid divergence of the aircraft attitude from its flight path. Determination of the need to provide escape capability in this region will require analysis

\*Reported in communications with F-16 test pilots at Edwards Air Force Base Flight Test Center.

of the probabilities of timely ejection initiation, aircraft behavior after loss of controlled flight, and probability of collision with the aircraft during escape.

#### Probabilities of Escape Environments

The probability of high Z-axis aircraft loads during future ejections from nonclassical, actively stabilized aircraft will be an important factor in the selection of an escape system design approach for these aircraft. Therefore, such probabilities will also be good indicators of the relative importance of alternative areas of future biomechanical research. Quantitative probability estimates must await detailed reliability and survivability/vulnerability analyses. However, in the meantime, future ejection environments may be divided into conceptual categories which invite subjective probability estimates and illustrate the potential significance of the actual probabilities.

#### Electronic Flight Control.

Grandia et al. (1978:p.140) noted that for the next generation of fighters the electronic flight control system (EFCS) should be considered as an integral part of the airframe structure because of its essential role in maintaining aircraft stability in the unstable subsonic and neutrally stable transonic regions of the flight envelope. If the EFCS is functioning and the aircraft is within the bounds of controllable flight at ejection initiation, then the ejection should take place from a stable and unloaded aircraft, assuming escape system override of flight control commands is implemented. If the EFCS stops functioning when the aircraft is in the unstable subsonic flight region, the aircraft will begin tumbling within 1 second, and the probability of successful escape will be low. Loss of EFCS functioning in the neutral stability region can result in sustained G-loading of the aircraft because it tends to remain in whatever its attitude was when control was lost. Because the EFCS can be programmed to adapt to system failures and even structural damage and can be given multiple redundancy without major penalties in weight or complexity, future EFCS's are expected to have both high reliability and survivability.

#### Analysis by Stability Region.

The lower part of Figure 12 shows for a generalized advanced fighter (15% unstable) the three basic stability regions of the Mach/altitude space: unstable, neutral or transitional, and stable. The upper part of the figure shows a purely conceptual bar chart linking relative frequency of emergency conditions which would prevent continued safe flight with the three generalized stability regions. The emergencies within a particular stability region are segregated by the condition of the flight control system, either functioning (OK), not functioning (OUT), or aircraft beyond controllable flight boundaries (OUT OF CONTROL). The ejections within a particular EFCS status are segregated by knots equivalent airspeed (KEAS). Remembering that the relative distributions among categories indicated in the figure are guesswork only, for the purpose of discussion note the following features:

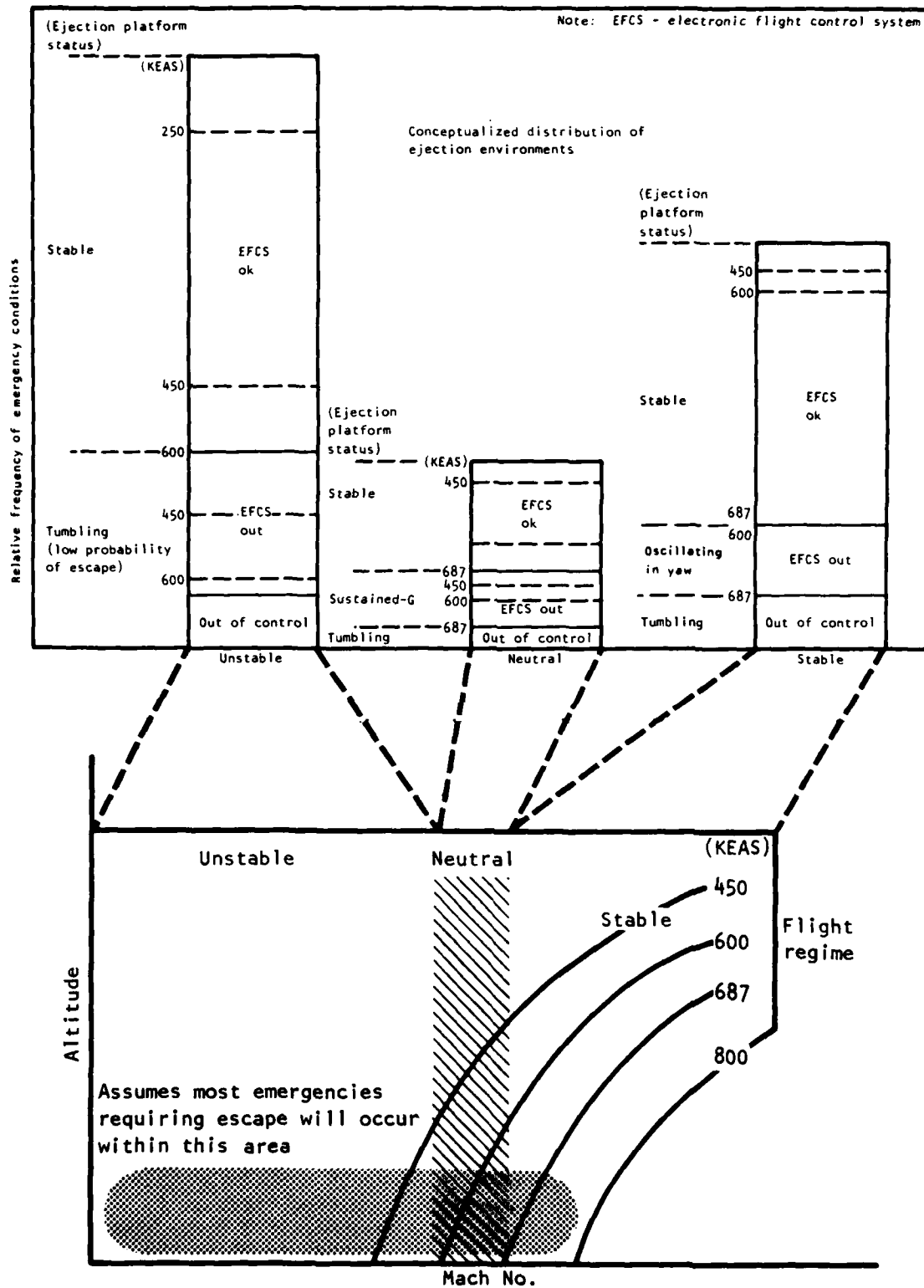

Figure 12. Hypothetical Distribution of Ejection Environments for a Future Fighter With 15% Unstable Aerodynamics

- If the EFCS goes out in the unstable flight region, then the aircraft will tumble within a few tenths of a second and the probability of successful escape will be relatively low regardless of the escape system design. Note: reaction time to initiate escape is approximately 2 seconds.
- If the EFCS is functioning during an emergency in the unstable flight region, then the aircraft will probably be stable and the G-load will be low and/or dropping.
- A situation of sustained G-loading of the ejection platform is likely only in the neutral stability flight region when the EFCS is not functioning. The frequency of occurrence of this combination of circumstances should be relatively low.
- Loss of EFCS functions in the stable flight region does not result in immediate tumbling.

These features of the bar chart are the graphically stated premises of an argument which concludes that the most probable environment for an ejection from an advanced fighter would be a stable aircraft. The next most probable environment would be a tumbling aircraft with a low likelihood of successful escape. The third most probable environment would be sustained G-loading which requires special design considerations for safe aircraft separation.

The intent of this conceptual probability analysis of escape environments is to emphasize the importance of the reliability/survivability of the EFCS for the selection of a design for an escape system for the next generation of fighters. The major impact of EFCS reliability will be in the relative proportions of stable to tumbling escape environments. The proportion of sustained-G environments is likely to be relatively low in any case because of the likelihood of an escape system override of the EFCS being used to offload the aircraft and the low probability of ejecting in the relatively narrow (0.2 to 0.3 Mach wide) neutral stability zone.

#### Separation From a Maneuvering Aircraft

If from a failure modes effects analysis of EFCS's for future unstable fighters it is determined to be cost effective to give an escape system the capability for separation from a maneuvering aircraft, one problem would be that of attitude positioning. For a 30-degree seat back angle, the 20- to 25-degree aircraft flight path angle at maximum G would make the effective seat attitude 50 to 55 degrees. Swanson (1978:p.127), using the tri-axial seat pan acceleration criterion defined in MIL-S-9479 noted that, for drag on a conventional seat and neglecting other windblast effects and rocket thrust, a maximum Q tolerance of 1,850 psf occurs at a 20-degree seat attitude. This decreases to 1,400 psf at 50 to 55 degrees. To achieve safe escape at 1,600 psf with a conventional seat and restraints there is a need for either an attitude positioning capability to immediately position the seat to a 20-degree attitude or a drag countering rocket thrust. However, if a large steerable rocket below the seat pan as described by Beale (1975) is to be the source of

the positioning moment, then the thrust vector would slew through the spinal axis before a pitch down positioning moment could become effective. This would reduce  $Q$  tolerance substantially below the 1,400 psf limit due to drag alone. A better design approach would be to locate a second nozzle above shoulder height with a thrust-line 50 degrees below the normal to the seat back but above the seat-man center-of-gravity. Seventy percent of this thrust would counteract the drag load in the spine while providing a pitch down moment to position the seat for drogue inflation. This upper nozzle would be selected only where the seat reached a predetermined pitch angle-of-attack or pitch rate.

A fixed reclined seat escape system would encounter a similar conflict between the requirement for attitude positioning and generation of an adverse thrust vector component along the spine. Determination of the importance of this conflict at 1,600  $Q$  requires

- Detailed aerodynamic coefficients for the reclined seat including rocket plume effects
- Aircraft flowfield effects on seat aerodynamic coefficients
- Six degree-of-freedom simulation of separation and stabilization including catapult dynamics
- Simulation of spinal column response to forces delivered through a concave seat back and non-rigid pelvis support

## FOUR APPROACHES TO ADVANCED ESCAPE SYSTEM DESIGN

The four escape system design approaches described in this section may be compared one with another along several measurements of design characteristics, such as weight, complexity, reliability, development risk, cost, integration with normal aircraft operations. However, for the purposes of this study, the design characteristics of primary interest will be those which are intended to increase the maximum allowable dynamic pressure and maneuvering G for a safe escape.

### ADVANCED CONVENTIONAL

The objective of this design approach is to improve the conventional (MIL-S-9479) open ejection seat with active pitch, roll, and yaw stabilization with full torso restraint against  $+G_z$ ,  $-G_x$ , and  $+G_y$  and additional windblast protection for the head, arms, legs, and torso. To increase pilot tolerance of maneuver load stress, the conventional seat could also be fitted with a pelvis and leg-lifting feature which would retract for ejection. Refer to McDonald (1979), Grandia et al. (1978), and Marti et al. (1978). However, because this feature would not directly improve the allowable Q or maneuvering loads at ejection, it was not included in this configuration. Recent wind tunnel tests of the ability of an inflatable afterbody to stabilize a conventional open seat revealed an unacceptably large attitude control dead space. Therefore, for this program, a new yaw stabilization concept was identified with an emphasis on precise high-power control of yaw attitude.

#### Yaw, Pitch, and Roll Stabilization

Stabilization augmentation can be provided by several different approaches. The advanced conventional seat could be yaw stabilized by a pair of small drogue chutes which are attached to hinged booms which deploy laterally from the seat bucket sides after clearance from the cockpit. (See Figure 7.) The booms are intended to place the trim drogues away from the seat flow field and to decrease the required drogue size by providing a longer moment arm. An electronic control system generates yaw attitude error signals which are used to control the braking of two reels of wire cable which connect to the drogues. A yaw moment is generated by applying the brake on one of the drogue reels while releasing the other. Braking both reels at once cancels the moment. The advantages of this approach are that it can be active very quickly, and can apply large, precise, instant yaw attitude control moments for precision yaw control for relatively long periods with minimal drag and with little weight penalty.

A second approach would use a thrust vector control (TVC) system similar to that described by Beale (1975) provides moments for pitch attitude positioning, roll control, and thrust for aircraft separation. A more sophisticated system would include pitch and roll attitude positioning for vertical seeking, and consequently better adverse attitude and sink rate/dive angle performance.

A minimum system would use a standard fixed rocket catapult and a third brake-controlled drogue deployed from a boom above the headrest to generate pitch attitude positioning moments and an ACES-II STAPAK Vernier rocket, turned 90 degrees, for roll control moments. The three-drogue strategy for increasing allowable psf is to achieve positioning to optimum attitude quickly with minimal inertial load components in the spine and to hold the optimum attitude through drogue inflation shock.

#### Upper Torso Support Against +Gz, -Gx, and +Gy

The advanced conventional seat considered in this study is equipped with a multipurpose torso support garment (Figure 5) which is intended primarily to increase maximum allowable maneuvering loads and psf at ejection by providing additional support to the torso against +Gz and -Gx loads. In addition, the garment provides for an increase in the maximum ejection altitude through support of positive pressure breathing. While the advanced seat is intended to have precision yaw attitude control, the torso garment is also intended to increase the maximum allowable initial yaw attitude at ejection by greatly increasing support of the torso against +Gy loads. In addition to these escape-related features, the torso garment is intended to improve normal maneuvering +Gz tolerance by providing torso pressurization which will reduce muscle fatigue and by support of positive pressure breathing which will increase blood pressure in cerebral arteries, Sears et al. (1980). The garment also broadly supports the torso against +Gy loads generated by direct side force maneuvers. The design strategy for this lateral support is to provide support from the side of the seat opposite the Gy load. To accomplish this, the torso garment is attached to the seat by cables which carry lateral loads around the front and back of the torso to inertia reels on the opposite seat side. This arrangement requires only a small lateral seat displacement before lateral torso support is encountered and generates smaller torques on the torso than would single-strap torso restraint designs. The broad lateral support provided should make possible longer exposures to alternating lateral loads than the shoulder support pads being developed for the AFTI/F-16, General Dynamics (1980:pp.5-12 and A-157). The torso garment lateral restraint is also designed to avoid the interference with arm motions caused by rigid lateral torso supports as reported by McDonald (1979:p.12). In terms of skeletal kinematics, the broad lateral support of the rib cage provided by a torso support vest should support the spinal column against lateral flexing under lateral load. (Refer to Olsen (1971).)

#### Windblast Protection

The advanced conventional seat employs four protection concepts for increasing the maximum allowable psf at ejection.

- Stagnation canopy for helmet retention and lateral helmet support
- Two stagnation fences, one on either side of the torso, for arm and leg protection, pretensioning of the -Gx restraints prior to drogue inflation, and more uniform pressure distribution across the abdomen

- Leg restraints integrated with the anti-G suit
- Inflatable torso restraint garment for better lateral support and G-tolerance during combat maneuvering, and for better  $+G_z$ ,  $-G_x$  and  $+G_y$  support and compression of the rib cage before windblast entry during escape

#### Stagnation Canopy for the Helmet.

Payne et al. (1975) found that lift forces in the neighborhood of 400 to 500 pounds act on the helmet during a high-speed ejection. They also found that the force was due to very low pressure on the top of the helmet. The resultant force is dangerous because it can cause failure of the cervical spine, loss of the flight helmet and/or facial damage. Loss of the helmet would leave the face directly exposed to the windblast and make parachute landing much more dangerous. Figure 3 shows a possible configuration for the helmet canopy. The canopy stagnates airflow over the top of the helmet, which should eliminate the helmet lift force. The stagnation canopy deploys forward from the top of the headrest over the helmet. As it deploys, it pulls out two support cables on either side of the helmet. These cables support the canopy against the lift generated by the windblast and provide lateral support for the helmet. The cables release at seat/man separation, allowing the canopy to flip up out of the way. The canopy frame is made from an aluminum tube, the arms of which are stored inside the lateral flaps of the pilot chute cover. A rectangular piece of reinforced fabric is attached to the base of the tube and along the top of the headrest. Additional head protection is provided by modifying the breathing mask to receive air from the helmet, which is in turn supplied from a hose connected to its rear quarter. This will reduce torques on the helmet due to air drag on the baseline oxygen hose.

#### Stagnation Fences for the Arms, Legs, and Torso.

The concept of fabric stagnation fences which are deployed on either side of the torso, is described elsewhere in this report. (See Figure 4.) Studies leading to the development of this concept includes those of Woodward and Schwartz (1980), Schneck (1980), Cummings et al. (1980), Payne (1974), and Naval Air Development Center (1979). The reliance on flow stagnation to provide windblast protection to the arms allows the use of very simple upper arm restraint collars to position and hold the arms within the region of stagnation. In comparison, Cummings et al. (1980) studied designs to restrain the arms against direct windblast exposure and found biomechanically acceptable designs to be complex and encumbering. It could be possible that this concept will worsen the aerodynamic stability of the basic seat. In this case, the concept might require of an active seat stabilizing system an additional moment-generating capacity to compensate for the destabilizing effects. On the other hand, the stagnation fence concept might improve basic seat stability by moving the effective center of pressure backward relative to the seat/man center of mass. By stagnating airflow around the torso, pressure in the space between the seat back and man will be greatly increased. Therefore, the net pressure force on the seat will be much larger, while that on the man will be

much smaller. This will create a relative separation force between the man and the seat which should pretension the  $-G_x$  restraints. The combination of pretensioning and precise attitude positioning will produce maximum deceleration tolerance and allow use of a larger decelerator.

#### Integrated G-Suit Leg Restraint.

This concept is essentially the same as that described by Cummings et al. (1980), and presented in Figure 9.

#### RECLINED SEAT

The reclined seat configuration used here is basically that proposed by Tauby et al. (1979). (See Figure 8.) The strategy employed for increasing maximum allowable psf is to reduce the drag area of the seat and, therefore, the rate of energy transfer to the airmass by:

- Rotating the seat to a zero-degree back angle for ejection so that at a zero-degree angle of attack (AOA) the spinal axis is parallel to the flight path
- Retracting the feet to a platform extending forward from the bottom of the seat bucket
- Flattening the seat by increasing the angle between the pan and backrest from 96 to a fixed 150 degrees
- Using a 2-foot-diameter drogue as compared to a 5-foot-diameter drogue on the baseline seat

In addition to reducing the drag area, the reclined configuration employs a long-burning (2 seconds), high-impulse (8,000 pound-second), gimballed rocket motor with a vertical steering TVC system. This combination of rocket and steering control is intended to provide a large reduction in sink velocity and, therefore, decrease the need to use drogue drag force for this purpose.

While the Tauby study did not include escape from a G-loaded aircraft, this study does. Accordingly, the strategy for increasing the maximum allowable aircraft maneuvering load is to position the torso so that the rocket thrust is aligned with the axis of greatest acceleration tolerance, the X-axis, and is perpendicular to the spinal axis.

#### Pitch, Roll, and Yaw Stabilization

Pitch and roll attitude positioning is handled by the gimballed rocket motor and the vertical steering control. A zero-pitch AOA would be the normal control target. However, there are two exceptions to this rule.

- o Low-altitude high sink rate

- High aircraft maneuvering loads

In the case of low-altitude high sink rate, the vertical steering control would first attempt to drive the seat to a zero-roll attitude and then to pitch the seat up to a positive AOA in an effort to maximize the vertical acting component of the rocket thrust. In the case of high maneuvering loads, the control system would attempt to maintain the AOA which existed at initiation in an effort to maximize that component of the rocket thrust which is perpendicular to the long axis of the aircraft. Both of these exceptions are similar in their attempts to maximize the thrust component toward the objects to be avoided at the expense of a nonzero AOA. The increased drag, resulting from the positive AOA's in both cases, causes an increase in  $+G_z$ , which is traded off to obtain ground and aircraft clearance. This trade-off is mitigated by concurrent  $+G_x$  from drag and the rocket thrust which holds the spine in alignment against the seat back for maximum tolerance.

### Windblast Protection

The principal strategy for windblast protection is the preclusion of direct interaction of the man with the air mass by the interpositioning of a shield in front of the lower legs to deflect the air mass around the man's body. The man's kinetic energy is passed through the body supports and restraints to the seat and then through the shield to the air mass. Proper deployment of the shield requires that the feet be in a particular position, making it necessary to attach positioning restraints to the shoes. The head and arms will be embedded in a strong reverse-flow turbulence behind the shield. The arms may require active restraint at the wrists to prevent this turbulence flow from dragging them into the airflow surrounding the seat. The head is protected by an inflatable bladder integrated with the helmet chin strap and connected to its inflation source concurrently with the oxygen supply hose.

### PARTIAL ENCAPSULATION

The partially encapsulated configuration for this study is shown in Figure 13. The configuration is the same as the advanced conventional seat, with addition of a deployable airflow stagnation canopy. The strategy for increasing the maximum allowable psf is to shield the occupant from direct interaction with the windblast by trapping a pocket of stagnated air in front of and around his body. This is accomplished by erecting a fabric canopy which encompasses the man's head, torso, and upper legs. The flexible rim of the canopy is its main structural element. The rim is supported above the helmet by a metal frame which is thrust forward from the headrest at initiation. The lower ends of the rim are attached to the forward area of either seat bucket side. The canopy is initially inflated by airflow deflected off the man's body. After initial inflation, the motion of the seat maintains the stagnation pressure which keeps the canopy inflated. By stagnating the airflow around the man's body, the canopy eliminates helmet lift, dislodgement pressure on the arms, distortions of the soft tissues, possibility of ram air ingestion, and "squeeze" type hyper blood-pressure problems due to differential pressurization of the torso and head. Deployment of the canopy is by powered retraction of the canopy rim

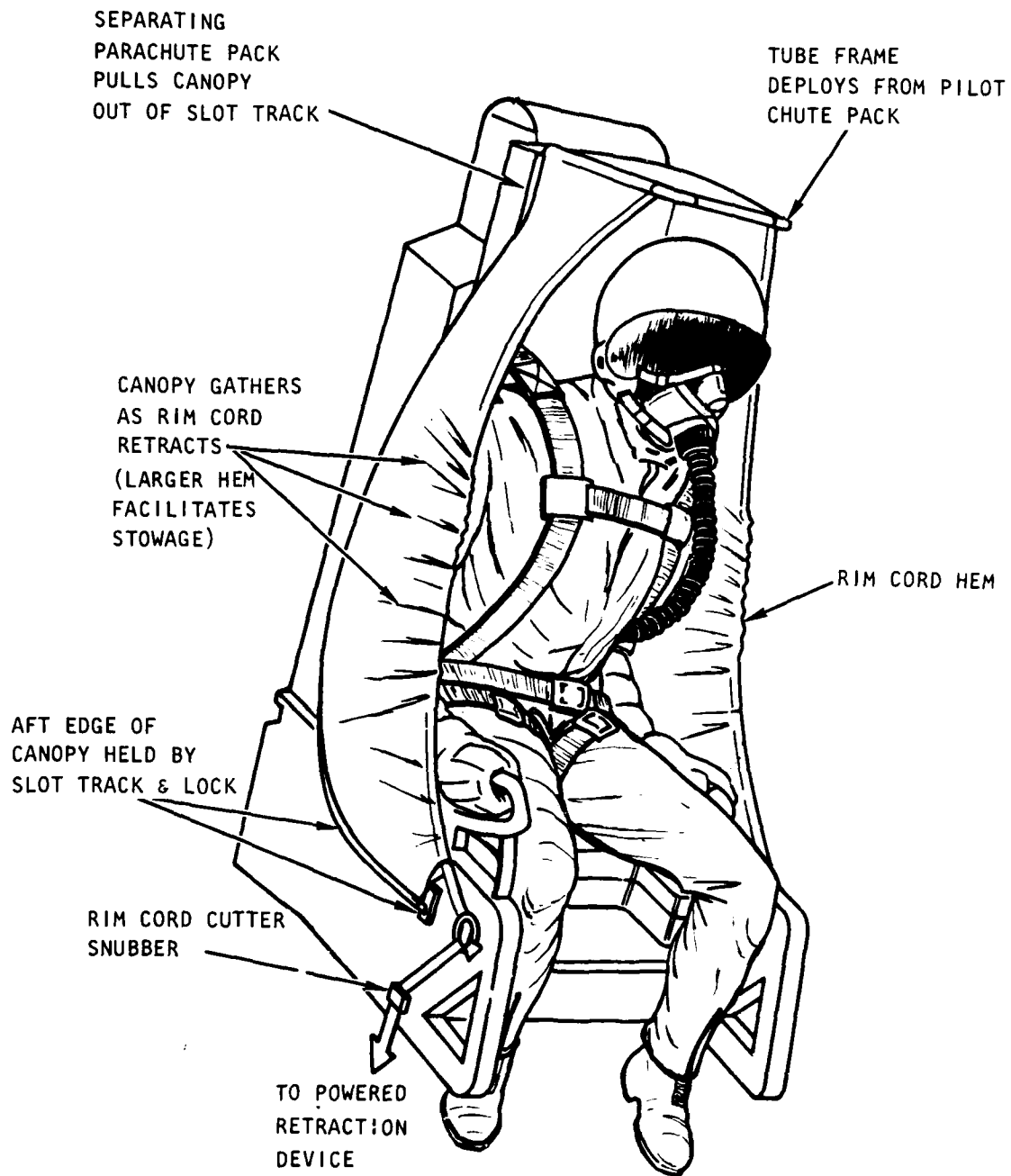

Figure 13. Partial Encapsulation Concept

cords. The metal frame is deployed by high-pressure gas. Inflatable bladders, similar to those described by Woodward et al. (1980), guide the canopy over the shoulders and arms during deployment. The canopy is attached to the seat by a slot track which allows the canopy to be pulled off the seat by the motion of the main parachute pack. The slot track concept is adapted from the new arm restraint system on the Swedish Saab escape system RS 37 gen 2. (Refer to Saab-Scania (1980).) The canopy is released by cutting the rim cords and lap belt supports and unlatching the lower canopy hem at the lower end of either slot track. The strategy for increasing the maximum allowable maneuvering load at ejection is to support the upper torso mass against vertical seat accelerations using the upper torso garment described for the advanced conventional seat configuration.

### Pitch, Roll, and Yaw Stabilization

The canopy partial encapsulation configuration is stabilized in a manner identical to that described for the advanced conventional seat. By distributing stagnation pressure over a large area of the seat back and seat pan the canopy will move the effective pressure center aftward. This will improve the system stability in the neighborhood of zero AOA.

### Support/Restraint

The fabric canopy greatly reduces the direct transfer of energy from man to airmass. Therefore, his kinetic energy must be removed through the restraint system. To this end, the seat is fitted with a torso restraint garment as shown in Figure 5. The legs are restrained by the integrated g-suit/leg restraint. The arms are restrained by retractable collars attached above the elbows.

### FULL ENCAPSULATION

The full encapsulation configuration selected for this study was studied by Swanson (1978). It is a separable forebody concept with an integral conventional ejection seat such as the ACES-II. In low-speed ( $< 350$  KEAS), low-altitude ( $< 40,000$  ft), low-maneuvering load ( $< 2$  G) situations, only the ejection seat is used. When these environmental levels are exceeded, the separable forebody is used first. Then after speed, altitude, and load levels are within tolerable limits, the ejection seat is used. Separation of the forebody from the aircraft is passive in that no separation forces are applied to the forebody. The strategy for increasing the maximum allowable psf at ejection is to keep the man completely separated from the airmass. Swanson's preliminary study found that the psf allowed by the acceleration radical criterion exceeds 2,000 psf. The strategy for increasing the maximum allowable maneuvering load at ejection is to make the separation of the forebody capsule passive. The maneuvering load, being the only escape load, will probably exceed the structural limits of the aircraft. A preliminary stability analysis for small AOA (refer to Swanson (1978: p.108)) indicated the forebody capsule would be stable up to at least Mach 2. Therefore, no special body support

restraint equipment is required to protect against loads due to forebody tumbling or stabilization. Also, because cabin pressure is retained, no special breathing equipment is provided for escape at high altitudes. However, positive pressure breathing equipment may be used to improve tolerance to air combat maneuvering +Gz and as a cabin pressure backup, Shaffstal (1979).

## ANALYSIS OF BIOMECHANICAL RESEARCH REQUIREMENTS

In this section, each of the four escape design approaches is analyzed for implicit biomechanical research requirements. For each approach, four general aspects of performance are considered:

- Windblast environment and protection
- Preejection considerations, including ejection initiation, body positioning, and deployment of both body support/restraints and shielding
- Ejection forces and the effects of aircraft motions at the time of ejection
- Effect of forces on the occupant delivered by the seat after separation from the aircraft, i.e. stabilization response

For each of these aspects of performance, Table 1 compares the four design approaches in terms of the need for biomechanical research into the energy transfer processes described in the background section. This table shows that the fully encapsulated approach requires far less biomechanical research than the other three. The advanced conventional and partially encapsulated seats will require substantial research in all four performance categories. The reclined seat will require research primarily in the areas of windblast protection and stabilization response. In the windblast area, the transfer of energy from man to the reclined seat shielding devices and support/restraints must be researched. In the area of stabilization response, research must be done on the aerodynamic stability of the reclined seat and, potentially, on the man's response to high drag loads resulting from pitch and/or yaw angles at aircraft separation.

### ADVANCED CONVENTIONAL

#### Windblast

The windblast environment and protection afforded by the advanced conventional design approach should be researched through the following programs:

- Functional mockups of helmet canopy, stagnation fences, arm restraints, G-suit leg restraints, and torso vests
- Low-speed wind tunnel tests with human subjects
- Instrumented test article for high-speed wind tunnel tests of helmet canopy, stagnation fences, braked drogue stabilizers and yaw axis mobility, and G-suit leg restraints with lower leg support strap

These research programs should be designed to test the central hypotheses of the advanced conventional windblast protection designs at the earliest possible

Table 1

RELATIVE SIGNIFICANCE OF ENERGY PATHS TO FOUR ESCAPE DESIGN APPROACHES  
WITHIN FOUR BIOMECHANICAL PROBLEM AREAS

Energy Transfers During Escape		Escape System Configurations															
		Advanced Conventional				Reclined				Partially Encapsulated				Fully Encapsulated			
From	To	WB	PP	AM	SR	WB	PP	AM	SR	WB	PP	AM	SR	WB	PP	AM	SR
1	Man - Aircraft	•								•							
2	Man - Escape System	•	•		•	•	•		•	•	•		•	•			•
3	Man - Protective Equipment	•			•	•			•	•			•				
4	Man - Man	•	•		•	•			•	•			•				
5	Protective Equipment - Aircraft	•			•	•			•	•			•				
6	Protective Equipment - Escape System	•	•	•	•	•		•	•	•	•	•	•	•			
7	Escape System - Airmass	•			•	•			•	•			•				
8	Airmass - Man	•	•						•	•			•				
9	Escape System - Man		•	•	•	•			•		•	•	•		•		
10	Protective Equipment - Man		•	•	•					•	•	•	•				
11	Airmass - Protective Equipment	•															
12	Escape System - Protective Equipment	•	•	•	•					•	•	•	•				
13	Airmass - Escape System	•			•	•			•	•			•				
14	Escape System - Escape System	•		•	•	•		•	•	•		•	•				
15	Aircraft - Escape System		•	•								•					
16	Aircraft - Aircraft	•			•	•			•	•			•				
Biotechnology integration complexity factor		13	8	6	12	10	1	2	10	12	6	6	12	2	1	0	1

WB - Windblast protection  
 PP - Prepositioning, restraint tightening, and initiation  
 AM - Aircraft motion effects on ejection forces  
 SR - Stabilization response of the body

time. These hypotheses include restraint tensioning from the torso stagnation fences pressurizing the backrest and seat pan, greater range and speed in yaw stabilization from braked drogue chute stabilizers, helmet retention from the helmet canopy and new oxygen mask, safe leg restraint from the modified g-suit and lower leg support strap, safe arm restraint from the upper arm collar and lateral torso stagnation fences, and torso internal pressure gradient flattening and overpressure implosion protection from the inflatable torso vest.

### Prepositioning

Successful operation of the advanced conventional seat requires the deployment and/or retraction of several subsystems prior to catapult initiation. These events are inflation and lifting of the torso vest, deployment of the helmet canopy, retraction of the upper arms and deployment of the torso stagnation fences, and retraction of the G-suit restraint straps. The feasibility of accomplishing these events in the neighborhood of 120 milliseconds from initiation should be researched through the following programs:

- Functional mockups of the helmet canopy, torso vest, stagnation fences, and arm restraints
- High-speed helmet canopy deployment
- Static torso vest support of upper torso
- Centrifuge-based tests of torso vest inflation and lifting with simultaneous shoulder retraction
- Catapult or drop tower tests of torso vest support of dynamic loads
- High-speed arm retraction and stagnation fence deployment

Again, these research programs should be designed to test critical prepositioning design hypotheses at the earliest possible time. The most important hypothesis is that inflating and lifting the torso vest will offload a large proportion of the upper torso mass from the spinal column during separation thrusting. This hypothesis should be tested by the static, centrifuge, and impact tests. Other important hypotheses are that the helmet canopy, arm restraints, and torso stagnation fences can be deployed and locked in 0.1 to 0.2 seconds.

### Aircraft Motion

The advanced conventional design strategy for separation from a maneuver loaded aircraft is based on a larger than baseline total separation force (thrust plus drag). Implicit in the design is the hypothesis that upper torso and pelvis support and a pitch-down seat attitude will enable the occupant to sustain this large force without injury. When in a pitched-down attitude, the combination of separation thrust and drag deceleration acts along the X-axis of the man's

body as shown in Figure 14. The strategy is to offset separation thrusting forces in the spine with the spinal component of the drag inertial response while supporting the upper torso against the larger  $-G_x$  response. If this strategy is successful, then safe escape under aircraft maneuvering loads might be achieved with the ACES-II seat through incremental engineering development of a selectable catapult/guide rail system and a thrust vector control system as shown in Figure 15.

The following programs would be required to verify the biomechanical hypotheses implicit in this strategy:

- Functional mockup of the torso vest for  $-G_x$  load support
- AMRL accelerator sled tests of torso vest  $-G_x$  support with human subjects
- Modification and running of a 6-DOF ejection computer simulation model incorporating forward seat rotation, a TVC booster rocket, torso stagnation fence configuration drag and stability, and forebody flow field escape system interaction effects
- Evaluation of computer simulation results against analyzed torso vest test data and appropriately modified acceleration tolerance criteria

### Stabilization Response

The advanced conventional seat employs a pair of braked stabilizer drogues for yaw stabilization, torso airflow stagnation fences for increased drag on the seat, and a thrust vector control system for generation of pitch and roll stabilizing moments. Several strategies are involved:

- Use drogue drag to generate yaw stabilization moments freeing the thrust vector control systems to control pitch and roll for maximum separation thrusting and, possibly, vertical steering
- The small size and short riser lines of yaw stabilizer drogues will provide for rapid deployment on entering the air mass. The design is also able to apply and release maximum yaw correcting moments nearly instantaneously. These features should minimize yaw attitude excursions.
- Once yaw attitude is zeroed, the stabilizer drogue lines will be released slowly in small alternating bursts. This will provide a relatively long period of yaw stability which, in turn, will permit delay in deployment of the decelerator drogue until dynamic pressure has decreased to a safe level.
- The yaw stabilizing drogues will be able to maintain the seat in a zero yaw attitude through decelerator drogue opening shock. This will preclude the application of opening shock loads on a yawed seat.

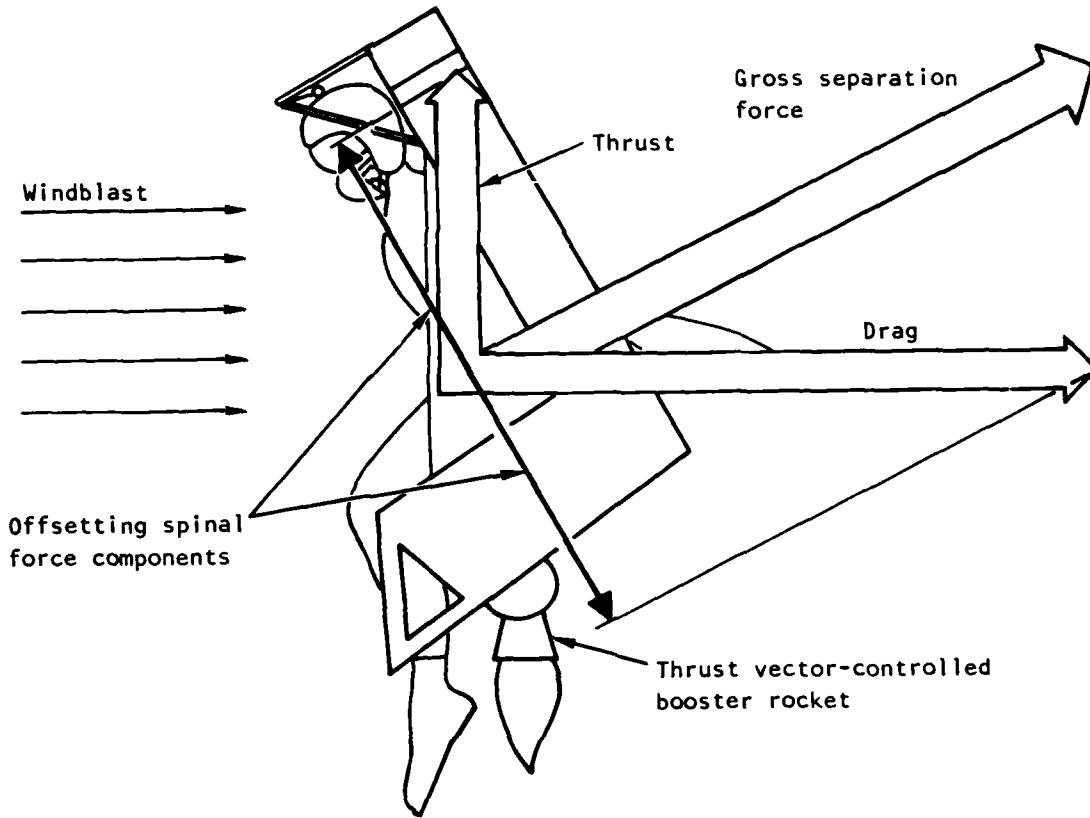

Figure 14. Attitude for Greatest Combined Drag and Separation Forces on a Conventional Seat

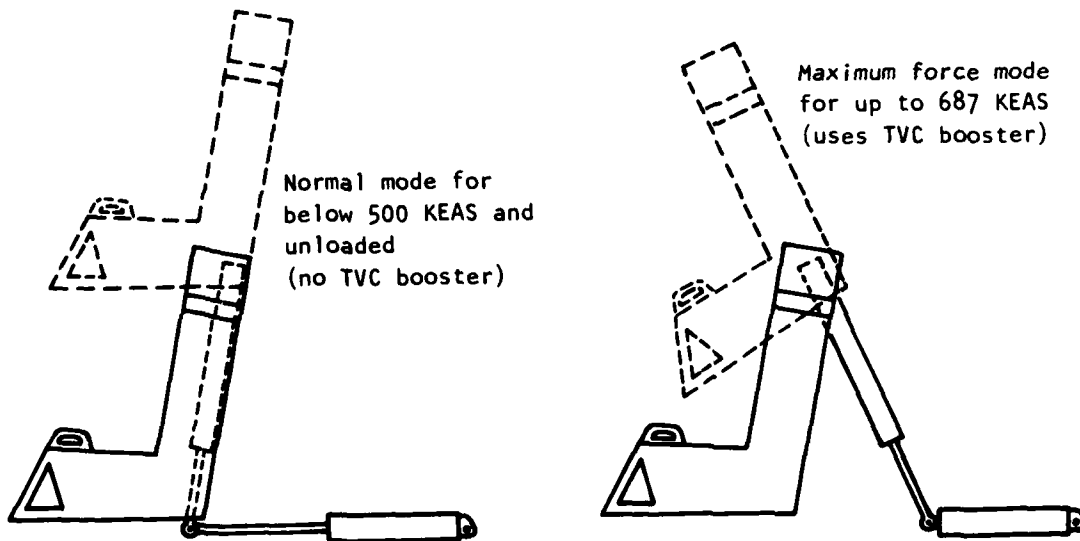

Figure 15. Normal and Maximum Force Ejection Modes for a Conventional Seat

- Perform a biomechanical research study to generate tolerance criteria to be applied to the environments derived from the preceding studies: human response to pitch and yaw accelerations under high +G<sub>z</sub> and -G<sub>x</sub> restraint loading
- Perform an analysis on the results of the preceding studies to determine the dimensions of the safe escape envelope in terms of aircraft loading and dynamic pressure
- Conduct integrated hardware tests

## RECLINED SEAT

### Windblast

The windblast protection strategy for the reclined seat is predicated on three concepts:

- Attitude positioning and long-duration attitude control
- Ejection in a supine position with knees up
- Inflation of a blast shield to deflect the airmass around the man

The principal hypotheses in this strategy are that deceleration forces can be applied to the man safely, and that the placement of an inflatable blast shield at the feet is a practical and effective means of deflecting the airmass around the man. The critical part of the ejection sequence will be attitude positioning during aircraft separation. Ejection from a maneuvering aircraft will result in the seat entering the airmass with a nonzero pitch attitude. Also, interaction with the aircraft flow field will cause a large pitch-up moment on the seat. Attitude positioning will be accomplished by aiming the thrust vector aft of the seat CG to produce a counterbalancing pitch-down moment. Drag area and, therefore, deceleration force will increase rapidly with seat pitch attitude above 25 degrees. The aft aiming of the separation rocket and pitch-induced drag increment will increase the total deceleration force in the spine. To confirm the hypothesis of tolerable deceleration forces under these conditions will require the following research programs:

- Construct a functional mockup of the support/restraint and windblast protection subsystems suitable for accelerator and centrifuge testing: multipurpose pelvis support, deployable support for ischial tuberosities, torso vest, headrest, inflatable blast shield
- Through a series of human subject tests on the AMRL accelerator and centrifuge, refine the restraint design to flight-worthy status, and determine the effect of the supine support/restraint configuration on human acceleration response and tolerance

- Determine the human tolerance for restraint/support forces applied to the lower legs by the inflatable blast shield by integrating wind tunnel, accelerator sled, and biomechanical research programs.
- Program a computer simulation model of seat occupant spinal compression and knee joint loading to obtain attitude, dynamic pressure, and altitude boundaries for safe escape

### Prepositioning

The two major reasons for prejection positioning of the body and restraints on the baseline upright seat are alignment of the spinal column and control of system CG. On the reclined seat, the spinal column is held in alignment by constant contact with the seat back support surface. The absence of a supporting seat pan makes CG control difficult. However, the capability of the thrust vector control to compensate for CG offsets and the fact that CG shifts will generally be in a favorable direction probably makes CG control unnecessary. Therefore, the baseline prepositioning problems are eliminated by the reclined seat configuration. However, a new preposition problem is introduced, namely the tensioning of the restraint load paths which will carry the +Gz response to seat deceleration and separation thrusting. This pretensioning is required to preclude loading of the knee joint with +Gz loads. Verification of this hypothesis should be accomplished by including restraint pretensioning in the restraint/support development/test program described in the preceding section.

### Aircraft Motion

In escaping from a maneuver loaded aircraft the reclined seat escape system must pitch up and thereby compromise its low drag feature in order to generate adequate net separation force between the seat and aircraft. In order to do this without exceeding the +Gz tolerance limit, the thrust vector control system must be able to drive the seat to a stable positive pitch angle while maintaining a thrust component down the spine to counteract the large drag component up the spine. (See Figure 16.) This strategy unmodified would cause -Gz loads on the man at lower ejection airspeeds due to the smaller drag component up the spine. Such pelvis-to-head loads would require special restraint designs. Alternatively, the thrust vector control unit could be designed to move along the Z-axis prior to ejection to obtain the pitch trim angle required by the ejection circumstances.

The principle hypothesis underlying the reclined seat design strategy for escape from a maneuver loaded aircraft is that the combined properties of the thrust vector control system and seat aerostability will permit generation of a gross separation force of sufficient magnitude and proper direction to achieve separation while seat attitude is controlled to maintain the separation force vector within human tolerance limits.

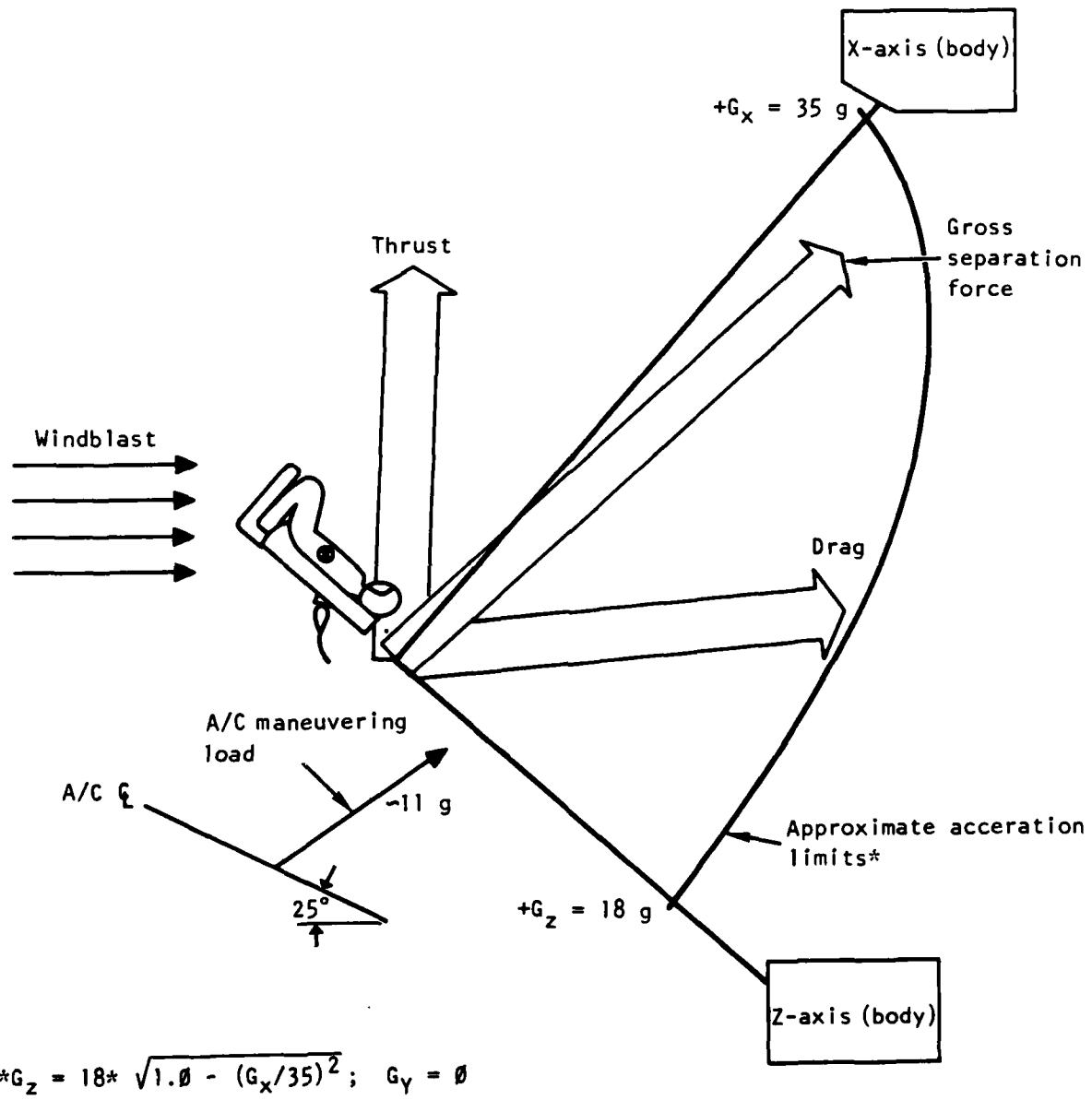

Figure 16. Reclined Seat Separation From a Maneuvering Aircraft

Verification of this hypothesis will require:

- Collection of aerostability data on the seat with rocket from wind tunnel tests
- Computer modeling of the reclined seat dynamics during escape

The following biomechanical research programs will be required to support this verification program:

- Determine the distribution of body CG within the flying population for the supine position and under appropriate dynamic loading conditions
- Conduct accelerator sled tests to measure gross body dynamic response to appropriate acceleration magnitude and directional profiles, especially restraint forces and blast shield to knee loads
- Formulate a dynamic math model of human mass response to reclined seat rotation and rocket-powered separation suitable for use with the seat dynamics computer model

#### Stabilization Response

The most critical period for reclined-seat stabilization will be during passage through the flow field generated by the aircraft. The large surface area of the bottom of the seat is likely to be exposed to a nonuniform distribution of air mass and airflows within the flow field. At high psf, this will probably generate a very large pitchup moment on the seat. (Refer to Freeman et al. (1980:p.47).) In response to this pitchup moment, the TVC system will probably aim the thrust vector as far behind the CG as possible to generate a countering pitch-down moment. The resultant of the thrust and drag forces will be at a maximum at this point because the angle between them will be minimum and their magnitudes will be close to maximum. The inertial response of the body will be large combined  $+G_x$  and  $+G_z$  loads on the surface of the back and through the spinal column/pelvis. Compared to  $-G_x$  loads, relatively little research has been done on combined  $+G_x$  and  $+G_z$  impulse loads in the context of high-speed escape. New research into tolerance to these combined loads is required, possibly drawing on data generated to support the design of the Apollo splash-down impact protection system. This crucial period also represents potential constraints on the timing of drogue chute deployment and/or the magnitude of the drogue inflation shock. Such constraints could have important implications for yaw stabilization of the seat, depending on the importance of the drogue in yaw stabilization.

The reclined seat concept includes a vertical steering control which will cause aiming of the thrust vector to the right or left of the CG to generate roll moments which will put the seat in a zero roll attitude with respect to the ground plane. There are several aspects of this rollover maneuver that would require new biomechanical research before being allowed to become part of the final design:

- Timing of the roll maneuver with respect to the crucial pitch stabilization period
- Body inertial response to roll acceleration and the accompanying lateral acceleration
- Coupling of the roll thrust deflection into the yaw axis, and the resulting maximum yaw angle and side load before counterthrusting to stop roll begins
- Concurrence of drag-induced side load and lateral thrusting during roll deceleration thrust vectoring

The earlier the roll-over maneuver occurs, the greater the rocket impulse directed toward earth and lower the minimum recovery altitude. However, if roll and pitch thrusting occur together, the thrusting will cross into the yaw axis to produce a yaw moment. Delay of the roll thrusting until pitch attitude is stabilized will reduce low-altitude recovery performance. This conflict may reduce the overall effectiveness of the reclined seat approach.

No biomechanical data are available on body responses, either gross inertial or internal stresses, to both roll and lateral accelerations under high +G<sub>x</sub> loading in a reclined posture in a high-speed escape context. Research is required to characterize these responses in this context, possibly drawing on existing data generated in support of high acceleration cockpit development.

To determine if the vertical seeking roll maneuver can be allowed to occur during pitch stabilization, research must be conducted into the effects of yaw angle on aerodynamic loading of the man and escape system. The data should be collected in both low-speed wind tunnel tests with human subjects and high-speed tests with an instrumented dummy.

The effect of combining roll and yaw deceleration moments and accompanying lateral loads with lateral drag loads due to a nonzero yaw attitude on top of a large +G<sub>x</sub> load must be studied in terms of the gross inertial responses of the body and the effect on acceleration tolerance.

## PARTIAL ENCAPSULATION

### Windblast

As shown in Table 1, the partial encapsulation concept presents many of the windblast-related energy transfer problems described for the advanced conventional seat. The primary differences are in the man to air mass and man to escape system, paths 1 and 2. The proposed partial encapsulation design is based on the hypothesis that embedding the man in a pocket of stagnated air will protect him from the adverse effects associated with direct windblast exposure. The direct man to air mass energy transfer is therefore deemphasized, while the transfers from man-to-the-escape system (through lap belt and shoulder harness), man-to-protective equipment (the torso restraint vest), and

protective equipment-to-escape system are emphasized. Verification of the stagnation hypothesis will require the following biomechanical research programs:

- Conduct a series of low-, moderate-, and high-speed wind tunnel tests to generate data on ram-pressure distributions over the body surfaces and stability of the stagnation canopy over a range of pitch and yaw attitudes
- Analyze these data and develop aerodynamic/biomechanic process descriptions which can serve as rationale for either accepting or rejecting the stagnation protection hypothesis

### Prepositioning

The partial encapsulation concept is dependent on the capability to deploy the stagnation canopy in less than 120 milliseconds and to remove it before seat/man separation. The feasibility of doing this without endangering the seat occupant must be demonstrated by a research program. This program should develop a functional mockup of the canopy deployment and release systems. Tests should then be conducted which gradually approach deployment and release at full expected speeds with human volunteer subjects. Otherwise the biomechanical research requirements for the partially encapsulated seat are the same as for the advanced conventional seat.

### Aircraft Motion

The strategy for providing separation from a maneuver-loaded aircraft is the same as described for the advanced conventional seat; i.e., make a larger total separation force sustainable by supporting the upper torso and positioning the seat in a pitch-down attitude. The provision of support for torso  $-G_x$  response will be more important on the partially encapsulated seat. The stagnation canopy will have a larger presented area and generate a larger ram pressure on the seat. A larger deceleration force will act on the seat. Therefore, the occupant's  $-G_x$  response will be greater.

### FULL ENCAPSULATION

No new biomechanical research is required for the separable forebody full encapsulation escape concept. Table 1 shows that none of the energy transfer paths between the principle mass elements will produce power levels in excess of human tolerance using current support/restraint technology. This assessment is based on passive separation of the forebody from the aircraft and aerodynamic stability of the forebody.

## BIOTECHNOLOGY PROBLEM DEFINITION

New aircraft technologies have created a requirement for extension of next generation escape system capabilities to encompass maneuver loaded aircraft and dynamic pressures to 1,600 psf. There are two classes of candidate design approaches to this requirement which also meet requirements for low bulk and light weight; the separable forebody and advanced versions of the open ejection seat. Included within the class of open seats are the advanced upright, reclined, and partially encapsulated upright seats. The two upright approaches rely to different extents on airflow stagnation to protect the seat occupant from the harmful effects of direct windblast exposure. In contrast, the reclined approach relies on an inflatable blast shield to deflect the airmass around the occupant. The separable forebody approach has inherently low separation forces because after structural severance it, in effect, falls away from a maneuvering aircraft. In contrast, all three open-seat approaches employ vertical ejection and separation. This requires that they generate very large force vectors to ensure separation from a maneuvering aircraft. Under high aircraft loads and  $Q$ , the required force magnitude exceeds the force tolerance of the spine. Therefore, all three open seat approaches require active attitude positioning to control the spinal component of the total force vector. For the upright seats, the controlled attitude is pitched down so that the occupant's major inertial response is  $-G_x$  or back to chest or into the restraint harness. For the reclined seat, the controlled attitude is pitchup so that the response is  $+G_x$  or chest to back or into the seat back. Because both reclined and upright seats expose the occupant to force magnitudes which would be injurious if aligned with the spine, they both employ strategies to maximize spine tolerance. The upright seats use an inflatable torso vest which is pulled up vertically prior to seat motion. The lifted vest supports part of the upper torso  $+G_z$  response and partially offloads the lower spine. The vest is by this support also intended to permit greater catapult forces, such as those generated by conventional catapults fired under maneuvering load conditions. The reclined seat pitched back attitude has the inertial  $+G_x$  response of the body against the seat back to hold the spine in alignment and preclude compression fracture injuries. Both the upright and reclined seats require special restraint for the pelvis. The large  $-G_x$  loads on the upright seats require the addition of crotch straps to the lap belt to preclude the pelvis slipping under the lap belt. The absence of a seat pan on the reclined seat requires crotch straps to support the pelvis against the  $+G_z$  loads caused by drag and inflation of the deceleration drogue.

The biomechanical (as opposed to engineering) feasibility or risk of the windblast and inertial load protection strategies envisioned by the upright and reclined seat approaches are not now known because empirical and analytical biomechanical data are not available. A fully informed selection of one of the four competing design approaches is not possible until such data are available. Furthermore, the characterization of the occupants biomechanical/biodynamic response to forces from the proposed support/restraint configurations and modified airflow patterns is necessary for efficient conduct of engineering research and development programs on escape system aerodynamic and thrust vector stabilization.

Therefore, development, test, and evaluation programs should be initiated immediately to acquire the required biomechanical response data. These biomechanical research programs should be completed prior to engineering development of the escape concepts because the ability to deliver the intended biomechanical protection is the performance measure for any escape system. Therefore, the biomechanical research should be designed to produce preliminary data at the earliest possible time. This implies that tests employing human subjects and functional mockups in low force wind tunnel and centrifuge tests should constitute the first testing phase. Simultaneously, there should be development of test articles suitable for testing at high impact speeds and psf levels. Also, there should be a parallel effort to expand an existing computer model of human dynamic response to include upper torso and pelvis support for  $+G_z$ ,  $-G_x$ , and  $+G_y$  by the torso vest and crotch strap/lap belt concepts. This expanded model should be developed with the preliminary load and dynamic response data from the low force centrifuge and wind tunnel tests. The model would then be available to support computer model evaluations of aerodynamic and thrust vector stabilization strategies for one of the three open-seat designs.

Table 2 summarizes the preliminary biomechanical research requirements for each of the four escape design approaches. The separable forebody approach which was this study's selection for a fully encapsulated design should require no new biomechanical research and, therefore, presents the lowest biotechnology risk. Among the three open seat approaches, the advanced upright seat presents the greatest biotechnology risk because it allows the greatest direct exposure to the wind blast. The partially encapsulated upright seat presents the next greatest risk because it requires large  $-G_x$  loads to be carried through the shoulder harness, torso vest, and pelvis restraint. The reclined open seat presents the smallest biotechnology risk of the open seats because the occupant is shielded from the windblast and the total force vector produces  $+G_x$  loads against the seat back. Note that this risk assessment excludes engineering technology risks. It is assumed that aerodynamic and thrust vector control technologies will be able to provide the attitude positioning required for simultaneous windblast protection, total force vector aiming, and separation from a maneuvering aircraft. Note that the requirement for simultaneous vertical steering, attitude positioning to align the total force vector with the X-body axis, yaw stabilization, and repositioning for decelerator inflation, represent a large technology development risk. The engineering risks for each escape design approach provide a proper larger context for the assessment of their biomechanical risks.

Table 2

SUMMARY OF BIOMECHANICAL RESEARCH PROGRAMS  
FOR FOUR ESCAPE DESIGN APPROACHES

Design approaches →	Research methods															
	Functional mockup development				Wind tunnel tests with human subjects				Impact tests with human subjects				Computer model of biomechanical response			
	AC	R	PE	FE	AC	R	PE	FE	AC	R	PE	FE	AC	R	PE	FE
<u>Protection concepts</u>																
High psf helmet/oxygen mask	•				•											
Helmet canopy	•				•				•							
Torso vest	•		•		•				•		•		•		•	
Pelvis restraint	•		•		•				•	•	•		•	•	•	
G-suit leg restraints	•		•		•		•		•		•					
Torso stagnation fences	•				•								•			
Arm restraints	•		•		•		•		•		•					
Deflector shield		•				•				•				•		
Arm restraints		•				•				•						
Leg restraints		•				•				•						
Stagnation canopy			•				•								•	
Item counts	7	3	5	0	6	3	3	0	5	4	4	0	3	2	3	0
AC - advanced conventional      PE - partially encapsulate R - reclined                              FE - fully encapsulated																

## REFERENCES

Anthony, Alastair, May 1979, Preliminary Analysis of Wind Tunnel Test of a 1/2 Scale Model of An Ejecting Crewman and Ejection Seat, AMRL-TR-78-107, Aerospace Medical Research Laboratory, Wright-Patterson Air Force Base, Ohio.

Beale, R. B., July 1975, Fluid Thrust Vector Control for the Stabilization of Man/Ejection Seat Systems, AFFDL-TR-75-105 (AD-A-021223), Air Force Flight Dynamics Laboratory, Wright-Patterson Air Force Base, Ohio.

Belk, William F., 1980, Limb Flail Inquiries and the Effect of Extremity Restraints In USAF Ejections: 1971-1978, Proceedings 17th Annual SAFE Symposium, SAFE Association, Canoga Park, California.

Burton, Russell R., Robert M. Shaffstal, and J. L. Jaggars, May 1980, Development Test and Evaluation For An Advanced Anti-G Valve for the F-15, Aviation, Space, and Environmental Medicine 51(5):504-509, Aerospace Medical Association, Washington D.C.

Cummings, Robert J., and Frank E. Drsata, June 1979, Exploratory Development of Aircrew Windblast Protection Concepts, AMRL-TR-79-45 (AD-A072013), Aerospace Medical Research Laboratory, Wright-Patterson Air Force Base, Ohio.

Cummings, Robert J., and William J. Adams, June 1980, Aircrew Windblast Protection Concepts, NA-80-390, North American Aircraft Division, Rockwell International, Los Angeles, California.

Dobbek, Richard J., 1980, Escape From Military Fighters: A Modern Perspective, Proceedings 17th Annual SAFE Symposium, SAFE Association, Canoga Park, California.

Douglas Aircraft Company, September 1978, ACES-II Advanced Concept Ejection Seat, Report MDC J4576A, McDonnell Douglas Corporation, Long Beach, California.

Freeman, Gerald A., and Gilbert R. Casteel, December 1980, Multiple Ejection Effects Analysis, AMRL-TR-80-140, Aerospace Medical Research Laboratory, Wright-Patterson Air Force Base, Ohio

Fryer, D. I., January 1962, Physiological Exposure to Ram Pressure, Aerospace Medicine 33:34-41, Medical Services, Royal Air Force.

General Dynamics, June 1980, AFTI/F-16 Development and Integration Program: Human Engineering Crew Station Design Report. 20 PR064A, Fort Worth Division, Texas.

Naval Air Development Center, May 1979, Prototype Development Passive, Seat-Mounted, Limb Retention System, NADC-79201-60 (AD-A076331), Aircraft and Crew Systems Technology Directorate, Warminster, Pennsylvania.

Grandia, M. J., G. W. Larson, W. F. Lee, and K. C. Waugh, May 1978, AFTI-16 Predesign and Preliminary Development of DFCS and HAC, Volume III: Task III - HAC Preliminary Development, AFFDL-TR-79-3016 Vol III (AD-B-041734L), Air Force Flight Dynamics Laboratory, Wright-Patterson Air Force Base, Ohio.

Grood, Edward S., Frank R. Noyes, and David L. Butler, October 1979, Knee Flail Design Limits: Background, Experimentation and Design Criteria, AMRL-TR-78-58 (AD-A-062384), Aerospace Medical Research Laboratory, Wright-Patterson Air Force Base, Ohio.

Guarracino, Jerry, Stanis Coryell, and Robert Delvecchio, October 1976, Crewman's Retention System for Protection Against High Speed Ejection Up to 600 Knots, NADC-76119-40 (AD-A036898), Crew Systems Department, Naval Air Development Center, Warminster, Pennsylvania.

Haddon, William, Jr, August 1973, Energy Damage and the Ten Countermeasure Strategies, Human Factors 15(4):355-366, The John Hopkins University Press, Baltimore, Maryland.

Harrison, William D., 1980, Aircrew Experiences in USAF Ejections, 1971-1977, Proceedings 17th Annual SAFE Symposium, SAFE Association, Canoga Park, California.

Hawker, Fred W., and Anthony J. Euler, June 1976, Wind Tunnel Studies of Vertical Acting Limb Flail Forces and Torso/Seat Back Forces In An ACES-II Ejection Seat, AMRL-TR-76-3 (AD-A029180), Aerospace Medical Research Laboratory, Wright-Patterson Air Force Base, Ohio.

Kendall, Wayne F., and Ronald C. Hill, April 1979, Biodynamic Effects of Canopy Loss in the TF-15 Aircraft, Aviation, Space, and Environmental Medicine 50(4): 338-342, Aerospace Medical Association, Washington, D.C.

Marti, V. M., and R. E. Mattes, April 1978, AFTI-15 Predesign and Preliminary Development of DFCS and HAC-Phase I Part IV Task III - Preliminary Development of HAC, AFFDL-TR-79-3017 Part IV (AD-B-035259L), Air Force Flight Dynamics Laboratory, Wright-Patterson Air Force Base, Ohio.

McDonald, A. B., August 1979, Advanced Design Aircrew Protective Restraint Systems, AMRL-TR-79-4b (AD-A076061), Aerospace Medical Research Laboratory, Wright-Patterson Air Force Base, Ohio.

Olsen, Gerner A., December 1971, The Interaction of the Components of the Human Back, Symposium on Biodynamic Models and Their Applications, AMRL-TR-71-29 (AD-739501), Aerospace Medical Research Laboratory, Wright-Patterson Air Force Base, Ohio.

Payne, Peter R., October 1965, Personal Restraint and Support System Dynamics, AMRL-TR-65-127 (AD-624487), Aerospace Medical Research Laboratories, Wright-Patterson Air Force Base, Ohio.

Payne, Peter R., May 1974, On the Avoidance of Limb Flail Injury by Ejection Seat Stabilization, AMRL-TR-74-9 (AD-783913), Aerospace Medical Research Laboratory, Wright-Patterson Air Force Base, Ohio.

Payne, Peter R., Fred W. Hawker, and Anthony J. Euler, July 1975, Stability and Limb Dislodgement Force Measurements with the F-105 and ACES-II Ejection Seats, AMRL-TR-75-8 (AD-A01523), Aerospace Medical Research Laboratory, Wright-Patterson Air Force Base, Ohio.

Peters, James M., 1980, Extension of Ejection Seat Capability for High Speed Conditions Proceedings 17th Annual SAFE Symposium, SAFE Association, Canoga Park, California.

Saab-Scania, August 1980, RS 37 Arm Restraint System, FMKA-0 I, Edengrau, Sweden

Santi, Gino P., James W. Brinkley, Charles A. Dempsey, Richard J. Dobbek, and Herman Eugel, Jr, Spring 1979, Road Map for Aircrew Escape Systems Technology, Wright Brothers Chapter Symposium, Survival and Flight Equipment Association, Wright-Patterson Air Force Base, Ohio.

Schneck, Daniel J., March 1980, Studies of Limb Dislodging Forces Acting on an Ejection Seat Occupant, Aviation, Space, and Environmental Medicine 51(3):256-264, Aerospace Medical Association, Washington D.C.

Schwartz, Marcus, April 1979, Feasibility Testing of a Body Inflation Bladder (BIB) Restraint Device, NADC-79241-60 (AD-A078681), Aircraft and Crew Systems Technology Directorate, Naval Air Development Center, Pennsylvania.

Sears, William J., J. Erasting, R. Krutz, R. Shaffstall, and R. Holden, 1980, An Improved Oxygen Mask for High-Altitude Protection, Proceedings 17th Annual SAFE Symposium, SAFE Association, Canoga Park, California.

Shaffstall, Robert M., Russell R. Burton, August 1979, Evolution of Assisted Positive-Pressure Breathing on +G<sub>y</sub> Tolerance, Aviation, Space, and Environmental Medicine 50(8):820-824, Aerospace Medical Association, Washington D.C.

Stapp, John P., and C. D. Hughes, October 1956, Effects of Mechanical Force on Living Tissues, II, Supersonic Deceleration and Windblast, Journal of Aviation Medicine 27:407, Aerospace Medical Association, Washington, D.C.

Swanson, Douglas E., August 1978, Crew Escape for High Performance Aircraft, AFFDL-TR-78-56 (AD-A060519), Air Force Flight Dynamics Laboratory, Wright-Patterson Air Force Base, Ohio.

Tauby, William C., James P. Murry, Leonard H. Wright, and James Martin, September 1979, Investigation of Minimum Sized Low-Profile Cockpits (MSLPC) and Crew Escape System Integration, AFFDL-TR-79-3104 (AD-A-081055), Air Force Flight Dynamics Laboratory, Wright-Patterson Air Force Base, Ohio.

Tyburski, John J., George D. Frish, and Louis A. D'Auleino, 1980, Low Level, Adverse Attitude Escape Using a Vertical Seeking Ejection Seat, Proceedings 17th Annual SAFE Symposium, SAFE Association, Canoga Park, California.

Walker, Harley R., Stephen R. Mehaffie, August 1977, Problems and Technical Voids in Emergency Crew Escape, AFFDL-TR-77-75 (AD-8-024869L), Air Force Flight Dynamics Laboratory, Wright-Patterson Air Force Base, Ohio.

White, Clayton S., Robert K. Jones, Edward G. Damon, E. Royce, Fletcher, and Donald R. Richmond, December 1971, The Biodynamics of Airblast, Conference on Linear Acceleration of Impact Type, (AD-737090), AGARD-CP-88-71, Advisory Group for Aerospace Research and Development, North Atlantic Treaty Organization, France

Woodward, Clifford C., and Marcus Schwartz, 1980, High "Q" Ejection Protection Device, Proceedings 17th Annual SAFE Symposium, SAFE Association, Canoga Park, California.

**BLANK PAGE**

**DATE**  
**ILME**