

MICROCOPY RESOLUTION TEST CHART
ANSI #2 - 1983

12

AD A117563

DRXTH-TE-



AD _____

ENGINEERING AND DEVELOPMENT SUPPORT OF GENERAL
DECON TECHNOLOGY FOR THE U.S. ARMY
INSTALLATION RESTORATION PROGRAM

Task 1. Literature Review on Landfill or Lagoon Bottom Sealing

Judith F. Kitchens

ATLANTIC RESEARCH CORPORATION
5390 Cherokee Avenue
Alexandria, Virginia 22314

February, 1982

Prepared for:

Commander
U.S. Army Toxic and Hazardous Materials Agency
Aberdeen Proving Ground, Maryland 21010

DTIC
SELECTED
JUL 28 1982
H

DTIC FILE COPY

Approved for Public Release
Distribution Unlimited

ATLANTIC RESEARCH CORPORATION
ALEXANDRIA, VIRGINIA • 22314

82 07 28 011

Disclaimer

The views, opinions and/or findings contained in this report are those of the authors and should not be construed as an official Department of the Army position, policy or decision unless so designated by other documentation.

Disposition

Destroy this report when it is no longer needed. Do not return it to the originator.

UNCLASSIFIED

SECURITY CLASSIFICATION OF THIS PAGE (When Data Entered)

REPORT DOCUMENTATION PAGE		READ INSTRUCTIONS BEFORE COMPLETING FORM
1. REPORT NUMBER	2. GOVT ACCESSION NO.	3. RECIPIENT'S CATALOG NUMBER
	ADA117 563	
4. TITLE (and Subtitle) Engineering and Development Support of General Decon Technology for the U.S. Army Installation Restoration Program. Task I. Literature Review on Landfill or Lagoon Bottom Sealing		5. TYPE OF REPORT & PERIOD COVERED Final Report June - November 1980
		6. PERFORMING ORG. REPORT NUMBER 49-5002-01C-0001
7. AUTHOR(s) Judith F. Kitchens		8. CONTRACT OR GRANT NUMBER(s) DAAK11-80-C-0027
9. PERFORMING ORGANIZATION NAME AND ADDRESS Atlantic Research Corporation 5390 Cherokee Avenue Alexandria, Virginia 22314		10. PROGRAM ELEMENT PROJECT, TASK AREA & WORK UNIT NUMBERS
11. CONTROLLING OFFICE NAME AND ADDRESS DCASR Philadelphia P.O. Box 7730 Philadelphia, Pennsylvania 19101		12. REPORT DATE February, 1982
		13. NUMBER OF PAGES 61
14. MONITORING AGENCY NAME & ADDRESS (if different from Controlling Office) U.S. Army Toxic and Hazardous Materials Agency Aberdeen Proving Ground Maryland 21010		15. SECURITY CLASS. (of this report) Unclassified
		15a. DECLASSIFICATION DOWNGRADING SCHEDULE
16. DISTRIBUTION STATEMENT (of this Report) Approved for public release, distribution unlimited		
17. DISTRIBUTION STATEMENT (of the abstract entered in Block 20, if different from Report)		
18. SUPPLEMENTARY NOTES Contract Project Officer: Mr. Michael Asselin (DRXTH-TE-D)		
19. KEY WORDS (Continue on reverse side if necessary and identify by block number) lagoons hydraulic fracturing synthetic liners landfills hydrofracing bottom sealing horizontal drilling grouting pancake slurry jetting directional drilling floating a liner		
20. ABSTRACT (Continue on reverse side if necessary and identify by block number) This report presents a review and evaluation of the available information on techniques for bottom sealing an existing lagoon or landfill. Several bottom sealing techniques were evaluated including grouting with directional drilling, directionally controlled horizontal drilling and vertical drilling; hydraulic fracturing and grouting; pancake slurry jetting; floating a bentonite liner; and floating a synthetic liner. The advantages and limitations of each method and costs are presented for application of each technique to a standard lagoon scenario.		

SUMMARY

The purpose of this study was to evaluate the technical feasibility, costs and problems associated with placing a bottom seal underneath an existing landfill or lagoon. Six techniques were evaluated: 1) directional drilling with grouting, 2) directionally-controlled horizontal drilling with grouting, 3) vertical drilling with grouting or pancake slurry jetting, 4) hydraulic fracturing, 5) floating a bentonite or synthetic liner and 6) deep chemical mixing. All of these techniques were compared on the basis of bottom sealing a 30.5 m x 47.5 m x 2.7 m deep lagoon.

Only two of the techniques, floating a bentonite liner and deep chemical mixing for lagoon bottom sealing have ever been tried. These techniques are relatively inexpensive if compatible with the waste materials. Hydraulic fracturing and vertical drilling have high technical risks associated with them due to the potential for high level contamination of the ground water. Directionally-controlled horizontal drilling has potential for waste site bottom sealing. If this technique can be combined with pancake slurry jetting, the problems associated with the grouting operation could be overcome. However, field testing must be performed before this technique can be applied to a waste site.



Accession For	
NTIS GPOSI	<input checked="" type="checkbox"/>
DTIC TAB	<input type="checkbox"/>
Unannounced	<input type="checkbox"/>
Justification	<input type="checkbox"/>
By _____	
Distribution/	
Availability Codes	
Dist	Avail and/or Special
	<input type="checkbox"/>
	<input type="checkbox"/>

TABLE OF CONTENTS

	<u>Page</u>
I. Introduction	9
A. Objective	9
B. Background	9
C. Standard Lagoon.	9
II. Bottom Sealing of an Existing Lagoon or Landfill via Directional, Horizontal or Directionally-Controlled Horizontal Drilling	12
A. Background	12
B. Directional Drilling and Directionally-Controlled Horizontal Drilling Technology	14
1. Deflection Tools	14
2. Down-Hole Drilling Motors	16
3. Directional Measurements	20
C. Problems Associated with the Current State-of-the-Art in Directional or Directionally-Controlled Horizontal Drilling.	20
D. Past Applications of Directional and Directionally-Controlled Horizontal Drilling	22
E. Application of Directional and Directionally-Controlled Horizontal Drilling to Lagoon Bottom Sealing	25
1. Directional Drilling	25
2. Directionally-Controlled Horizontal Drilling	25
a. Optimizing Drilling Paths	25
b. Selection of the Drilling Mud.	31
c. Grouting of the Hole	32
F. Costs for Grouting a Lagoon Bottom via Directionally- Controlled Horizontal Drilling.	33
III. Bottom Sealing an Existing Lagoon or Landfill via Vertically Drilling Through the Site	35
A. Background	35
B. Application of Vertical Grouting to Bottom Sealing an Existing Lagoon or Landfill.	35
C. Application of "Pancake Slurry Jetting" to Bottom Sealing an Existing Lagoon or Landfill	36

	D. Problems Associated with Vertically Placed Bottom Seals	40
	E. Economics of Bottom Sealing via Vertical Drilling Through the Site	40
IV.	Hydraulic Fracturing for Bottom Sealing an Existing Lagoon or Landfill	45
	A. Background	45
	B. Application of Hydraulic Fracturing to Bottom Sealing an Existing Lagoon or Landfill.	45
	1. Factors Affecting Hydrofracing	45
	2. Preplanning	48
	3. Hydrofracing - BJ Hughes Concept.	48
	4. Hydrofracing - Concept of Huck, Waller and Shimondle	48
	5. Determining the Fracture Area	48
	C. Problems Associated with Hydrofracing Under a Waste Site	51
	D. Economics of Hydrofracing for Bottom Sealing a Standard Lagoon	51
V.	Deep Chemical Mixing (DCM)	54
	A. Background	54
	B. Application of DCM to Bottom Sealing a Lagoon.	54
VI.	Floating a Liner	56
VII.	Conclusions and Recommendations	57
VIII.	References.	60

LIST OF TABLES

<u>Number</u>		<u>Page</u>
I.	Characteristics of a Standard Lagoon	10
II.	Available Directional Guidance Equipment	21
III.	Horizontal and Vertical Drill Distances for Various Build-up Angles.	30
IV.	Costs Associated with Bottom Sealing a Standard Lagoon via Directionally-Controlled Horizontal Drilling	34
V.	Costs for Bottom Sealing an Existing Lagoon via Vertical Drilling	43
VI.	Costs for Bottom Sealing a Lagoon via Hydraulic Fracturing	53
VII.	Summary of Methods for Bottom Sealing a Lagoon or Landfill.	58

LIST OF FIGURES

<u>Number</u>		<u>Page</u>
1.	Subsurface Characteristics of Standard Lagoon	11
2a.	Bottom Sealing of a Lagoon via Directional Drilling.	13
2b.	Bottom Sealing of a Lagoon via Horizontal Drilling	13
2c.	Bottom Sealing of a Lagoon via Directionally-Controlled Horizontal Drilling	13
3.	Bit Deviation by Whipstock	15
4a.	Bit Deviation with a Bent-sub and Down-hole Motor	15
4b.	Dyna-Drill Tool Assembly Showing Bent-Housing and Standoff Ring	15
5.	Directional Jetting Bit	17
6.	Advanced Directional Turbodrill	18
7.	Dyna-Drill	18
8.	Dyna-Flex® Hydraulically Actuated Bent-sub	23
9.	Titan Contractor's Big Alice Drill Rig	24
10.	Drilling Pattern for Bottom Sealing the Standard Lagoon.	26
11.	Geometry of the Directionally-Controlled Horizontal Drilling Operation Under the Standard Lagoon	28
12.	Radius of Curvature vs Build-Angle for Directionally-Controlled Horizontal Drilling	29
13.	Cross Section of Grouted Bottom Seal Beneath a Landfill	37

14.	High Pressure Fluid Jetting	38
15.	Procedure for "Pancake Jetting " to Place an Impermeable Floor Under a Waste Site	39
16.	Grid Pattern for Bottom sealing via Vertical Drilling	41
17.	Principal Stress Planes	46
18.	BJ Hughes Concept for Hydrofracing under a Lagoon	49
19.	Controlled Hydraulic Fracture to Place an Impermeable Floor Beneath a Waste Site.	50
20.	Deep Chemical Mixer Mounted on Barge	55

I. INTRODUCTION

A. Objective

The objective of this report is to review and evaluate techniques for bottom sealing an existing lagoon or landfill to prevent contamination of the ground water by the leachates. The applicable techniques considered in this report are: 1) bottom grouting via directional drilling, horizontal drilling and directionally-controlled horizontal drilling, 2) bottom grouting via drilling through the lagoon or landfill, 3) bottom grouting via hydraulic fracturing, 4) deep chemical mixing and 5) floating a liner. These techniques are compared technically and for cost effectiveness with methods which surround the landfill or lagoon with a hydraulic barrier or a barrier wall keyed into an impervious subsurface layer, *i.e.* slurry-trenches, grout curtains, Imper-wall, or sheet pilings. The technical evaluation of barrier methods was presented in an earlier report (Sommerer and Kitchens, 1982) and will not be repeated herein.

B. Background

The Army has been in the explosives manufacturing and loading business since the 1930's. During this time, the Army has operated Ammunition Plants located throughout the United States. These operations have resulted in the generation of significant amounts of solid and liquid wastes. In the years before 1970, these wastes were discharged into surface waterways and landfilled or lagooned. Many of these landfills and lagoons were located in soils of high permeability and were unlined. Over the years, the chemical wastes from the improperly constructed lagoons and landfills have gradually leached toward, and in some instances, into the ground water.

The Army is currently developing techniques for decontamination of improperly constructed lagoons and landfills. However, it is desirable to seal these lagoons and landfills to prevent further subsurface contamination of ground water until treatment technologies are developed.

C. Standard Lagoon

Selection of a technique to bottom seal an existing lagoon or landfill must be based on technical and cost considerations. It is thus desirable to be able to compare technical and cost advantages and disadvantages of the different methods on a standard site, such as a lagoon. The standard lagoon chosen for the comparison has the characteristics listed in Table I. The subsurface characteristics under the lagoon are shown in Figure 1. This standard lagoon is identical with that in the parallel task to evaluate treatment technologies for explosives containing sediments. Thus, the costs for barrier construction can be directly compared with treatment costs (Wentsel *et al.*, 1982).

Table I. Characteristics of a Standard Lagoon

Size:	30.5 m x 45.7 m x 2.4 m deep		
Depth of Sediment:	0.30 m		
Explosives Concentration in Sediment:	10% TNT		
	5% RDX		
	100 µg/g DNT		
	100 µg/g Tetryl		
Bottom Area to be Sealed:	1420 m ²		
Subsurface Features:	depth, m	soil types	
	0-5.5	clay-sand	8.55-11.5
			silty-sand
	5.5-8.5	plastic-clay	0.34
			207
			7.62
Depth of Impervious Subsurface Layer:	18.3 m		

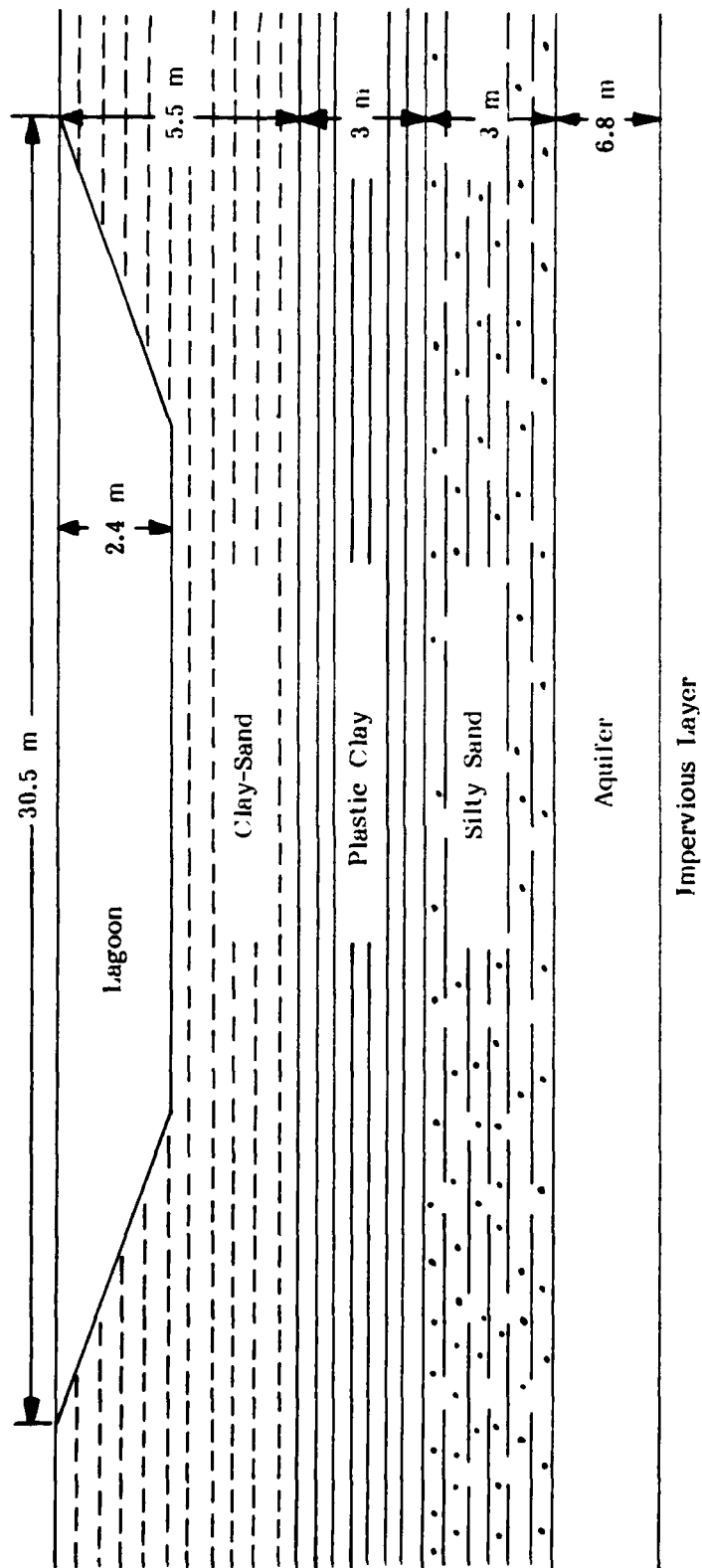

Figure 1. Subsurface Characteristics of Standard Lagoon

II. BOTTOM SEALING OF AN EXISTING LAGOON OR LANDFILL VIA DIRECTIONAL, HORIZONTAL OR DIRECTIONALLY- CONTROLLED HORIZONTAL DRILLING

A. Background

Bottom sealing of an existing lagoon or landfill can potentially be accomplished by grouting of directionally drilled, horizontally drilled or directionally-controlled horizontally drilled holes. These holes are drilled from the ground surface outside the lagoon or landfill as shown in Figure 2a-c. Thus, no interaction occurs between the drilling operation and the wastes. The integrity of the landfill or lagoon bottom is also preserved.

In general, directional drilling is defined as "the art of controlling a rotary drill's directional and angular tendencies while penetrating the earth's surface" (Bak, 1978). In this report, we will adhere to the following definitions to distinguish between directional drilling, horizontal drilling and directionally-controlled horizontal drilling.

- Directional drilling will be used to refer to a vertical entry hole which has been intentionally deviated from the vertical by directional control of the drill bit. This drilling approach is shown in Figure 2a.
- In the horizontal drilling approach, shown in Figure 2b, the drill penetrates the earth's surface at an inclination angle of $<90^\circ$. This technique does not employ any means of changing the direction of the bit or directional control.
- In directionally-controlled horizontal drilling, the drill penetrates the earth's surface at an angle of inclination of $<90^\circ$. However, directional control of the bit is used to place the hole along the desired path. Bottom-sealing using this drilling technique is illustrated in Figure 2c or 2b.

Horizontal drilling without directional control is not a viable method for bottom sealing an existing lagoon or landfill. Bottom sealing of a lagoon or landfill depends on accurate spacing of the grout holes to ensure that the bottom is completely sealed. Vertical control to ensure that the drill does not penetrate the site is also necessary. This degree of accuracy cannot be obtained with non-directionally-controlled equipment. Thus, the following discussion will be limited to directional drilling and directionally-controlled horizontal drilling.



Figure 2a. Bottom Sealing of a Lagoon via Directional Drilling

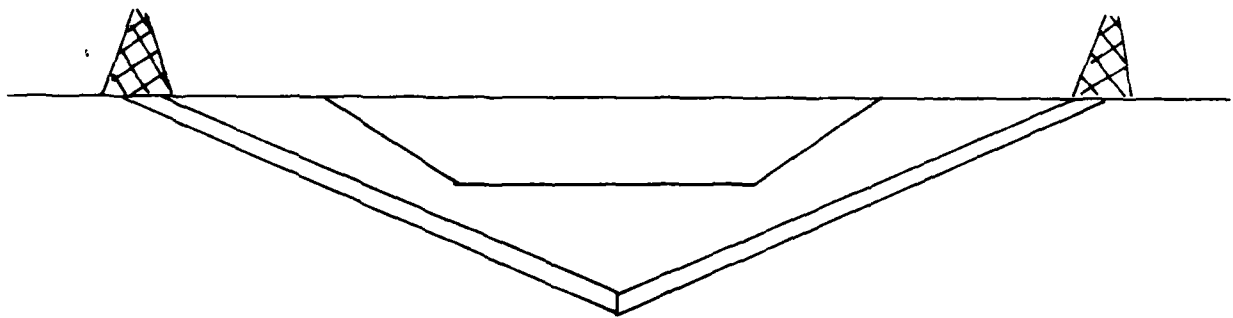

Figure 2b. Bottom Sealing of a Lagoon via Horizontal Drilling

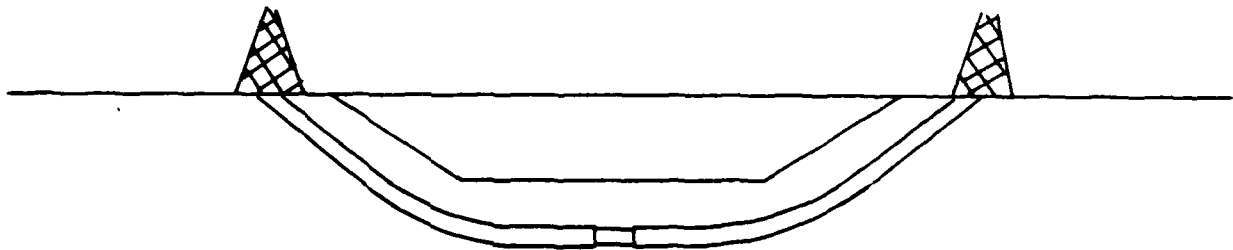

Figure 2c. Bottom Sealing of a Lagoon via Directionally -
Controlled Horizontal Drilling

B. Directional Drilling and Directionally-Controlled Horizontal Drilling Technology

Directional drilling was first demonstrated in 1934 by H. John Eastman and The Humble Petroleum Company. They used mechanical deflectors to drill a new well within a 30.5 m radius of a runaway oil well in order to kill the wild well (Thompson, 1979). The procedure was successful and the wild well was killed.

Further development in directional control of the course of the drill bit was not undertaken until the 1950's. During the thirty year period from 1950 to the present, major advances in drill motors, directional control methods, guidance techniques and drill rigs occurred in both the non-Communist world and in Russia. The technology of controlled deviation and drilling of a well can be divided into three components:

- deflection tools
- drilling motor
- directional measurements.

1. Deflection Tools

Several types of tools are available which can be used to deliberately deviate a hole 1) whipstocks, 2) bent-subs, and 3) jet bits. Hole deviation control is also a function of the weight and configuration of the down-hole assembly and the weight of the bit. Thus, these factors must also be taken into consideration when planning a deviated hole.

The oldest technique used to deviate a drill bit is the whipstock method. A whipstock is essentially a long concave steel wedge. As shown in Figure 3, this wedge creates a curvature in the bit path by holding and guiding the drill assembly. Whipstocks have the advantage of providing initial controlled hole curvature. The side forces of the drill assembly are distributed over the entire length of the whipstock. However, problems can arise in control of the curvature in soft formations if the side forces against the whipstock become negative. In general, whipstocks can be used in any type of formation (Millheim, 1979). Whipstock does have one major disadvantage which increases their costs compared to other hole deviation tools, i.e. the initial hole must be drilled with a small bit. Thus, several trips must be made to obtain a hole of the desired bore (Millheim, 1979; McDonald et al., 1979).

Another technique used to deviate a bit is a bent-sub or bent housing. This deviation technique is always used with a down-hole motor. As shown in Figure 4, the bend serves to produce a side force on the bit which deviates the bit in the direction of the bent-sub facing. A standoff ring (Figure 4b) may also be added to the bent-sub to create greater bit deviations. Bent-sub with down-hole motors are the preferred method of directional drilling. Bent-sub directional control is difficult

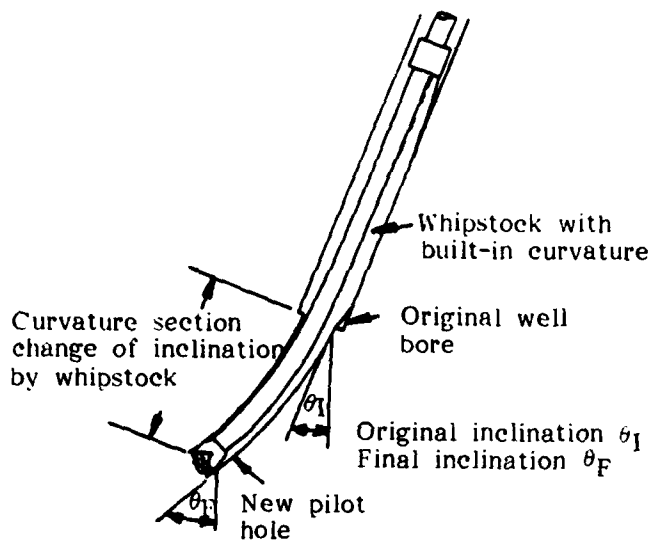

Figure 3. Bit Deviation by Whipstock (Millheim, 1979)

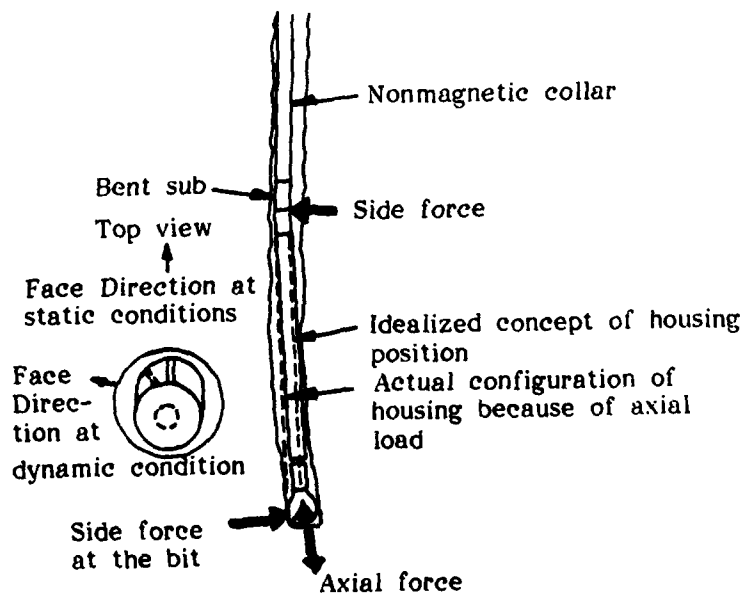

Figure 4a. Bit Deviation with a Bent-sub and Down-hole motor (Millheim, 1979)

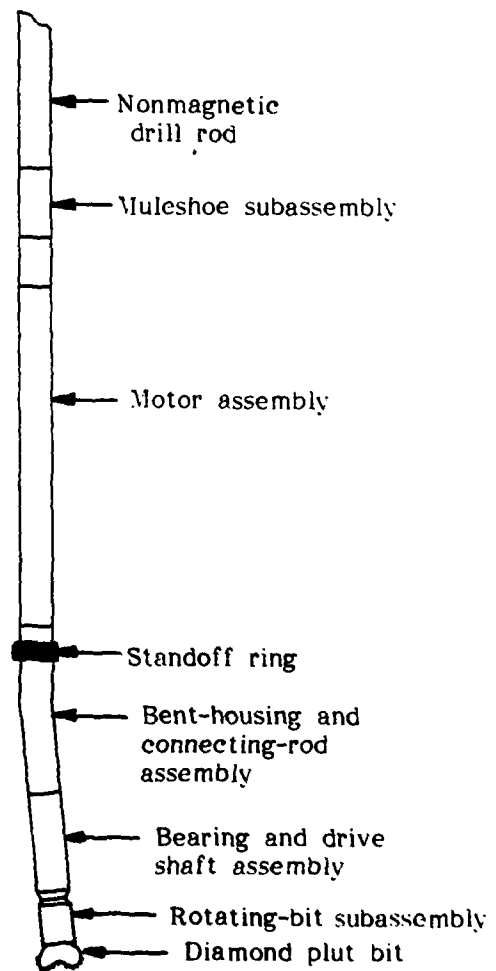

Figure 4b. Dyna-Drill Tool Assembly Showing Bent-Housing and Standoff Ring (Diamond et al., 1977)

in very soft formations because these formations cannot sustain the high side forces generated (Millheim, 1979). The degree of deviation of the hole is not totally relatable to the degree of bending of the sub since each down-hole motor generates its own bending characteristics. Thus, each bent-sub down-hole motor combination will have its own bending characteristics in various subsurface formations.

A jetting bit, similar to that shown in Figure 5, can also be used to deviate the trajectory of a bore. Directional control is obtained by orienting the large jet in the direction of the desired trajectory change and pumping water or mud through the jet. This method of directional control is very approximate and may require several attempts to obtain the desired trajectory. However, the method is inexpensive. The drill used for the directional control may also be used to drill ahead. Jetting is only applicable in medium soft formations (Millheim, 1979). Very soft formations tend to erode while hard formations are not sufficiently eroded by the water or mud stream.

2. Down-Hole Drilling Motors

As discussed above, the bent-sub with the down-hole motor is the preferred directional drilling assembly. Three basic types of down-hole motors have been developed for use with a bent-sub for directional drilling:

- turbodrills
- positive displacement mud motors
- electrodrills

Turbodrills are hydraulic powered motors which utilize axial flow turbine blade sections to apply torque to the drill bit. The torque and the horsepower output of these motors is determined by the fluid velocity or pressure loss across the turbine. Maximum torque is obtained when the turbine stalls. High rotary speeds result in low torque. The torque on the drill bit may be increased by increasing the number of turbine stages and the turbine blade exit angle. Increased fluid flow rate will also increase the torque (Maurer *et al.*, 1978). A bearing pack and a rotating bit sub are located below the turbine sections as shown in Figure 6.

Turbodrills are popular in Russia, the Middle East and Europe for both straight and directional drilling. It is estimated that 60-70% of the wells drilled in Russia are drilled with turbodrills (McDonald *et al.*, 1979). These drills have several disadvantages which have limited their use in the United States. These limitations include high rotary speeds (300-1000 rpm), low torque and low horsepower output, low bit pressure drops, long motor length, excessive weight, short bearing life and tendencies toward bending (McDonald *et al.*, 1979; Dowding, 1976). The high rotary speeds of the turbodrills cause excessive wear and tear on both crew and equipment resulting in high overall drilling costs (Garrison, 1975). These motors also tend to stall in soft sticky clay which limits their use in this type of formation.

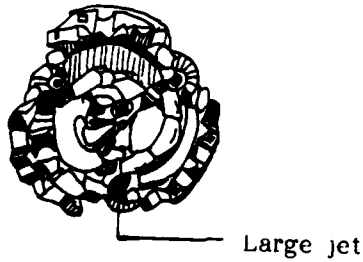

a. Bit

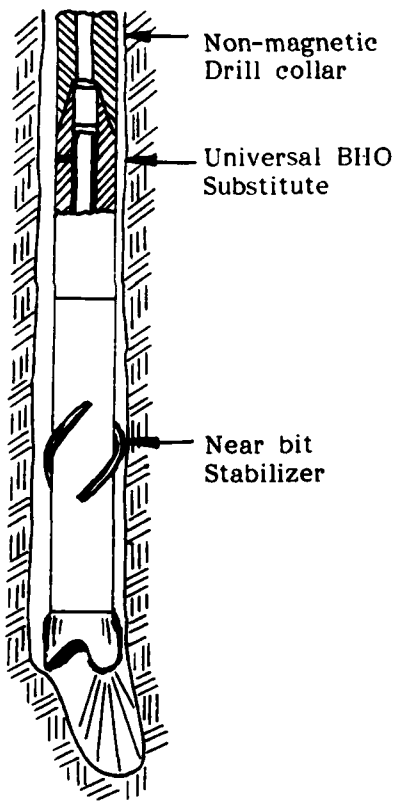

b. Curvature
Initiation

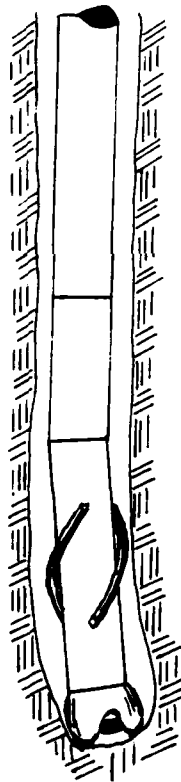

c. Controlled
Curvature

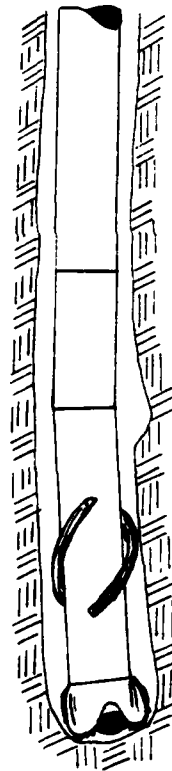

d. Realignment
After Failure to
Obtain Desired
Trajectory

Figure 5. Directional Jetting Bit (McDonald et al., 1979)

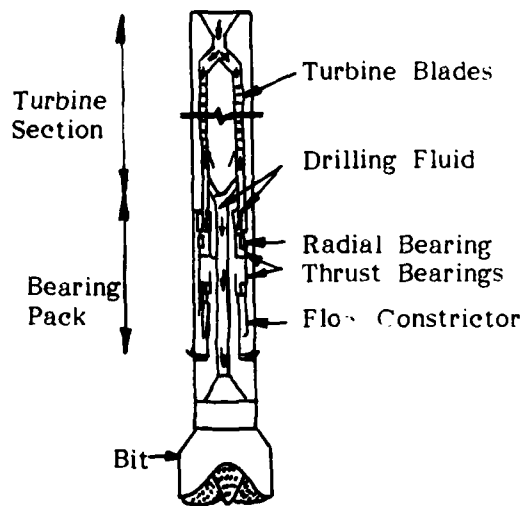

Figure 6. Advanced Directional Turbodrill (Maurer *et al.*, 1978)

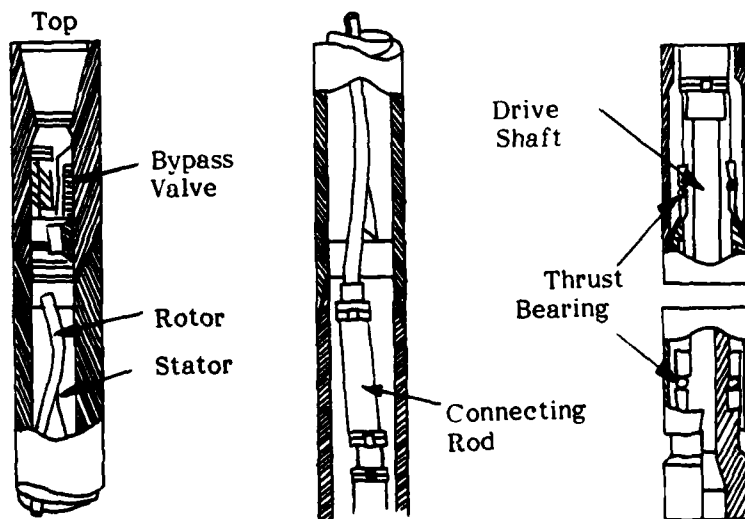

Figure 7. Dyna-Drill (McDonald *et al.*, 1979)

Many improvements in turbodrills are currently underway to adapt them to modern drilling needs. However, the current state-of-the-art turbodrills would not be applicable to directional drilling or directionally-controlled horizontal drilling under landfills or lagoons.

The only positive-displacement down-hole motor in current use is the Dyna-drill. This motor is basically a reverse Moyno pump. The long cylindrical sinusoidally shaped solid steel rotor is housed in an obround, spiral stator as shown in Figure 7. The rotor is free at the upper end with the bottom end attached to a connecting rod. This connecting rod converts the eccentric motion of the rotor into the concentric motion necessary to turn the drive shaft and bit (Dowding, 1976). The bit is the only external moving part. The motor assembly does not turn, thus, a bent-housing can be used for directional control. To operate the motor, the drilling fluid is forced down the spiral path between the rotor and stator. The positive displacement motor has several operational advantages including:

1. The flow rate provides the operator with a direct measure of the rotary speed of the bit since the rotary speed is directly proportional to the pump flow rate (Mauer *et al.*, 1978).

2. The torque output and hydraulic horsepower are a function of the pressure loss through the motor, thus, the rig mud pressure gauge can be used to monitor torque (Maurer *et al.*, 1978).

3. For drilling in soft formations, the Dyna-drill is optimal due to its light weight, maneuverability and low fluid requirements (Dowding, 1976).

Electric down-hole motors, electrodrills, have been developed, built and tested in the United States, however, they have not been used in commercial drilling operations. One such motor was assembled by CONOCO. This motor consisted of an ordinary submersible pump made by Century Electric Motor Company coupled to a planetary type gear box designed by Reda Pump Company (Dowding, 1976). Another motor, the Electrodrill is made by the General Electric Company. Directional drilling has been demonstrated with this motor (General Electric Company, Space Division, 1977).

The Russians have three types of electrodrills which have been used in the oil field - an Arutunoff tool, a pipeless electrodrill and an electrodrill on a pipe. These motors have power and speed ranges which are beyond most rotary drills (Garrison, 1975).

Stalling of electrodrills in soft sticky clays or during hole deviation can be a significant problem. If the motor does not have quick trip overload protectors, it can short out before the crew can respond to the stall condition. Electrical shorts can also develop from water leakage. This type of motor also requires constant cooling with drilling fluid to prevent motor overheating (Dowding, 1976).

3. Directional Measurements

Directional guidance for directional and directionally-controlled horizontal drilling is usually accomplished by halting the drilling operation and lowering the survey equipment down the hole through the drill string. The inclination is measured by means of an accelerometer (pendulum). A magnetic compass, gyro or gyrocompass can be used to determine azimuth. If a magnetic compass is used, it is necessary to employ a non-magnetic stainless steel drill rod immediately above the motor. The magnetic compass is also affected by magnetic anomalies in the subsurface around the drill area. The readings of these instruments are usually recorded on time activated single or multishot cameras. After the picture(s) is taken, the survey package is removed from the drill string, the film developed, and the position calculated. Several packaged programs for hand calculators are available to perform these calculations (Brown, 1980). This procedure is time consuming especially if surveys are necessary every 3 m. To overcome this problem, systems have been developed which use electronic sensors and cable data transmission to provide the readout. "Measurement while drilling" systems are also being developed. A summary of the available directional guidance equipment is presented in Table II.

C. Problems Associated with the Current State-of-the-Art Directional or Directionally-Controlled Horizontal Drilling

Even though down-hole motors with bent-housing or bent-subs have significant money and time savings advantages over whipstocking, directional and directionally-controlled horizontal drilling is still very much an art and not a science. The accuracy in placement of the hole is highly dependent on the skill of the drill rig operator (McDonald *et al.*, 1979; Emory, 1980; Garrett, 1980). Other problems encountered in these types of drilling operations are:

- the excessive time required for survey measurements
- the excessive number of trips in and out of the hole to change the sub angle
- difficulty in controlling the direction of the bit
- danger of the bit dragging into the wall during tripping in and out of the hole
- inability to totally control the bit direction from the surface
- low build-up angle limitations

Several manufacturers and well drillers have undertaken programs aimed at eliminating these problems. As discussed in the previous sections, "measurement while drilling" systems are being developed. A remotely actuated kick sub has also been developed for the Dyna-Drill (Harding *et al.*, 1976). This kick-sub, shown in

Table II. Available Directional Guidance Equipment (Dowding, 1976)

Name and Company	Mechanization	Dimensions	Power Requirements	Angle Limits	Depth Limit	Temperature Limit	Pressure Limit	Resolution and Accuracy	Cable Requirements
Gyrosurveyor (Hampshire (Horizontal Surveyor))	Directional Gyro Pendulum With Potentiometer	1.38" Dia.	28V DC From 115V 60Hz Supply	+60° Incl. -745° AZIMUTH	1500 Ft (1000 Ft Dist. to Date)	250-300°F	15K PSI with 3/8" Case	Res. 10° INCL. Acc. 1° INCL. GYRO DRIFT 4-6°/hr Good Printout	DC Voltages, Scanned Digital Display Printout
Swivel Sperry-Sun	Gyrocompass, Pendulum	1-3/4" and 3" Dia.	Self- Cont. D Cells 30V	0-25° to 0-90° INCL. 360° AZIMUTH	23K Ft	-	-	Res 5° INCL. ACC 6"/100 Ft. Gyro Drift 1-3°/hr GOOD	Photo- Single Shot
Magnetic Multishot Sperry-Sun	Magnetic Compass, Pendulum	1-1/4" Dia and 1-3/4" D Shield	Self- Cont. D Cells 8-WV	0-25° To 0-120° INCL. 360° AZIMUTH	-	600° for 5 hours	-	Res 5° INCL. Acc. 1/2" Best for AZIMUTH	Photo- Multishot
Single Shot Sperry-Sun	Magnetic Compass, Pendulum	<1-3/4" Dia.	Self- Cont. D Cells 8-WV	-	>20K Ft.	400°F	-	-	Photo- Single Shot
Eye Scientific Drilling Controls	3 Axis Magnetometers 3 Axis Accelerometers	1-3/4" Dia.	DC Voltage	0-90° INCL. 360° AZIMUTH	16 K Ft.	>300°F	20K PSI	Res. 10° INCL. .01° AZIMUTH .01°/100° DOG LEG .01 Ft	Printout Incl., AZ., Depths (2) Latitude, E-W Depart. Dog Leg Sev
TELEDRIFT Byar-Drill	Pendulum Acoustic Pulse Output	5" Dia.	None	10-1/2° INCL. 3-1/2" Range	22K Ft.	-	-	Res 1/2°	Acoustic Pulses 1 per 1/2° In
Teleorienter Byar-Drill	Rotating Counterweight Acoustic Pulse Output	5" Dia	None	360° AZIMUTH	22K Ft.	-	-	Res 20-90°	Acoustic Pulses Tool Bit Wrt to side
Gyroscopic Multishot Eastman	Directional Gyro Pendulum	3 1/8" Dia.	Self- Cont. D Cells 3V	0-120° to 0-750° INCL. 360° AZIMUTH	12K- 26K Ft.	300°F for 3 hours	-	Res 1/4° INCL. (interp to 5°) GYRO DRIFT <6°/hr	Photo

Figure 8, allows the motor to be lowered or removed from the hole in a straight configuration. Once in place, the bend-angle can be initiated and changed over the range of $1/2$ to 2° . This change is activated from the surface by dropping a locking probe down the drill string (Harding *et al.*, 1976). However, this kick-sub cannot be currently used in horizontal directionally-controlled drilling.

Remote steering from the surface would greatly improve the accuracy and costs of directional and horizontally-controlled directional drilling. The Russians are reported to have a surface steerable down-hole electric motor (C&E News, 1979). No detailed information on the steering mechanism is available in the literature and the persons reported to have knowledge of it are not willing to disclose their knowledge. Continental Oil Company is also reportedly developing a horizontal drilling technique which uses a down-hole motor, down-hole thruster and a steering shoe which is remotely actuated (Harding *et al.*, 1976).

Currently, directional deviation is limited to approximately $5^\circ/30$ m. Above this angle build-up, several problems arise including loss of bit thrust, excessive wear on the casing, difficulty in retracting the drill string, fatigue in the drill pipe, necessity for limber drill strings making bit control difficult and problems with the survey instruments (McDonald *et al.*, 1979). Thus, current technology allows relatively accurate, problem-free directional drilling for holes like those shown in Figure 2a or 2c. Higher deviated holes, similar to that shown in Figure 2a, are extremely difficult or impossible to drilling using current state-of-the-art equipment.

D. Past Applications of Directional and Directionally-Controlled Horizontal Drilling

The main application of directional drilling has been in the oil industry. Directional drilling is used for a variety of purposes in this industry including drilling of directional wells from the same off-shore platform, branching of wells from the same bore hole, relief holes to kill wild wells, etc. (McDonald *et al.*, 1979). The literature contains many case histories of directional oil well drilling (Thompson, 1979 and others). Directional drilling of geothermal wells is also being explored (Pettitt, 1977; Maurer *et al.*, 1978). Sandia Laboratory is managing a Drilling and Completion Technology Development Program for the Department of Energy. This program is exploring advanced drilling techniques, including directional drilling, and their application to geothermal wells (Barnett, 1979; Varnado and Stoller, 1978). Applications of directional drilling to underground coal gasification and oil shale retarding have been investigated both theoretically and in the field (Stephens, 1979; Oyler *et al.*, 1979; Diamond *et al.*, 1977). Each of these applications has its own specific requirements for directional drilling, thus, the tools which work well in one situation may not be applicable to a different directional drilling problem.

Directionally-controlled horizontal drilling has been extensively developed in the United States by Titan Contractors Corporation (now owned by Reading and Bates Construction Company). This firm has developed horizontal drilling rigs especially adapted to directionally-controlled horizontal drilling under water. Titan's large rig, Big Alice, is shown in Figure 9. A smaller rig is also available. A Dyna-Drill is used for directional control to drill the initial line. Larger cutting heads can be used to follow-up after the Dyna-Drill, if a larger diameter hole is needed. Since 1975, Reading and Bates and Titan have completed over 50 pipeline river crossings using Big Alice (Reading and Bates Construction Co., 1980; Anon., 1978).

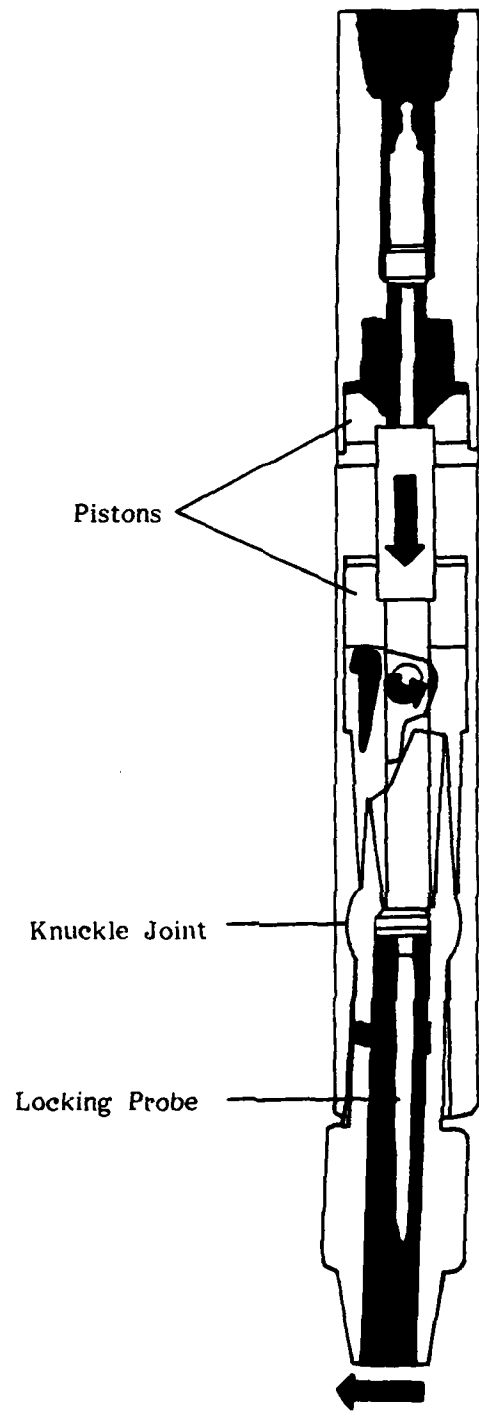
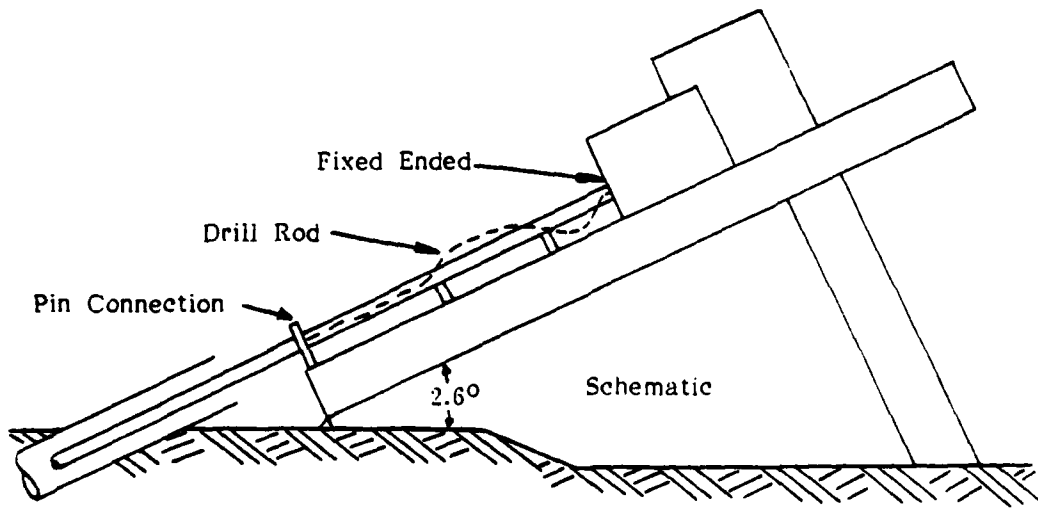

Figure 8. The Dyna-Flex® Hydraulically Actuated Bent-Sub (Harding et al., 1976)



b) Titan Contractor's Drill Carriage

Figure 9. Titan Contractor's Big Alice Drill Rig (Dowding, 1976 and Reaching and Bates Construction Company, 1980)

E. Application of Directional and Directionally-Controlled Horizontal Drilling to Lagoon Bottom Sealing

1. Directional Drilling

Directional drilling, as we have defined the technique, is limited to approximately 5° rate of bend per 30 m of dogleg (Refer to Section IIC). For a small shallow lagoon, such as the selected standard lagoon, a rate of bend of greater than 70° per 30 m of dogleg is required. This rate of bend is far beyond the capability of the current state-of-the-art equipment. The bend angle necessary will decrease as the lagoon or landfill becomes larger and deeper, however, the directional drilling technique will still be more costly and difficult than directionally-controlled horizontal drilling. Therefore, only directionally-controlled horizontal drilling methods will be further considered for bottom sealing an existing lagoon or landfill.

2. Directionally-Controlled Horizontal Drilling

a. Optimizing Drilling Paths

The standard lagoon selected is 45.7 m long by 30.5 m meters wide and 2.4 m deep. For drilling purposes, it is easier to control the bit if the holes are drilled from both sides of the lagoon and meet in the middle (see Figure 2b, 2c). If the drilling operator attempted to drill under the entire length of the standard lagoon and emerge on the other side (similar to a pipeline crossing under a river bed), the chances are very high that the bit would deviate upward and penetrate the lagoon bottom. The high probability of the upward deviation of the bit is due to the large build-up angle required to go under and come up given the small size of the standard lagoon. For large lagoons, this build up angle may be sufficiently small so that upward bit deviation could be avoided and the complete length of the lagoon could be drilled in one operation.

The drill entry points will be spaced evenly along the width of the lagoon at 1.5 m intervals as shown in Figure 10. These points are spaced to allow overlapping of the grout seeping from the drill holes. Since grout spread is dependent on characteristics of both the soil and the grout, the actual appropriate spacing must individually determined for each particular site. An extra leg will be drilled at each end to provide a bottom for vertical grouting of the ends. Thus, a total of 46 (2x23) directionally-controlled horizontal holes and 66 (2x33) vertical holes will have to be drilled to completely seal the lagoon.

The next step is to determine the depth at which the seal is to be placed under the lagoon. Factors which must be considered in this decision are: 1) the subsurface geohydrology of the area, 2) the permeability of the soil under the lagoon and thus its groutability, 3) the drillability of the soil under the lagoon, 4) the effect of the drilling mud on this formation, the lagoon, ground water and on the grout selected, and 5) whether the build-up angle can be obtained in a reasonable horizontal distance and with reasonable grout costs.

The subsurface geolydrological features of the standard lagoon have been specified (refer to Table I and Figure 1). Below the lagoon is approximately 3 m of a clay-sand. The next 3 m are a plastic-clay and the layer above the aquifer is a silty sand. The plastic-clay layer cannot be grouted

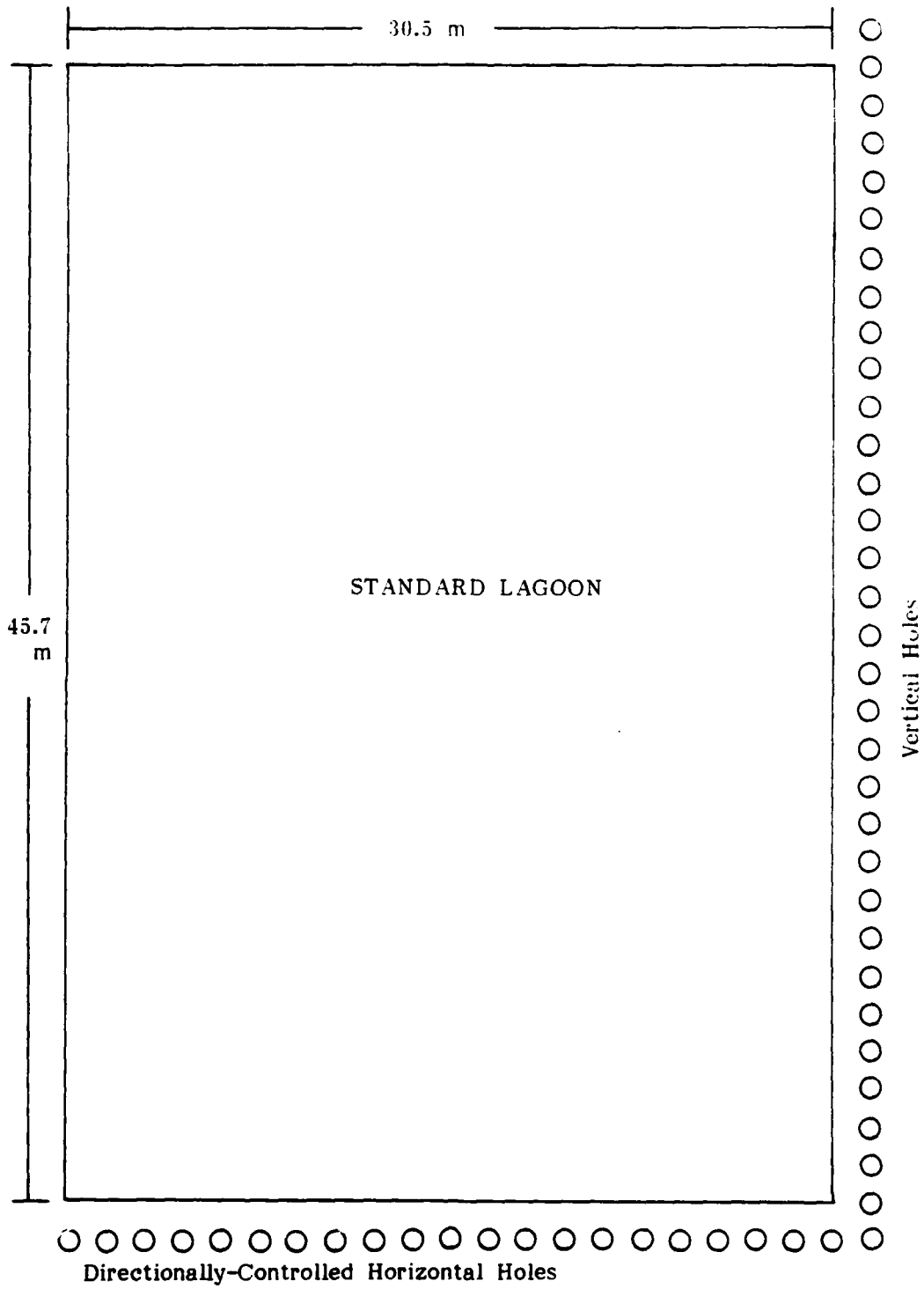

Figure 10. Drilling Patterns for Bottom Sealing the Standard Lagoon

due to its low permeability. It is also difficult to control the direction of the horizontal drilling through this layer. The relationship between soil permeability and grouting was discussed in a companion report (Sommerer and Kitchens, 1980) and will not be detailed here. In essence, the permeability coefficient of the soil must be 10^{-5} cm/sec for low viscosity chemical grouts and 10^{-2} cm/sec for high viscosity chemical grouts and particulate grouts. The silty-sand layer immediately above the aquifer would be easily grouted. This layer will be very expensive to drill and grout due to: 1) the long paths that must be drilled, 2) the difficulty in directionally penetrating the plastic-clay layer, 3) the large amount of grouting material needed, and 4) the possibility of fracturing the plastic-clay during grouting. The clay-sand layer just below the lagoon would, therefore, be the formation of choice for grouting. Grouting of this layer requires the least amount of drilling, and does not require drilling through or grouting the plastic-clay. However, there are other problems which could make grouting of this formation impractical. These problems include:

- the drilling build-up angles needed
- low permeability of the layer
- potential for fracturing the lagoon bottom during the drilling operation.

These problems will be addressed in the following sections.

The initial question which must be resolved is the ability to directionally control the horizontal drill holes into this layer. To determine if directionally-controlled horizontal drilling is feasible, one can refer to Figures 11 and 12. In Figure 11, the geometry of the drilling operation is shown. The drilling will be performed by a Titan Construction rig - Big Alice or their smaller version of this rig. The drill rig is situated so that the bit penetrates the ground at an angle of approximately 26° above the horizontal (see Figure 9). This angle can be varied somewhat (between approximately 20° and 30°). Thus, the angle, δ , can be determined from the drill rig position. The radius of curvature of the dogleg can be determined by the angle of build-up. The relationship between radius of curvature and build-up angle, α , is shown in Figure 12. As discussed in previous sections, the optimum build-up angle is $5^\circ/30$ m. Maximum build-up angles which can be sustained are approximately $15^\circ/30$ m. Thus, to determine if the drilling operation is feasible, one can select build-up angles, determine the radius of curvature from Figure 12 and calculate the horizontal distance and depth required before the drill bit will go completely horizontal from Figure 11. The results of these calculations are presented in Table III.

For this drilling operation to stop in the clay-sand layer, the vertical distance before the drill turns horizontal must be between 2.4 and 5.5 m. This criteria could be met under the following conditions (refer to Table III).

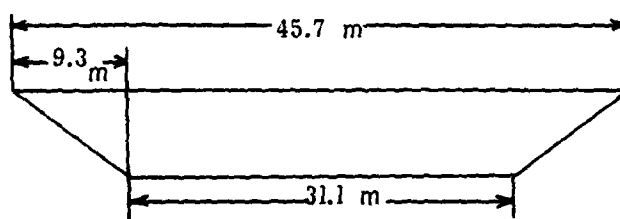
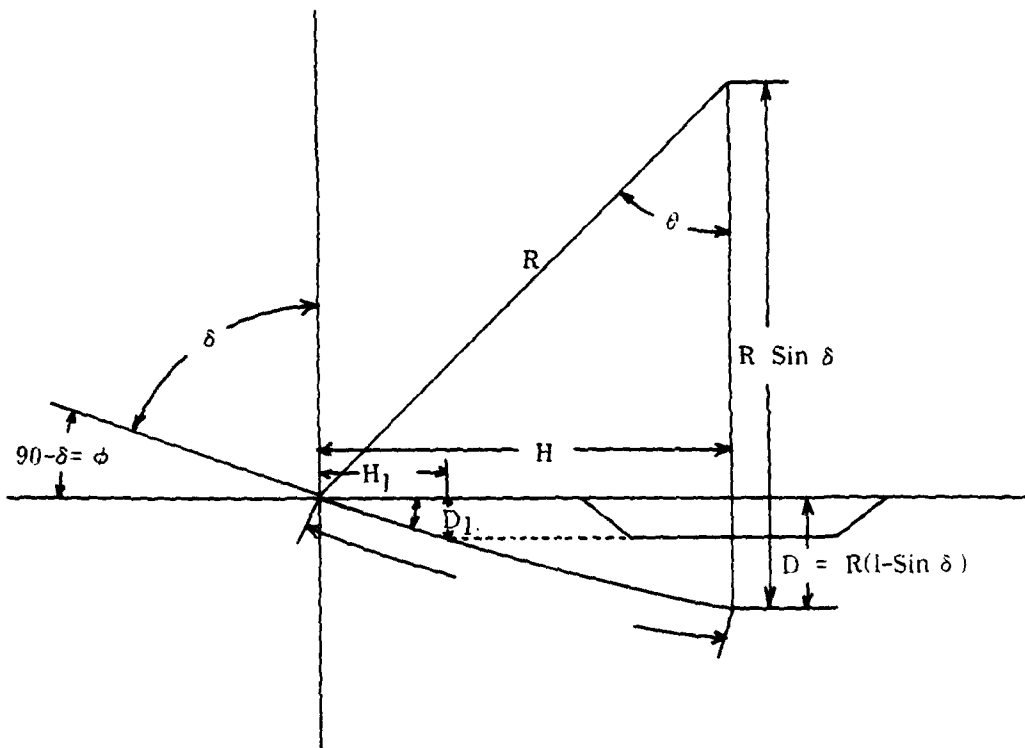

$$\sin \theta = \frac{H}{R}$$

$$\text{Dogleg} = \frac{2 R \theta}{360}$$

$$= H_1 = \frac{2.4}{\tan \phi}$$

For the drill path to miss the lagoon bottom $H > H_1 + 15.55 \text{ m}$

Figure 11. Geometry of the Directionally-Controlled Horizontal Drilling Operation Under the Standard Lagoon

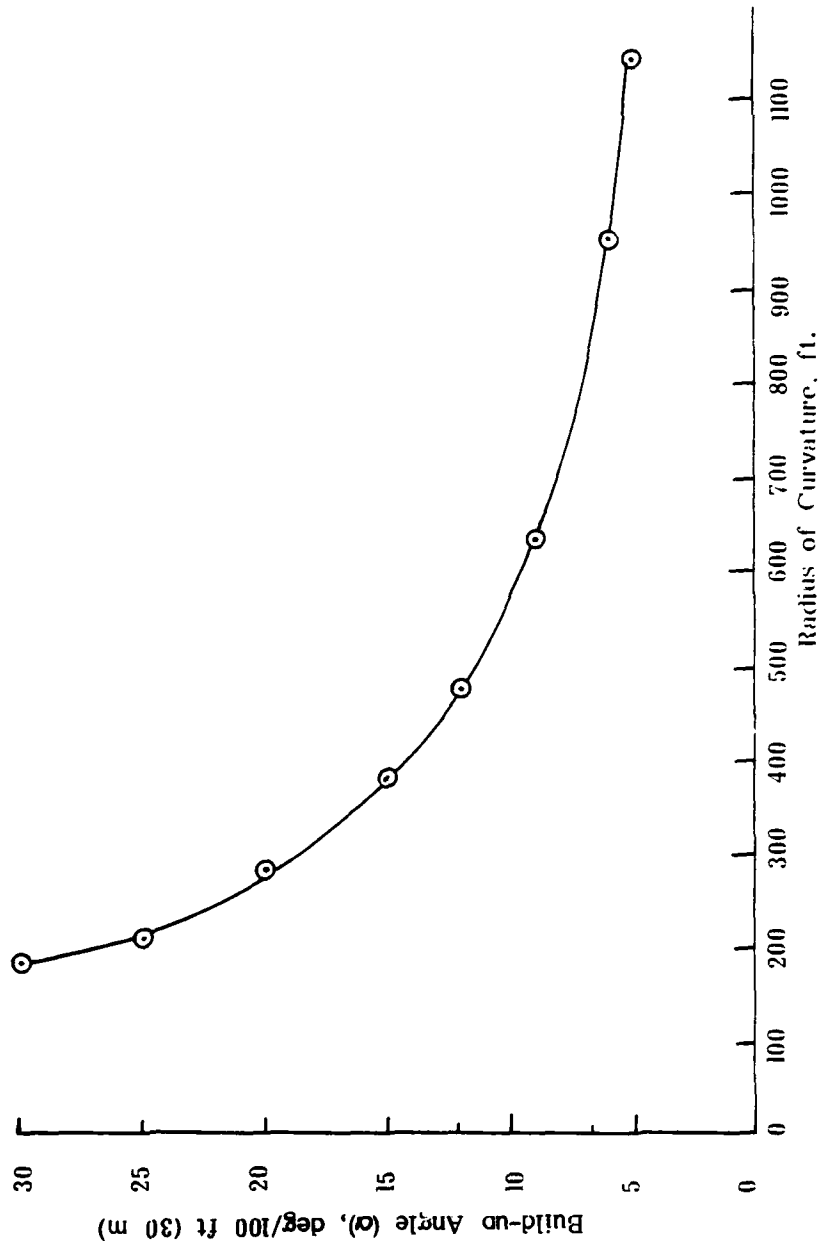

Figure 12. Radius of Curvature vs. Build-up Angle for Directionally-Controlled Horizontal Drilling (Dowding, 1976)

Table III. Horizontal and Vertical Drill Distances for Various Build-up Angles

The horizontal distance, $H = R \cos \delta$

The vertical distance, $D = R (1 - \sin \delta)$

δ (degrees)	α (degrees)	R (meters)	D (meters)	H (meters)
74	5	349.2	13.5	96.2
74	10	192.2	7.44	52.97
74	12	146.4	5.67	40.35
74	15	115.9	4.49	31.94
76	5	349.2	10.37	84.48
76	10	192.2	5.71	46.49
76	12	146.4	4.35	35.41
76	15	115.9	3.44	28.04
80	5	349.2	5.31	60.62
80	10	192.2	2.92	33.37
80	12	146.4	2.23	25.42
80	15	115.9	1.76	20.12

	A	B	C	D
Drillrig inclination, degrees	16	14	10	10
Build-up angle, degrees	15	12	5	10
Radius of curvature, m	115.9	146.4	349.2	192.2
Vertical distance, m	4.49	4.35	5.31	2.92
Horizontal distance, m	31.94	35.41	60.62	33.37
$H_1 + 15.55$, m	21.10	20.94	22.14	22.14
Dogleg, m	32.45	35.87	61.11	33.64

Next, it is necessary to make sure that the drill path will not penetrate the lagoon bottom. Therefore, H must be greater than $H_1 + 15.55$ m. Referring to the above figures, $H > H_1 + 15.55$ m in all cases, therefore, all the drilling paths are possible. The next step is to choose the path that will minimize the amount of grout required. Scenarios A, B and D have approximately the same path length while C is approximately twice that of the other scenarios. The path in condition D is only approximately 0.5 m below the lagoon bottom. With this path, the chances of accidentally penetrating the lagoon bottom with the bit or fracturing it with the drilling mud are relatively high. Condition A has a very high build-up angle which could present drilling problems. Condition B is probably the most cost effective set-up when potential technical problems are factored into increased drilling cost. Therefore, all cost will be based on Condition B.

b. Selection of the Drilling Mud

Additional technical problems which must be considered are the effects of the drilling mud on the formation, potential fracture of the formation with the drilling mud and the effects of the drilling mud on groutability. These problems are associated with the type of drilling mud used.

The drilling mud selection is as important to the operation as the drilling techniques. This mud performs a variety of functions which control the efficiency of the drilling operations (Dowding, 1976):

- the mud powers the down-hole motor
- it cools the drill bit and bearings
- it removes cuttings from drill face and carries them to the subsurface
- it suspends cuttings when fluid circulation is stopped
- it releases the cuttings in the surface fluid cleaning system

- it prevents cave-in of the borehole
- it must have properties which prevent fracture of the formation

A large variety of drilling muds are available to meet the requirements of specific jobs, although bentonite is the most commonly used mud. Bentonite is a clay material which swells to 10-20 times its original volume when properly mixed with water. The bentonite-water slurry is a thixotropic fluid which, in general, meets the requirements of a drilling mud. It can be pumped with sufficient velocity to power the down-hole motor and cool the bit and bearings without undue abrasion. Dirt and rock chips mix easily with the bentonite slurry and remain suspended in the slurry, thus allowing the cuttings to be carried away from the bit and back to the surface. During the cleaning operation, the cuttings are easily removed from the slurry by long-term settling and a shaker. Bentonite forms a filter cake by penetrating the soil around the borehole to a depth of approximately 1-2 cm. This filter cake prevents collapse of the hole and inflow of water. However, it also prevents grouting of the hole after the drilling operation is completed. The high pressures required to initiate fluid flow of the bentonite, e.g. motor shutdown for survey and re-start, can lead to fracture of the formation, with loss of drilling mud and possible loss of lagoon contents.

Several alternatives to solve these problems with drilling mud-grouting operations can be investigated.

1. Use of water as the drill mud. The Dyna-Drill will operate on water (Emory, 1980). The drilling operation is difficult because water is not a good medium for cuttings removal. It also will not stabilize the borehole and could flood the formation.

2. Use of a penetrating grout as the drilling mud. The drilling mud can be made to penetrate the formation to form the grout bottom. However, this technique also has several problems associated with it. The set-up time of the grout must be long and controllable. There is a fairly high chance that the downhole motor could be lost through premature grout set-up due to the high temperatures around the bit and motor. Deep penetration of the drilling mud also does not stabilize the hole unless the mud sets up which it must not do until the drilling is completed and the downhole motor removed.

3. Use of a degradable mud. Once the downhole motor is removed, an agent which degrades the mud could be added along with the grout. This method would be the most viable alternative if a degradable drilling mud which is compatible with the grout can be found.

c. Grouting of the Hole

To protect the down-hole motor, it is recommended that the motor be removed before grouting operations commence. The grout can be pumped down the hole through the drill string as it is removed. The selection of grouting material

is limited to low viscosity chemical grouts for our standard lagoon due to the low permeability of the soil. If the soil were of higher permeability, the less expensive cement or bentonite grouts or mixtures thereof could be used. For comparison purposes, the costs will be figured on both the chemical and particulate grouts.

The volume of grout required can be calculated from the number of bore holes, length of the bore holes, and porosity of the soil. As discussed previously, 46 directionally drilled and 66 straight holes will be required to completely seal the lagoon. Using drilling Condition B, each direction hole will be 35.87 m long and each straight hole, 4.35 m deep or a total grouting length of

$$46 \times (35.87 \text{ m}) + 66 (4.35 \text{ m}) = 1937.12 \text{ m}$$

The holes are placed at 1.5 m centers, and the porosity of the soil is 0.42, therefore, the total volume of a grout will be:

$$V = (0.80 \text{ m})^2 (1937.12 \text{ m}) (0.42)$$
$$V = 1635.82 \text{ m}^3$$

F. Costs for Grouting a Lagoon Bottom via Directionally-Controlled Horizontal Drilling

The costs of bottom sealing the standard lagoon via directionally-controlled horizontal drilling are presented in Table IV. The costs include vertical grouting to complete the seal around the lagoon. An alternative to vertical grouting is construction of a slurry wall to key into the grouted area. Costs for the directionally-controlled horizontal drilling of the lagoon bottom and slurry wall sides are also presented in Table IV. These costs do not include any provision for equipment failure.

Directionally-controlled horizontal drilling costs are figured on the basis of drilling in the long dimension. The greater part of the drilling cost is incurred by moving the rig from one hole to the next rather than by the actual drilling. Increasing the number of holes therefore increases costs much more than increasing the lengths of a fixed number of holes.

Table IV. Costs Associated with Bottom Sealing a Standard Lagoon via Directionally-Controlled Horizontal Drilling

A. Complete Grouting

Mobilization and demobilization			
Titan small drill rig			\$ 15,000
Drilling operations			
1 1/2 horizontal holes/day 46 days @ \$2500/day ⁽¹⁾			115,000
Grouting Operations			
cost of grout	silicate ⁽²⁾	\$11.65/m ³	19,060
1636 m ³	cement ⁽³⁾	\$8.83/m ³	14,450
	acrylamide ⁽⁴⁾	61.34/m ³	101,090
labor for vertical grouting 33 days @ \$1200/day ⁽⁵⁾			29,600
grouting equipment 2 vertical holes/day			
TOTALS/lagoon	silicate grout		\$ 188,660
	cement grout		\$ 184,050
	acrylamide grout		\$ 270,690

B. Bottom Grouting - Vertical Bentonite Slurry Wall

Mobilization and demobilization			
Titan small drill rig			\$ 15,000
Drilling operations			
1 1/2 horizontal holes/day 46 days @ \$2500/day ⁽²⁾			115,000
Grouting operations			
cost of grout	silicate ⁽²⁾	\$11.65 m ³	16,230
1393 m ³	cement ⁽³⁾	\$8.83/m ³	12,300
	acrylamide ⁽⁴⁾	\$61.79/m ³	86,070
Bentonite slurry wall (installed) ⁽⁶⁾			
73 m x 1 m = 73 m ² @ \$75.25/m ²			5,500
TOTALS/lagoon	silicate grout		\$ 151,730
	cement grout		\$ 147,800
	acrylamide grout		\$ 221,570

- (1) Garrett, 1980
- (2) Herndon and Lenahan, 1976b; Martin Marietta Corp., 1980
- (3) Martin Marietta Corp., 1980
- (4) Martin Marietta Corp., 1980; Herndon and Lenahan, 1976b
- (5) Fleming, 1980
- (6) Hayward-Baker, 1980

III. BOTTOM SEALING AN EXISTING LAGOON OR LANDFILL VIA VERTICALLY DRILLING THROUGH THE SITE

A. Background

A second method of bottom sealing an existing lagoon or landfill is to drill vertical grout holes directly through the refuge. This type of bottom sealing can be accomplished by an extension of grout curtain technology or by "pancake slurry jetting". The grout curtain technology was discussed in a companion report (Sommerer and Kitchens, 1982), therefore, this section will be limited to the specific application of grouting under an existing lagoon.

B. Application of Vertical Grouting to Bottom Sealing an Existing Lagoon or Landfill

The major differences between grouting to form a grout curtain and grouting under an existing lagoon are:

- the drilling and possibly the grouting equipment must be supported over the area
- the drilling operation occurs through the wastes
- the grouting operation all takes place below the waste

Due to these operational differences, bottom sealing via vertical grouting is even more difficult and must be more carefully planned than grout curtain operations.

The initial step in bottom sealing an existing site via vertical grouting is a detailed subsurface survey of the area. This survey should determine the vertical and horizontal limits of the waste site as well as the subsurface soil and hydrological characteristics. Tolman *et al.* (1978) suggested a grid pattern be drilled through the waste sites on 1.5 to 1.8 m centers. This pattern is reasonable if the site is large and its characteristics are unknown. For a small site for which data are available, only a few boreholes may be necessary. Once the geometry of the site is established, the depth of the soil to be grouted must be determined. It is recommended that a 1.5 m layer of soil be maintained between the bottom of the waste and the grouted material (Tolman *et al.*, 1978) to account for any irregularities in the bottom of the waste site. The depth to be grouted will also be determined by the permeability of the subsurface soil. Soil permeability must be greater than 10^{-5} cm/sec for successful grouting operations. Thus, a uniform layer of sufficient permeability must be selected for the bottom seal grout.

Grouting material which matches the soil permeability and is not affected by the wastes present in the site must then be selected. The selection of the grouting material should only be made after careful consideration of all the parameters which could affect the grout including soil permeability, waste compatibility, water wash-out, etc. (Sommerer and Kitchens, 1982; Herndon and Lenahan, 1976a,b). Once the

grouting material is selected, a detailed plan of the grout holes to be drilled and the grouting operation (volume of grout, pump rate, pumping time, pump pressure, grouting system to be used) must be made. Depending on the permeability of the soil, a grouting hole grid pattern with 1 - 1.5 m center-to-center distances is recommended.

There are a number of designs of grouting equipment, many of which are proprietary. The design used will most likely depend on the grouting contractor selected. One point which must be considered in selection of the contractor is the ability of the equipment to drill through a variety of wastes without seepage of the lagoon water or landfill leachate around the bore hole. The technology is available to prevent contamination of lower layers through the bore holes, however, the success of the job depends on the experience of the drillers.

The completed bottom grout seal will resemble that shown in Figure 13. Depending on the size and shape of the site, a grout curtain around the site, intersecting the bottom seal may be necessary.

C. Application of "Pancake Slurry Jetting" to Bottom Sealing an Existing Lagoon or Landfill

"Pancake slurry jetting" is an alternative technique of bottom sealing an existing lagoon via vertically drilling through the site. In the "pancake slurry jetting" technique, a series of disc cavities are formed under the site by a kerfer. Once cut, these cavities are backfilled with bentonite slurry to form the bottom seal. The techniques can also be used to form a side barrier around the site to form a complete seal.

A high pressure fluid drill, the kerfer, is used to drill the hole and the discs. This type of drill can be adapted for straight or 90° drilling as shown in Figure 14. The pattern of the cavity cut by the 90° jet can be controlled by the rotation of the drill string and the vertical movement of the drill string. With the proper movements, disc shaped and cylindrical shaped cuts can be made. The drill normally operates at pressures less than one kilobar at 75-150 Hp. The drill can be adapted to drill under water operations by surrounding the fluid jet with an air sheath. Very rapid drill rates can be accomplished with this drill (Huck *et al.*, 1980). Jet drilling is applicable to most types of soils, however, large amounts of rock will prevent the formation of an open cavity and continuous bottom seal.

Application of this drilling technique to bottom sealing a lagoon or landfill would involve essentially the same type of preplanning as vertical grouting. The geometry of the site and the subsurface soil characteristics must be determined. Next the grid for the drilling operation must be laid out. The spacing of the grid pattern will be determined by the subsurface layer where the kerfing will take place. This layer should be at least 1.5 m below the bottom of the wastes. If the subsurface layer is easily kerfed, a grid with greater than 1.5 m center-to-center hole distances should be acceptable. For less easily kerfed soils, closer spacing may be required. The plan view and side view of the "pancake slurry jetting" technique is shown in Figure 15.

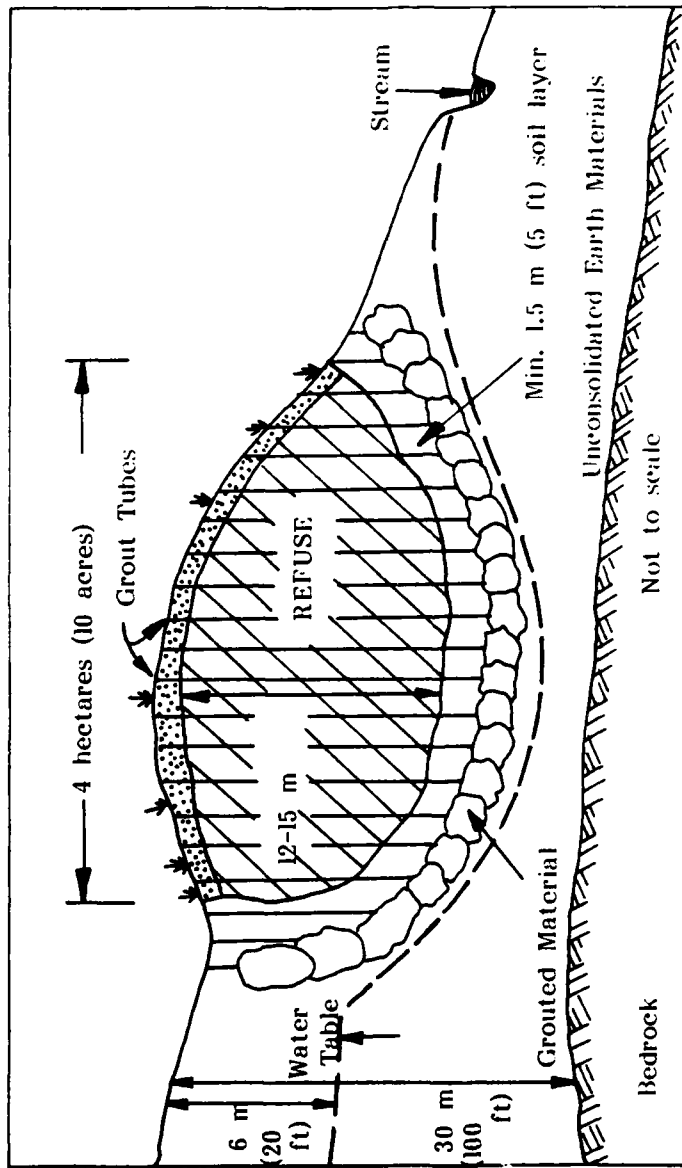

Figure 13. Cross Sectional of Grouted Bottom Seal Beneath a Landfill (Tolman et al., 1978)

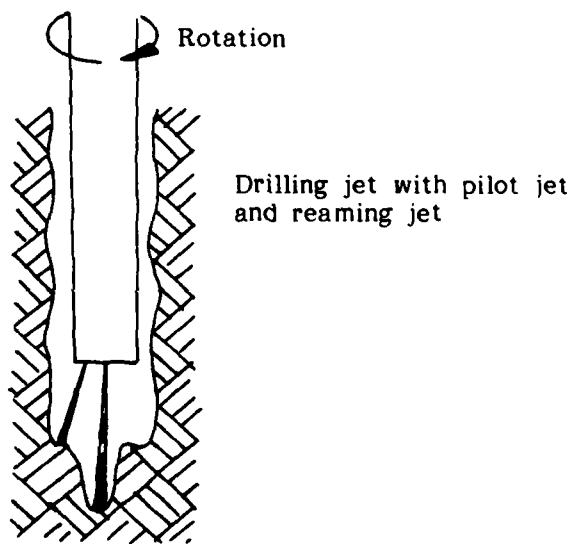
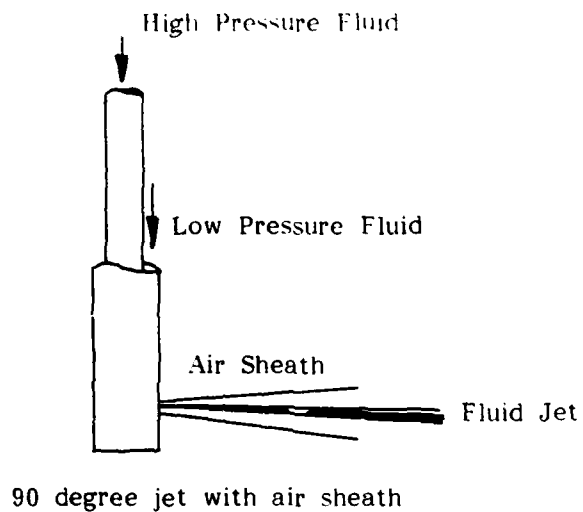

Figure 14. High Pressure Fluid Jetting (Huck et al., 1980)

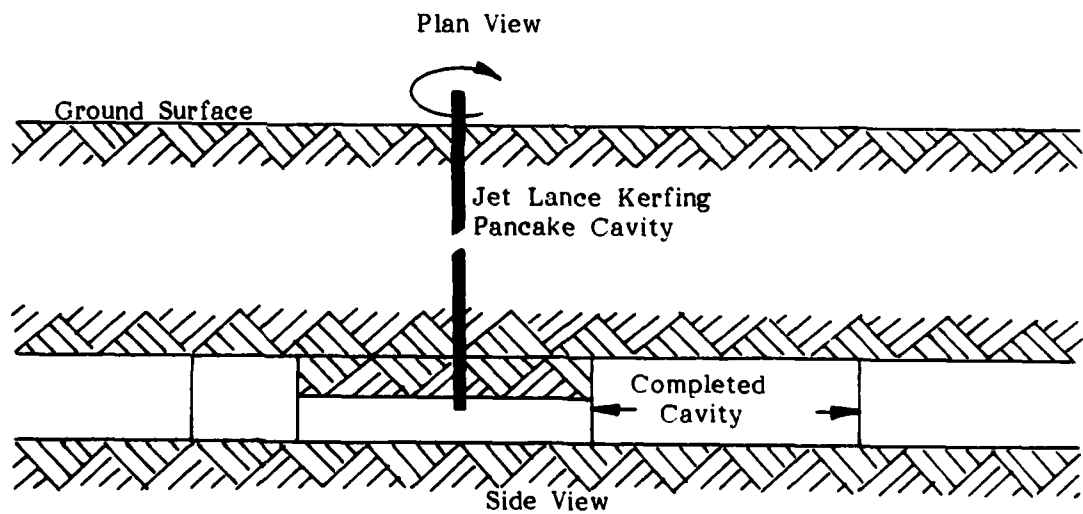
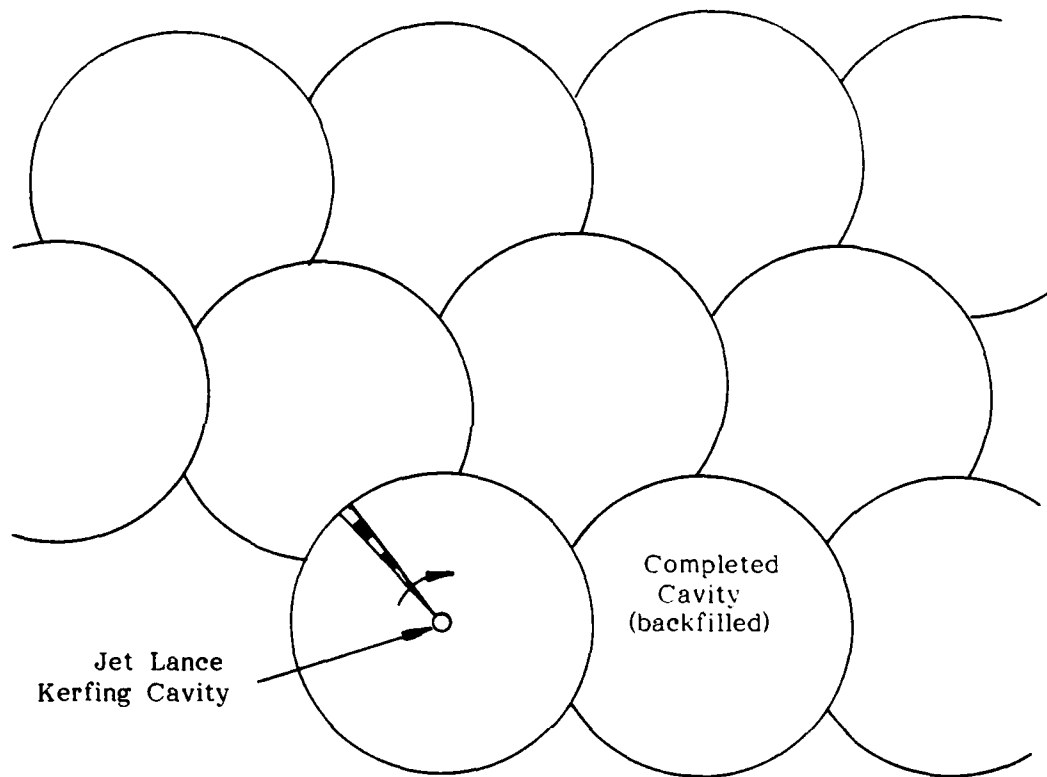

Figure 15. Procedure for "Pancake" Jetting to Place an Impermeable Floor Under a Waste Site (Huck et al., 1980)

The type of fill material to be used must be then selected. This material is preferably some form of bentonite slurry since bentonite is most compatible with drill operations.

D. Problems Associated with Vertically Placed Bottom Seals

The need to support the drilling, and possibly grouting equipment over the site, can be a major problem. For large lagoons, a barge can be used. For smaller lagoons with little or no water, a suspended movable platform may be needed. The drill rig and grouting operators will also come in contact with the wastes, therefore, they must be supplied with the appropriate safety equipment.

Drilling through wastes is also a problem. If proper precautions are not taken, the wastes can contaminate the lower soil layers or aquifer off-setting the purpose of the bottom seal. Significant hazards are also associated with drilling through wastes. These hazards include not only exposure of personnel and equipment to toxics, but the potential for explosives due to gas pockets in landfills and explosives in lagoons. Thus, all equipment must be non-sparking.

A third major problem is the inability to accurately monitor the vertical and lateral movement of the grout and thus ensure the integrity of the bottom seal. Boreholes placed at the expected lateral distance could be used, however, this method increases the number of bores which must be made and the potential for leakage of the wastes.

E. Economics of Bottom Sealing via Vertical Drilling Through the Site

The economics of grout and pancake slurry jet bottom sealing are based on the drilling grid pattern shown in Figure 16 with 1.5 m center-to-center distances. For the bottom seal, 651 holes will be required. Each of these holes will be 4.88 m deep. The bottom 0.91 m of each hole will be grouted or filled with bentonite slurry. To seal the edges will require one hundred 4.88 m holes that are totally grouted or filled with bentonite slurry. The approximate volume of grout for bottom grouting can be calculated from the following formula:

$$\text{Volume} = \pi(\text{radius of hole})^2 \times (\text{porosity of soil}) \times (\text{depth to be grouted}) \times (\text{number of holes})$$

$$\text{for bottom sealing } V_b = \pi(0.8 \text{ m})^2 (0.42) (0.91) (651) = 500.3 \text{ m}^3$$

$$\text{for side sealing } V_s = \pi(0.8 \text{ m})^2 (0.42) (4.88 \text{ m}) (108) = 445.1 \text{ m}^3$$

$$\text{Total volume of grout} = V_b + V_s = 945.4 \text{ m}^3$$

The amount of bentonite slurry needed for pancake slurry jetting can be approximately calculated from the formula:

$$\text{Volume} = \pi(\text{radius of hole})^2 \times (\text{depth of hole}) \times (\text{number of holes})$$

$$\text{for bottom sealing } V_b = \pi(0.8 \text{ m})^2 (0.91) (651) = 1191 \text{ m}^3$$

$$\text{for side sealing } V_s = \pi(0.8 \text{ m})^2 (4.88) (108) = 1060 \text{ m}^3$$

$$\text{Total volume of bentonite} = V_b + V_s = 2251 \text{ m}^3$$

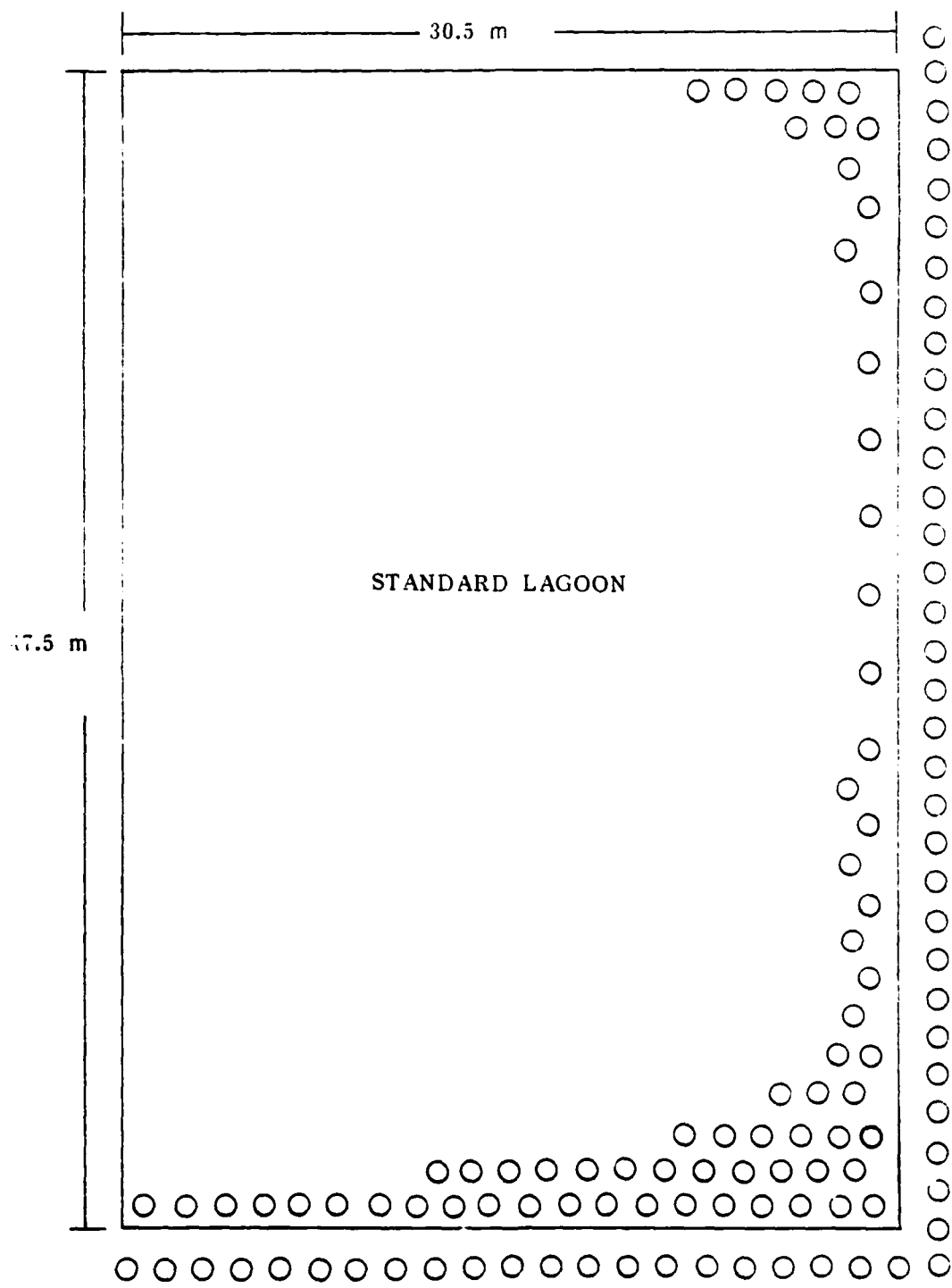

Figure 16. Grid Pattern for Bottom Sealing via Vertical Drilling

The costs associated with sealing a standard lagoon by each of these processes are shown in Table V. These costs are presented for grouting of the vertical seal and for a slurry wall vertical seal. They do not include any provision for equipment failure.

Table V. Costs for Bottom Sealing an Existing Lagoon via Vertical Grouting and Pancake Slurry Jetting

A. Vertical Seal Formed by Same Technique

1. Grouting

Mobilization		\$	800
Construction			
	3 bottom seal holes/day = 217 days		
	2 wall holes/day = 54 days		
	\$1200/day ⁽¹⁾ x 271 days		325,200
Materials	945.4 m ³		
	cement ⁽²⁾ \$8.83 m ³ of voids		8,347
	silicate ⁽³⁾ \$11.65/m ³ of voids		11,014
	acrylamide ⁽⁴⁾ \$61.79/m ³ of voids		58,416
<hr/>			
TOTAL COST/lagoon	cement grout	\$	334,347
	silicate grout	\$	337,014
	acrylamide grout	\$	384,416

2. "Pancaking"

Mobilization		\$	800
Construction			
	4 bottom seal holes/day = 163 days		
	2 wall holes/day = 54 days		
	\$1200/day ⁽¹⁾ x 217 days		260,400
Materials			
	2251 m ³ bentonite slurry @ \$0.31-1.39/m ⁽⁵⁾		698-3129
	(8.33 kg bentonite/m ³ slurry		
	\$24-\$152/ton bentonite)		
<hr/>			
TOTAL COST/lagoon			\$261,898-\$264,329

B. Slurry Wall Vertical Seal

1. Grouting

Mobilization		\$	800
Construction			
	3 bottom seal holes/day = 217 days		
	@ \$1200/day ⁽¹⁾		260,400
Materials	500.2 m ³		
	cement ⁽²⁾ \$8.83 m ³ of voids		4,420
	silicate ⁽³⁾ \$11.65/m ³ of voids		5,830
	acrylamide ⁽⁴⁾ \$61.79/m ³ of voids		30,910

IV. HYDRAULIC FRACTURING FOR BOTTOM SEALING AN EXISTING LAGOON OR LANDFILL

A. Background

Hydraulic fracturing is a technique for creating a fracture or system of fractures in a porous subsurface formation by pressure injection of a fluid into the formation through a well bore. This technique is applicable to permeable formations. In formations of low permeability, e.g. clay, a cavity is obtained instead of a fracture plane (Danesky, 1980). The hydraulic fracturing technique was first applied in 1947 to Klepper No. 1 well located in Kansas (Howard and Fast, 1970). Since 1947, hydraulic fracturing has been widely used by the oil industry to stimulate low productivity wells and overcome wellbore damage. This technique has also been used for industrial and nuclear waste disposal and is currently being investigated for *in situ* coal gasification processes.

B. Application of Hydraulic Fracturing to Bottom Sealing an Existing Lagoon or Landfill

Hydraulic fracturing or hydrofracing for bottom sealing waste disposal sites has been suggested by two companies, B.J. Hughes and Earth Tech Research Corporation (Huck *et al.*, 1980). The approaches presented by these firms are somewhat different, however, the hydrofracing technology is the same. Therefore, the factors which play a dominant role in hydrofracing will be discussed first followed by a discussion of each application technique.

1. Factors Affecting Hydrofracing

Hydrofracing as used in the oil well industry has required little control over the fracture plane. Generally, most oil well fractures are vertical in orientation. In contrast, hydrofracing for bottom sealing a landfill or lagoon requires that a horizontal fracture be created in a carefully controlled plane and over the desired area. The orientation and size of the hydrofracture are controlled by the: 1) stresses within the formation, 2) the uniformity of the formation, 3) the physical and chemical characteristics of the formation, 4) characteristics of the fracturing fluid.

The orientation of a hydraulic fracture will be determined by the stresses within the formation to be fractured (see Figure 17). If the formation is homogeneous and isotropic, the orientation and the fracturing pressure can be easily predicted by theory. However, most formations have been subjected to orogenic movement and exhibit anisotropy. The greater the non-homogeneity of the formation, the more difficult it is to predict fracture planes, therefore, it is desirable to only attempt hydrofracing a homogeneous formation under a waste site.

Hydrofracing occurs perpendicular to the plane of the least principal stress. If the Z plane has the least principal stress, then the fracture will be approximately horizontal. The stress in the Z plane is equivalent to the overburden stress which is approximately 230 g/cm^2 per meter of depth (1 psi/ft.). Theoretically,

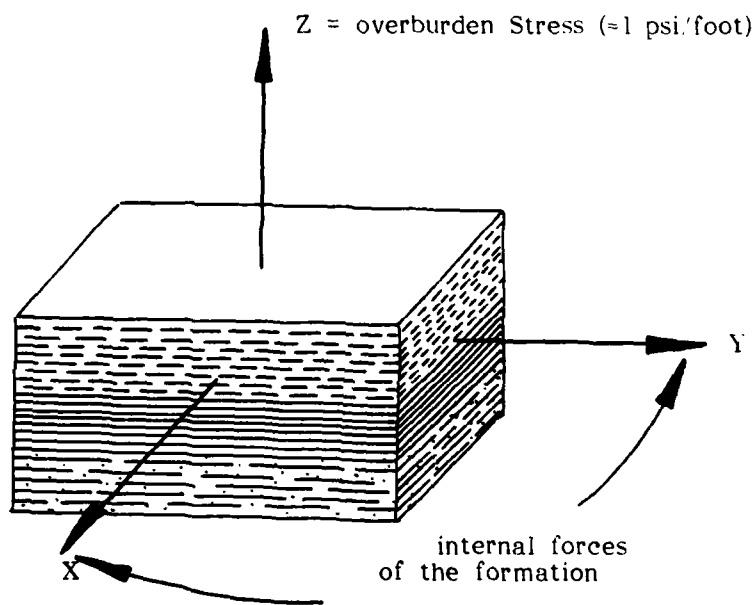

Figure 17. Principal Stress Planes (Mack, 1980)

the hydraulic pressure required to create a horizontal fracture is greater than or equal to the overburden pressure. However, under certain conditions, (acceptance of the overburden load by overlying bed) the pressure needed to fracture the formation is less than the theoretical overburden pressure.

The area covered by the hydrofrac is controlled by three flow mechanisms (Howard and Fast, 1970):

- result of the effects of fracturing fluid viscosity, C_I
- reservoir fluid viscosity and compressibility, C_{II}
- fracturing fluid wall - building characteristics, C_{III}

The three flow mechanisms can be expressed mathematically as the composite fracturing fluid coefficient, C_T where $\frac{1}{C_T} = \frac{1}{C_I} + \frac{1}{C_{II}} + \frac{1}{C_{III}}$. This coefficient is a measure of the effectiveness of the fracture fluid with more efficient fluids possessing lower coefficients (Howard and Fast, 1970). The area of the resulting fracture can be calculated from the following equation:

$$A = \frac{i W}{4\pi C^2} (e^{x^2} \cdot \text{erfc}(x) + \frac{2}{\pi} x - 1)$$

where

$$x = \frac{2C\sqrt{\pi t}}{W}$$

A = area of fracture

C = fracturing fluid coefficient

i = injection flow rate

W = fracture width during injection

c = isothermal coefficient of the compressibility of the fluid

$\text{erfc}(x)$ = complimentary error function of x

t = total pumping time

The selection of fracturing fluid for shallow fracturing is determined by the properties of the formation. In oil well hydrofracing, the properties of the reservoir and reservoir fluid also effect the selection of fracturing fluid. The chemical properties of the formation dictate whether an acid-based or non acid-based fluid is used. In limestone or other formations with high solubilities, an acid-based fluid is most effective. For fracturing insoluble formations, a water-based fluid is

most often used although oil-base fluids are used in water sensitive formations, e.g. certain clays. Minerals found in the formation can also dictate the type of fracturing fluid used since metal precipitates are formed with some fluids. The physical nature of the formation affects the physical properties of the fracturing fluid and also the ability to create a fracturing plane. These physical properties are normally obtained by additives rather than changing the chemical properties of the fluid.

2. Preplanning

Before any attempt is made to hydrofrac a horizontal plane under a waste disposal site, the formation stresses must be obtained and evaluated. The principal stress determinations are made with a rosette strain gage, step rate injection tests and pressure pulse interference tests. Soil type and formations, permeability of the formation area to be fractured, and depth of the waste site also must be determined. With the aid of a computer fracturing simulation model, the information from the site survey can be used to calculate the hydrofracing parameters, e.g., volume of fracture fluid, injection rate, injection pressure, hydraulic horsepower requirements, fracture area, fracture width, fracture orientation, size of propping agent, etc.

3. Hydrofracing - B.J. Hughes Concept

The B.J. Hughes (Mack, 1980) concept for hydrofracing under a waste site is shown in Figure 18. This concept uses one borehole drilled in the center of the standard lagoon site. Drilling is accomplished with a 90% fluid jet drill (see Figure 14) to act as a crack starter for the fracture. The hydrofrac procedure that is recommended is as follows. The fracture is to be made in the silty sand layer using B.J. Hughes Terra Frac T System. This fracturing fluid is a metal ion crosslinked, guar gum derivative hydroxypropylguar. The fracture fluid will be followed by a sand propping agent to maintain the fracture width. Once the agent is in place, the fracture fluid will be decomposed and pumped out of the well. Grout will then be pumped down the well and into the formation. The sides of the formation can be grouted down to the fracture and sealed into it. The seal will be approximately 1 cm thick.

4. Hydrofracing - Concept of Huck, Waller and Shimondle

Huck *et al.* (1980) proposed a hydrofrac concept which differs slightly from that of B.J. Hughes. Two or more boreholes are used as shown in Figure 19. The grouting material is used as the fracturing fluid. The two or more holes are pressurized simultaneously to create the fracture. As the fractures approach each other, the stress near the crack tips will tend to turn the fractures causing them intersect as shown in the figure.

5. Determining the Area Fractured

Theory cannot predict the exact area that will be fractured or the shape of the area. Generally, the fracture will extend radially out from the borehole. However, non-homogeneity of the subsurface formation could lead to a non-circular pattern. Therefore, some mechanism must be available in the field to

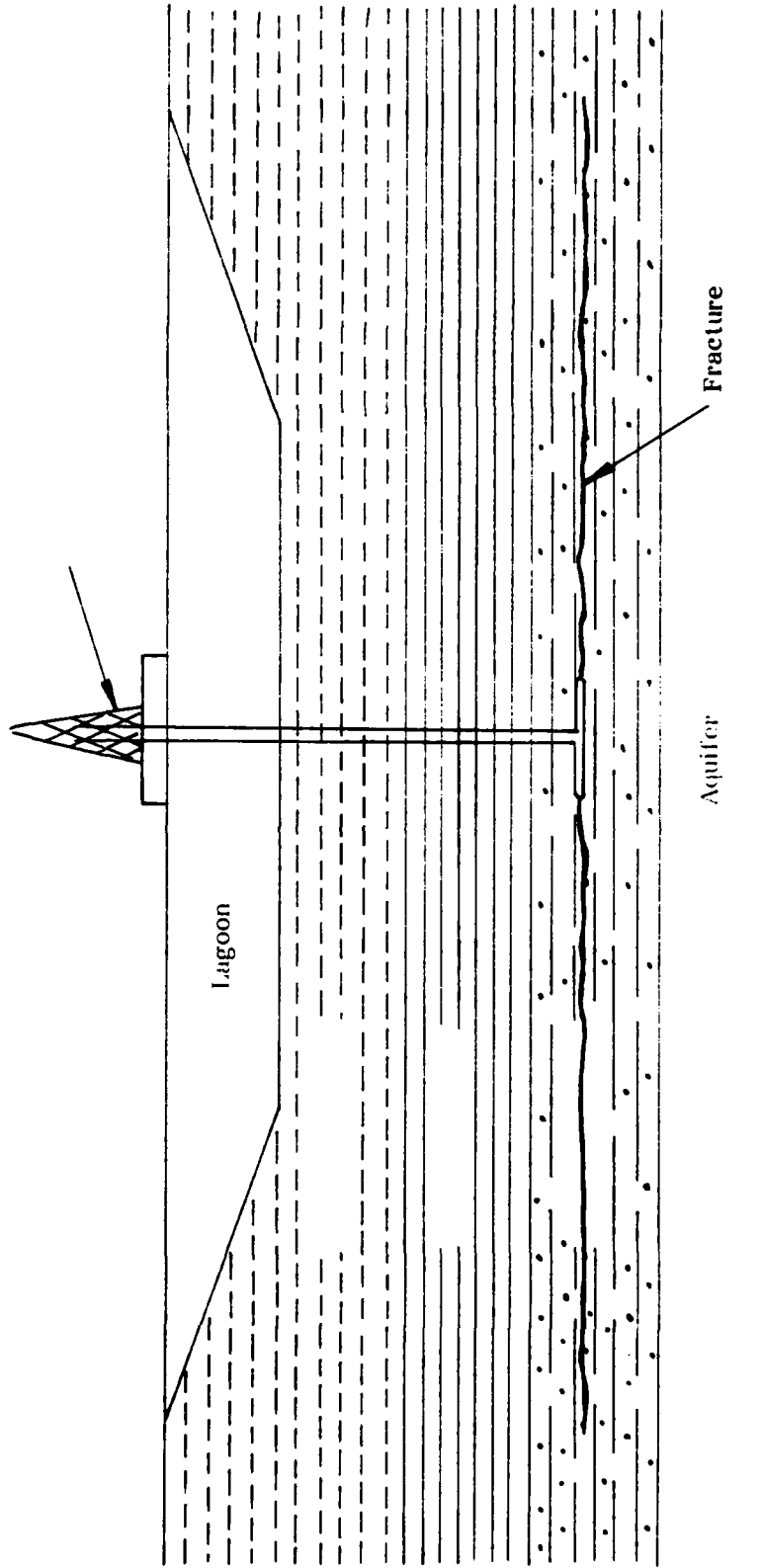

Figure 18. B.J. Hughes Concept for Hydrofracturing Under a Lagoon (Mack, 1980)

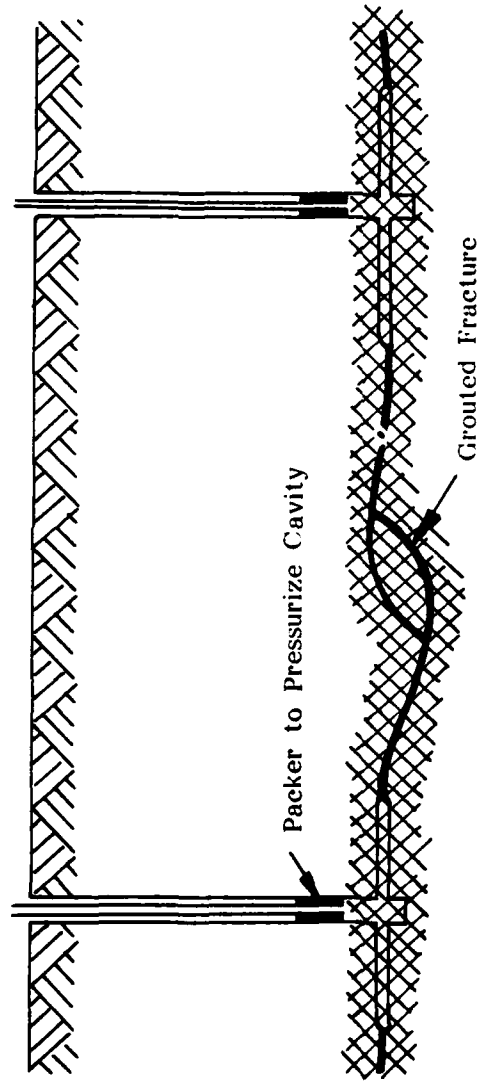

Figure 19. Controlled Hydraulic Fracture to Place an Impermeable Floor
Beneath a Waste Site (Huck et al., 1980)

determine the extent of the fracture. Tilt meters, to measure the lift of the earth, or seismic stations, to listen for fracture signals, could be used. However, these devices are expensive (approximately \$100,000/lagoon). Since a wall will have to be formed around the lagoon, the more economical method of locating the fracture is to drill the periferal boreholes first. If the grout appears in the boreholes from the fracture, then it would be very unlikely that a spot would be missed (Schuster, 1980).

C. Problems Associated with Hydrofracing Under a Waste Site

The main problem associated with hydrofracing under a waste site is the potential deviation of the fracture plane into the waste. This type of fracture could easily happen if the subsurface formations are not homogeneous and have not been adequately surveyed. This problem can be magnified due to difficulty in making the stress measurements. The measurements will probably not work in a wet hole through a clay material (Danesky, 1980).

A second problem is the potential existance of natural vertical cracks. These cracks could allow the wastes to flow into the hydrfrac and could wash the grout away. Small vertical cracks are easy to miss in a subsurface site survey. If contamination of a lower aquifer (one that does not penetrate the waste site) is observed, the chances of vertical cracks are fairly high (Danesky, 1980). Ground water must also not flow through the formation to be fractured since it would wash the grout away. The grout bottom layer will be very thin. To be effective, a highly impermeable and expensive grout must be used, e.g. acrylamide or epoxy.

D. Economics of Hydrofracing for Bottom Sealing a Standard Lagoon

The economics of hydraulic fracturing are based on a quote from B.J. Hughes (Mack, 1980) for hydrofracing a 2-acre lagoon in the sandy layer (depth approximately 10 m). Costs for the hydrofracing a 2-acre site were:

Well Drilling and Completion	\$10,000
Cementing	3,300
Fracturing	37,000
20% contingency	<u>10,000</u>
	\$60,300

The drilling and cementing costs will be about the same for a smaller lagoon, however, the costs of fracturing should be somewhat less. Fracturing costs for the smaller standard lagoon were estimated at \$30,000.

In addition to the hydrofracing, the grout costs and the cost to vertically seal off the lagoon must be taken into consideration. The volume of grout need was estimated by taking the anticipated volume of the fracture (36.6 m x 51.8 m x 0.010 m thick = 19 m³) and multiplying by five to take into account losses to the formation. Thus, the anticipated volume of grout need is 95 m³. As discussed in Section II, the

plastic clay layer is not groutable. Therefore, another method must be used to vertically seal the lagoon. This vertical wall must key into the grouted fracture. A bentonite slurry wall is probably the most economical of the alternatives and will be used in the cost analysis. This analysis is presented in Table VI.

Table VI. Costs for Bottom Sealing a Lagoon via Hydraulic Fracturing

Hydrofracing		
Well drilling and completing		\$ 10,000
Cementing		3,000
Fracturing		30,000
Contingency (20%)		8,700
Material for grouting		
95 m ³ of acrylamide grout ⁽¹⁾ @ \$61.79/m ³		5,870
Bentonite slurry wall (installed)		
165 m x 1 m = 165 m ² @ \$75.35/m ²		<u>12,430</u>
TOTAL COST/lagoon		\$ 70,000

(1) Martin-Marietta Corp. (1980); Herndon and Lenaham (1976b).

V. DEEP CHEMICAL MIXING (DCM)

A. Background

An alternate method of bottom sealing a lagoon (not applicable to landfills) is by a method called deep chemical mixing. This method of solidification or stabilization of soil under water was developed by Takenaka Komuten Co., Ltd., a Japanese based construction company. The specially designed mixer, shown in Figure 20, is used. Water and the solidifying chemical(s) are mixed in the proper ratio. The solidifying chemical slurry is pumped into the soil through the mixer shaft. The agitating wings of the DCM thoroughly mix the solidifying chemical with the soil. During the initial settling reaction, pollutants in the sludge are captured and incorporated into the final product.

B. Application of DCM to Bottom Sealing a Lagoon

The DCM is not available in the United States. However, a similar mixer could be built to treat lagoon bottoms. Approximately 0.61 m of bottom sludge should be treated to form a seal. For the standard lagoon, 895 m³ of bottom sediment must be solidified. A wide variety of solidification agents could be used, however, normal Portland cement should provide an adequate seal if it is compatible with the explosives. For DCM with Portland cement, Takenaka estimates a cost of \$49.44/m³ of solidified sludge (if done in Japan) (Kondo, 1980). Thus, total costs for bottom sealing a lagoon by this method would be \$44,250.

DEEP CHEMICAL MIXER

SOLIDIFYING CHEMICAL PLANT SHIP

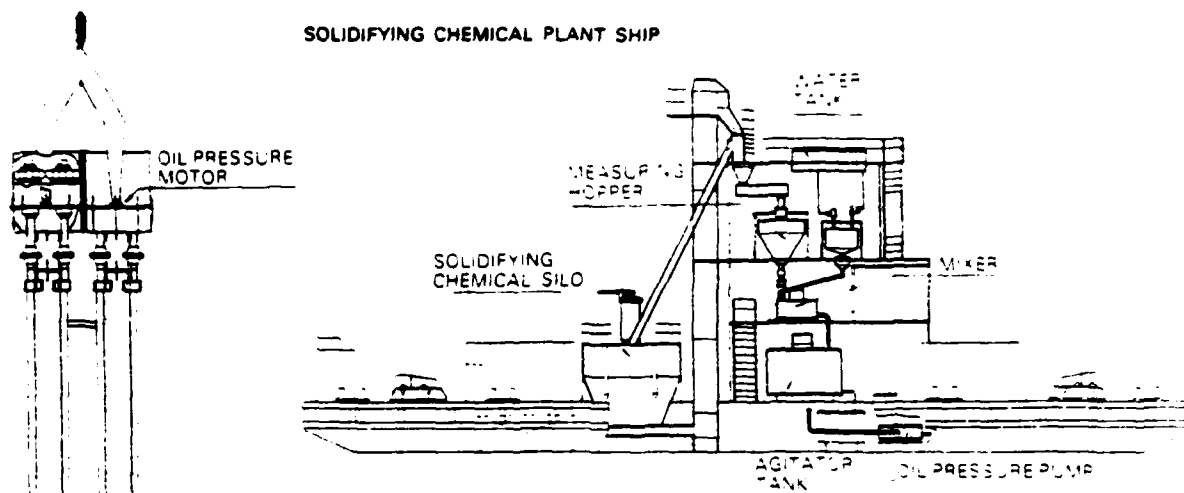

SHAPES AND ROTATING DIRECTIONS OF AGITATING WINGS

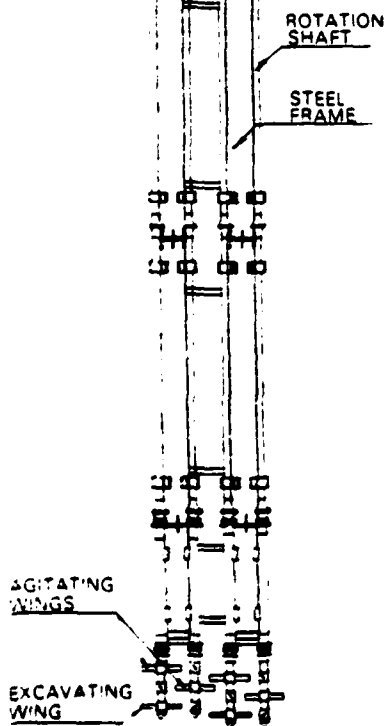
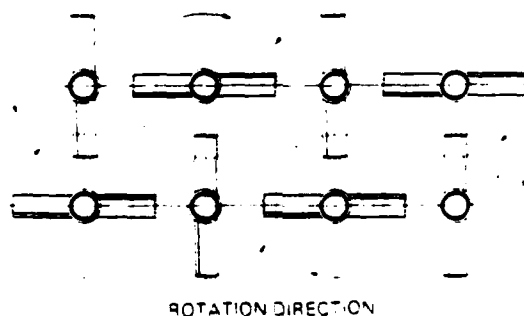

Figure 20. Deep Chemical Mixer Mounted on Barge (Takenaka Komuten, Ltd., 1980)

VI. FLOATING A LINER

Two methods of floating a liner to prevent further leaching from an existing lagoon are possible:

- floating a bentonite slurry
- floating a synthetic liner .

The most widely used method of floating a liner on an existing lagoon is performed by Dowell. For this type of seal, they spray the lagoon with their Spray Seal J-198. This polymer sorbs to the soil surface. After the initial J-198 spray, a slurry of bentonite is often sprayed on the lagoon. The seal is completed by a second application of the J-198 slurry. The J-198 slurry is a preblended mixture of synthetic polymers. The polymer and bentonite slurries sink to the bottom of the lagoon and form a relatively impermeable barrier. The efficiency of the seal made by the spraying process is not as good as a compacted material, however, it should provide a relatively impermeable membrane. Lifetime of the seal is estimated at approximately 7 years (Landreth, 1980). For the system to work, the pH must be maintained near neutral and the concentration of multivalent cations should be less than 750 mg/L. This type of seal will help prevent future leakage of the lagoon. It will also help prevent movement of chemicals in sediment by limiting the movement of water through the sediment.

To line a standard lagoon by floating bentonite is an inexpensive method of temporarily retarding leaching into the subsurface or ground water. The operation for a lagoon can be conducted in approximately two days. The J-198 is applied at the rate of 8.14 kg/100 m², the bentonite is applied at a rate of 1625 kg/100 m² as a 10/1 slurry (Parks, 1980). For the 1400 m² standard lagoon, 228 kg of J-198 and 22,750 kg of bentonite will be required. J-198 is \$4.96/kg and high quality bentonite can run as high as \$152/ton. Total materials cost for the standard lagoon will run approximately \$4,931. Labor and equipment rental for application are estimated at \$4,000 for a total cost of \$8,931/lagoon.

The method of floating a synthetic liner is applicable only to small lagoons. For this bottom sealing technique, a synthetic liner is floated on top of the lagoon and the water in the lagoon pumped from below the liner to the top of the liner. Because of the difficulties of assembling and handling a single sheet of plastic large enough to cover the entire area, lagoons of greater size than 50 m x 50 m are impractical to line by this method. The synthetic liner material must be compatible with the lagoon water and must be laid in one sheet since joining is not possible after installation. Installation of the liner should take about 3 days. The liner placed in this manner should prevent leaching for approximately 20 years or the lifetime of the liner material, provided it is not torn during installation.

Costs for floating a synthetic liner depend on the liner material used. Approximately 2000 m² of liner material are needed to line the standard lagoon. At \$8.00/m² of liner material, total materials cost would be \$16,000. Labor and equipment rental for three days are estimated at \$6,000 for a total cost for lining one lagoon of \$22,000.

VII. CONCLUSIONS AND RECOMMENDATIONS

Bottom sealing of an existing landfill or lagoon has received relatively little attention until recently. Techniques which have potential applicability for waste site bottom sealing are presented in Table VII. No evidence was found in the literature of bottom sealing an existing landfill. Two techniques have been successfully applied to bottom sealing lagoons or river bottoms - floating a bentonite liner and deep chemical mixing. Deep chemical mixing has been successfully performed in Japan. The mixer is not currently available in the United States. However, the technique appears to be feasible and cost effective. This method could be very effective for bottom sealing large leaking lagoons, *e.g.* Basin F at Rocky Mountain Arsenal, if a compatible material can be found. Floating a bentonite liner has been widely used in the midwest for sealing cattle and hog waste lagoons. This method does not require sophisticated equipment and is inexpensive. A reasonably impermeable seal can be obtained. Lifetime of the seal is approximately 7 years.

Other methods for bottom sealing an existing lagoon or landfill, *e.g.* directionally-controlled horizontal drilling, and vertical drilling with grouting, pancake slurry jetting and hydraulic fracturing with grouting, have been suggested. However, they have never been tried. Of these methods, hydraulic fracturing appears to be the least expensive. Serious technical questions concerning the existence of natural vertical fractures and the creation of vertical fractures must be answered. Hydrofracing experts seem to believe that stress measuring through a lagoon or landfill will be difficult and possibly unreliable. There is also consensus that a high probability of vertical fracturing exists and the only way to find out which way the fracture will run is "to try it."

Directionally-controlled horizontal drilling appears to be a viable but expensive alternative for bottom sealing a waste site. Grouting and the directional drilling will be a problem in clay soils. This method is probably more adapted to medium size sites rather than the very small or very large sites.

Vertical drilling through the site for grouting or pancaking presents the major problem of drilling through the wastes with a large number of boreholes. Leakage of the wastes and exposure of the personnel and equipment to toxic and explosive materials could occur.

In essence, the state-of-the-art in bottom sealing an existing waste site is almost non-existent. For lagoons, deep chemical mixing and floating a bentonite liner appear to be the most viable, cost effective techniques. However, their applicability is very site dependent and a significant amount of compatibility testing is necessary before the techniques can be applied. These techniques should be further investigated for their applicability to specific Army lagoon problems.

Table VII. Summary of Methods for Bottom Sealing a Lagoon or Landfill

Methodology	Type of Grout	Cost/Lagoon, \$	Advantages	Disadvantages
Directionally Controlled Horizontal Drilling with Vertical Grouting	cement, silicate acrylamide	\$194,050 \$188,660 \$270,690	Equipment reasonably well developed Tried on river crossings, no inter-action of drill with wastes	Directional control an art and not a science. Never been done. Grouting may be a problem in soils of low permeability. Time consuming.
Directionally Controlled Horizontal Drilling Vertical Bentonite Shurry Wall	cement silicate acrylamide	\$147,000 \$151,730 \$221,570		
Vertical Drilling Vertical Grouting	cement silicate acrylamide	\$334,347 \$337,014 \$384,416	Drilling technology well developed	Never been tried. Potential inter-action of drilling operation with waste. Grouting can be a problem in soils of low permeability. Drill rig must be suspended above site. Toxicity problems with wastes.
Vertical Drilling Vertical Bentonite Shurry Wall	cement silicate acrylamide	\$278,005 \$279,460 \$304,540		
Pneaking (complete)	bentonite	\$261,898- \$284,329	Equipment is developed	Never been tried. Potential inter-action of drilling operation with wastes. Drill rig must be suspended above site. Toxicity problems with wastes.
Pneaking, Vertical Bentonite Shurry Wall	bentonite	\$209,259- \$240,536		
Hydraulic Fracturing Vertical Bentonite Shurry Wall	acrylamide	\$70,000	Equipment and fracture fluids are available	Never been tried. Potential for vertical fracture and contaminants of ground water.
Deep Chemical Mixing	cement	\$44,250	Shown to be effective in Japan.	Equipment not available in the U.S. Could be a problem with the explosives.
Floating a Bentonite Liner	J-198 bentonite	\$8,931	Has been used successfully in the midwest.	Has limited lifetime. Not as good a seal as the compacted material. Does not place a seal under the contaminated sediment.
Floating a Synthetic Liner	polyethylene or hypalon	\$22,000		Applicable only to small lagoons. Never been tried.

The technical risks associated with hydraulic fracturing and vertical drilling are too high to warrant their further development at this time. Directionally-controlled horizontal drilling could be developed into a viable bottom seal technique. If the horizontal drilling operation could be mated with the pancake slurry jetting, the problems of grouting and uniform sealing could be overcome. Further development of the directionally-controlled horizontal drilling method for bottom sealing a waste site appears to be warranted. However, significant field testing must be conducted before the method can be applied to bottom sealing a waste site.

VIII. REFERENCES

- Anon. (1978), "Installation Method Breaks New Ground," Offshore, March.
- American Colloid (1980), Personal communication, Skokie, Illinois.
- Bak, D.J. (1978), "Gyro Enhances Directional Drilling Capabilities," Design News, 34(21): 66.
- Barnett, J.H. (1979), "Sandia/DOE Geothermal Drilling and Completion Technology Development Program," Geothermal Resources Council, Transactions, 3: 31-34.
- Brown, D.E. (1980), "Programmed Math Keeps Directional Drilling on Target," Oil and Gas Journal, 78(12): 164-167, March 23.
- C&E News (1979), "Underground Coal Gasification: A Crucial Test," December 3: 19-29.
- Congram, G.E. (1978), "Horizontal Drilling Speeds Pipeline Stream Crossing," Oil and Gas Journal, March 6.
- Danesky, A. (1980), Personal communication, Halliburton Company, Duncan, Oklahoma.
- Diamond, W.P.; Oylar, D.C. and Fields, H.H. (1977), "Directionally Controlled Drilling to Horizontally Intercept Selected Strata, Upper Freeport Coalbed, Greene County, Pennsylvania," Bureau of Mines, Report of Investigations 8231.
- Dowding, C.H. (1976), "Feasibility of Horizontal Boring for Site Investigation in Soil, Final Report," Massachusetts Institute of Technology, report MIT-CE-R76-15. NTIS, PB 293 055.
- Dowell (undated), "Dowell Soil Sealant Systems," Product Brochure.
- Emory, M. (1980), Personal Telephone Conversation, October 27, 1980, Dyna-Drill, Inc.
- Federal Bentonite (1980), Personal communication, Aurora, Illinois.
- Fleming, C.W. (1980), Personal communication, letter dated August 4, McCollum General Services, Division of Oliver B. Cannon and Sons, Inc.
- Garrett, L.D. (1980), of Reading and Bates Construction Co. Meeting on September 24, 1980 in Houston, Texas.
- Garrison, E.P. (1975), "Down-Hole Motors," Background Papers for a Drilling Technology Workshop. Park City, Utah, June 1975, National Research Council. NTIS, PB 253 378.

- General Electric Company, Space Division (1977), "Electrodril System Field Test Program. Phase I - Final Report, May - December 1976," report BERC/TFR 77/4.
- Harding, J.C.; Mack, Jr., W.M.; Sutl, W.L. and Tracy, N. (1976), "Drilling and Preparation of Reusable, Long Range, Horizontal Bore Holes in Rock and in Gouge. Vol. III. A Development Plan to Extend Penetration Capability, Increase Accuracy, and Reduce Costs," Foster-Miller Associates, Inc. NTIS, PB 293 060.
- Hayward-Baker (1980), Personal communication, Odenton, Maryland.
- Herndon, J. and Lenahan, T. (1976a), "Grouting in Soils, Volume I: A State-of-the-Art Report," Halliburton Services, report FHWA-RD-76-26. NTIS, PB 259 043.
- Herndon, J. and Lenahan, T. (1976b), "Grouting in Soils, Volume 2: Design and Operations Manual," Halliburton Services, report FHWA-RD-76-27. NTIS, PB 259 044.
- Howard, G.C. and Fast, C.R. (1970), Hydraulic Fracturing, Society of Petroleum Engineers of AIME, Dallas, Texas.
- Huck, P.J.; Waller, M.J. and Shimondle, S.L. (1980), "Innovative Geotechnical Approaches to the Remedial In-Situ Treatment of Hazardous Materials Disposal Sites," Control of Hazardous Material Spills, Proceedings of the 1980 National Conference on May 13-15, 1980, Louisville, Kentucky, pp 421-426.
- Kondo, M. (1980), Personal communication, letter, Takenaka Komuten Co., Ltd., Tokyo, Japan.
- Landreth, R. (1980), Personal communication, EPA, Cincinnati, Ohio.
- Mack, D.J. (1980), Personal Visit, B.J. Hughes, Arlington, Texas.
- Martin Marietta Corporation (1980), Personal communication, Washington, D.C.
- Maurer, W.C.; Rowley, J.C. and Carwile, C. (1978), "Advanced Turbodrills for Geothermal Wells," Geothermal Resources Council, Transactions, 2: 411-414.
- McDonald, W.J.; Rehm, W.A.; and Maurer, W.C. (1979), "Improved Directional Drilling Will Expand Use," The Oil and Gas Journal, 77(9): 108-112, 117-118, 120, 125.
- Millheim, K. (1979), "Hard-Formation Directional Drilling Calls for Special Care," The Oil and Gas Journal, 77(7): 136, 138.
- Oyler, D.C.; Diamond, W.P. and Jeran, P.W. (1979), "Directional Drilling for Coalbed Degasification. Program Goals and Progress in 1978," Bureau of Mines, Report of Investigations 8380.

- Parks, C.F. (1980), Personal conversation, Dowell, Tulsa, Oklahoma.
- Pettitt, R.A. (1977), "Los Alamos Hot Dry Rock Geothermal Energy Projects," Geothermal Resource Council, Transaction, 1: 241-242.
- Reading and Bates Construction Company (1980), "River Crossings. Directionally Controlled Horizontally Drilled," Product Brochure.
- Schuster, C.L. (1980), Personal communication, Sandia Laboratories, Albuquerque, New Mexico.
- Sommerer, S. and Kitchens, J.F. (1982), "Engineering and Development Support of General Decon Technology for the DARCOM Installation Restoration Program. Task I. Literature Review on Ground Water Containment and Diversion Barriers," Atlantic Research Corporation.
- Stephens, D.R. (1979), "Costs of Drilling, Completing and Linking Process Wells for Underground Coal Gasification as a Function of Linking Method, Coal Bed Thickness and Depth," Proceedings of the 5th Underground Coal Conversion Symposium, Alexandria, Virginia, June 18-21, 1979, 163-176. NTIS, CONF-790630.
- Takenaka Komuten Ltd. (1980), "Deep Chemical Mixing Method, DCM," Product Brochure.
- Thompson, J.C. (1979), "Deep Directional Drilling," Deep Drilling and Product Symposium Proceedings of the 4th Amarillo, Texas, April 1-3, pp 7-14. Society of Petroleum Engineers of AIME, Dallas, Texas.
- Tolman, A.L.; Ballestero, A.P. Jr.; Beck, W.W. Jr. and Emrich, G.H. (1978), "Guidance Manual for Minimizing Pollution from Waste Disposal Sites," A.W. Martin Associates, Inc. report EPA-600/2-78-142. NTIS, PB 286 905.
- Varnado, S.G. and Stoller, H.M. (1978), "Geothermal Drilling and Completion Technology Development," Geothermal Resources Council, Transactions, 2(Sec. 2): 675-678.
- Wentzel, R.S.; S. Sommerer, and J.F. Kitchens (1982), "Engineering and Development Support of General Decon Technology for the U.S. Army's Installation Restoration Program. Task 2. Treatment of Explosives Contaminated Lagoon Sediment - Phase I. Literature Review and Evaluation," Final Report, Atlantic Research Corporation.

LIST OF ABBREVIATIONS

@	-	at
Acc.	-	accuracy
α	-	build-up angle
D	-	vertical distance
DC	-	direct current
dia	-	diameter
oF	-	temperature in degrees Fahrenheit
Ft	-	feet
H	-	horizontal distance
Hr	-	hour
"	-	inch
Inc.	-	inclination
K	-	thousand
kg	-	kilogram
m	-	meter
m ²	-	square meter
m ³	-	cubic meter
$\mu\text{g/g}$	-	micrograms per gram (parts per million)
mD	-	milliDarcy
ϕ	-	angle of inclination of drill rig
PSI	-	pounds per square inch
R	-	radius of curvature
Res.	-	resolution
rpm	-	revolutions per minute
δ	-	90- ϕ
θ_1	-	original angle of inclination
θ_F	-	final angle of inclination
V	-	volt

Distribution List

Defense Logistics Studies Information Exchange
Ft. Lee, Virginia 23802

2 copies

Defense Technical Information Center
Cameron Station, Alexandria, Virginia 22314

12 copies

Chemical Systems Laboratory
Attn: DRDAR-CLJ-I
Aberdeen Proving Ground, Maryland 21010

2 copies

U.S. Army Toxic and Hazardous Materials Agency
Aberdeen Proving Ground, Maryland 21010

8 copies

DATE
ILME