

MICROCOPY RESOLUTION TEST CHART
NATIONAL BUREAU OF STANDARDS-1963-A

AD A117570

2

FTD-ID(RS)T-682-82

FOREIGN TECHNOLOGY DIVISION



METHODS AND TECHNIQUES OF EXPERIMENTAL
RESEARCH ON THE ATMOSPHERE

(Selected Articles)



DTIC
JUL 27 1982
H

DTIC FILE COPY

Approved for public release;
distribution unlimited.



82 07 27 114

UNEDITED MACHINE TRANSLATION *of*

FTD-ID(RS)T-0682-82

18 June 1982

MICROFICHE NR: FTD-82-C-000812

METHODS AND TECHNIQUES OF EXPERIMENTAL RESEARCH
ON THE ATMOSPHERE (Selected Articles)

English pages: 52

Source: Trudy Tsentral'noy Aerologicheskoy
Observatorii, Metody i Tekhnika
Eksperimental'nykh Issledovaniy Atmosfery (USSR) 11/102
"Gidrometeoizdata", Moscow, Nr. 102, 1971,
pp. 3-23; 139-140

Country of origin: USSR

This document is a machine translation.

Requester: FTD/WE

Approved for public release; distribution unlimited.

THIS TRANSLATION IS A RENDITION OF THE ORIGINAL FOREIGN TEXT WITHOUT ANY ANALYTICAL OR EDITORIAL COMMENT. STATEMENTS OR THEORIES ADVOCATED OR IMPLIED ARE THOSE OF THE SOURCE AND DO NOT NECESSARILY REFLECT THE POSITION OR OPINION OF THE FOREIGN TECHNOLOGY DIVISION.

PREPARED BY:

TRANSLATION DIVISION
FOREIGN TECHNOLOGY DIVISION
WP.AFB, OHIO.

Table of Contents

U.S. Board on Geographic Names Transliteration System ii

The RKZ-3 Radiosonde of Increased Accuracy, by R.I. Bogdanov,
A.A. Vorontsov, Yu.A. Glagolev, B.P. Zaychikov, M.V. Krechmer,
G.P. Kalduzov, A.F. Kuzenkov, N.A. Kuz'micheva, V.I. Shlyakhov 2

Temperature Errors of Radiosonde RKZ-2 and Procedure of its
Operation, by O.V. Marfenko 20

Results of the Full-Scale Tests of New Thermal Units for the
Radiosonde RKZ-3, by P.F. Zaychikov, M.B. Fridzon 39

Aerological Radiosonde of the Type RKZ-5--2, by N.N. Grushin,
A.F. Kuzenkov, N.A. Kuz'micheva 49

DTIC
COPY
INSPECTED
2

| | |
|--------------------|-------------------------------------|
| Accession For | |
| DTIC CMA&I | <input checked="" type="checkbox"/> |
| DTIC T&B | <input type="checkbox"/> |
| Unannounced | <input type="checkbox"/> |
| Justification | |
| By | |
| Distribution/ | |
| Availability Codes | |
| Avail and/or | |
| Dist | Special |
| A | |

U. S. BOARD ON GEOGRAPHIC NAMES TRANSLITERATION SYSTEM

| Block | Italic | Transliteration | Block | Italic | Transliteration |
|-------|------------|-----------------|-------|------------|-----------------|
| А а | <i>А а</i> | A, a | Р р | <i>Р р</i> | R, r |
| Б б | <i>Б б</i> | B, b | С с | <i>С с</i> | S, s |
| В в | <i>В в</i> | V, v | Т т | <i>Т т</i> | T, t |
| Г г | <i>Г г</i> | G, g | У у | <i>У у</i> | U, u |
| Д д | <i>Д д</i> | D, d | Ф ф | <i>Ф ф</i> | F, f |
| Е е | <i>Е е</i> | Ye, ye; E, e* | Х х | <i>Х х</i> | Kh, kh |
| Ж ж | <i>Ж ж</i> | Zh, zh | Ц ц | <i>Ц ц</i> | Ts, ts |
| З з | <i>З з</i> | Z, z | Ч ч | <i>Ч ч</i> | Ch, ch |
| И и | <i>И и</i> | I, i | Ш ш | <i>Ш ш</i> | Sh, sh |
| Й й | <i>Й й</i> | Y, y | Щ щ | <i>Щ щ</i> | Shch, shch |
| К к | <i>К к</i> | K, k | Ъ ъ | <i>Ъ ъ</i> | " |
| Л л | <i>Л л</i> | L, l | Ы ы | <i>Ы ы</i> | Y, y |
| М м | <i>М м</i> | M, m | Ь ь | <i>Ь ь</i> | ' |
| Н н | <i>Н н</i> | N, n | Э э | <i>Э э</i> | E, e |
| О о | <i>О о</i> | O, o | Ю ю | <i>Ю ю</i> | Yu, yu |
| П п | <i>П п</i> | P, p | Я я | <i>Я я</i> | Ya, ya |

*ye initially, after vowels, and after ъ, ь; e elsewhere.
When written as ё in Russian, transliterate as yë or ë.

RUSSIAN AND ENGLISH TRIGONOMETRIC FUNCTIONS

| Russian | English | Russian | English | Russian | English |
|---------|---------|---------|---------|----------|--------------------|
| sin | sin | sh | sinh | arc sh | sinh ⁻¹ |
| cos | cos | ch | cosh | arc ch | cosh ⁻¹ |
| tg | tan | th | tanh | arc th | tanh ⁻¹ |
| ctg | cot | cth | coth | arc cth | coth ⁻¹ |
| sec | sec | sch | sech | arc sch | sech ⁻¹ |
| cosec | csc | csch | csch | arc csch | csch ⁻¹ |

Russian English

rot curl
lg log

GRAPHICS DISCLAIMER

All figures, graphics, tables, equations, etc. merged into this translation were extracted from the best quality copy available.

DOC = 82068201

PAGE 1

METHODS AND TECHNIQUES OF EXPERIMENTAL RESEARCH ON THE ATMOSPHERE.

Page 3.

THE RKZ-3 RADIOSONDE OF INCREASED ACCURACY

R. I. Bogdanov, A. A. Vorontsov, Yu. A. Glagolev, B. P. Zaychikov, M. V. Krechmer [deceased], G. P. Kalduzov, A. F. Kuzenkov, N. A. Kuz'micheva, V. I. Shlyakhov.

The PKZ-3 type radiosound was described. This radiosound had a higher accuracy and a smaller discreteness of the air temperature measurement than the other PKZ type radiosoundes of the. The standard chance errors of the air temperature individual reading obtained by the method of the pair radiosound flightings were less than ± 0.35 deg on the altitudes up to 40 km.

For measuring the parameters of state of free atmosphere in the aerological practice are utilized the devices/equipment of single action, which ensure the complex measurements (radiosondes). These instruments are intended, as a rule, for determining the value of three fundamental atmospheric parameters; temperature, pressure and air humidity at the heights/altitudes to 35 km. In this case the temperature of air is one of the most essential parameters. The results of temperature radiosounding moreover at present they are utilized for calculating the atmospheric pressure with the aid of the barometer formula. Pressure (during the use for measuring the height/altitude of station (Meteor) obtained thus proves to be at altitudes >5 km more precise than data of the direct radiosounding measurements of pressure [1].

To the measurements of the temperature of air in free-air conditions are presented high requirements. According to the requirements, formulated by world meteorological organization [1], in the range from 50 to -90°C the temperature must be measured with the error, which does not exceed 0.5°C . However, contemporary supply-line radiosondes possess high magnitudes of error, especially in the stratosphere. These errors are caused in essence by preheating temperature-sensitive element by short-wave and long-wave thermal radiation, by their own currents of metering circuits, by the effect of the entire risen system to the temperature-sensitive element, and also by the inertness of measuring elements/cells. The source of errors is also the insufficiently precise measurement of the state of temperature-sensitive element, caused by the effect of the destabilizing factors on the transformative circuits of radiosondes. Evaluation/estimate and account of these phenomena, for the purpose of the introduction of temperature corrections to readings/indications of concrete/specific/actual instrument are complex problem. It suffices to say that the root-mean-square random measuring error of the resistor/resistance of temperature-sensing devices, characteristic to the best supply-line radiosondes of domestic manufacture RKZ-2, it exceeds in the translation/conversion into temperature of 0.7°C .

Page 4.

In this case the difference between the readings and the actual temperature in the stratosphere at the height/altitude of 20-30 km reaches 5°C.

For increasing the accuracy of the measurement of temperature was developed radiosonde RKZ-3.

Radiosonde RKZ-3 is intended for the temperature-wind sounding of atmosphere in the especially critical aerological points/items of the country and for checking the accuracy of mass series radiosondes.

1. Description of instrument.

With the retention/preservation/maintaining of the known principles of conversion and transmission of meteorological data in the radiosondes of the type RKZ [2] the radiosounding device/equipment RKZ-3 (Fig. 1) structurally/constructurally differs from analogous type instruments.

For measuring the temperature in RKZ-3 is used new thermo-knot

with the bead temperature-sensing device STZ-25 and the optimum length of bracket in 30-40 cm [3].

The bead of thermal resistor STZ-25 has a diameter, equal to approximately/exemplarily 250μ and the platinum terminals with a diameter of 30μ at the length in 16 mm. Conclusions/outputs are soldered to the ends/leads of the plug from the silver-plated wire with a diameter of 1 mm whose foundation is fastened into the reinforced glass.

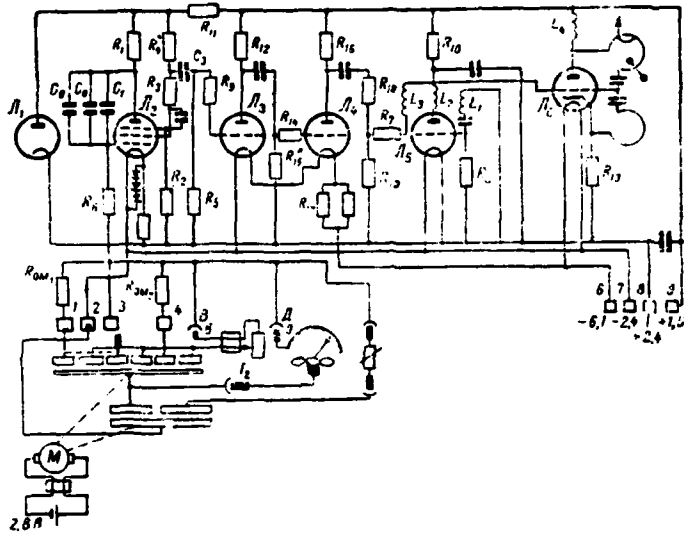

Fig. 1. Schematic diagram of radiosonde RKZ-3.

Page 5.

The stability of micro-thermal resistor STZ-25 in connection with its three-component structure and vitrification several times of higher than the two-component thermal resistors used earlier.

The thermal inertia of thermal resistor STZ-25 comprises not more than 0.4 s. The body of thermal resistor is covered/coated with anti-radiation coating - sulfate barium or special white paint.

For decreasing the errors, connected with the Joule warming of

temperature-sensing device, the power/thickness of the electric current of metering circuit is led to a value less than $100 \mu\text{W}$. A decrease in the power/thickness is achieved/reached by the selection of passive elements/cells and by decrease in the nominal anode voltage. The anodic and filament voltages of measuring generator-converter are stabilized (L_1).

This is the necessary measure with the work of the instrument in the temperature range of higher than 25°C (low values of the resistor/resistance of temperature-sensitive element).

The relation of the frequencies of signal generator, developed with the connection of thermal resistor and supporting/reference resistor/resistance R_1 , characterizes the state of temperature-sensing device.

For the control/checking of the safety of the calibration of radio-block in flight in diagram RKZ-3 are utilized two control resistors/resistances. This makes it possible to rate/estimate and to consider the effect of the destabilizing factors on the work of metering circuits in the process of the flight of radiosonde.

In order to restrict the effect of the subsequent cascades/stages of radio-block on the converter of the

resistor/resistance of sensors (L_1), and also for guaranteeing the possibility of replacing the transmitter without the subsequent calibrating of radio-block, are introduced two buffer stages of decoupling (L_2 and L_3).

In radiosonde RKZ-3 as the sensors of humidity and pressure can be used series tape/film hygrometer and aneroid capsule, used in the supply-line radiosondes RKZ [2]. The connection of sensors to the signal generator is realized with the aid of the commutator. The commutator of radiosonde RKZ-3 in contrast to the commutators, used usually in the foreign radiosondes or a commutator-pressure switch of radiosonde RKZ-1a, is carried out two-section. Its one section (lower in Fig. 1), in all to two positions, has a cycle of switching, equal to 11-16 s, the second (six positions) is designed for the cycle of switching 2.5-4 min.

In the lower section (Fig. 1) - two semirings, on the upper of six cuts of ring, moreover three of them wide (approximately/exemplarily on 85°), and three, as shown in Fig. 1, narrow (approximately/exemplarily on 25°).

Commutator works as follows. Radio-block continuously is converted into the spacing frequency in the radiation/emission of the transmitter of the value of the resistors/resistances, connected by

commutator at the given instant to the grid circuit of the converter between the supporting/reference resistor/resistance (Fig. 1) and supply of power - 2.4 V.

Page 6.

All sensors and supplementary supporting/reference resistors/resistances by their one conclusion are connected to the supporting/reference resistor/resistance. Their second conclusion/output commutator alternately connects to the battery of feed (-2.4 V).

To one of the contacts of the section of the short duration of cycle (to the right in Fig. 1) is connected the conclusion/output from the temperature-sensing device of radiosonde to another - the common point of section with the large duration of cycle. Three wide contacts of this section are connected together electrically and to them is connected the conclusion/output from the sensor of the humidity of radiosonde.

To three narrow contacts of this section through coupling 1 is connected the conclusion/output from supporting/reference resistor/resistance R_{0n1} , through coupling 4 - conclusion/output from resistor/resistance R_{0n2} and through coupling 3 - the fundamental

supporting/reference resistor/resistance R_0 . Upon the start of the motor of commutator every 10-16 s during 5-8 s to the converter is connected the temperature-sensing device, and second 5-8 s - sensor of humidity, pressure sensor or one of the supporting/reference resistors/resistances. In this case the radiosonde transmits the reference frequency of meteorological elements, the largest of all frequencies of the meteorological elements. The remaining part of the time temperature-sensing device is connected twice in 10-16 s.

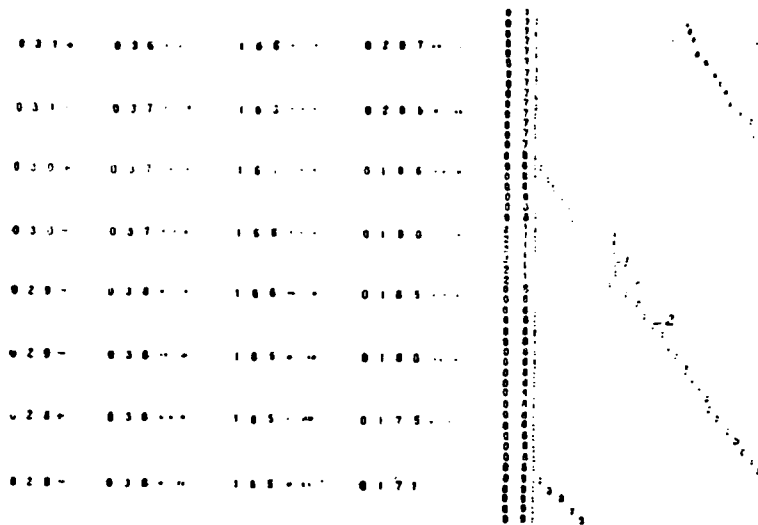

Fig. 2. Example of recording of data obtained with the aid of radiosonde RKZ-3. 1 - reference frequency, 2 - the frequency, which corresponds to temperature readings/indications.

Page 7.

Thus, commutator provides during entire flight of radiosonde the transmission of information about the temperature with the discreteness not more than 16 s, but the significant part of the time with the discreteness of calculation and press/printing 5 s, the transmission of information about the humidity commutator provides during 3/4 flight times (by intervals of time on 35-36 s), the breaks in the transmission of information about the humidity not exceeding

25 s. During these breaks are transmitted the signals of fundamental and supplementary reference frequencies (every 2.5-4.5 min on 15-25 s). The example of recording of data obtained from radiosonde RKZ-3 is given in Fig. 2.

The experimental models of radiosondes RKZ-3 underwent comparative tests with other radiosondes on the polygon/range of observatory in Ryl'sk.

2. Results of the studies of instrument.

Radiosondes RKZ-3 underwent laboratory and flight investigations for the accuracy of radio-blocks and telemetry in the control resistors/resistances. Were realized the comparisons of readings/indications RKZ-3 with the results, obtained with the aid of the radio-thermometer of pulse action with the wire temperature-sensing device and acoustic radio-thermometer, described earlier in works [4, 5].

Different types of tests underwent selectively approximately/exemplarily ten radiosondes RKZ-3.

The laboratory determinations of the root-mean-square values of the random measuring error of temperature due to the radio-block were

realized on the store of 15 precision resistors/resistances, evenly arranged/located in the range from 4.3 to 360 kilohm.

Tests showed that with the work with radiosonde RKZ-3 in the reasonably permissible limits of a change in the voltages of supply ($\pm 10\%$), supplied to the radio-block, the root-mean-square measuring error of resistors/resistances in the translation on the temperature does not exceed 0.35° in 80% of cases (in the absence of stabilization on the incandescence/filament). The minimum value of the root-mean-square measuring error of temperature composed 0.27°C . In this case the determination of the values of the high-impedance resistors/resistances, which correspond to the low temperatures in the atmosphere, is conducted with the larger accuracy, rather than low resistors/resistances. It turned out that voltage regulation of the incandescence/filament of the signal generator of radiosonde is reasonable measure. With a change in the filament voltage/stress within limits of $\pm 10\%$ reference frequency is changed on the average on 40-50 Hz, which indicates the insufficiently deep stabilization of the filament voltage/stress (this deficiency/lack is in prospect to correct during the preparation of instruments for the series production).

The displacement of the graph/curve of the check/verification of radiosonde RKZ-3 according to the temperature due to a temporary/time

change of the characteristics of radio-block on the average in 15 points (storage time of probes approximately one year) did not exceed 0.3°C in 80o/o of cases.

As showed the materials of flight tests, temperature data of radiosonde RKZ-3 possess sufficiently high reproducibility (Table 1).

Page 8.

The root-mean-square value of the random error in determination of temperature by radiosonde RKZ-3, obtained by the method of the paired issues, without the introduction of any corrections, did not exceed 0.35°C . In 60o/o of cases the rms error did not exceed the limits of 0.25°C .

As a rule, the divergences of control resistors/resistances from the rating, advanced on the calibration graph/curve, did not exceed in the process of the flight of radiosonde of $0.2-0.3^{\circ}\text{C}$ (in the translation to the temperature). However, in certain cases the divergence of control resistors/resistances reaches 1.0°C . The introduction of the control resistors/resistances provides the rejection of false data (it is sufficient large temperature disagreements), which are the result of acting the destabilizing factors (Table 1).

The comparison of radiosonde RKZ-3 with the wire and acoustic radio-thermometers showed that overheating the thermal resistor of radiosonde RKZ-3 with respect to the sensors of the instruments indicated under the most unfavorable daytime working conditions in the atmosphere does not exceed 2.6°C , from which 1.5°C are caused by overheating by the measuring current of circuit.

The averaged results of these comparisons are given in Table 2.

Table 1. Average/mean systematic differences ΔT , the root-mean-square values of random differences σ and a number of cases in layers n for the pairs of radiosondes RKZ-3—RKZ-3 and after the introduction of corrections for control resistors/resistances ($\Delta T_{исп}$)

| (2) Дата и время выпуска | (3) Величины | (1) Слой осреднения, мб | | | | | | |
|--------------------------------|------------------|-------------------------|-------------|-------------|------------|-----------|-----------|-----------|
| | | (4) Земля— 600 | 600— 300 | 300— 160 | 160— 80 | 80— 40 | 40— 20 | 20— 10 |
| 24 VII 1968 10 час(5) | ΔT | 0,2 | -0,1 | | 0,0 | 0,2 | -0,2 | |
| | $\Delta T_{исп}$ | 0,2 | 0,4 | | -0,1 | 0,0 | -0,3 | |
| | σ | 0,47 | 0,41 | | 0,32 | 0,42 | 0,32 | |
| | n | 14 | 16 | | 13 | 14 | 7 | |
| 26 VII 1968 10 час(5) | ΔT | -0,3 | -0,3 | -0,7 | -0,8 | -0,9 | -0,8 | 0,7 |
| | $\Delta T_{исп}$ | -0,5 | -0,3 | -0,4 | -0,4 | -0,5 | -0,4 | -0,1 |
| | σ | 0,29 | 0,30 | 0,21 | 0,23 | 0,20 | 0,32 | 0,32 |
| | n | 16 | 19 | 15 | 15 | 14 | 17 | 9 |
| 26 VII 1968 21 час(5) | ΔT | -0,9 | -0,4 | 0,2 | 0,3 | 0,1 | 0,0 | |
| | $\Delta T_{исп}$ | -1,0 | -0,2 | 0,5 | 0,0 | -0,7 | 0,0 | |
| | σ | 0,29 | 0,43 | 0,37 | 0,24 | 0,0 | 0,20 | |
| | n | 13 | 19 | 15 | 15 | 14 | 24 | |
| 30 VII 1968 21 час(5) | ΔT | 0,4 | 0,8 | 0,3 | 0,0 | -0,1 | | |
| | $\Delta T_{исп}$ | 0,7 | 0,7 | 0,4 | 0,0 | 0,0 | | |
| | σ | 0,67 | 0,50 | 0,34 | 0,41 | 0,22 | | |
| | n | 17 | 18 | 10 | 9 | 19 | | |
| (6) Среденные величины | ΔT | 0,4 | 0,4 | 0,4 | 0,3 | 0,3 | 0,5 | 0,7 |
| | $\Delta T_{исп}$ | 0,6 | 0,4 | 0,4 | 0,1 | 0,3 | 0,3 | 0,1 |
| | σ | 0,49 | 0,48 | 0,32 | 0,30 | 0,21 | 0,28 | 0,32 |

Key: (1). Layer of averaging, mb. (2). Date and time of issue. (3). Values. (4). Earth. (5). hour. (6). Averaged values.

Page 9.

The bead thermal resistor STZ-25 used as the temperature-sensing device possesses sufficiently high stability. The small diameter of bead and the rational diameter of the wire of electrical leads, the use of anti-radiation coating, the design features of thermo-knot

provide, radiation overheating small, in comparison with other types of radiosondes of temperature-sensing device. Investigations [6] conducted earlier showed that the radiation overheating of bead to the height/altitude of 40 km is less than 2°C.

The results of investigation, given in [6], make it possible to introduce correction to the temperature readings for overheating of temperature-sensitive element by radiation and by measuring currents.

Let us point out that in the paired daytime radiosonde ballooning RKZ-3 and RKZ-2 the temperature readings/indications of radiosonde RKZ-3 at altitudes >20 km were below the values, obtained with the aid of radiosonde RKZ-2 (sometimes to 2.6°C).

Thus the results of investigations show that radiosonde RKZ-3 possesses the considerably higher accuracy of the measurement of free-air temperature, the supply-line the radiosondes RKZ-2 and A-22. With the advent of RKZ-3 prove to be possible the organization of the base net of aerological stations, and also the periodic inspection of the accuracy of supply-line radiosondes of another type under the actual conditions for flight.

Received 12 December 1968.

Table 2. Averaged results of the daytime comparisons of radiosonde RKZ-3 (without the introduction of thermal corrections) acoustic thermometer and bridge type radio-thermometer (T - radioacoustic thermometer - T radiosonde RKZ-3).

| | (1) Слой осреднения, мб | | | | | | |
|---------------------------------|-------------------------|---------|---------|--------|-------|-------|-------|
| | 0-600 | 600-300 | 300-160 | 160-80 | 80-40 | 40-20 | 20-10 |
| (2) Радиоакустический | | | | | | | |
| (3) Средняя разность температур | -0,1 | -1,2 | -1,5 | -1,7 | -1,7 | -2,6 | |
| (4) Число выпусков | 1 | 2 | 3 | 3 | 3 | 2 | |
| (5) Число отсчетов | 17 | 16 | 31 | 34 | 19 | 29 | |
| (6) Мостовой | | | | | | | |
| (3) Средняя разность температур | -1,2 | -1,24 | -0,86 | -0,80 | -0,60 | -0,76 | |
| (4) Число выпусков | 4 | 4 | 3 | 3 | 3 | 3 | |
| (5) Число отсчетов | 115 | 143 | 84 | 82 | 77 | 71 | |

Key: (1). Layer of averaging, mb. (2). Radioacoustic. (3). Average/mean difference in temperatures. (4). Number of issues. (5). Number of readings. (6). Bridge.

Page 10.

REFERENCES

1. Шляхов В. И. Состояние и перспективы развития температурно-ветрового и специального зондирования. Труды ЦАО, вып. 90, 1969, 5—16.
2. Хахалкин В. С. Современные радиозонды. Госэнергоиздат, 1959.
3. Арбузова В. Н., Глаголев Ю. А., Кречмер М. В., Тормоз Л. Ф. Результаты экспериментального исследования зависимости точности измерения температуры воздуха от параметров терморезистора и термоузла радиозонда. Метеорология и гидрология, № 2, 1968.
4. Юрчук В. А. Мостовые схемы с импульсным питанием как преобразователь аналог-код в телеметрических системах. Труды ГМЦ, вып. 16, 1966, 65—74.
5. Мордухович М. И. Локальный акустический метод измерения температуры воздуха. Изв. АН СССР, сер. геофизическая, № 3, 1959, 480—488.
6. Глаголев Ю. А. Теоретическая оценка оптимальных параметров бусниковых терморезисторов для радиозондов. Труды ЦАО, вып. 84, 1969, 38—49.

Page 11.

TEMPERATURE ERRORS OF RADIOSONDE RKZ-2 AND PROCEDURE OF ITS
OPERATION.

O. V. Marfenko.

The results of the investigation of the radiosonde PKZ-2 type temperature errors are described in this paper. Some methods of the radiosonde verification are given

For solving the series/row of the systematic questions, which appear during the operation of radiosonde, it is not enough to know the value of its resultant error concerning the measured element/cell. The components of this error have different value and origin, which causes different methods of their determination and possibility of account under the conditions for standard observations at the aerological stations. For the solution of latter/last problem into 1967-1968 was conducted the investigation of the measuring error of temperature by radiosonde RKZ-2.

The measuring error of temperature by a radiosonde of the type

RKZ is composed of the error, introduced by thermal resistor, and the error, introduced by radio-block. We investigated the fundamental error, introduced by radio-block, understanding under this error reproducibility of readings/indications of radio-block under normal conditions (room temperature, surface pressure, the nominal rating of the feed: $U_n = 2.4 \text{ V}$, $U_a = 195 \text{ V}$, $U_n = 6.1 \text{ V}$ respectively), and the supplementary error, which appears with the deviation of the mode of feeding of radio-block to the maximum permissible values. For the purpose of the determination of the period of the fitness/suitability of radiosonde was investigated a change of readings/indications of radiosonde in the time.

The fundamental error of radio-block have determined we via the comparison of the given repeated checks/verifications of the radio-blocks through the short time intervals with direct/constant reeding voltages (nominal and deflecting from it to 8-10o/o). Check/verification was conducted with the aid of the assembly of monitoring-measuring equipment (KIPAS-1).

Page 12.

Table 1 gives the average/mean absolute $\left(\overline{\Delta t} = \frac{\sum_{i=1}^n \Delta t_i}{n} \right)$ and arithmetic mean $\left(\overline{\Delta t} = \frac{\sum_{i=1}^n \Delta t_i}{n} \right)$ values of differences in the repeated checks/verifications of 20 radio-blocks of radiosonde RKZ-2 at 15

steps/stages of the checks/verifications, expressed in the degrees. In the input information of Table 1 are given the values of the resistors/resistances measured by radio-block, the checks/verifications corresponding to steps/stages, and the approximate values of temperature, which correspond to the values of the resistor/resistance of thermal resistor MMT-1 indicated. Data are acquired during the nominal rating of feed. Equality to zero arithmetic mean values of differences testifies about the sufficiency of the series/row of measurements for obtaining the reliable data about the value of error. The average quadratic value of the fundamental measuring error of the temperature of lower than calculated according to given data 0° , introduced by radio-block, does not exceed 0.1° . Higher temperature is measured with the larger error, reaching $0.6-0.7^\circ$ at a temperature of $20-40^\circ\text{C}$.

The defining by component fundamental error of radio-block, as it seemed, is the error, which depends on the sensitivity of radiosonde. The measuring error of temperature, which depends on the sensitivity of radiosonde, is determined in the extreme case by the value

$$\Delta y = \frac{\Delta F_t F_{on} + \Delta F_{on} F_t}{F_{on}^2},$$

where $\Delta F_t = \Delta F_{on} = 1$ Hz - discreteness of the measurement of frequency, $F_{on} \approx 2000$ Hz, F_t - it varies within the limits of $50-1950$ Hz.

The values of errors, which correspond to values Δy for different temperature ranges, are given in the latter/last row Table 1. They proved to be approximately/exemplarily they were equal to the values of fundamental error. This fact has a value during the solution of a question about the decrease of frequency band for transmission of information about the meteorological data, i.e., about the decrease of the sensitivity of the radiosonde: the decrease of sensitivity virtually in so many once will increase the random error, introduced into the measurement of meteorological element by radio-block.

Table 1. Average/mean differences in readings/indications of radio-blocks RKZ-2 through the short time intervals (deg).

| | No. of steps/stages (1) | | | | | | | | | | | | | | |
|---------------------------|-------------------------|------|------|------|------|------|------|------|------|------|------|------|------|------|------|
| | 1 | 2 | 3 | 4 | 5 | 6 | 7 | 8 | 9 | 10 | 11 | 12 | 13 | 14 | 15 |
| Range (2) | 4.3 | 5.6 | 7.6 | 11 | 15 | 20 | 26 | 37 | 52 | 82 | 110 | 150 | 200 | 250 | 300 |
| Δt | 50 | 40 | 25 | 15 | 5 | 15 | 23 | 31 | 35 | 44 | 50 | 55 | 65 | 70 | 75 |
| ΔT | -0.03 | -0.1 | 0.02 | 0.01 | 0.02 | 0.05 | 0.03 | 0.02 | 0.02 | 0.02 | 0.02 | 0.02 | 0.01 | 0.01 | 0.01 |
| ΔT | 0.44 | 0.21 | 0.27 | 0.19 | 0.12 | 0.12 | 0.08 | 0.09 | 0.06 | 0.04 | 0.02 | 0.01 | 0.02 | 0.01 | 0.01 |
| Number of cases (3) | 10 | 20 | 20 | 20 | 20 | 20 | 20 | 20 | 20 | 20 | 20 | 20 | 20 | 20 | 20 |
| Δy (deg/0.0005°C) | 0.37 | 0.26 | 0.26 | 0.15 | 0.10 | 0.10 | 0.09 | 0.08 | 0.07 | 0.06 | 0.09 | 0.10 | 0.11 | 0.12 | 0.11 |

Key: (1). No of the step/stage of check/verification. (2). kiloohm. (3). Number of cases. (4). Δy deg/0.0005°C.

Page 13.

The significant error into the measurement of temperature and humidity of air by radiosonde RKZ introduces the dependence of output data of radio-block, of the carrying information about the meteorological elements, on the voltages feeding batteries.

Previously conducted investigations [1] showed that this error is systematic for the separate radiosonde: constant with respect to the value and the sign the divergence of the feeding voltage/stress from the nominal value causes the constant error in the measurement of meteorological element. The value of error for this voltage error varies from one radiosonde to the next, being subordinated to the

normal law of distribution, and it is determined by the diagram of radio-block and by the quality of its tuning. The sign of error is determined by the sign of voltage error: increase in the filament voltage/stress 2.4 V or lowering the anodic leads to the understating of the actual temperature of air, and vice versa. The greatest effect on a change in readings/indications of radio-block exerts filament voltage/stress 2.4 V. For the radiosonde RKZ-2 are obtained the following average values of the measuring errors of temperature with a change in the mode of feeding of radio-block to the maximum permissible values.

| | | | | | |
|----------|-------------|------------------|-----------------|---------------------|---------------|
| В режиме | $U_a = 212$ | $\sigma_a^{(1)}$ | $U_{an} = 2,65$ | $\sigma_{an}^{(1)}$ | $+0,25^\circ$ |
| > | $U_a = 178$ | $\sigma_a^{(2)}$ | $U_{an} = 2,15$ | $\sigma_{an}^{(2)}$ | $-0,20^\circ$ |
| > | $U_a = 212$ | $\sigma_a^{(2)}$ | $U_{an} = 2,15$ | $\sigma_{an}^{(2)}$ | $-0,40^\circ$ |
| > | $U_a = 178$ | $\sigma_a^{(1)}$ | $U_{an} = 2,65$ | $\sigma_{an}^{(1)}$ | $+0,30^\circ$ |

Key: (1). In the mode/conditions. (2). V.

It is noted that the value of error, average for this batch of radiosondes during the assigned feed mode, expressed in the degrees, is identical at all steps/stages of the check/verification of radiosondes, i.e., for entire range of the measured temperature. From the point of view of effect to the accuracy of radiosonde most dangerous proves to be lowering the feeding voltage/stress and especially filament 2.4 V.

Flashover characteristics of batteries 200 PMKhM-2ch on the

anode and the incandescence/filament 2.4 V are given in Fig. 1 and 2.

Page 14.

These curves are obtained in the thermobaric chamber on the equivalent to radio-block load after the preliminary formation of batteries to minimum operating voltages/stresses ($U_{n1} = 2.15$ V, $U_{n2} = 3.5$ V, $U_{n3} = 178$ V) and discharge at surface pressure during 10 min at a temperature of $+25^{\circ}\text{C}$ and 5 min at a temperature of -40°C . The conditions for the work of battery with 15th min, which was accepted for the beginning of the useful work of battery ($r=0$), were given in Table 2.

This procedure of the preparation of the batteries before beginning tests corresponds to the conditions for their operation.

In the lower field Fig. 1 and 2 are given the discharge curves of the separate batteries of individual batches, on the upper - average/mean curves for the batteries of 14 different batches.

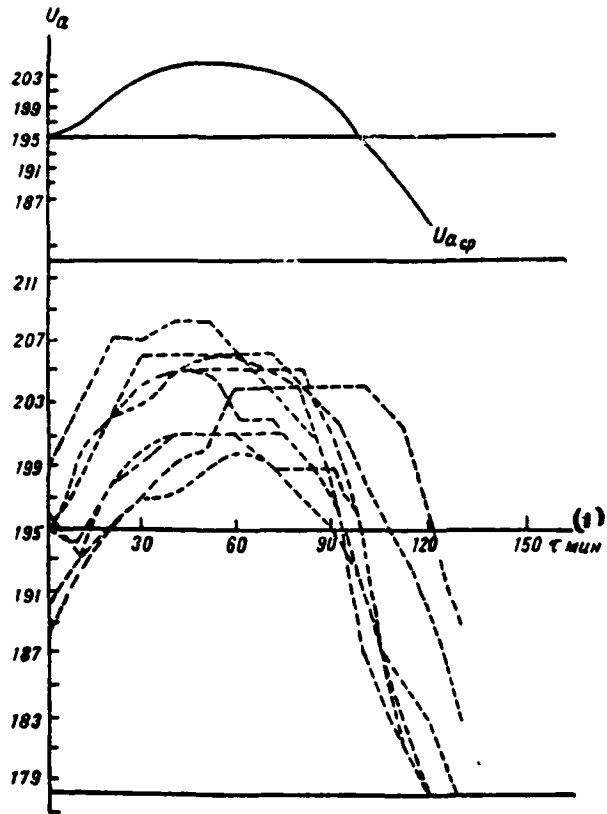

Fig. 1. Flashover characteristics of the anodic section of battery 200PMKhM-2ch.

Key: (1). min.

Page 15.

Characteristic for the filament section of battery is the rapid

reaching/achievement of voltage/stress maximum for this battery, its retention/preservation/maintaining during approximately/exemplarily 90 min, and then rapid incidence/drop. For the anodic section the characteristically rapid reaching/achievement of minimum voltage/stress during the formation, slow increase/growth during 50-60 min of up to the maximum value, then during 30-35 min the slow and, only then, rapid incidence/drop. A rapid increase in the voltage into the first minutes of the useful work of battery is explained by the special features/peculiarities of experiment. The fact is that the anodic section with the formation achieved minimum operating voltage/stress much more rapid than filament, and it disconnected. In the first minutes of the discharge in the operational conditions anodic section actually was deformed.

Findings give grounds to consider the mode of feeding of radio-block during the separate sounding sufficiently to stable ones, and the measuring errors of meteorological element under the conditions of sounding the atmosphere, which appear with its divergence from the nominal, systematic.

Table 2. Conditions of the discharge of battery 200PMKhM-2ch.

| | Время, мин (1) | | | | | | | |
|----------------------|----------------|-----|-----|-----|-----|-----|-----|-----|
| | 0 | 15 | 30 | 45 | 60 | 90 | 105 | 120 |
| $P, \text{мВ}^{(2)}$ | 970 | 700 | 460 | 250 | 130 | 25 | 5 | 5 |
| $t, ^\circ\text{C}$ | -40 | -44 | -47 | -50 | -52 | -52 | -52 | -52 |

Key: (1). Time, min.

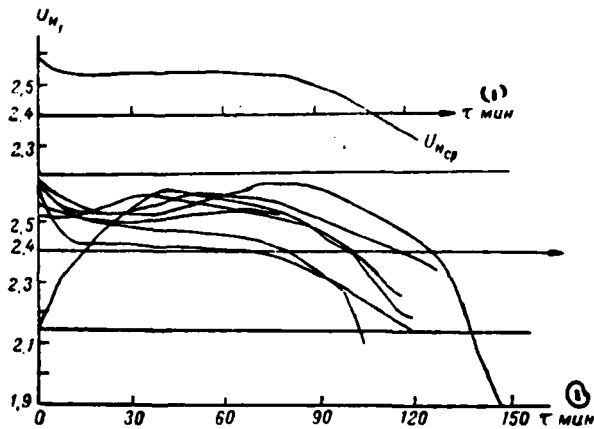

Fig. 2. Flashover characteristics of filament section of battery 200PMKhM-2ch.

Key: (1). min.

Page 16.

Focuses attention the fact that the nominal rating of the feed of radio-block RKZ does not correspond to the medium

voltages/stresses, put out by batteries 200PMKhM-2ch: $\bar{U}_{u_1} = 2.5$, $\bar{U}_s = 200$ V. The data about the fact that the medium voltages/stresses, put out by batteries 200PMKhM-2ch, and under the actual conditions for sounding, as a rule, higher than nominal, are confirmed by the values of the reference frequencies of the radiosonde in flight and by the values of variations during the control check/verification of radio-blocks at the aerological stations.

For the procedure of the operation of radiosonde it is important to know the stability of its calibration data in time. Moreover, it is important to know not only values, but also character of a change in readings/indications of radiosonde in the course of time. So if calibration curve in the course of time is displaced by in parallel initial plant curve, sufficiently control reading in order to determine correction to calibration data, constant for entire range of the measured element/cell.

The results of the study of a change in readings/indications of the radio-blocks of radiosonde RKZ-2 in the course of time are given in Table 3. Observations they conducted after 15 radio-blocks, undertaken from different batches. Table 3 gives arithmetic mean and average/mean absolute differences in readings/indications of radio-blocks during the plant calibration and through 1, 12, 24, 30 and 33 months. Findings do not indicate the presence of any regular

DOC = 82068202

PAGE 31

changes in readings/indications of radio-blocks in the course of time. Is not noted also increase with the time of the absolute values of differences. Average absolute amount of deflection at the steps/stages of the 5th and no longer exceeds 0.4° .

Table 3. Change (deg) in readings/indications of radio-blocks RKZ-2 in the course of time.

| Дата и место наблюдения (1) | Характеристика ошибки (2) | Сумма (3) | | | | | | | | | | | | | | |
|-----------------------------|----------------------------|-----------|-------|-------|-------|-------|-------|-------|-------|-------|-------|-------|-------|-------|-------|--|
| | | 3 | 5 | 6 | 8 | 8 | 7 | 8 | 9 | 10 | 10 | 12 | 13 | 14 | 15 | |
| 1 | Среднее арифметическое (4) | 0.46 | 0.42 | 0.25 | 0.14 | 0.14 | -0.02 | -0.04 | -0.02 | -0.06 | -0.12 | -0.20 | -0.06 | 0.00 | -0.04 | |
| | Среднее абсолютное (5) | 0.46 | 0.46 | 0.22 | 0.12 | 0.30 | 0.05 | 0.12 | 0.16 | 0.14 | 0.18 | 0.16 | 0.07 | 0.20 | 0.02 | |
| 12 | Среднее арифметическое (4) | 0.14 | 0.18 | 0.12 | -0.12 | -0.15 | -0.13 | -0.09 | -0.12 | -0.22 | -0.18 | -0.11 | -0.16 | -0.19 | -0.13 | |
| | Среднее абсолютное (5) | 0.37 | 0.28 | 0.31 | 0.28 | 0.30 | 0.31 | 0.32 | 0.31 | 0.37 | 0.35 | 0.38 | 0.32 | 0.30 | 0.29 | |
| 24 | Среднее арифметическое (4) | 0.22 | 0.28 | 0.00 | 0.05 | 0.05 | 0.12 | 0.13 | 0.15 | 0.08 | 0.13 | 0.20 | 0.20 | 0.22 | 0.18 | |
| | Среднее абсолютное (5) | 0.43 | 0.29 | 0.30 | 0.25 | 0.32 | 0.29 | 0.28 | 0.25 | 0.27 | 0.25 | 0.18 | 0.18 | 0.21 | 0.25 | |
| 30 | Среднее арифметическое (4) | -0.17 | -0.11 | -0.26 | -0.27 | -0.31 | -0.23 | -0.21 | -0.28 | -0.38 | -0.31 | -0.25 | -0.12 | -0.27 | -0.20 | |
| | Среднее абсолютное (5) | 0.37 | 0.31 | 0.28 | 0.23 | 0.28 | 0.21 | 0.21 | 0.21 | 0.22 | 0.27 | 0.23 | 0.24 | 0.25 | 0.23 | |
| 33 | Среднее арифметическое (4) | 0.8 | 0.65 | -0.12 | -0.18 | -0.15 | -0.08 | -0.02 | -0.05 | -0.08 | -0.03 | -0.03 | -0.09 | -0.05 | -0.02 | |
| | Среднее абсолютное (5) | 0.37 | 0.28 | 0.31 | 0.18 | 0.17 | 0.14 | 0.14 | 0.17 | 0.22 | 0.19 | 0.21 | 0.20 | 0.18 | 0.18 | |

Key: (1). Duration of storage, month. (2). Characteristic of error. (3). Steps/stages. (4). Arithmetic mean. (5). Average/mean absolute.

Page 17.

Changes in readings/indications of separate radio-blocks are different: in some new calibration curve is displaced in parallel to plant, in others its inclination/slope changed (changed sensitivity), sometimes the points of control check/verification are randomly scattered by relatively plant curve. This character of differences in readings/indications of radio-blocks makes it possible to assert that they are the consequence of the errors either of plant or control calibration with the aid of KIPAS-1. Ageing calibration data of radiosonde, at least for three summers/years, does not occur.

The results of the study of the errors of radiosondes of the type RKZ indicate the need for examining two aspects of a question of the accuracy of radiosonde. The first - accuracy of a radiosonde of this type, knowledge by which is necessary for the evaluation of the accuracy of aerological information. Is determined this accuracy by statistical methods according to the data of the tests of many radiosondes of this type under the laboratory or flight conditions. Second aspect - conformity to the accuracy of separate radiosonde to the requirements of accuracy, presented to the radiosondes of this type, in other words, the determination of the fitness/suitability of radiosonde for the sounding.

Under the conditions of the carrying out at the plant and of operational work at the aerological stations the statistical methods of determining even random errors are barely suitable. More advisable it is, knowing the statistical characteristics of the random errors of a radiosonde of this type, to establish/install criteria for the permissible value of the error of separate radiosonde. As the criterion for the evaluation/estimate of fitness/suitability for sounding the separate radiosonde to us it is considered advisable to take value 2σ whose confidence coefficient is equal to 95o/o. Value σ is determined according to the data of the study of many

radiosondes. In this case is completely compulsory separate determination and evaluation/estimate of the errors of random ones and errors of systematic ones for the separate radiosonde.

Page 18.

The total root-mean-square error, introduced by the radio-block of radiosonde RKZ-2, the characteristic accuracy of this radiosonde, are equal to

$$\sigma_{\text{p. b.}} = \sqrt{\sigma_1^2 + \sigma_2^2 + \sigma_3^2} \\ = \sqrt{0,1^2 + 0,15^2 + 0,15^2} = 0,23\%$$

Here σ_1 - rms value of the fundamental random error, introduced by radio-block; σ_2 - rms value of error, introduced by radio-block at the value of the anode voltage 200 V, filament 2.5 V; σ_3 - rms value of error, introduced by the procedure of the check/verification of radio-block. The total random measuring error of temperature by a radiosonde of the type RKZ-2 is equal to vector sum of the errors of radio-block and errors of the thermal resistor:

$$\sigma_{\text{cym}} = \sqrt{\sigma_{\text{p. b.}}^2 + \sigma_4^2} = \sqrt{0,23^2 + 0,4^2} = 0,46\%$$

This value of error is confirmed by the paired radiosonde ballooning [2]. The data about the errors of thermal resistor we obtained, analyzing the results of the study of the stability of thermal resistors MMT-1, carried out in bureaus of the check/verification of TsAO [Central Aerological Observatory]

in 1961. It is obtained that on the average due to a change in calibration data of thermal resistor in 3-12 months the radiosonde understates the temperature of air on $0.15-0.25^{\circ}\text{C}$ with the divergence from the average at the separate steps/stages of check/verification of $\pm 0.2^{\circ}$. Thus, systematic component of the value of a change in calibration data of thermal resistor in the course of time is approximately/exemplarily equal to the random error of thermal resistor, that it does not make it possible to determine it on the single control reading. The average absolute value of a change in calibration data of thermal resistor according to the data of control checks/verifications at the aerological stations is somewhat more than according to the data of special laboratory investigations, and it is equal to 0.4° . In all probability, this is explained by the incorrectness of the procedure of the control check/verification of thermal resistor in the ventilation cabin.

During the evaluation/estimate of fitness/suitability according to the precision characteristics of each separate radiosonde it is necessary, as has already been spoken, to separately rate/estimate the random error, introduced by radio-block, and the systematic error, which appears with a change in the feed mode to the maximum permissible values.

Random error is evaluated according to a difference in two

consecutive calibrations of radio-block during the constant duty of feed. Value 2σ whose excess must be reason for the rejection of radio-block, is normalized separately for each step/stage of check/verification. According to our data, it is equal at 2nd step/stage of 0.8° , on the 3rd of 0.25° at 4th step/stage of 0.2° , with the 5th on the 13th - 0.1° , on the 14th and the 15th - 0.15°C .

The evaluation/estimate of the error, introduced by radio-block RKZ with a change in the feeding voltages/stresses, it is expedient to produce according to the data of control readings in the range where the random error of radio-block is small. In this case there is no need in the large series/row of measurements.

Page 19.

It is sufficient two control readings, for example on the 6th (20 kilohm) and 13th (200 kilohm) points of check/verification so that the maximum error of average would not exceed 0.2° .

Check/verification it suffices to produce in two most unfavorable modes/conditions: 1) $U_a = 212 \text{ V}$, $U_n = 2,15 \text{ V}$. (+A, -H); 2)

$U_a = 178 \text{ V}$, $U_n = 2,65 \text{ V}$, (-A, +H). By criterion for the rejection of radio-block under the value of a difference in readings/indications of radio-block during the nominal rating and the conditions +A-H or -A+H to 6- or the 13th steps/stages is the sum of

the doubled root-mean-square value of fundamental error and doubled root-mean-square value of the error of radiosonde RKZ-2 during the feed mode indicated. This value, according to our data, is equal to 1.2°C.

For the conditions of aerological stations, upon consideration of the supplementary error, introduced by the monitoring-measuring equipment of the smaller class of precision, than plant, the criterion must be somewhat greater.

The obtained results are allowed, furthermore, to raise a question about a change in the nominal rating of the feed of radiosonde and an increase in the period of its fitness/suitability for the sounding at least of up to three years. The introduction of corrections to calibration data of radiosonde according to the data of control check/verification for the aerological stations is at present inexpedient. Several decrease the systematic measuring error of the temperature in the separate sounding can the introduction of the correction, which considers the values of voltages/stresses, put out by the battery 200PMKhM-2ch, with which the radiosonde is produced in the flight. However, we did not succeed in obtaining the more accurate results of sounding, after processing the paired radiosonde ballooning RKZ-2 with the introduction of corrections to calibration data of the radio-blocks, obtained according to the data

of control readings for steps/stages 20 and 200 killohm with the feed from the battery. Accuracy did not increase also with the introduction of corrections to calibration data of the thermal resistors, obtained by the comparison of readings/indications of the temperature by radiosonde and by aspiration psychrometer in the ventilation cabin.

The author expresses deep gratitude to L. F. Akopova, L. P. Brovina and K. I. Gol'tsova, who carried out experiments.

Submitted 18 Mar. 1969.

REFERENCES

1. Марфенко О. В., Маркелова К. П. Результаты исследования влияния напряжения источников питания на измерение температуры радиозондом РКЗ-1А. Труды ЦАО, вып. 74, 1966, 23—31.
2. Марфенко О. В. Оценка точности результатов зондирования на аэрологической сети Советского Союза. Метеорология и гидрология, № 3, 1969, 14—25.

Page 20.

RESULTS OF THE FULL-SCALE TESTS OF NEW THERMAL UNITS FOR THE
RADIOSONDE RKZ-3.

P. F. Zaychikov, M. B. Fridzon.

The results of the experimental investigations of some radiosond PKZ 2 type
thermometer modifications are given

At present the thermal unit of radiosonde RKZ-2 is the brass silver-plated framework to which is fastened/strengthened thermal resistor MMT-1, covered with nitroenamel NTs-25. For the purpose of a decrease in the radiation measuring errors in works [1, 2] it was proposed to replace the brass framework of Manganin and entire thermal unit to cover/coat with the special anti-radiation enamel VL-548. Coating of thermal unit with enamel VL-548, as shown in [2], must lower overheating thermal resistor MMT-1 by short-wave radiation, and the use of the Manganin framework decreases the heat flux on the conductors to the thermal resistor from the housing of instrument and other structural parts.

For checking these positions in the laboratory of the

check/verification of TsAO [Central Aerological Observatory] in 1967 were carried out the tests, which showed the noticeable advantages of the Manganin framework, covered with enamel VL-548, in comparison with the plant thermal unit.

Thermal units were investigated in the ventilation pressure chamber at the rate of blowout $W=6$ m/s and the solar irradiation with an intensity of $I_s=1.0$ cal/cm²min. The results of tests are represented in Table 1.

As we see from the data of Table 1, the radiation overheating of new thermal units is five times lower than standard ones.

Table 1. Value of overheating of thermal units ($^{\circ}\text{C}$) depending on the degree of rarefaction/evacuation ($I_0=1 \text{ cal/cm}^2\text{min}$, $W=6 \text{ m/s}$).

| (1) Р. мм | (2) Стандартный термоузел | (3) Стандартный термоузел без изоляционной фишки. целиком покрытый ВЛ-548 | (4) Манганиновая рамка $\varnothing 0.5 \text{ мм}$. $l=85 \text{ мм}$. целиком покрытая ВЛ-548 |
|--------------|------------------------------|--|--|
| 1000 | 0,5 | — | — |
| 100 | — | 0,8 | 0,4 |
| 10 | 5,1 | 2,3 | 1,1 |
| 1 | 7,5 | 3,4 | 1,5 |

Key: (1). mm. (2). Standard thermal unit. (3). Standard thermal unit without insulating plug, wholly covered VL-548. (4). Manganin framework of $\varnothing 0.5 \text{ mm}$, $l=85 \text{ mm}$, wholly covered VL-548.

Page 21.

During August-September of 1969 in the actual conditions were carried out the flight tests of different modifications of thermal units prepared at the Sverdlovsk plant of hydrometeorological instruments.

In all in the tests participated four types of the thermal units:

| (a) № модификации | (b) Краткая характеристика |
|----------------------|--|
| 1 | Заводской стандартный термоузел радиозонда РКЗ-2 |
| 2 | Заводская рамка без верхней изоляционной фишки, целиком покрытая эмалью ВЛ-548 |
| 3 | Манганиновая треугольная рамка (диаметр 0,5 мм, длина стороны 85 мм), целиком покрытая эмалью ВЛ-548 |
| 4 | Заводской стандартный термоузел радиозонда РКЗ-2, целиком покрытый эмалью ВЛ-548 |

Key: (a). No. of modification. (b). Short characteristic. (1). Plant standard thermal unit of radiosonde RKZ-2. (2). Plant framework without upper insulating plug, wholly covered with enamel VL-548. (3). Manganin triangular framework (diameter of 0.5 mm, length of side 85 mm), wholly covered with enamel VL-548. (4). Plant standard thermal unit of radiosonde RKZ-2, wholly covered with enamel VL-548.

All four modifications of thermal units were placed on the housing of one radiosonde. The commutation of sensors and supporting/reference resistor/resistance was realized with the aid of the switch ARZ of TsAO.

Were produced eight radiosonde ballooning (two in the night time). In the daytime radiosonde ballooning were conducted about 11 hours, and at night about 23 hours on Moscow time.

Table 2 gives average/mean differences in readings/indications of these thermal units and standard deviations of single measurements

from the thermal units average/mean in the five-kilometer layers for the appropriate six pairs of modifications: 2-1, 3-1, 4-1, 2-3, 2-4 and 3-4. Confidence intervals with probability 0.99 in all cases do not exceed $\pm 0.2^{\circ}\text{C}$. From the represented six pairs of differences three pairs make it possible unambiguously to judge the reason, which caused the appropriate difference in the temperature. For example, difference of pair 4-1 is caused only by the effect of coating. A difference in temperature 2-4 is caused by the fact that in the thermal unit of modification 2 is distant the insulating plug. A difference in temperature 3-4 is the result of replacing the brass edge for the Manganin.

Data of Table 2 (difference (4-1)) show that within the daytime periods coating the plant framework with enamel VL-548 decreases the temperature of thermal resistor from 0.1°C in the first five-kilometer layer to 1.9°C by the height/altitude of 30-35 km. At night readings/indications of thermal units of 1st and 4th modifications are virtually identical.

Further, laboratory/investigations (Table 1) showed the perceptible effect from the liquidation of the insulating plug of the thermal unit. However, as we see from the data of Table 2, under the actual conditions of the essential differences between readings/indications of these modifications of thermal units it is

DOC = 82068203

PAGE

44

not observed. At the same time for the purpose of savings and simplification in the thermal unit this part can be removed without the damage for the structural strength.

The replacement of the brass framework to the Manganin does not introduce substantial changes into the results of sounding. Readings/indications of these thermal units are close to each other to the height/altitude of 30-35 km.

Page 22. Table 2. Systematic (Δ) and root-mean-square (σ) differences in readings/indications of temperature of the thermal units of different constructions/designs.

| (3) № модификация термоузла | Δ , σ | (1) Слой, км | | | | | | | | | | | | | | (2) Выше 35 км |
|-----------------------------------|---------------------|--------------|-------------|-------------|-------------|-------------|-------------|-------------|-------------|-------------|-------------|-------------|-------------|-------------|-------------|----------------------|
| | | 0-5 | | 5-10 | | 10-15 | | 15-20 | | 20-25 | | 25-30 | | 30-35 | | |
| | | (4) день | (5) ночь | (4) день | (5) ночь | (4) день | (5) ночь | (4) день | (5) ночь | (4) день | (5) ночь | (4) день | (5) ночь | (4) день | (5) ночь | |
| 2-1 | Δ | -0,2 | -0,4 | -0,5 | -0,4 | -0,3 | -0,3 | -0,9 | -0,5 | -0,8 | -0,3 | -1,1 | -0,1 | -1,6 | 0,0 | -1,7 |
| | σ | 0,52 | 0,39 | 0,54 | 0,27 | 0,52 | 0,20 | 0,65 | 0,61 | 0,66 | 0,23 | 0,62 | 0,26 | 0,56 | 0,26 | 0,55 |
| 3-1 | Δ | -0,3 | 0,0 | -0,4 | -0,1 | -0,4 | -0,1 | -0,6 | -0,5 | -0,6 | -0,1 | -1,1 | -0,1 | -1,7 | -0,1 | -2,1 |
| | σ | 0,42 | 0,45 | 0,45 | 0,30 | 0,45 | 0,34 | 0,61 | 0,14 | 0,77 | 0,39 | 0,66 | 0,42 | 0,89 | 0,33 | 0,78 |
| 4-1 | Δ | -0,1 | -0,1 | -0,2 | -0,4 | -0,3 | -0,1 | -0,7 | -0,6 | -0,7 | -0,3 | -1,3 | 0,0 | -1,9 | -0,1 | -1,9 |
| | σ | 0,42 | 0,34 | 0,61 | 0,27 | 0,54 | 0,42 | 0,49 | 0,22 | 0,40 | 0,16 | 0,75 | 0,53 | 0,57 | 0,35 | 1,66 |
| 2-3 | Δ | 0,1 | -0,4 | 0,0 | -0,3 | 0,1 | -0,2 | -0,3 | 0,0 | -0,2 | -0,2 | -0,1 | 0,0 | 0,1 | 0,1 | 0,5 |
| | σ | 0,43 | 0,54 | 0,59 | 0,22 | 0,39 | 0,21 | 0,61 | 0,19 | 0,70 | 0,23 | 0,65 | 0,26 | 0,93 | 0,24 | 0,99 |
| 2-4 | Δ | -0,1 | -0,3 | -0,2 | -0,2 | -0,1 | -0,1 | -0,2 | -0,1 | -0,0 | 0,0 | 0,2 | 0,0 | 0,2 | 0,1 | 0,1 |
| | σ | 0,59 | 0,51 | 0,45 | 0,28 | 0,66 | 0,34 | 0,8 | 0,28 | 0,67 | 0,23 | 0,48 | 0,33 | 0,51 | 0,43 | 0,46 |
| 3-4 | Δ | -0,2 | 0,0 | -0,1 | 0,1 | -0,1 | 0,0 | 0,2 | 0,0 | 0,2 | 0,1 | 0,3 | 0,0 | 0,1 | 0,0 | -0,1 |
| | σ | 0,41 | 0,21 | 0,55 | 0,34 | 0,67 | 0,29 | 0,61 | 0,20 | 0,78 | 0,33 | 0,97 | 0,16 | 0,90 | 0,33 | 0,95 |

Key: (1). Layer, km. (2). It is above 35 km. (3). No. of modifications of thermo-knot. (4). day. (5). night.

Page 23.

Above 35 km in the daytime the Manganin framework proves to be more coldly on 0.5°C. However, a number of observations is above 35 km -

it is very small.

It must be noted that the nonconformity between the results of laboratory and full-scale experiments is explained, first of all, by the inadequacy of the procedure of laboratory tests.

It is of interest to examine not only systematic, but also random component of the errors of each tested thermal unit. Values σ , given in Table 2 for each pair, make it possible to determine by the method of triple control/checking [3] individual spread in readings/indications of temperature to each of the thermal units in question.

Values σ_i for each thermal unit in °C are given in Table 3.

As can be seen from data of Table 3, value of the random errors of all constructions/designs of thermal units examined are close to each other. Thus a change of constructing/designing the thermal unit of radiosonde RKZ-2 in versions examined above does not lead to an increase in the random measuring errors.

Thus, as the anti-radiation coating of the thermal unit of radiosondes of the type RKZ instead of nitroenamel NTs-25 and silver it is necessary to utilize an enamel of the type VL-548, which leads

to a decrease in the radiation error in the radiosonde to the value of order 30o/o in entire altitude range without an increase in the random errors.

Received 7 April 1970.

REFERENCES

1. Зайчиков П. Ф., Фридрих М. Б. Влияние арматуры термоузла на тепловые ошибки терморезистора радиозонда РКЗ. Труды ЦАО, вып. 82, 1969, 92—96.
2. Шляхов В. П. и др. К выбору антирадиационных покрытий термоматрицков. Метеорология и гидрология, № 3, 1968, 93—101.
3. Зайчиков П. Ф. Метод тройного контроля и его применение для исследования точности радиозондов. Труды ЦАО, вып. 16, 1956.

Table 3.

| (1) Время выпуска радиозондов | σ_1 | σ_2 | σ_3 | σ_4 |
|----------------------------------|------------|------------|------------|------------|
| (2) День | 0.36 | 0.41 | 0.50 | 0.45 |
| (3) Ночь | 0.25 | 0.28 | 0.21 | 0.24 |

Key: (1). Time of radiosonde ballooning. (2). Day. (3). Night.

Page 139.

Short reports.

AEROLOGICAL RADIOSONDE OF THE TYPE RKZ-5--2.

N. N. Grushin, A. F. Kuzenkov, N. A. Kuz'micheva.

Technical features of the new aerological radiosonde RKZ-5--2 type are briefly described.

One of the methods of increasing the interference shielding of the telemetry of the system of radiosounding RKZ - "Meteor" is an increase of the duration of the so-called meteorological break in the radiation/emission of radiosonde during the appropriate contraction of the passband of the receiver of radar. During the construction of meteorological radar "Meteorit-2" the passband Δf of the receiver of aerological information was led by 5 kHz. With this band is provided the confident reception/procedure of impulses/momenta/pulses (meteorological breaks) by duration $\tau > 1/\Delta f$. Gain in the potential of receiver during the contraction of passband Δf , as are shown experiments, is proportional to the relation of the width of the meteorological channel before and after contraction.

For the joint operation with radar "Meteorit-2" is developed

radiosonde RKZ-5-2. Its difference from that operated at present on the aerological network/grid of radiosonde RKZ-2 consists of the following. For the purpose of an increase in the duration of the meteorological breaks the value of reference frequency, developed by the signal generator of radiosonde, is selected as being equal to 1000 Hz (in RKZ-2 - 2000 Hz). Are respectively lowered the frequencies of temperature and humidity. The durations of the meteorological breaks range from 250 μ s (at the reference frequency) to half of the repetition period of these pauses. To greater meteorological frequencies correspond the smaller durations of the meteorological breaks. The schematic diagram of radiosonde RKZ-5-2 (Fig. 1) did not undergo unessential changes. Is reduced the measuring current, flowing through the thermal resistor. Thermo-knot is utilized the same as in radiosonde RKZ-2. As switching system of signal generator instead of the pressure switch is used the electromechanical commutator, which consists of the micro-electric motor, the retarding reducer and the contact board with the slide contact. The feed of micro-electric motor is realized from the 6-voltage section of the water-filled battery 200PMKhM-2ch.

Page 140.

The duration of transmission of one of the meteorological elements or the reference frequency in radiosonde RKZ-5-2 is determined

sufficiently stably for the elongation/extent of entire flight of radiosonde only by the construction/design of the commutator (but not less than 15 s). The tests of radiosondes RKZ-5-2 on the experimental aerological base at Dolgoprudnyy during February - March of 1970 showed good performing characteristics of this radiosonde during the operational sounding of atmosphere with the aid of the radar "Meteorit-2".

Received 2 June 1970.

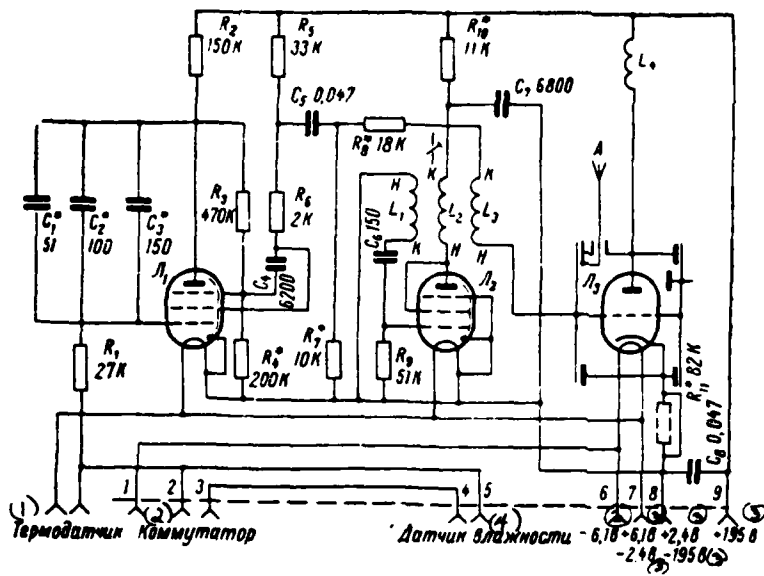

Fig. 1. Schematic diagram of a radiosonde of the type RKZ-5-2.

Key: (1). Temperature-sensitive element. (2). Commutator. (3). V. (4) Humidity sensor.