

AD-A117 720

AERONAUTICAL RESEARCH LABS MELBOURNE (AUSTRALIA)  
A SPECTRUM ANALYSER FOR ACOUSTIC EMISSION.(U)  
JUN 82 I G SCOTT  
ARL-MAT-TM-382

F/G 14/2

UNCLASSIFIED

NL



END  
DATE  
FORMED  
8-82  
DTIC

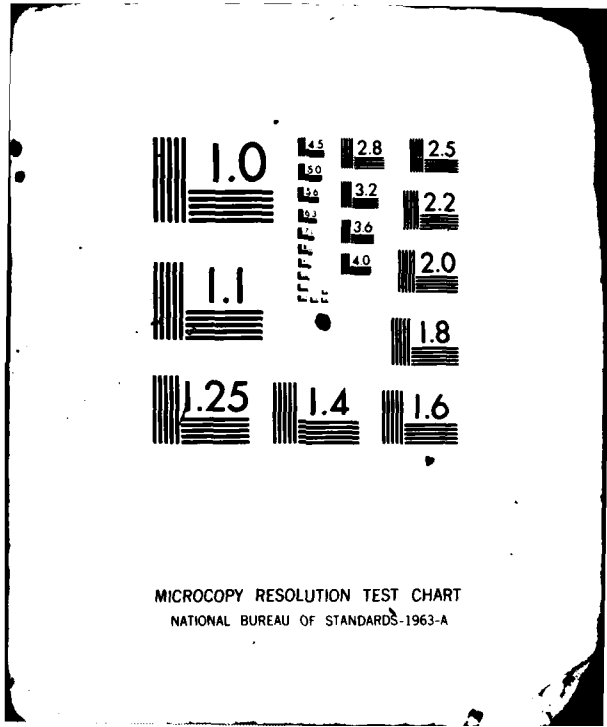

MICROCOPY RESOLUTION TEST CHART  
NATIONAL BUREAU OF STANDARDS-1963-A

UNCLASSIFIED

12

ARL-NAT-TECH-MEMO-382

AR-002-887



DEPARTMENT OF DEFENCE SUPPORT  
DEFENCE SCIENCE AND TECHNOLOGY ORGANISATION  
AERONAUTICAL RESEARCH LABORATORIES  
MELBOURNE, VICTORIA

AD A 11 7 20

Materials Technical Memorandum 382

A SPECTRUM ANALYSER FOR ACOUSTIC EMISSION

I.G. SCOTT

Approved for Public Release

DTIC FILE COPY

DTIC  
ELECTE  
AUG 3 1982  
S D  
D

(C) COMMONWEALTH OF AUSTRALIA 1982

COPY No

JUNE, 1982

UNCLASSIFIED 82 08 03 053

DEPARTMENT OF DEFENCE SUPPORT  
DEFENCE SCIENCE AND TECHNOLOGY ORGANISATION  
AERONAUTICAL RESEARCH LABORATORIES

Materials Technical Memorandum 382

A SPECTRUM ANALYSER FOR ACOUSTIC EMISSION

by

I.G. SCOTT

Summary

A parallel filter, spectrum analyser is described which can be made using simple circuits and cheap, readily available components.



© COMMONWEALTH OF AUSTRALIA

---

POSTAL ADDRESS: Chief Superintendent, Aeronautical Research Laboratories,  
P.O. Box 4331, Melbourne, Victoria, 3001, Australia.

CONTENTS

PAGE NO.

1. INTRODUCTION	1
2. SYSTEM SPECIFICATION	1
3. SYSTEM DETAIL	2
4. DISCUSSION OF SYSTEM FEATURES	3
5. FUTURE DEVELOPMENTS	4
6. CONCLUSIONS	5

REFERENCES

TABLE

DISTRIBUTION

DOCUMENT CONTROL DATA

Accession For	
NTIS GRA&I	<input checked="" type="checkbox"/>
DTIC TAB	<input type="checkbox"/>
Unannounced	<input type="checkbox"/>
Justification	
By _____	
Distribution/	
Availability Codes	
Dist	Avail and/or Special
A	



## 1. INTRODUCTION

Frequency analysis of acoustic emission (AE) involves the capture and analysis, or real-time analysis, of an impulsive or non-repetitive signal. The present ARL procedure involves the use of a transient recorder and conventional heterodyne spectrum analyser, and no more than one event per five seconds can be handled. Even with the adoption of a strict sampling procedure, much information is lost, particularly during the important periods of intensive AE activity.

Upton (1977) discussed the use of the heterodyne analyser, of parallel analogue or digital filters, and of the FFT algorithm. Commercial equipment based on these principles is available but expensive. Clark and Mathieson (1977), and Graham (1979), used matched sets of band-pass filters whose centre frequencies were related by a fixed ratio. This method of spectral analysis is fast, provides an output suitable for handling by a computer and, by restricting the number of bands, suppresses much unwanted detail in the spectrum. It was chosen for laboratory development and was constructed from available cheap components.

## 2. SYSTEM SPECIFICATION

The response time of the parallel filter system is determined by the filter with the lowest centre frequency. An approximation to filter response time,  $T$ , is given by

$$T = \frac{1}{B} = \frac{Q}{f_0}$$

where  $B$  is the bandwidth and  $f_0$  is the centre frequency; for  $f_0 = 0.1$  MHz and  $Q = 5$ ,  $T = 50\mu\text{s}$ . Allowing (say)  $25\mu\text{s}$  for the operation of logic devices results in a minimum recording period of  $75\mu\text{s}$ . For an aluminium specimen (longitudinal wave velocity =  $6.32$  mm/ $\mu\text{s}$ ) of width  $63.2$  mm, the first reflected wave can arrive  $20\mu\text{s}$  after the direct wave. However, for many laboratory-size specimens, ring-downs lasting about  $1$  ms have been observed. Hence,  $1$  ms was chosen as the recording period. (NOTE:- it is commonly observed that spectra are dominated by specimen characteristics).

It was planned to cover the frequency range of  $0.1$  MHz to  $1$  MHz. Assuming that the filter cross-over points occur at  $-10$  dB, then, for  $Q = 5$ , the centre frequencies are determined (see below).

The above preliminary considerations form the basis for the system specification, viz.

- (i) System operation shall be triggered when the leading edge of an AE event exceeds the variable (but preset) threshold level.
- (ii) The duration of the recording period shall be 1ms.
- (iii) Spectral data shall be read out to a plotter such that the total sweep time is 2s (but provision shall be made for reduction of this time at a later date).
- (iv) System logic shall provide for remote pen control along with shifting of the base line after the completion of each record.
- (v) Acceptance of additional AE signals during the sweep time is not permitted.
- (vi) The centre frequencies of the filters shall be : 0.100, 0.147, 0.215, 0.316, 0.464, 0.681 and 1.00 MHz.
- (vii) The peak value of output during the 1ms period, from each individual filter, shall be recorded.

### 3. SYSTEM DETAIL

Given a workable specification, system detailing becomes relatively straight forward and the functions of the system elements can be tabulated (Table 1). Some interesting features are :

- (i) Filter design: In many respects, the use of a passive filter is desirable but extensive experience with active filters led to a satisfactory design using the  $\mu$ A 715 operational amplifier. The circuit for the 0.464 MHz filter is shown in Figure 1, compensation appropriate to a gain of 10 being applied. Minor problems with the 1 MHz filter were overcome by using unequal capacitors, which causes slight asymmetry of the response curve.
- (ii) Plotter control: Three interconnected counter-multiplexer pairs (DM 7493/DM 7501) were used to provide a time-base, to select filter-inputs and to shift the base line of the display. Seven output levels resulted but, in order to provide zero reference, the 0.1 MHz filter was deleted.

The clock runs continuously; thus one can ensure that the counter is always started by an upward-going signal. The clock is connected to the counter via a synchronising circuit. A pulse, generated from the input

signal, and marginally longer than the clock pulse, is fed to an AND gate along with the clock pulse. The output drives an analogue switch, which connects clock and counter.

At the end of the sweep a CLEAR pulse is derived from one of the multiplexers. However, reliable operation was not obtained until a signal was applied to the RESET of the counter. A PAUSE between plotter sweeps is provided by controlling the length of the CLEAR pulse.

- (iii) Sample-and-hold circuits: The CLEAR pulse is used to sequentially discharge the condensers associated with the sample-and-hold circuits (LM 398) and ready them for acceptance of the next signal. The PEAK condenser is charged to a voltage proportional to the peak output from the filter band (the effect of accumulated small signals occurring between recording periods is disregarded). At the conclusion of the recording period, an ACQUIRE pulse is generated and the condenser voltage is held (or charge is stored) during the read-out or sweep period. If more than one event occurs during the recording period (which is unlikely), then the maximum value of the signal in the filter band will be recorded. The analyser logic is shown in Figure 2.

#### 4. DISCUSSION OF SYSTEM FEATURES

A continuous wave signal was input to the analyser and several single sweeps, each at a fixed frequency, were recorded. The resulting calibration is shown in Figure 3. Some unusual effects arise from the relationship between input and filter frequencies. However, for a given input, the output is unique. If improved frequency definition is desired, or if the amplitude of the cross-over point is decreased, then more filters, each having increased  $Q$ , will be needed to cover the same range. Some problems in filter design can be anticipated. Also, the output pattern will be changed and the present simplicity of presentation will be lost. Alternatively, it may be possible to develop the Collocott (1980) idea of a frequency discriminator having ultra-sharp response.

The system is intended for use over comparatively short periods of time - say about 30 mins. For most of the time only occasional AE events will occur, but at least one period of intense AE activity per test is anticipated. During the former period, small signals (noise or signals below trigger level) may collect on the PEAK condenser, but these are expected to leak away and cause minimal error. During the latter period, only a sampling of events

is possible (even when recording and sweep times are reduced - see next paragraph). Some analysis of multiple events will be made and some very large events will cause the system to trigger more than once. If a saturation event rate of  $1000 \text{ s}^{-1}$  is assumed, the probability of occurrence of an unidentified false signal is small. Clearly, a careful analysis of results is needed at high event rates.

Increasing the sampling rate for periods of intense AE activity may require two major changes. The first involves reduction of the recording time - although this is possible from a system stand-point, erroneous readings may result. Ring-down time is determined by the specimen-transducer-pre-amplifier combination and should be less than the recording time if multiple triggerings from the same event are to be avoided. For most purposes assumption of a recording time of 1ms is reasonable. The second major change requires the use of a read-out device (unspecified) which permits rapid acquisition of information. The clock pulse, CLEAR pulse and two sweep control pulses all need to be shortened (during system development this was done on several occasions to permit use of a CRO display).

#### 5. FUTURE DEVELOPMENTS

There are two aspects for future development - the first concerns different types of read-out device which would provide faster read-out while the second refers to different uses of the system and to some extent involves changes in specification.

Read-out time can be decreased to a limited extent by the use of rapid response plotters. Alternatively, signals can be recorded on analogue tape which is subsequently replayed at slower speed - presently the speed can be reduced by a factor of sixty. For very fast read-out, a digital approach is needed - this is heavy-handed in concept but may well turn out to be simple in application.

In view of the statistical nature of AE, it may be efficient to average spectra before read-out. This assumes that all spectra are similar, which has yet to be disproved. Sampling can be conducted in several ways: over a fixed period (say 10ms), over the whole of a test or for a chosen number of events. In all cases a marked relaxation of the present read-out requirement would result.

Finally, Graham (1979) has found that the use of a spectral parameter (e.g. ratio of amplitudes at two chosen frequencies) yields promising results. By using a logarithmic presentation of

output, ratios are obtained by subtraction. Provision has been made for the insertion of a log amplifier module in the present analyser.

6. CONCLUSIONS

The feasibility has been demonstrated of building a parallel filter, spectrum analyser using simple circuits and cheap, readily available components. Unwanted detail in spectra is suppressed.

output, ratios are obtained by subtraction. Provision has been made for the insertion of a log amplifier module in the present analyser.

6. CONCLUSIONS

The feasibility has been demonstrated of building a parallel filter, spectrum analyser using simple circuits and cheap, readily available components. Unwanted detail in spectra is suppressed.

#### REFERENCES

Clark, R.N. and Mathieson, T.A. (1977). Use of microprocessors in analysis of acoustic emission weld monitoring data. Proc. 11th Symp on NDE, San Antonio, Texas p.152-65.

Collocott, S.J. (1980). Frequency discriminator has ultra-sharp response. Electronics p.159 (Jan 3).

Graham, L.J. (1979). Multi-parameter analysis for acoustic emission source identification. Proc. 25th International Instn Symp Anaheim (May 7-10) p.53-8.

Upton, R. (1977). An objective comparison of analog and digital methods of real-time frequency analysis. Bruel and Kjaer Tech Rev. No. 1 p.18-26.

TABLE 1: FUNCTIONS OF SYSTEM ELEMENTS

ELEMENT	FUNCTION
MULTIPLER	<ul style="list-style-type: none"> <li>(1) Produce 8-step staircase voltage to serve as time base for plotter display (horizontal axis)</li> <li>(2) Select in turn, properly synchronised outputs from 7 sample-and-hold circuits (vertical axis)</li> <li>(3) Shift horizontal display vertically after each recorded signal</li> </ul>
PLOTTER CONTROL	<ul style="list-style-type: none"> <li>(1) Synchronise multiplexer operation with input signal</li> <li>(2) Initiate plotter pen operation</li> <li>(3) Operate PEN LIFT at completion of plot</li> </ul>
ANALYSER LOGIC	<ul style="list-style-type: none"> <li>(1) Compare input signal with threshold and produce lms logic pulse</li> <li>(2) Control sampling of filter output</li> <li>(3) Read and plot peak filter output; INHIBIT input during plotting</li> <li>(4) Discharge PEAK and HOLD capacitors at completion of plot</li> </ul>
ANALYSER	<ul style="list-style-type: none"> <li>(1) Sort signal frequencies using parallel filter bank</li> <li>(2) Sample and hold peak signal amplitude during lms period from each filter</li> </ul>

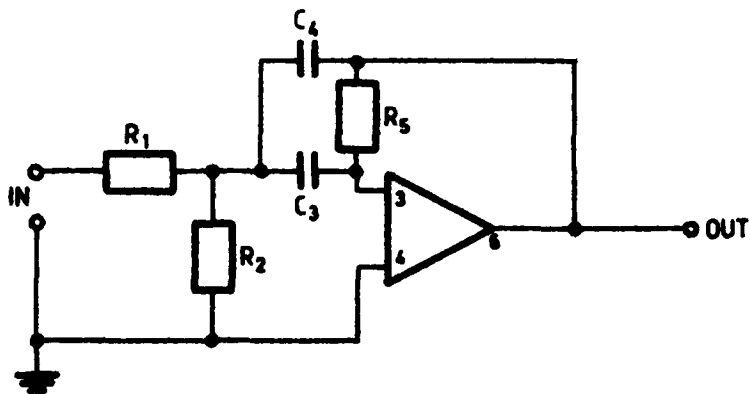

$\mu$ A 715 HC

Comp 1-9 100 pFd

7-10 220 pFd

+ Vcc 8 15V

- Vcc 5 15V

(each bypassed 0.1 mFd at pins)

R<sub>1</sub> 8.2 k ohm

R<sub>2</sub> 100 ohm

R<sub>5</sub> 22 k ohm

C<sub>3</sub> 220 pFd

C<sub>4</sub> 220 pFd

FIG. 1 CIRCUIT FOR NOMINAL 0.464 M Hz FILTER

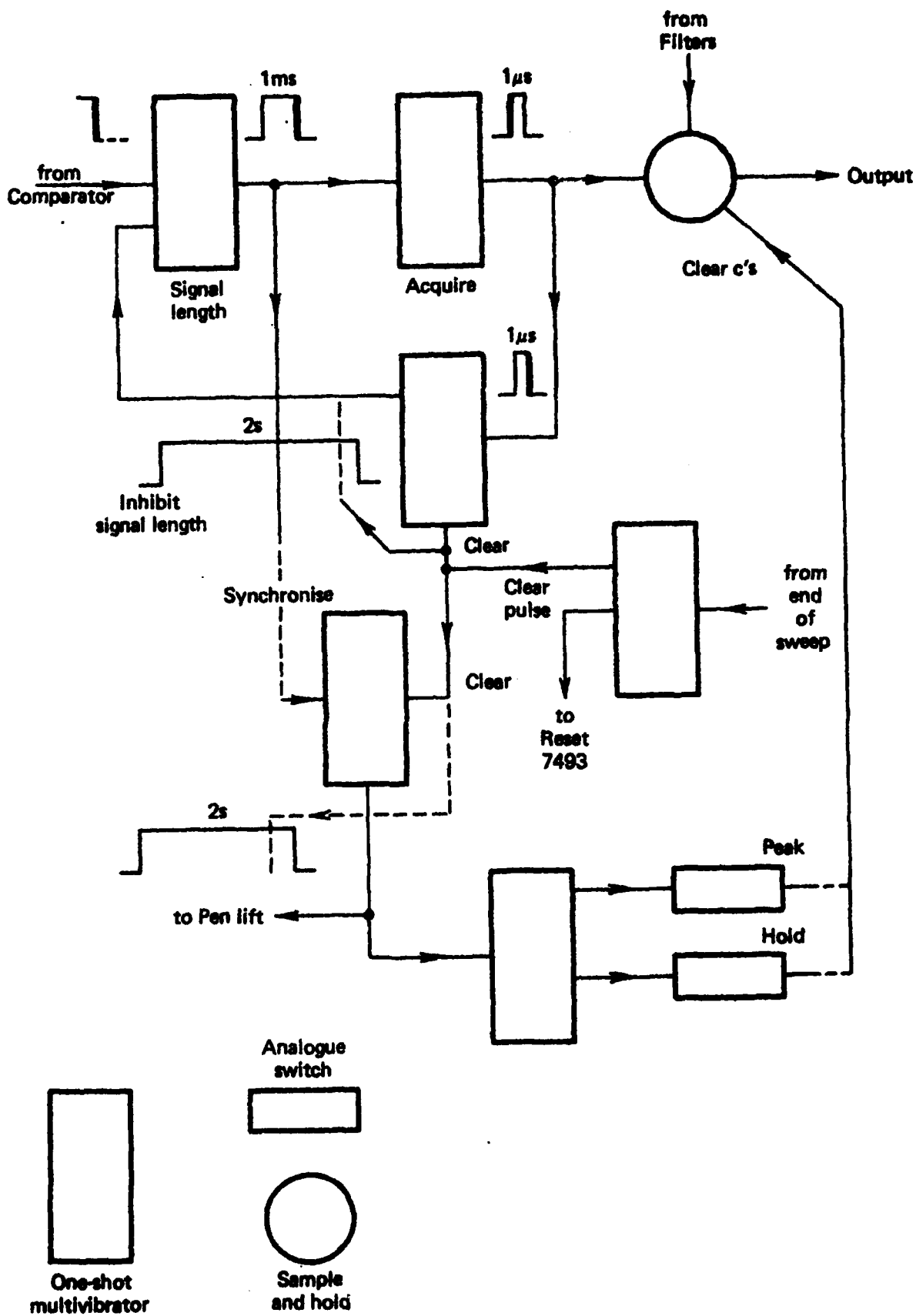

FIG. 2 ANALYSER LOGIC

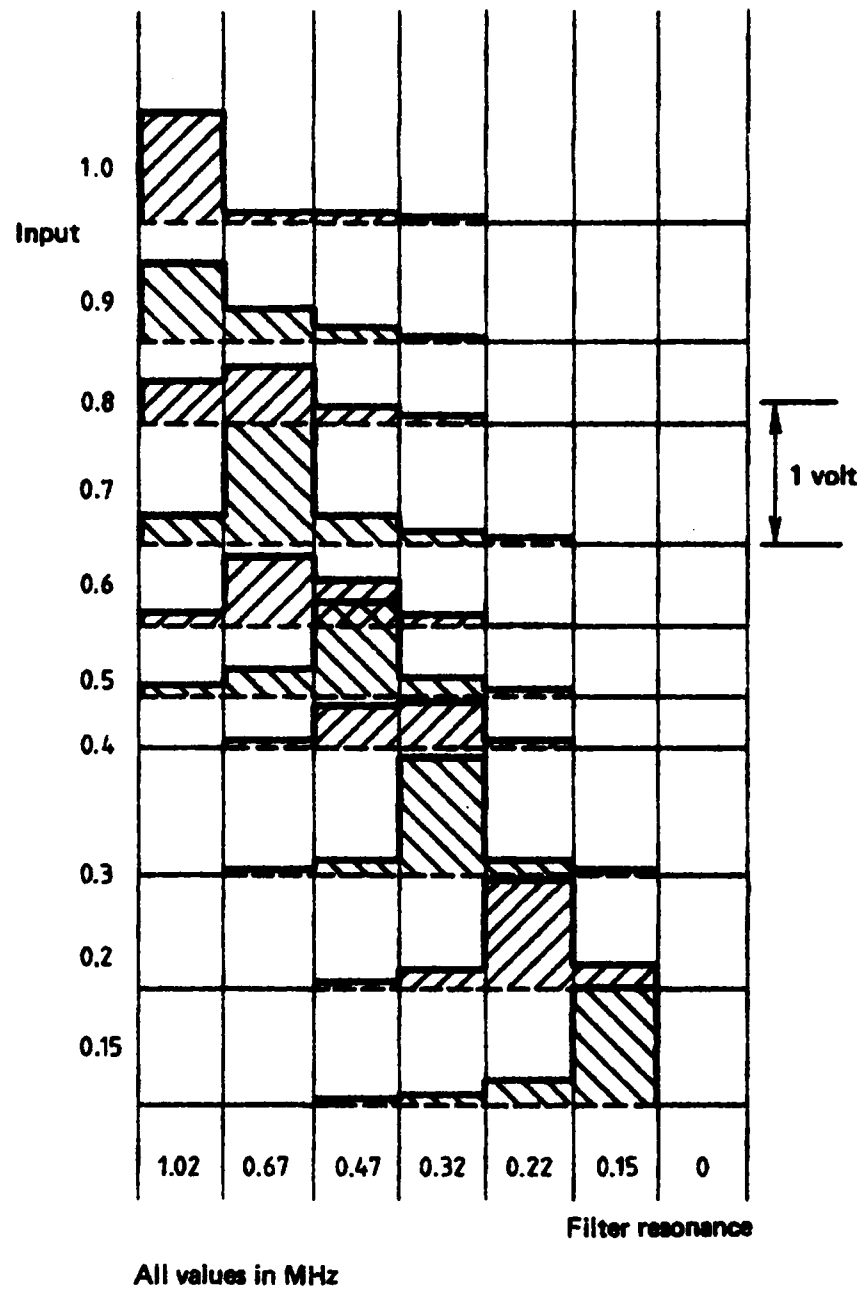

FIG. 3 CALIBRATION OF SPECTRUM ANALYSER

DISTRIBUTION

**AUSTRALIA**

Department of Defence and Department of Defence Support

Central Office

Chief Defence Scientist )  
Deputy Chief Defence Scientist )  
Superintendent, Science and Technology Programmes ) (1 copy)  
Controller, Projects and Analytical Studies )  
Defence Science Representative (U.K.) (Doc Data sheet only)  
Counsellor, Defence Science (U.S.A.) (Doc Data sheet only)  
Defence Central Library  
Document Exchange Centre, D.I.S.B. (17 copies)  
Joint Intelligence Organisation  
Librarian H Block, Victoria Barracks, Melbourne  
Director General - Army Development (NSO) (4 copies)

Aeronautical Research Laboratories

Chief Superintendent  
Library  
Superintendent - Materials  
Divisional File - Materials  
Author: I.G. Scott

Materials Research Laboratories

Chief Superintendent/Library

Defence Research Centre

Library

Central Studies Establishment

Information Centre

RAN Research Laboratory

Library

Navy Office

Navy Scientific Adviser

Army Office

Army Scientific Adviser

.../cont.

DISTRIBUTION (CONT.)

Air Force Office

Air Force Scientific Adviser  
Aircraft Research & Development Unit  
Scientific Flight Group  
Library

CANADA

Royal Military College, Kingston, Ontario (Attn. S.L. McBride)

UNITED STATES OF AMERICA

Naval Air Development Center, Warminster, Pa.  
(Attn. J. Carlyle)

SPARES (5 copies)

TOTAL (47 copies)

## DOCUMENT CONTROL DATA

1. a. AR No AR-002-887	1. b. Establishment No ARL-MAT-TECH-MEMO-382	2. Document Date June, 1982	3. Task No AIR 80/043
4. Title A SPECTRUM ANALYSER FOR ACOUSTIC EMMISSION		5. Security a. document UNCLASSIFIED	6. No Pages 5
		b. title      c. abstract U              U	7. No Refs 4
8. Author(s) I.G. SCOTT		9. Downgrading Instructions -	
10. Corporate Author and Address Aeronautical Research Laboratories.  G.P.O. Box 4331, MELBOURNE, VIC. 3001		11. Authority (as appropriate) a. Sponsor b. Security c. Downgrading d. Approval a) AIR FORCE OFFICE	
12. Secondary Distribution (of this document) Approved for Public Release.  Overseas enquirers outside stated limitations should be referred through ASDIS, Defence Information Services Branch, Department of Defence, Campbell Park, CANBERRA ACT 2601			
13. a. This document may be ANNOUNCED in catalogues and awareness services available to ... No limitations.			
13. b. Citation for other purposes (ie casual announcement) may be <del>restricted</del> / unrestricted <del>restricted</del> <del>restricted</del>			
14. Descriptors Electronic test equipment Spectrum analysis Stress waves		15. COSATI Group 0903 1402 2014	
16. Abstract  A parallel filter, spectrum analyser is described which can be made using simple circuits and cheap, readily available components.			

This page is to be used to record information which is required by the Establishment for its own use but which will not be added to the DISTIS data base unless specifically requested.

16. Abstract (Contd)		
17. Imprint Aeronautical Research Laboratories, Melbourne.		
18. Document Series and Number Materials Technical Memorandum 382	19. Cost Code 34 4780	20. Type of Report and Period Covered -
21. Computer Programs Used -		
22. Establishment File Ref(s) M1/8/433		

