

AD-A118 162

NAVAL OCEAN RESEARCH AND DEVELOPMENT ACTIVITY NSTL S--ETC F/G 4/2
OPERATION AND MAINTENANCE MANUAL FOR THE ATMOSPHERIC PROFILER S--ETC(U)
JUL 82 B E ECKSTEIN, C R HOLLAND

UNCLASSIFIED

NORDA-TN-164

NL

END
DATE
FILMED
10 82
DTIC

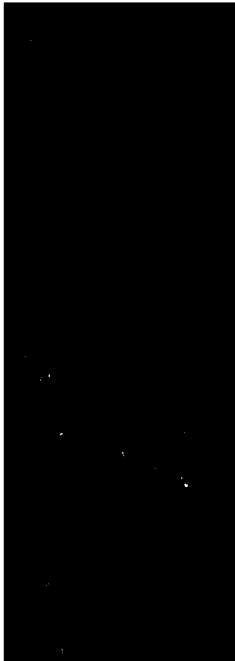

ABSTRACT

An atmospheric profiler system for measuring wind shear in the first 100 meters above the ocean surface was developed in FY 82 by the Instrumentation Branch (Code 352), Ocean Technology Division, Naval Ocean Research and Development Activity.

The delivered system consists of four multi-sensor, self-contained, telemetry units, which can be suspended from the tether of a buoyant balloon, and a four-frequency receiving subsystem. Each telemetry unit measures air temperature and wind speed; one of the units also measures barometric pressure. The sensor signals are composited in each of the units, and radio frequency is transmitted to a distant receiver. At the receiver site, the individual sensor signals are presented at the back of the receiver unit as analog signals ready for further processing and display.

A description is given of the system's performance and operating features as well as step-by-step instructions for checkout, calibration, and routine maintenance.

The atmospheric profiler system was developed for the Remote Sensing Branch (Code 335), Oceanography Division. After proposal acceptance, design/construction commenced in March 1981, with delivery scheduled for December 1981. Additional funding was allocated in October 1981 for total system calibration, and final delivery was made in March 1982.

Accession For	
NTIS GRA&I	<input checked="" type="checkbox"/>
DTIC TAB	<input type="checkbox"/>
Unannounced	<input type="checkbox"/>
Justification	
By _____	
Distribution/	
Availability Codes	
Dist	Avail and/or Special
A	



CONTENTS

1.0	INTRODUCTION	1
1.1	SYSTEM PURPOSE	1
1.2	SYSTEM FEATURES	1
2.0	SENSOR-TRANSMITTER UNIT	4
2.1	GENERAL	4
2.2	OPERATING PROCEDURES	4
2.3	BATTERY PACK	10
2.3.1	Battery Pack Construction	10
2.3.2	Battery Replacement	10
2.4	CALIBRATION	11
3.0	RECEIVER SYSTEM	12
3.1	GENERAL	12
3.2	OPERATING PROCEDURES	12
3.3	CALIBRATION	15
4.0	SYSTEM DEPLOYMENT AND OPERATION	16
4.1	RECEIVING SYSTEM ASSEMBLY	16
4.2	SENSOR-TRANSMITTER DEPLOYMENT	17

ILLUSTRATIONS

Figure 1.1	Sensor-Transmitter	2
Figure 1.2	Sensor-Transmitter Instrumentation	3
Figure 1.3	Receiver Site Block Diagram	5
Figure 2.1	Sensor-Transmitter Parts Assembly	6
Figure 2.2	Sensor-Transmitter Wiring Diagram	7
Figure 2.3	Battery Connections	8
Figure 2.4	Battery Pack Configuration	9
Figure 3.1	Receiver Chassis Panels	13
Figure 3.2	Receiving System Wiring Diagram	14

OPERATION AND MAINTENANCE MANUAL FOR THE ATMOSPHERIC PROFILER SYSTEM

1.0 INTRODUCTION

1.1 SYSTEM PURPOSE

The Atmospheric Profiler is a system designed to sample air temperature and wind velocity simultaneously at four different heights and to transmit this set of data continuously via an RF link to a receiving site where it is reproduced as analog output voltages.

1.2 SYSTEM FEATURES

The four Sensor-Transmitter (S-T) units are designed to be attached to a balloon tether at, for example, 10, 30, 60, and 100 meter heights as illustrated in Figure 1.1. These units are totally independent and self-contained. Each weighs about 4 pounds, is battery powered, and designed to transmit up to four channels of data continuously for 24 hours.

The S-T units consist of one large and three small units. The large unit, #1, is 22 inches high, 8-1/2 inches at its widest part, and weighs 3 pounds and 4 ounces.

The Atmospheric Profiler is instrumented as follows:

YSI Thermistor Model 44204
Range -2° to $+38^{\circ}$ C
Accuracy $\pm 0.15^{\circ}$ C

Setra System Barometer Model 270
Range 800-1100 mb
Accuracy ± 0.3 mb

R. M. Young Cup Anemometer Model 12101
Range 0-5 M/s
Threshold Sensitivity 0.35-0.45 M/S

Rosemont Barometer Model 1201F1A3A1BSC56
Range 800-1100 mb
Accuracy ± 0.3 mb

Figure 1.2 shows the internal instrument configuration. Notice that only the topmost unit contains a barometer. This unit, designated S-T #1, transmits air pressure data in addition to the temperature and wind speed. Air pressure data is used in the system to calculate the approximate height of the catenary suspended units. The fourth data channel carries a fixed voltage which can be used to monitor battery voltage. The basic carrier frequency for the units is 72 MHz. Each uses a half-wave dipole antenna and is designed to have an effective line-of-sight range of up to 5 miles. A pulse spacing modulation scheme is used to conserve battery power.

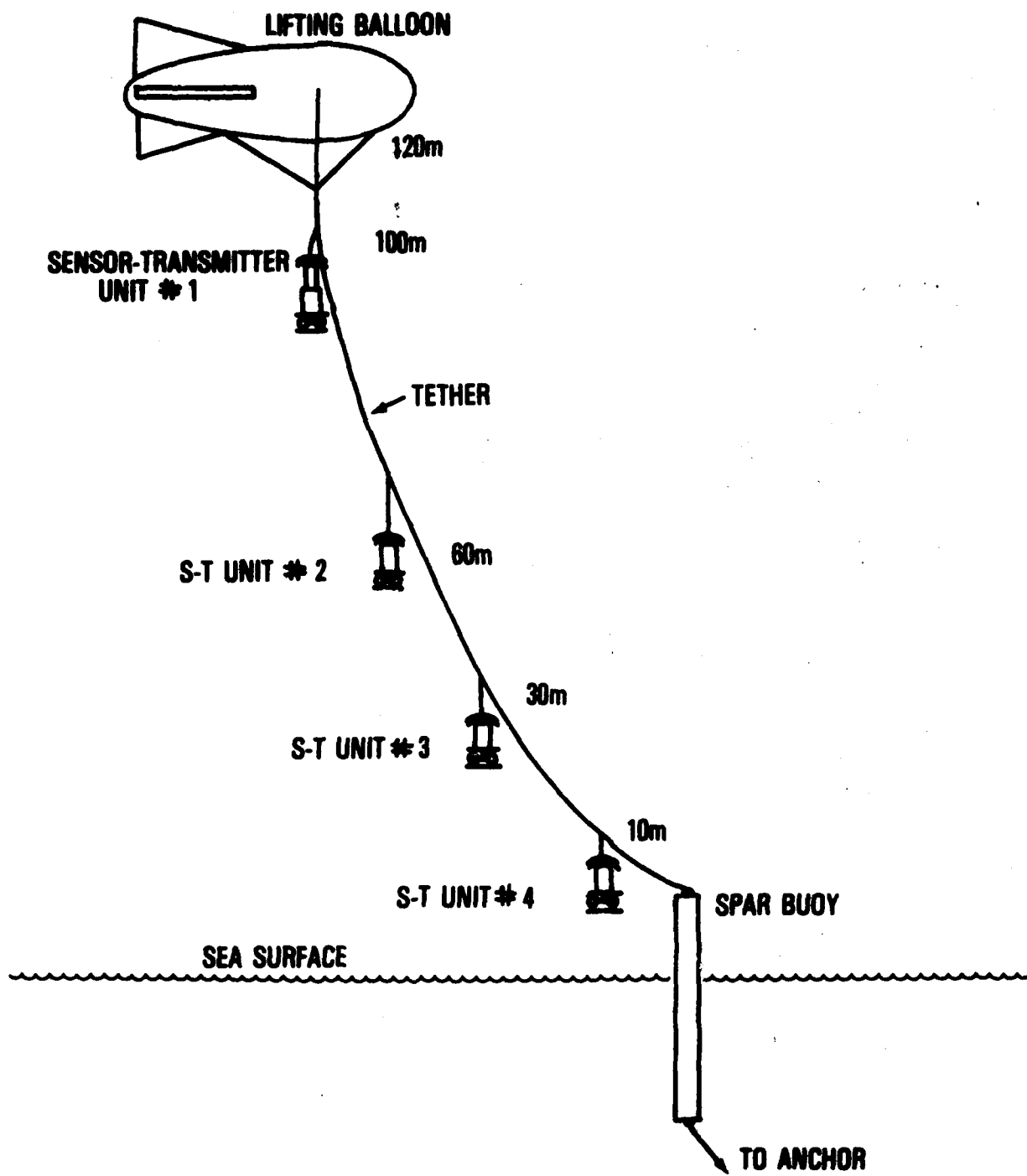

Figure 1.1 Sensor-Transmitter

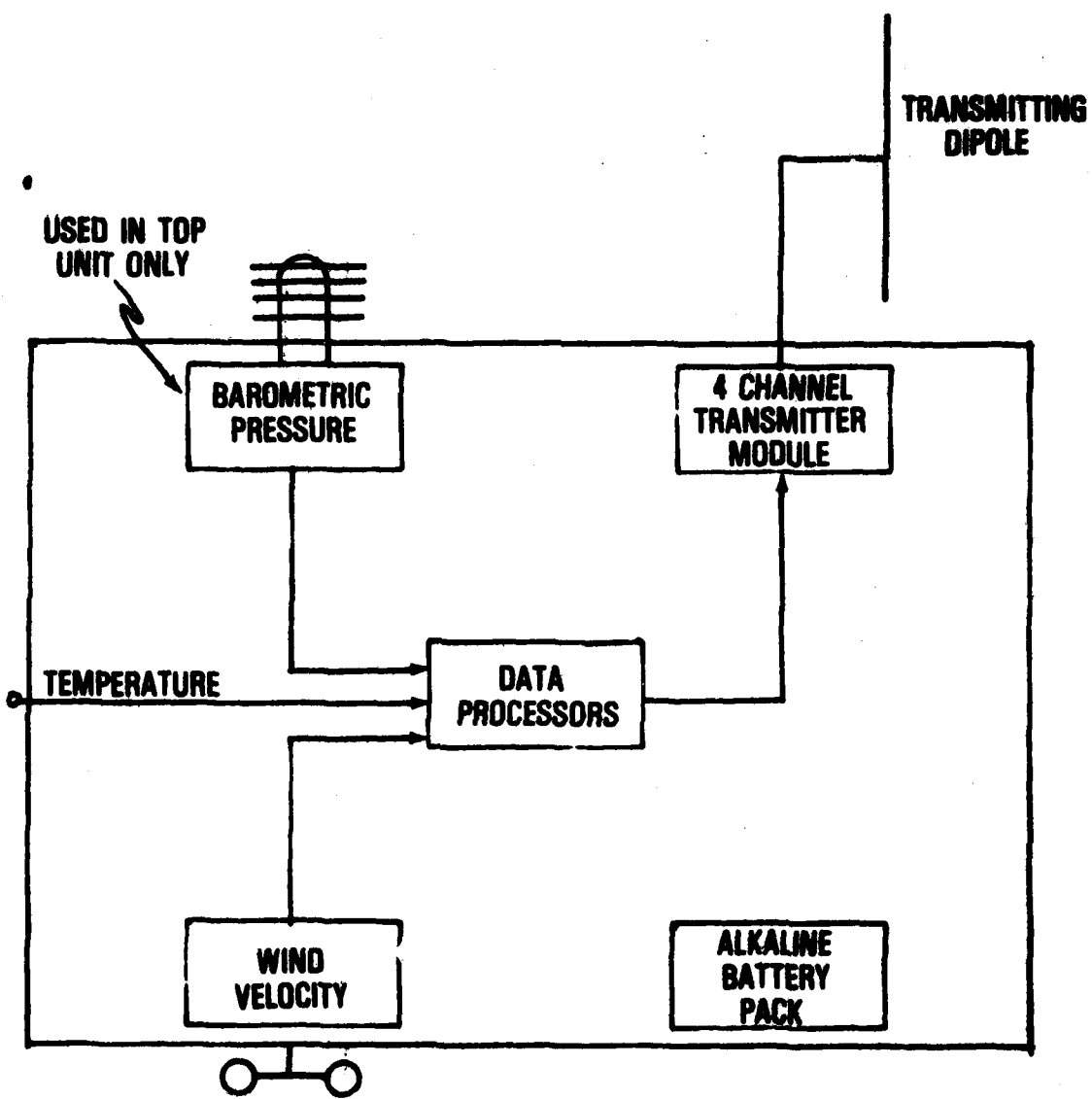

Figure 1.2 Sensor-Transmitter Instrumentation

Figure 1.3 shows a block diagram of the receiving system. The receiving antenna is a steerable Yagi designed for 72 MHz. All four of the signals from the S-T units are received simultaneously by the antenna where the four are separated by frequency selective receiver modules. These receiver modules and the processor sections convert the RF data signals to analog voltage outputs. The reference barometer provides sea level air pressure data to be compared to the air pressure data from the S-T #1 for the calculation of its height and the estimated height of the other three units.

Each of the three data inputs, temperature, wind velocity, and air pressure, along with a fixed reference voltage are sampled once every 25 milliseconds. Their sampled values are converted into pulse spacings and modulated onto the RF carrier. The value of the sample is represented by the spacing between pulses; the minimum being 1 millisecond and the maximum being 3 milliseconds.

2.0 SENSOR-TRANSMITTER UNIT

2.1 GENERAL

The functions of the S-T units are to gather atmospheric data and transmit it to a remote receiver. Each unit consists of sensors, electronics boards, a transmitting module and the required battery power. All four units have sensors for wind speed and temperature. Unit #1 has an air pressure sensor in addition to these sensors. Figure 2.1 shows the general physical configuration of the major components, as well as the additional components in unit #1. Listed below are the transmitter frequencies for each unit.

UNIT	FREQUENCY
1	72.080 MHz
2	72.240 MHz
3	72.160 MHz
4	72.320 MHz

Each S-T unit is powered by a circular battery pack located in the bottom of each unit. This pack consists of ten 1.5V, AA, alkaline batteries. In addition to this pack, unit #1 requires a 9V alkaline battery which powers the barometer. Battery wiring and locations are shown in Figures 2.1, 2.2, 2.3, and 2.4.

2.2 OPERATING PROCEDURES

To apply power to the S-T units, remove the smallest permanent magnets taped to the sides of the units near the top. This will close internal magnetic switches and apply power throughout the unit. Retain the magnets when they are removed, as they will be needed later to turn off power. To do this, simply retape the magnets on the locations marked on the outside of each unit. Be sure to align the red end of each magnet with the red end of the location marker. Failure to do this will not activate the internal magnetic switches and will allow power to continue to be applied and, thus, deplete the batteries.

NOTE: There are 3 switches on unit #1 and 2 switches on the other units.

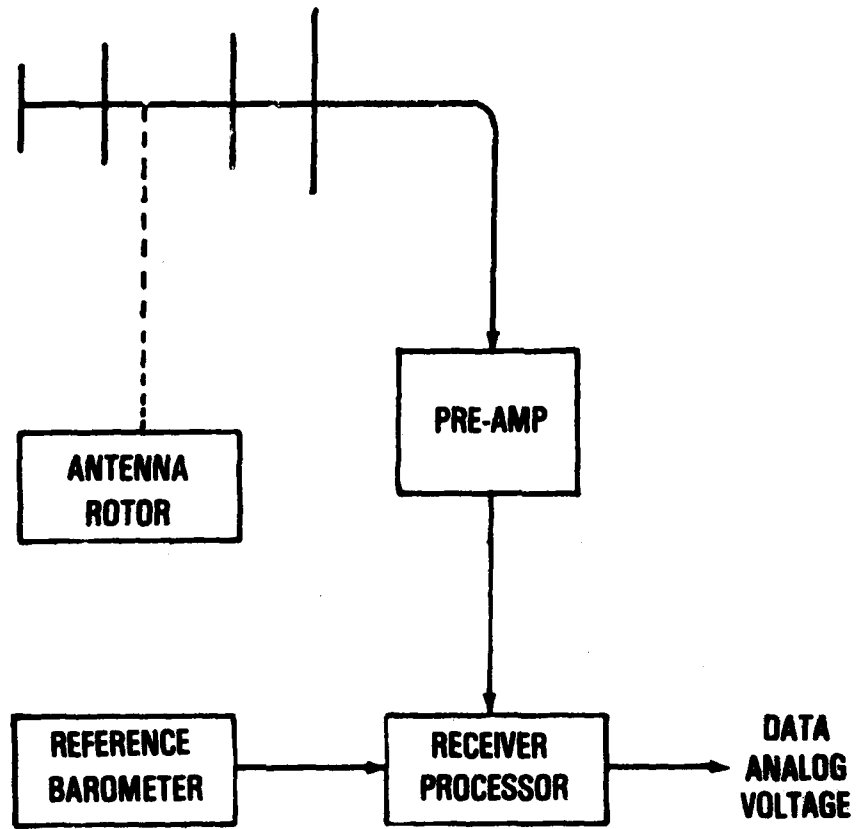

Figure 1.3 Receiver Site Block Diagram

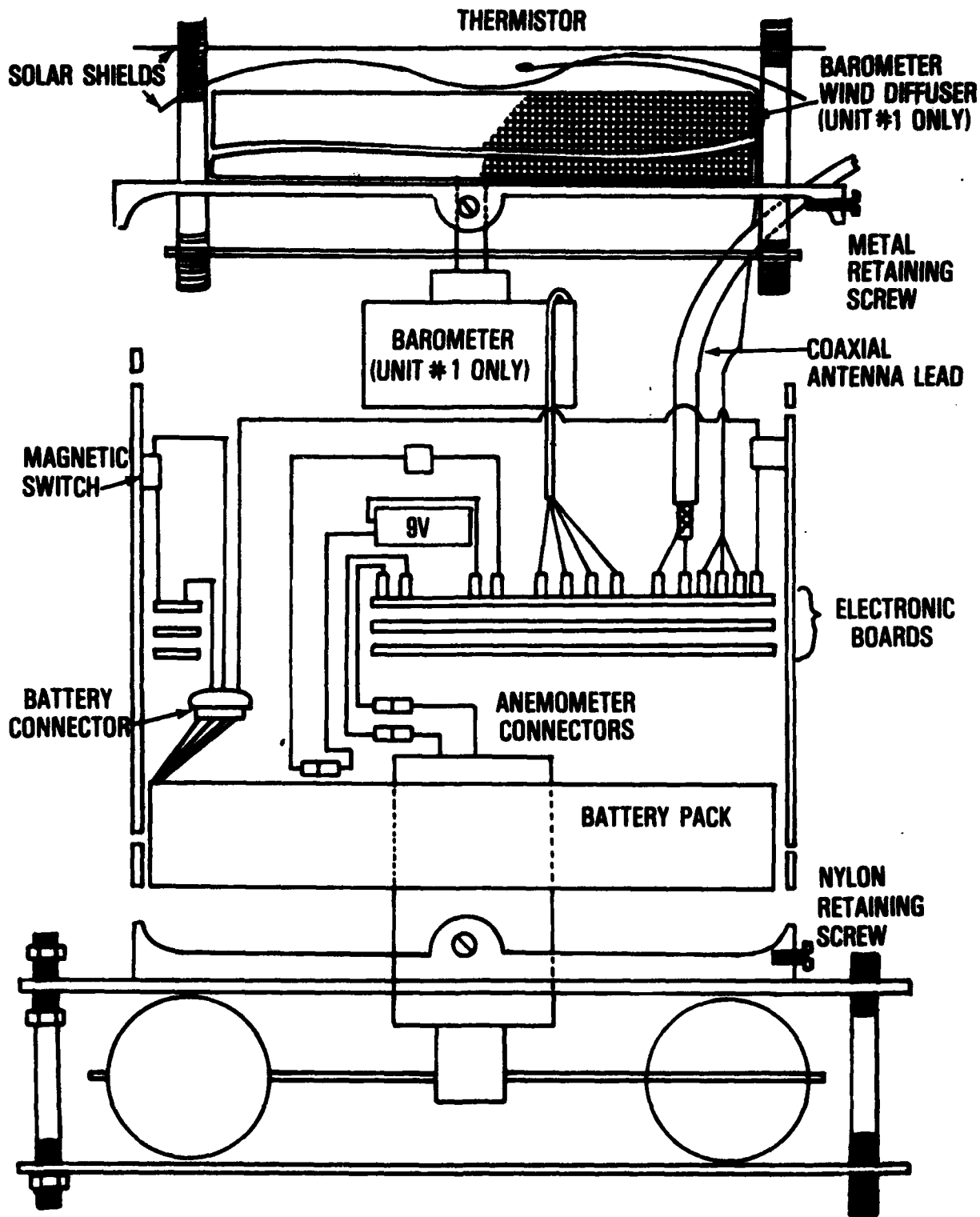

Figure 2.1 Sensor-Transmitter Parts Assembly

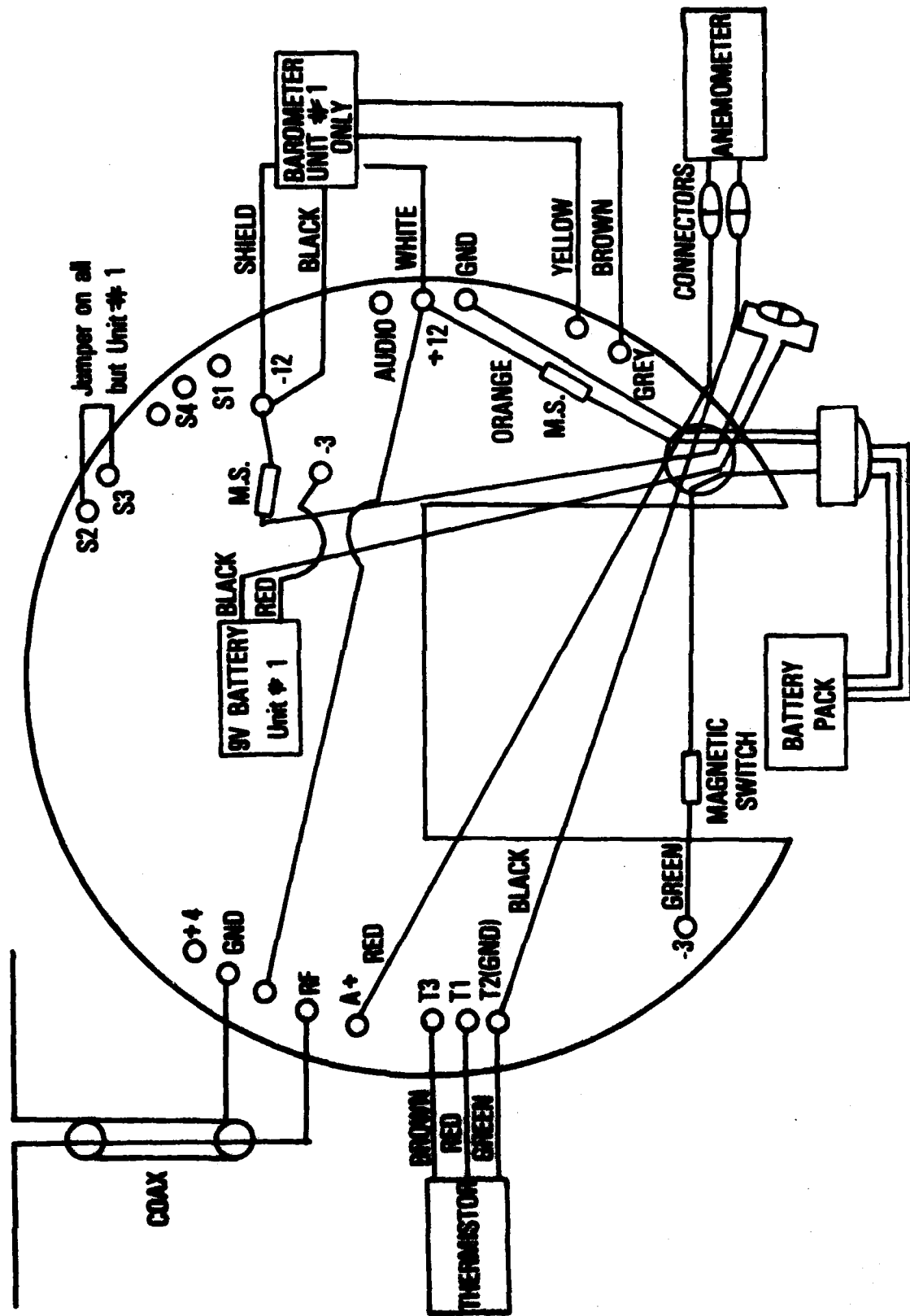

Figure 2.2 Sensor-Transmitter V.

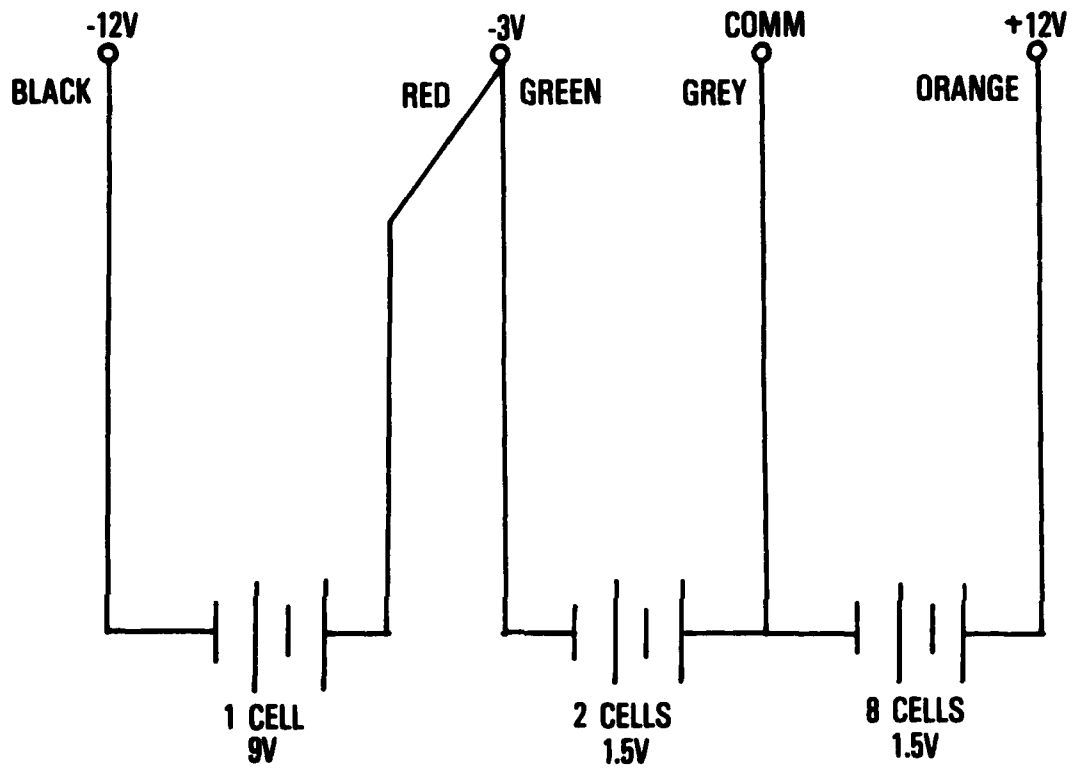

Figure 2.3 Battery Connections

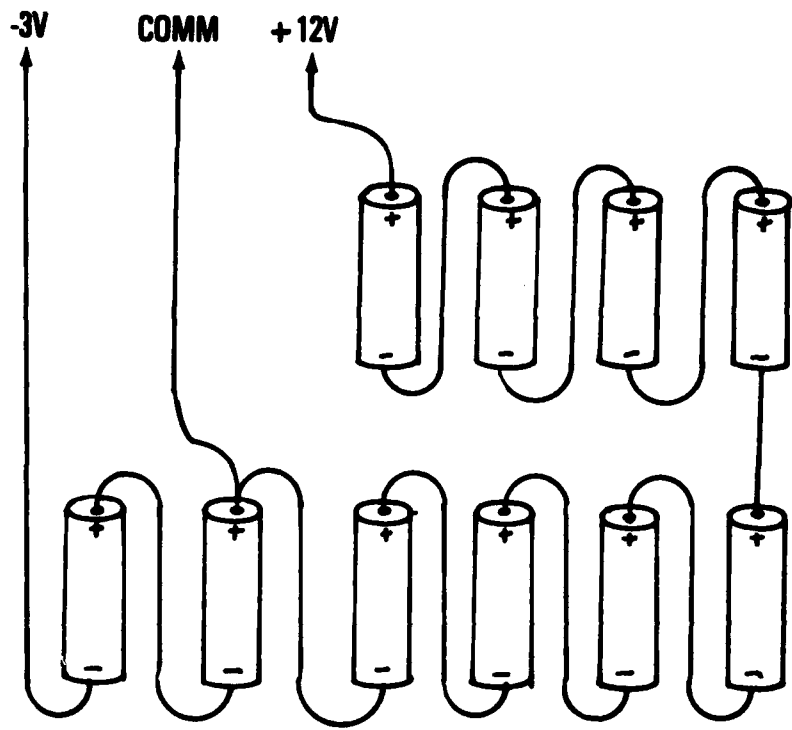

Figure 2.4 Battery Pack Configuration

Once power has been applied and the unit is operating, the best check of its operation is an output at the receiver end. Refer to the section on receiver operation for the test points to be checked.

2.3 BATTERY PACK

2.3.1 Battery Pack Construction

Replacement battery packs are not furnished and must be assembled by the user. Figures 2.3 and 2.4 show the electrical configuration of the 10 alkaline AA batteries that supply the -3V and +12V for each of the S-T units. These 1.5V batteries are wired in series and arranged in a doughnut-shaped package. Each battery pack should be no more than 4 inches in diameter, no more than 2 inches in height and must have a center hole of at least 1.25 inches. Styrofoam or similar material can be used to provide the necessary support and containment for the assembled batteries. The 9V battery is required only in S-T unit #1 and is located separate from the others. Figure 2.1 shows the location of the battery pack and the separate 9V battery.

2.3.2 Battery Replacement

Refer to Figures 2.1 and 2.2 to accomplish the following instructions more easily. CAUTION: Be sure that the magnets are taped securely in place to conserve battery life.

- (1) Remove and save the three nylon retaining screws from the base of cylinder.
- (2) Separate the cylinder and the anemometer, being careful of the red and black anemometer leads.
- (3) Disconnect the red and black leads and set the anemometer aside.
- (4) Pull the circular battery pack slowly from the end of the cylinder until the battery connector is clear.
- (5) Separate the battery connector plug and jack and set the exhausted battery pack aside.
- (6) For units #2, #3, and #4, skip to step 12.
- (7) Gently pull the circular electronics boards down and out of the end of the cylinder.
- (8) Locate the 9V battery atop the electronics boards.
- (9) Unsnap the connector from the depleted battery.
- (10) Snap a fresh battery on the connector.
- (11) Carefully reinsert the battery and electronics cards into the cylinder watching for pulled or pinched leads.

- (12) Insert the red and black leads and the shaft of the anemometer through the center of the circular battery pack.
- (13) Connect the battery pack plug and jack.
- (14) Reattach the red and black anemometer leads.
- (15) Gently insert the anemometer shaft and battery pack into the bottom of the cylinder being careful not to pinch or strain any leads.
- (16) Using the numbers on the outside of the unit, align the three holes in the cylinder wall with the three in the retaining ring. Insert and tighten the nylon retaining screws.

2.4 CALIBRATION

- (1) Follow steps 1 through 7 in the battery replacement procedure to gain access to the transmitter cards.
- (2) Reconnect the battery pack plug and jack.
- (3) Short together the red and black anemometer leads coming from the cards.
- (4) Apply power to the circuits by removing the magnets.
- (5) Apply +2.3109 volts to T1 (refer to Figure 2.3).
- (6) Adjust R26 for zero volts measured at S1.
- (7) Change the voltage applied to T1 to 3.2302 volts.
- (8) The voltage, now measured at S1, should be 5V.
- (9) Use an oscilloscope to view the waveform at Audio TP. There should be a spacing of 3 milliseconds between pulses 1 and 2.

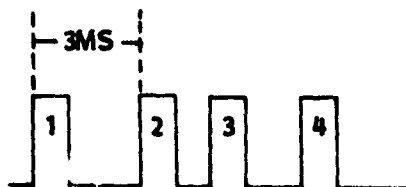

- (10) If the spacing is incorrect, adjust R3.
- (11) Connect the oscilloscope to the RF TP. There should be distinct pulses with no oscillations between pulses.



- (12) Adjust R18 to reduce any interpulse oscillations.



- (13) Reassemble the S-T unit following steps 11 through 16 in Section 2.3.2 above.

3.0 RECEIVER SYSTEM

The function of the receiving system is to accept RF signals from the four S-T units, convert, amplify, and present them as analog atmospheric data outputs. The receiving system consists of a directional antenna, an RF pre-amplifier, and the main receiver unit. The pre-amplifier and main receiver operate on 120 VAC 60 cycle.

3.2 OPERATING PROCEDURES

Refer to Figures 2.4 and 3.1 to aid in the following steps.

- (1) Connect the cables as indicated in Figure 3.2.
- (2) Connect the pre-amp and receiver power plugs to 120 VAC.
- (3) Set both ON/OFF switches to ON.
- (4) Connect an oscilloscope to the RX out jack on the rear of the unit (see Figure 8). Rotate the waveform test switch through positions 1, 2, 3, and 4. In each position the scope should display the waveform shown below.

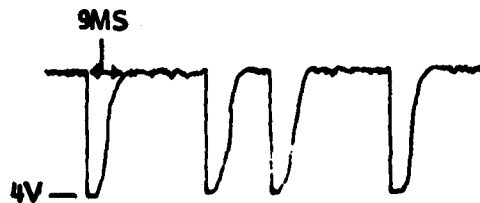

- (5) Move the scope cable to the M/V test jack and rotate the test switch. The scope should display the following waveform in all 4 positions.

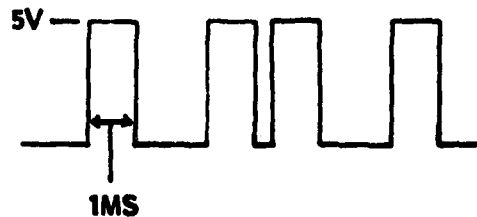

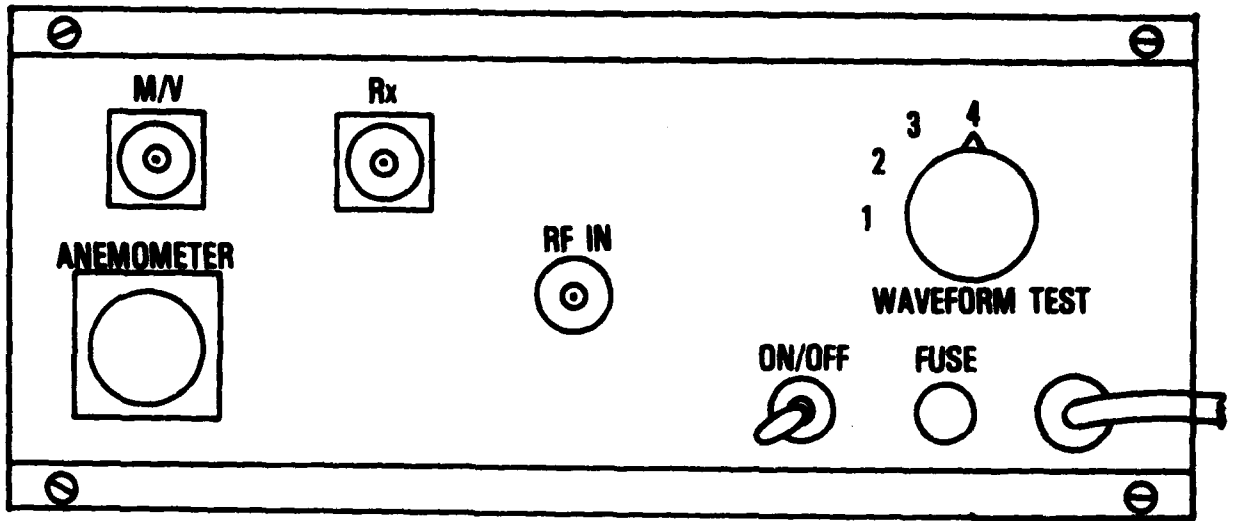

Rear Panel

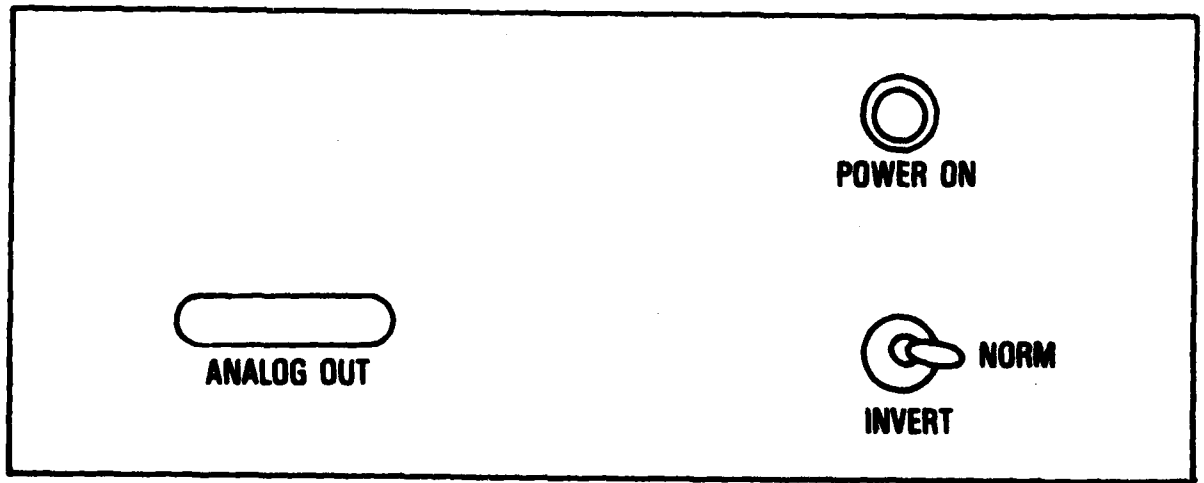

Front Panel

Figure 3.1 Receiver Chassis Panels

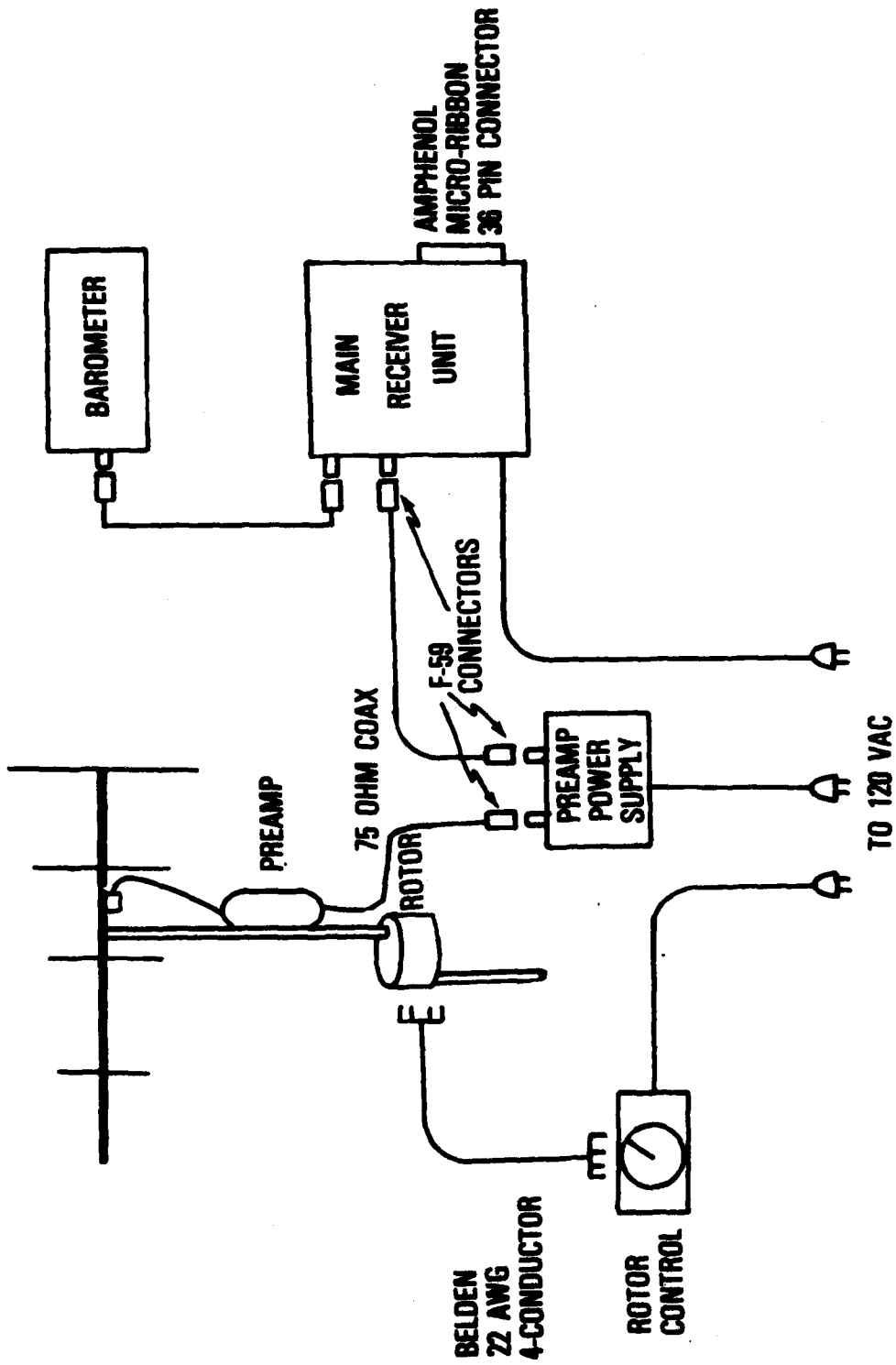

Figure 3.2 Receiving System Wiring Diagram

- (6) The analog outputs from each sensor are available at the front panel connector as follows:

	<u>UNIT #1</u>		<u>UNIT #2</u>		<u>UNIT #3</u>		<u>UNIT #4</u>	
	<u>SIG PIN</u>	<u>REF PIN</u>	<u>SIG PIN</u>	<u>REF PIN</u>	<u>SIG PIN</u>	<u>REF PIN</u>	<u>SIG PIN</u>	<u>REF PIN</u>
AIR TEMPERATURE	1	19	5	23	9	27	13	31
AIR PRESSURE	3	21						
(unit #1 only)								
WIND VELOCITY	4	22	8	26	12	30	16	34
REFERENCE AIR PRESSURE	17	35						

3.3 CALIBRATION

- (1) Remove top and bottom covers by removing 4 screws located in the rear of the receiver.
- (2) Remove receiver board #1 (board placement chart located inside top cover).
- (3) Insert calibration board in receiver board #1 slot.
- (4) Turn receiver on its side so chassis wiring is accessible.
- (5) Apply power to test meter and receiver and allow 30 minutes warm-up time.
- (6) Connect Tektronix 7704A oscilloscope or equivalent to calibration card PIN Z. Observe scope for a 4 mHz signal. Remove scope probe.
- (7) Attach negative clip from test meter to PIN A of the calibration card and the positive clip to PIN Y of DAC board #1, CHANNEL 1.
- (8) With NORMAL/INVERT switch in the INV position, observe test meter and adjust potentiometer R1(OFFSET) located on DAC board #1 for .0024 volts.
- (9) Holding the NORMAL/INVERT switch in the INV position, observe test meter and adjust R3(GAIN) of DAC board #1 for 9.9952 volts.
- (10) Release INV switch and observe meter for .0024 volts. If voltage has changed, repeat steps 8 and 9.
- (11) Remove negative clip and attach to PIN 19 of the connector located on the front of the receiver and positive clip to PIN 1.
- (12) Remove power.
- (13) Place DAC board #2, CHANNEL 1, on extender board and restore power.

- (14) Observe test meter and adjust R1 for .0024 volts.
- (15) Move test clip to PIN 2 and adjust R3 for .0024 volts.
- (16) Move test clip to PIN 3 and adjust R5 for .0024 volts.
- (17) Move test clip to PIN 4 and adjust R7 for .0024 volts.
- (18) Remove power, extender board, and test leads. Replace DAC board #2. Channel 1 is now calibrated.
- (19) Move to DAC board #1, CHANNEL 2. Repeat steps 5 through 18 (thirty minutes warm up time is not necessary, use PINS 5, 6, 7, and 8 in steps 14, 15, 16, and 17).
- (20) CHANNEL 2 is now calibrated.
- (21) Remove calibration board and receiver board #2. Replace receiver board #1 and insert calibration board in receiver board #2 slot.
- (22) Move the DAC board #1, CHANNEL 3. Repeat steps 5 through 18 (thirty minutes warm up time is not necessary, use PINS 9, 10, 11, and 12 in steps 14, 15, 16, and 17).
- (23) CHANNEL 3 is now calibrated.
- (24) Move to DAC board #1, CHANNEL 4. Repeat steps 5 through 18 (thirty minutes warm up time is not necessary).
- (25) CHANNEL 4 is now calibrated.
- (26) Remove power and probes from receiver. Remove calibration card and replace receiver board #2. Replace top and bottom covers.

4.0 SYSTEM DEPLOYMENT AND OPERATION

System deployment should begin with the interconnecting and powering of the receiver system. This is done to conserve the transmitter batteries and is logical since the receiver is used to verify the operation of the transmitters.

4.1 RECEIVING SYSTEM ASSEMBLY

- (1) Refer to Figure 3.2 for the proper interconnection of the receiving system.
- (2) When these connections have been secured, apply power to the rotor control.
- (3) Note that the POWER ON indicators light on the power supply and receiver.

- (4) Rotate the rotor control CW or CCW to check for power to the control as indicated by a lighted dial.
- (5) Check for antenna rotation as the control is moved CW or CCW.

4.2 SENSOR-TRANSMITTER DEPLOYMENT

- (1) Secure each unit to the tether.
- (2) Fasten the two white antenna wires so that they are vertically straight and perpendicular to each other.
- (3) Apply power to each unit by removing the magnets taped to the outside tip of the cylinders. Be sure to retain these magnets as they will be needed later to shut off power to the units.
- (4) The transmit and receive system are now fully powered.
- (5) Monitor the signal level from the RX jack at the rear of the receiver chassis and rotate the antenna to the position giving the strongest signal level.

UNCLASSIFIED

SECURITY CLASSIFICATION OF THIS PAGE (When Data Entered)

REPORT DOCUMENTATION PAGE		READ INSTRUCTIONS BEFORE COMPLETING FORM	
1. REPORT NUMBER NORDA Technical Note 164	2. GOVT ACCESSION NO. ADA118162	3. RECIPIENT'S CATALOG NUMBER	
4. TITLE (and Subtitle) OPERATION AND MAINTENANCE MANUAL FOR THE ATMOSPHERIC PROFILER SYSTEM		5. TYPE OF REPORT & PERIOD COVERED	
		6. PERFORMING ORG. REPORT NUMBER	
7. AUTHOR(s) B. E. Eckstein R. L. Williams C. R. Holland		8. CONTRACT OR GRANT NUMBER(s)	
9. PERFORMING ORGANIZATION NAME AND ADDRESS Naval Ocean Research and Development Activity NSTL Station, Mississippi 39529		10. PROGRAM ELEMENT, PROJECT, TASK AREA & WORK UNIT NUMBERS	
11. CONTROLLING OFFICE NAME AND ADDRESS Naval Ocean Research and Development Activity NSTL Station, Mississippi 39529		12. REPORT DATE July 1982	
		13. NUMBER OF PAGES 20	
14. MONITORING AGENCY NAME & ADDRESS (if different from Controlling Office)		15. SECURITY CLASS. (of this report) UNCLASSIFIED	
		15a. DECLASSIFICATION/DOWNGRADING SCHEDULE	
16. DISTRIBUTION STATEMENT (of this Report) Distribution Unlimited			
<table border="1"> <tr> <td>DISTRIBUTION STATEMENT A Approved for public release; Distribution Unlimited</td> </tr> </table>			DISTRIBUTION STATEMENT A Approved for public release; Distribution Unlimited
DISTRIBUTION STATEMENT A Approved for public release; Distribution Unlimited			
17. DISTRIBUTION STATEMENT (of the abstract entered in Block 20, if different from Report)			
18. SUPPLEMENTARY NOTES			
19. KEY WORDS (Continue on reverse side if necessary and identify by block number) Atmospheric Measurements Wind Profiles Air/Sea Interaction Measurements Balloon Launched Instrumentation			
20. ABSTRACT (Continue on reverse side if necessary and identify by block number) An atmospheric profiler system for measuring wind shear in the first 100 meters above the ocean surface was developed in FY 82 by the Instrumentation Branch (Code 352), Ocean Technology Division, Naval Ocean Research and Development Activity. The delivered system consists of four multi-sensor, self-contained, telemetry units, which can be suspended from the tether of a buoyant balloon.			

DD FORM 1 JAN 73 1473

EDITION OF 1 NOV 65 IS OBSOLETE
S/N 0100-LP-014-6601

UNCLASSIFIED

SECURITY CLASSIFICATION OF THIS PAGE (When Data Entered)

UNCLASSIFIED

SECURITY CLASSIFICATION OF THIS PAGE (When Data Entered)

and a four-frequency receiving subsystem. Each telemetry unit measures air temperature and wind speed; one of the units also measures barometric pressure. The sensor signals are composited in each of the units, and radio frequency is transmitted to a distant receiver. At the receiver site, the individual sensor signals are presented at the back of the receiver unit as analog signals ready for further processing and display.

A description is given of the system's performance and operating features as well as step-by-step instructions for checkout, calibration, and routine maintenance.

The atmospheric profiler system was developed for the Remote Sensing Branch (Code 335), Oceanography Division. After proposal acceptance, design/construction commenced in March 1981, with delivery scheduled for December 1981. Additional funding was allocated in October 1981 for total system calibration, and final delivery was made in March 1982.

UNCLASSIFIED

SECURITY CLASSIFICATION OF THIS PAGE (When Data Entered)