

AD-A118 514 NATIONAL AERONAUTICS AND SPACE ADMINISTRATION MOFFET--ETC F/G 1/3
A HELICOPTER HANDLING-QUALITIES STUDY OF THE EFFECTS OF ENGINE --ETC(U)
APR 82 L D CORLISS

UNCLASSIFIED

NL

| JF |
AD A
118514



END
DATE
FILMED
10-82
DTIC

AD A118514

①

A HELICOPTER HANDLING-QUALITIES STUDY OF THE EFFECTS OF
ENGINE RESPONSE CHARACTERISTICS, HEIGHT-CONTROL
DYNAMICS, AND EXCESS POWER ON NAP-OF-THE-EARTH OPERATIONS

Lloyd D. Corliss

U.S. Army Aeromechanics Laboratory

U.S. Army Research and Technology Laboratories (AVRADCOM)

Ames Research Center

Moffett Field, California

Presented at the AHS/NASA Specialists' Meeting
On Helicopter Handling Qualities
Palo Alto, California
April 1982

DTIC
ELECTE
AUG 25 1982
S H

DTIC FILE COPY

THIS PAPER IS DECLARED A WORK OF
THE U.S. GOVERNMENT AND
THEREFORE IS IN THE
PUBLIC DOMAIN



DISTRIBUTION STATEMENT A
Approved for public release;
Distribution Unlimited

82 08 23 131

A HELICOPTER HANDLING-QUALITIES STUDY OF THE EFFECTS OF
ENGINE RESPONSE CHARACTERISTICS, HEIGHT-CONTROL
DYNAMICS, AND EXCESS POWER ON NAP-OF-THE-EARTH OPERATIONS

Lloyd D. Corliss
U.S. Army Aeromechanics Laboratory
U.S. Army Research and Technology Laboratories (AVRADCOM)
Ames Research Center
Moffett Field, California

Abstract

A ground-based simulation study was conducted on a large-scale motion simulator to study the effects in the vertical axis of engine response characteristics on handling qualities for a nap-of-the-earth (NOE) operating environment. This study concentrated specifically on the helicopter configuration with an rpm-governed gas-turbine engine and expands previous work by focusing on aspects peculiar to rotary-wing and NOE operations. A wide range of engine response time, vehicle damping and sensitivity, and excess power levels was studied. The data are compared with the existing handling-qualities specifications, MIL-F-83300 and AGARD 577, and in general show a need for higher minimums when performing such NOE maneuvers as a dolphin and bob-up task.

↑
Nomenclature

K_n, K_u, K_e, K_1, K_2	} engine parameters (see Fig. 3)
$K_{PT}, K_p, K_R, K_T, K_q, \tau_e, \tau_p$	
N_1	engine gas generator speed, rpm
N_{11}	engine power turbine speed, rpm
NOE	nap-of-the-earth
PR	Cooper-Harper pilot rating
Q_{lim}	maximum torque, ft-lb
Q_{PT}	power turbine torque, ft-lb
Q_{ra}	torque required, ft-lb
T_{main}	thrust, main rotor, lb
T/W	thrust-to-weight ratio
Z_w	vertical damping, sec ⁻¹
\bar{Z}_w	equivalent vertical damping, sec ⁻¹
Z_{wa}	aerodynamic vertical damping, sec ⁻¹

Z_{wfus}	fuselage vertical damping, sec ⁻¹
$Z_{w_{inflow}}$	inflow vertical damping, sec ⁻¹
Z_{w_s}	stability augmentation vertical damping, sec ⁻¹
Z_{δ_c}	collective sensitivity g/in
ΔT	pure time delay, sec
ζ	damping ratio
τ_{eng}	equivalent first-order engine time-constant, (engine response time), sec ⁻¹
τ_T	thrust time constant, sec ⁻¹
Ω	rotor speed, rad/sec
ω_F	fuel flow, lb/hr
ω_n	second-order engine frequency, rad/sec

Introduction

The potential for improving helicopter flying qualities through the use of electronic fuel-control devices on helicopter gas turbine engines has led to a renewed interest in the study of coupling effects due to engine dynamics on the vehicle height and yaw responses. An understanding and quantification of these engine coupling effects is essential for the successful exploitation of the use of such controls. It is equally important to determine excess power requirements for specific tasks such as those pertaining to nap-of-the-earth (NOE) operations.

Early studies in the area of VTOL flying qualities¹⁻³ have provided a foundation for understanding fundamental effects such as the thrust response time-constant and excess power requirements. These studies involved ground-based simulation experiments that considered the near-hover tasks of station-keeping and rapid ascent and descent. Later studies^{4,5} expanded this work to consider the coupling effects of thrust response

Presented at the 38th Annual Forum of the American Helicopter Society, Moffett Field, California, April 1982.

DTIC
COPY
INSPECT

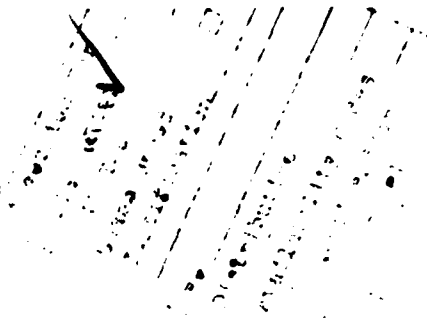

time with vertical velocity damping. These studies - together with the results of Ref. 6, which considers vertical damping only - form the basis for the vertical-axis handling-qualities specifications found in MIL-F-83300 and AGARD 577.

Reference 7 provides a good summary of the above studies and criteria; however, it is important to preface that those engine coupling studies considered a fixed wing VTOL (aircraft) for which the engine response time (τ_{eng}) and thrust response time (τ_T) were the same as depicted in Fig. 1. Such is not, in general, the situation for a rotary-wing aircraft with an rpm-governed rotor response, as shown in Fig. 2. This thrust response is influenced by a combination of the energy stored in the rotor, engine governor response, and the h damping resulting from rotor inflow. Thus, while the engine response of Fig. 2 may be simplified to a first-order time constant, the thrust response, as a rule, cannot be. Reference 8 does, in a limited sense, address this problem; however, what is needed is a review of the existing criteria and of the appropriateness of these requirements for rotary-wing vehicles. It is also essential that specific mission tasks be addressed (e.g., NOE operation) so that the criteria may be more directly applied to the design of modern military helicopters.

This paper describes a ground-simulation experiment that considered a wide range of engine response times and a wide range of vehicle vertical damping and collective control sensitivities for a helicopter model powered by an rpm-governed gas turbine engine. Several levels of available engine torque were also evaluated. The tasks performed were the NOE tasks of dolphin, quick-stop, and bob-up, and the study was performed on the Ames five-degree-of-freedom Vertical Motion Simulator (VMS) that used a model terrain-board visual system. An aural cueing system was used which provided the pilot with the sound of rotor overspeed and underspeed, blade slap, and transmission noise, and was based on an approach used in Ref. 9. The real-time simulation mathematical model consisted of a nine-degree-of-freedom helicopter model coupled to a simplified engine model, which included the first-order dynamics of the governor, gas generator, power turbine, and rotor/transmission inertias. The data obtained for this experiment are compared with previous studies and, where possible, with the existing criteria.

Description of Experiment

A requirement for this study was the development of a real-time engine model and the establishment of a meaningful task. The test matrix consisted of variations in the vehicle z-axis dynamics ($Z_y, Z_{\delta c}$), the engine response dynamics (ζ, ω_n), and available torque or excess power (T/W max); the remaining vehicle characteristics were unchanged. The vehicle simulated was an 8000-lb, two-bladed teetering-rotor helicopter, sufficiently augmented to yield a pilot rating of

2.5-3.0 for the tasks considered in this experiment. The stability derivative matrices for the baseline augmented configuration at 40 knots and hover are shown in Table 1.

Engine Model

The basis for the gas turbine engine model comes from a model developed for real-time simulation by Bell Helicopter¹⁰ and represents an XT-53 engine with the inertias for a UH-1C rotor and transmission system. A block diagram of the adaptation of that model for this study is shown in Fig. 3. Provisions are included for a pure time delay Δt and torque limiting Q_{lim} at the power turbine stage. By ignoring the nonlinearities in Δt and Q_{lim} , a transfer function with a second-order denominator can be generated (Fig. 3). As indicated in Ref. 10, most of the terms of that expression vary as a function of the gas generator speed N_1 ; for example, a range of 60-95% on N_1 for the XT-53 engine results in a range of frequencies of $\omega_n = 4-8$ rad/sec and a range of damping $\zeta = 0.6-1.1$. In this experiment, the engine terms were held constant for a given configuration and the configurations studied varied over a range of $\omega_n = 2-10$ rad/sec and $\zeta = 0.3-1.0$. In addition to frequency and damping, Q_{lim} was varied to provide a steady state (T/W) max. in hover ranging from 1.025 to 1.25. Bear in mind that actual transient thrust can exceed these limits via the stored energy in the rotor system.

Task and Simulation Set-Up

The determination of an appropriate task required the selection of one that would be minimally affected by such simulation limitations as limited field of view and limited motion cues and yet one that would place large demands on the engine and vertical axis. Both requirements were sufficiently satisfied by flying the course outlined in Fig. 4. The task consists of a constant-speed (40 knots) berm-hopping maneuver (called a "dolphin") followed by a deceleration to hover and then a bob-up maneuver. The pilot was requested to change altitude during the dolphin maneuver, primarily through collective control inputs. He was instructed to maximize his masking by crossing the four berms with minimal clearance and staying low between the berms. Because of a protective probe on the terrain board camera, a minimum scaled clearance of 17 ft was necessary. The pilot was provided with a software-generated radar altimeter reading to assist him in determining his altitude. After the fourth berm, the pilot performed a deceleration of his choosing in preparation for the bob-up maneuver. The hover bob-up required the sighting of three objects through 45° directional turns while maintaining maximum masking by the trees. The course was completed after the bob-down and reestablishment of a steady hover.

The pilot provided two Cooper-Harper pilot ratings for each run, one for the dolphin portion of the course and one for the bob-up portion. Evaluation of the deceleration segment was combined with the bob-up maneuver during the experiment when

changes were being made to the engine dynamics only and was evaluated separately during the time when changes were being made to the vehicle dynamics. The latter was necessary since Z_w varies as a function of speed and could only be specified at 40 knots and hover.

The cockpit instrument panel is shown in Fig. 5. The primary instruments the pilot included in his scan were radio altimeter, torque, rpm, and airspeed; an rpm warning light was added. The pilot also had an rpm "beep" trim switch, for his use on the collective grip.

Five pilots - two NASA test pilots, two Army test pilots, and an Army tactical pilot - participated in this experiment. Most configurations were evaluated by at least three of the pilots and were often repeated; there was a total of about 200 data runs.

Discussion of Results

The discussion that follows is based primarily on averaged pilot ratings and is presented in three subsections. Variations in the engine dynamics only, with the vehicle characteristics held at those described in Table 1, are discussed first. Data for variations in vehicle height damping Z_w and collective control sensitivity Z_{δ_c} , with the engine dynamics held constant, are discussed second, and trade-offs between engine response time and height damping for the bob-up maneuver are discussed last. Excess power requirements for specific tasks are also discussed in each subsection.

Effects of Engine Dynamics

As was shown in Fig. 3, the engine model in this study can be represented by an expression with a second-order denominator. It was through this representation that the engine response time and damping (i.e., ω , and ζ) were controlled. Alterations in ω_n and ζ in this model can be thought of as changes in the power train inertias, gas generator dynamics, and speed governor or power turbine gains. No attempt was made to isolate these terms specifically; instead the engine parameters were varied to provide an overall governed response in terms of the desired ω_n and ζ .

Figures 6 and 7 present the average pilot ratings for the engine configurations as a function of ω_n and ζ for unlimited T/W. Figure 6 presents data for the constant-speed dolphin maneuver, and Fig. 7 shows the results for the deceleration and hover bob-up maneuver. Also shown on these figures are the pilot ratings for the ideal governor (i.e., R held constant); this case resulted in pilot ratings of 2.5 for the dolphin and 3.0 for the bob-up.

Time histories of the thrust and torque responses to a 0.5-in. collective step for several engine models are shown in Fig. 8. The rpm and rate of climb responses are also shown; as can be seen, the slower governors have an effect of

increasing the \dot{h} rise time. The thrust responses all exhibit an immediate maximum thrust because of stored energy in the rotor followed by the transient behavior of the engine response and the \dot{h} damping owing to the rotor inflow and augmentation. Note that since the maximum thrust is achieved almost immediately, all the thrust responses satisfy the 0.3-sec level 1 Vertical Flight Characteristics (par. 3.2.5.2) criteria of MIL-F-83300 and the 0.5-sec rise time criteria of AGARD 577. However, the resulting pilot ratings for these governors in the bob-up varied from 3.0 for the ideal governor to 6.5 for engine configuration E27 (i.e., $\omega_n = 2.0$ rad/sec, $\zeta = 0.7$). Based on pilot commentary, these ratings reflected not only the changes to the vehicle response resulting from the engine dynamics but also reflected the attention required for undesirable governor droop and overspeed.

It should be noted that the data for the MIL-F-83300 thrust-response criteria were extracted from experiments based on configurations similar to the one shown in Fig. 1; therefore, they do not account for effects of rotor-speed control, stored energy, or inflow damping. Hence, since helicopter thrust responses, as described by Fig. 2, are quite different in nature, it is reasonable to expect that additional criteria to cover these responses are necessary. Perhaps a criterion based on vertical acceleration or on a frequency-domain approach would be more appropriate.

Several engine configurations (i.e., $\omega_n = 2, 4, 6,$ and 10 rad/sec) were studied at various levels of excess power, ranging from a steady state T/W = 1.025 to 1.25. Figure 9 shows how pilot ratings varied with changes in engine dynamics and T/W for the hover bob-up. The vertical damping was held at a fixed augmented level of $Z_w = -0.65$ sec⁻¹ and $Z_{\delta_c} = 0.38$ g/in. for hover. The engine response is depicted in terms of both frequency ω_n (at $\zeta = 0.7$) and the equivalent first-order time-constant τ_{eng} . Also shown in Fig. 9 is a line below which it was found that the engine power or torque limiting would likely occur sometime during the run. These data indicate that a satisfactory flying-qualities boundary is formed by T/W > 1.1 and an engine response of $\tau_{eng} < 0.2$ sec (i.e., $\omega_n \geq 7.0$ rad/sec). Based on time histories and pilot commentary, the lower bound on T/W was influenced by excessive power limiting, and the bound on engine response time τ_{eng} was dictated by excessive engine overspeed and underspeed, as well as sluggish response.

Effect of Vehicle Characteristics

In this segment of the experiment, variations in the vertical damping Z_w and collective control sensitivity Z_{δ_c} were studied. During this phase a highly responsive engine governor ($\omega_n = 10$ rad/sec) was used, thus keeping the effects of the engine response minimal and yet realistic. Vertical damping Z_w was varied through stability augmentation of the basic speed-dependent aerodynamic damping which was -0.25 sec⁻¹ in hover. A range of $Z_w = 0$ to -4 sec⁻¹ in hover was studied.

Figures 10 and 11 show how pilot ratings varied with Z_w and Z_{δ_c} . The results for the 40-knot dolphin task are shown in Fig. 10 along with an approximate pilot rating (PR) = 3.5 fit to the data. Also shown are the characteristics of the basic simulation model and several current generation helicopters.¹¹ As can be seen, all of these basic configurations lie outside of the PR = 3.5 region determined by this experiment. These data indicate a need with this task for a higher damping and sensitivity than currently provided.

The results for the hover bob-up maneuver are shown on Fig. 11. The PR = 3.5 contours for these data along with those of several previous near-hover studies are also given. The current results describe a subset of the previous results, favoring, in general, higher sensitivities. The current results and the low-speed handling-qualities criteria given in MIL-F-83300 and AGARD 577 are compared in Fig. 12. Also shown are the characteristics of several helicopters including the unaugmented model used in this experiment. The results from this study do fall within the MIL-F-83300 Level 1 boundaries; however, for the hover bob-up task, they indicate a need for a higher minimum for both damping and sensitivity.

The effects of vertical damping (Z_w) on excess power requirements (T/W) has been addressed in Refs. 1, 3, and 4, and form the basis for the criteria given in MIL-F-83300. Figure 13 shows the data from this experiment for the hover bob-up maneuver. The solid lines on that figure are the criteria as given by MIL-F-83300. These criteria are for a vehicle whose vertical damping is composed of an aerodynamic contribution only (i.e., $Z_w = Z_{w_a}$). The damping of the vehicle in this experiment is represented by both an aerodynamic and stability augmentation contribution (i.e., $Z_w = Z_{w_a} + Z_{\delta_c} (K_{\delta_c/w})$). In the case of a helicopter model, however, the aerodynamic damping can be further broken down into at least the inflow and fuselage contributions (i.e., $Z_{w_a} = Z_{w_{fus}} + Z_{w_{inflow}}$) where in hover the inflow damping is predominant (i.e., $Z_{w_a} = Z_{w_{inflow}}$). For the model used in this experiment the aerodynamic damping in hover is -0.25 sec^{-1} and hence $Z_{w_a} = Z_{w_{inflow}} = -0.25 \text{ sec}^{-1}$. From the time histories shown in Fig. 8 and from the diagram shown in Fig. 2, it can be seen that the inflow damping and stability augmentation damping cause the thrust response to decay, and since the steady-state value of thrust returns to its original level, it can be concluded that $Z_{fus} = 0$ (i.e., $Z_w = Z_{w_a} + Z_{w_{inflow}}$). Since the criteria of MIL-F-83300 is intended for comparison with the portion of damping which does not cause thrust decay (e.g., $Z_{w_{fus}}$), one is led to conclude that the data from this experiment should be compared with boundaries based on an inherent damping equal to zero. These MIL-F-83300 boundaries are shown in Fig. 8. However, a further look at the time histories in Fig. 8 indicates that while the thrust response returns to the original level, the torque response (i.e., engine output) does not. This peculiarity, along with the stored energy in the rotor, makes a comparison of helicopter data with the MIL-F-83300 boundaries

questionable. However, what can be said of the data shown is that the required level of T/W does depend on Z_w and is minimized at a total damping of $Z_w = -0.8$ to -1.0 sec^{-1} in hover.

Trade-Offs between Vertical Damping Z_w and Engine Response τ_{eng}

A final segment of this experiment studied the trade-off between engine response (τ_{eng}) and damping (Z_w) on the overall height response of the vehicle. First consider the representation given in Fig. 1. This configuration consists of two cascaded first-order systems, which can be approximated by a single first-order time-constant and is shown by \bar{Z}_w in Table 2. Several lines of constant \bar{Z}_w resulting from that table are plotted in Fig. 14. Also shown in Fig. 14 are the results of Ref. 5, which show a satisfactory boundary (i.e., $PR \leq 3.5$) for a trade-off between τ_{eng} and Z_w . Although that study did not address the idea of an equivalent \bar{Z}_w , it can be seen that the boundary lies along a constant \bar{Z}_w of -1.0 sec^{-1} . This treatment implies that by maintaining an equivalent damping of greater than -1.0 sec^{-1} , satisfactory flying qualities can be obtained. Such a trade-off of Z_w for τ_{eng} represents a considerable departure from the MIL-F-83300 Level 1 criteria shown in that figure.

Now consider the representation given in Fig. 2. Exploring the possible trade-off between engine response and vertical damping for a helicopter is not as straightforward because of the complex nature of the thrust response, which, in general, cannot be characterized by a first-order time-constant τ_T . A closer look at the time histories in Fig. 8, however, shows that the engine governor does have an effect on the \dot{h} response and hence on the effective damping Z_w . Specifically, the engine configuration E67 ($\tau_{eng} = 0.23 \text{ sec}$) causes an increase in \dot{h} rise time (i.e., time to 63%) of from 1.5 sec, for the ideal case, to 1.8 sec. This results in a decrease in effective damping of from -0.65 sec^{-1} to -0.56 sec^{-1} . A further decrease in effective damping can be noted in the distorted \dot{h} response for the engine configuration E27 ($\tau_{eng} = 0.7 \text{ sec}^{-1}$). Thus a trend in equivalent or effective damping exists for Fig. 2 which is similar in nature to that shown for Fig. 1. However, the results for this case, which are shown in Fig. 15, indicate a far more restrictive trade-off between τ_{eng} and Z_w than is shown in Fig. 14. As was indicated earlier, an upper limit on τ_{eng} exists which is determined more by tolerable levels of engine overspeed and underspeed than by resulting \dot{h} response.

Conclusions

The effects of vertical axis response on the handling qualities of an rpm-governed helicopter operating in an NOE environment were studied. The results from this motion-based simulation show several areas where present handling-qualities criteria need extension or modification. The following trends or conclusions are summarized:

1) An engine governor response of 0.2 sec or faster is required for satisfactory flying qualities and rpm control for the tasks performed in this experiment.

2) In addition to engine response time an excess power level of $T/W > 1.1$ is required during the bob-up. This excess power level is a function of Z_w and is minimized at a Z_w of between -0.8 and -1.0 sec^{-1} .

3) For satisfactory flying qualities there is a restricted trade-off between engine response time and vehicle damping; however, increases in engine time-constant are limited by poor rpm overspeed and underspeed control.

4) The results from this experiment indicate that higher minimums for both Z_w and Z_{δ_c} are required for these NOE tasks than are specified by MIL-F-83300 and AGARD 577.

5) The thrust response for an rpm-governed helicopter cannot be compared directly with the thrust response time-constant criteria of MIL-F-83300. The helicopter thrust response is composed of a combination of stored energy, governed response, and inflow damping, and hence cannot be characterized as a first order; thus a new criterion is needed.

References

1. Gerdes, R. M., and Weick, R. F., "A Preliminary Piloted Simulator and Flight Study of Height Control Requirements for VTOL Aircraft," NASA TN D-1201, 1962.
2. Garren, J. F., Jr., and Assadourian, A., "A VTOL Height-Control Requirement in Hover as Determined from Motion Simulator Study," NASA TN D-1488, 1962.
3. Gerdes, R. M., "A Piloted Motion Simulator Investigation of V/STOL Height-Control Requirements," NASA TN D-2451, 1964.
4. Kelly, J. R., and Garren, J. F., Jr., "Flight Investigation of V/STOL Height-Control Requirements for Hovering and Low-Speed Flight under Visual Conditions," NASA TN D-3977, 1967.
5. Vinje, E. W., and Miller, D. P., "Analytical and Flight Simulation Studies to Develop Design Criteria for VTOL Aircraft Control Systems," AFFDL-TR-68-165, Apr. 1969.
6. A'Harrah, R. C., and Kwiatkowski, S. F., "A New Look at V/STOL Flying Qualities," Aerospace Engineering, 20 (7), July 1961, pp. 22-23, 86-92.
7. Hoh, R. H., and Ashkenas, I. L., "Development of VTOL Flying Qualities Criteria for Low Speed and Hover," NADC-77052-30, Dec. 1979.
8. Vinje, E. W., and Miller, D. P., "Flight Simulator Experiments and Analyses in Support of Further Development of MIL-F-83300 - V/STOL Flying Qualities Specification," AFFDL-TR-73-34, June 1973.
9. Parrish, R. V., et al., "Empirical Comparison of a Fixed-Base and a Moving-Base Simulation of a Helicopter Engaged in Visually Conducted Slalom Runs," NASA TN D-8424, 1977.
10. Sonneborn, W., and Torres, I., "UH-1C Data for Hybrid Computer Simulation," Report 204-099-892, Bell Helicopter Company, undated.
11. Heffley, R. K., et al., "A Compilation and Analysis of Helicopter Handling Qualities Data," Vol. I, NASA CR-3144, 1979.

Table 1. Baseline Augmented Configuration

40 Knots									
F matrix is:									
U	W	Q	THETA	V	P	PHI	R		
-.67094E-01	.63303E-02	.12532E 02	-.19605E 02	-.93550E-03	-.94208E 00	.54309E-01	.18724E 01		
-.16087E 00	-.10555E 01	.92916E 02	.20898E 02	-.26210E-01	-.28947E 01	-.97003E 00	.55438E 00		
.11542E-01	.28087E-02	-.29061E 01	-.22198E 01	.14908E-03	.14730E 00	-.44039E 02	.37028E-02		
.00000E 00	.00000E 00	.10000E 01	.00000E 01	.00000E 00	.00000E 00	.00000E 00	.00000E 00		
-.14550E-01	-.37659E-02	-.23983E 00	.61808E 00	-.15947E 00	-.43990E 01	.22246E 02	-.63077E 02		
-.56975E-02	-.10780E-02	-.25133E 00	.50135E 00	-.92668E-02	-.49574E 01	-.62792E 01	.69372E 00		
.00000E 00	.00000E 00	.00000E 00	.00000E 00	.00000E 00	.10000E 01	.00000E 00	.48996E-01		
.52419E-02	.16625E-02	-.25227E 00	.31119E 00	.23276E-01	-.87597E 00	-.86469E 00	-.40001E 01		

G matrix is:

DELTA E	DELTA C	DELTA A	DELTA P
-.19903E 01	.67605E 00	-.39219E-02	.22316E-01
-.38370E 01	-.12363E 02	-.11006E-01	-.33018E-02
.35294E 00	-.58116E-02	-.69883D-03	-.48941E-03
.00000E 00	.00000E 00	.00000E 00	.00000E 00
-.13503E 00	-.77366E-01	.18137E 01	-.99206E 00
.90781E-02	-.57286E-01	.10868E 01	-.25149E 00
.00000E 00	.00000E 00	.00000E 00	.00000E 00
.18877E 00	-.34315E-02	.24901E-01	.72604E 00

$$\dot{X} = FX + GU$$

F matrix is:

Hover									
U	W	Q	THETA	V	P	PHI	R		
-.73200E-01	-.17236E-01	.16619E 02	-.18397E 02	.76353E-03	-.99232E 00	.17848E-01	-.67649E-01		
.37640E-01	-.65021E 00	.14357E 00	-.13880E 01	-.39558E-01	.67401E-01	-.32754E 00	-.25043E-01		
.11312E-01	.64809E-02	-.27200E 01	-.22171E 01	.19824E-03	.15302E-00	-.82793E-03	-.38976E-01		
.00000E 00	.00000E 00	.10000E 01	.00000E 01	.00000E 00	.00000E 00	.00000E 00	.24197E-02		
-.65185E-02	-.56082E-02	-.96860E 00	.52645E-02	-.13565E 00	-.69056E 01	.22318E 02	.37598E 01		
-.55066E-03	.28817E-02	-.81417E 00	.11131E-02	-.14528E-01	-.45552E 01	-.62638E 01	.62447E 00		
.00000E 00	.00000E 00	-.10730E-03	.00000E 00	.00000E 00	.10000E 01	.00000E 00	.44342E 01		
.71576E-02	.14523E-01	-.55445E 00	.77832E-04	.13836E-01	-.10268E 01	-.92055E 00	-.36767E 01		

G matrix is:

DELTA E	DELTA C	DELTA A	DELTA P
-.22040E 01	.53581E 00	.00000E 00	.88440E-04
-.95908E-02	-.12090E 02	-.31445E 03	.00000E 00
.35720E 00	-.31973E-02	-.12692E-02	.78661E-02
.00000E 00	.00000E 00	.00000E 00	.00000E 00
-.34403E-01	-.16805E 00	.18064E 01	-.10006E 01
.93418E-01	-.97817E-01	.10870E 01	-.25364E 00
.00000E 00	.00000E 00	.00000E 00	.00000E 00
.24561E 00	.37786E-01	.35604E-01	.73235E 00

Table 2. Equivalent damping for configuration in Fig. 1.

τ_{eng} (sec)	ω_n at $\zeta = 0.7$ (rad/sec)	Damping - Z_{wa} (sec ⁻¹)						
		0	-0.5	-1.0	-1.5	-2.0	-3.0	-4.0
1.4	1	0	-0.3	-0.42	-0.52	-0.6	-0.71	-0.71
0.71	2	0	-0.42	-0.59	-0.73	-0.84	-1.03	-1.4
0.5	3	0	-0.5	-0.71	-0.87	-1.0	-1.22	-1.73
0.35	4	0	-0.5	-0.84	-1.04	-1.2	-1.46	-2.07
0.23	6	0	-0.5	-1.0	-1.3	-1.47	-1.81	-2.55
0.18	8	0	-0.5	-1.0	-1.45	-1.67	-2.04	-2.89
0.14	10	0	-0.5	-1.0	-1.48	-1.9	-2.31	-3.27

\bar{Z}_w

Case I Case II Case III

$\frac{1}{\tau_{eng}} \geq 5 Z_{wa}$ $\frac{1}{\tau_{eng}} \approx Z_{wa}$ $Z_{wa} \geq 5 \frac{1}{\tau_{eng}}$

$\bar{Z}_w \approx Z_{wa}$ $\sqrt{\frac{Z_{wa}}{4 \tau_{eng}}}$ $\frac{1}{\tau_{eng}}$

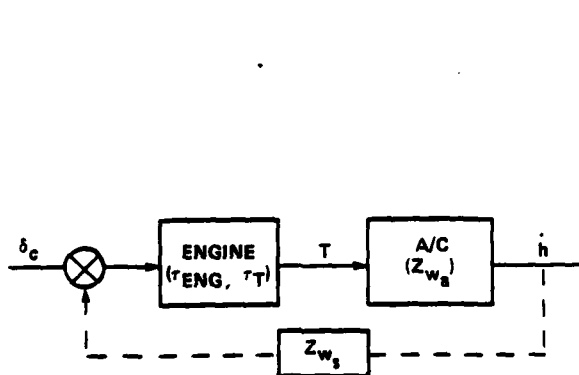

Fig. 1. VTOL (jet lift) vertical control.

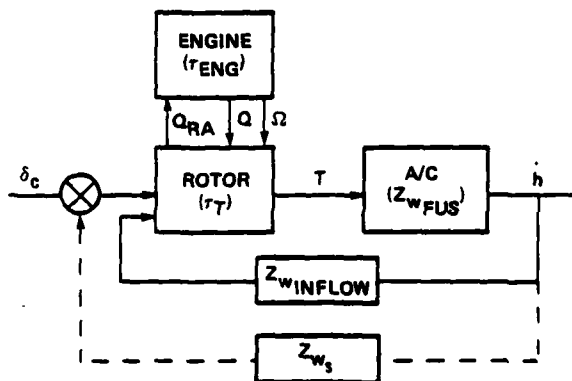
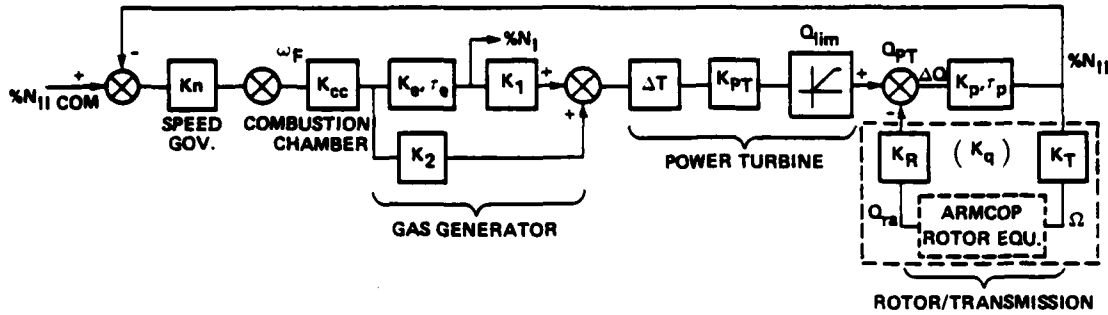

Fig. 2. Helicopter vertical control.



$$\frac{\%N_{11}}{\Delta Q} \propto \frac{s + 1/\tau_e}{s^2 + \underbrace{(1/K_p + 1/\tau_e + K_{PT} K_n K_{CC} K_2 + K_q)}_{2\zeta\omega_n} s + \underbrace{\left(\frac{1}{\tau_e K_p} + \frac{K_{PT} K_n K_{CC} K_1 K_e}{\tau_e} + \frac{K_p K_n K_{CC} K_2}{\tau_e} + \frac{K_q}{\tau_e}\right)}_{\omega_n^2}}$$

• T-53 ENGINE WITH UH-1C

$\zeta = 0.6 - 1.1$

$\omega_n = 4 - 8 \text{ rad/sec}$

Fig. 3. Engine model.

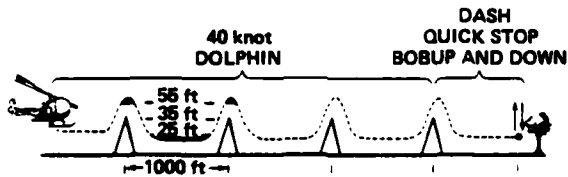

Fig. 4. Simulation task.

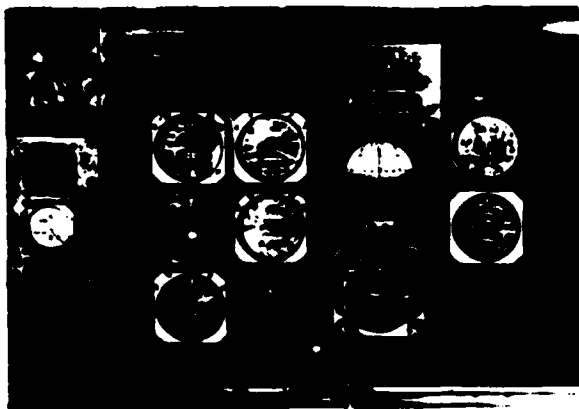

Fig. 5. Cockpit instrumentation.

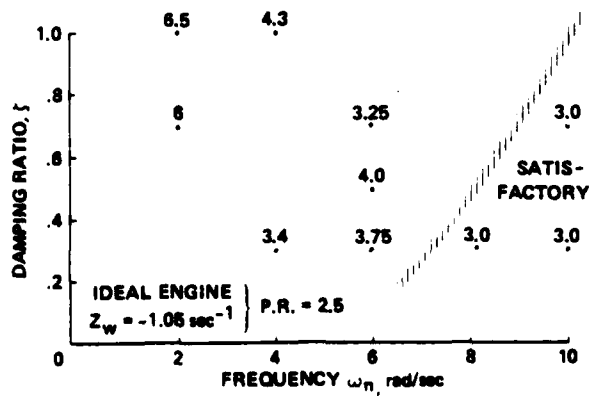

Fig. 6. Effects of engine frequency and damping - dolphin.

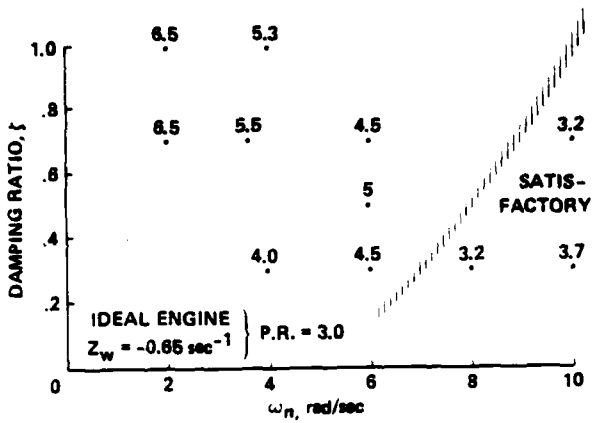

Fig. 7. Effects of engine frequency and damping - quick stop/bob-up.

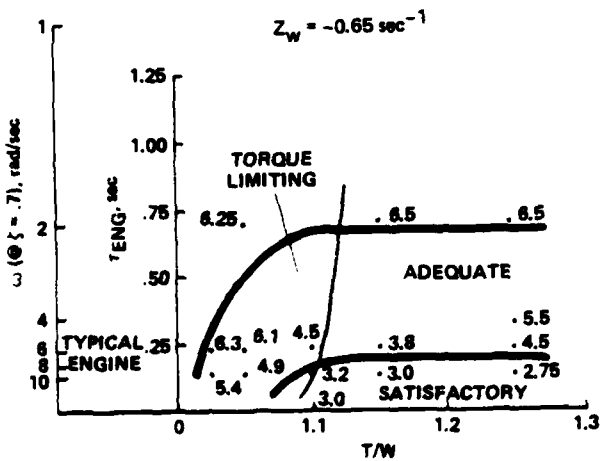

Fig. 9. Engine response time versus T/W - bob-up maneuver.

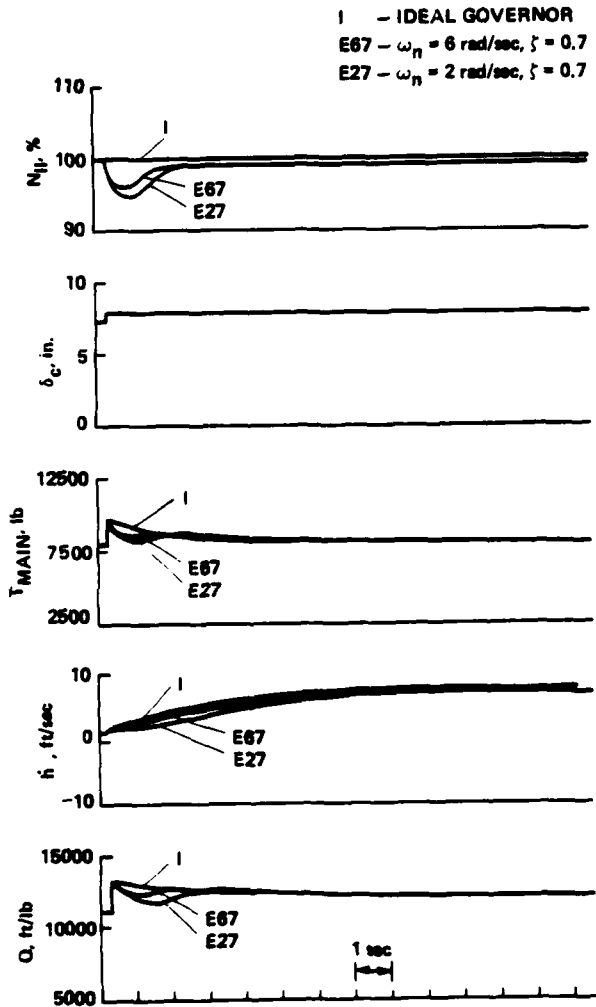

Fig. 8. Engine response time histories; collective steps ($Z_w = -0.65 \text{ sec}^{-1}$).

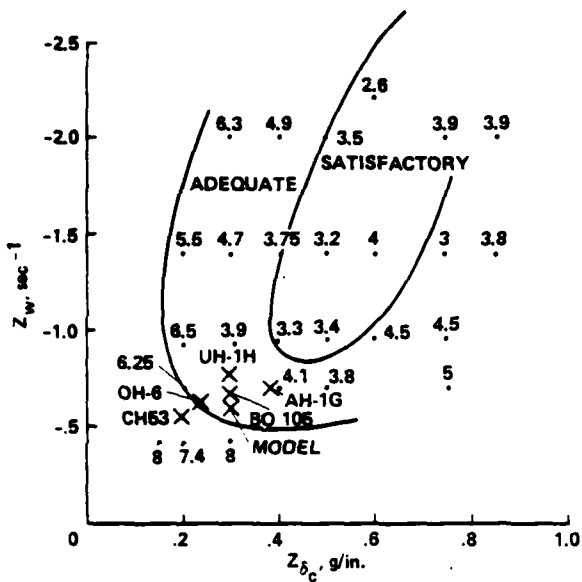

Fig. 10. Vertical damping and collective sensitivity - dolphin maneuver.

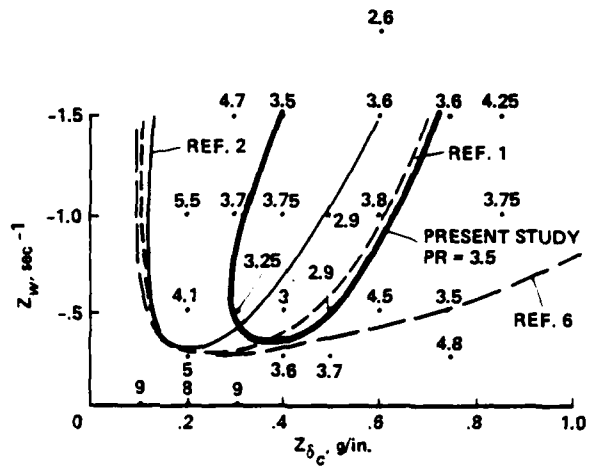

Fig. 11. Vertical damping and collective sensitivity - bob-up maneuver.

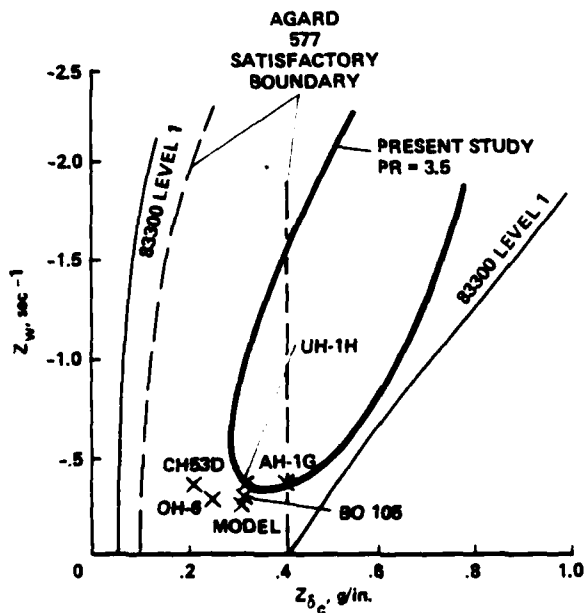

Fig. 12. Comparison of bob-up data with existing criteria.

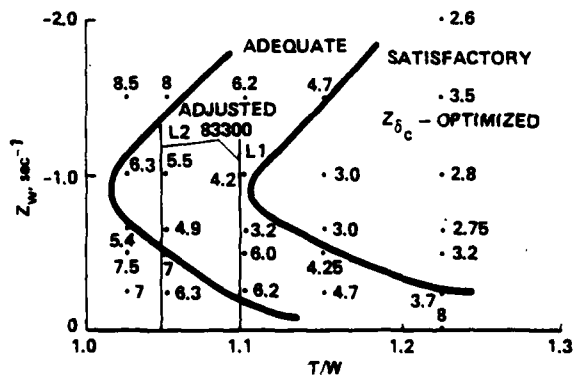

Fig. 13. Vertical damping and T/W - bob-up maneuver.

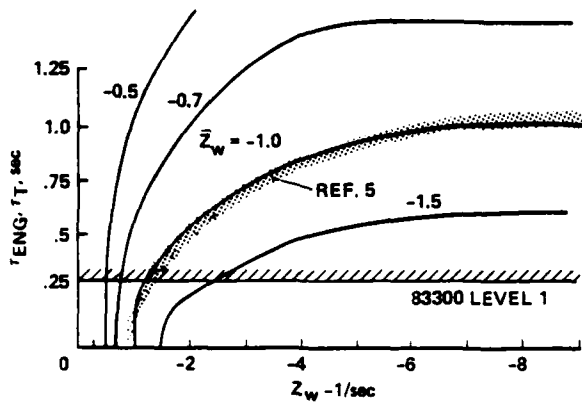

Fig. 14. Trade-off between Z_w and τ_T for configurations of Fig. 1.

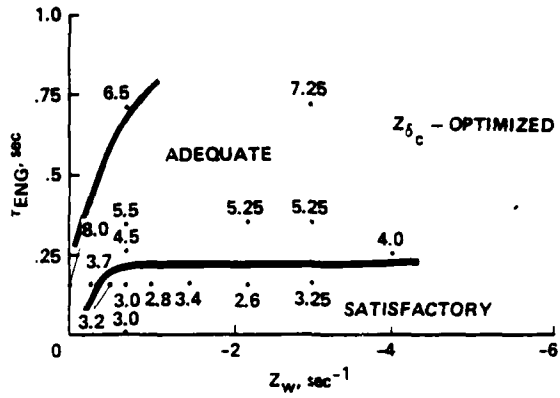

Fig. 15. Trade-off between Z_w and τ_{eng} for the hover bob-up.

DATE
ILME