

AD A118603

Journal of Wind Engineering and Industrial Aerodynamics, 9 (1982) 193-205
Elsevier Scientific Publishing Company, Amsterdam — Printed in The Netherlands

193

①

WIND VS. WIND TUNNEL: THE AERODYNAMICS OF THE INLET FOR NASA'S NEW, VERY LARGE, NONRETURN-FLOW FACILITY

WILLIAM T. ECKERT

Research Support Division, Aeromechanics Laboratory, U.S. Army AVRADCOM Research and Technology Laboratories, Ames Research Center, Moffett Field, California 94035 (U.S.A.)

KENNETH W. MORT

NASA-Ames Research Center, Moffett Field, California 94035 (U.S.A.)

(Received December 12, 1978; accepted July 15, 1981)

Summary

The National Aeronautics and Space Administration is currently modifying the 40- by 80-foot subsonic wind tunnel at Ames Research Center. This modified facility will go a long way toward meeting the projected need for improvements in the capabilities of ground-based aeronautical facilities. A major concern during design development has been the effect of the external wind on the quality (uniformity) of the flow in the test section of the new open-return test circuit. Wind-effects studies on model wind tunnels have developed a relatively complex inlet treatment which should assure good test-section flow quality under most wind conditions. However, the experimental program, coupled with on-site wind measurements, has also demonstrated that even a minimum treatment can ensure adequate testing capabilities in the presence of the prevailing local winds, and that test programs will not be significantly affected.

Notation

- A cross-sectional area of test section
 D_h hydraulic diameter of test section, $4 A/P$
 P perimeter of cross-section of test section
 V_0 mean test-section airflow velocity
 Δu maximum axial velocity deviation, due to wind effects, from mean test-section airflow velocity (measured over central 47% of test-section area)
 Δv maximum lateral velocity deviation, due to wind effects, from perfect axial flow (positive starboard) (measured over central 47% of test-section area)
 Δw maximum vertical velocity deviation, due to wind effects, from perfect axial flow (positive up) (measured over central 47% of test-section area)
 ψ wind direction relative to centerline of wind-tunnel inlet (positive for wind from port)

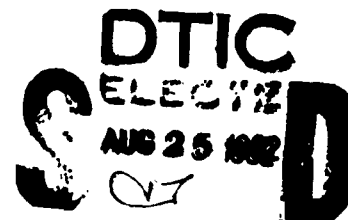

DTIC FILE COPY

Background

The record of aeronautical contributions over the past 35 years has proved the value of full-scale aerodynamic testing and of the NASA-Ames 40- by 80-Foot Wind Tunnel. Recent inter-agency studies have identified the requirement for major improvements in full-scale testing capabilities. Specifically, the needs lie in the areas of increased test-section size and airspeed. Design studies determined that the most cost-effective means of achieving the desired improvements was the repowering and expansion of the existing 40- by 80-foot wind tunnel (see refs. 1 and 2).

Figure 1 shows the planned modifications. Repowering the drive system

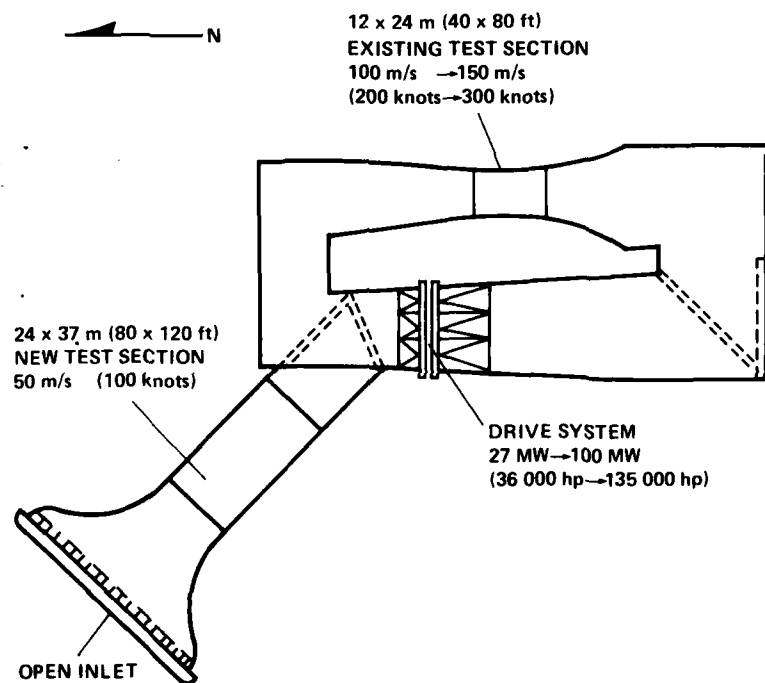

Fig. 1. Modifications to the 40- by 80-foot wind tunnel.

from 27 to 100 MW (36 000 to 135 000 h.p.) will increase the maximum airspeed in the test section of the existing, closed-return circuit from 100 to 150 m s^{-1} (200 to 300 kt). A larger test-section, 24 by 37 m (80 by 120 ft.), will be added in a new, nonreturn-flow test leg with an open inlet facing northwest.

The nonreturn circuit was selected over a closed-circuit alternative after

careful consideration of the relative merits of aerodynamic (energy) efficiency, protection of internal flow from external winds, community noise and visual impact, and construction costs. The simplicity and economy of the open inlet were the primary points in its favor. The effects of the local wind on testing capability and programs, as measured by the test-section flow quality (uniformity), were a major concern due to their impact on the ultimate utility of the new addition.

Flow quality requirements

After careful study of the unique requirements of V/STOL aircraft operation and testing, criteria were established [3] for the flow quality required in any such aeronautical facility, be it either open or closed return. The very simple criteria are shown in Fig. 2. Lateral and vertical velocity deviations

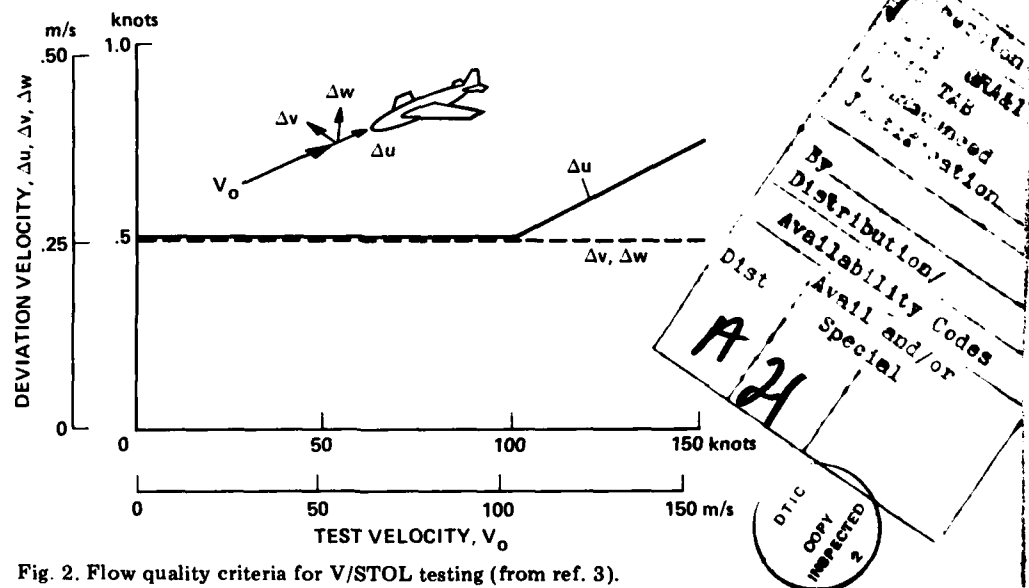

Fig. 2. Flow quality criteria for V/STOL testing (from ref. 3).

from the mean no-wind condition are restricted to $\pm 0.25 \text{ m s}^{-1}$ ($\pm 0.5 \text{ kt}$). Axial velocity deviations have the same restriction up to test speeds of 50 m s^{-1} (100 kt). At airspeeds greater than 50 m s^{-1} (100 kt) the axial deviations may be no greater than 0.5% of the test speed. It was these criteria against which the inlet protection systems and wind effects were evaluated.

Model studies

With the minimum acceptable flow quality having been defined by the

criteria of ref. 3 and Fig. 2, an extensive series of model tests was undertaken to compare and evaluate the relative merits of various amounts and types of inlet treatment in the presence of a wide variety of wind conditions. Powered models of nonreturn-flow facilities were placed in the existing test section of the 40- by 80-foot wind tunnel which was used as the wind source (Fig. 3

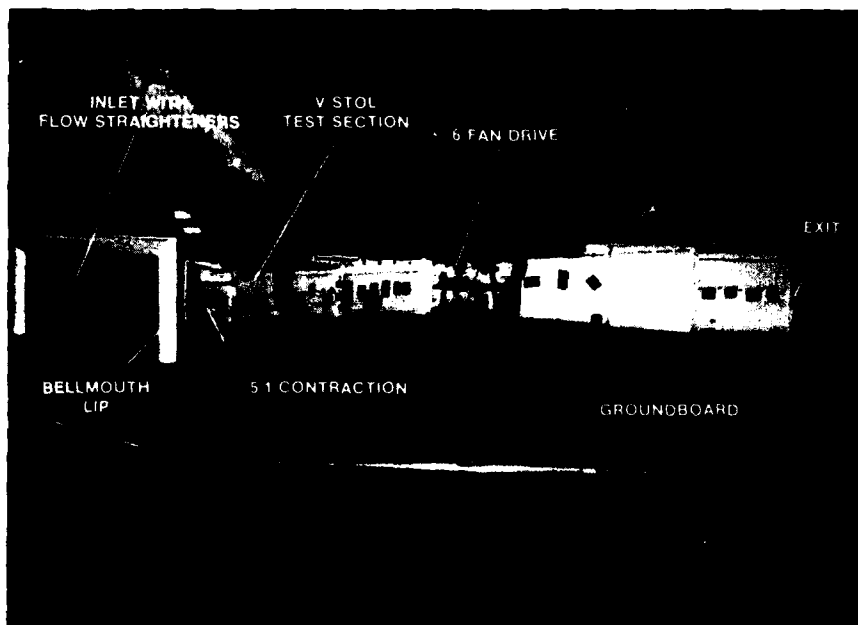

Fig. 3. 1/50-Scale model of modified facility with minimum-protection inlet installed in 40- by 80-foot wind tunnel.

shows one such model, a 1/50-scale simulation of the modified facility). Then, by varying the relative flow speeds of the model and "wind" and by changing the model orientation, the effects of different winds were measured for the several configurations.

These studies involved only the effects of steady-state winds having a uniform velocity distribution. It was concluded from other studies [4,5] that the steady-state wind was the critical problem and that wind gusts produced only a small effect on the turbulence of the test-section flow. Limited studies were performed with the model on the floor with the boundary layer artificially thickened to simulate the Earth's boundary layer for wind over flat open country [6]. These studies indicated that the velocity profile was not important and that a uniform velocity equal to that at the wind-tunnel centerline could be used to establish wind effects on the test-section flow quality.

Two examples of inlet configurations tested are shown in Fig. 4. (More-

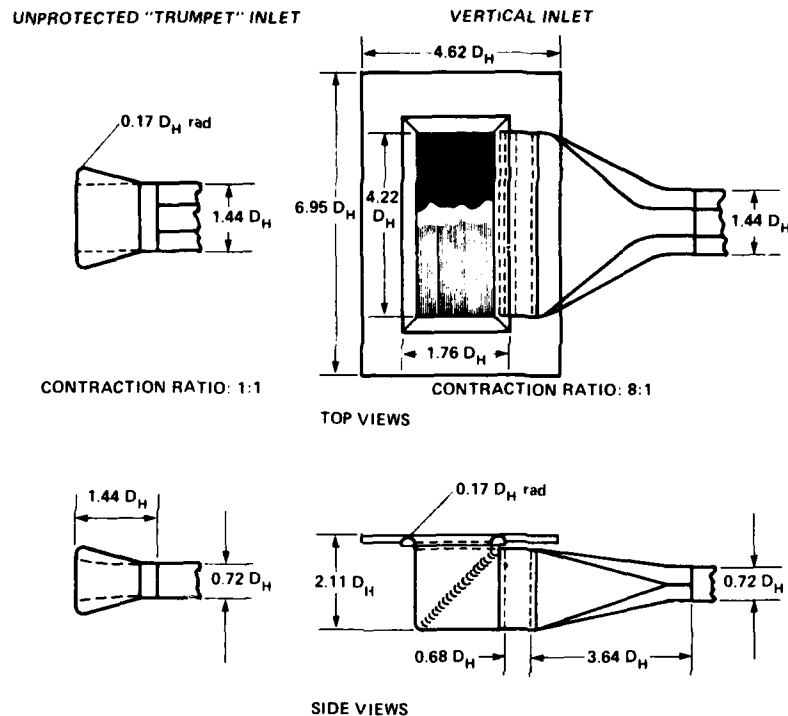
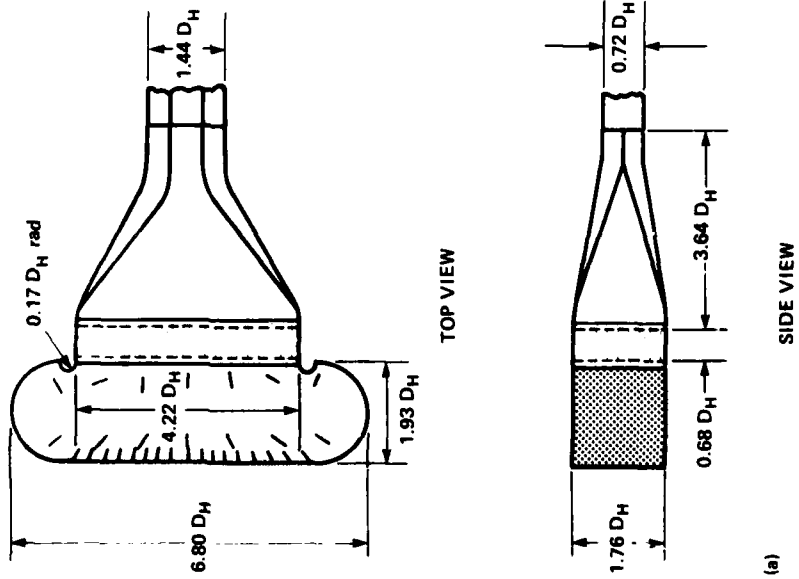
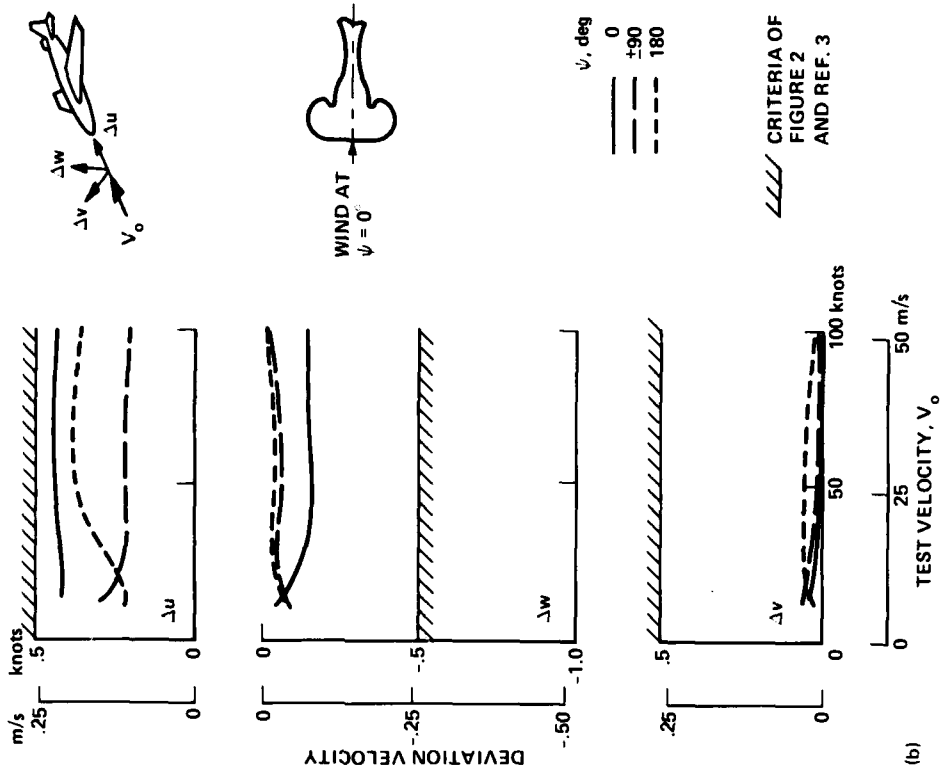

Fig. 4. Samples of inlet protection systems tested in model studies; D_H = hydraulic diameter of test section (see ref. 9 for more details).

complete details and the results of the experimental program are reported in refs. 7–9.) The “trumpet” inlet was completely unprotected and its performance was poor; the flow quality was much worse than the acceptable limits of the criteria for many reasonable external wind conditions. The vertical inlet treatment improved the flow quality from that in the unprotected case. However, the model test-section flow quality satisfied the criteria only down to a test velocity of $\sim 20 \text{ m s}^{-1}$ (40 kt) — not sufficiently low for adequate V/STOL testing. Further improvements in flow quality were achieved by the development of a horizontal inlet with a screened shield in front, as shown in Fig. 5(a).

This horizontal inlet, discussed in greater detail in ref. 3, incorporated a large, screened “room” with a solid roof supported by aerodynamically faired and aligned posts, and two sets of flow-straightener grids. As shown in Fig. 5(b), for test-section flow speeds down to 5 m s^{-1} (10 kt) this system provided good protection from 5 m s^{-1} (10 kt) winds, meeting all the criteria.

This developed treatment was almost as complex as it was effective and a simpler inlet protection was desired. The selected inlet configuration, shown



(a)

(b)

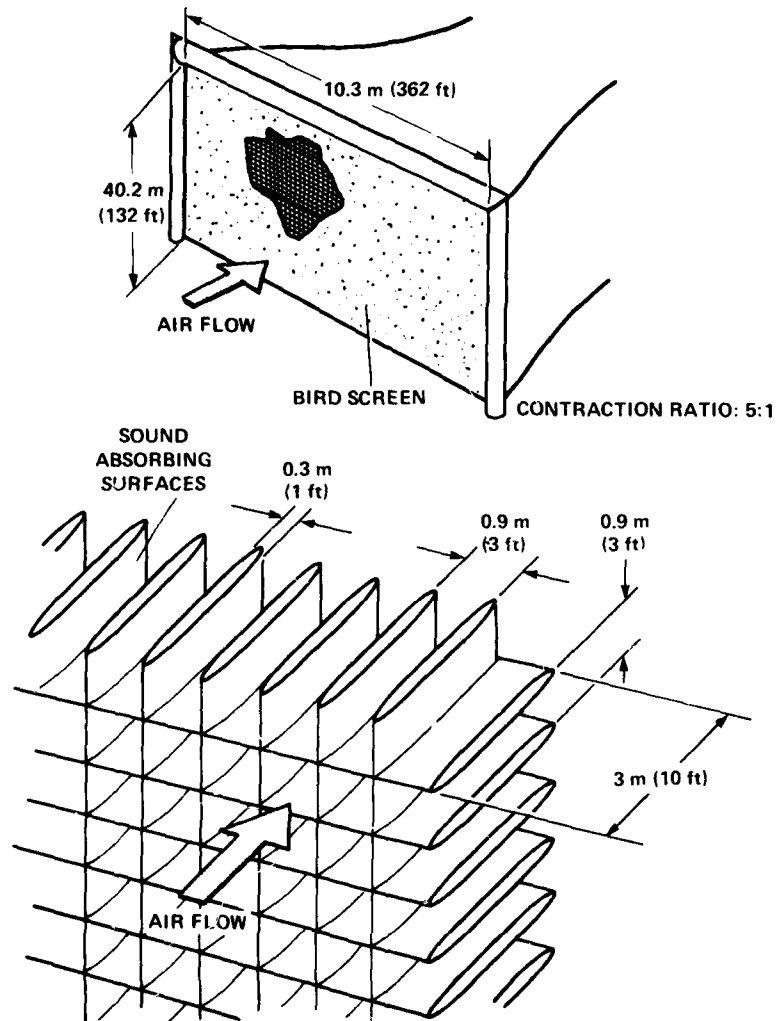

Fig. 6. Inlet flow-straightener and acoustic-baffle system for the selected minimum-protection inlet.

Fig. 5. Horizontal inlet-protection system for good wind protection: (a) geometry of treatment; contraction ratio 8:1, D_H = hydraulic diameter of test section; (b) inlet performance measured at wind speed of 5 m s^{-1} (10 kt).

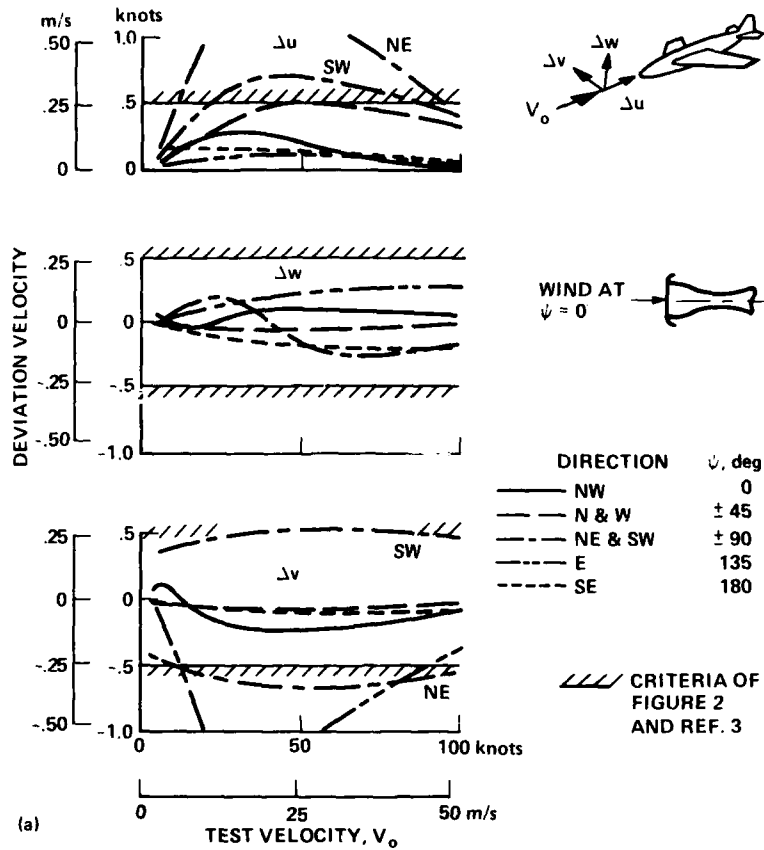
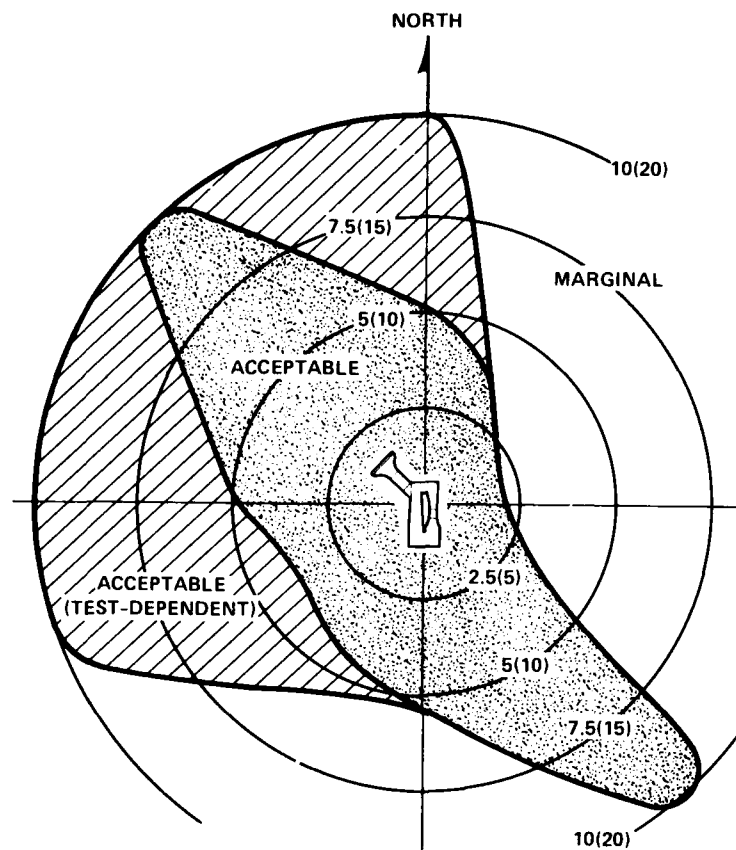

Fig. 7. Performance of minimum-protection inlet: (a) measured deviation velocities in the presence of 5 m s^{-1} (10 kt) winds; (b) wind tolerance regions.

in Fig. 6, is relatively simple, having no shielding upstream of the contraction inlet face. There will be a combination flow-straightener and acoustic-baffle grid and a bird screen at the inlet of a contraction having an area ratio of five to one.

The wind sensitivity of this minimum-protection inlet was studied extensively. Representative results are shown in Fig. 7. As shown in Fig. 7(a), at a wind speed of 5 m s^{-1} (10 kt) and for many directions, the flow quality was good. For a few cases the flow quality criteria were exceeded. Figure 7(b) gives a more pictorial representation of this inlet's tolerance to external wind. There is a significant region where winds up to 10 m s^{-1} (20 kt) and within $\sim 5^\circ$ from the inlet centerline are acceptable. A larger quadrant of wind may be acceptable, within the criteria, depending on the particular requirements and test



WIND SPEEDS, m/s (knots)

(b)

envelopes of specific wind-tunnel programs. The remainder of the possible wind conditions would be "acceptable" only with relaxed flow quality criteria and reduced data accuracy.

The series of model studies determined the wind conditions under which an open wind-tunnel inlet, particularly one with minimum protection, might operate productively. However, in the final analysis, the acceptability of the selected inlet design was dependent on the actual wind conditions at the Ames site.

Site studies

Wind measurements were taken at the site of the planned facility extension for integration with the model wind-tunnel test results. A tower was erected at the location of the inlet face. Propeller-driven sensors were placed at the quarter-height points of the inlet. (The inlet centerline is at an elevation of 18 m.) Data were recorded at the site over a period of about two years.

The measured wind direction and time patterns are shown in Fig. 8(a). For the summer and fall months (represented respectively by August and November) the predominant wind is from the northwest quadrant. In the

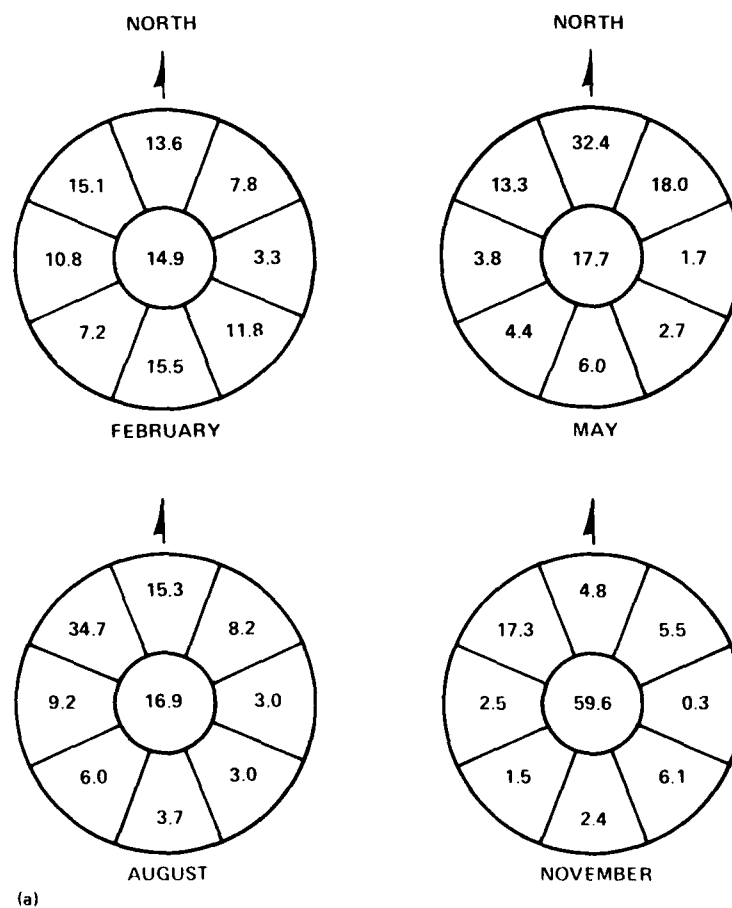
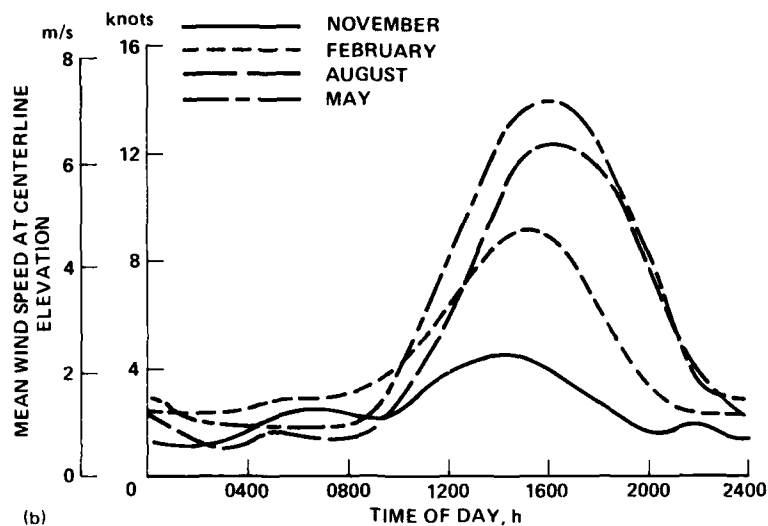

Fig. 8. Wind patterns at facility site, elevation 18 m (60 ft.): (a) wind roses showing direction-time patterns; (b) day-to-day repeatability of wind patterns.



winter (February), south and southeast winds increase during stormy weather, and in the late spring (May) there is a significant incidence of north winds. But regardless of the time of year, the wind speed patterns are highly repeatable from day to day. As Fig. 8(b) shows, the mean wind speed always peaks at a relatively low level around mid-afternoon, gradually increasing before and decreasing after the peak. Thus, the winds at Ames are generally predictable, relatively low in magnitude, and often from the northwest quadrant. These and other, more detailed, site wind data gave a good understanding of the wind conditions to be expected during the future operation of the facility.

Impact of winds on testing programs

The combined data from the model and site studies showed that the planned minimum-protection wind-tunnel inlet, in the presence of the observed Ames winds, will achieve an acceptable level of flow quality in the new V/STOL test section. Figure 9 shows the average available testing time as a function of time of day. Generally, ~25% of day- and swing-shift working hours are required for actual tunnel-on testing. (The balance of the time is devoted to model preparation, instrument checkout, and configuration changes.) For the majority of the year the time of acceptable winds (i.e., with test-section flow quality within the criteria of ref. 3 and Fig. 2) well exceeds the time required. Only in the spring would wind be likely to affect the test schedule. However, even in the spring, a little care expended in scheduling is expected to overcome most problems with wind effects.

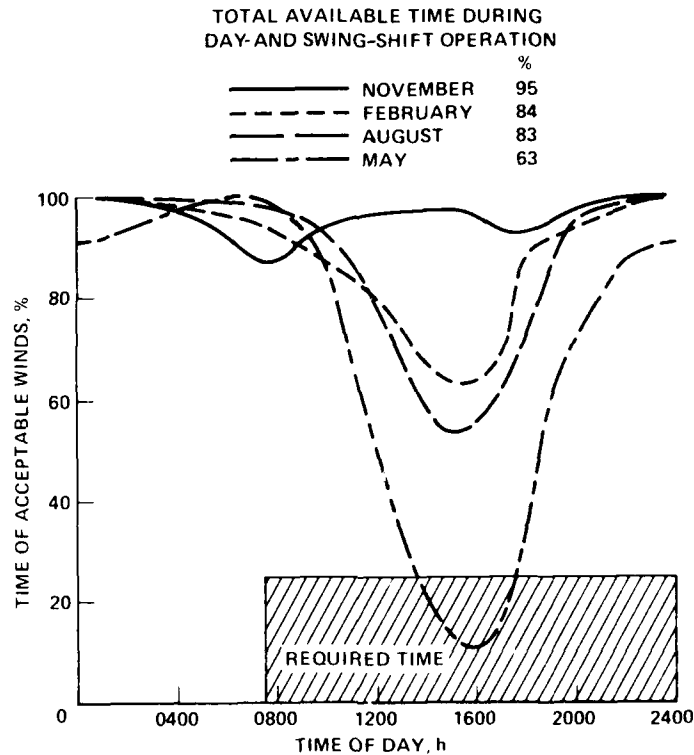

Fig. 9. Impact of Ames winds on testing time available in new nonreturn circuit.

Concluding remarks

External winds are a real and potentially severe concern for nonreturn wind tunnels; however, various protection systems have been developed which minimize the effects of large winds on test-section flow quality. Fortunately, Ames Research Center has relatively low and predictable winds in which to operate the 40- by 80-/80- by 120-foot wind tunnel. A combination of model and site wind studies has demonstrated that even with minimal inlet protection, this facility will prove to be an extremely valuable aeronautical tool. During periods of wind conditions exceeding those provided for in the system design, the scheduling of testing times can be modified. Should testing, program, or schedule requirements change and more inlet treatment be needed in the future, the technology now exists.

References

- 1 Kenneth W. Mort, Mark W. Kelly and David H. Hickey, The rationale and design features for the 40- by 80-/80- by 120-foot wind tunnel, Pap. 9, Proc. AGARD Conf. on Wind-tunnel Design and Testing Techniques, March 1976, AGARD CP-174.
- 2 Kenneth W. Mort, Paul T. Soderman and William T. Eckert, Improving large-scale testing capability by modifying the 40- by 80-foot wind tunnel, *J. Aircraft*, 16 (1979) 571-575.
- 3 K.W. Mort, W.T. Eckert and M.W. Kelly, Steady-state flow quality of an open return wind tunnel model, *Can. Aeronaut. Space J.*, 18 (1972) 285-289 (also NASA Tech. Memo. TM X-62, 170 (1972)).
- 4 C.R. Leef and R.G. Hendry, Development of a nonrecirculating wind-tunnel configuration insensitive to external winds, *J. Aircraft*, 6 (1969) 221-227.
- 5 Douglas C. Breunlin and Noel B. Sargent, Effect of transient winds on the flow quality of an open-circuit wind-tunnel model, NASA Tech. Memo. TM X-2538 (1972).
- 6 A.G. Davenport, The relationship of wind structure to wind loading, *Compil. Pap. presented at NASA Langley Res. Center Meet. on Ground Wind Load Problems in Relation to Launch Vehicles*, June 7-8, 1966, NASA Tech. Memo. TM X-57, 779 (1966) pp. 10.1-10.20.
- 7 William T. Eckert, Kenneth W. Mort and J.E. Piazza, Wind-sensitivity studies of a non-return wind tunnel with a 216- by 432-mm (8.5- by 17.0-in.) test section - Phase I, NASA Tech. Memo. TM X-62, 171 (1972).
- 8 William T. Eckert, Kenneth W. Mort and J.E. Piazza, Wind-sensitivity studies of a non-return wind tunnel with a 216- by 432-mm (8.5- by 17.0-in.) test section - Phase II, NASA Tech. Memo. TM X-62, 307 (1973).
- 9 William T. Eckert, Kenneth W. Mort and J.E. Piazza, An experimental investigation of end treatments for non-return wind tunnels, NASA Tech. Memo. TM X-3402 (1976).