

12

SAR-82-10082-02

AD A118654

HgCdTe FABRICATION USING DIRECTED ENERGY TECHNIQUES

**ROBERT WOLFSON
(617) 275-6000 EXT. 283**

**ANTON GREENWALD
(617) 275-6000 EXT. 227**

**JULY 1982
Semiannual Report**

**THIS RESEARCH WAS SPONSORED BY THE DEFENSE ADVANCED
RESEARCH PROJECTS AGENCY UNDER ARPA ORDER NO. 3800
CONTRACT NO.: MDA 903-81-C-0410
MONITORED BY: MR. SVEN ROOSILD, DARPA/MSO
1400 WILSON BLVD., ARLINGTON, VA 22209**

**EFFECTIVE DATE: 1 JULY 1982
EXPIRATION DATE: 31 AUGUST 1983**

Approved for Public Release: distribution unlimited

DTIC FILE COPY

DTIC
SELECTED
AUG 27 1982
S **D**
H



The views and conclusions contained in this document are those of the author and should not be interpreted as necessarily representing the official policies, either expressed or implied, of the Defense Advanced Research Projects Agency or the United States Government.

DISTRIBUTION

Director
Defense Advanced Research Projects Agency
1400 Wilson Boulevard
Arlington, VA 22209

Attn: Program Management (3)
Attn: Dr. Richard A. Reynolds (1)
Attn: Mr. Sven Roosild (1)

Defense Documentation Center (12)
Cameron Station
Alexandria, VA 22314

Spire Corporation Distribution

A. Greenwald (1)
R. Little (1)
R. Wolfson (1)
Files Original + (6)

NERC Distribution

T. Wong (1)
R. Martineau (1)
C. Devaney (1)
Files (1)

Accession For	
NTIS GPO	<input checked="" type="checkbox"/>
DTIC TAB	<input type="checkbox"/>
Unannounced	<input type="checkbox"/>
Justification	
By _____	
Distribution/	
Availability Codes	
Availability For	
Dist	
A	

DTIC
COPY
INTEGRATED
2

FOREWORD

The work reported in this document was performed in part at Spire Corporation, Bedford, Massachusetts, and in part at New England Research Center, Inc., Sudbury, Massachusetts, under contract MDA 903-81-C-0410, DARPA Order Number 3800. The contract monitor is Mr. Sven Roosild.

The program manager at Spire is Dr. Robert Wolfson. The principal investigator at Spire is Dr. Anton Greenwald, who is in charge of pulsed electron beam processing. The program manager at NERC is Dr. Theodore Wong. The project engineer at NERC is Dr. Robert Martineau, and the task engineer is Mr. Chris Devaney, who is in charge of the epitaxial deposition and vapor exchange processes.

The report of the main subcontractor, NERC, is included in Section 2. Work performed at Spire Corporation is described in Section 3.

SUMMARY

The goal of this work is to produce thin single-crystal films of HgCdTe at least 2 inches in diameter for use in infrared detectors.

Single-crystal films of CdTe have been deposited on 1-inch diameter mica substrates using the new furnace by the hot wall epitaxy technique. CdTe films were deposited on sapphire substrates with excellent morphology and stoichiometry, but with a polycrystalline structure. Limited regions (0.5 mm across) were monocrystalline, and experiments are continuing. The CdTe source material was analyzed, and a maximum impurity concentration of 0.1 ppm was detected.

A CdTe film on sapphire was converted to $\text{Hg}_{1-x}\text{Cd}_x\text{Te}$ by evaporation and diffusion at constant temperature (EDICT). This film had a uniform composition but was also polycrystalline. Previous results (on mica substrates) have shown that single-crystal HgCdTe films can be fabricated by the HWE/EDICT process with electron mobility as high as $1.5 \times 10^5 \text{ cm}^2/\text{V-sec}$ at 77°K .

Pulsed electron beam polishing has now been demonstrated for complete coverage of a 1-inch diameter CdTe film. Larger samples could be processed but were not available. Experiments for fabrication of HgCdTe films by evaporation and pulse electron beam diffusion are in progress.

TABLE OF CONTENTS

<u>Section</u>		<u>Page</u>
1	INTRODUCTION	1-1
	1.1 Long Term Objective	1-1
	1.2 General Method	1-1
	1.3 Summary of Current Status	1-2
2	REPORT OF SUBCONTRACTOR NERC (HETEROEPITAXY OF CdTe VIA HWE	2-1
	2.1 Process Description	2-1
	2.2 New HWE Apparatus	2-2
	2.3 HWE System Calibration	2-5
	2.4 Deposition	2-13
	2.5 Edict on Sapphire	2-16
	2.5.1 HgCdTe Growth by Vapor Exchange and Diffusion	2-16
	2.5.2 Conversion of CdTe to HgCdTe on Sapphire Substrates	2-20
	2.6 Characterization of Films	2-20
	2.7 Substrate Preparation	2-23
	2.8 CdTe Source Analysis	2-26
3	REPORT OF MAIN CONTRACTOR, SPIRE CORPORATION	3-1
	3.1 Pulsed Electron Beam Processing (PEB) of Heteroepitaxial Films	3-1
	3.1.1 CdTe Films	3-1
	3.1.2 HgCdTe Films	3-1
	3.2 PEB Processing of Amorphous/Polycrystalline Films	3-1
	3.2.1 Objective	3-1
	3.2.2 Apparatus	3-2
	REFERENCES	R-1

LIST OF ILLUSTRATIONS

<u>Figure</u>		<u>Page</u>
2-1	CdTe on Mica Existence Region	2-3
2-2	Old Vacuum HWE System	2-4
2-3	New Hot Wall Epitaxy System	2-6
2-4	Bottom Plate	2-7
2-5	Slider Bottom	2-8
2-6	Top Slider Plate	2-9
2-7	Temperature Gradient Reversal	2-12
2-8	Structure Coarsening Due to Orientation	2-15
2-9	Coarse Texture of CdTe on Sapphire Grown at $\Delta T = 65^{\circ}\text{C}$	2-17
2-10	CdTe Films Deposited on Sapphire by HWE	2-18
2-11	Growth Rate vs. ΔT at $T_{\text{source}} = 45^{\circ}\text{C}$	2-19
2-12	Transmission Curves for Sapphire and HgCdTe on Sapphire	2-21
2-13	Back Reflection Laue X-Ray Diffraction Pattern From HgCdTe Film (Polycrystalline) on Sapphire (Single-Crystal) Substrate	2-22
2-14	Morphology and Crystallite Size of CdTe on Sapphire Grown at Higher Source Temperature	2-24
2-15	Single Crystal CdTe Embedded in Polycrystalline Matrix	2-25
3-1	Apparatus for Co-Evaporation of Hg and Te and Pulsed Process In Situ	3-3

SECTION 1 INTRODUCTION

1.1 LONG TERM OBJECTIVE

The overall purpose of this program is to grow large, single-crystal $\text{Hg}_{1-x}\text{Cd}_x\text{Te}$ suitable for use in large-scale detector arrays. The following material properties are design goals for this program:

- Compositional uniformity $\Delta x < 0.0006$
- Two-inch diameter, heteroepitaxial single-crystal films
- Net foreign impurity concentration $< 5 \times 10^{14}$ atoms/cm³

The program objective also includes the demonstration that the process developed is capable of producing crystals with the aforementioned properties in sufficient quantities to be able to meet the future needs of DOD through the 1980's.

1.2 GENERAL METHOD

The method used in this program attains the desired end of large-area, uniform, single-crystal HgCdTe films in two steps. The first step is to grow heteroepitaxially large single-crystal films of CdTe on foreign substrates by the Hot Wall Epitaxy (HWE) technique. The second step is transformation from single-crystal CdTe film to single-crystal HgCdTe film by a process of vapor growth and solid state diffusion known as EDICT (Evaporation and Diffusion at Constant Temperature).

This two-step method has a number of advantages over other methods of growing large-area HgCdTe single-crystal specimens. First, the film thickness is determined by the deposition of the CdTe in the initial step, whereas the critical Hg-Cd ratio is determined by the second step. This process allows critical parameters to be separately optimized. Second, since all processes take place at relatively low temperatures, the excessive mercury pressure that plagues most high-temperature melt-growth processes is not a problem. In fact, this method takes advantage of the volatility of components and grows from the vapor phase. Scaling up of the specimen dimensions is rather straightforward relative to melt-growth methods, which are all limited by the 1/2 inch

ampoule dimension as a result of high mercury pressures. Third, segregation problems which limit the uniformity of composition in melt-grown HgCdTe do not exist in this method, because melting is not required here. Furthermore, since HgCdTe is grown directly in a thin CdTe film, no compositional gradient occurs. Thus, exceptionally uniform composition should result both across and normal to the film surface. Finally, both the HWE and the EDICT processes are vapor-growth methods where the emphasis is placed on the growth of epitaxial layers under conditions as near as possible to thermodynamic equilibrium, resulting in thin films of bulk quality and crystalline perfection.

An additional processing step is necessary to produce a smooth surface. The growth morphology of the as-deposited CdTe film after HWE is faceted, with surface relief greater than one micron. The surface features after EDICT to HgCdTe show many spiral growth terraces. How the surface morphology of the HgCdTe film relates to that of the original CdTe sample is not yet known. Polishing a thin film is difficult and costly. However, rapid melt and quenching by irradiation with a pulsed electron beam produces a superior surface finish. As the surface cools after melt, epitaxial crystal growth prevents degradation of the structure. The short time at high temperature, less than one microsecond, minimizes outdiffusion of the volatile components. This process can be used either before or after EDICT. The process is fast, noncontaminating, inexpensive, and amenable to large-scale manufacture.

1.3 SUMMARY OF CURRENT STATUS

During this reporting period, at NERC, the new HWE system was set up and calibrated. Seventeen new CdTe films were deposited, 10 of which were on sapphire substrates. Samples were analyzed by microscopy and Laue back-reflection x-ray patterns. The immediate goal is to determine the parameter region for depositing single-crystal CdTe films on sapphire. Samples prepared to date have been fine-grained polycrystalline material with only limited regions (about 0.5 mm across) possibly single crystal.

Also during this period a preparation process was developed for sapphire substrates on three different crystallographic planes. The CdTe source material for the HWE process was analyzed by spark source mass spectrometry (SSMS), and the largest concentration reported for a significant impurity (Ca) was 0.1 ppma. One CdTe film on mica was converted by EDICT to HgCdTe, and initial optical transmission data are reported.

During this time period, at Spire Corporation, CdTe and HgCdTe films on mica were processed with a pulsed electron beam (PEB). Initial results were reproduced. The HgCdTe film was not stoichiometric as received; additional samples of HgCdTe on mica have been obtained for further tests, as well as two samples of CdTe on sapphire. The apparatus for co-evaporation of Hg and Te onto a liquid nitrogen cooled CdTe substrate (to be followed by PEB epitaxial regrowth) has been completed and calibrated.

SECTION 2
REPORT OF SUBCONTRACTOR NERC
(HETEROEPITAXY OF CdTe VIA HWE)

2.1 PROCESS DESCRIPTION

The first step in this process is the epitaxial growth of thin CdTe films (10 um) on suitable substrates. The technique employed for the vapor deposition is known as the Hot Wall Epitaxy (HWE) process.

In essence, the HWE process involves thermal evaporation of a pure CdTe source in a hot-walled airtight enclosure and subsequent epitaxial growth of CdTe on a heated foreign substrate.

Several factors must be considered in any vapor growth process involving CdTe. First, CdTe evaporates according to the reaction:



The component partial pressures of Cd and Te₂ vapors are not necessarily equivalent and, in fact, for a stoichiometric CdTe source, they differ by an order of magnitude at typical sublimation temperatures; Cd being the greater at 10⁻³ torr. Hence, stoichiometry of the deposit must be considered. Secondly, CdTe is known to grow in several different polymorphic forms, the two most commonly observed being the cubic (sphalerite) and hexagonal (wurtzite) forms. Thus, controlled nucleation must be maintained as well.

In the HWE process a source of stoichiometric CdTe is maintained at a temperature T₂ in an airtight enclosure (the HWE growth chamber) and the substrate is maintained at a slightly lower temperature T₁. The temperature differential T₂ - T₁ (ΔT) is maintained by independent control of the source and substrate temperature. The enclosure walls are also heated at T₂ to preserve stoichiometry. Source evaporation proceeds according to the decomposition reaction (1). Vapor transport occurs in response to the temperature gradient ΔT and results in vapor saturation near the substrate at temperature T₁. By adjusting the overall magnitude of the temperature differential, the nucleation and growth rates can be controlled to yield high-quality, single crystal films with minimum defects.

In the HWE process, the overall stoichiometry of the grown film is preserved even in light of gross component partial pressure differences because (1) the deposition takes place in an airtight enclosure under near equilibrium partial pressures; (2) deposition rates are maintained at reasonably low levels so that desorption and reaction takes place slowly on the surface of the growing film; and, (3) substrate temperature is maintained high enough to enhance surface diffusion which promotes stoichiometric balance.

2.2 NEW HWE APPARATUS

During the latter part of the first half of this program a new HWE system was designed. It was evident from earlier work that the lack of control over process parameters such as source to substrate temperature differential, growth time, and the inability to maintain quasi-equilibrium conditions within the growth enclosure seriously limited our ability to produce single crystal CdTe thin films with reproducible properties on any foreign substrate except mica. Since the existence region for single crystal growth (the relationship between source and substrate temperature) for CdTe on basal plane mica substrates is quite broad (see Figure 2.1), it was possible to produce single crystal films routinely with minimal control over process variables. However, on other substrates such as BaF₂ and sapphire, CdTe has a much narrower single crystal existence region and it becomes necessary to be able to provide control and stability of process parameters over narrow limits. For this reason, a new HWE system capable of providing the necessary control and stability was designed and built.

The old HWE system as shown in Figure 2.2, consisted of a dual furnace spirally wound on a grooved quartz core. Temperature regulation was supplied by controlling the voltage applied to the source and substrate heaters using variacs. This, of course, was subject to line voltage fluctuations, constantly increasing temperatures with time and no control of the initial heat up and final cool down rates.

The substrate holder and vapor enclosure consisted of a series of quartz inserts that fit inside the dual furnace assembly. The substrate size was limited by the enclosure diameter and was slightly greater than 1 inch. Because the substrate was tightly surrounded by the enclosure and closely followed by the furnace, there was no possibility of including a shutter in order to isolate the substrate from the source during heat up or cool down. This made actual growth-rate determination impossible and introduced error in identifying where growth was initiated in the cycle.

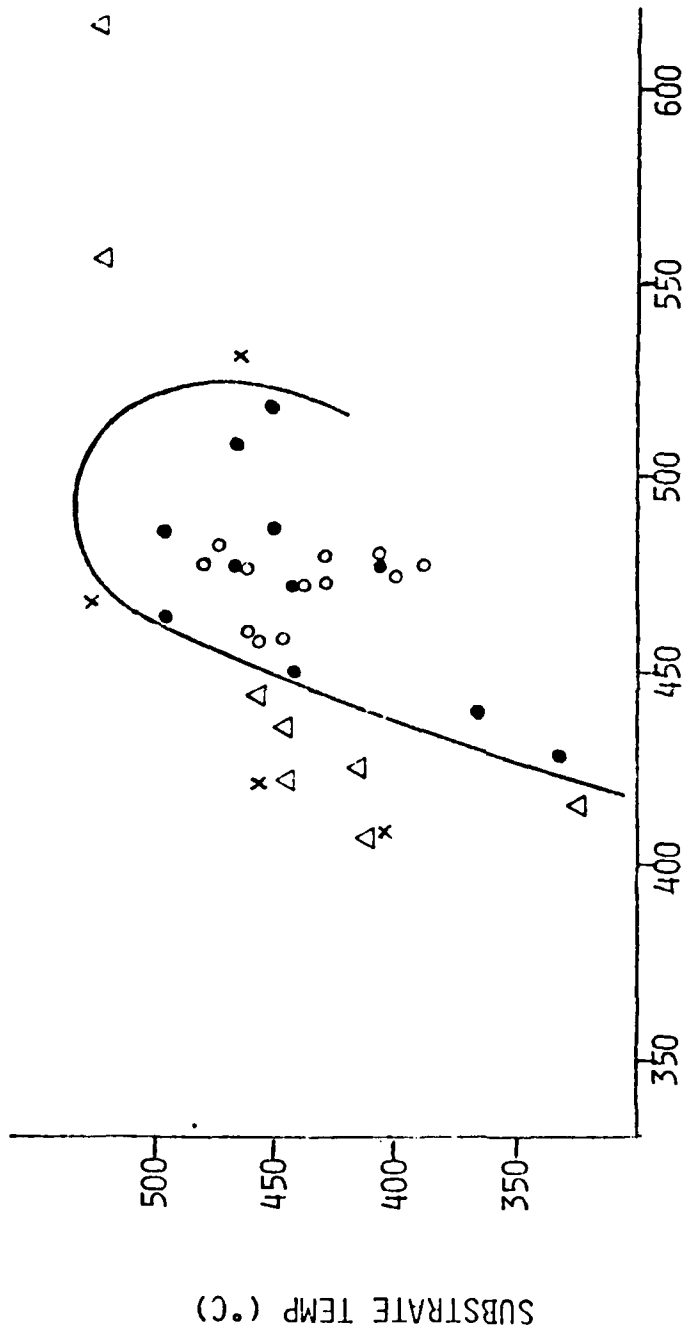

FIGURE 2-1. CdTe ON MICA EXISTENCE REGION

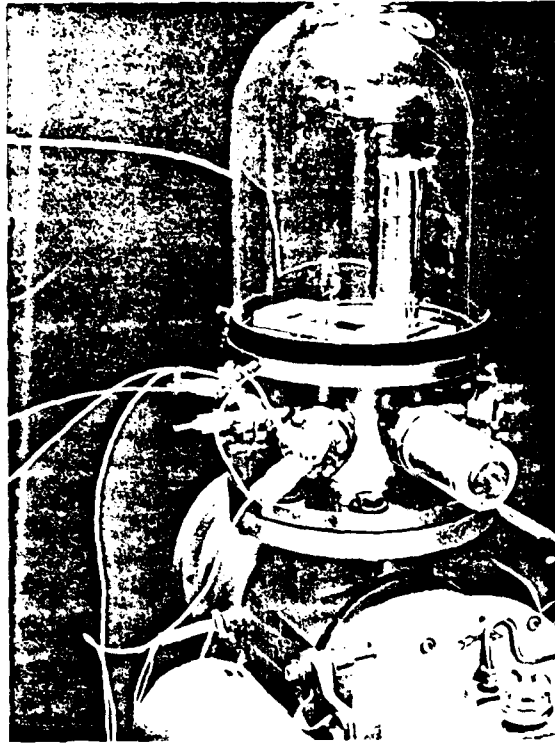

FIGURE 2-2. OLD VACUUM HWE SYSTEM

To circumvent these programs and to allow for gradual increase in substrate size, a new HWE system was designed and built. The new system is shown in Figure 2-3. It contains three individually controlled heaters; two heaters wound across 7-inch diameter flat quartz discs which act as source and substrate heaters (i.e., bottom and top heaters) plus a spirally wound wall heater wound on a 4-inch diameter by 2.5-inch high quartz tube. Temperature is controlled at a source and substrate locations by separate solid state digital controllers while the wall furnace is regulated by a separate variac. The unit shown in Figure 2-3 replaces the old furnace in the same bell jar shown in Figure 2-2.

Figures 2-4, 2-5, and 2-6 are manufacturing drawings for the base plate (source holder, Figure 2-4) and substrate slider assembly (Figures 2-5 and 2-6). A major improvement over the old HWE system is the ability to position the substrate in a growth or non-growth position at any time during a run so that accurate growth rates and growth times may be determined. This is accomplished by having the top slider plate (Figure 2-6) locate in the grooves of the slider bottom (Figure 2-5). The top slider is connected to a pulley system which is operated via a magnetic rotor feedthrough connected to the vacuum station. The bottom plate, slider bottom, top slider plate, and some other minor attachments not shown in the diagrams are machined from high purity densified graphite, a material known to be inert to CdTe.

The major advantages of the new HWE system are:

- Precise temperature control
- Substrate positioning system (analogous to a shutter system)
- Capable of accepting 2-inch diameter substrates
- Permanent thermocouples at source and substrate locations

2.3 HWE SYSTEM CALIBRATION

The new HWE system was assembled, outgassed at 700°C under vacuum, and calibrated. Calibration was performed by depositing CdTe films on 1-inch diameter mica substrates under identical thermal conditions as used in the earlier CdTe on mica work. In this regard seven (7) growth iterations were performed. In the first six attempts only occasionally was any growth observable (see Table 2-1) and in these cases only marginal

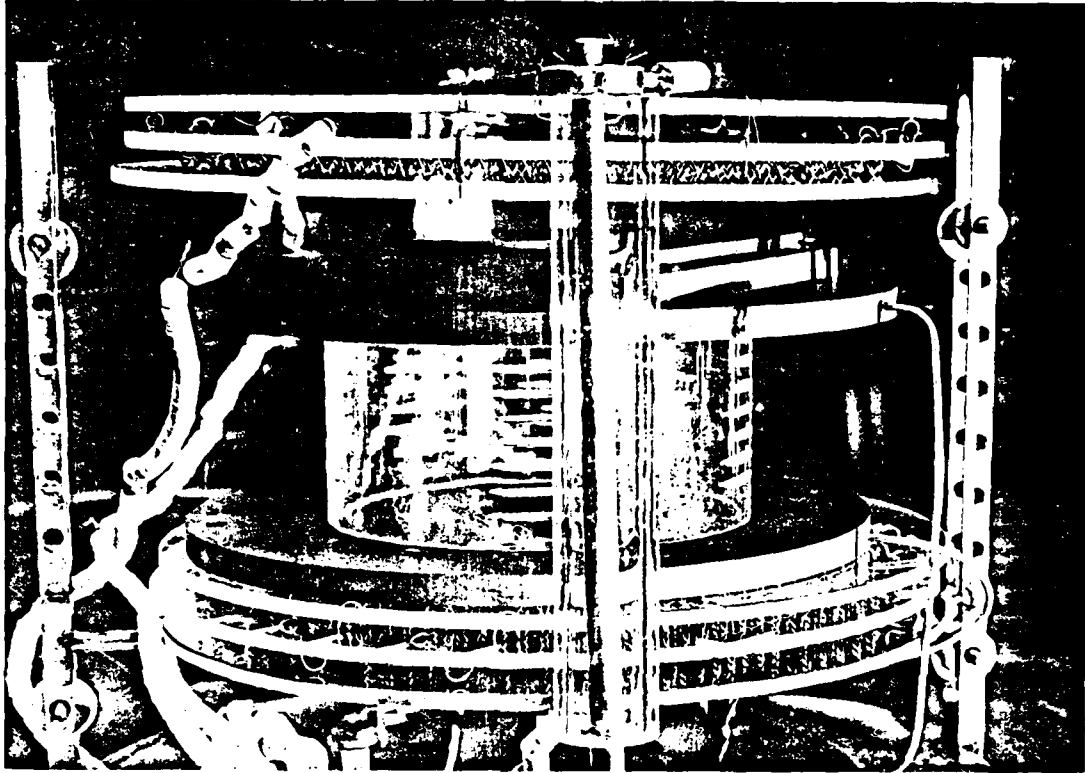

FIGURE 2-3. NEW HOT WALL EPITAXY SYSTEM

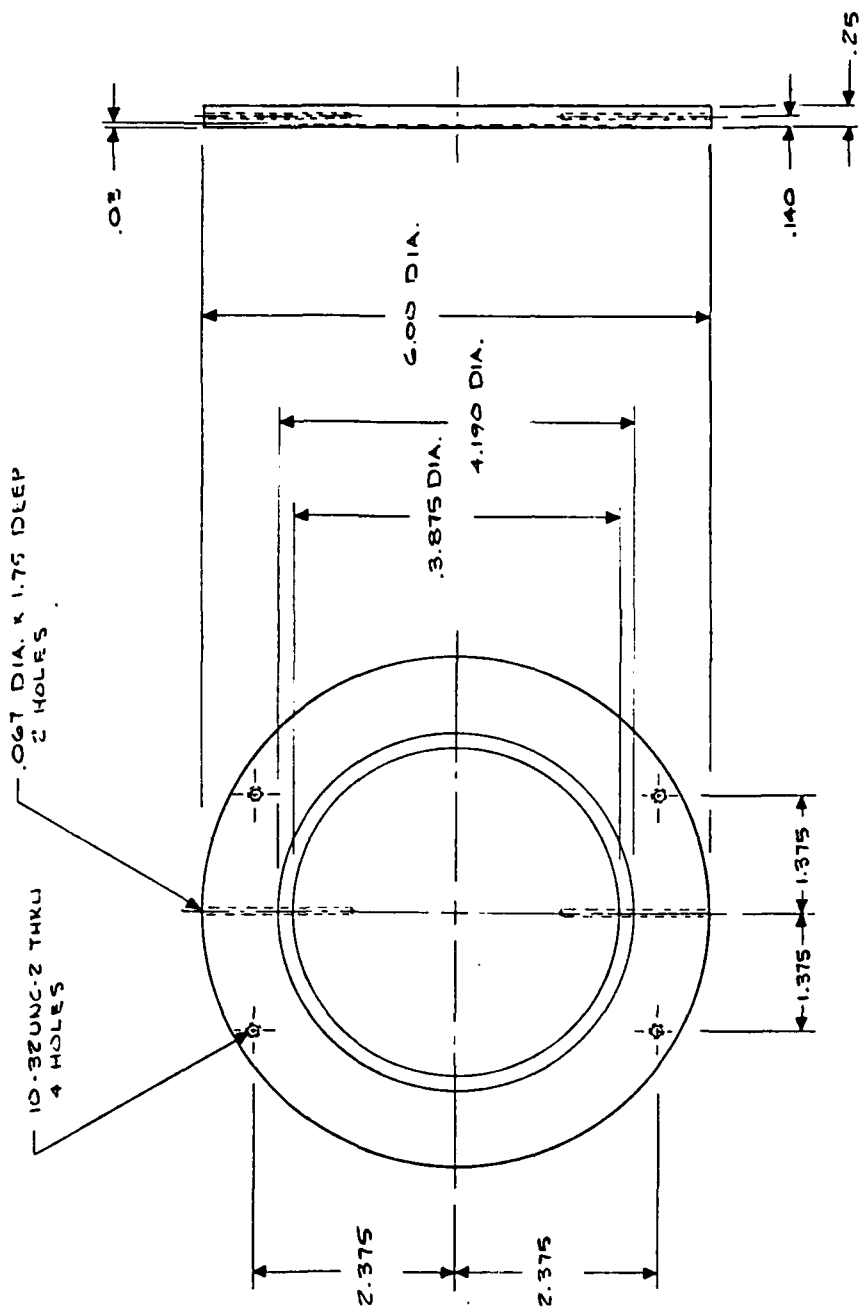

FIGURE 2-4. BOTTOM PLATE

NOTES:

△. SIZE FOR SLIDE FIT WITH DWG. 20584.

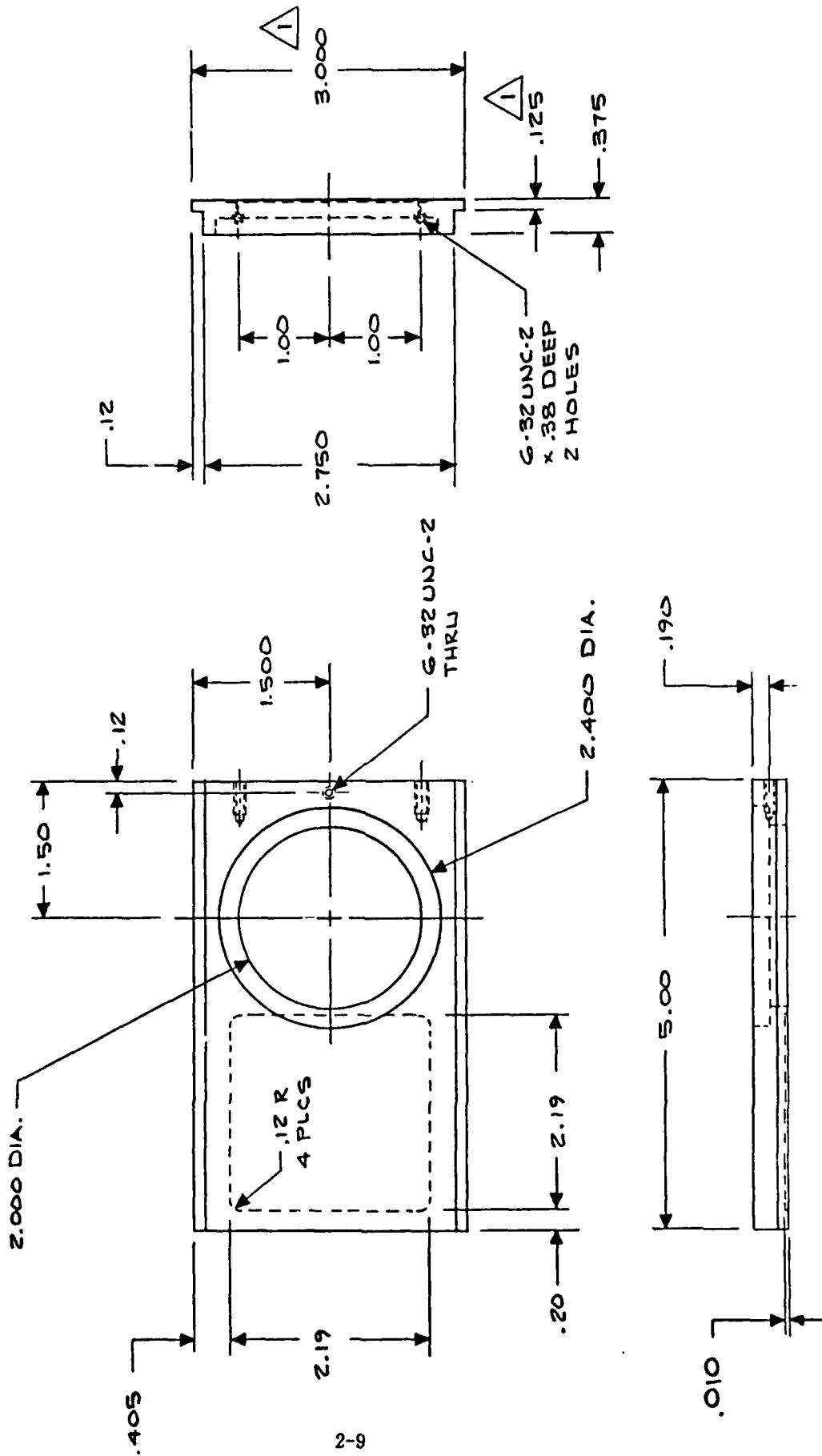

FIGURE 2-6. TOP SLIDER PLATE

TABLE 2-1
HWE CALIBRATION RUNS ON MICA

Run	Source Temp. (°C)	Substrate Temp. (°C)	Growth Time (min.)	Results
1	375	350	60	No growth
2	475	400	60	No growth
3	475	375	60	CdTe nuclei
4	475	335	80	Minimal growth
5	525	400	90	No growth
6	375	300	90	No growth

growth was evident. It appeared that the top quartz heater (substrate heater) was disrupting the temperature gradient within the growth chamber by creating a positive temperature gradient in the region near the substrate. This meant that there would be a minima in the temperature distribution causing a temperature gradient reversal in the region between the source and substrate as shown in Figure 2-7. The net effect was a "walling off" of Cd and Te₂ vapors from the substrate region and consequently little or no deposition took place, as it should have, considering the absolute magnitude of the source and substrate temperature as measured and the temperature differential ΔT calculated directly from these values.

Several options existed to correct this problem. First, the top heater could be removed entirely, and the wall heater connected to the solid state temperature controller previously used with the top heater. The control thermocouple would still be located at the substrate. Second, the top heater could be lifted to a higher position so that the temperature reversal point would be located at a position somewhere above the substrate. Third, a trial and error approach could be adopted to determine the exact power required by the top heater to reposition the reversal point above the substrate. Fourth, a shorter wall heater could be employed which would allow the thermal environment within the growth chamber to be dictated primarily by the source heater and in effect raise the reversal point above the substrate. Other options existed but required more extensive modifications to the HWE system.

The quickest path, option 1, was chosen with option 4 following in parallel. The gradient reversal problem was eliminated entirely by removing the top furnace. However, maintaining a small ΔT which might be necessary to induce low supersaturation in the vapor during growth would be difficult by choosing this option alone. Therefore, a shorter wall enclosure and wall heater were constructed but have not yet been added.

After removing the top heater, the next CdTe on mica run produced a single crystal film 1 μ m thick. This run utilized a large ΔT of 165^oC and a growth time of 90 minutes.

By changing the wattage of the wall heater smaller ΔT 's of 50^o were obtainable with source temperatures between 325 and 525^oC.

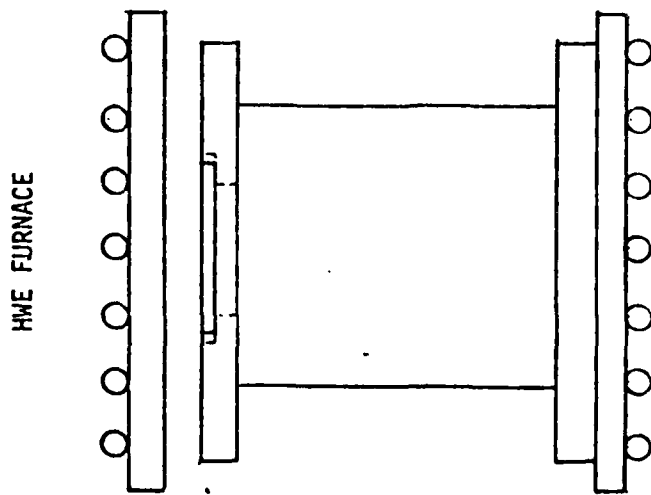
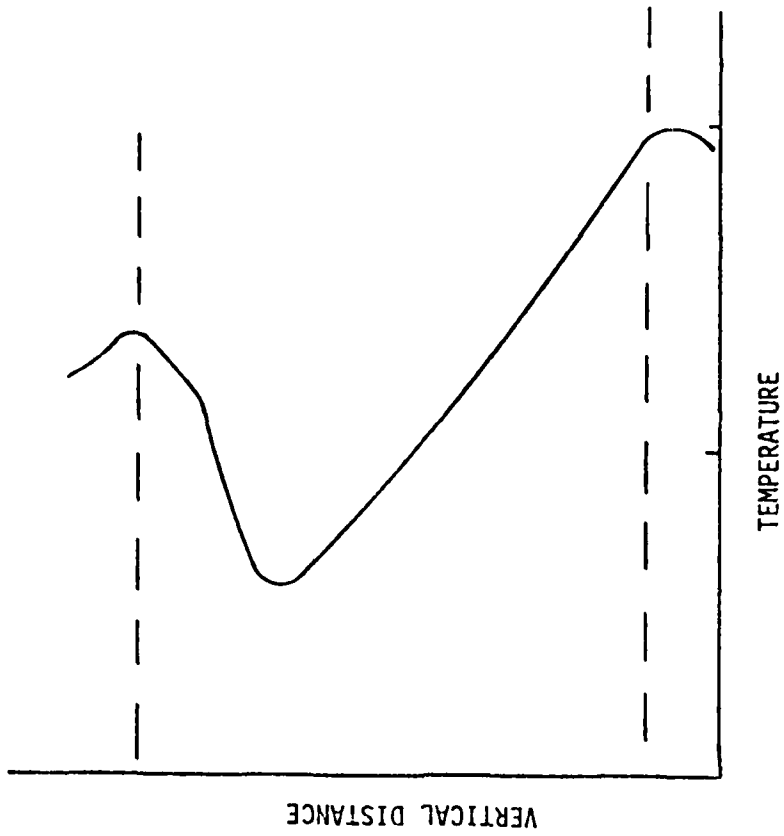

FIGURE 2-7. TEMPERATURE GRADIENT REVERSAL

2.4 DEPOSITION

A three phase plan for producing 2-inch diameter CdTe single crystal films on sapphire substrates by September was devised and enacted. The plan is designed to define an existence region for three different sapphire orientations whereby crystalline films of CdTe are obtained for certain combinations of source and substrate temperatures much the same as was done for mica earlier in this program. Phase 1 involves the deposition of CdTe films at constant source temperature (450°C) using various substrate temperatures ranging from 300°C to 450°C for the three sapphire substrate orientations chosen. After several runs at a source temperature of 450°C have been performed, they will be repeated using a source temperature of 550°C. Phase 2 will follow a similar approach but will keep constant the substrate temperature at 400 and 500°C while varying the source temperature. Phase 3 involves the growth of 2-inch diameter CdTe films on sapphire using the most promising orientation as defined by phase 1 and 2.

At the time of this report, phase 1 is partially completed having collected data points for constant source temperature of 450°C and substrate temperatures between 300 and 400°C. The three substrate orientations chosen are: the C axis (0001), the A plane (1000), and the R plane (1102). The diameter of the substrates is 1 inch. Runs have been made on all three orientations and the results tabulated in Table 2-2. While the morphology of the films grown at high supersaturation, $\Delta T > 100^\circ\text{C}$ and source temperature of 450°C is smooth and mirror-like, the films are highly polycrystalline. Average grain size for this saturation ($\Delta T > 100^\circ\text{C}$) is around 100 μm with a slight coarsening effect with orientation. Figure 2-8 shows the CdTe grain size for three different substrate orientations grown under identical conditions. It is evident that grain size coarsens as the substrate orientation approaches the C axis. That is:

$$G_{(1000)} < G_{(1102)} < G_{(0001)}$$

where G is the grain size.

The (1000) orientation (the A face) is 90° from the (0001) C axis and the R face (1102) is 45° from the C axis.

TABLE 2-2
PHASE I CdTe ON SAPPHIRE HWE RESULTS

Run	Orientation	Source Temp. (°C)	Substrate Temp. (°C)	Thickness (um)	Crystallinity	Morphology
1	(A)	450	345	1	Poly	Mirror-like
2	(C)	450	345	1.2	Poly Coarser Grain Size	Mirror-like
3	(C)	450	325	3.1	Poly	Mirror-like
4	(A)	450	325	3.0	Poly	Mirror-like
5	R	450	325	2.7	Poly	Mirror-like
6	C	450	385	1	Poly Coarser Grain Size	Dull Metallic Lustre
7	C	450	300	<1	Poly	Mirror-like

The structure also coarsens with decreasing supersaturation ΔT . Figure 2-9 shows a film grown at $\Delta T = 65^\circ\text{C}$ with the source temperature held at 450°C . Here it shows the average grain size to be greater than 20 μm for the same C orientation. Both Figure 2-8 and 2-9 are micrographs taken at 380X.

The as grown surface is mirror-like and is shown in Figure 2-10 when the saturation is high, that is, $\Delta T > 100^\circ\text{C}$ at $T_{\text{source}} = 450^\circ\text{C}$.

Growth rates for CdTe on sapphire have been determined as a function of supersaturation (ΔT) and the data collected is shown in Figure 2-11. The values of 18 and 48 μm per hour were determined at a source temperature of 450°C .

2.5 EDICT ON SAPPHIRE

2.5.1 HgCdTe Growth by Vapor Exchange and Diffusion

The vapor exchange and growth process is called the EDICT process (Evaporation and Diffusion at Constant Temperature). Similar to HWE, EDICT is an airtight, equilibrium process under isothermal conditions. It involves (1) the transfer of Hg and Te atoms from a source through a vapor space to a CdTe film; (2) reaction between the Hg and Te on the CdTe surface to form epitaxy growth; and, (3) complete homogenization of CdTe and HgTe via solid state diffusion to form the final composition which depends on the amounts of CdTe and HgTe starting materials.

In the EDICT process, a heteroepitaxial CdTe film is loaded into a sealed quartz ampoule together with a predetermined quantity of HgTe required to convert the entire film to the desired mole fraction of HgCdTe. In addition, a quantity of excess Hg is added to provide a predetermined Hg overpressure in the sealed ampoule. The EDICT process is illustrated by considering the case where the desired mole fraction for $\text{Hg}_{1-x}\text{Cd}_x\text{Te}$ is $X = .300$ and the isothermal growth temperature is chosen to be 475°C . Let us choose a quantity of excess Hg to be added to the ampoule corresponding to a vapor pressure of 0.5 atmospheres as determined by the ideal gas law. The HgTe added to the ampoule can be thought of as a source for supplying Hg atoms and Te_2 molecules to the vapor as HgTe decomposes upon heating in a closed ampoule. As the temperature in the

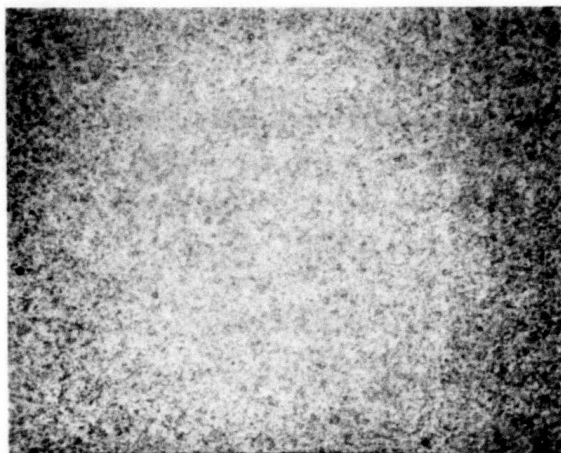

Plane Perpendicular
to C axis

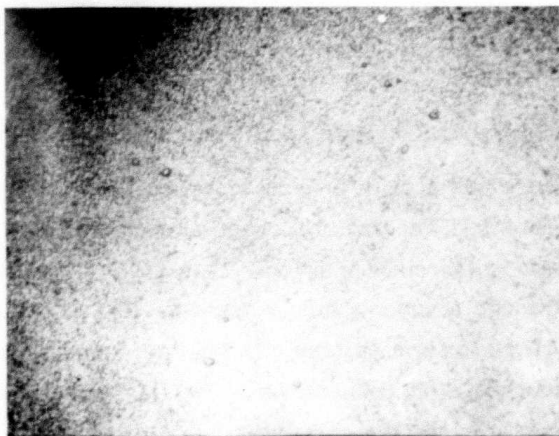

Plane at 45° to
C axis

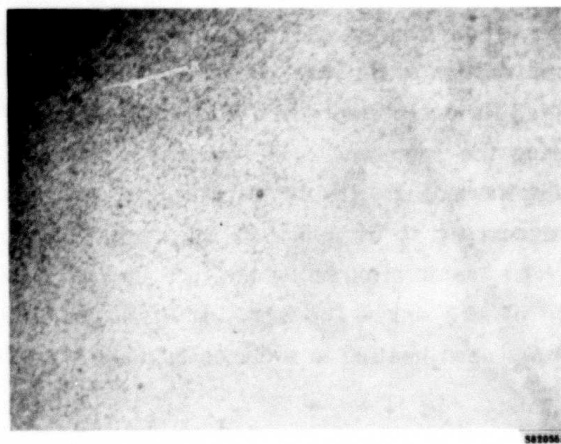

Plane parallel to
C axis

FIGURE 2-8. STRUCTURE COARSENING DUE TO ORIENTATION
(Growth parameters are: source temperature 450°C, substrate
temperature 325°C, growth time 90 minutes)

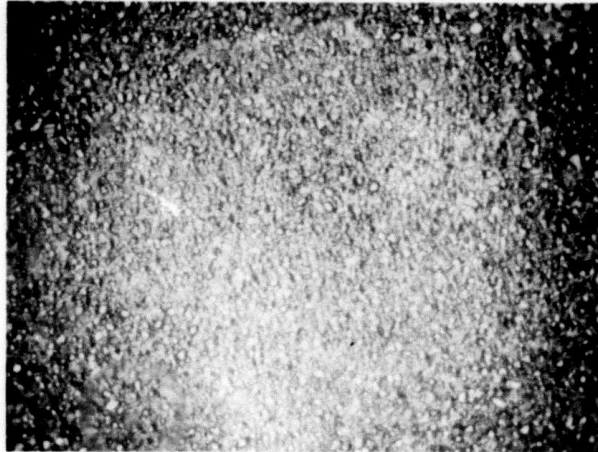
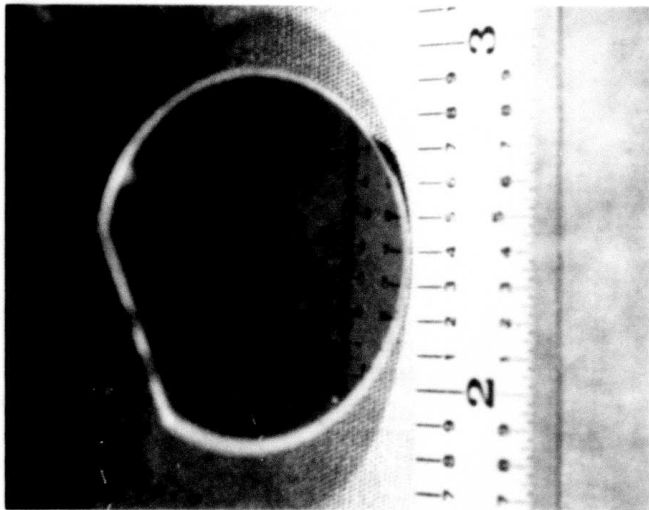
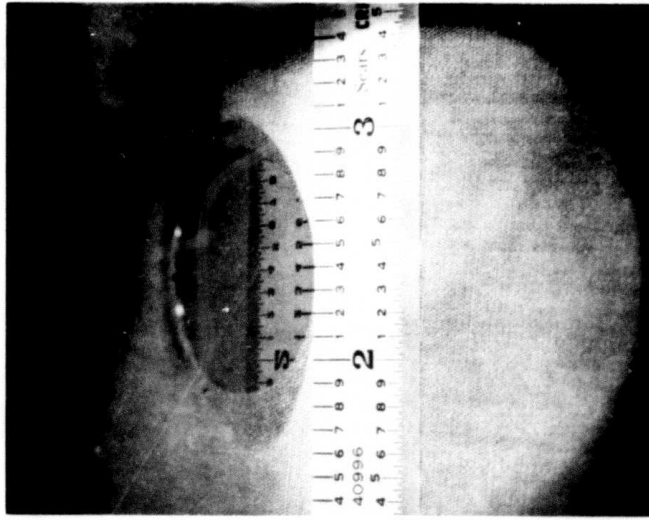

FIGURE 2-9. COARSE TEXTURE OF CdTe ON SAPPHIRE GROWN AT $\Delta T = 65^{\circ}\text{C}$
(Magnification 380X)



(a)



(b)

FIGURE 2-10. CdTe FILMS DEPOSITED ON SAPPHIRE BY HWE
(Figure (a) run 1, Figure (b) run 3 in Table 2-2)

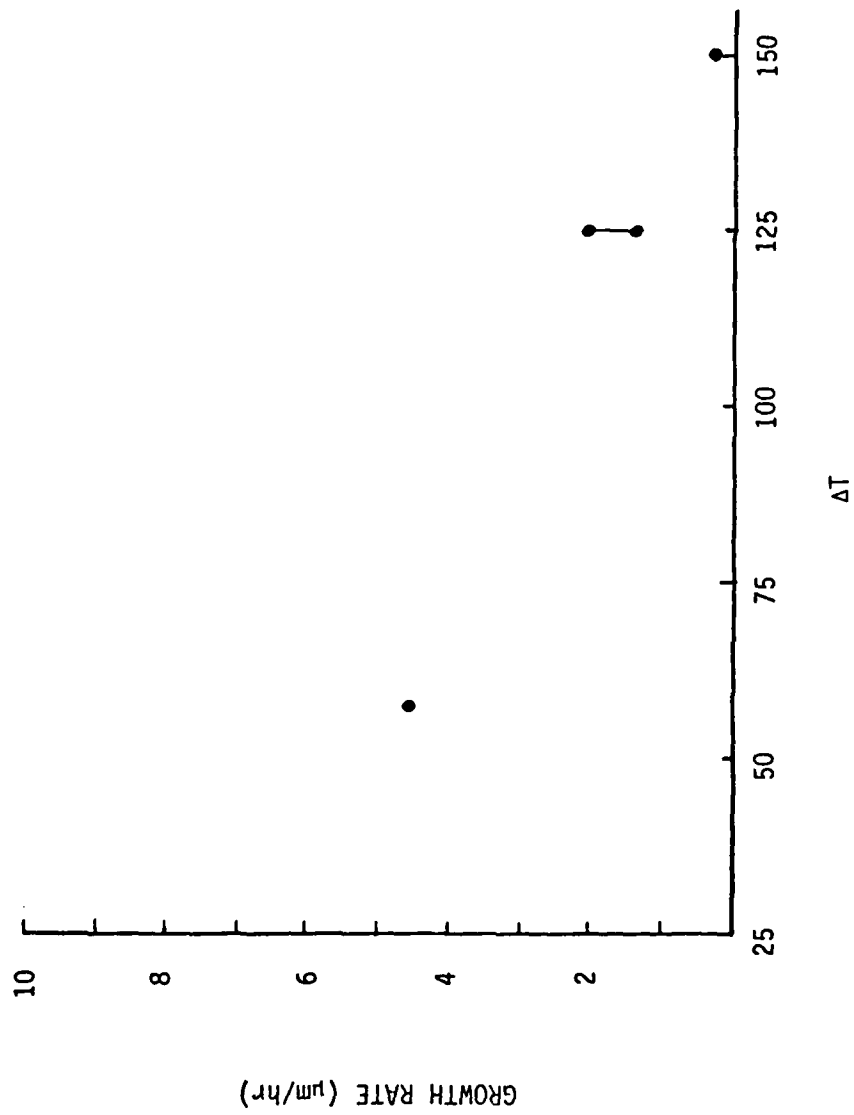

FIGURE 2-11. GROWTH RATE VS. ΔT at $T_{SOURCE} = 450^{\circ}\text{C}$

EDICT furnace increases above room temperature, the HgTe begins to decompose. At the final temperature of 475°C the equilibrium vapor pressure of Hg over HgTe is greater than 2 atmospheres; however, due to the finite HgTe source, this pressure cannot be attained even when all the Hg is vaporized. Hence, the vaporation of Hg from the HgTe source leaves the source Te rich. The Hg vapor bombards the CdTe film creating an absorbed layer of Hg atoms on the surface which cannot react because of stoichiometry. Essentially, there is a net exchange of Hg atoms from the HgTe source and excess Hg to the surface of the CdTe film at constant temperature. Because the HgTe source is now Te rich, the partial pressure of Te_2 over HgTe is significantly greater than the partial pressure of Te over either CdTe or $\text{Hg}_{.700}\text{Cd}_{.300}\text{Te}$ and there is a net transfer of Te_2 molecules to the Hg coated CdTe surface. These Te_2 molecules immediately react with two Hg atoms and form a chemical bond with the CdTe molecules at the surface. Hg atoms again coat the surface and the process repeats itself until the supply of Te_2 molecules from the HgTe source is exhausted. Solid state diffusion further homogenizes any composition variation in the HgCdTe film and anneals out any structural defects existing in the starting CdTe film.

2.5.2 Conversion of CdTe to HgCdTe on Sapphire Substrates

At the present time, only one CdTe film has been converted to HgCdTe via the EDICT process. We are awaiting the set up of a new high vacuum ionization pump for the EDICT loading station.

The one film that was converted utilized a seal off vacuum of 1×10^{-3} torr. This film was initially a 2 μm thick polycrystalline CdTe deposit on (1102) sapphire. The desired x value was .200. The actual composition as determined from IR transmission is $x = .258$. The transmission scan is shown in Figure 2-12 together with a reference curve for sapphire. The "double cutoff" curve for the HgCdTe sample is a combination of absorption from the HgCdTe which has a 300°K 50% cutoff at 5.2 μm and the sapphire substrate which cuts off at 6.6 μm .

2.6 CHARACTERIZATION OF FILMS

The quality and orientation of the sapphire substrates and films were determined using back reflection Laue x-ray diffraction. The pattern from the HgCdTe film on sapphire after EDICT conversion (Section 2.5.2) is shown in Figure 2-13. When the grain

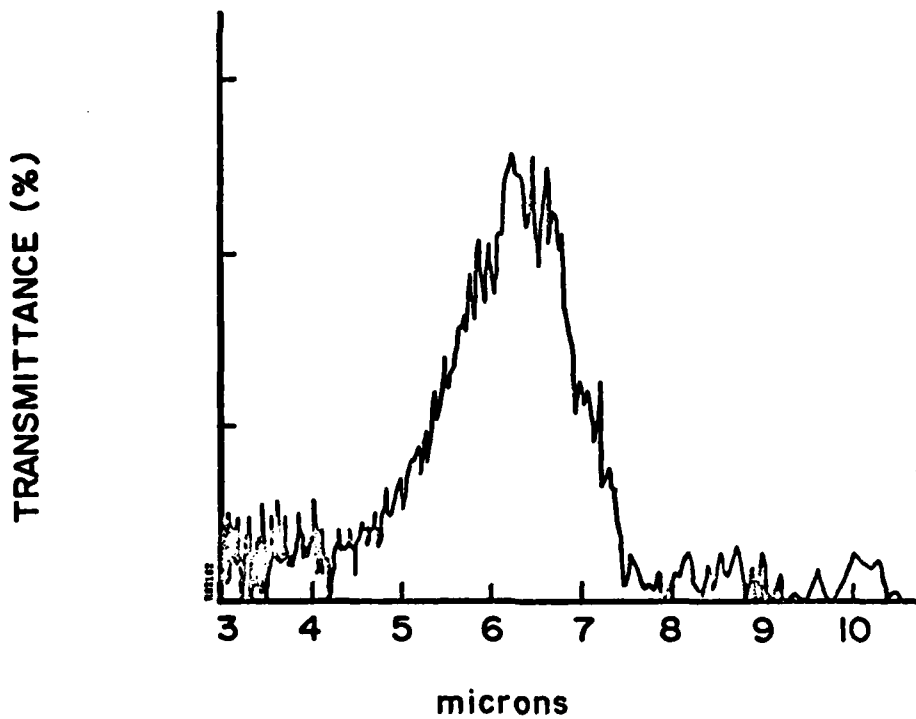
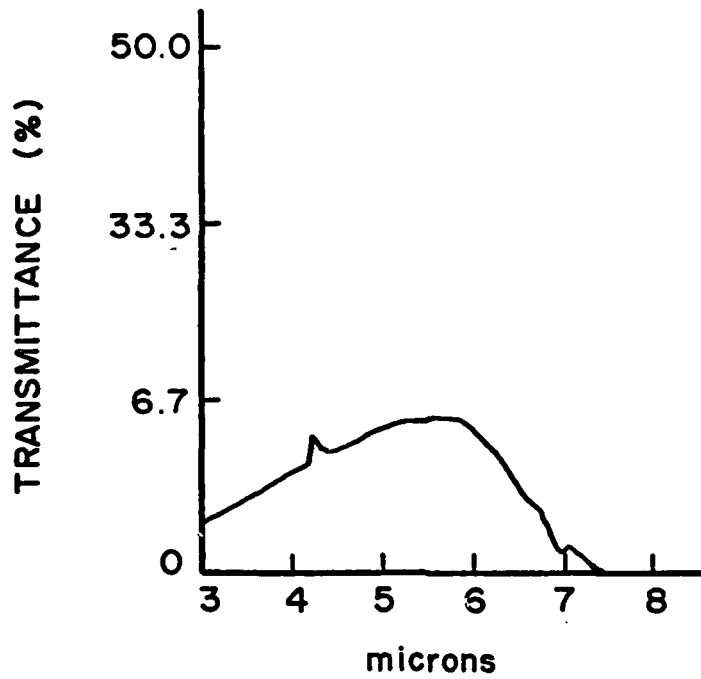

FIGURE 2-12. TRANSMISSION CURVES FOR SAPPHIRE (TOP) AND HgCdTe ON SAPPHIRE (BELOW)

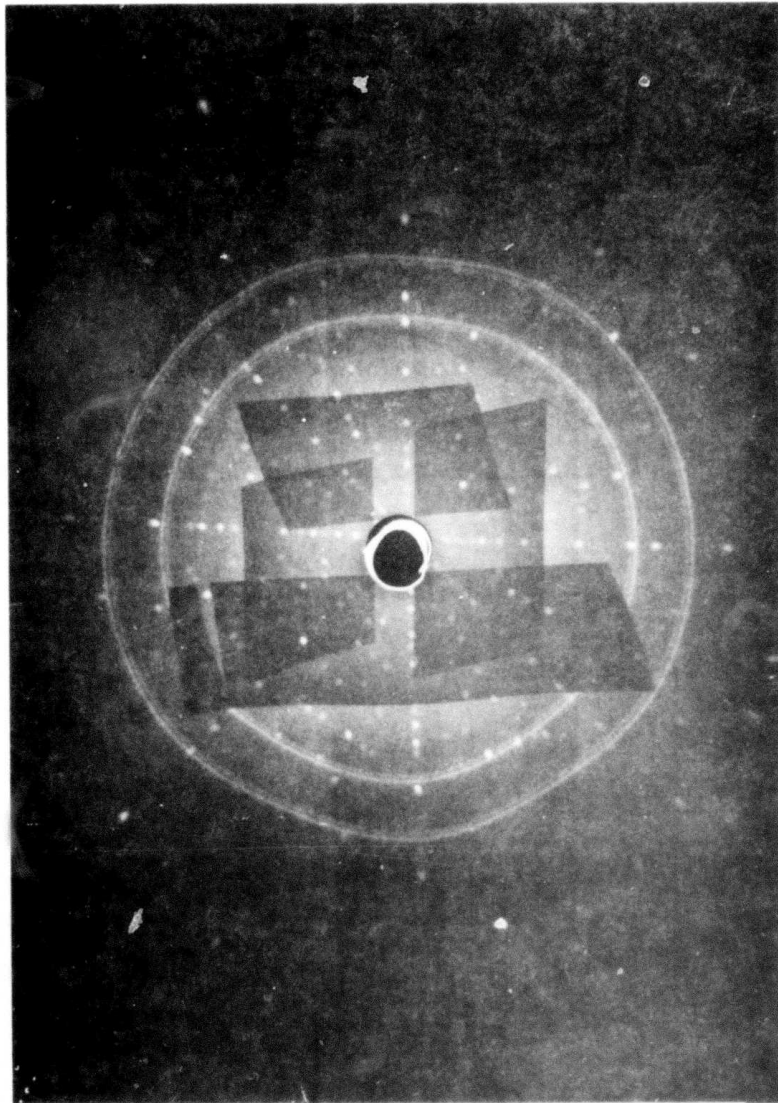

FIGURE 2-13. BACK REFLECTION LAUE X-RAY DIFFRACTION PATTERN FROM HgCdTe FILM (POLYCRYSTALLINE) ON SAPPHIRE (SINGLE CRYSTAL) SUBSTRATE

size is small the sample diffracts x-rays much the same as a powdered crystal specimen. The resulting ring structure is clearly evident in Figure 2-13, superimposed on the pattern created by the single crystal sapphire substrate. Similar patterns have been obtained for all of the CdTe films on sapphire.

The morphology of the CdTe and HgCdTe samples on sapphire substrates were compared using a high power Olympus Microscope at 380X with a Polaroid camera attachment as well as visible analysis. Results to date indicate a mirror-like surface morphology is obtainable in films grown at high supersaturations and low absolute temperatures. The resulting films are relatively thin, one to three microns, and are highly polycrystalline. Representative films are shown in Figure 2-10.

Increasing the absolute temperature and/or decreasing the supersaturation yields films with a duller luster than those previously discussed but having larger crystallite size as shown in Figure 2-14. The absolute deposition temperature for this film was 525°C and the saturation ΔT was greater than 100°C. The most recent film grown showed a metallic luster with some areas displaying mirror-like surfaces. These mirror surfaces appeared under high magnification as large (~500 um) single crystal regions imbedded in a polycrystalline matrix.

The single crystal regions appear to be recrystallizing and consuming the smaller crystallites during deposition and cool down. They also appear to have a different orientation than the matrix; however, complete characterization is not available at this time. Figure 2-15 shows the single crystal region imbedded in the polycrystalline matrix. The film was grown on (0001) sapphire at 500°C with a saturation less than 100°C.

2.7 SUBSTRATE PREPARATION

Single crystal sapphire substrates were purchased from Crystal Systems, Inc. in the form of pre-polished 1-inch diameter wafers .040-inch thick and in a single crystal 1-inch diameter boule. The pre-polished wafers were oriented, cut and polished by the supplier to a standard 60-40 finish along the (1000) plane (the polished face is perpendicular to the C axis). The orientation is $\pm 2^\circ$. The single crystal boule was sent out to Philips Laboratories, Briarcliff, NY for orienting, cutting and polishing.

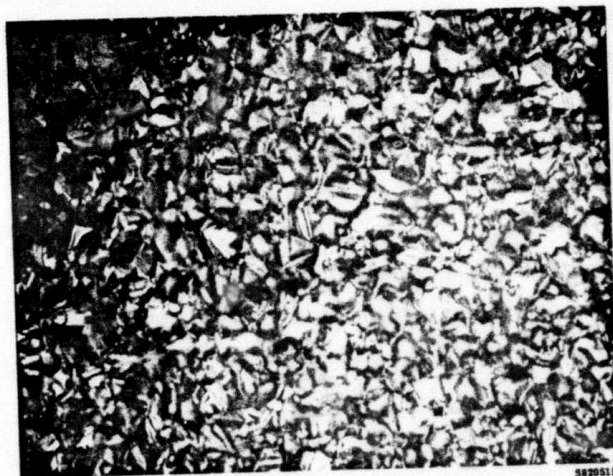

100 μm

FIGURE 2-14. MORPHOLOGY AND CRYSTALLITE SIZE OF CdTe ON SAPPHIRE GROWN AT HIGHER SOURCE TEMPERATURE ($T_{\text{source}} = 525^{\circ}\text{C}$, $\Delta T > 100^{\circ}\text{C}$)

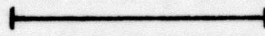
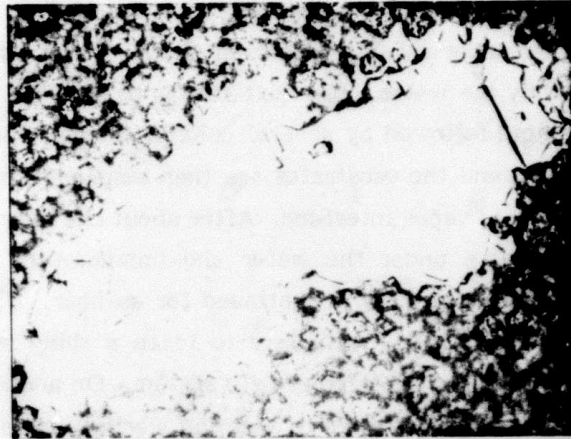

500 μm

FIGURE 2-15. SINGLE CRYSTAL CdTe EMBEDDED IN POLYCRYSTALLINE MATRIX

The boule was cut in two orientations, the (0001) face (polished face perpendicular to the C axis) and the (1102) face (polished face 45° from the C axis) to less than 1° . The wafers were cut using a gang reciprocating saw and polished using fine diamond grit. Several of the (0001) cuts were chemically polished using Syton polish.

Before the substrates are inserted in the growth chamber they are chemically degreased, etched, and finally cleansed in a propanol vapor system. The actual cleansing cycle involves degreasing the substrates using hot trichlorethylene followed by light abrasion with talcum powder under running deionized water. The substrates at this point do not appear to be wetted by the water. The next step is to etch the sapphire for thirty minutes in hot phosphoric acid followed by several deionized water rinses. The traces of water are removed by solvent and the substrates are then suspended in a large beaker of boiling propanol above the liquid vapor interface. After about one hour, equilibrium exists and the alcohol vapors condense under the wafer and immediately fall back into the reservoir in a cyclic fashion. This process is continued for an hour. Upon removal of the wafer the propanol vapors evaporate immediately to leave a shiny stain-free substrate which is then placed immediately in the HWE growth system. On occasion, the substrates were placed in a breaker of deionized water to test the wetting characteristics. At this point it was noticed that the water wet the substrate and did not bead as it had earlier in the cleansing process. All sapphire substrates to date used for CdTe heteroepitaxy have been cleaned in this manner.

2.8 CdTe SOURCE ANALYSIS

The CdTe material used as a source for the HWE deposition is a polycrystalline charge prepared from a Te solution. Several purification passes were made on the charge using a Te rich molten zone to transport undesirable impurities to one end of the ingot. Pieces from the charge were broken off and sent out for chemical analyses using Spark Source Mass Spectroscopy (SSMS). This technique is capable of resolving impurities at the .01 parts per million range over a broad range of elements. This corresponds to a detectable impurity level in CdTe of around 1.5×10^{14} atoms cm^{-3} . Table 2-3 gives the results of the SSMS analysis. The high levels of Ca and Mg are thought to be caused

TABLE 2-3
SPARK SOURCE MASS SPECTROSCOPY RESULTS ON CdTe SOURCE

Element	Concentration (ppma)
B	0.01
Mg	0.03
Cl	0.03
Ca	0.10
Cr	0.01
Mn	Interference
Fe	Interference
Cu	Interference
Cd	Major
Te	Major

by post growth handling of the material while the Cr and B concentrations are not. At present, the supplier of the polycrystalline CdTe source is preparing another CdTe ingot and will give this charge additional purification passes to reduce the Cr and B concentrations. Meanwhile, another shipment of high purity CdTe has been received from another supplier and it too has been sent out for analysis. The results have not been received at the time of this writing.

SECTION 3
REPORT OF MAIN CONTRACTOR, SPIRE CORPORATION

3.1 PULSED ELECTRON BEAM PROCESSING (PEB) OF HETEROEPI TAXIAL FILMS

The twofold objective of this task is to smooth the surface of the as-deposited films and to reduce defects by melting a thin surficial layer with a pulsed electron beam (PEB). Initial results were promising.⁽¹⁾ The technique can be applied to either CdTe or HgCdTe films.

3.1.1 CdTe Films

During the period covered by this report, NERC furnished Spire with 5 CdTe films deposited on mica substrates. Two films were not stoichiometric and were used for calibration purposes. The other three films were 5 to 10 um thick and approximately 1-inch in diameter. Previous results were duplicated. This time, however, the entire surface of the sample was processed by a single pulse. (Previous sample area was a square approximately 5mm on a side.)

The best sample was returned to NERC for conversion to HgCdTe by EDICT.

3.1.2 HgCdTe Films

Two films of HgCdTe on mica substrates were furnished by NERC to Spire. The films were processed as before by a PEB. The surface was melted but not smooth. EDS analysis showed that the samples, as-received, were not stoichiometric. There was an excess of Hg which probably accounted for the voids seen on the surface after melting a thin (less than 1 micron) layer. New samples were received for further tests.

3.2 PEB PROCESSING OF AMORPHOUS/POLYCRYSTALLINE FILMS

3.2.1 Objective

The objective of this task is to demonstrate PEB liquid phase heteroepitaxy of (1) CdTe films on foreign substrates, and (2) HgTe on a CdTe crystal. Two samples of polycrystalline CdTe on sapphire substrates, 2 um and 7 um thick, have been received and will be processed next month. The work with HgTe requires the new apparatus described below.

3.2.2 Apparatus

A schematic diagram of this apparatus is shown in Figure 3-1. It was fabricated during the time period covered by this report and calibration of the pulsed electron beam fluence at the same position has been completed. Processing awaits only the thermal calibration of the Te evaporation furnace.

The apparatus can be used in two ways. First, a CdTe crystal can be mounted to the liquid nitrogen cold finger and cooled down. Then Hg and Te are evaporated in alternating thin layers onto the surface. Pulsed melting of these films should result in liquid phase epitaxy.

The second use of this apparatus is for cleaning substrates for the HWE experiments (Section 2.6). Cleaning of wafers by pulsed laser beams in vacuum systems has been demonstrated.⁽²⁾ Epitaxial deposition requires ultra-clean surfaces; however, the HWE apparatus developed does not have the capability to clean the substrate surface in-situ. If a substrate were mounted in the apparatus shown in Figure 3-1 (at room temperature) and pulsed, the surface could be cleaned of contaminants. The surface could then be coated in vacuum with Te. If this coated substrate were placed in the HWE furnace (Section 2.2), the Te coating could be evaporated and a more effective cleaning might be achieved. Tests will be conducted if HWE of CdTe on sapphire does not yield single-crystal films soon.

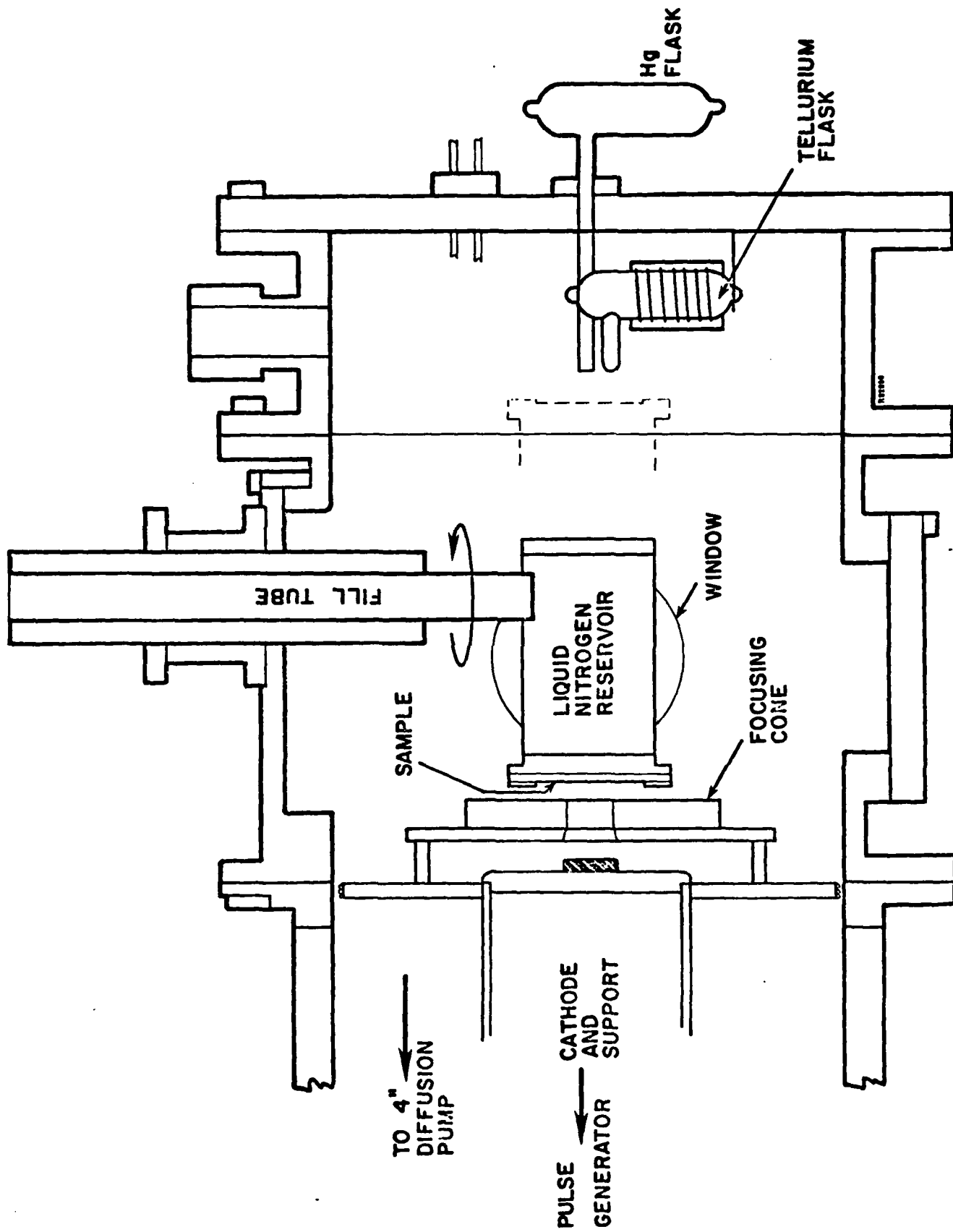

FIGURE 3-1. APPARATUS FOR CO-EVAPORATION OF Hg and Te AND PULSED PROCESS IN SITU

REFERENCES

1. S.P. Tobin, A.C. Greenwald, R.G. Wolfson, and T.T. Wong in Laser and Electron Beam Interactions with Solids, ed. B.R. Appleton and G.K. Cellar, Materials Research Society Symposia Proceedings, Vol. 4, (North-Holland 1982) p. 725.
2. J.F.M. Westendorp, Z.L. Wang, and F.W. Saris, *ibid*, p. 255.