

12

AD A118672

AD

AD-E400 888

TECHNICAL REPORT ARLCD-TR-82006

SMALL CALIBER WEAPON ROUNDS COUNTER SYSTEM

**ELSPETH HUSS
MICHAEL POTORTI**

JULY 1982



**US ARMY ARMAMENT RESEARCH AND DEVELOPMENT COMMAND
LARGE CALIBER
WEAPON SYSTEMS LABORATORY
DOVER, NEW JERSEY**

APPROVED FOR PUBLIC RELEASE; DISTRIBUTION UNLIMITED.

DTIC FILE COPY

**DTIC
ELECTE
AUG 26 1982**

B

82 08 12 00 8

UNCLASSIFIED

SECURITY CLASSIFICATION OF THIS PAGE (When Data Entered)

REPORT DOCUMENTATION PAGE		READ INSTRUCTIONS BEFORE COMPLETING FORM
1. REPORT NUMBER Technical Report ARLCD-TR-82006	2. GOVT ACCESSION NO. DA-2148-672	3. RECIPIENT'S CATALOG NUMBER
4. TITLE (and Subtitle) SMALL CALIBER WEAPON ROUNDS COUNTER SYSTEM		5. TYPE OF REPORT & PERIOD COVERED Final Sep 1978 - Sep 1981
		6. PERFORMING ORG. REPORT NUMBER
7. AUTHOR(s) Elspeth Huss Michael Potorti		8. CONTRACT OR GRANT NUMBER(s)
9. PERFORMING ORGANIZATION NAME AND ADDRESS ARRADCOM, LCWSL Nuclear and Fuze Div (DRDAR-LCN-C) Dover, NJ 07801		10. PROGRAM ELEMENT, PROJECT, TASK AREA & WORK UNIT NUMBERS
11. CONTROLLING OFFICE NAME AND ADDRESS ARRADCOM, TSD STINFO Div (DRDAR-TSS) Dover, NJ 07801		12. REPORT DATE July 1982
		13. NUMBER OF PAGES 37
14. MONITORING AGENCY NAME & ADDRESS (if different from Controlling Office) ARRADCOM, FC&SCWSL Special Projects Group (DRDAR-SPG) Dover, NJ 07801		15. SECURITY CLASS. (of this report) Unclassified
		15a. DECLASSIFICATION/DOWNGRADING SCHEDULE
16. DISTRIBUTION STATEMENT (of this Report) Approved for public release; distribution unlimited.		
17. DISTRIBUTION STATEMENT (of the abstract entered in Block 20, if different from Report)		
18. SUPPLEMENTARY NOTES		
19. KEY WORDS (Continue on reverse side if necessary and identify by block number) Projectile rounds sensor Electronic rounds counter Rate of fire (ROF) calculator		
20. ABSTRACT (Continue on reverse side if necessary and identify by block number) The small caliber weapons rounds counter system was designed to facilitate the testing of small caliber weapons. This system detects the projectile fired by a small caliber weapon and displays the number of rounds fired or calculates the rate of fire for the weapon.		

DD FORM 1473
1 JAN 73

EDITION OF 1 NOV 65 IS OBSOLETE

UNCLASSIFIED

SECURITY CLASSIFICATION OF THIS PAGE (When Data Entered)

CONTENTS

	Page
Introduction	1
Description	1
Rounds Counter Electronics Systems	1
Rate of Fire Capabilities	5
Rounds Counter Sensor Investigation	6
Spectra-Physics Model 155 Laser Beam with Photo-Diode Sensor	6
Kistler Models M-701 and M-601 Pressure Transducers	6
Electronic Counters, Inc. Model M-6200 Gun Microphone	7
Oehler Research Model 55 Ballistics Screen	7
Automated Concepts, Inc. Radar-Cell Mass Motion Detector	7
Sensor Test and Evaluation Results	7
Spectra-Physics Model 155 Laser Beam with Photo-Diode Detector	7
Kistler Model M-601 and M-701 Pressure Transducers	8
Electronic Counters Inc., Model M-6200 Gun Microphone	8
Oehler Research Model 55 Ballistics Screen	8
Automation Concepts Mass Motion Doppler Radar Detection System	8
Conclusions	9
Appendix	
Rounds Counter Electronics	23
Distribution	35



Accession For	
NIE	<input checked="" type="checkbox"/>
DTIC	<input type="checkbox"/>
Unannounced	<input type="checkbox"/>
Justification	
By	
Distribution/	
Availability Codes	
Dist	Avail and/or Special
A	

FIGURES

	Page
1 Functional block diagram of rounds counter system	2
2 Rounds counter electronics block diagram	3
3 Timing diagram showing slowest and fastest rates of fire that will be calculated by rounds counter	11
4 Laser beam with photo-diode sensor test setup	12
5 Pressure transducer test setup	13
6 Gun microphone test setup	14
7 Ballistics screen	15
8 Laser beam with photo-diode detector testing results (M16 weapon tested)	16
9 M-6200 gun microphone testing results (M16 weapon tested)	16
10 Kistler pressure transducer testing results (M16 weapon tested)	17
11 Oehler Research Model 55 ballistics screen modification	18
12 Ballistics screen testing results (M16 weapon tested)	19
13 Radar cell mass motion detector testing results for one shot fired (M16 weapon tested)	20
14 Radar cell mass motion detection system modification	21
15 Rounds counter panel layout	22

INTRODUCTION

The rounds counter system was designed to facilitate the testing of small caliber weapons. This system has two parts: (1) a sensor to detect the firing of the test weapon, and (2) an electronic rounds counter to display the results (fig. 1).

The sensor detects the rounds fired by the weapon and provides a 12-volt positive output pulse to the input of the rounds counter. This output from the sensor is hard-wired to the rounds counter electronics with a double conductor shielded coax cable. The length of this cable should be less than 250 ft (70 m) to reduce the effects of the capacitance of the cable.

The rounds counter stores the pulses from the sensor and displays either the number of rounds fired by the weapon or calculates its rate of fire (ROF) depending on which mode of operation (rounds or rate) the user desires.

The rounds counter is powered by a 6-volt external source. The power supply requirements for the various sensors are described in the rounds counter sensor investigation section of the report.

DESCRIPTION

Rounds Counter Electronics System

Sensor

For each round fired from the weapon, the sensor outputs a 12-volt dc positive pulse 10 to 50 milliseconds in duration to the input of the rounds counter. This input is applied to the latch time, rounds counter, and end of burst detection circuitry (fig. 2).

Rounds Counter Circuitry

As the detected rounds are applied from the sensor, their counter circuitry stores and counts the pulses.

The output of the counter circuitry of the rounds is applied to the LCD display when "rounds" are selected on the panel. The number of rounds counted will be cumulative until the system is reset. When "rate" is selected on the panel, the output of the rounds counter circuitry is applied to the enable calculator circuitry to perform rate of fire calculations.

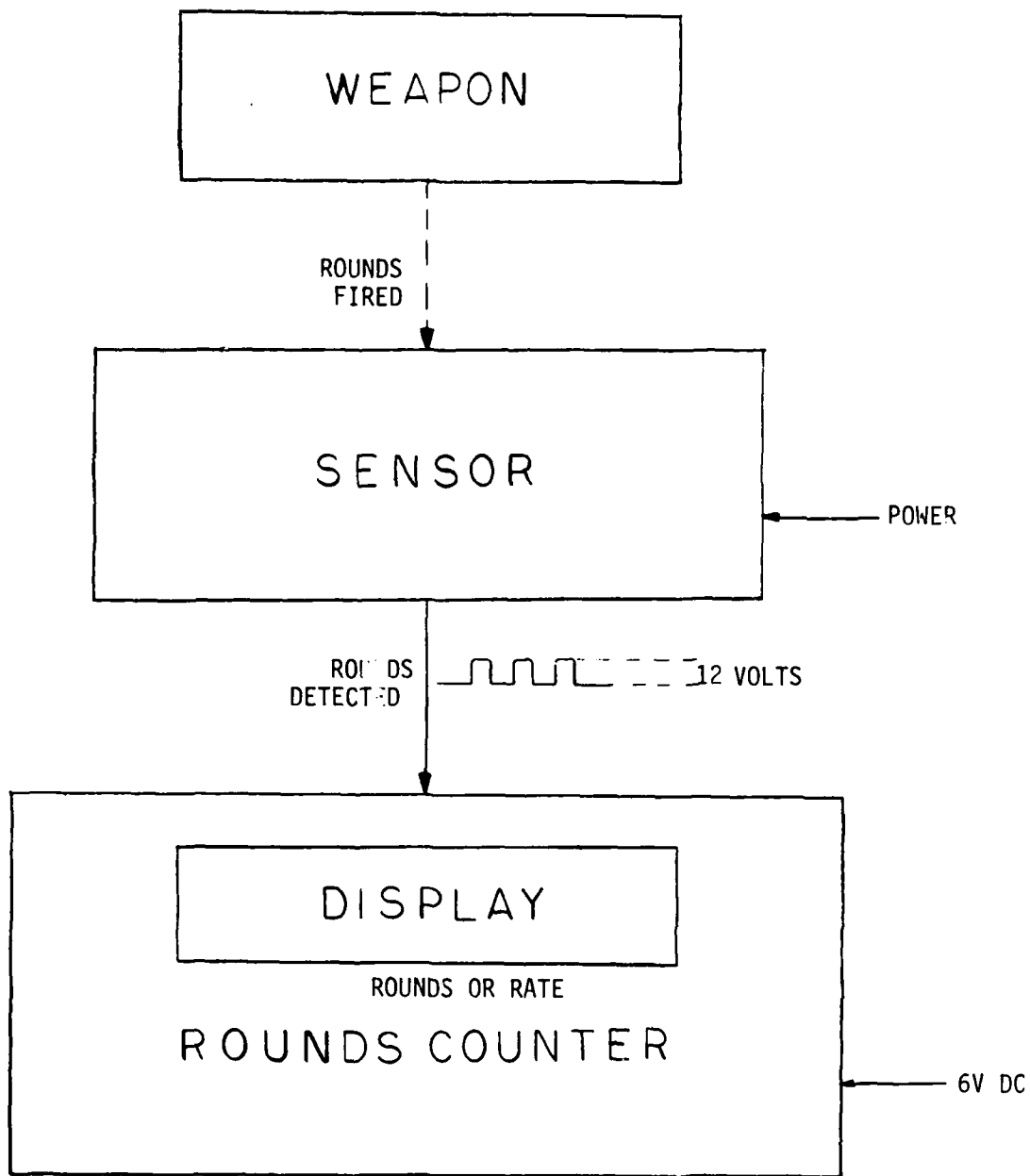

Figure 1. Functional block diagram of rounds counter system

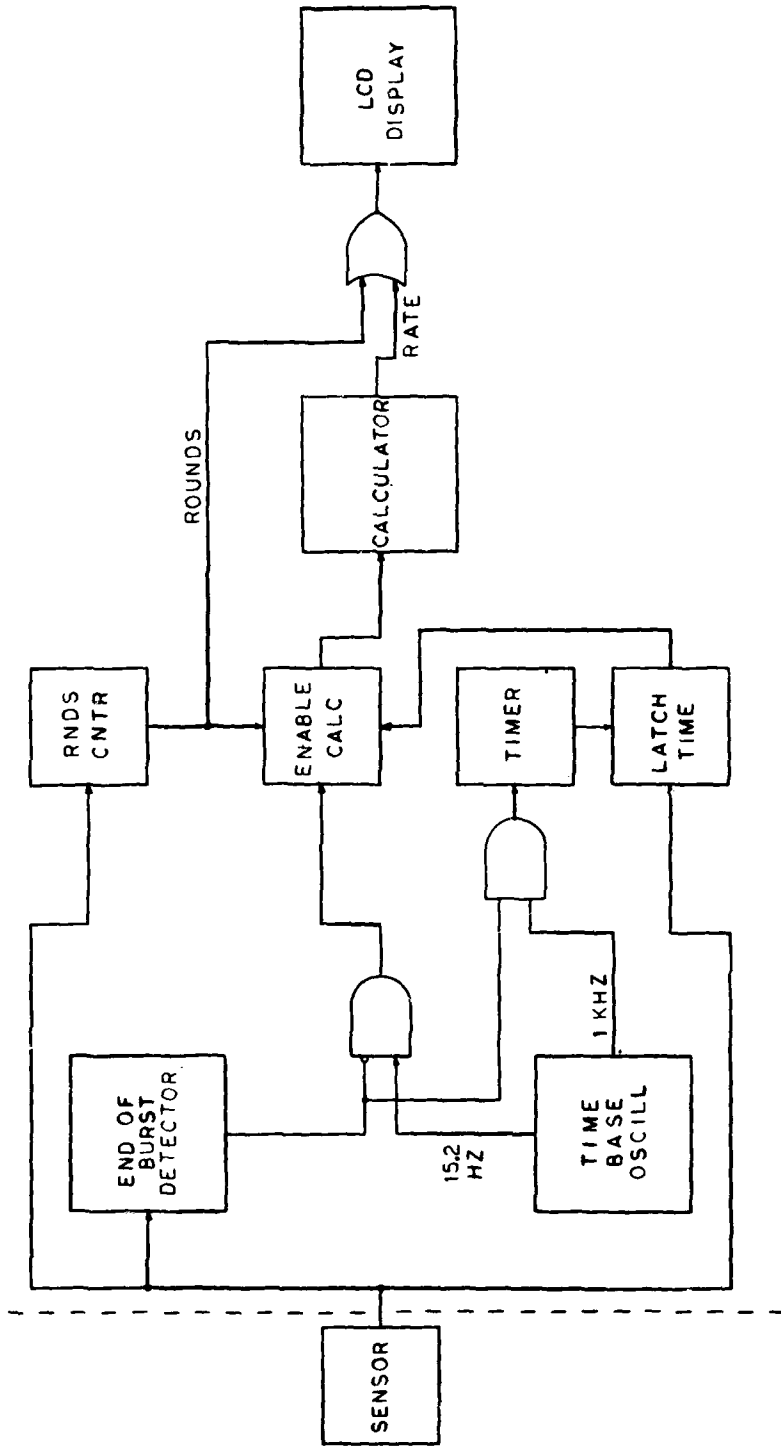

Figure 2. Rounds counter electronics block diagram

End of Burst Detector

This circuitry enables 1 kHz time pulses to be counted in the timer when the first round is fired for a burst. During the burst of fire, if 250 milliseconds elapses from one round to the next, the end of burst detection circuitry disables the 1 kHz timing pulses to perform rate of fire calculations.

Time Base Oscillator

This circuitry generates 1 kHz time pulses during burst length and 15.2 Hz clocking pulses for calculation sequencing.

Timer

The timer counts and stores the number of 1 kHz time pulses during a burst of fire.

Latch Time Circuitry

This circuitry latches in the accumulated time at the end of each round preventing time inaccuracies from occurring after the last round has been fired.

The output of the latch time circuitry is applied to the enable calculator circuitry and represents the total elapsed time for the burst of fire.

Enable Calculator Circuitry

After the burst of fire has occurred, the burst time and the number of rounds is input to the enable calculator circuitry. The 15.2 Hz clocking pulses sequence the input information to the calculator in this form:

1. Thousands, hundreds, tens, and units are sequenced to the enable calculator circuitry from the rounds counter.
2. The "minus (-)" input to the calculator is enabled.
3. A "one (1)" is input to the calculator.
4. The "equal to (=)" input to the calculator is enabled.
5. The "multiply (x)" input to the calculator chip is enabled.
6. The constant "60,000" is entered in the calculator chip.

7. The "divide by (+)" input to the calculator is enabled.
8. The overall time for the burst of fire is entered into the calculator (thousands, hundreds, tens, ones).
9. The "equal to (=)" input on the calculator chip is enabled.

Calculator

The calculator performs all the necessary computations for determining the rate of fire for the tested weapon. The rate of fire calculations performed by the calculator are derived from the rate of fire (ROF) equation.

Equation

T_t = Elapsed time (minutes)

T = Number of time pulses during burst of fire

f = Frequency of time pulses (1 kHz or 6×10^4 pulses/min)

N = Total number of rounds for the burst

$$T_t = \frac{T}{f} = \frac{T}{(6 \times 10^4)}$$

$$\text{Rate of fire} = \frac{(N - 1)}{T_t} = \frac{(N - 1) (6 \times 10^4)}{T}$$

LCD Display

The LCD displays either the cumulative number of rounds fired or the rate of fire for the tested weapon. (See appendix for a more detailed description of rounds counter electronics and schematic.)

Rate of Fire Capabilities

Minimum Capabilities

The minimum rate of fire that will be calculated by the rounds counter is 240 rounds per minute or four rounds per second. After 250 milliseconds, the

end of burst detection circuitry disables the 1 kHz timing pulses preventing rates of fire of 240 rounds per minute or less from being calculated (fig. 3).

Maximum Capabilities

The maximum rate of fire that will be calculated by the rounds counter is 9,999 rounds per minute. Theoretically, if the sensor could output a pulse every millisecond, the rounds counter would calculate the rate of fire. However, the limiting factor in determining the maximum rate of fire is the pulse width of the sensor's output (fig. 3).

ROUNDS COUNTER SENSOR INVESTIGATION

A variety of sensors were field tested to be interfaced with the rounds counter. The sensors were evaluated to detect the fired projectiles, the ejected cartridge casings, or the weapon's muzzle pressure.

Description of the sensors and how they will be used is briefly explained in the next few paragraphs.

Spectra-Physics Model 155 Laser Beam with Photo-Diode Sensor

This sensing device positions a laser beam in direct line with a light sensitive photo diode. A voltage output occurs at the output of the photo-diode when the laser light of the laser beam is broken. This voltage output would be used as an input to the rounds counter for triggering the counting circuitry.

The tested configuration of the laser and photo-diode in relation to the weapon is shown in figure 4.

Kistler Models M-701 and M-601 Pressure Transducers

A pressure transducer is a device that senses a change in the air pressure applied to its input. The pressure transducer would be used to detect the change in pressure at the muzzle of the weapon when the weapon is fired.

The tested optimum configuration of the pressure transducer in relation to the weapon is shown in figure 5.

Electronic Counters, Inc. Model M-6200 Gun Microphone

The gun microphone is a device that produces a voltage output when a change in pressure is detected at its input. The output of the gun microphone is a dc pulse output with a high signal to noise ratio.

The tested optimum configuration of the gun microphone in relation to the weapon is shown in figure 6.

Oehler Research Model 55 Ballistics Screen

This device uses a 60-watt Lumiline lightbulb with five light-sensitive detectors that responds to a change in light intensity when a projectile is fired between the light and the detectors. The output of the ballistics screen is a 12-volt positive pulse, 2 to 30 milliseconds (adjustable) in duration. The ballistics screen is powered by 115 volts ac.

The tested optimum configuration of the ballistics screen in relation to the weapon is shown in figure 7.

Automated Concepts, Inc. Radar-Cell Mass Motion Detector

This device is a self-contained constant wave doppler radar system. This system detects any fast movement through its 6-inch detection range. Its output is a 12-volt positive pulse, 2 to 200 milliseconds (adjustable) in duration. The radar-cell is powered by a 12-volt dc power source (battery or power supply). The mass motion detector would be used to detect the ejected casings. Testing is presently performed with the mass motion detector. An optimum configuration has not yet been determined.

SENSOR TEST AND EVALUATION RESULTS

Spectra-Physics Model 155 Laser Beam with Photo-Diode Detector

This method of detecting the projectile was unacceptable. The flash from the muzzle of the weapon greatly effected the output of the photo diode. Several bursts of voltage pulses occurred at the output of the phototransistor circuit from each round being fired (fig. 8).

Kistler Model M-601 and M-701 Pressure Transducers

The pressure transducer method of detecting muzzle pressure changes proved to be effective. The output of both pressure transducers are sharp, clean dc pulses with a high signal-to-noise ratio. The transducer output would have to be amplified, inverted, and clamped to be compatible with the rounds counter (fig. 9).

Electronic Counters Inc., Model M-6200 Gun Microphone

The gun microphone sensor produced an identifiable and accurate output which could be used to trigger the rounds counter. However, the amplitude of the output produced by the gun microphone varied from round to round, and it would be necessary to amplify and clamp the output to produce the necessary 12-volt dc input required to trigger the rounds counter (fig. 10).

Oehler Research Model 55 Ballistics Screen

The ballistics screen sensor produced an excellent output for detecting the fired projectile. The output was a sharp noiseless digital pulse that easily triggered the rounds counter (fig. 11).

The following two modifications were made to the ballistics screen:

1. The length of the ballistics screen was cut down in size to accommodate the metal framed window at the firing range. This modification also made the ballistics screen more sensitive to the projectile as the light source was brought closer to the detectors.

2. A 0.47-microfarad capacitor (fig. 12) in the ballistics screen latching output circuitry was changed to 1.5 microfarads so that the output could be latched at least 20 milliseconds. This improvement was needed because it was noted that some conductive particles were leaving the rifle barrel slightly later than the projectile and were being counted as additional rounds.

Automation Concepts Mass Motion Doppler Radar Detection System

The mass motion detector is an effective means of detecting ejected casings during weapon firing tests. The output is a sharp noiseless digital pulse. To make the mass motion detector compatible with the rounds counter the output would have to be inverted (fig. 13).

A modification was made to the mass motion detector. A model 2N2222 NPN transistor and two resistors (1K-ohm and 5K-ohms) were added to the mass motion output of the detector to invert the negative pulse output to positive (fig. 14).

CONCLUSIONS

The rounds counter system is an effective device which should be used to monitor the rate of fire and the number of rounds fired by any small caliber weapon. It is lightweight, portable, requires a very small amount of current during operation (less than 10 ma), and is easily operated. The overall rounds counter system is 99.6% accurate under worst case conditions (ROF calculated for a two-round burst of fire). Since the rounds counter electronics are entirely solid state, the system is very reliable.

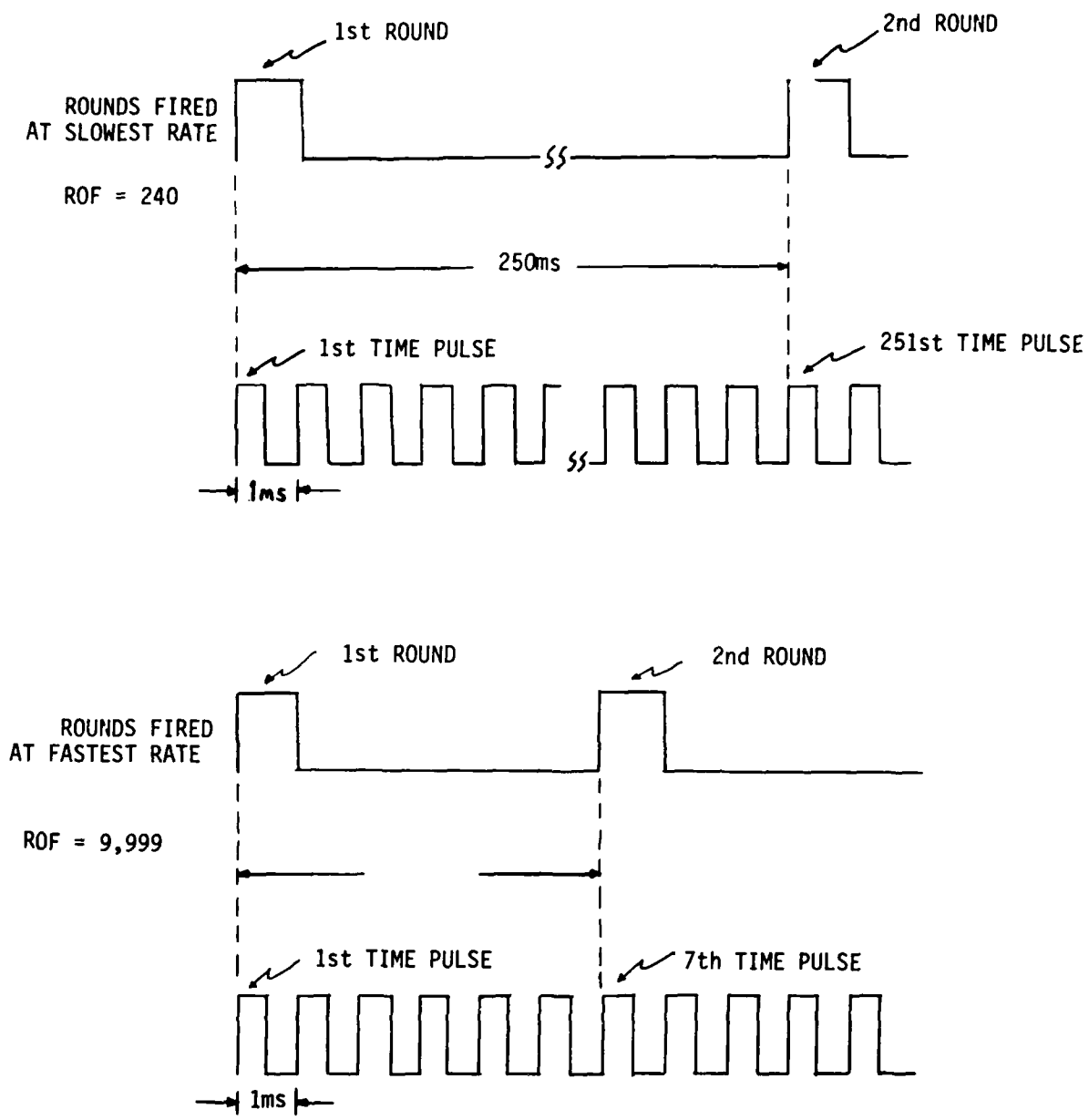

Figure 3. Timing diagram showing slowest and fastest rates of fire that will be calculated by rounds counter

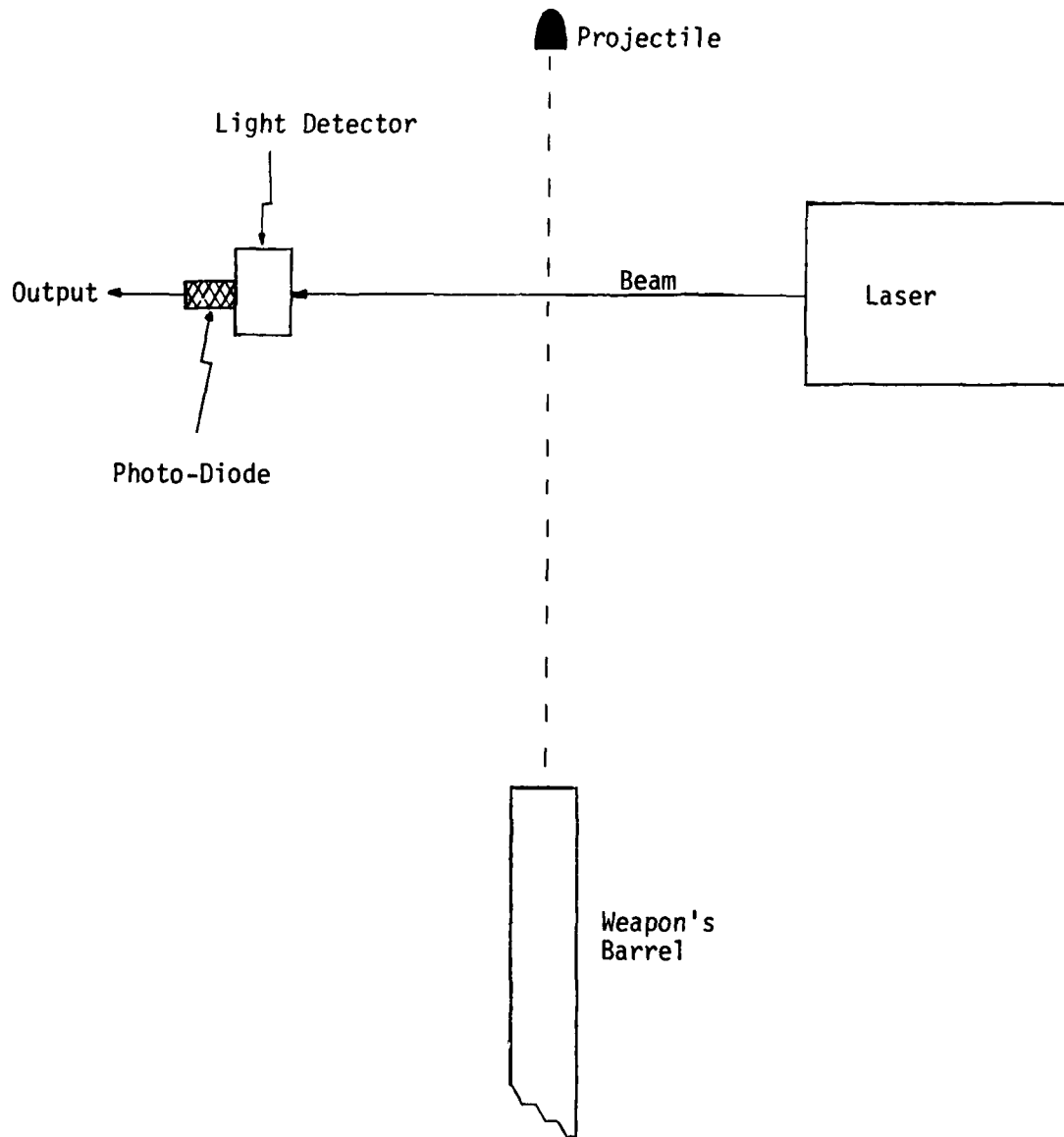

Figure 4. Laser beam with photo-diode sensor test setup

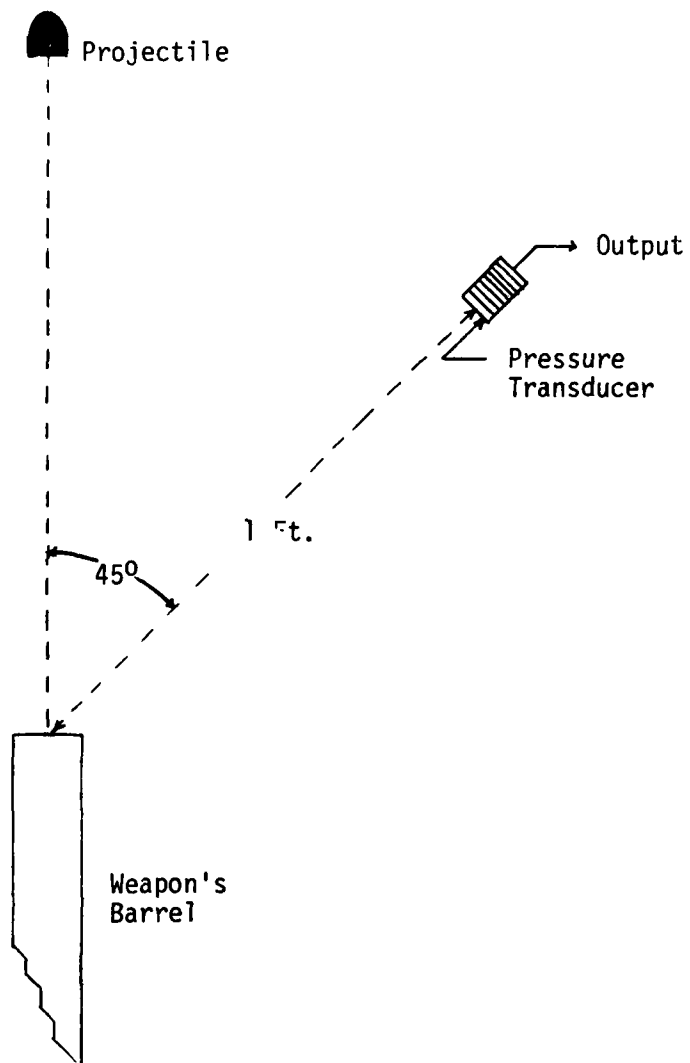

Figure 5. Pressure transducer test setup

"D" = 1 foot for M16 weapon
"D" = 3 feet for M85 weapon

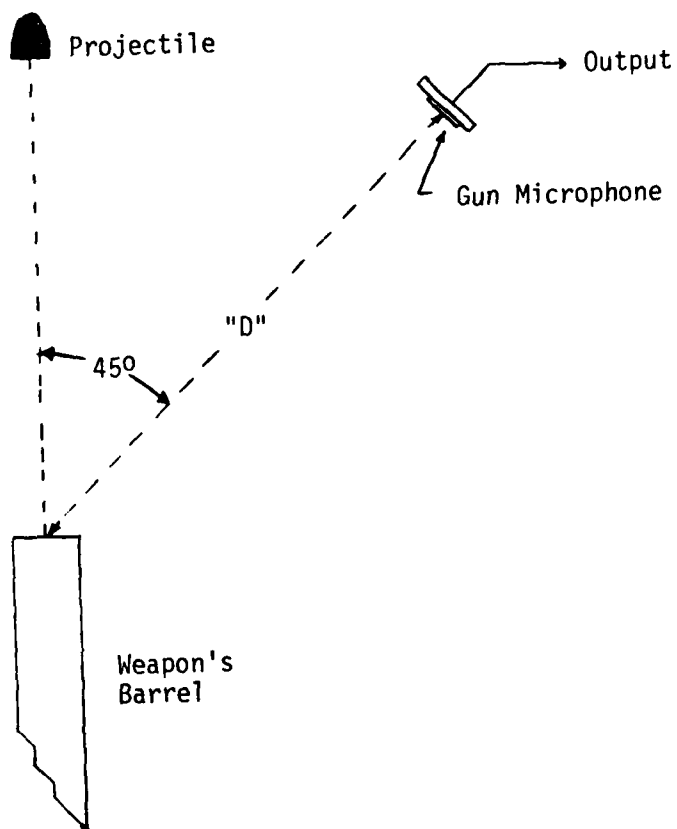

Figure 6. Gun microphone test setup

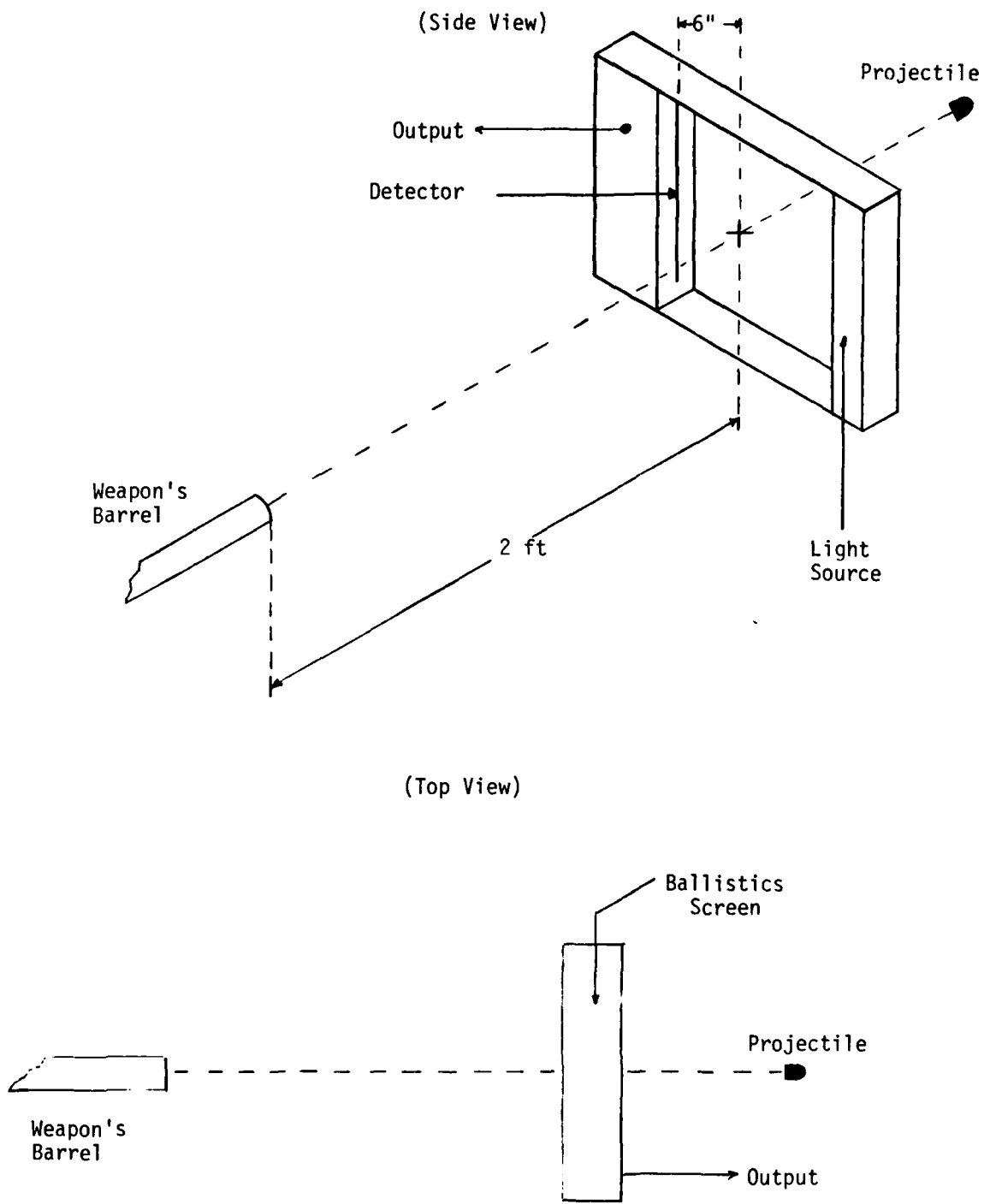
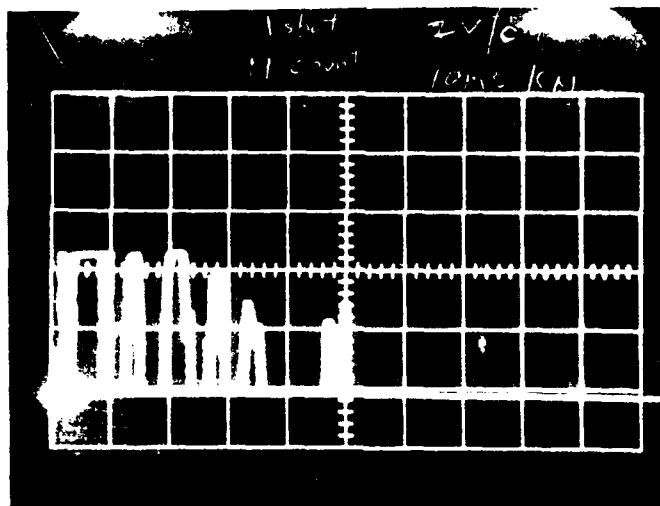
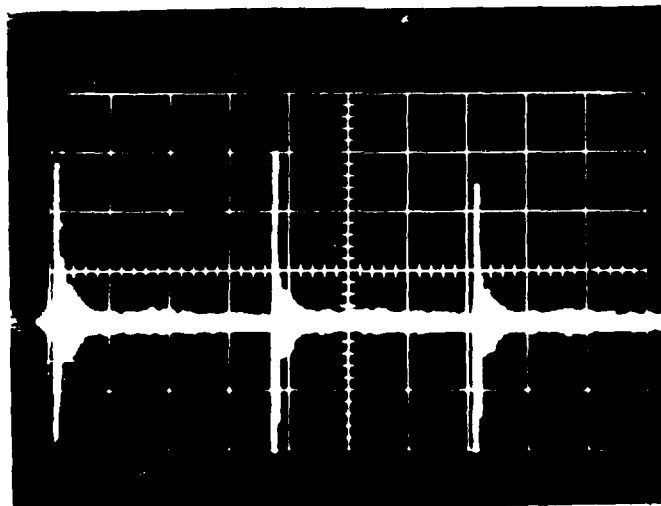

Figure 7. Ballistics screen



V = 2 V/cm
T = 10ms/cm

Figure 8. Laser beam with photo-diode detector testing results (M16 weapon tested)



V = 0.2 v/cm
T = 20ms/cm

Figure 9. M-6200 gun microphone testing results (M16 weapon tested)

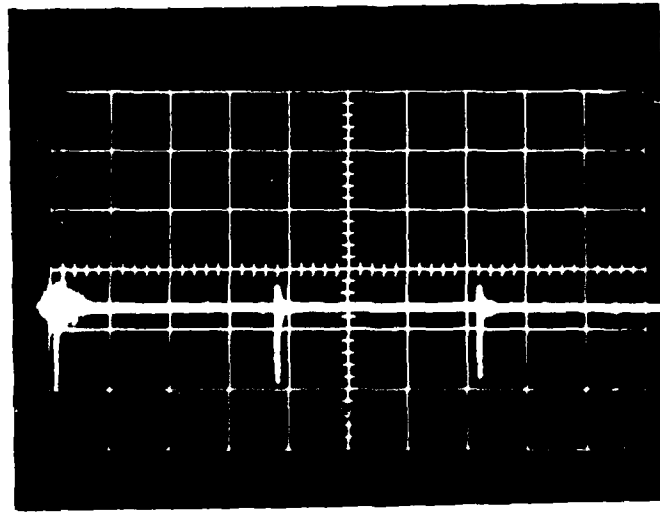

V = 0.01 V/cm
T = 20ms/cm

Model M-601

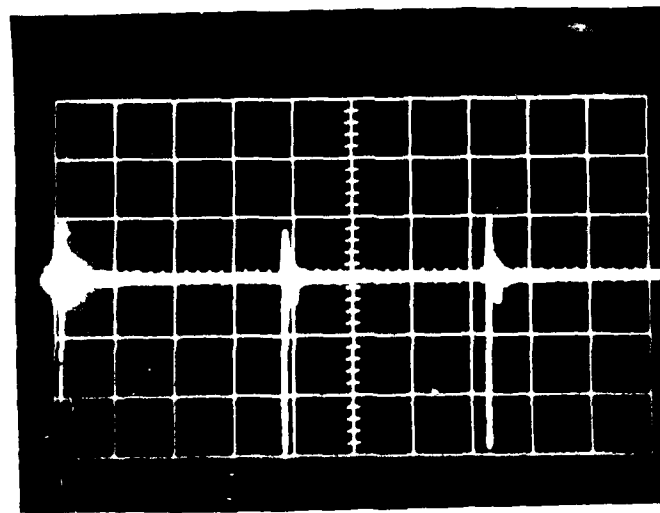

V = 0.01 V/cm
T = 20ms/cm

Model M-701

Figure 10. Kistler pressure transducer testing results (M16 weapon tested)

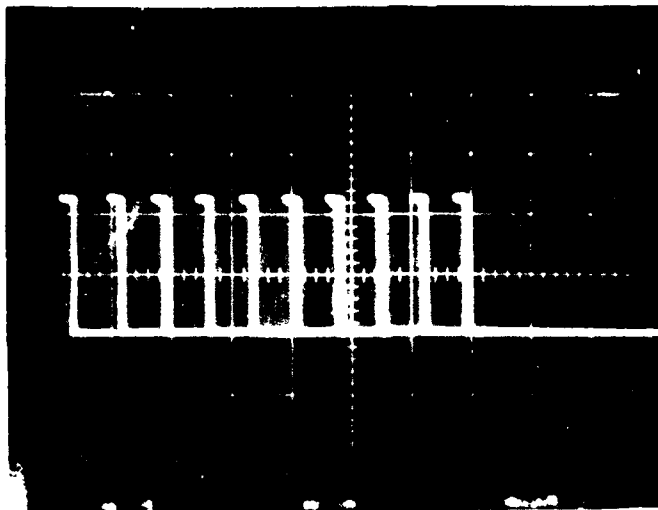

$T = 0.1 \text{ sec/cm}$
 $V = 5v/cm$

10 round burst of fire at 820 rounds/minute

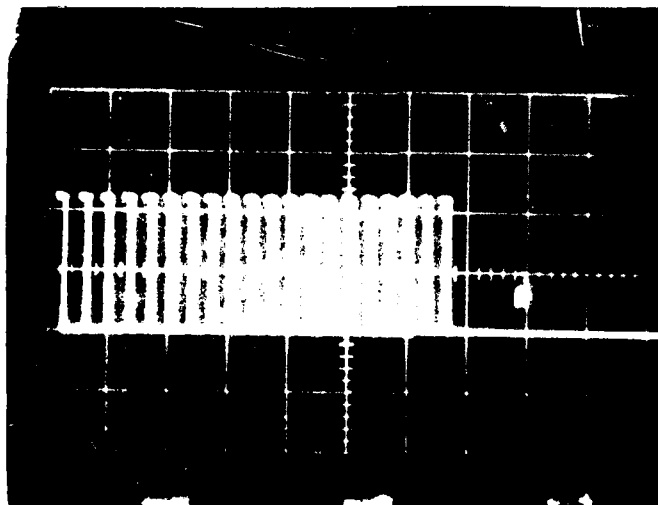

$T = 0.2 \text{ sec/cm}$
 $V = 5v/cm$

20 round burst of fire at 831 rounds/minute

Figure 12. Ballistics screen testing results (M-16 weapon tested)

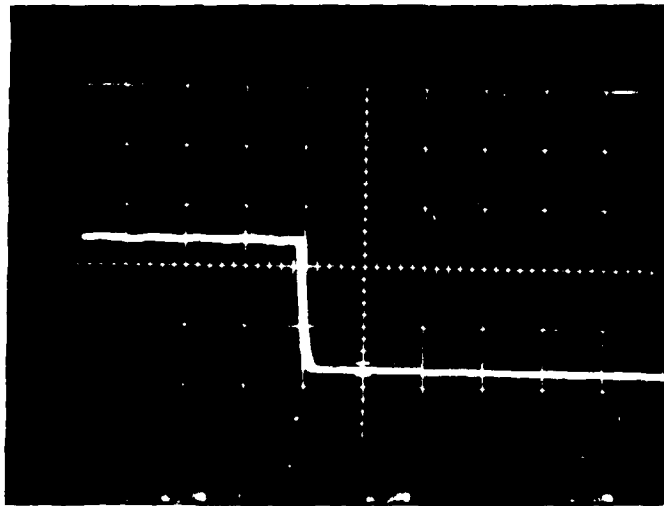

$v = 5V/cm$
 $T = 5ms/cm$

Figure 13. Radar cell mass motion detector testing results for one shot fired (M16 weapon tested)

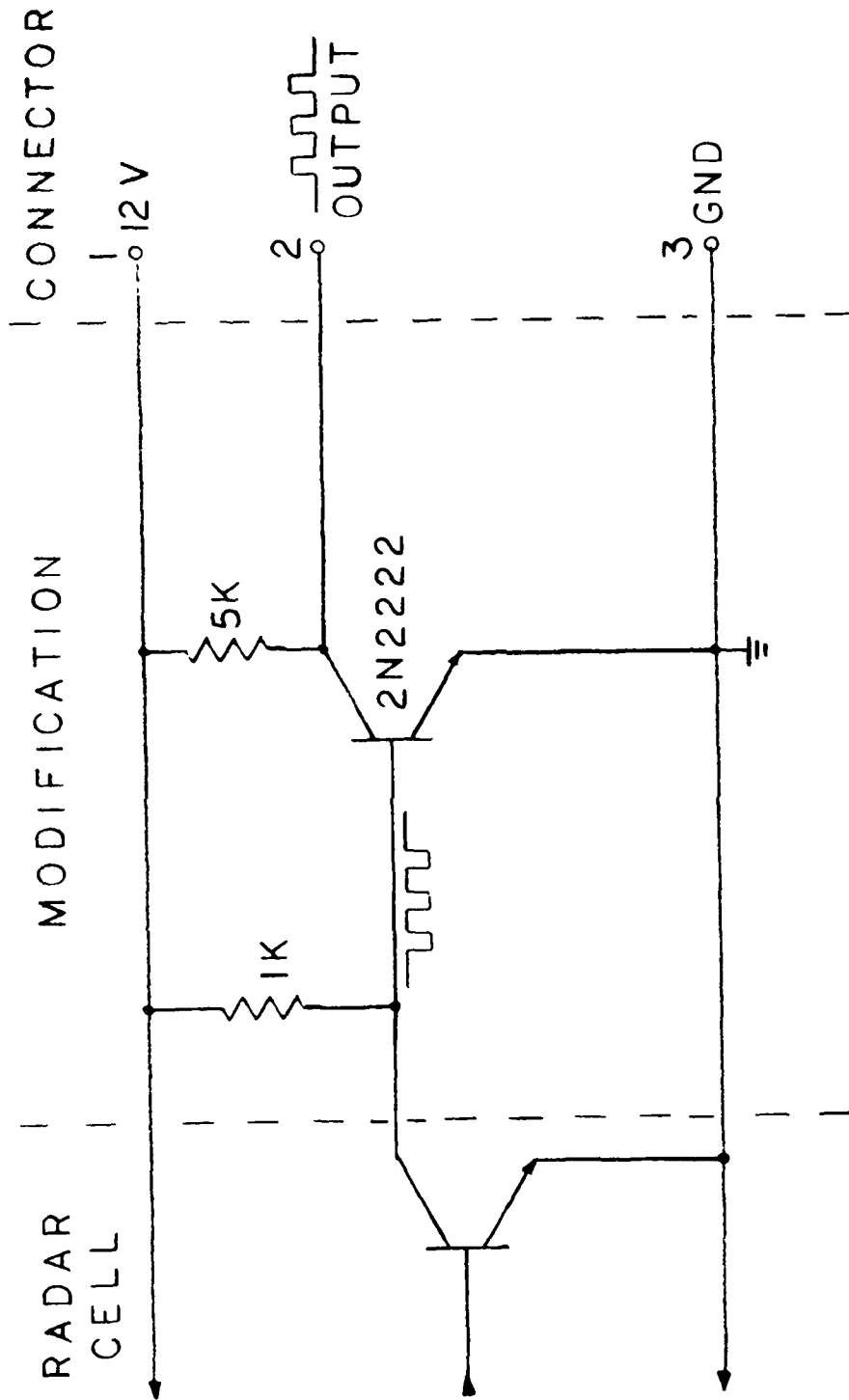

Figure 14. Radar cell mass motion detection system modification

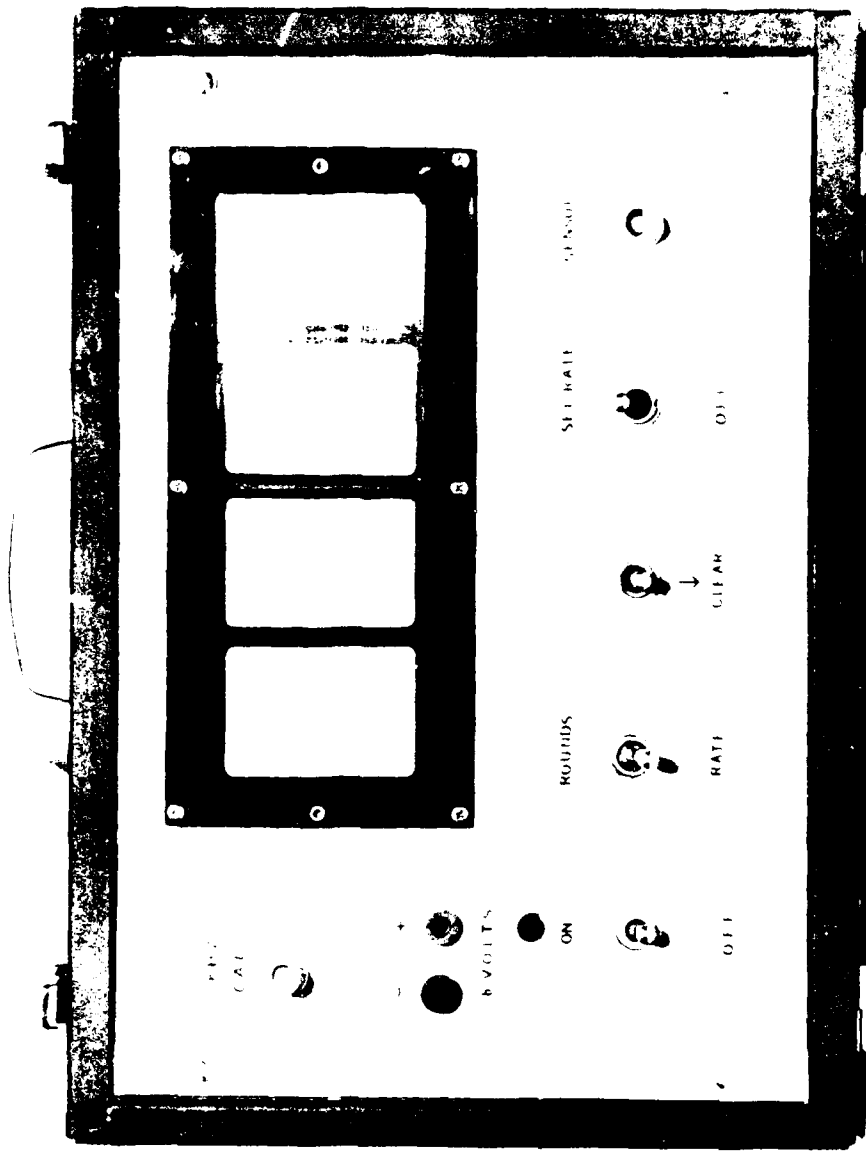

Figure 15. Rounds counter panel layout

APPENDIX
ROUNDS COUNTER ELECTRONICS

<u>Component*</u>	<u>Purpose</u>	<u>Input from</u>	<u>Output to</u>
Flip Flop #2 (CD-4013)	Enables dual up counter #1 (CD-4518) after first round is sensed (starts counting 1 kHz time pulses)	1. Sensor (I/O) 2. Multivibrator (CD-4098)	Dual up counter #1 (CD-4518)
Rounds Counter (MC-14534)	Stores the number of rounds detected by the sensor (Cumulative until reset)	1. Sensor (I/O) 2. Multivibrator (CD-4098)	1. Buffers #1 and #2 (MM70C97) 2. Inverting Buffer #1 (MM70C98)
Buffers #1 through #4 (MM70C97)	Provides BCD output of either rounds or calculated rate of fire to LCD decoder (DF-411)	1. Rounds Counter (MC-14534) 2. "Rounds-Rate" Switch (S-2)	1. LCD Decoder (DF-411) 2. Calculator (CTS-002-276-1754)
Multivibrator (CD-4098)	Clock Flip Flop #3 (CD-4013) at the end of a burst of fire.	Sensor (I/O)	1. Flip Flop #3 (CD-4013) 2. Reset Switch (S-3)
Flip Flop #3	Detects when the end of burst has occurred and enables 15.2 HZ calculator sequencing frequency.	1. Multivibrator (CD-4098) 2. Switch S-3 (clear)	1. Binary counter (CD-4040) 2. 4 to 16 line decoder #1 (CD-4514)
Debounce (MC-14490)	Clears binary counter (CD-4040) and 4 to 16 line decoder #1 (CD4514)	Switch S-4 (Set Rate)	1. Binary counter (CD-4040) 2. 4 to 16 line decoder #1 (CD-4514)
Binary Dividers (CD-4020 and CD-4024)	Divides 1 MHz oscillator frequency to produce 15.2 Hz calculator sequencing frequency	Oscillator (CD-4007)	1. Binary Counter (CD-4040) 2. 4 to 16 line decoder #1 (CD-4514) 3. Buffer #1 (MM70C97) 4. Rounds counter through S-2 (MC14534)

* See table A-1 and figure A-1.

<u>Component</u>	<u>Purpose</u>	<u>Input from</u>	<u>Output to</u>
Decade Dividers #1 through #3	Generates 1 kHz timing pulses from 1 MHz crystal frequency	Oscillator (CD-4007)	Dual up counter #1 (CD-4518)
4 to 16 line decoders #1 through #3 (CD-4514)	Provides the proper sequencing inputs to calculator for rate of fire calculations.	1. Binary Counter (CD-4040) 2. Binary Divider (CD-4024)	1. Inverting Buffer #1 (MM-70C98) 2. Calculator (CT5-002-276-1754) 3. Noninverting buffers # 1 through # 4 (MM-70C97)
Flip Flop #1 (CD-4013)	Enables either 4 to 16 line decoder #1 or #2 (CD-4514)	1. Debounce (MC-14490) 2. 4 to 16 line decoder #2 (CD-4514)	4 to 16 line decoder #1 (CD-4514)
Binary Counter (CD-4040)	Sequences and disables 4 to 16 line decoders #1 through #3 (CD-4514)	1. Binary divider (CD-4024) 2. Debounce MC-14490	4 to 16 line decoders #1 through #3 (CD-4514)
Inverting Buffer #1 (MM-70C98)	Enables the number of rounds that are applied to the calculator for rate of fire calculations	1. Rounds counter (MC-14534) 2. 4 to 16 line decoder #1 (CD-4514)	Calculator (CT5-002-276-1754)
Dual up counters #1 and #2 (CD-4518)	Counts the total number of 1 kHz clock pulses for a burst of fire.	1. Decade divider #3 (CD-4033) 2. Flip Flop #2 (CD-4013) 3. Switch S-3 (Clear)	Quad clocked D-latches #1 through #4 (CD-4042)
Quad clocked D-latches #1 through #4 (CD-4042)	Latches in the cumulative time of 1 kHz pulses for each round detected	1. Dual up counters #1 and #2 (CD-4518) 2. Switch S-3 (Clear)	Non-inverting buffers #1 through #4 (MM-70C97)
Non-inverting buffers #1 through #4 (MM-70C97)	Sequences "true" burst time to inverting buffer #2	1. Quad clocked D-latch # 1 through #4 (CD-4042)	Inverting buffer #2 (MM-70C98)

<u>Component</u>	<u>Purpose</u>	<u>Input from</u>	<u>Output to</u>
Inverting buffer #2 (MM-70C98)	Assures that a "0" is converted to a "10"	1. Non-inverting buffers #1 through 4 (MM-70C97) 2. 4 to 16 line decoder #3 (CD-4514)	Calculator (CT5-002-276-1754)
BCD Converter (MM-74C915)	Converts 7 segment data to BCD data for LCD decoder (DF-411)	Calculator (CT5-002-276-1754)	Buffer #4 (MM-70C97)
Calculator (CT5-002-276-1754)	Performs calculations for rate of fire.	All circuitry used for calculating rate of fire	BCD converter (MM-74C915)
LCD Decoder (DF-411)	Drives LCD display providing correct waveforms	Buffers #1 through #4 (MM-70C97)	LCD (Liquid crystal displays #1 through #4)

Table A-1. Related data-sheets

1. Motorola Inc., "MC14534B Real Time Decade Counter," Volume 5, Series B, Semiconductor Data Library, 1976, pp 5-357 to 5-362.
2. "MC-14490 Contact Bounce Eliminator," Volume 5, Series B, Semiconductor Data Library, 1976, pp 5-224 to 5-230.
3. Siliconix Inc., Data Sheet on "DF-411 - Four Digit LCD Decoder Driver," LSI Design Catalog, 1978, pp 3-11 to 3-17.
4. Crystaloid Electronics Co., Data Sheets on "K-5560 Liquid Crystal Display" and "5201-A LCD."
5. Radio Shack, "276-1754 Calculator Chip."
6. RCA Solid State

CD4098	Monostable Multivibrator	P.259
CD4013	Flip/Flop	P.75
CD4023	3-Input NAND Gate	P.67
CD4040	Binary Counter	P.107
CD4001	NOR Gate	P.44
CD4514	4 to 16 Line Decoder	P.288
CD4007	Inverter	P.56
CD4033	Decade Divider	P.111
CD4020	Binary Divider	P.107
CD4072	4 Input OR Gate	P.219
CD4518	Dual Up-Counters	P.292
CD4042	Quad Clocked Latch	P.154
CD4071	Quad 2-Input OR Gate	P.219
CD4025	3-Input NOR Gate	P.44
CD4002	4-Input NOR Gate	P.44

RCA COS/MOS Integrated Circuit Selection Guide, 1978.

7. National Semiconductor

"MM74C915 7 Segment to BCD Converter,"
MOS/LSI Databook, pp 11-46 to 11-49

"MM74C04 Hex Inverter," CMOS Databook, pp 1-3 to 1-6.

"MM70C97 Tri-State Hex Buffers," CMOS Databook, pp 1-174 to pp 1-178.

"MM70C98 Tri-State Hex Inverters," CMOS Databook, pp 1-174 to pp 1-178.

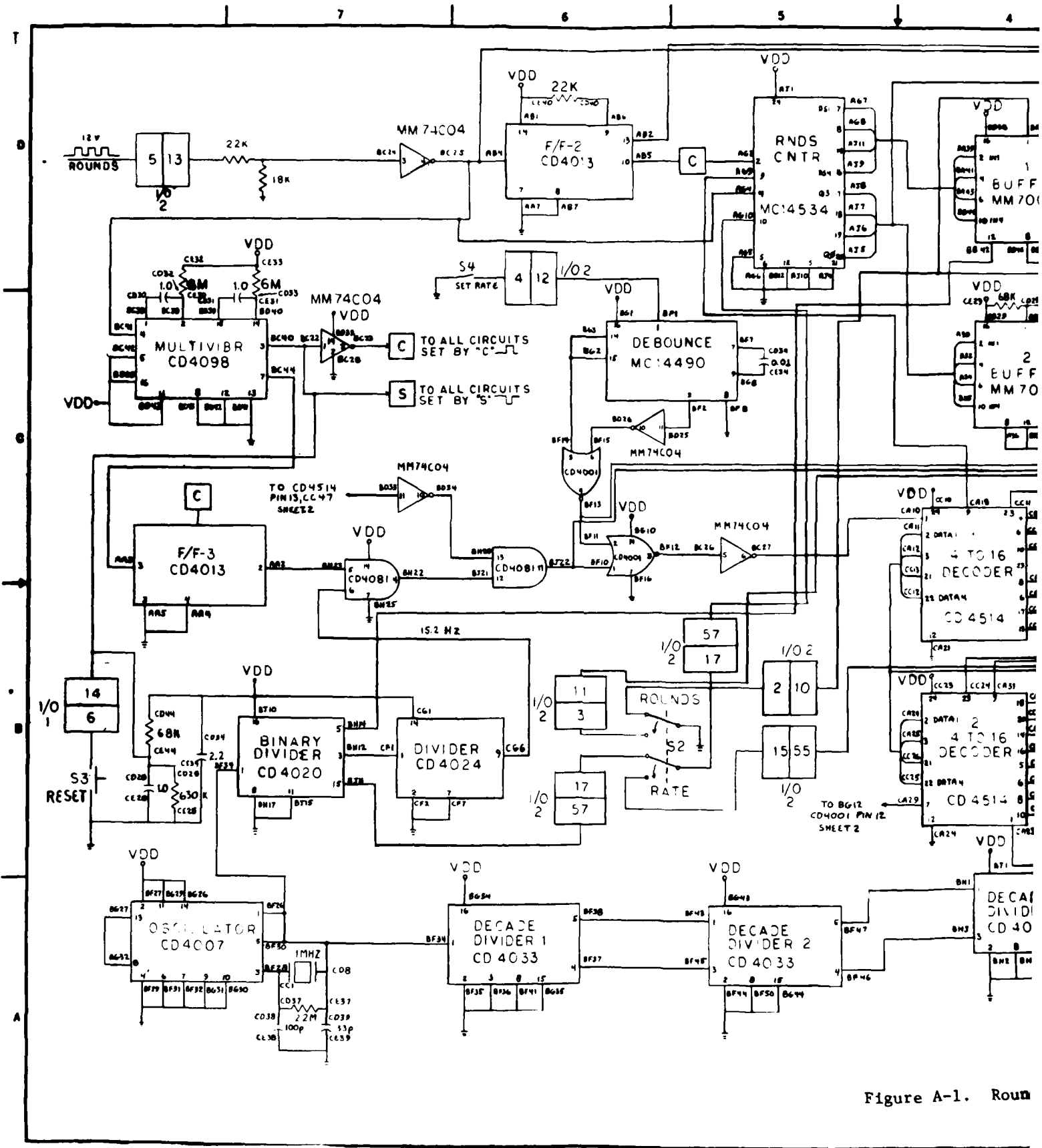
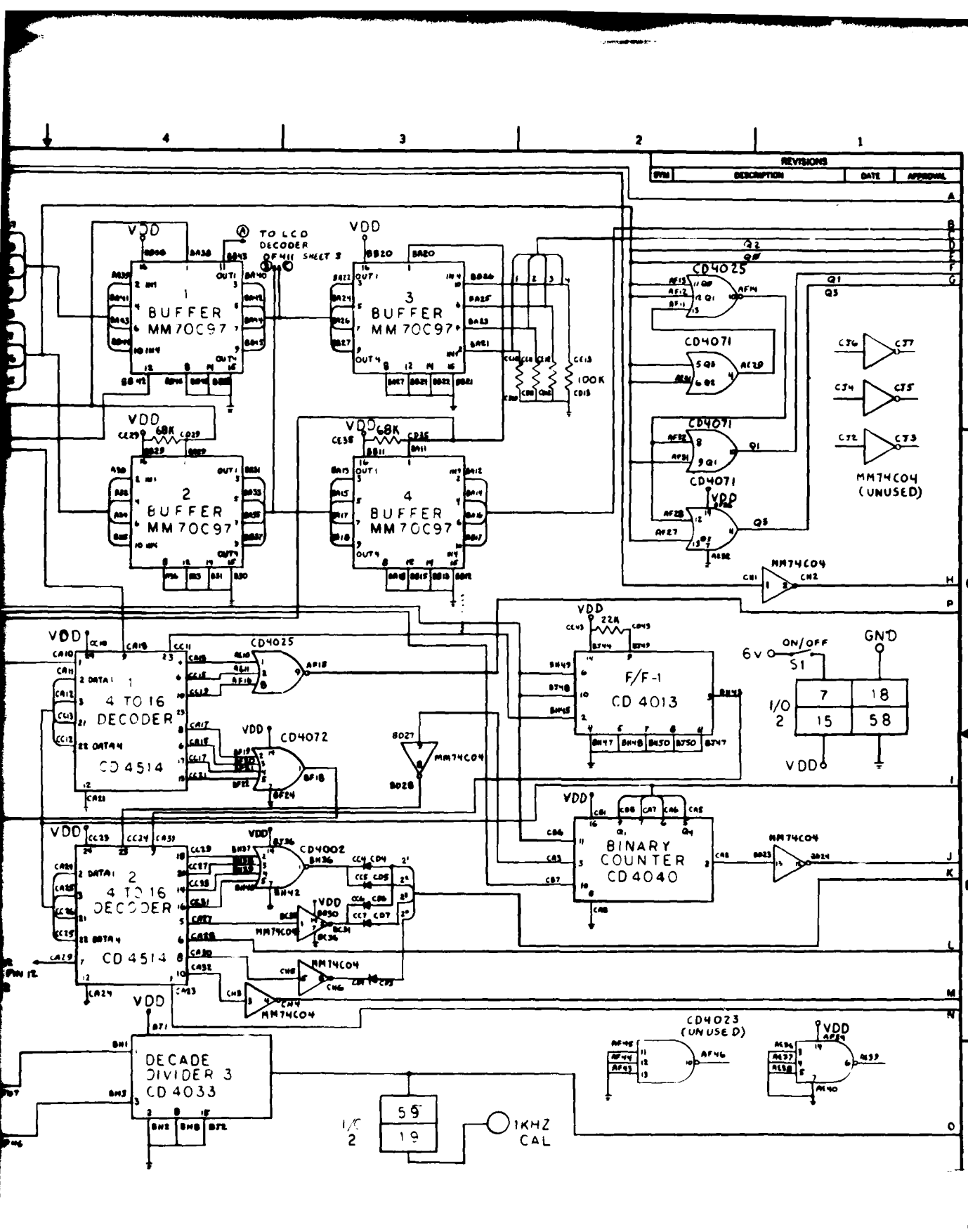

Figure A-1. Round



REVISIONS			
REV	DESCRIPTION	DATE	APPROVAL
070			

Figure A-1. Rounds counter

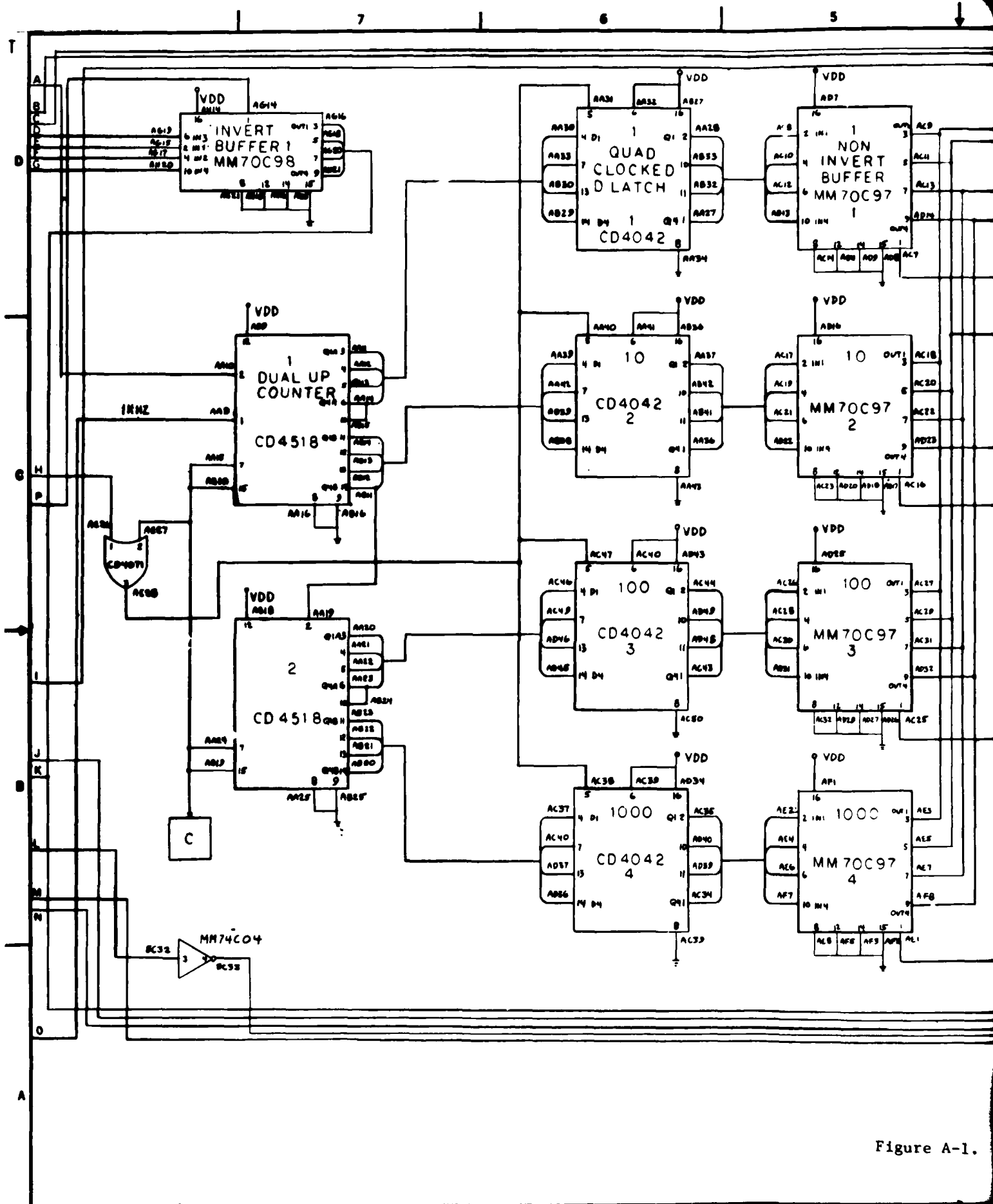
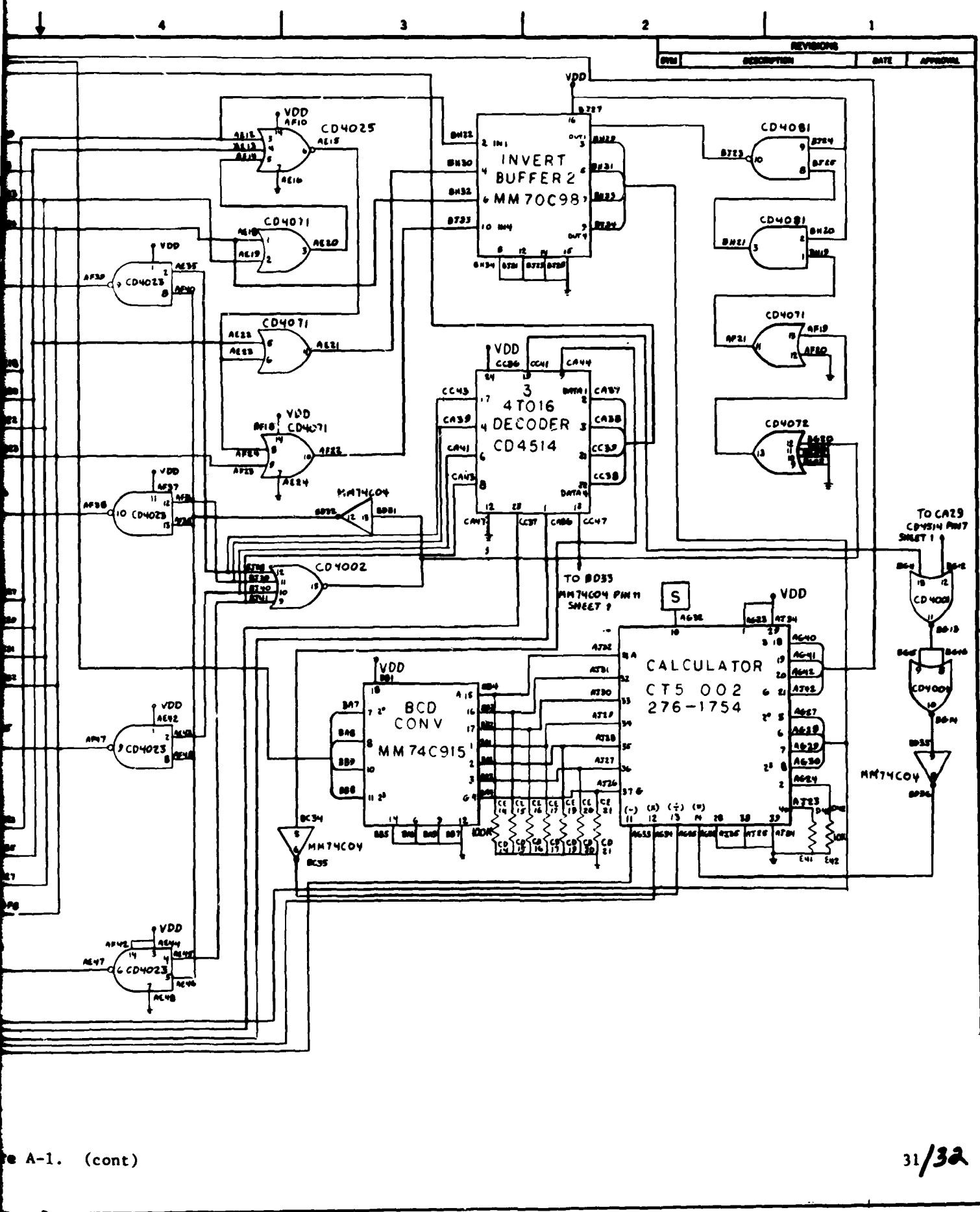

Figure A-1.



REVISIONS			
QWS	DESCRIPTION	DATE	APPROVAL

Sheet A-1. (cont)

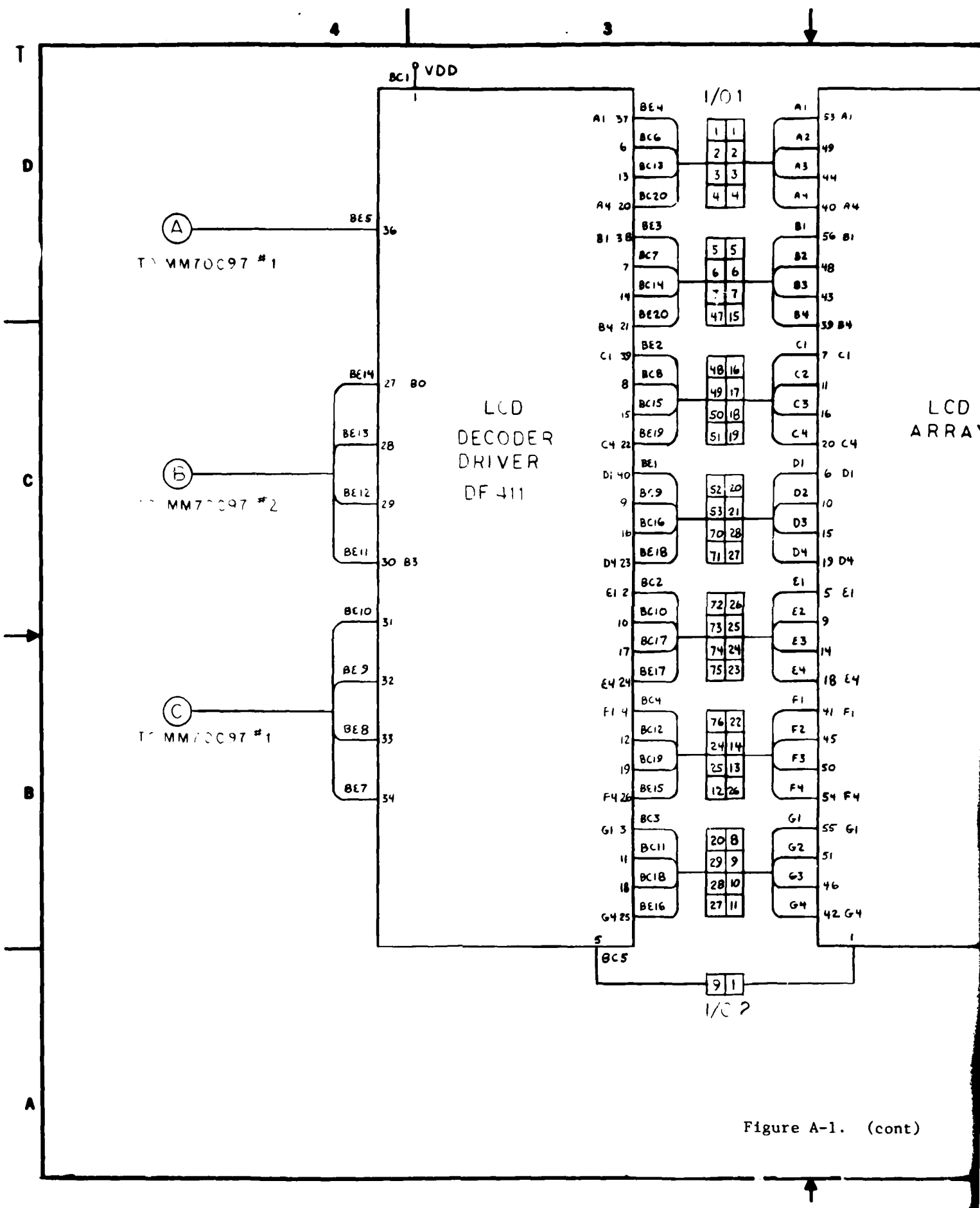

Figure A-1. (cont)

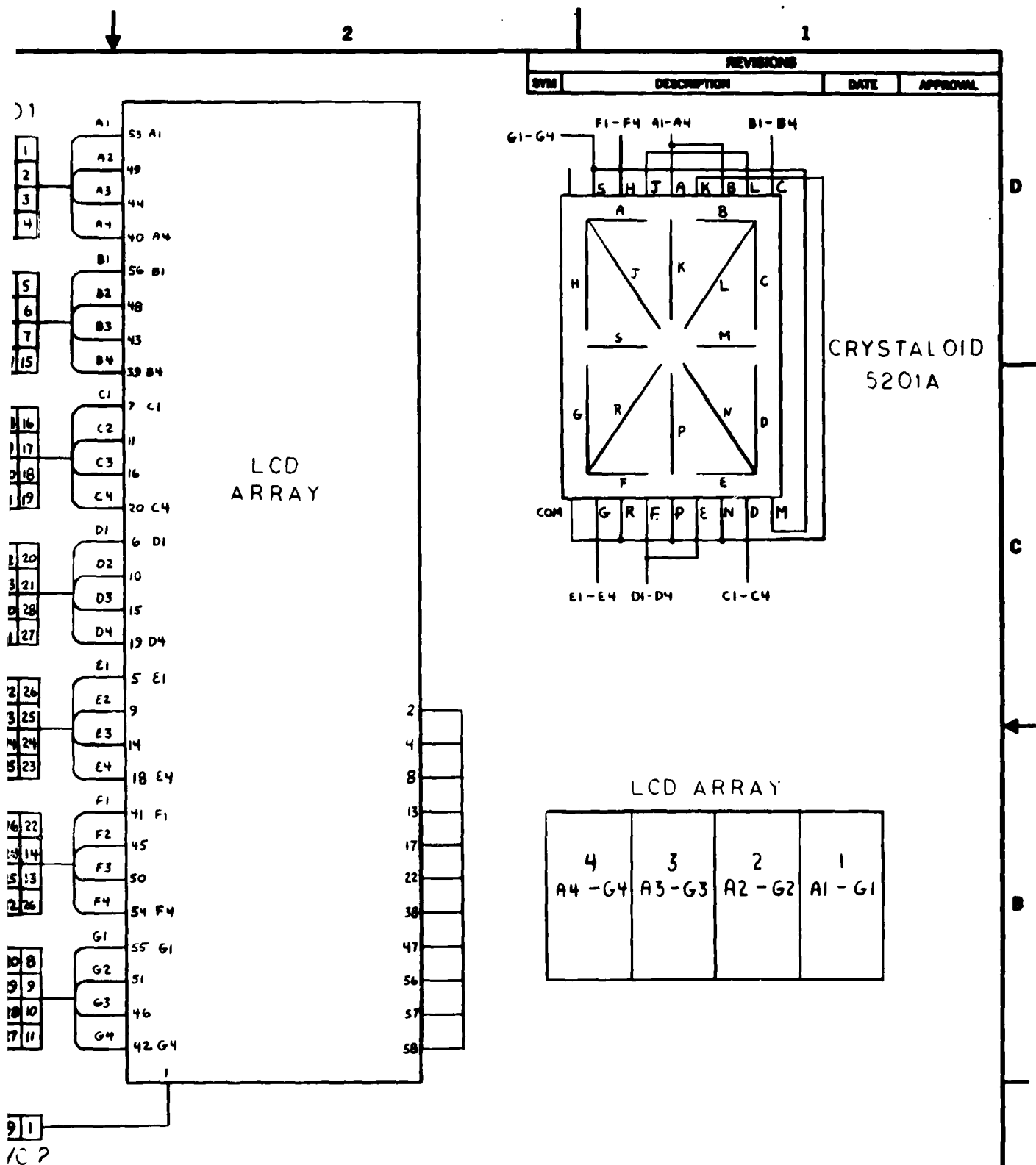

Figure A-1. (cont)

DISTRIBUTION LIST

Commander
U.S. Army Armament Research
and Development Command

ATTN: DRDAR-SC
DRDAR-SCJ
DRDAR-SCA
DRDAR-SCA-A
DRDAR-SCA-C
DRDAR-SCA-S (2)
DRDAR-SCA-T
DRDAR-SCA-W
DRDAR-TSE-SD (10)
DRDAR-LC
DRDAR-LCN
DRDAR-LCN-C (2)
DRDAR-SCF-C
DRDAR-TSS (5)
DRDAR-GCL

Dover, NJ 07801

Administrator
Defense Technical Information Center
ATTN: Accessions Division (12)
Cameron Station
Alexandria, VA 22314

Director
U.S. Army Materiel Systems
Analysis Activity
ATTN: DRXSY-MP
Aberdeen Proving Ground, MD 21005

Commander/Director
Chemical Systems Laboratory
U.S. Army Armament Research
and Development Command
ATTN: DRDAR-CLJ-L
DRDAR-CLB-PA
APG, Edgewood Area, MD 21010

Director
Ballistics Research Laboratory
U.S. Army Armament Research
and Development Command
ATTN: DRDAR-TSB-S
Aberdeen Proving Ground, MD 21005

Chief

Benet Weapons Laboratory, LCWSL
U.S. Army Armament Research
and Development Command
ATTN: DRDAR-LCB-TL
Watervliet, NY 12189

Commander

U.S. Army Armament Materiel
Readiness Command
ATTN: DRSAR-LEP-L
Rock Island, IL 61299

Director

U.S. Army TRADOC Systems
Analysis Activity
ATTN: ATAA-SL
White Sands Missile Range, NM 88002