

AD-A118 764

FREQUENCY ELECTRONICS INC NEW HYDE PARK NY
HIGH PERFORMANCE CRYSTAL OSCILLATOR DEVELOPMENT.(U)
JUL 82 J HO

F/G 9/1

F19628-80-C-0198

UNCLASSIFIED

RADC-TR-82-191

NL

1-1

DTIC



END
FILMED
9 82

DTIC

AD A118764

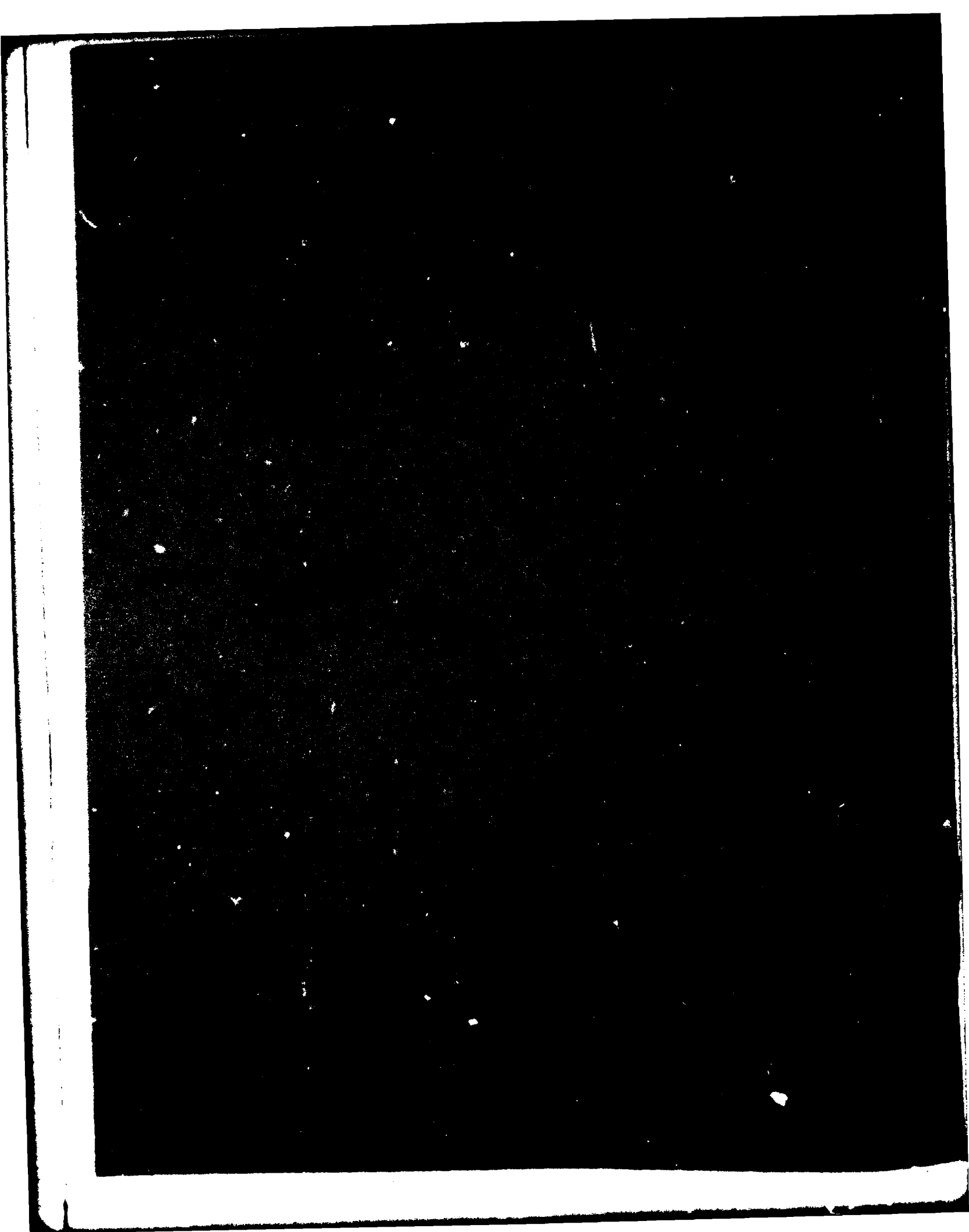

UNCLASSIFIED

SECURITY CLASSIFICATION OF THIS PAGE (When Data Entered)

REPORT DOCUMENTATION PAGE		READ INSTRUCTIONS BEFORE COMPLETING FORM
1. REPORT NUMBER RADC-TR-82-191	2. GOVT ACCESSION NO. ADA118764	3. RECIPIENT'S CATALOG NUMBER
4. TITLE (and Subtitle) HIGH PERFORMANCE CRYSTAL OSCILLATOR DEVELOPMENT		5. TYPE OF REPORT & PERIOD COVERED Interim Report 1 Oct 80 - 30 Apr 82
		6. PERFORMING ORG. REPORT NUMBER N/A
7. AUTHOR(s) John Ho		8. CONTRACT OR GRANT NUMBER(s) F19628-80-C-0198
9. PERFORMING ORGANIZATION NAME AND ADDRESS Frequency Electronics, Inc. 3 Delaware Drive New Hyde Park NY 11040		10. PROGRAM ELEMENT, PROJECT, TASK AREA & WORK UNIT NUMBERS 62702F 46001838
11. CONTROLLING OFFICE NAME AND ADDRESS Rome Air Development Center (ESE) Hanscom AFB MA 01731		12. REPORT DATE July 1982
		13. NUMBER OF PAGES 56
14. MONITORING AGENCY NAME & ADDRESS (if different from Controlling Office) Same		15. SECURITY CLASS. (of this report) UNCLASSIFIED
		15a. DECLASSIFICATION/DOWNGRADING SCHEDULE N/A
16. DISTRIBUTION STATEMENT (of this Report) Approved for public release; distribution unlimited		
17. DISTRIBUTION STATEMENT (of the abstract entered in Block 20, if different from Report) Same		
18. SUPPLEMENTARY NOTES RADC Project Engineer: Alfred Kahan (ESE)		
19. KEY WORDS (Continue on reverse side if necessary and identify by block number) Fast warm-up Crystal Oscillator		
20. ABSTRACT (Continue on reverse side if necessary and identify by block number) This contract calls for design, development, fabrication, and test of a fast warm-up Crystal Oscillator operating at 5 MHz & 10.05+ MHz. This first status report indicates that from the test results of the oscillators developed so far, further reductions of inner oven and oscillator assembly MASS is required. In addition, an approved method of coupling heat into the crystal blank will be worked upon. In order to reduce mass, redesign of the electronic circuitry from discrete circuits to IC and Hybrid (over)		

DD FORM 1473 EDITION OF 1 NOV 65 IS OBSOLETE

UNCLASSIFIED

SECURITY CLASSIFICATION OF THIS PAGE (When Data Entered)

UNCLASSIFIED

1 in. in

SECURITY CLASSIFICATION OF THIS PAGE (When Data Entered)

circuits is necessary. A new configuration is shown in the report. The key innovation of the design is to put the heater and temperature sensing devices on a ceramic disk, approximately 1 in diameter. A new Hybrid approach will permit the fastest warm-up ovenized oscillator of its kind and will out-perform the present model in reliability and quality.

UNCLASSIFIED

SECURITY CLASSIFICATION OF THIS PAGE (When Data Entered)

CONTENTS

	<u>PAGE</u>
INTRODUCTION	4
A. Construction of Working Models	5
B. Test Results of the New Oscillators	9
C. Comparison of 5 MHz and 10.05 ⁺ MHz Oscillators	14
D. Titanium Dewar Flask Status	15
E. Progress of SC Cut Crystals	17
F. Hardware Delivery	17
G. Objective for the Progress of the Next Period	18
H. Period from April 1, 1981 through April 30, 1982	21

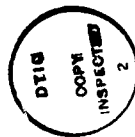

Accession For	
NTIS GRA&I	<input checked="" type="checkbox"/>
DTIC TAB	<input type="checkbox"/>
Unannounced	<input type="checkbox"/>
Justification	
By _____	
Distribution/	
Availability Codes	
Dist	Avail and/or Special
A	

LIST OF ILLUSTRATIONS

<u>FIGURE</u>		<u>PAGE</u>
1	"C" Size Crystal Holder	25
2	Mechanical Package of 5 MHz Oscillator	26
3	Oscillator PC Assembly	27
4	Inner Oven PC Assembly	28
5	Outer Oven PC Assembly	29
6	Internal Assembly	30
7	TO-8 Size Crystal Holder	31
8	Mechanical Package of 10.05 ⁺ MHz Oscillator	32
9	Oven Thermal Configuration of 10.05 ⁺ MHz Oscillator	33
10	Oven Thermal Configuration of 5 MHz Oscillator	33
11	Short Term Stability of Oscillators S/N 001 & 003	34
12	Long Term Stability of Oscillator S/N 001	35
13	Long Term Stability of Oscillator S/N 002	35
14	Phase Noise for Oscillator S/N 001 & 002	36

LIST OF ILLUSTRATIONS (CONTINUED)

<u>FIGURE</u>		<u>PAGE</u>
15	Warm-Up for Oscillator S/N 001	37
16	Warm-Up for Oscillator S/N 002	37
17	"g" Sensitivity for Oscillator S/N 001	38
18	"g" Sensitivity for Oscillator S/N 002	39
19	Frequency Vs. Temperature for Oscillator S/N 001 & 002	40
20	Warm-Up for Oscillator S/N 003	41
21	Warm-Up for Oscillator S/N 004	41
22	Frequency Vs. Temperature for Oscillator S/N 003	42
23	Frequency Vs. Temperature for Oscillator S/N 004	42
24	"g" Sensitivity for Oscillator S/N 003	43
25	"g" Sensitivity for Oscillator S/N 004	44
26	New OCXO Internal Sketch	45
27	New OCXO Configuration	46
28	Long Term Stability of Oscillator S/N 001	47
29	Long Term Stability of Oscillator S/N 002	47
30	Electron Beam Welding Equipment	48
31	Crystal Enclosure, Physical Dimensions	49
32	Hybrid Oven Flat-pack	50
33	Hybrid Oven Flat-pack, Schematic Diagram	51

INTRODUCTION.

This report covers the research activities accomplished during the period from October 1, 1980 to April 30, 1982.

Sections A through G cover the basic period, from October 1, 1980 through April 1, 1981. Section H covers the follow-on period from April 1, 1981 through April 30, 1982. During this phase, additional data on long-term characteristics of the crystals were obtained. In addition, internal FEI funds were expended to establish future technologies.

The objective of these research activities is to develop, design and manufacture a line of high performance oscillators to meet the need of future military communication, navigation, and radar surveillance applications. The following are the key features that this high performance oscillator must have:

1. Use of the newly developed SC cut crystals.
2. Fast warm-up, with low power consumption.
3. Very low "g" sensitivity and high vibration immunity.
4. Ultra clean output signal without the use of crystal filter.
5. High frequency stability for both short term and long term.
6. Reliable, small and lightweight design.

At this time, we feel that we have developed and achieved most of the essential parameters for these high performance oscillators. However, additional continuing work is still needed before the new generation of oscillators can be produced economically in the production basis.

This report will cover the following areas:

1. The new model of 5 MHz and 10.05⁺ MHz oscillator design and construction.
2. The test results of the oscillators.
3. Comparison of the 5 MHz and 10.05⁺ MHz oscillator.
4. Titanium Dewar flask status.
5. Progress of SC cut crystal.
6. Hardware delivery.
7. Proposed objective for the next period.
8. Period from April 1, 1981 through April 30, 1982.

A. Construction of Working Models.

During this period, two different types of oscillators have been designed, packaged and tested for two different sizes and frequencies of SC cut crystals. They are described in detail in the following paragraphs.

A-1. The first oscillator is designed for use of the 5 MHz, 5th overtone, SC cut, bi-convex crystal, with three point mount "C" size holder (see Figure 1). The oscillator's mechanical design is shown in Figure 2, and its internal subassembly and printed circuit boards are shown in Figures 3, 4 and 5. Discrete electronic components were used for this design to verify the circuit stability. The size of the internal assembly is $1 \frac{3}{16}$ " in diameter x 4" long, as shown in Figure 6. The overall oscillator (Model FE-2188B) measures 2" x 2" x 5", has a volume of 20 in³, and a total weight of 14.8 oz.

The oscillator circuit design consists of crystal C mode frequency selection and B mode frequency rejection elements, AGC circuit for reliable crystal starting current, optimized operating crystal current, and a buffer output stage for interface isolation.

A unique thermal oven control system has been developed for fast warmup. This consists of a three stage cascade control inside a Dewar flask configuration. Three heater elements are used; they are outer oven heater, inner and booster heaters.

With the oscillator turn-on from cold start, all three heaters will be fully on. When the crystal reaches its operating turn-over temperature, approximately 2 to 3 minutes, the booster heater (high power) will disable itself permanently, and leave the inner oven heater (low power) for maintaining the proper temperature. The outer oven heater will stay controlled at a temperature approximately 10°C lower than the inner oven temperature so that a very low inner oven heater power will be required for sustaining control of the crystal temperature.

A-2. The second oscillator is designed for the 10.05+ MHz, 3rd overtone, SC cut crystal, housed in a TO-8 crystal holder (Figure 7). The purpose of this design is to simulate the minimum mass, and maximum heater power required to achieve a fast warmup oven control system, using foam as thermal insulation material without the use of a Dewar flask. The mechanical package is shown in Figure 8. The overall oscillator measurements are 3" x 3" x 1.97", and a volume of 20.68 in³ and a weight of 13 oz.

This oscillator is designed with self-limiting AGC systems, and has the great advantage of using few circuit components. It will be much simpler for circuit layout and packaging. However, its long-term ultimate stability performance needs to be evaluated.

This oscillator uses the same oven heater control system as described above, except that its thermal package configuration is different. (See Figures 9 and 10.)

Crystal Holder Size.

"C" size is suitable for design. Crystal has blank size of 0.4" to 0.6" diameter, for frequency range of 4 MHz to 10 MHz 3rd or 5th overtone, or 2 MHz to 8 MHz Fundamental crystals.

TO-8 is suitable for design crystal and has maximum blank size of 0.4" diameter for frequency range of 5 MHz to 20 MHz, Fundamental or 10 MHz to 40 MHz, 3rd or 5th overtone crystal.

B. Test Results of the New Oscillators.

B-1. Two of the 5 MHz oscillators were built and tested. They are Model FE-2188B, Serial Nos. 001 and 002. Generally the test results were satisfactory.

B-1.1 The oscillator exhibited very good short-term stability. The result is shown in Figure 11. The data was measured between S/N 001 and S/N 002. They are:

4PP10¹⁰/100 μS

1PP10¹⁰/1 mS

2PP10¹¹/10 mS

5PP10¹²/100 mS

1.5PP10¹²/1 Sec

1.2PP10¹²/10 Sec

The flicker level was estimated to be in the 10⁻¹³ range.

B-1.2 The long-term stability of oscillator S/N 001 was good. After warmup of 4 days, the aging rate for the next 10 days was 5PP10¹¹/day and reduced to 5PP10¹²/day after another 15 days. The plotted data is shown in Figure 12.

B-1.3 The long-term stability of 5 MHz oscillator S/N 002 was relatively poor. After 4 days warmup, the aging rate was +4PP10¹⁰/day. After 15 days of operation, the aging rate was reduced to 2PP10¹⁰/day. This shows that additional work on the SC cut crystal is still needed to produce consistent good aging crystals. Plotted data is shown in Figure 13.

B-1.4 The phase noise characteristics obtained between S/N 001 and S/N 002 is shown in Figure 14. The results are:

<u>Offset Frequency From Carrier</u>	<u>S.S S/N Ratio (1 Hz BW)</u>
1 Hz	-110 dB
10 Hz	-132 dB
100 Hz	-143 dB
1 kHz	-154 dB

From the above data, the oscillator output floor noise is excellent, without the use of a crystal filter to obtain -154 dB (1 kHz away from carrier). This will definitely reduce production costs in the future.

B-1.5 The frequency warmup characteristic is shown in Figures 15 and 16. The input power for the initial 3 minutes of warmup is 20 watts and after booster heater cut-off, the input power will reduce to less than 2.0 watts in less than 5 minutes.

The frequency is stabilized to within $2PP10^7$ in 5 minutes and less than $2PP10^9$ in 7 minutes. These results are dramatic improvements from a typical warmup of 30 minutes to 2 hours to obtain stability of $2PP10^9$. Figures 15 and 16 have shown slight frequency overshoot in the order of $3PP10^7$ for oscillator S/N 001 and less than $1PP10^7$ for oscillator S/N 002. This is due to the SC cut crystal angle cutting accuracy. This is a typical distribution of crystal characteristics and also the inner oven control dumping characteristic. The slight frequency overshoot has an advantage for a normal phase-lock loop system high-precision oscillator. It will have a Vco range of 1 to $2PP10^7$, and the overshoot during the warmup within the VCO range would help to speed-up phase-lock time.

B-1.6 Although the AT cut 5 MHz 5th overtone crystal has the same oven control system, the frequency overshoot is ten times that of the SC cut crystal. A typical frequency overshoot in the range of $1PP10^6$ that is totally out of oscillator VCO range, is not compatible with the phase-lock system.

Therefore, the SC cut crystal is especially desirable for its compensated thermal characteristic for use in a fast warmup, phase lockable high performance oscillators.

B-1.7. The "g" sensitivity of this model is shown in Figures 17 and 18. The result is less than $4\text{PP}10^{10}/\text{g}$ for S/N 001, and $3\text{PP}10^{10}/\text{g}$ for S/N 002*. The result of improvement in "g" sensitivity will enhance the yield of crystal productivity. Research is still being pursued so that a greater yield in "g" sensitivity can be accomplished.

B-1.8 The preliminary frequency stability over the temperature range from -10°C to $+50^{\circ}\text{C}$ is less than $2\text{PP}10^{10}$ for both S/N 001 and S/N 002 and is shown in Figure 19. Because this data was taken with the use of a pyrex flask, the final temperature vs. frequency data will be retaken when the pyrex flask is replaced with a titanium flask, and we feel the result will be very compatible.

*This compared to a typical AT cut crystal of $1 - 2\text{PP}10^9/\text{g}$ was a very significant improvement.

B-2. The 10.05⁺ MHz oscillator, Model FE-2173A, S/N 003 and S/N 004 test results are as follows:

B-2.1 The warmup time for both oscillators is less than 2 minutes to reach 1PP10⁷, and less than 5 minutes to stabilize to 1PP10⁹. Figures 20 and 21 show these results. The input peak power is 18 watts during turnon for 1 1/2 minutes, then reduces to less than 2 watts in 5 minutes.

B-2.2 The frequency stability from -10°C to +50°C is 2PP10⁹ for oscillator S/N 003, Figure 22, and 2.2PP10⁹ for oscillator S/N 004, Figure 23.

B-2.3 The 'g' sensitivity for oscillator S/N 003 is 5PP10¹⁰/g, Figure 24, and for S/N 004 is 6PP10¹⁰/g, Figure 25.

B-2.4 The long-term stability of the 10.05⁺ MHz oscillator after a warmup of 15 days is 5PP10¹⁰/day.

C. Comparison of 5 MHz and 10.05⁺ MHz Oscillator.

C-1. The major difference between the two oscillators are the physical thermal package, (a) the 5 MHz uses a Dewar flask, and the 10.05⁺ MHz uses foam as insulation, (b) the 5 MHz oscillator uses a 5th overtone crystal in a "C" size crystal holder and the size of the inner oven package is almost three times that of the 10.05⁺ MHz oscillator, which uses a TO-8 crystal holder, in the fundamental mode. Because of the differences, the 10.05⁺ MHz oscillator only took 2 minutes warm-up time for the frequency to stabilize at $1PP10^7$ and the 5 MHz oscillator took 5 minutes for frequency to stabilize at $1PP10^7$. Therefore, it is obvious that we must reduce the 5 MHz oscillator inner oven assembly and thermal path to the crystal in order to further improve the warm-up time.

C-2. The frequency temperature sensitivity data shows that the 5 MHz oscillator is much better than the 10.05⁺ MHz oscillator, which is mainly due to the over-all thermal package. The Dewar flask utilized by the 5 MHz oscillator has a much better thermal insulation characteristic than the 10.05⁺ MHz oscillator, which does not utilize the Dewar flask. This is the key reason that the Dewar flask should be used in the future final oscillator, and the 10.05⁺ MHz oscillator package will not be utilized as a

final redesign. This oscillator package, however, without the use of the Dewar flask, is still a good research tool as an oscillator test bed for determining other important crystal parameters.

C-3. The "g" sensitivity results showed that the 5 MHz oscillator is better than the 10.05⁺ MHz oscillator by a factor of almost 2. This resulted from the basic crystal design and its fabrication process particularly in the area of the crystal support structure, since a better balance can be achieved with the 5 MHz crystal design rather than the 10.05⁺ MHz crystal design.

D. Titanium Dewar Flask Status.

The history of using the Dewar flask for high precision crystal oscillators has dated back two decades. The thermal insulation characteristic of the Dewar flask is very desirable for stabilizing quartz crystals in the precision oscillator application. The Dewar flask also consumes much less power compared with other insulating material in the same configuration.

Dewar flasks commercially have been made from pyrex or other glass materials. Under severe environmental conditions such as vibration and shock, the pyrex or glass material may break. Development efforts have been made in past years to produce flasks of steel material. The results are not satisfactory because the

heat transfer coefficient and slow outgas characteristic is poor within the vacuum envelope. This limits the life of the flask.

The development of making flasks with titanium material should be continued. It offers the best heat transfer coefficient and because titanium is a getter material in vacuum conditions, it will help improve the thermal insulation quality for long term usage.

The titanium flask measures smaller in size, lighter in weight and has a better insulation characteristic compared with the similar pyrex flask.

Titanium flask development is essential for the future precision high performance oscillator because it offers all the necessary elements required of a good precision oscillator. It reduces power consumption, size, weight, and most of all, it will meet all military environmental requirements as a final high performance oscillator.

The initial production of a titanium flask is being fabricated at FEI. Currently, the flask has been subcontracted for welding, and it is expected to be completed by May 30, 1981. It will then be processed at FEI for cleaning, vacuum bake out and sealing. They are scheduled for completion by June 30, 1981. At the present time, FEI has purchased E-B Welding equipment to be installed in our new manufacturing plant by late 1981. At that time, FEI will be fully equipped to produce titanium flasks without the assistance of subcontractors.

E. Progress of SC Cut Crystals.

Design and fabrication of various SC cut crystals are in progress and research and development continues. SC cut crystals are under study for contract DAAK20-79-C-0272, U.S. Army Electronics Research and Development Command, Fort Monmouth, N.J. Copies of the reports and test results may be obtained. The studies are of great assistance to the design and production of the ultimate SC cut crystal oscillators.

F. Hardware Delivery.

Four working models are ready for delivery. Two of the 5 MHz oscillators, S/N 8117-001, 8117-002 and two 10.05⁺ MHz oscillators, S/N 8117-003, 8117-004.

G. Objective for the Progress of the Next Period.

G-1. Table I shows a brief comparison of the performance of the two model oscillators and objective specification requirements as well as new expected performance for the future new OCXO model oscillators.

G-2. Based on the test results of the four test model oscillators, we have demonstrated the most important parameters. There is still more data needed to be obtained from the test oscillators. They are:

- (1) Retest temperature frequency coefficient with titanium flasks.
- (2) Evaluate and test the vibration frequency characteristics.
- (3) Frequency repeatability at different ambient temperature and different power off and on cycles.

G-3. Additional 5 MHz model oscillators need to be built to add a greater test data base. The distribution of variation of performance parameters can then be evaluated.

G-4. In the next period, we will redesign the oscillators to include some of the new ideals and features learned from the present test models.

- (1) Improve the 5 MHz oscillator warm-up time to 1 1/2 minutes for the frequency to stabilize at $1PP10^9$.
- (2) The present 5 MHz model oscillator contains discrete standard MIL-part components and has been packaged to its maximum density. In order to improve the warm-up time, it is apparent that future reductions of inner oven and oscillator assembly mass is essential, as well as the method of coupling heat into the crystal blank.
- (3) In order to reduce the mass of the oscillator assembly, redesign of the electronic circuitry from discrete components to IC and hybrid circuits will be necessary. Figure 26 is the sketch for the repackaging. The new design will reduce the over-all size from 2"x2"x5" to 1.6"x1.6"x3", the volume from 20 in³ to 7.68 in³, and the weight from 14.8 oz to 7 oz. The new configuration is shown in Figure 27.

(4) The key innovation of this redesign is to put heater and temperature sensing devices on a ceramic disk of approximately 1" in diameter, which will conduct heat directly to the crystal pins, crystal supports and then to the crystal blank. The heater and electronic hybrid circuit arrangements are shown in Figure 26.

G-5. FEI is presently hybridizing many electronic packages for programs such as the NAVSTAR Cesium Beam frequency standard and Galileo OCXO, extensively to reduce size, weight and power. We expect to incorporate all the new innovations and techniques into the new fast warm-up oscillators. They will out-perform the present model in reliability and quality.

G-6. Automation of computer data collection and testing is recommended for future production needs. This will greatly reduce the cost of man-hours for alignment, testing and recording the future production oscillator units.

G-7. We feel that with all of the above redesign and modification, the new oscillator will perform in a manner shown in Table I.

H. Period Covering April 1, 1981 Through April 30, 1982.

During the period of April 1, 1981 through April 30, 1982, FEI continued to obtain the long term characteristics of the clock already fabricated, and at the same time expended significant capital and research funds provided by FEI to establish the technology which will enable the program to proceed and obtain the detailed objectives described in Section G of this report.

1. We continued the long term aging characteristics of the clock and took detailed data on S/N 001 and 002. As evidenced by Figure 28, S/N 001 (the low aging clock) continued on the positive aging for a period of one month (August, 1981), then it gradually changed to negative aging. Its slope at last three months (February, March and April, 1982), was $-2.7 \text{ PP}10^{11}/\text{day}$ and still continues on negative aging. And S/N 002, as shown in Figure 29, improved positive aging from approximately $2 \text{ PP}10^{10}/\text{day}$ to present $3 \text{ PP}10^{11}/\text{day}$.

2. The titanium dewar flasks obtained from the outside sources presented workmanship problems and produced a very low yield. Most of the flasks leaked. In January, however, we did receive the electron beam welding apparatus at FEI and during the period of February thru April 30 fabricated 18 titanium dewar flasks with excellent performance characteristics. FEI is convinced that

there are no technical difficulties in fabricating the titanium dewar flasks, provided good techniques are employed in conjunction with the electron beam welding and the necessary precautions of surface preparation are obeyed. The objective in the future is to find the necessary techniques to produce the dewar flasks more economically. Figure 30 shows the photograph of the electron beam welding equipment.

3. During this period FEI moved into their new headquarters at 55 Charles Lindbergh Blvd., Mitchel Field, N.Y. We are confident that the future research and performance of the oscillator will be enhanced by the decision of putting thin and thick film crystals and electron beam welding in a clean room environment. The yield and performance in the past three months shows a very positive trend.

4. In order to obtain our objectives in Section G of this report, we had to reduce mass and hybridize the circuitry. FEI is now in full operation in the thick film facility. This will enable the program to get quick reaction, quality and reliability in the pursuit of hybridizing the oscillator. FEI is now in

production making "s" level parts for the GPS Navstar program, and in many other aerospace applications. Six different hybrids covering the range from DC to 400 MHz have successfully been produced for use in the GPS cesium clock apparatus.

5. In the development of SC cut crystals, FEI has obtained reasonable yields in low g sensitivity crystals, and what is most important, in order to assist the reduction of size, mass, and improve thermal coupling, we are now under contract with ERADCOM, (Contract No. DAAB07-82-C J052) to fabricate the SC cut resonators in ceramic holders. Figure 31 shows the physical dimension of the crystal enclosure. Our preliminary analysis indicates that thermal coupling to the resonator should be faster than the "C" holder enclosure used in our experiments to date.

6. FEI has completed a preliminary design for a Hybrid Oven Control Circuit in a Flat-pack (Refer to Figures 32 and 33).

TABLE 1

COMPARISON TABLE OF PRESENT MODEL AND FUTURE NEW OCXO

	PRESENT OCXO	SPECIFICATION REQUIREMENT		(FUTURE) NEW OCXO		
ITEM	5 MHz	10.05+ MHz	5MHz	10.23MHz	5 MHz	10.05+ MHz
Volume	20 in ³	20.68 in ³	10 in ³	10 in ³	7.68 in ³	7.68 in ³
Warm-Up Time	5 min. TO 2PP10 ⁷	2 min. TO 2PP10 ⁷	2 min. TO 1PP9	2 min. TO 1PP9	1 1/2 mins. TO 1PP9	1 1/2 mins. TO 1PP9
Short-Term Stability	1.5pp12/sec	5 pp11/Sec	9pp13/1 to 100 Sec	9pp13/1 to 100 Sec	5PP10 ¹³ /sec	7PP12/sec
"g" Sensitivity	3 PP10 ¹⁰ /g	6 PP10 ¹⁰ /g	1PP10/g	1PP10/g	5 PP10 ¹¹ /g	2-3 PP10 ¹⁰ /g
Aging	5 pp10 ¹¹ /day After 4 Days	5 pp10/day After 15 Days	1pp10/day After One Day	1pp10/day After One Day	2-3 PP10 ¹² /day After 7 Day	5 PP11/day After 7 Days
Input Power After Warm-Up	1.7 Watts	2.0 Watts	0.6 Watts	0.6 Watts	0.6 Watt	0.6 Watt
Phase Noise (1 Hz BW)	10 Hz-132 dB 100 Hz-143 dB 10kHz-154 dB	115 dB 122 dB 138 dB	10 Hz-130 dB 100 Hz-155 dB 10kHz-165 dB	-124 dB -149 dB -159 dB	10 Hz 135 dB 100 Hz 150 dB 10kHz 160 dB	120 dB 127 dB 145 dB

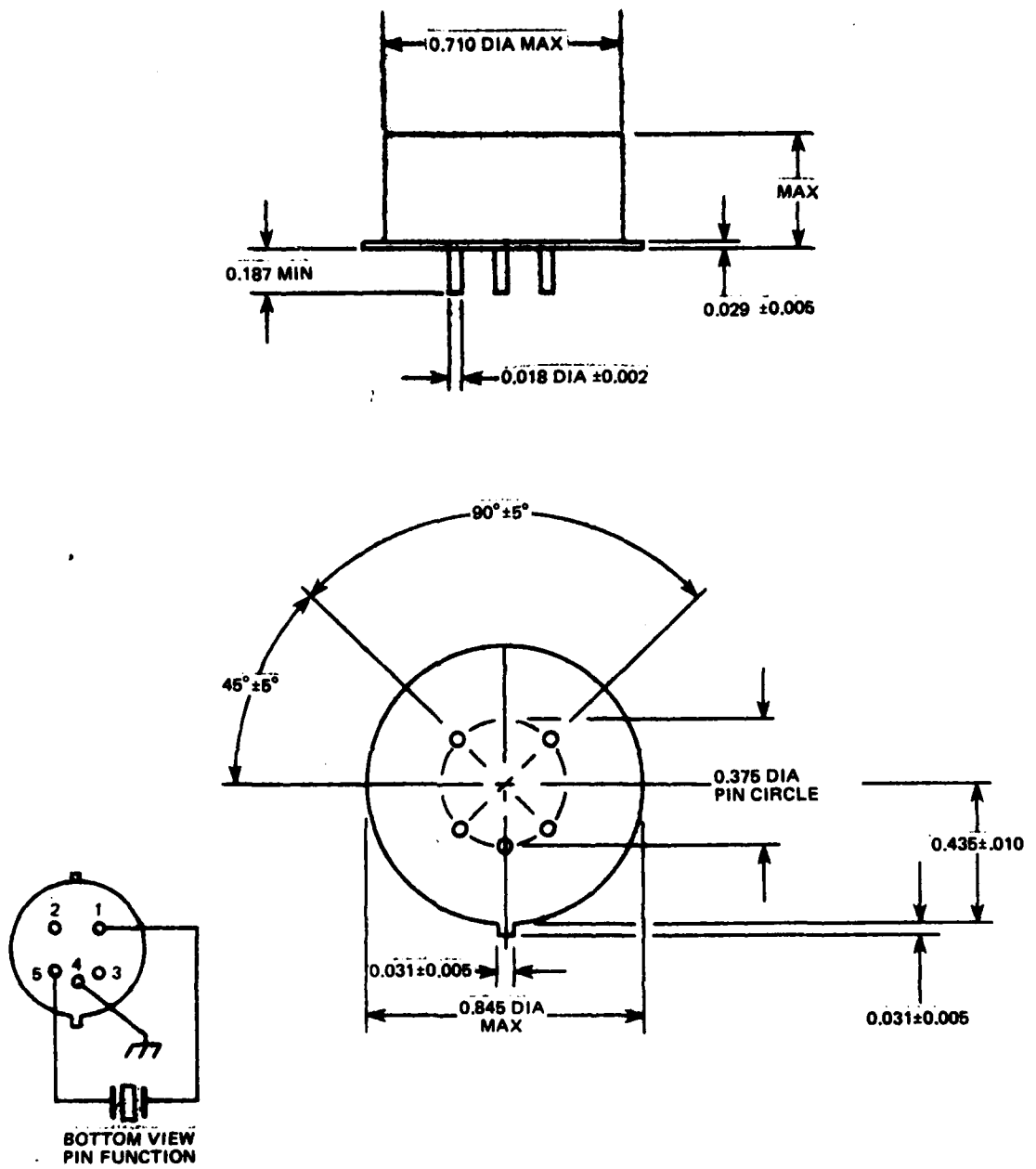

Figure 1. "C" Size Crystal Holder

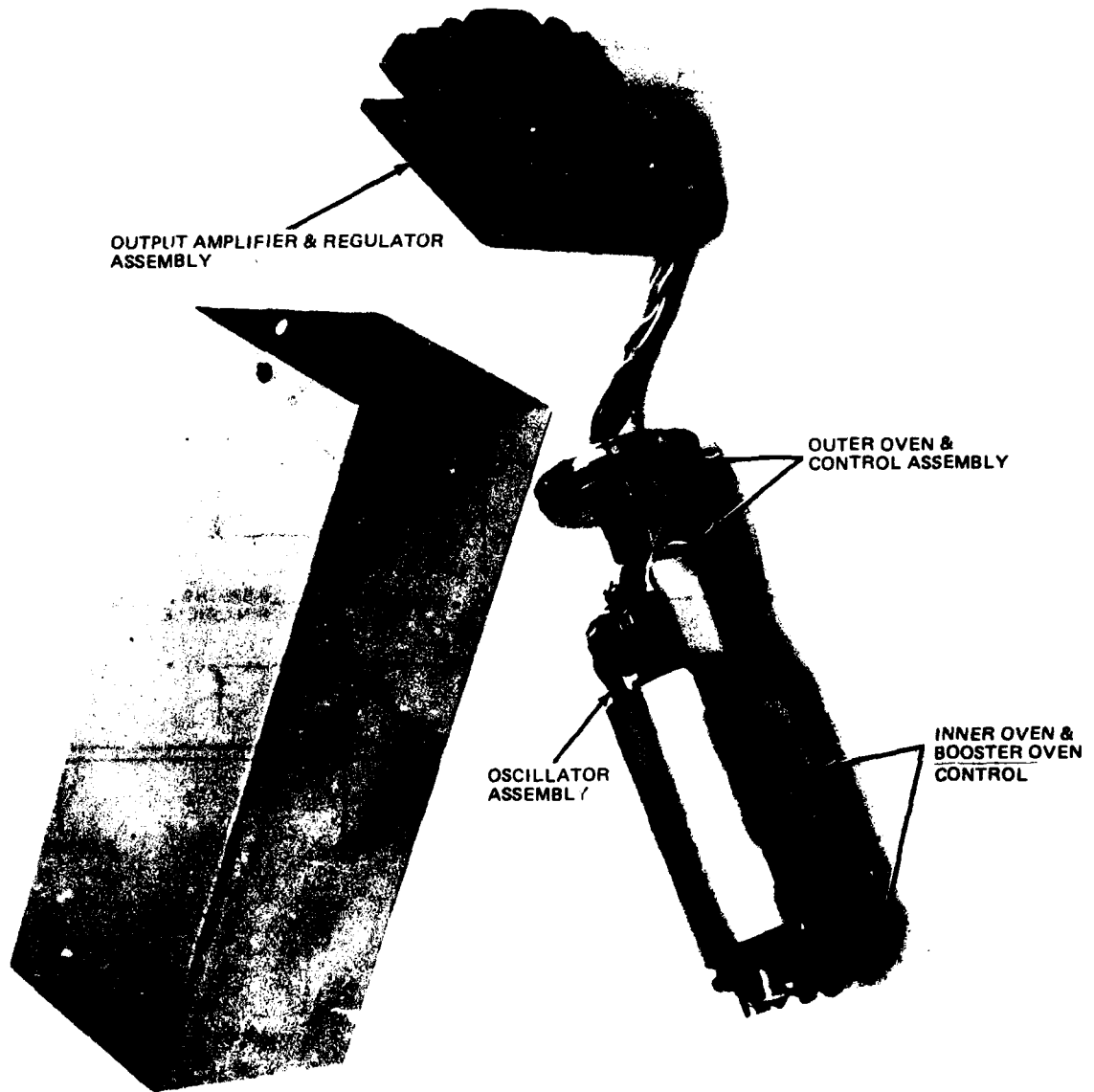

Figure 2. Mechanical Package of 5 MHz Oscillator

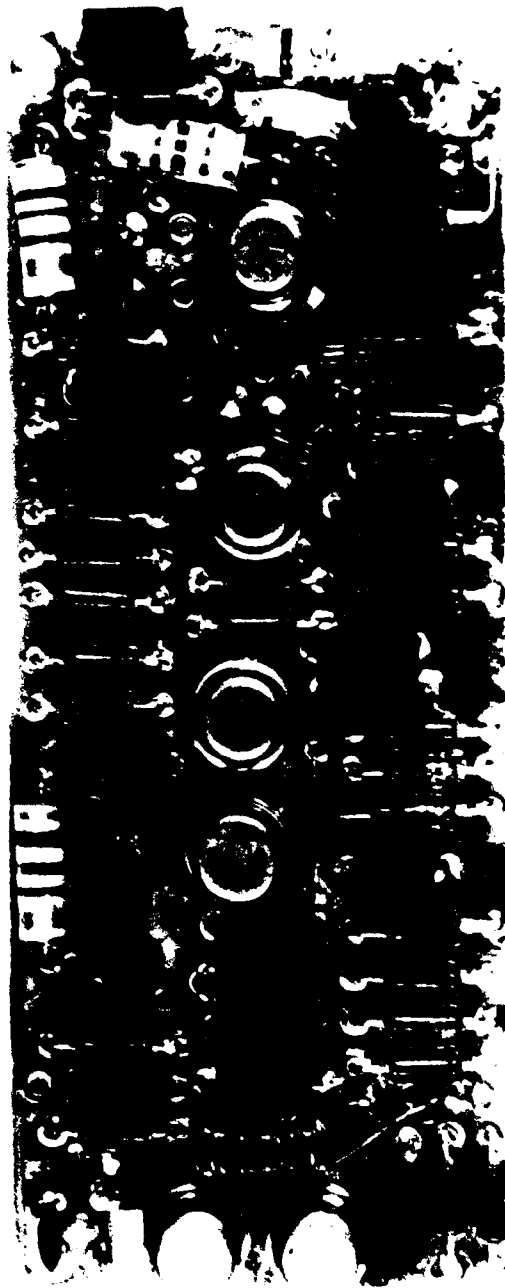
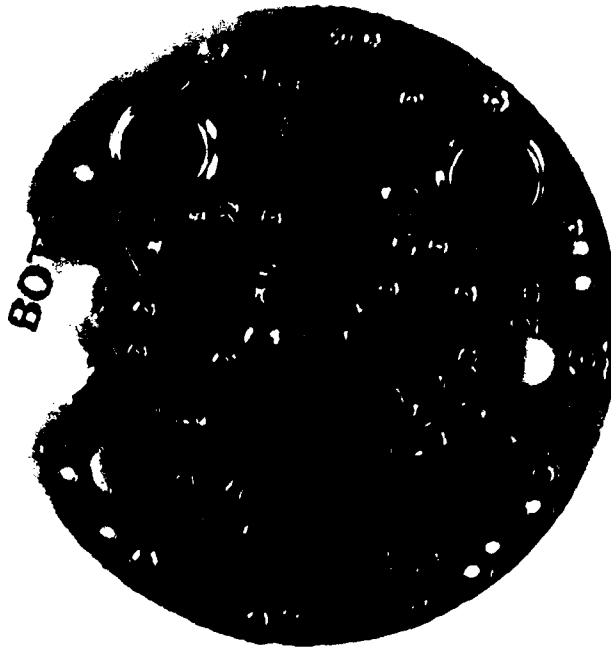

Figure 3. Oscillator PC Assembly



COMPONENT SIDE
(VIEW SHOWN LOOKING THRU PC BOARD)



SOLDER SIDE

Figure 4. Inner Oven PC Assembly

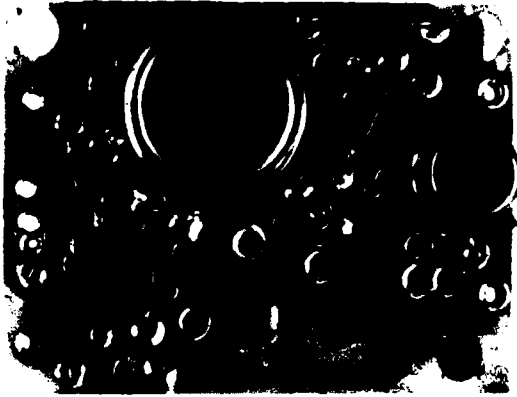

COMPONENT SIDE

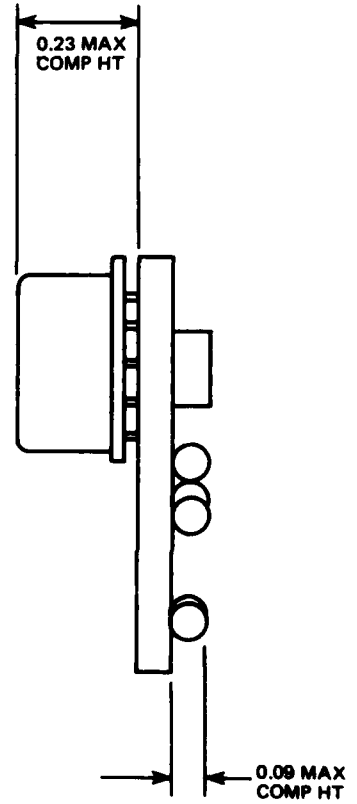

Figure 5. Outer Oven PC Assembly

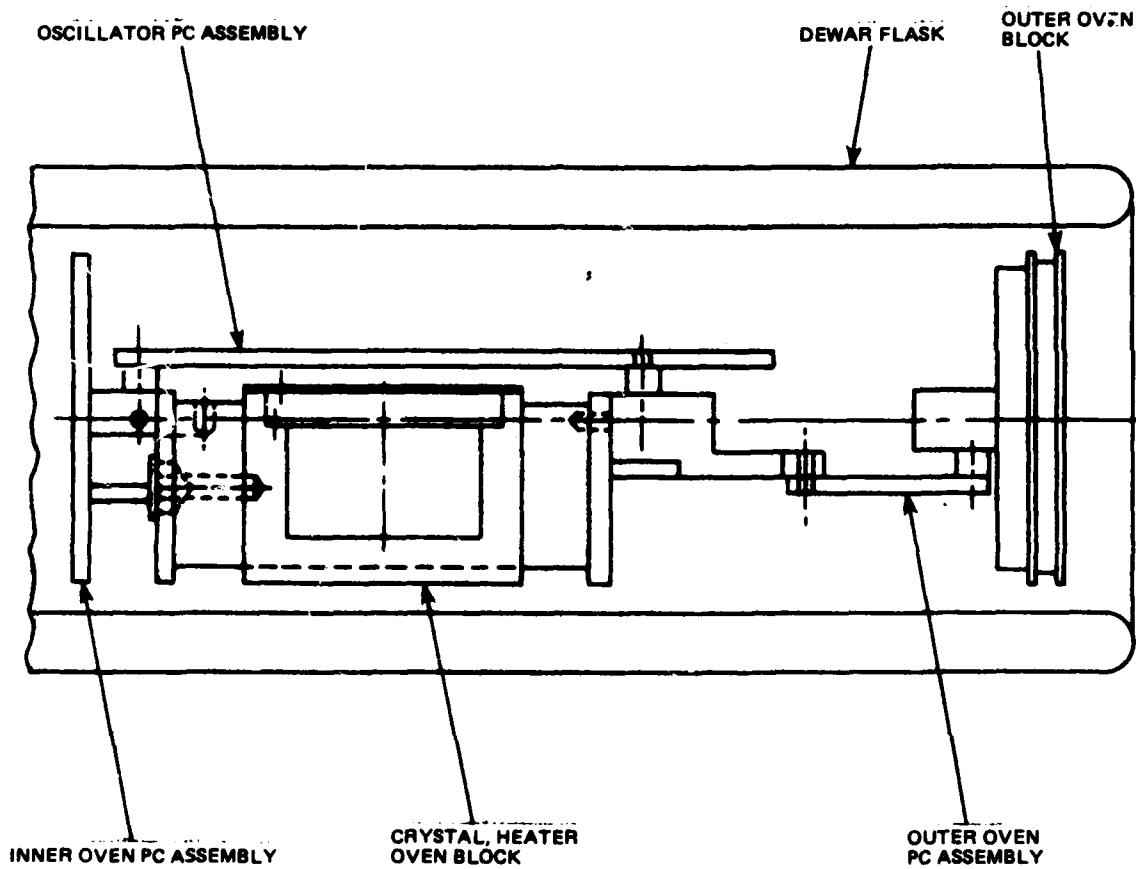

Figure 6. Internal Assembly

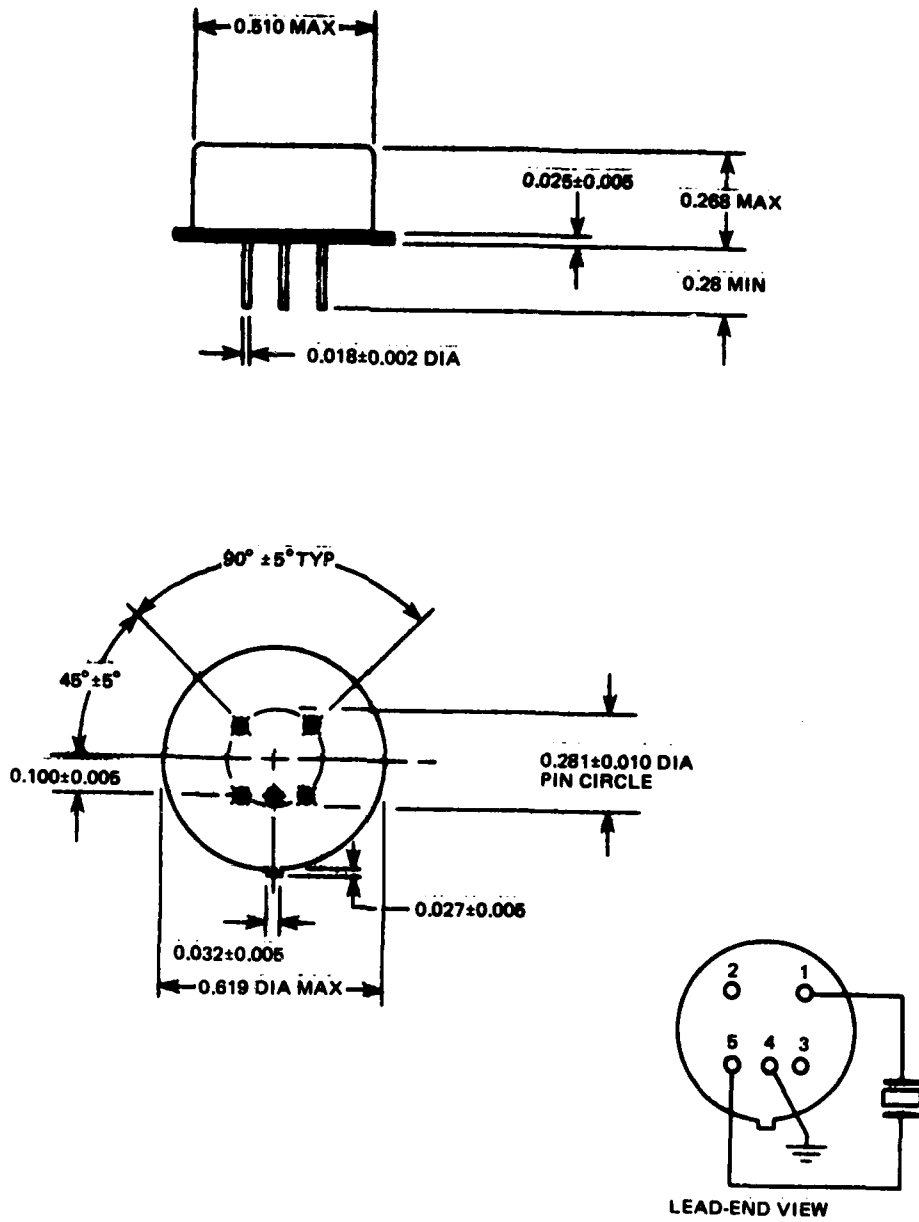

Figure 7. TO-8 Size Crystal Holder

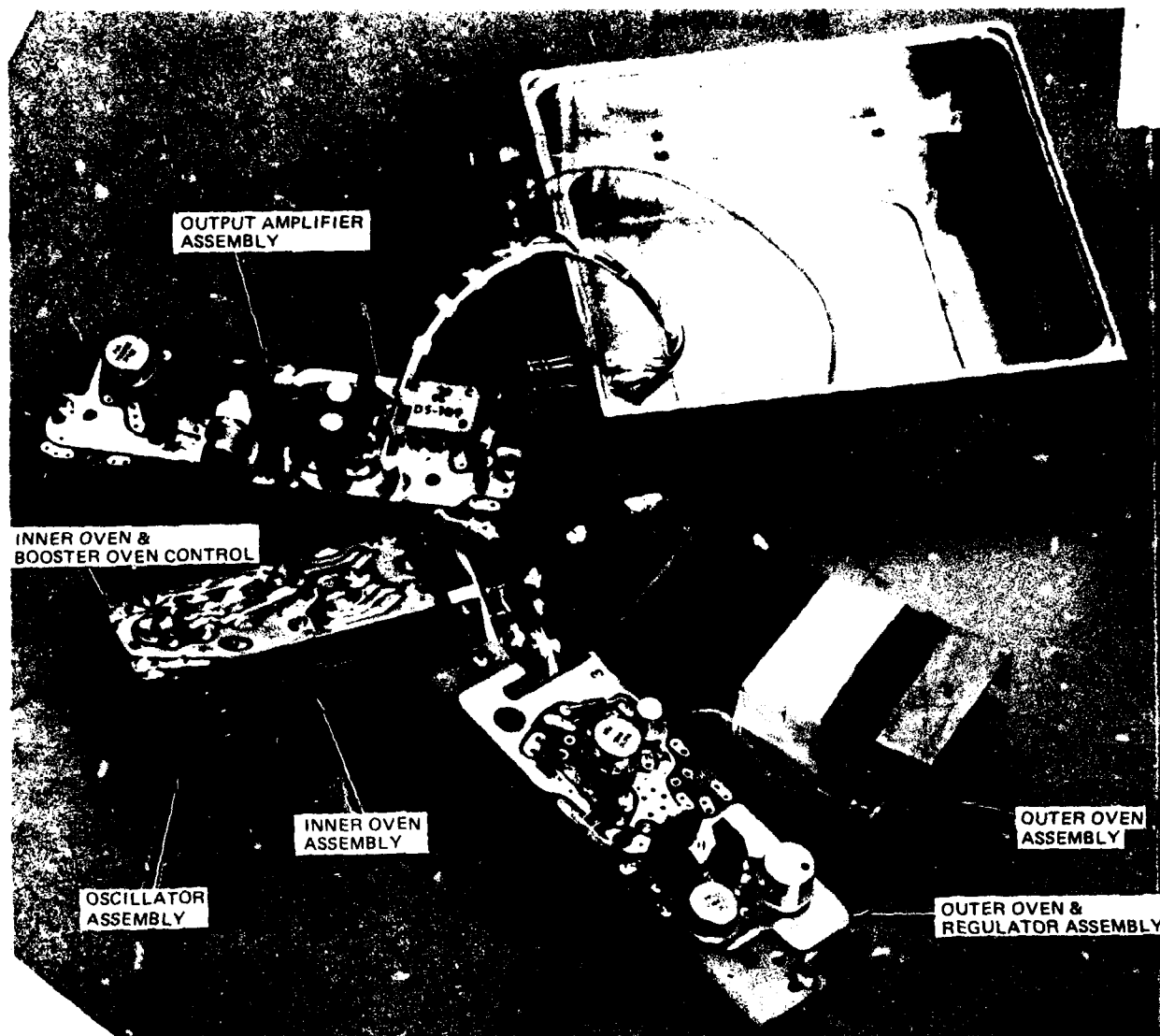

Figure 8. Mechanical Package of 10.05+ MHz Oscillator

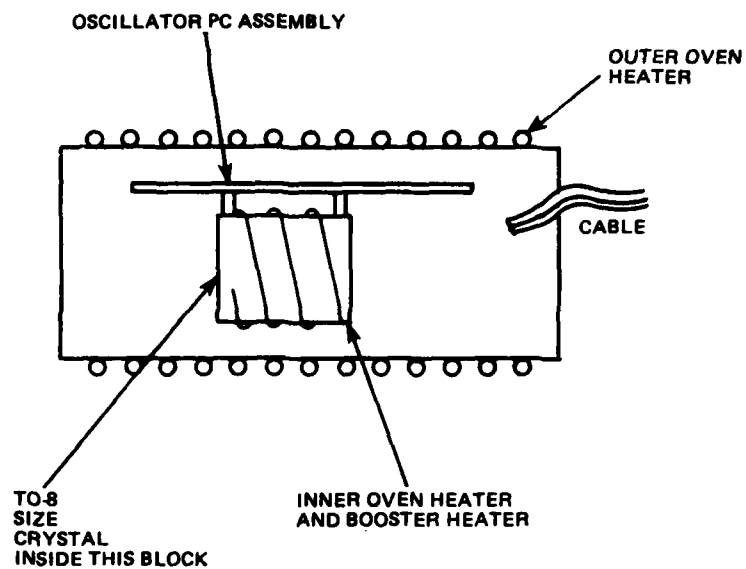

Figure 9. Oven Thermal Configuration of 10.05⁺ MHz Oscillator

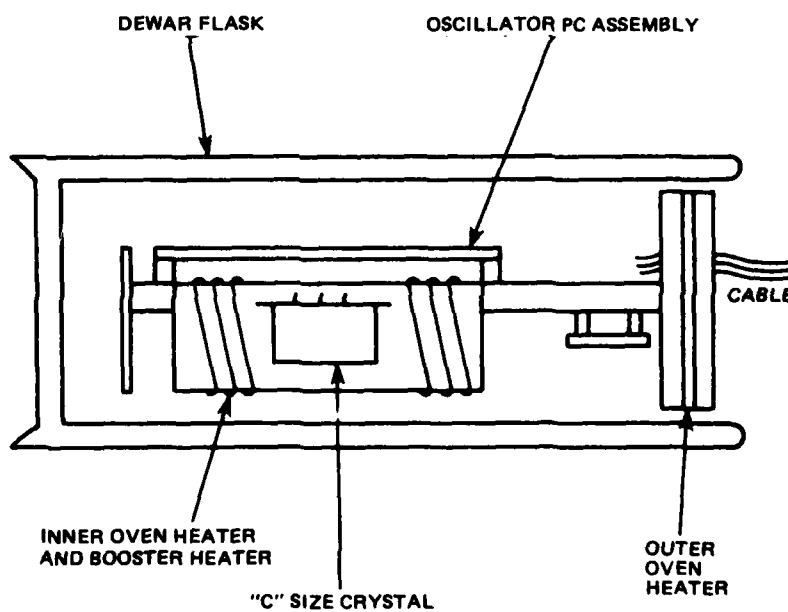

Figure 10. Oven Thermal Configuration of 5 MHz Oscillator

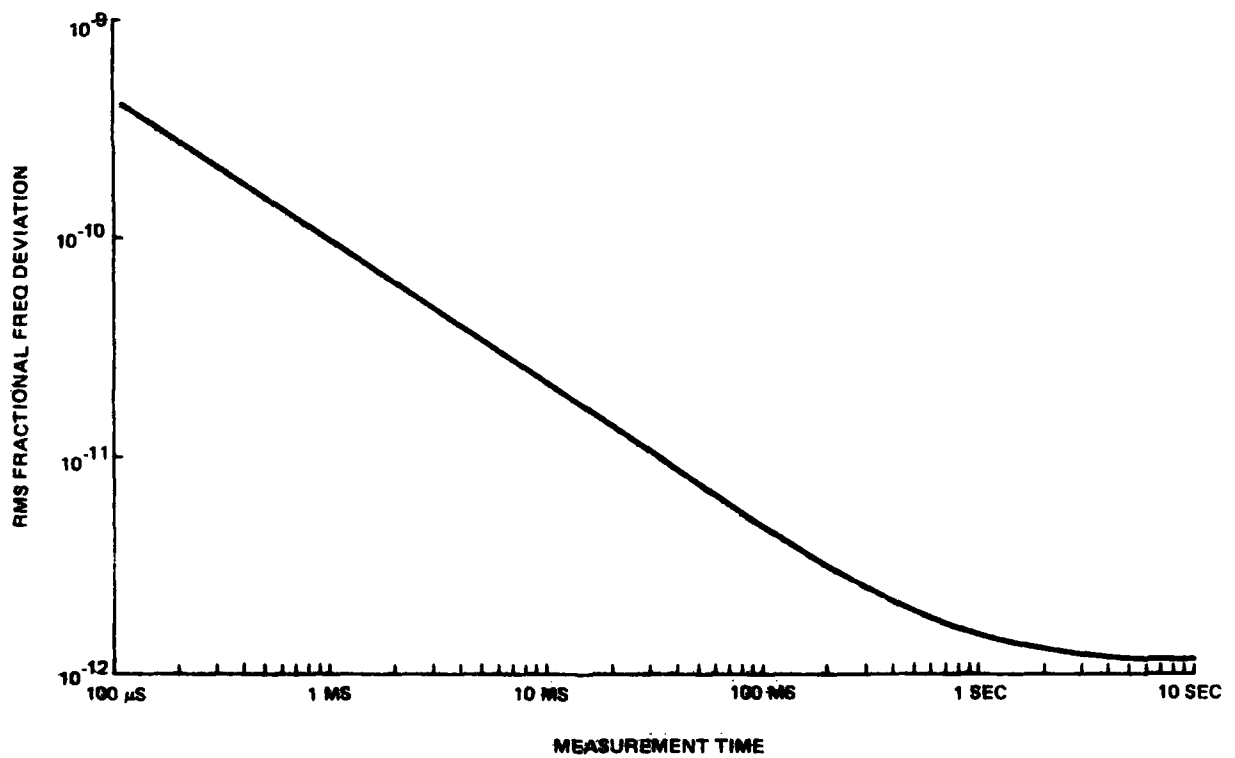

Figure 11. Short Term Stability of Oscillators S/N 001 & 003

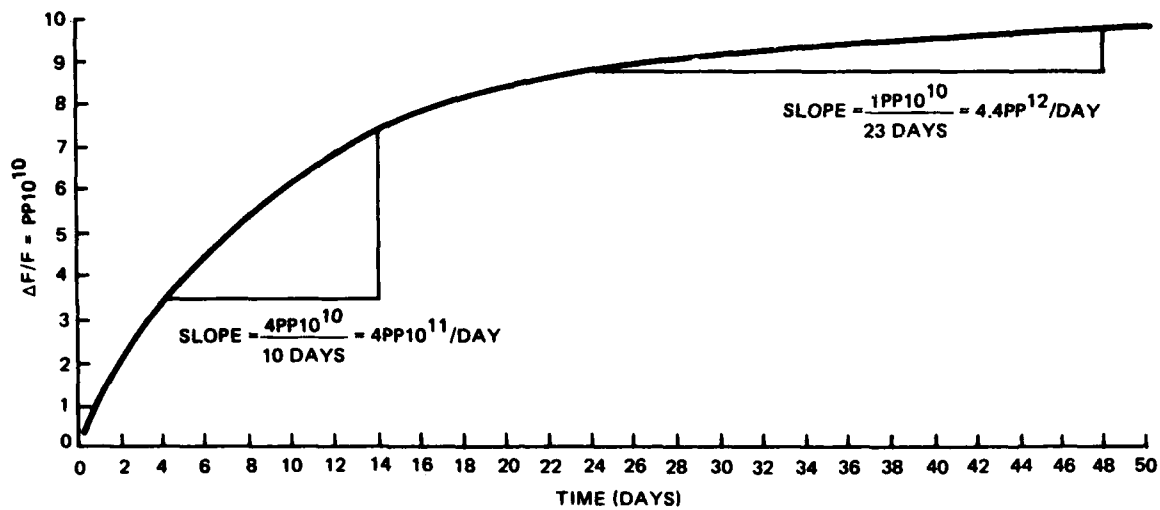

Figure 12. Long Term Stability of Oscillator S/N 001

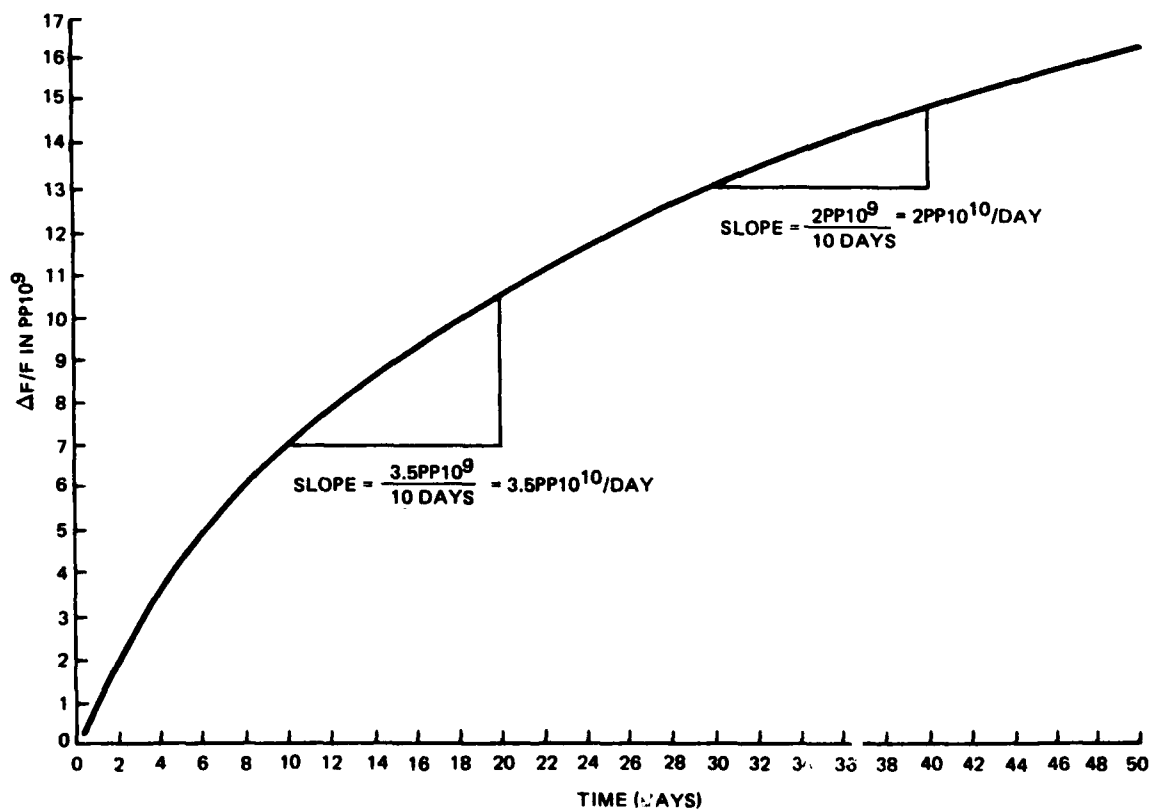

Figure 13. Long Term Stability of Oscillator S/N 002

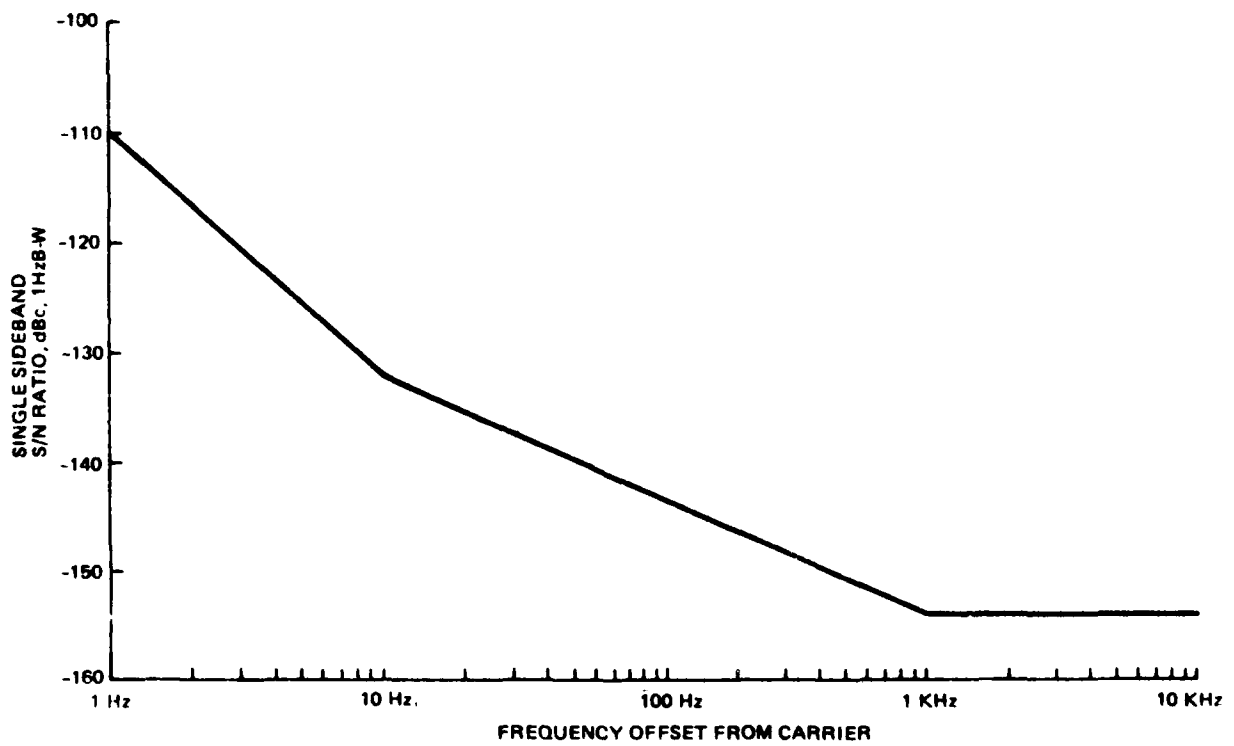

Figure 14. Phase Noise for Oscillator S/N 001 & 002

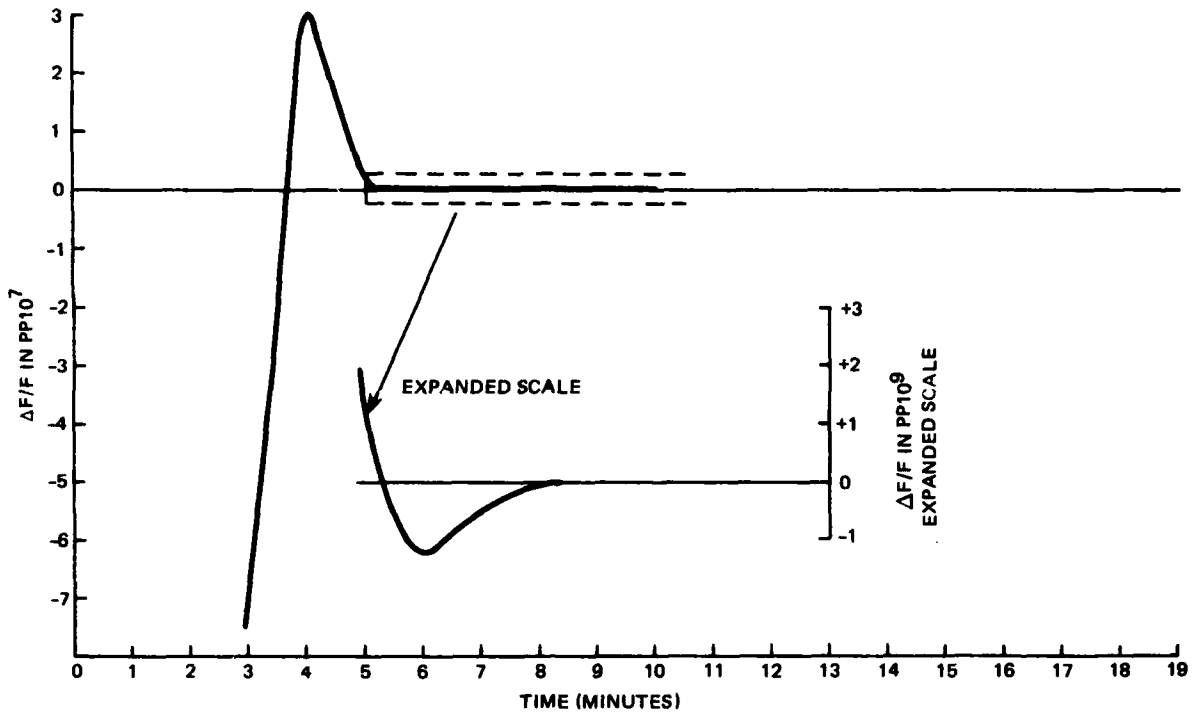

Figure 15. Warm-Up for Oscillator S/N 001

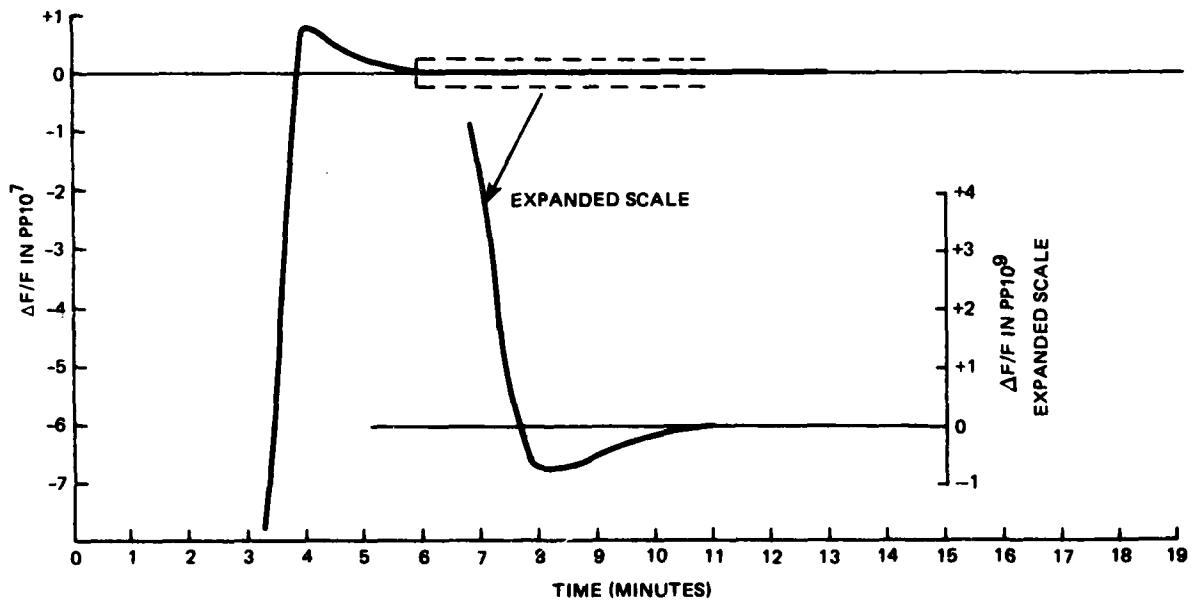

Figure 16. Warm-Up for Oscillator S/N 002

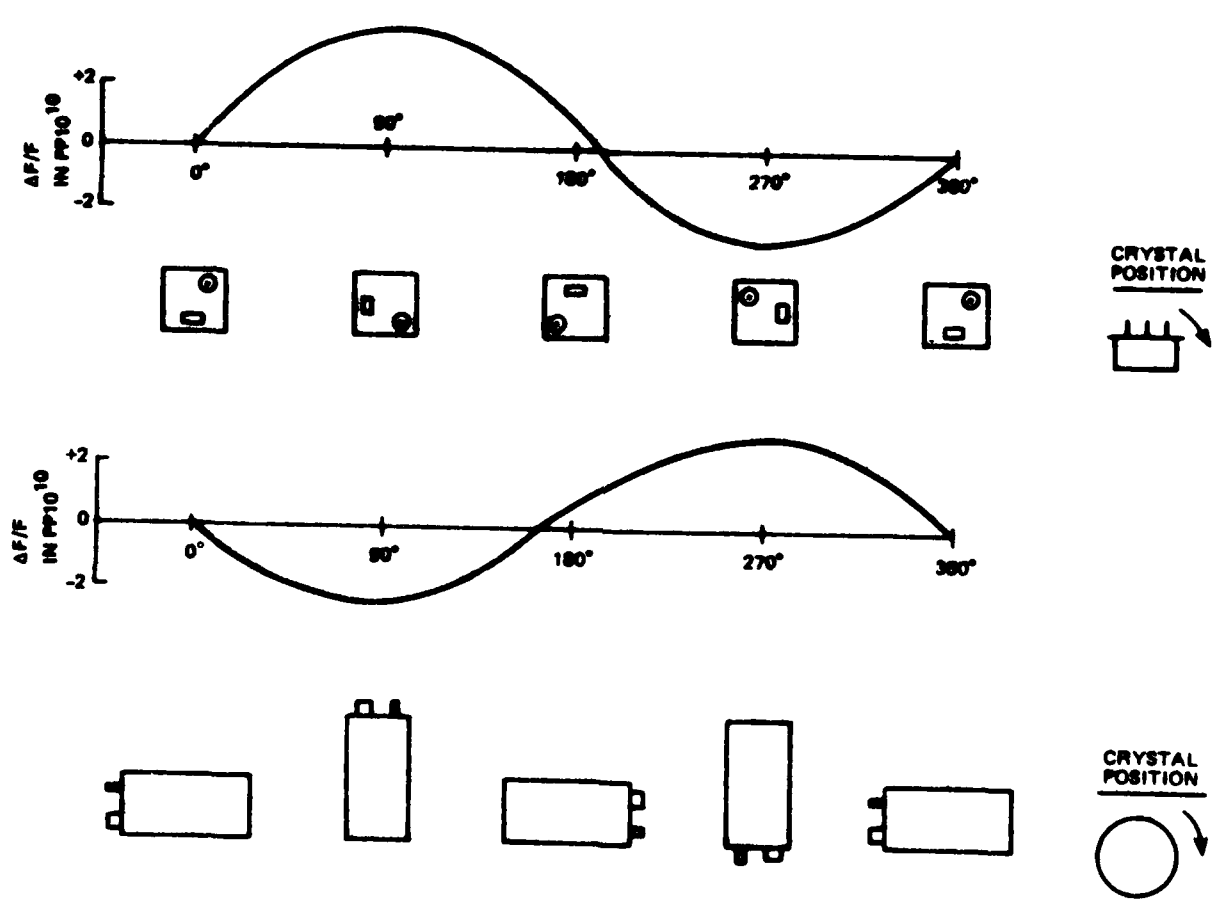

Figure 17. "g" Sensitivity for Oscillator S/N 001

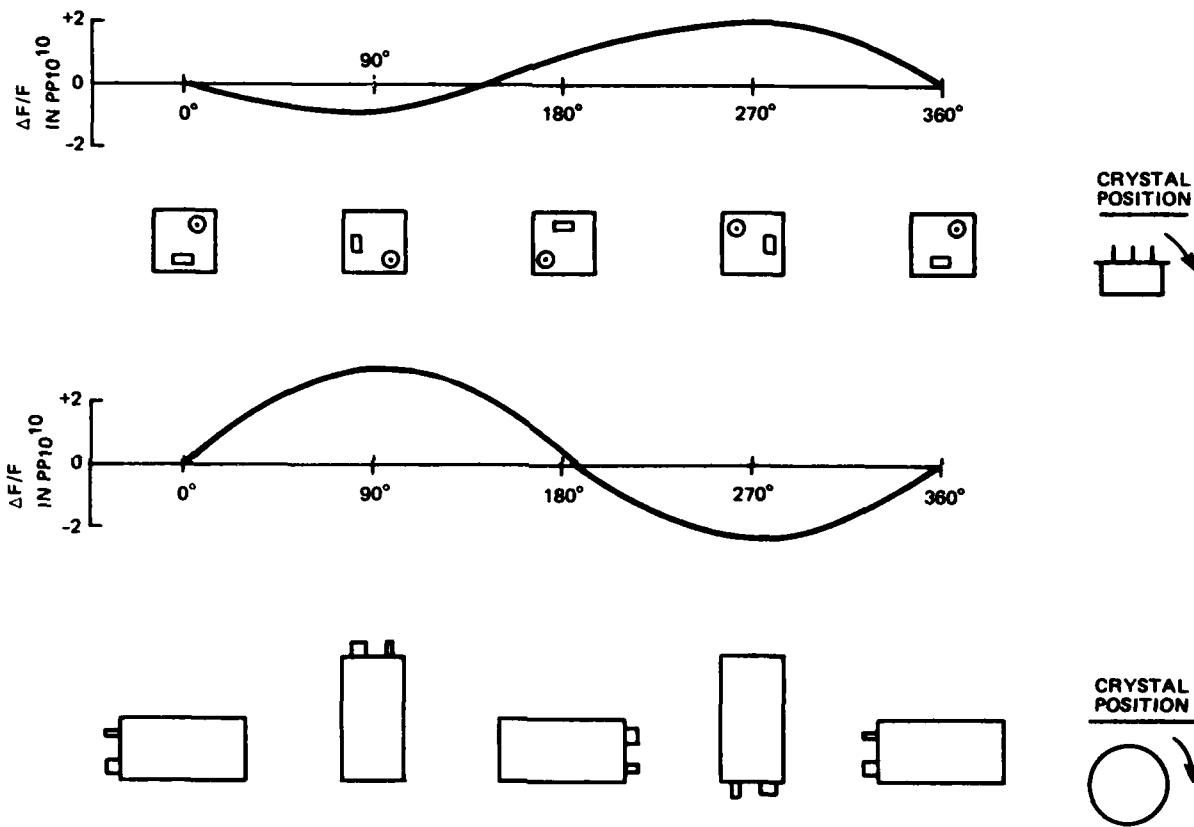

Figure 18. "g" Sensitivity for Oscillator S/N 002

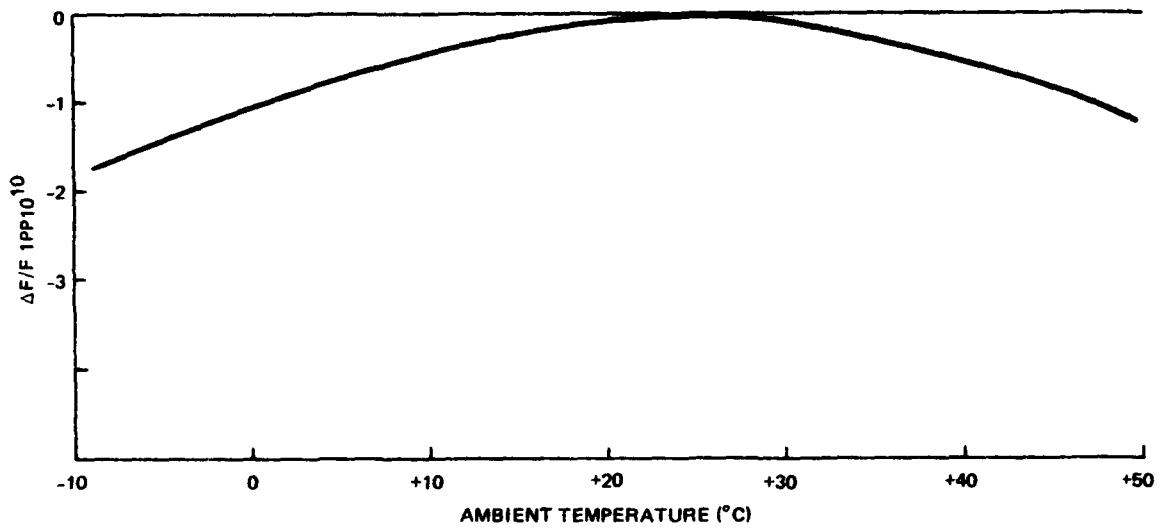

Figure 19. Frequency Vs. Temperature for Oscillator S/N 001 & 002

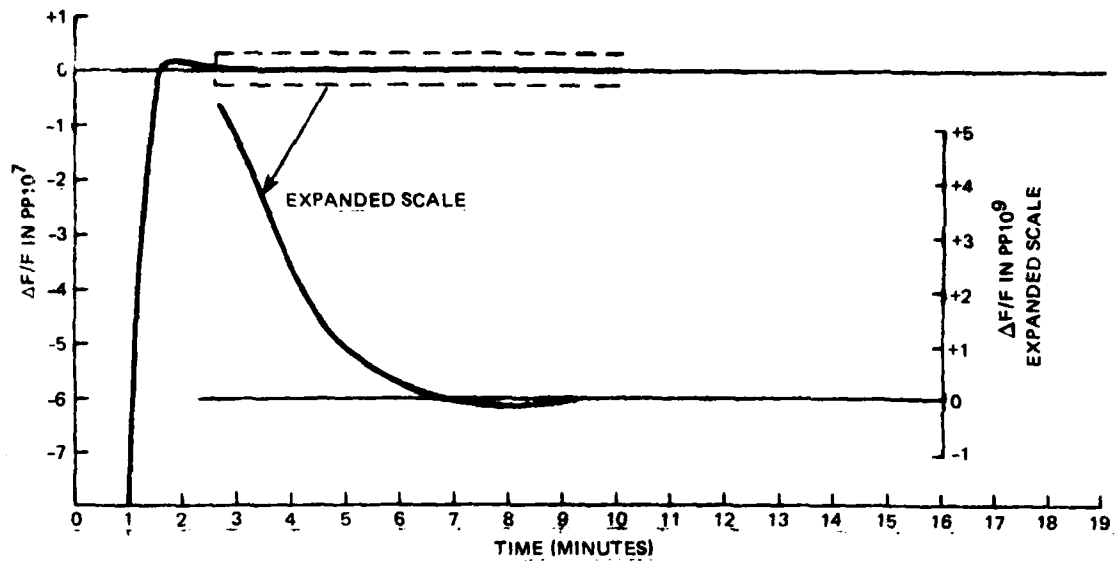

Figure 20. Warm-Up for Oscillator S/N 003

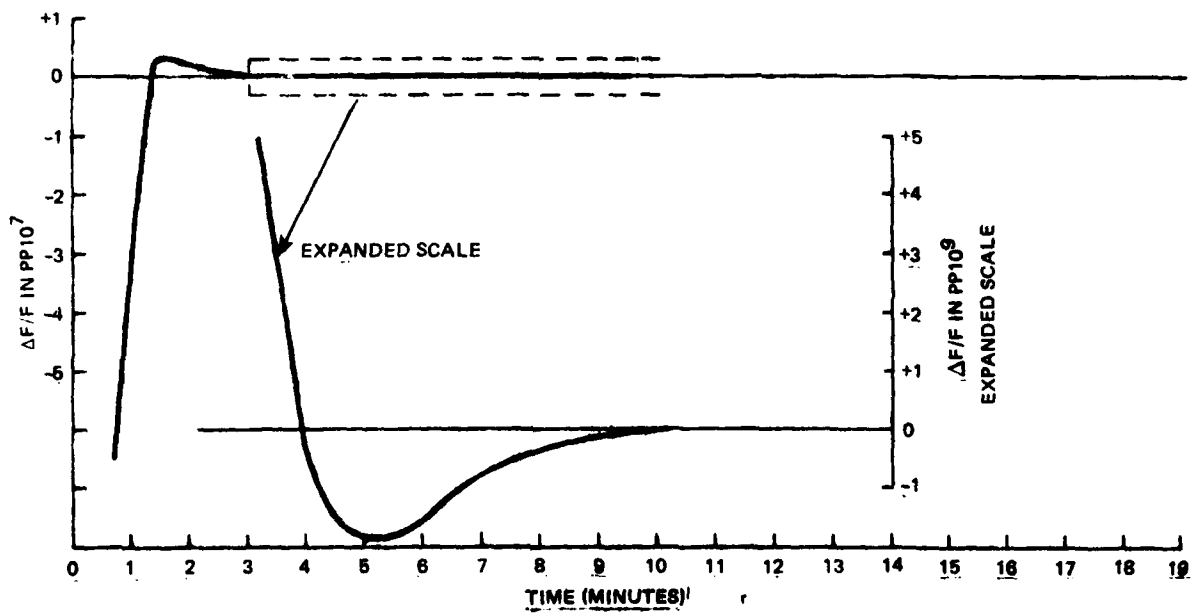

Figure 21. Warm-Up for Oscillator S/N 004

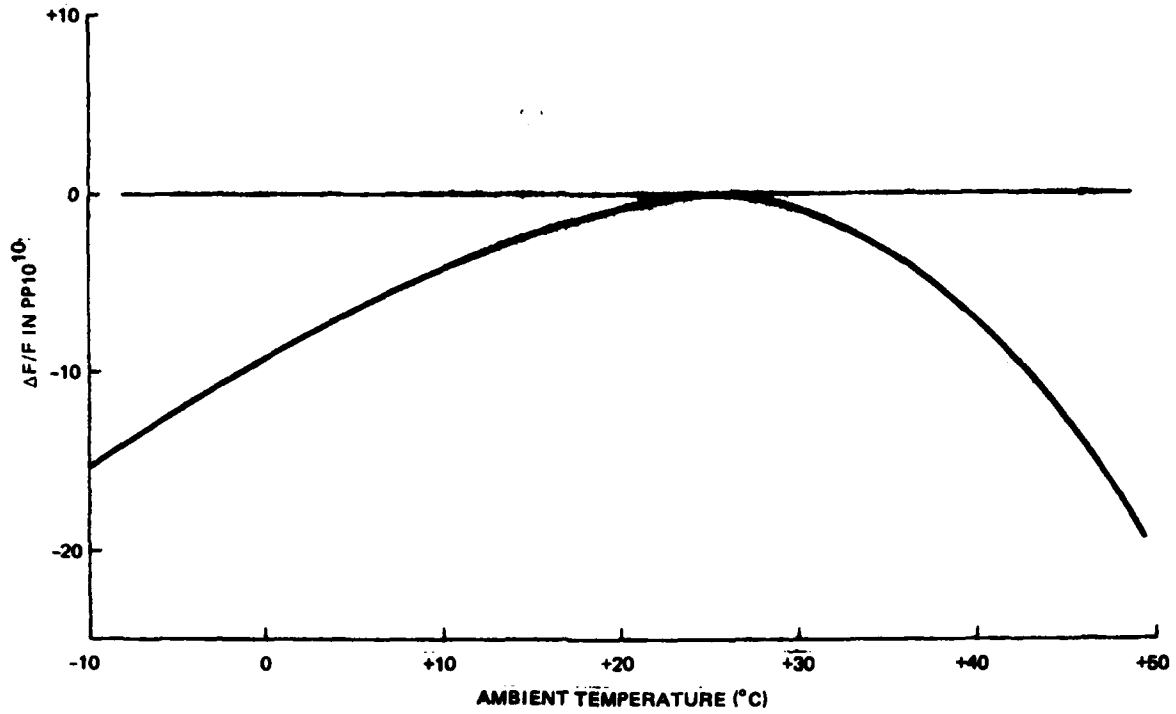

Figure 22. Frequency Vs. Temperature for Oscillator S/N 003

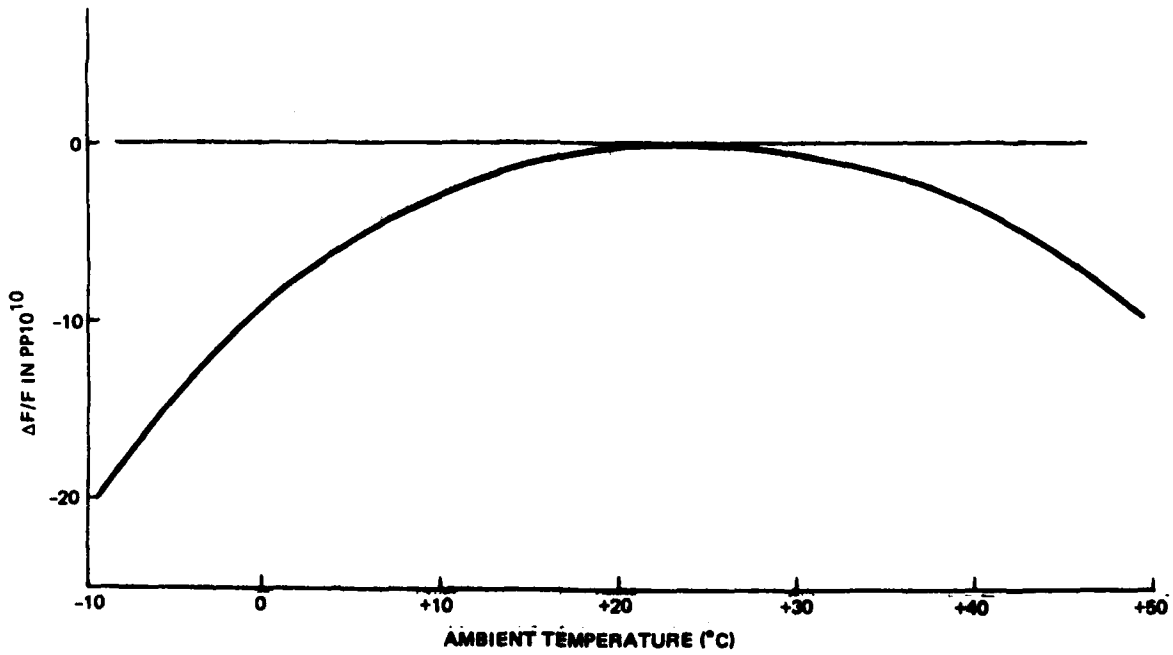

Figure 23. Frequency Vs. Temperature for Oscillator S/N 004

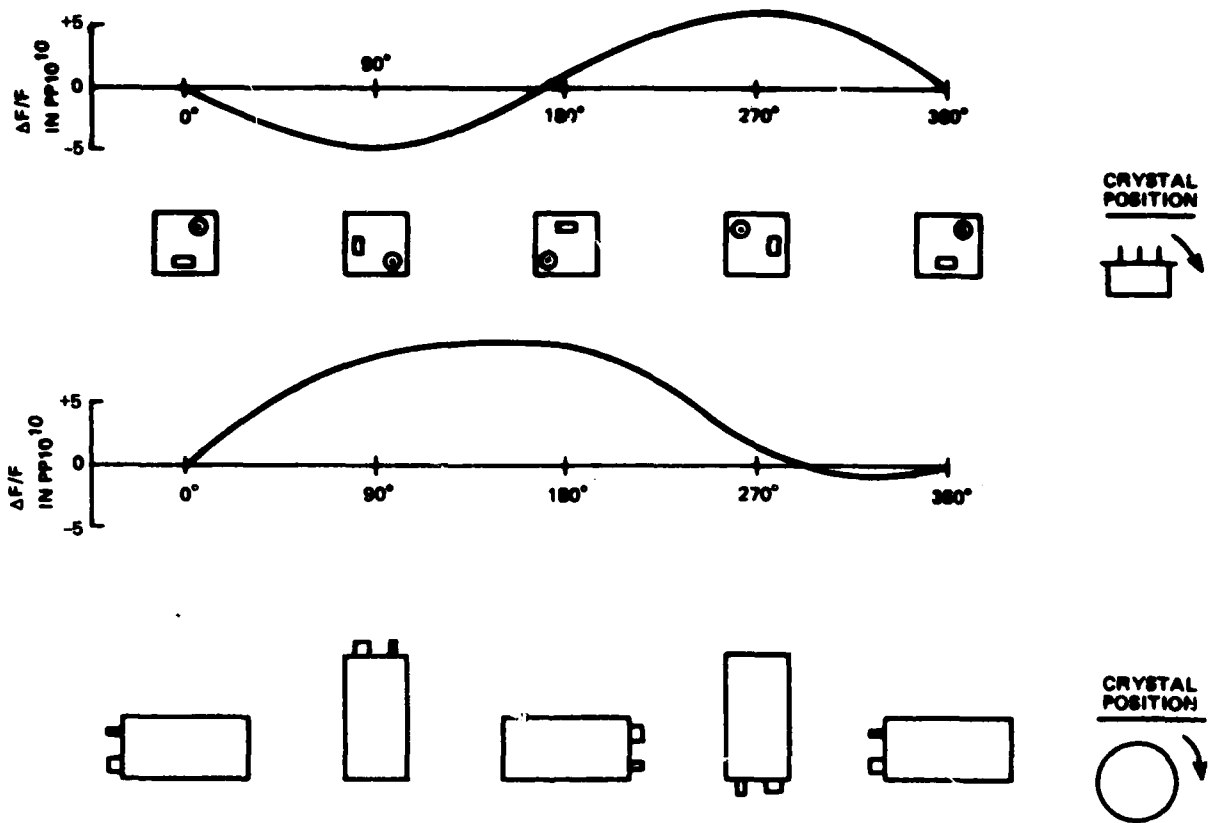

Figure 24. "g" Sensitivity for Oscillator S/N 003

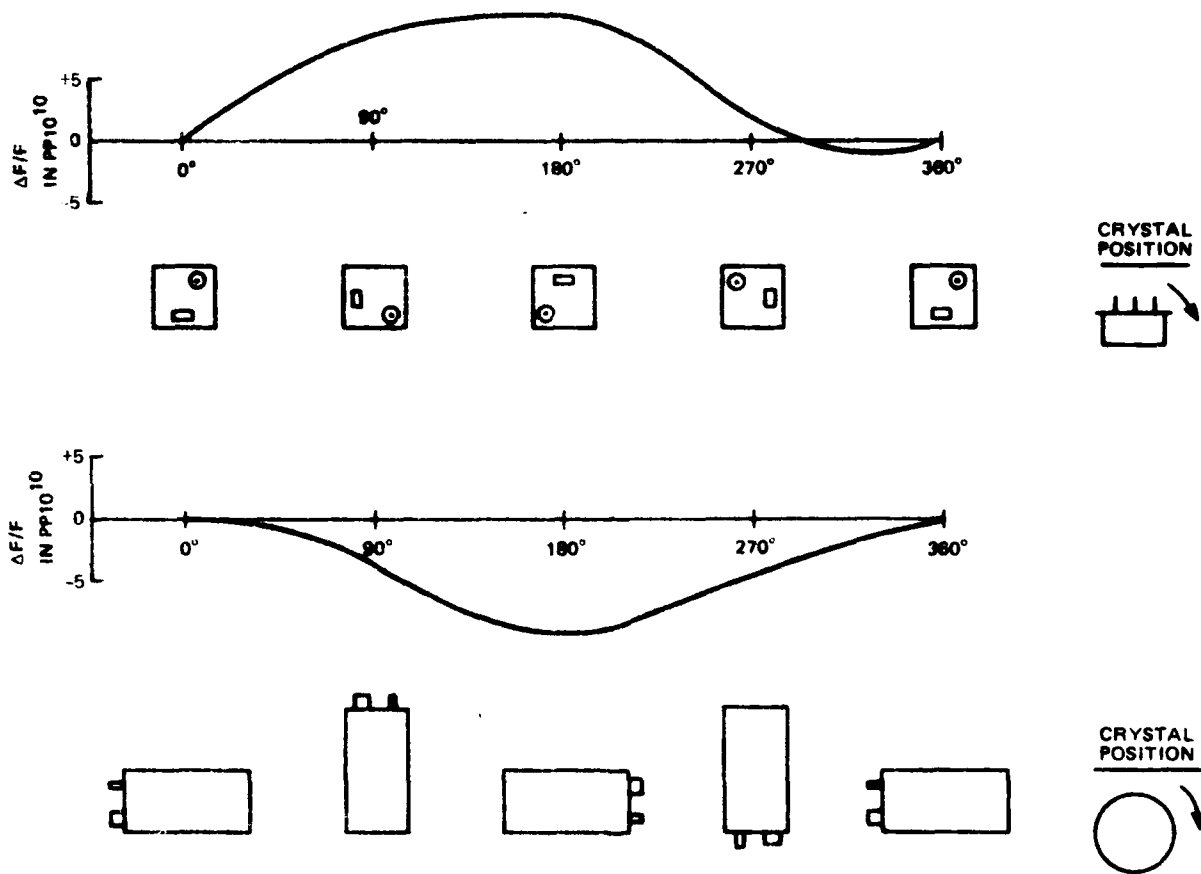

Figure 25. "g" Sensitivity for Oscillator S/N 004

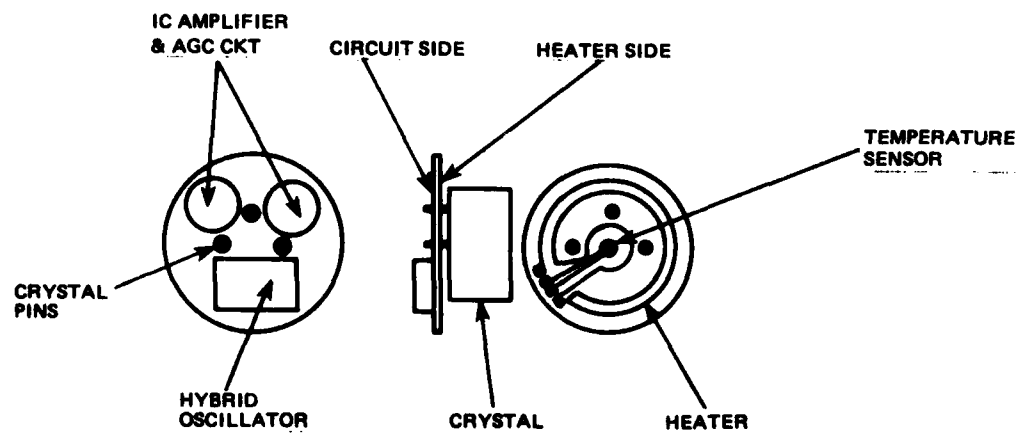
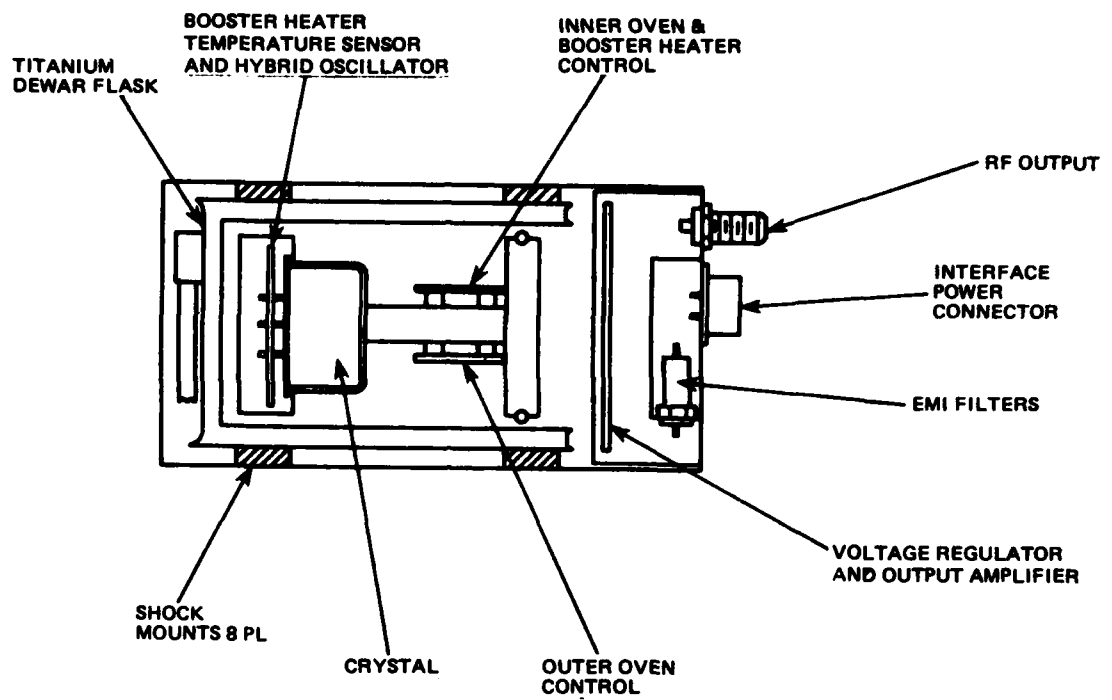
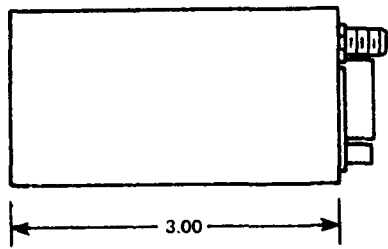
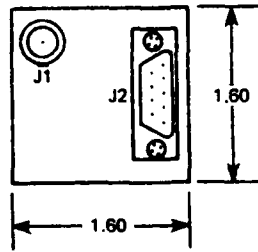

Figure 26. New OXO Internal Sketch



VOLUME = 7.68 CU IN
WEIGHT \cong 6

J1
RF OUTPUT



J2

PIN FUNCTION
 1 = +12 VDC
 2 = INNER OVEN MONITOR
 3 = OUTER OVEN MONITOR
 4 = BOOSTER OVEN MONITOR
 5 = DC RETURN
 6 = VCO RETURN
 7 = VCO INPUT
 8 = VCO REFERENCE VOLTAGE
 9 = SPARE

CHOICE OF MOUNTING
CONFIGURATIONS

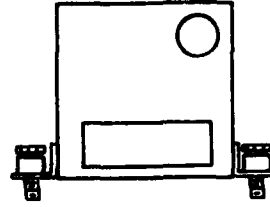

A

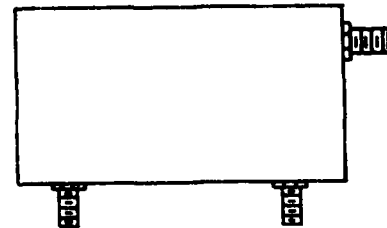

B

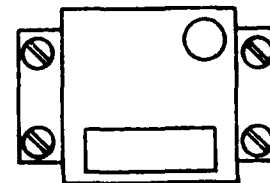

Figure 27. New OCXO Configuration

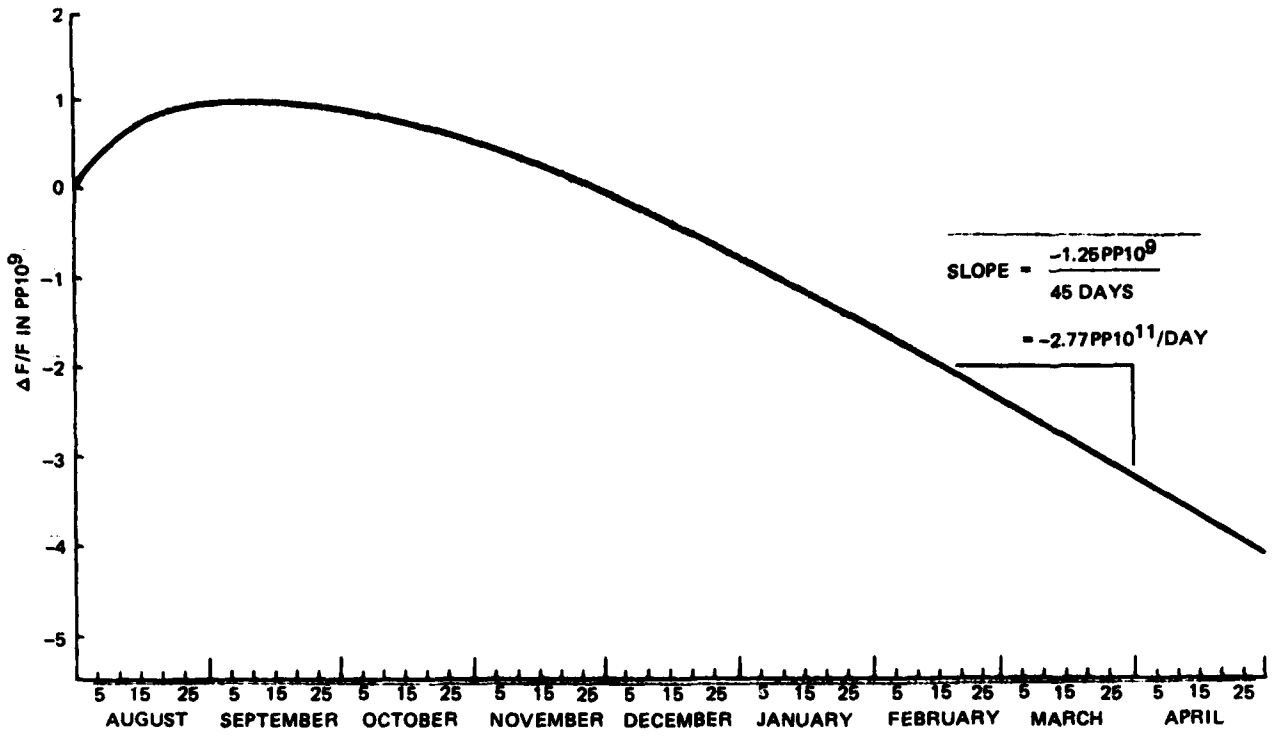

Figure 28. Long Term Stability of Oscillator S/N 001

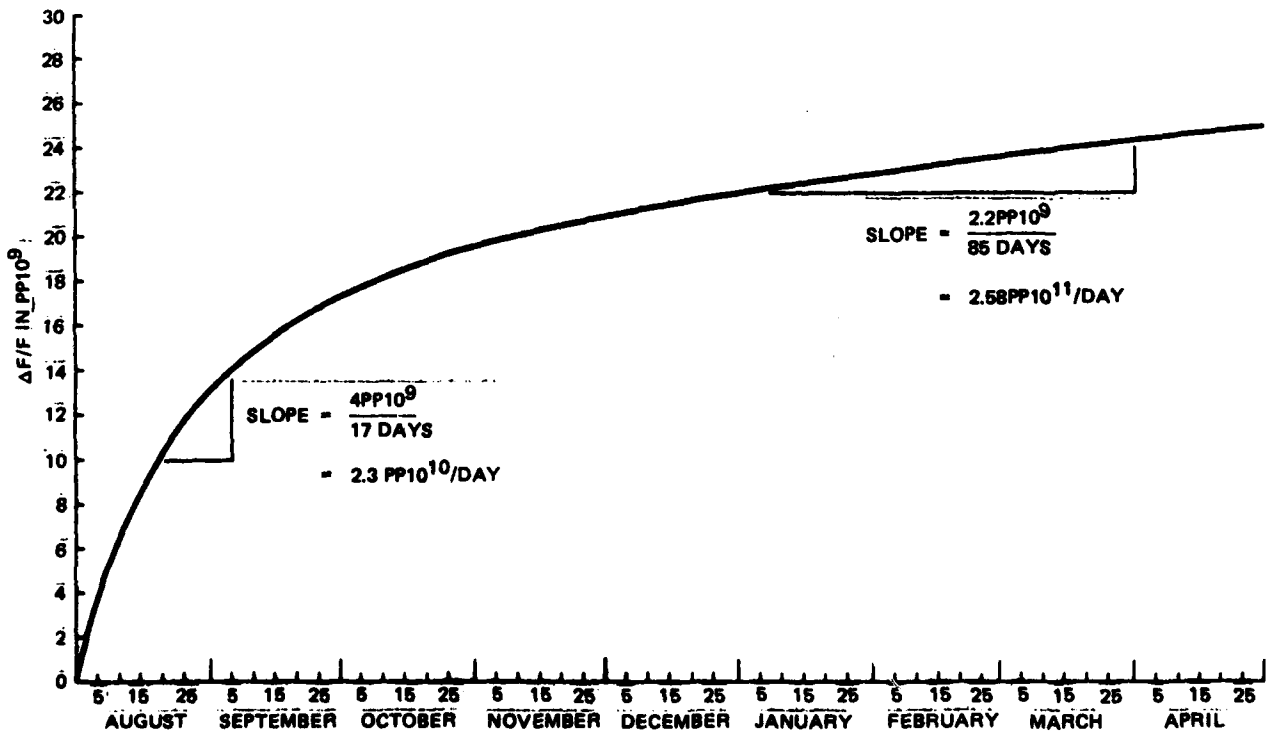

Figure 29. Long Term Stability of Oscillator S/N 002

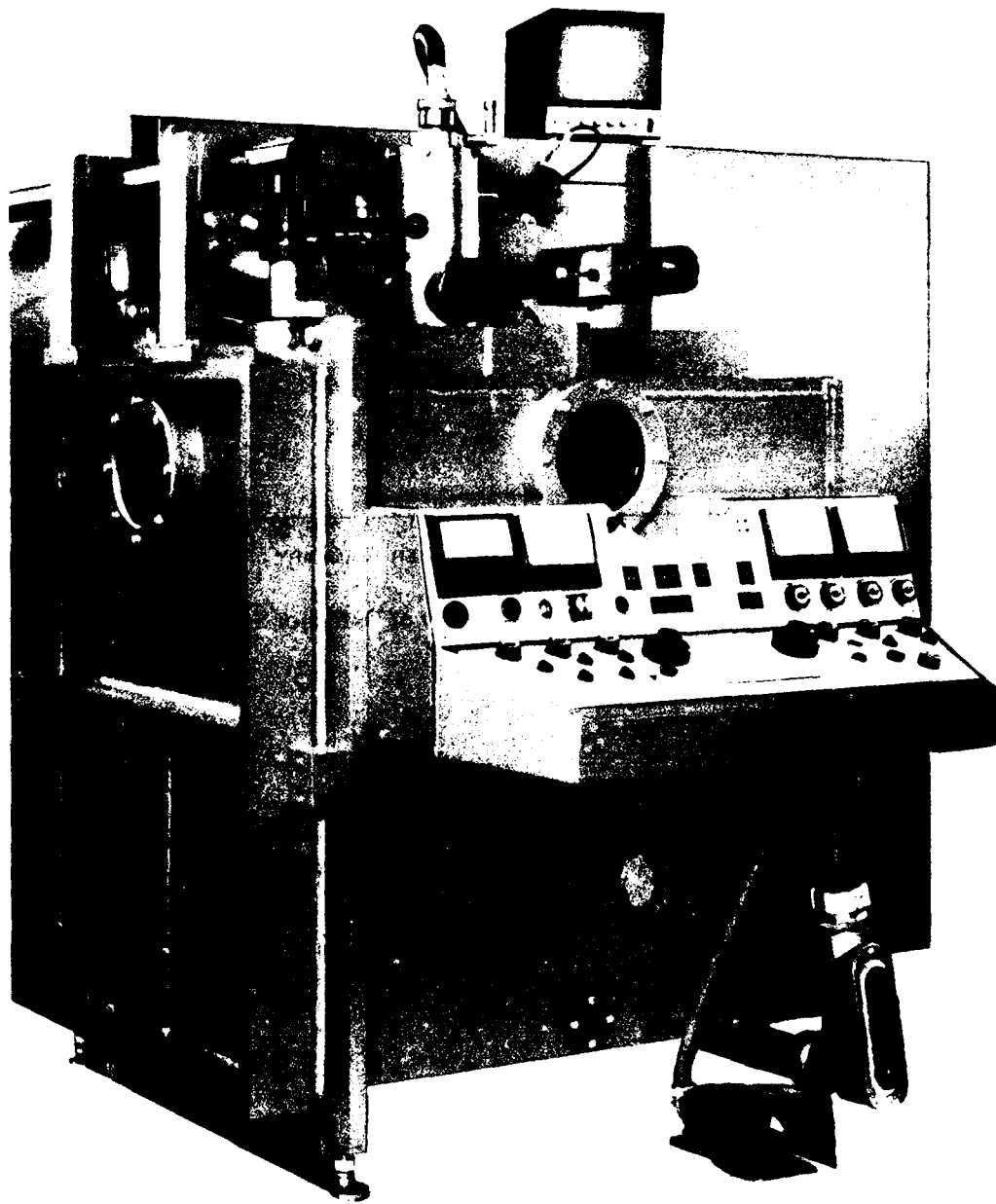

Figure 30. Electron Beam Welding Equipment

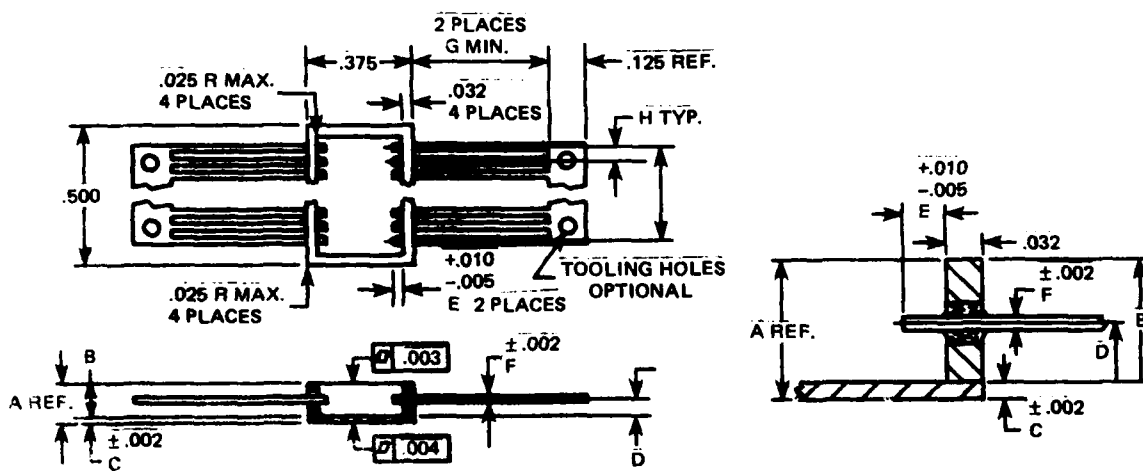

Figure 31. Crystal Enclosure, Physical Dimensions

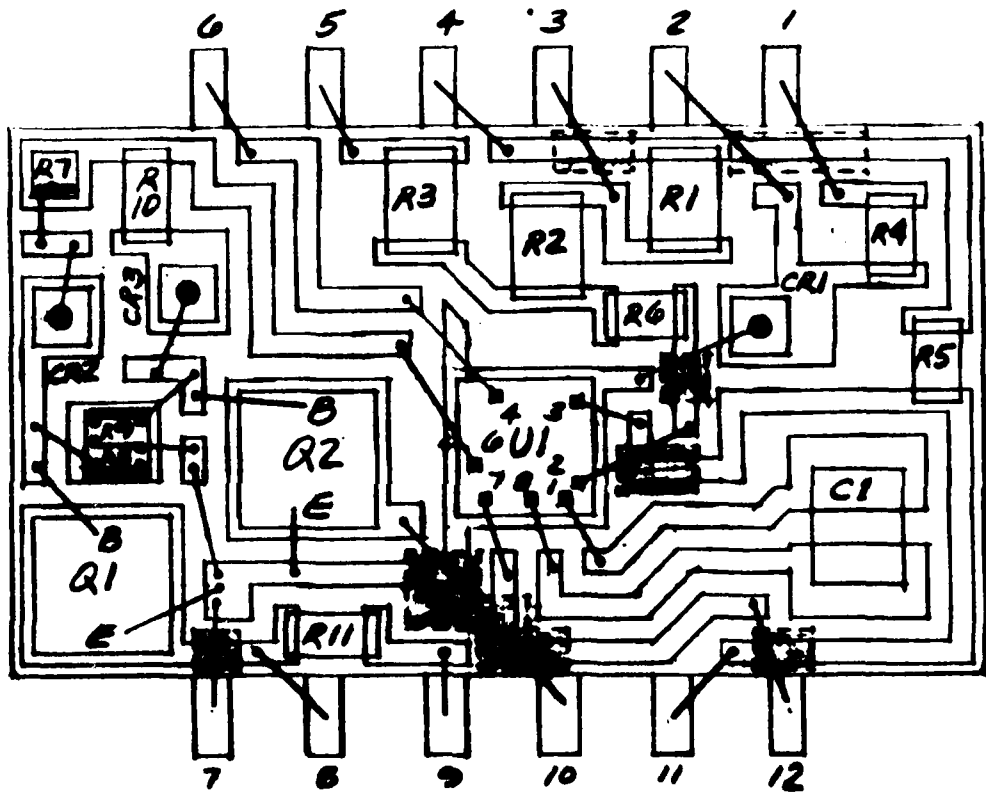

Figure 32. Hybrid Oven Flat-pack

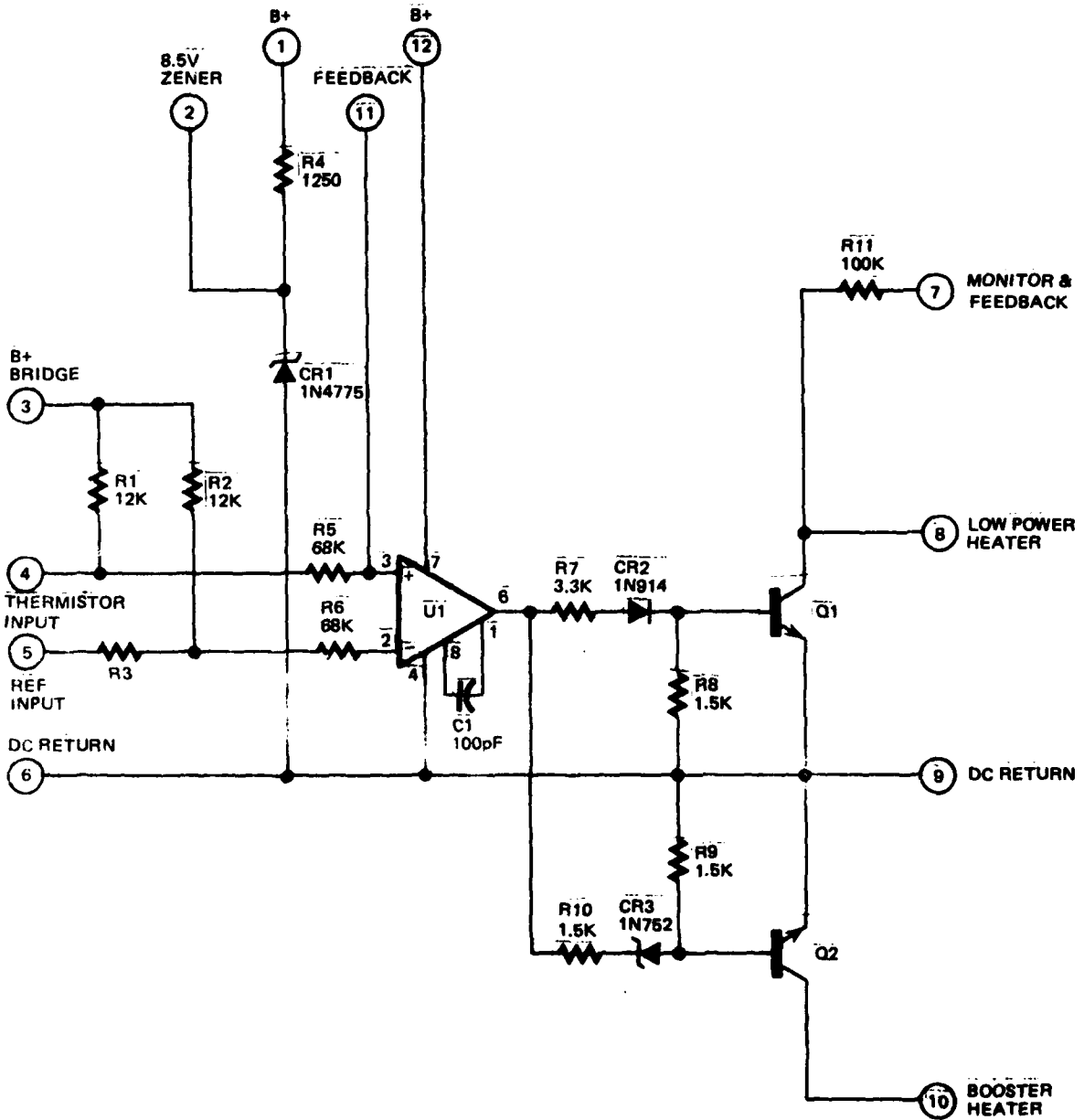
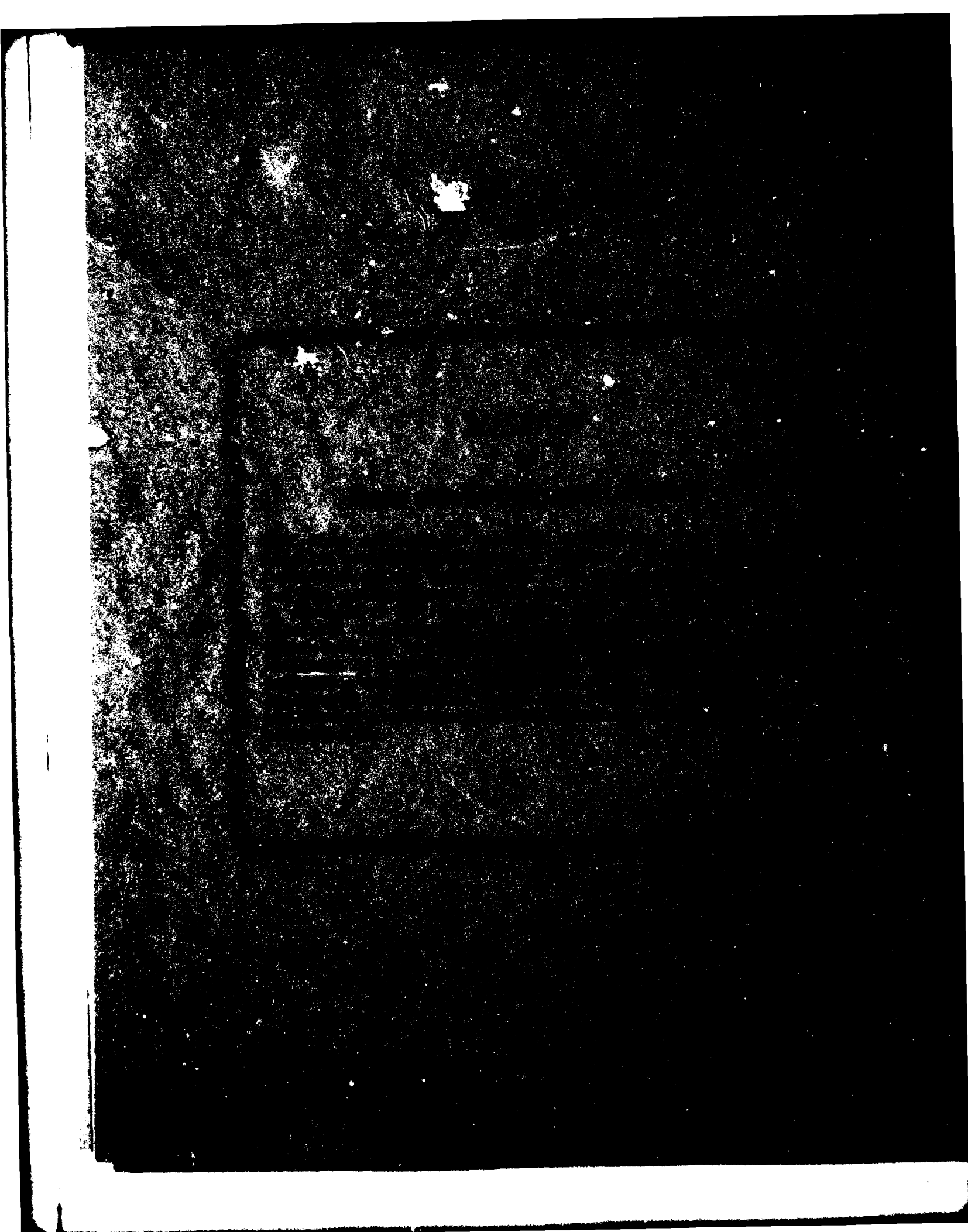

Figure 33. Hybrid Oven Flat-pack, Schematic Diagram



FILMEI
— 8