

USAAVRADCOM-TR-82-D-9

AD A118827 |



12

**SLACK WIRE STRIKE PROTECTION CONCEPTS**

BELL HELICOPTER TEXTRON, INC.  
P. O. Box 482  
Fort Worth, Tex. 76101

July 1982

Final Report for Period September 1981 - May 1982

Approved for public release;  
distribution unlimited.

DTIC  
SELECTED  
SEP 0 2 1982  
E

Prepared for  
APPLIED TECHNOLOGY LABORATORY  
U. S. ARMY RESEARCH AND TECHNOLOGY LABORATORIES (AVRADCOM)  
Fort Rysstis, Va. 23604

DTIC FILE COPY

82 01 15 016

## APPLIED TECHNOLOGY LABORATORY POSITION STATEMENT

This report is considered to define effective concepts for slack wire strike protection that have retrofit potential for existing Army helicopters. Prior to implementation of any of these concepts, full-scale testing and cost effectiveness analyses are required. Results of this contract will be considered in formulation of future programs and aircraft design requirements.

LeRoy T. Burrows of the Aeronautical Systems Division served as project engineer for this effort.

### DISCLAIMERS

The findings in this report are not to be construed as an official Department of the Army position unless so designated by other authorized documents.

When Government drawings, specifications, or other data are used for any purpose other than in connection with a definitely related Government procurement operation, the United States Government thereby incurs no responsibility nor any obligation whatsoever; and the fact that the Government may have formulated, furnished, or in any way supplied the said drawings, specifications, or other data is not to be regarded by implication or otherwise as in any manner licensing the holder or any other person or corporation, or conveying any rights or permission, to manufacture, use, or sell any patented invention that may in any way be related thereto.

Trade names cited in this report do not constitute an official endorsement or approval of the use of such commercial hardware or software.

### DISPOSITION INSTRUCTIONS

Destroy this report when no longer needed. Do not return it to the originator.

Unclassified

SECURITY CLASSIFICATION OF THIS PAGE (When Data Entered)

REPORT DOCUMENTATION PAGE		READ INSTRUCTIONS BEFORE COMPLETING FORM
1. REPORT NUMBER USAAVRADCOM TR-82-D-9	2. GOVT ACCESSION NO.	3. RECIPIENT'S CATALOG NUMBER
4. TITLE (and Subtitle) SLACK WIRE STRIKE PROTECTION CONCEPTS	5. TYPE OF REPORT & PERIOD COVERED Final Report September 1981-May 1982	
	6. PERFORMING ORG. REPORT NUMBER	
7. AUTHOR(s)	8. CONTRACT OR GRANT NUMBER(s) DAAK51-81-C-0034 DAAK	
9. PERFORMING ORGANIZATION NAME AND ADDRESS Bell Helicopter Textron, Incorporated P. O. Box 482 Fort Worth, Texas 76101	10. PROGRAM ELEMENT, PROJECT, TASK AREA & WORK UNIT NUMBERS 62209A 1L162209AH76 H76E 032	
11. CONTROLLING OFFICE NAME AND ADDRESS Applied Technology Laboratory, US Army Re- search & Technology Laboratories (AVRADCOM) Fort Eustis, Virginia 23604	12. REPORT DATE July 1982	
14. MONITORING AGENCY NAME & ADDRESS (if different from Controlling Office)	13. NUMBER OF PAGES 72	
	15. SECURITY CLASS. (of this report) Unclassified	
16. DISTRIBUTION STATEMENT (of this Report) Approved for public release; distribution unlimited.		
17. DISTRIBUTION STATEMENT (of the abstract entered in Block 20, if different from Report)		
18. SUPPLEMENTARY NOTES		
19. KEY WORDS (Continue on reverse side if necessary and identify by block number) Helicopter Tail Rotor Wire Strike Support Testing Slack Wire Fairings Rotating Controls Cutters Main Rotor Trade-off Study		
20. ABSTRACT (Continue on reverse side if necessary and identify by block number) A design study has been conducted to establish slack wire strike protection concepts. The objective of the study was to define and investigate design concepts that could prevent helicopter mishaps caused by main and tail rotor controls entanglement with a slack wire. The study helicopter was an OH-58A equipped with a taut wire strike protection system (WSPS).		

DD FORM 1473 EDITION OF 1 NOV 65 IS OBSOLETE

Unclassified

SECURITY CLASSIFICATION OF THIS PAGE (When Data Entered)

Unclassified

SECURITY CLASSIFICATION OF THIS PAGE(When Data Entered)

Block 20. Abstract - continued.

Eight main rotor and five tail rotor protection concepts were developed to the extent that their individual characteristics could be determined for use in a trade-off evaluation.

Two of the more promising main rotor concepts were evaluated during a whirl test. It was demonstrated in the test that both concepts were feasible and very effective in protecting the rotating controls from entanglement. From the results of the trade-off evaluation and testing, four main rotor and four tail rotor concepts were recommended for further development.

Accession For	
NTIS CRA&I	<input checked="" type="checkbox"/>
DTIC TAB	<input type="checkbox"/>
Unannounced	<input type="checkbox"/>
Justification	
By _____	
Distribution/	
Availability Codes	
Avail and/or	
Dist	Special
A	



1  
B

Unclassified

SECURITY CLASSIFICATION OF THIS PAGE(When Data Entered)

TABLE OF CONTENTS

	<u>Page</u>
LIST OF ILLUSTRATIONS.....	5
INTRODUCTION.....	7
SLACK WIRE PROBLEM DEFINITION.....	8
CONCEPT FORMULATION.....	11
DESIGN CONSIDERATIONS.....	11
PRELIMINARY ANALYSIS.....	15
Potential Concepts Identified.....	15
CONCEPT SELECTION.....	18
SELECTION PROCEDURE.....	18
CRITERIA FOR SELECTION.....	18
PRELIMINARY DESIGN.....	21
LAYOUT DESIGN STUDIES.....	21
DESIGN DESCRIPTION.....	22
Main Rotor Aerodynamic Fairing.....	22
Main Rotor Pitch Link Ring.....	22
Main Rotor Actuated Cutter.....	23
Main Rotor Pitch Link Cutters.....	29
Main Rotor Grip Assembly Cutters.....	29
Tail Rotor Controls Cover.....	29
Tail Rotor Shaft Cutter.....	35
Tail Rotor Shaft Cover.....	35
Tail Rotor Yoke-Mounted Cutters.....	35
Tail Rotor Pitch Link Cutters.....	35
DESIGN SUPPORT TEST.....	35
Test Equipment.....	35
Baseline Test.....	42
Pitch Link Ring.....	47
Pitch Link Cutter.....	54

TABLE OF CONTENTS (Concluded)

	<u>Page</u>
TRADE-OFF EVALUATION.....	56
PARAMETER DEFINITION.....	56
CONCEPT COMPARISONS.....	58
Main Rotor Aerodynamic Fairings.....	58
Main Rotor Pitch Link Ring.....	63
Main Rotor Actuated Cutter.....	65
Main Rotor Pitch Link Cutters.....	65
Grip Assembly Cutter.....	66
Tail Rotor Controls Cover.....	68
Tail Rotor Shaft Cutter and Shaft Cover.....	68
Tail Rotor Yoke Cutters.....	69
Tail Rotor Pitch Link Cutters.....	69
CONCLUSIONS.....	71
RECOMMENDATIONS.....	72

LIST OF ILLUSTRATIONS

<u>Figure</u>		<u>Page</u>
1	Model 206B helicopter with main and tail rotors entangled by rope .....	9
2	Model 206A helicopter swashplate damaged by monofilament line.....	10
3	OH-58 helicopter.....	12
4	AH-1 helicopter.....	13
5	UH-1 helicopter.....	14
6	Main rotor aerodynamic fairing.....	23
7	Main rotor pitch link ring.....	25
8	Main rotor actuated cutter.....	27
9	Main rotor pitch link cutter.....	31
10	Main rotor grip-mounted cutter.....	33
11	Tail rotor controls cover.....	34
12	Tail rotor shaft cutter.....	36
13	Tail rotor shaft cover.....	37
14	Tail rotor yoke-mounted cutter.....	39
15	Tail rotor pitch link cutter.....	41
16	Baseline test hub.....	43
17	Pitch link ring concept test hardware.....	44
18	Pitch link cutter concept test hardware.....	45
19	Pitch link cutter.....	45
20	Pitch link sawtoothed cutter.....	46

LIST OF ILLUSTRATIONS (Concluded)

<u>Figure</u>	<u>Page</u>
21 Horizontal wire baseline test.....	48
22 Vertical wire baseline test setup.....	49
23 Vertical wire baseline test results.....	50
24 Pitch link ring test with baseline test setup.....	51
25 Test results of pitch link ring with baseline test setup.....	52
26 Test results of pitch link ring with modified test setup.....	53
27 Kevlar orientation of cutting during modified test.....	55
28 Kevlar orientation at cutting during baseline test.....	55
29 Main rotor aerodynamic fairing and grip-mounted cutter.....	62
30 Main rotor pitch link ring and grip-mounted cutter.....	64
31 Effect of pitch link cutter blade shape on cutting motion.....	67

## INTRODUCTION

With the increased low altitude and nap-of-the-earth operation of U.S. Army helicopters, the danger and number of wire strikes have also increased. Equipping helicopters with mechanisms that will cut wires will result in fewer mishaps and casualties and improve overall mission effectiveness. The U.S. Army has procured a wire strike protection system for the OH-58 helicopter to provide increased survivability against taut wires striking the upper and lower portions of the fuselage. The remaining areas of concern are main and tail rotor blade wire strikes and the entanglement of slack wires with the main and tail rotor controls.

Wire strikes have been documented that involve hitting obstacles ranging from string- to steel-reinforced power transmission lines with diameters of less than 0.12 inch to over 1.1 inch. The larger diameter and stiffer wires are not as likely to wrap around rotating controls when these wires become slack. The danger of a mishap due to slack wires generally involves monofilament line, string, communication wire, and TOW missile wires that have been broken. These wires are relatively flexible and lightweight, which makes them susceptible to being picked up by the main rotor and wrapped around the rotating controls.

The WSPS is very effective on taut wires but will not protect the rotating controls from slack wire damage. A system is needed that will protect the rotating controls from binding and bending from the wrapping of slack wires. This report identifies and develops various main and tail rotor protection concepts into systems that effectively meet this need for controls protection.

### SLACK WIRE PROBLEM DEFINITION

There have been many instances of slack wires, strings, and ropes that have wrapped around main and tail rotor shafts and controls of military and civil helicopters. One or two wraps of wire would not pose a threat; however, many windings have an additive effect. In the case of rotating controls, very light wire or string with many wraps can bind or collapse the pitch links causing difficulty or loss of control of the aircraft. Figure 1 shows a rope from a balloon that wrapped around the main and tail rotor controls. Because it turns five times faster than the main rotor, the tail rotor has many more windings.

Slack wires could be oriented in any manner in space when they are "caught" by the helicopter. Taut wires are generally horizontal and pose problems for the fuselage (cabin or landing gear). The slack wires can be pulled into the main or tail rotor by the inflow of air or "dragged" across the fuselage into the controls. Slack wires that pose the greatest threat for entanglement with controls are generally small in diameter, lightweight, and very flexible. These wires can be metallic, plastic, or organic in composition and very long.

A particular problem with small diameter wires is that they can cut bolts and seals and penetrate bearings as well as wrap around controls. Figure 2 shows the nonrotating inner ring of a swashplate that was damaged when a kite being flown with monofilament line was struck. The kite line wound around the ring and cut a groove 1/8-inch wide by 3/64-inch deep. Another potential military threat is the injection of wires or strings into the paths of helicopters. The organic fiber, Kevlar, would be a significant threat due to its low density, high tensile strength, abrasion resistance, and fracture toughness.

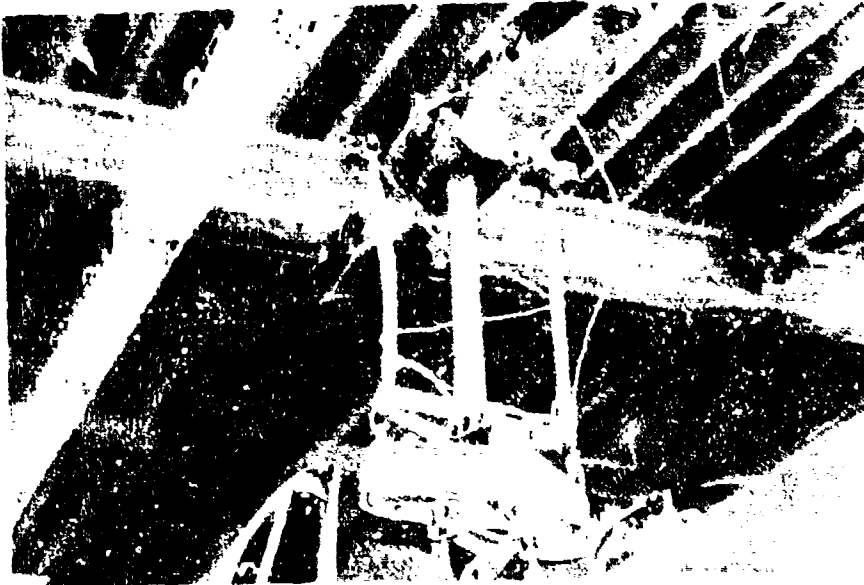

2  
F



Figure 1. Model 206B helicopter with main and tail rotors entangled by rope.



Figure 2. Model 206A helicopter swashplate damaged by monofilament line.

## CONCEPT FORMULATION

### DESIGN CONSIDERATIONS

Guidelines and design requirements, which influenced the type of concepts selected, were initially established in the contract. The baseline helicopter was an OH-58A equipped with a WSPS for taut wire cutting. The primary design consideration was to protect the main and tail rotor pitch change links to prevent loss of helicopter control by the pilot. Both active and passive concepts attached to either the rotating controls or airframe were to be considered. Passive concepts included fixed cutters, guards, deflectors, and fairings.

Also to be considered was the adaptability of the baseline concepts to UH-1 and AH-1 helicopter usage. As stated earlier, the OH-58A was used as the baseline helicopter for the generation of concepts. Figure 3 shows three-view sketches of the OH-58A helicopter with close-ups of the main and tail rotor control systems. Figures 4 and 5 show the AH-1 and UH-1 helicopters, respectively. The upper fairing of the AH-1 helicopter completely shields the fixed controls and swashplate, thus preventing slack wires from becoming trapped in this area. The upper fairing of the UH-1 helicopter leaves much of the fixed controls and swashplate exposed, leaving more places for catching slack wires. The UH-1 helicopter also has a stabilizer bar assembly that further complicates the rotating controls. The OH-58A and AH-1 helicopters do not have stabilizer bars. Consequently, a slack wire protection system for the main rotor controls of the OH-58A and AH-1 helicopters would be primarily concerned with the rotating pitch links. Such a system would not be as effective on the UH-1 helicopter.

The tail rotor of the OH-58A helicopter is attached to one side of the tailboom; the vertical fin is attached to the other side and extends above and below the tail rotor. The tail rotors of the AH-1 and UH-1 helicopters are attached to the top of the vertical fin exposing more of the tail rotor at some cruise attitudes, where the tail rotors are above the main rotor. This increases the probability of picking up slack wire. The AH-1 and UH-1 tail rotors also employ active counterweight assemblies that extend much further beyond the tail rotor hub than the OH-58A tail rotor, which has a much simpler control system.

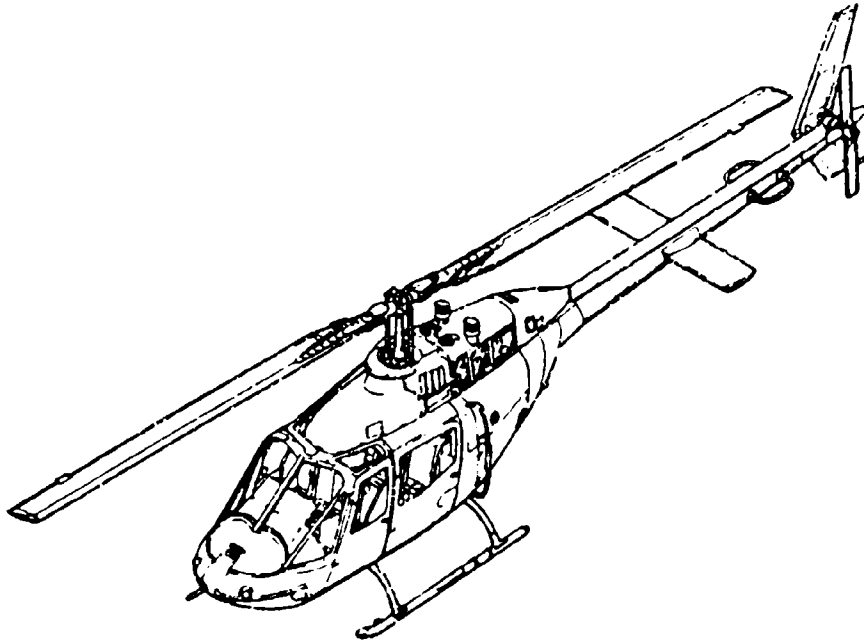

Main Rotor Controls

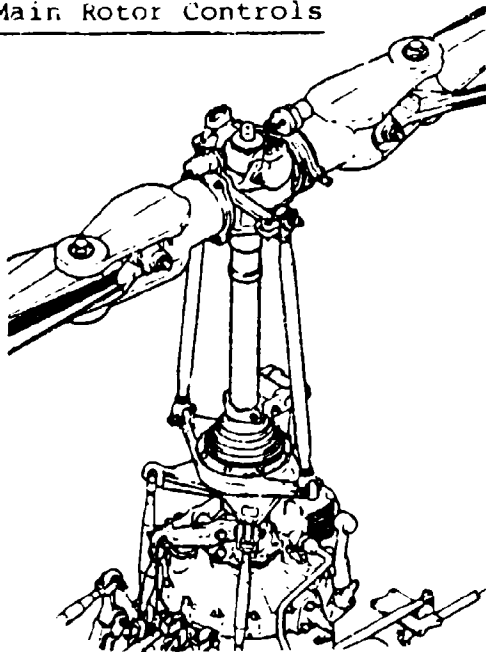

Tail Rotor Controls

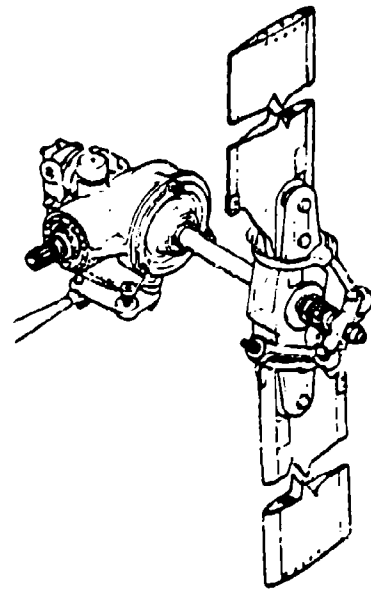
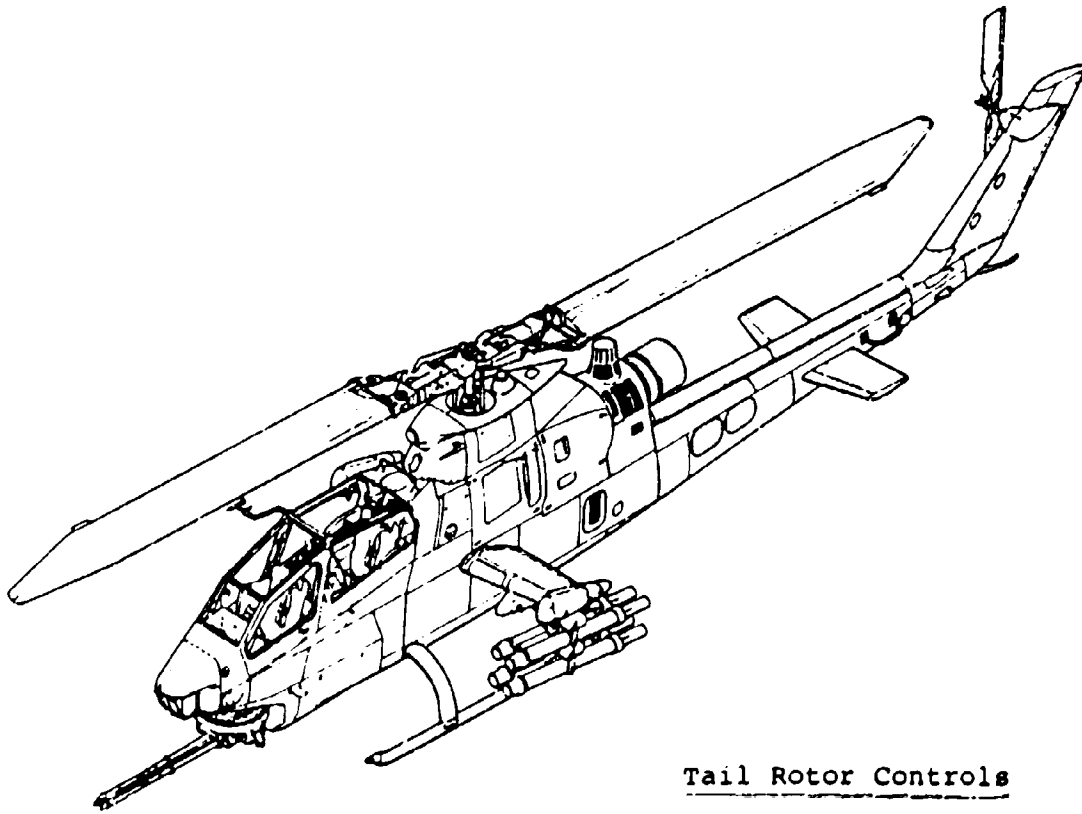

Figure 3. OH-58 helicopter.



Tail Rotor Controls

Main Rotor Controls

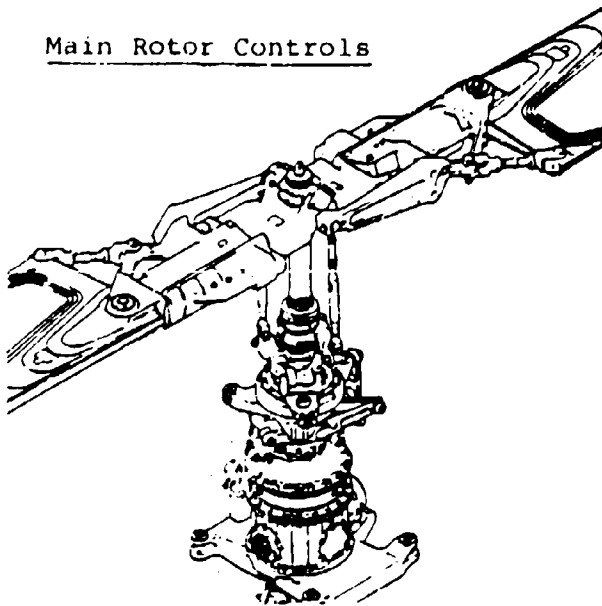
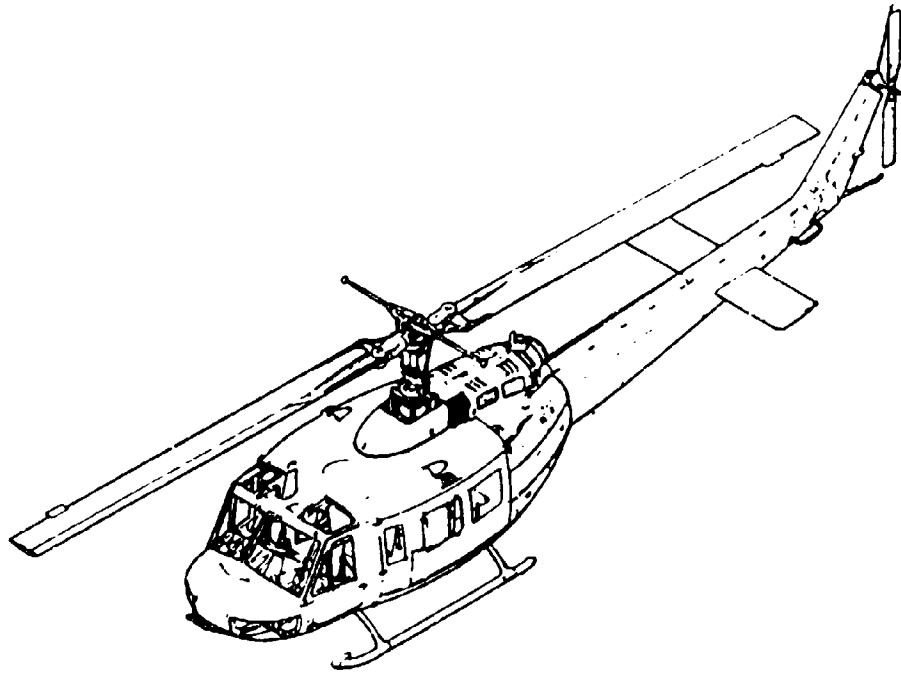

Figure 4. AH-1 helicopter.



Tail Rotor Controls

Main Rotor Controls

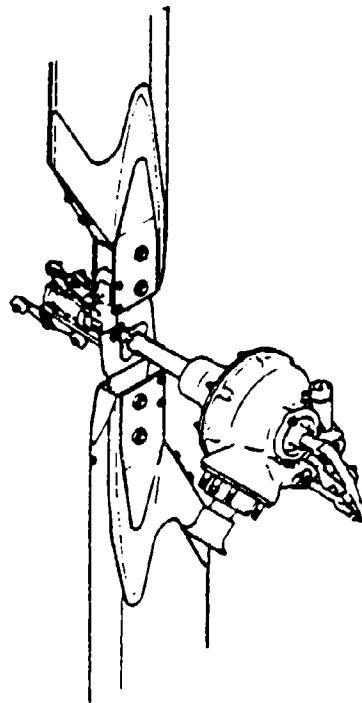
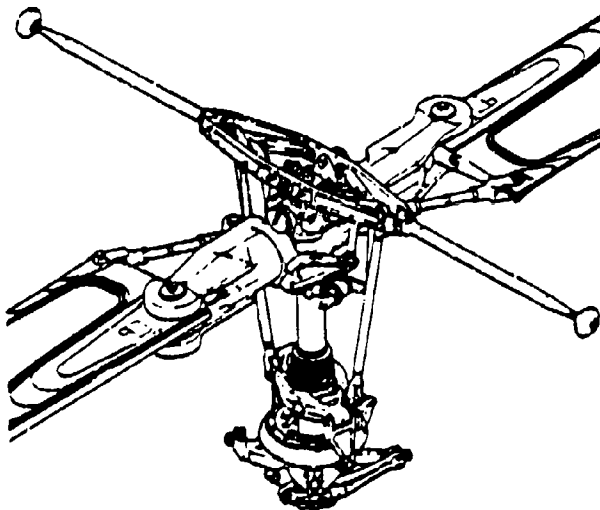

Figure 5. UH-1 helicopter.

For the slack wire protection concepts that will be devised for the OH-58A helicopter, consideration will be given as to how these concepts could be employed on the AH-1 and UH-1 helicopters. But, the concept development effort and all subsequent refinements will be limited to the OH-58A helicopter.

#### PRELIMINARY ANALYSIS

##### Potential Concepts Identified

Ideas and approaches for slack wire strike protection concepts were generated during brainstorming sessions attended by Engineering Design, System Safety, and Stress personnel. Attendees were briefed about the problem of slack wire entanglement and the necessary design considerations as discussed earlier. Concepts were not evaluated during the initial sessions to generate a larger base from which to select and to prevent concepts from being deleted prematurely without some development.

Twenty-four main rotor and sixteen tail rotor protection concepts were identified and are briefly described below:

##### Main Rotor Shielding Devices

- Fairing extending from existing cowl to rotor.
- Rotating spool (attached to pitch links) incorporating flanges to retain wire.
- Coarse mesh wire (shaped similar to fairing) extending from existing cowl to rotor.
- Four vertical bars attached to cowl around rotating controls.
- Protective cylinder around each pitch link, which allows controls to work after cylinders are wrapped with wire.
- Slip-jointed tubes attached to the rotor hub and swashplate outside of the pitch link radius.

Main Rotor Passive Cutting Devices. (Cutters do not move relative to mounting surface.)

- Cutter mounted forward of mast on centerline of ship.
- Straight blade on pitch links.
- Sawtooth blade on pitch links.
- Sharp blades mounted along leading edge of hub.
- Sharp blades mounted on hub perpendicular to rotor disc.
- Sharp blades mounted on fixed swashplate ring.
- Cutters mounted on outside and inside of fairing.
- Hook/notch cutter mounted on rotor tip.
- Hook/notch cutter mounted at root of blade on leading edge.
- Hook/notch cutter mounted on rotating swashplate ring.

#### Main Rotor Active Cutting Devices

- Scissor mechanism, operated from collective motion, mounted on fixed swashplate and housing.
- Shear or reciprocating sawtooth cutter mounted on centerline forward of mast (manual or automatic).
- Cam-operated blade that would cut wire between pitch links.
- Centrifugal mechanism that automatically deploys at operating rpm with cutting done as tension in wire increases (stowed at static position).
- Cam-operated cutter at swashplate with tubes attached to rotor hub and swashplate to guide wire into cutter.

#### Main Rotor Advanced Concepts. (Remove wire by burning.)

- Laser device.

- Electrical discharge.
- Engine bleed air heat.

#### Tail Rotor Protection Device

- Fairing around pitch links and yoke.
- Fairing around pitch links.
- Fairing around shaft (mast) mounted onto gearbox.
- Wire mesh (shaped similar to fairing) around pitch links.
- Wire mesh device around shaft (mast).
- Rotating cylinder around shaft (mast).

#### Tail Rotor Passive Cutting Devices

- Hook/notch cutter mounted at the root of blade on leading edge.
- Sharp blade mounted along leading edge of yoke.
- Hook/notch cutter mounted on rotor tip.
- Blade mounted on pitch links.
- Blade mounted on gearbox along shaft (mast).
- Blade on hub outside pitch link/blade attach point radius.

#### Tail Rotor Active Cutting Devices

- Reciprocating sawtooth cutter mounted on transmission.
- Centrifugal mechanism automatically deployed at operating rpm with cutting done as tension in wire increases (stowed at static position).

#### Advanced Concepts. (Remove wire by burning.)

- Laser device.
- Electrical discharge.
- Engine bleed air heat.

## CONCEPT SELECTION

### SELECTION PROCEDURE

A qualitative evaluation was conducted by Engineering Design personnel in which concepts suitable for refinement during preliminary design were selected from the potential concepts identified in the Preliminary Analysis section. Engineering sketches of each potential concept were developed into a design for use in the evaluation. These designs were developed for effectiveness, low weight, low cost, minimal impact on helicopter operation, and maximum safety to ground personnel. These sketches depicted major components in each design with enough detail to identify local attachment requirements, areas of protection, and approximate component sizes and locations relative to the helicopter.

### CRITERIA FOR SELECTION

The concepts to be refined were selected based on their effectiveness, technical feasibility, impact on basic helicopter operation, and adaptability to UH-1 and AH-1 helicopters. Effectiveness was considered to be a measure of how well a concept protected main or tail rotor pitch links from various slack wire threats. These threats included:

- Thin material - TOW wire.
- Pliable material - monofilament line or Kevlar.
- Thick material - communication wire or loose power lines.
- Material picked up by rotor wash.
- Horizontal slack material.
- Vertical slack material.
- Material trailing from WSPS or other helicopters.
- Multiple occurrence.

For a concept to be considered effective, it had to show the potential of protection from a large number of these threats.

Technical feasibility was considered to reflect the amount of risk associated with each concept. Concepts that were complex or that relied on unproven technology would require a great deal of refinement to arrive at an effective concept and thereby limit the total number of concepts developed. For this reason, concepts that could be refined into effective designs in a reasonable amount of time using present technology were selected.

The effectiveness and feasibility of each concept was the primary consideration for selection; adaptability and impact on helicopter operation were secondary considerations. A concept's impact on helicopter operation included any detrimental effect it had on rotor vibration, handling qualities, or scheduled maintenance.

Complex mechanisms in most cases received a low rating in both feasibility and effect on helicopter operation. The design concepts that incorporated complex mechanisms were less reliable and more difficult to install and maintain. If these concepts were in the rotating system, they would significantly affect vibration if out of adjustment, installed improperly, or worn. The concepts selected for refinement during preliminary design are listed in Table 1.

TABLE 1. CONCEPTS SELECTED FOR REFINEMENT

---

Main Rotor Protection Concepts

- a. Shielding Devices
  - 1. Fairing extending from existing cowl to rotor
  - 2. Four vertical bars attached to cowl around rotating controls
- b. Passive Cutting Devices
  - 1. Sharp blade forward of mast on centerline of helicopter
  - 2. Straight blade on pitch links
  - 3. Sawtoothed blade on pitch links
  - 4. Sharp blades on hub perpendicular to rotor disc
- c. Active Cutting Devices
  - 1. Powered shear mounted forward of mast on centerline
  - 2. Reciprocating cutter mounted forward of mast on centerline

Tail Rotor Protection Concepts

- a. Shielding Devices
    - 1. Fairing around pitch links and yoke
    - 2. Fairing around shaft fixed to transmission case
  - b. Passive Cutting Devices
    - 1. Sharp blade along shaft mounted onto transmission case
    - 2. Sharp blade on pitch links
    - 3. Sharp blade mounted on hub outside pitch link/blade attachment radius
-

## PRELIMINARY DESIGN

### LAYOUT DESIGN STUDIES

The design concepts listed in Table 1 were refined during preliminary design to the extent that their individual characteristics could be defined. These characteristics were used in a trade-off evaluation in which the most promising of the design concepts were determined. The characteristics identified for each concept during preliminary design were:

- Effectiveness
- Weight
- Cost
- Retrofitability
- Adaptability to UH-1 and AH-1 helicopters
- Effect on helicopter dynamics
- Effect on helicopter structure
- Effect on helicopter performance
- Interference with helicopter maintainability
- Effect on helicopter radar cross section
- Hazard to ground personnel

Quarter-size layouts were made of each design concept installed on the helicopter with full-size details of local attachments, airframe modifications, and cross sections. Also depicted on each layout were appropriate fuselage structure, rotating controls, and hub details with control motions. Additional information given on the layouts included:

- Material type and thickness
- Fabrication techniques
- Fastener quantities, type and size

## DESIGN DESCRIPTION

The design concepts that resulted from the design studies are shown in Figures 6 through 15 and are discussed below.

### Main Rotor Aerodynamic Fairing

The fairing shown in Figure 6 is attached to the existing engine inlet cowl and extends to the lower side of the main rotor hub. The main rotor flapping extremes established the fairing height. The fairing is constructed of lightweight honeycomb core with fiberglass skin. For ease of removal during maintenance or inspections, the fairing is made in two pieces and quick-release fasteners are used throughout. Modification to the basic airframe involves installing approximately 21 quick-release fastener receptacles and a riveted doubler strip.

### Main Rotor Pitch Link Ring

The pitch link ring shown in Figure 7 is attached to the top of the existing engine inlet cowl and extends to the lower side of the main rotor hub. The design consists of a flat ring positioned around the pitch links beneath the hub and supported by four vertical aluminum tubes. The height and outer diameter of the ring were established by flapping extremes. The tubes are attached to the ring and engine inlet cowl with cast aluminum fittings. The upper fittings incorporate cutting surfaces. The ring is constructed in two pieces for ease of installation. The basic ring is honeycomb core and fiberglass skin with a thin steel cutting edge in the middle of the frame, which also serves as a doubler at the splice area. Modification to the basic airframe involves bonding aluminum doublers that have nutplates attached to them at each lower attachment fitting location.

### Main Rotor Actuated Cutter

The actuated cutter is mounted on the centerline of the engine inlet cowl forward of the mast. The powered shear and reciprocating blade cutters were considered to be similar designs and are shown in Figure 8. The wire guide has a sharp edge for static cutting and the lower blades of each concept are driven by an electrical ram. The ram for the shear cutter is a solenoid device that recycles after use. The ram for the reciprocating cutter is a motor. The shear cutter incorporates a switch that detects wire material and activates the ram until the material is removed. The reciprocating cutter would run continuously while in a threat area.

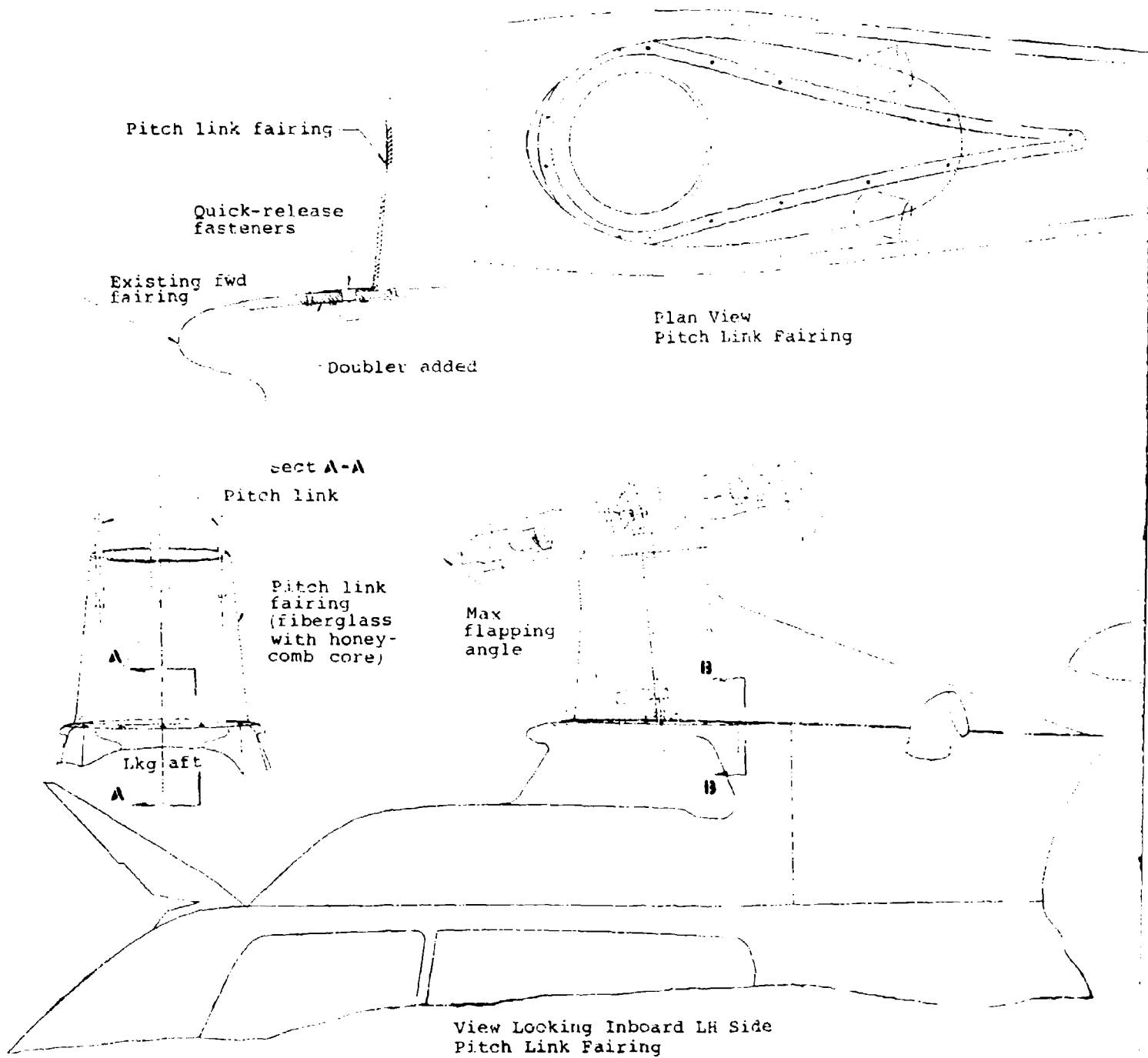
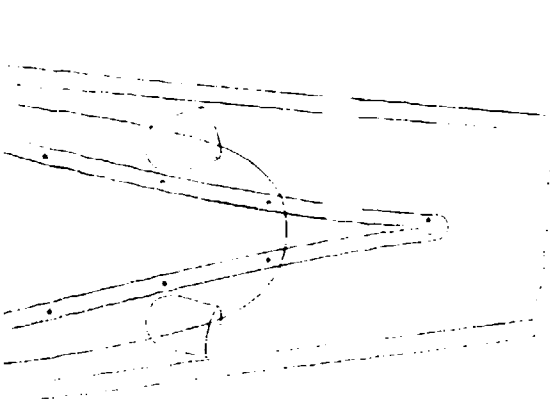
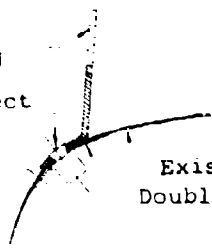

Figure 6. Main rotor aerodynamic fairing.



Pitch link fairing

Quick-disconnect  
fasteners



Existing cowl ref  
Doubler (added)

Sect 13-13

Pitch link

nk Fairing

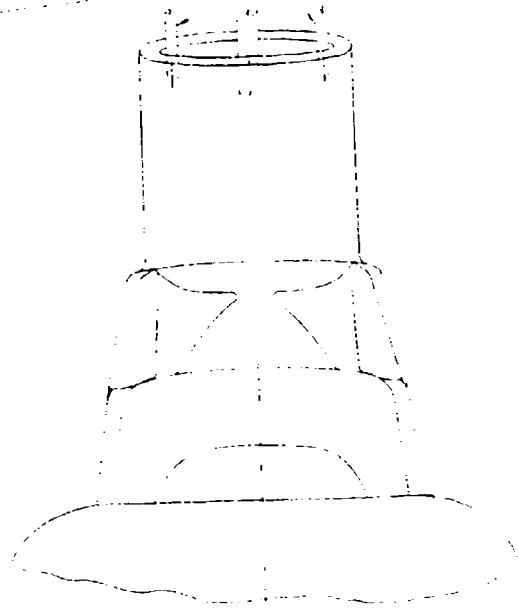

View Looking Aft  
Aerodynamic Fairing



ide

- Ring fastened together
- Skin of ring
- 3-ply fiberglass
- Doubler in splice area (.063 al aly)
- Honeycomb core

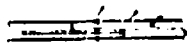

C-C  
Rotated 90° CCW

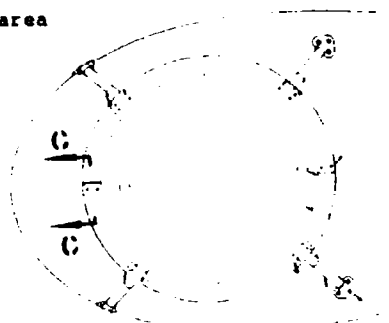

- Ring made in two (2) pieces for ease of instl

- Pitch link
- Pitch link travel

Cast fitting fastened to existing cowl (typ)

Tubing (typ)  
Cast fitting fastened to ring (typ)

Max flap angle

Cutter (cast as part of fitting)



B-B

Fitting fastened with rivets or bond  
Fitting (casting al aly)

Fitting (casting al aly)

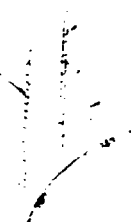

A-A

0 1 2 3 4 5  
Scale in Inches

Tubing (.080 wall al aly)  
Tubing fastened with rivets or bond

Fitting fastened with bolts or screws

Bonded doubler with nutplates (.063 al aly)

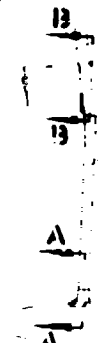

B-B

B-B

A

A

Ring Pitch link

0 5 10 15  
Scale in Inches

Figure 7. Main rotor pitch link ring.

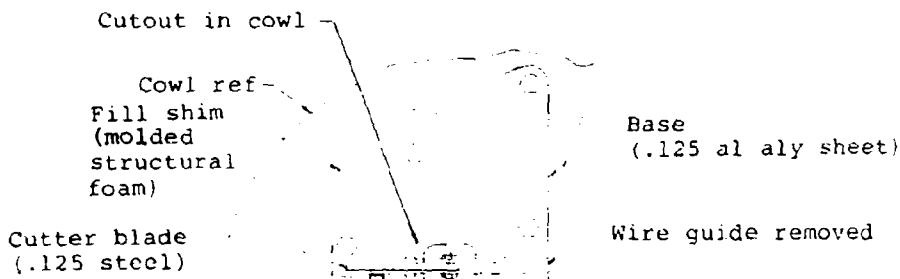

Wire guide

Cutter mechanism  
(see full scale)

Wire guide  
(.125 al aly sheet)

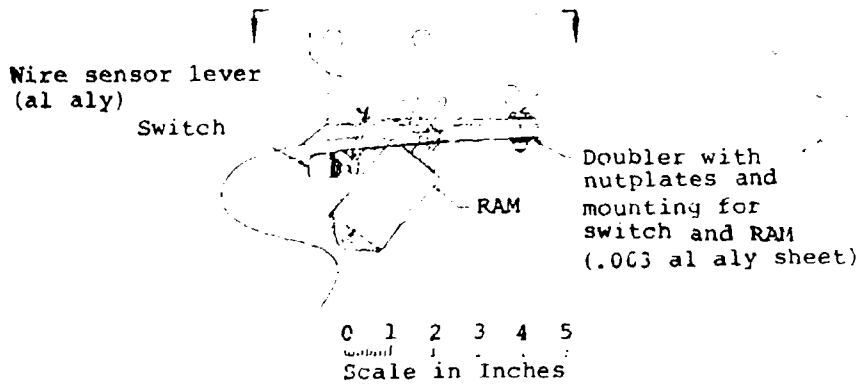

0 5 10  
Scale in In

Figure 8. Main rotor actuated cutter.

Base and mounting  
same as wire guide

Stationary cutter  
(.125 steel aly)

Moving cutter  
(.125 steel aly)

No sensing  
device shown

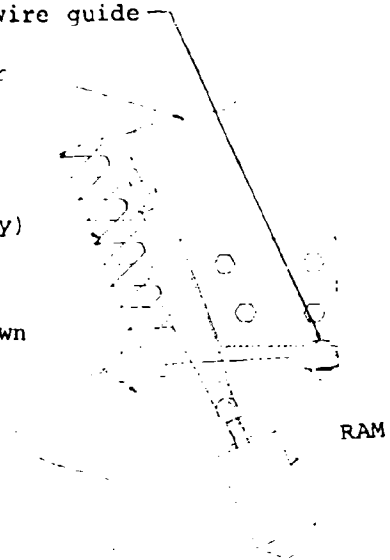

Hedge trimmer-type  
actuated cutter

0 1 2 3 4 5  
Scale in Inches

Wire guide

Cutter mechanism  
(see full scale)

0 5 10 15  
Scale in Inches

### Main Rotor Pitch Link Cutters

As shown in Figure 9 the pitch link cutters are mounted along the pitch links facing outward. Used in conjunction with the pitch link cutters is a single blade mounted on the centerline of the engine inlet cowl forward of the mast. The straight blade and sawtoothed blade designs are shown together due to the similarities in their design. Two methods of pitch link blade attachment are depicted.

In one method, a cutter is mechanically fastened to existing pitch links; the other method incorporates a welded steel tube and blade assembly. Three configurations of the stationary cutting blade are also shown. Modification to the basic airframe involves bonding an aluminum doubler and nutplate assembly at the base of the forward stationary cutter.

### Main Rotor Grip Assembly Cutters

As shown in Figure 10, the main rotor grip cutters are located inboard of the blade bolts and perpendicular to the feathering axis. The cutter is attached to the main rotor grip with a two-piece cast aluminum clamp. The blade is bolted to the clamp for easy replacement during maintenance. As shown in Figures 29 and 30, the grip cutters are used in conjunction with other concepts discussed in this report to form protection systems. No modification is required to the basic helicopter.

### Tail Rotor Controls Cover

As shown in Figure 11, the tail rotor controls cover concept totally encloses the pitch change mechanism. The installation has four parts: a dome-shaped thermoplastic outer cover, an aluminum-stamped support ring, and two aluminum-stamped inner cover halves. To install the cover assembly, the support ring is first secured to the shaft. The inner and outer covers are then screwed to the support ring and the inner cover halves clamped to the shaft. Cutouts are provided in the inner cover halves to allow clearance for tail rotor flapping. The small deflectors on the blade root prevent thin wire material from wrapping around the ends of the yoke at the feathering bearings and locking up pitch change of the blade.

PRECEDING PAGE BLANK NOT FILLED

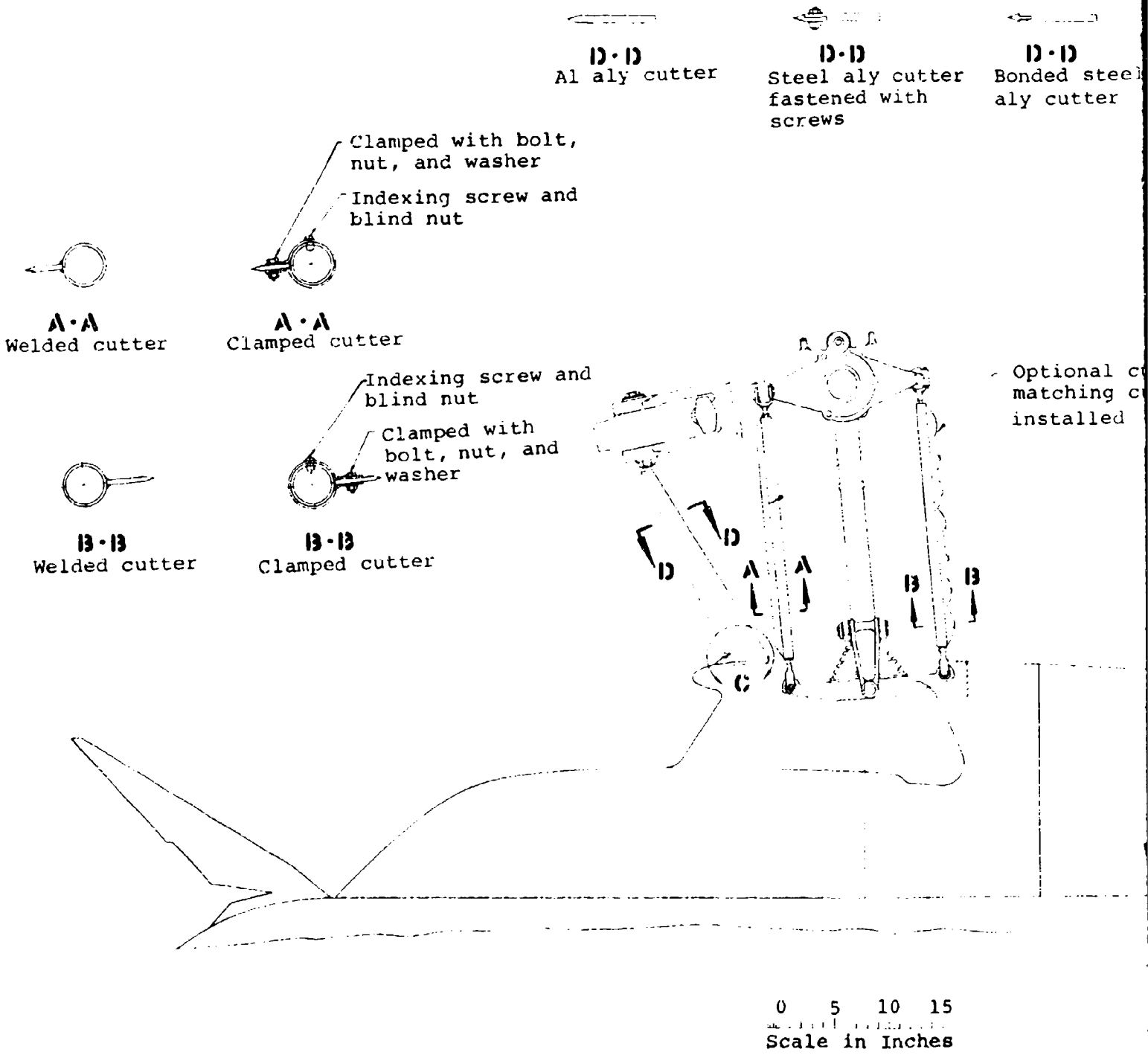
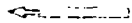

Figure 9. Main rotor pitch link cutter.

PRECEDING PAGE BLANK NOT FILLED



**D-D**

cutter  
with Bonded steel  
aly cutter

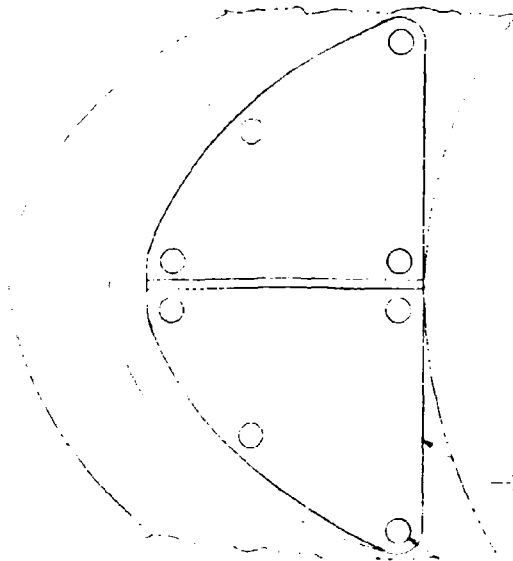

-Base  
(.125 al aly)

Optional cutters shown  
matching cutters to be  
installed

Screw and washer

Fill shim

Cutter  
(.180 al aly)

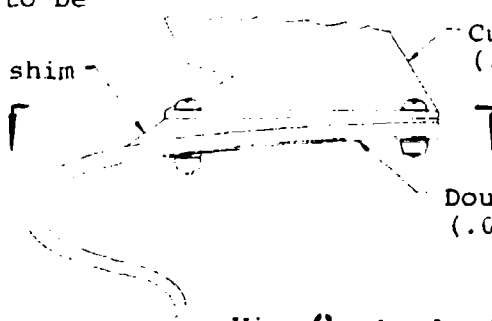

Doubler with nutplates  
(.063 al aly sheet)



View C: 0 1 2 3 4  
Full Scale hundred Scale in Inches

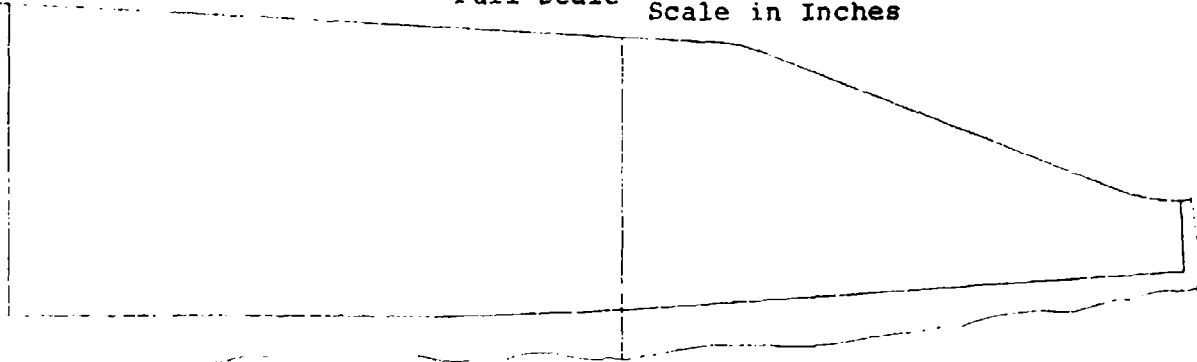

0 15  
nches

2

Clamp fasteners

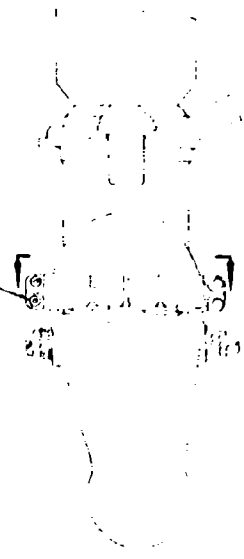

Cutters mounted  
on grip assy

0 5 10  
Scale in Inches

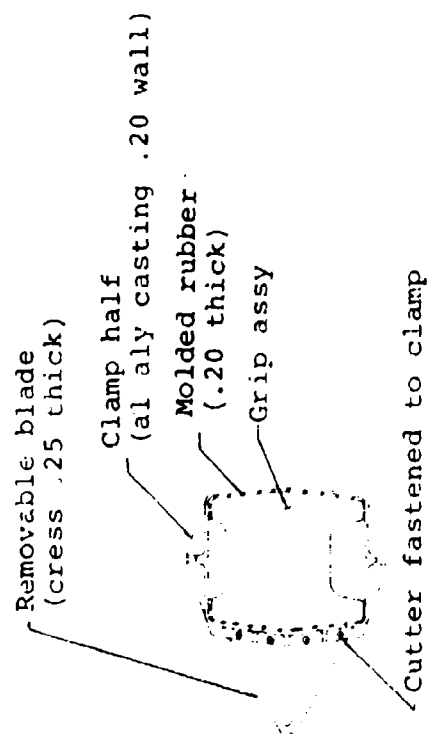

Cutter fastened to clamp

Figure 10. Main rotor grip-mounted cutter.

Outer cover and inner cover halves fastened to support ring with screws and washers

Inner cover halves fastened to shaft with clamp

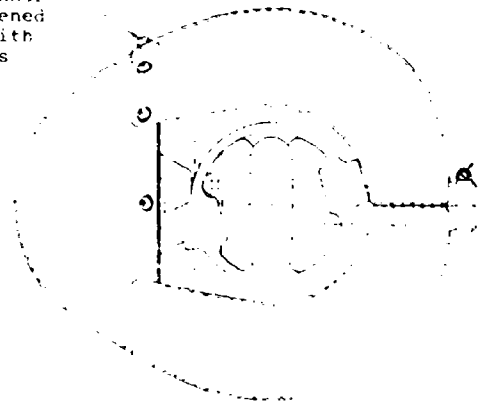

Wire deflector on blade root

Inner cover half (al aly .020 stamping)

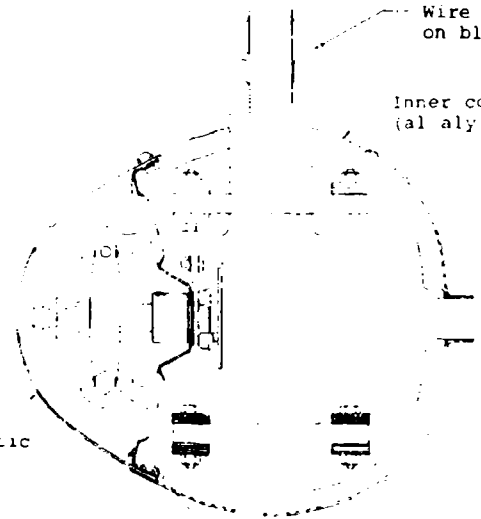

Outer cover (thermoplastic .060 thick)

Nutplates on support ring

Support ring (al aly .063 stamping)

0 1 2 3 4 5

Scale in. inches

9  
B

Figure 11. Tail rotor controls cover.

### Tail Rotor Shaft Cutter

The tail rotor shaft cutter, as shown in Figure 12, is positioned approximately parallel to and forward of the tail rotor shaft. The cutter is a welded assembly and is attached to the gearbox using existing studs. The length of the cutting blade was established by tail rotor flapping.

### Tail Rotor Shaft Cover

The tail rotor shaft cover is shown in Figure 13. The cover is nonrotating and is attached to the gearbox using existing studs. The cover is constructed of two aluminum-stamped cover halves that are screwed together at installation.

### Tail Rotor Yoke-Mounted Cutters

The tail rotor yoke-mounted cutters are shown in Figure 14. In the method of fabrication shown, the cutters are attached to the existing blade pitch arm castings. The cutters are castings with their attachment holes counterbored to provide clearance with the yoke. In another method of fabrication, which is not shown, the blade is integral to the pitch arm casting and replaces the existing part.

### Tail Rotor Pitch Link Cutters

The tail rotor pitch link cutters are shown in Figure 15. The cutters are mounted along the links and face outward. Two methods of blade attachment to the pitch links are depicted. In one method, the cutter is mechanically fastened to existing links. The other method uses a link with an integral blade.

## DESIGN SUPPORT TEST

In support of the preliminary design effort, simplified tests were performed to obtain a better understanding of how slack wire wraps around rotating controls and to verify the feasibility of two selected main rotor protection concepts.

### Test Equipment

Test Stand. An existing main rotor whirl stand was configured with an OH-58 hub, pitch links, and associated hardware. Because of the area available for testing, blades were not installed on the hub. The pitch links were half the length and stiffer than standard OH-58 links and, due to the method of lower attachment, provided no pitch change to the hub.

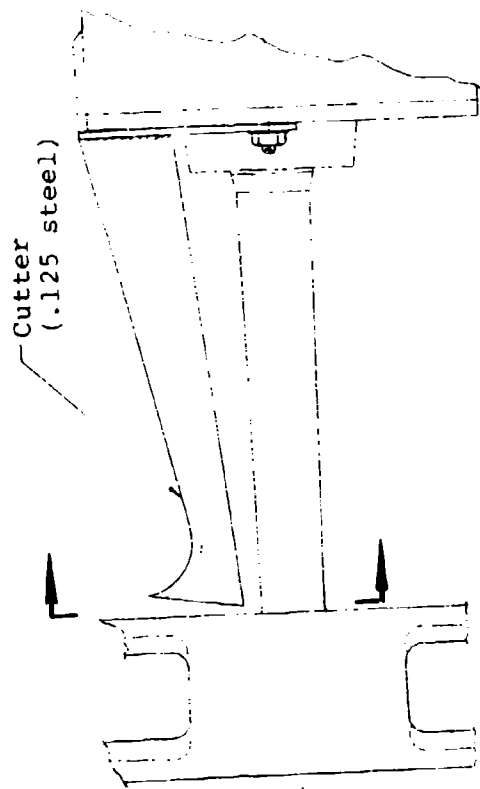

Tail Rotor Concept No. 2

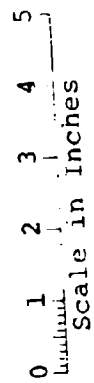

Mounting plate  
(.125 steel)

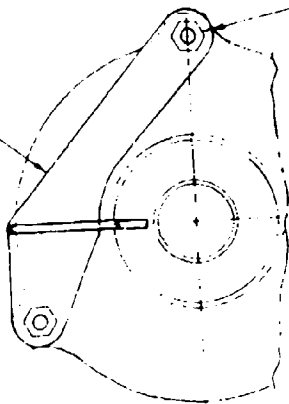

Fastened with  
existing gear-  
box studs

Figure 12. Tail rotor shaft cutter.

Fastened together with screws and nutplates for easy installation

Fastened to gearbox with existing studs  
Cover halves  
(Stamped .063 al aly)

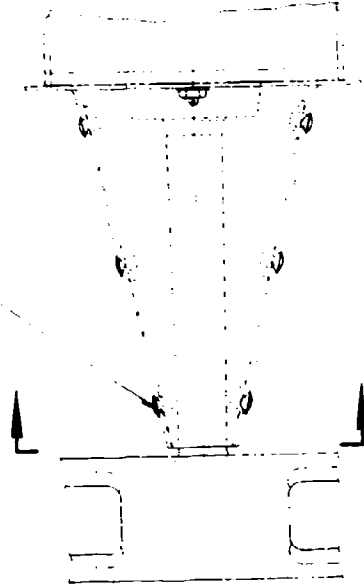

Tail Rotor Concept No. 3

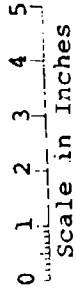

Figure 13. Tail rotor shaft cover.

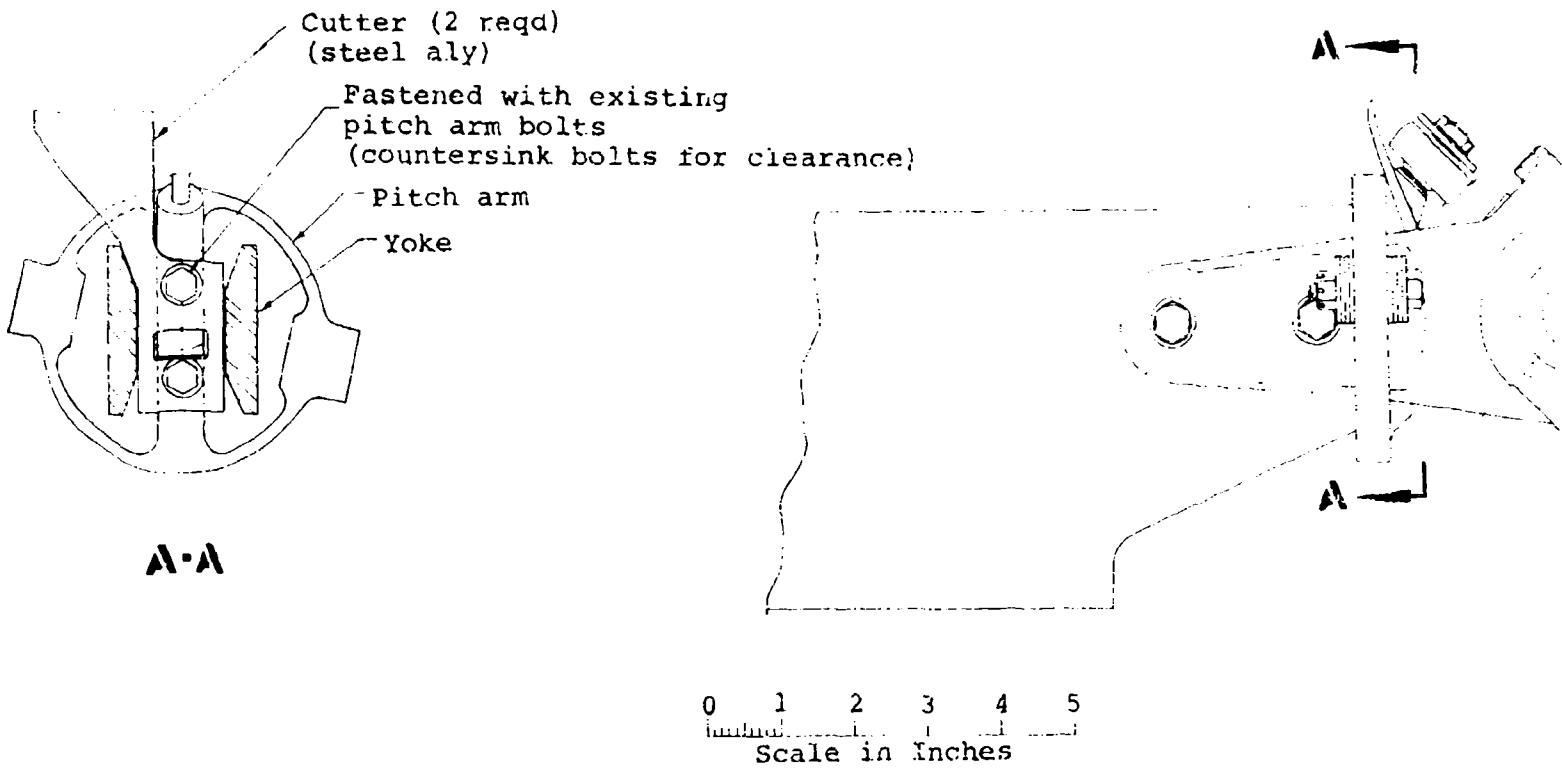
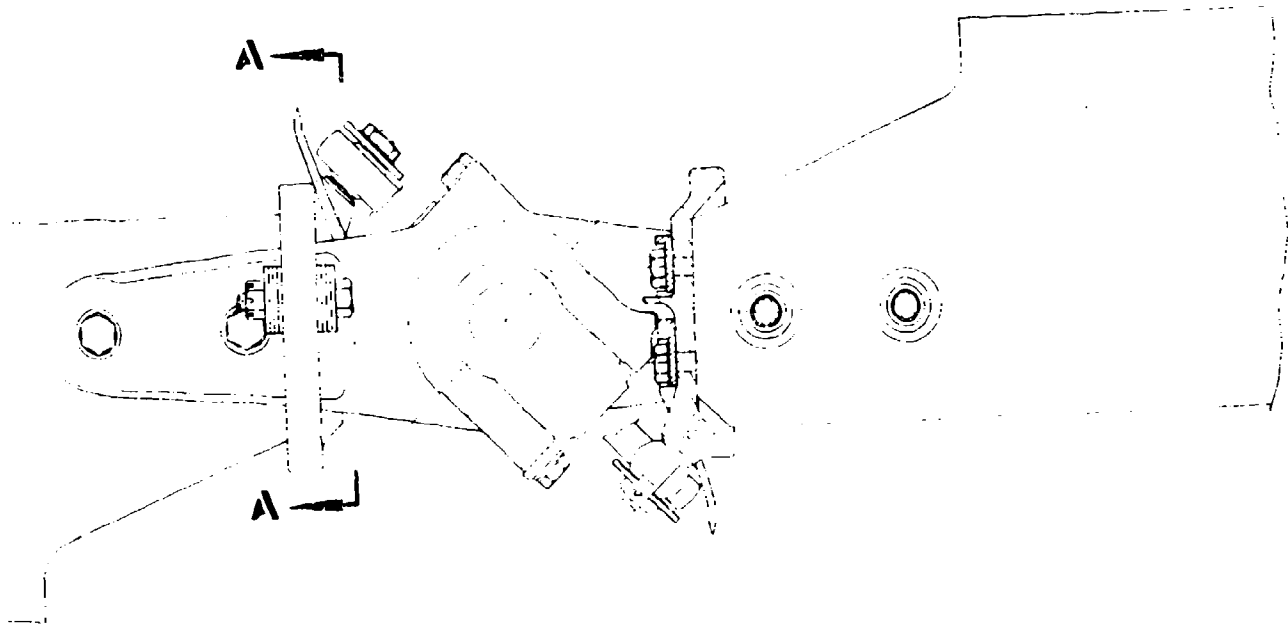

Figure 14. Tail rotor yoke-mounted cutter.



5

2

4

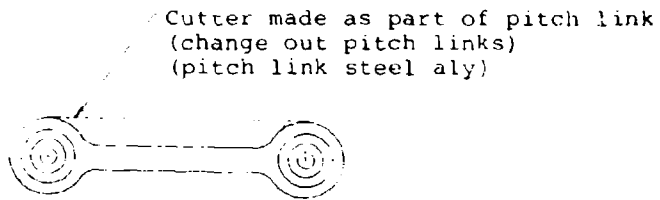
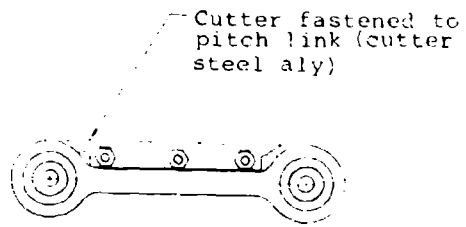

Pitch links with cutters

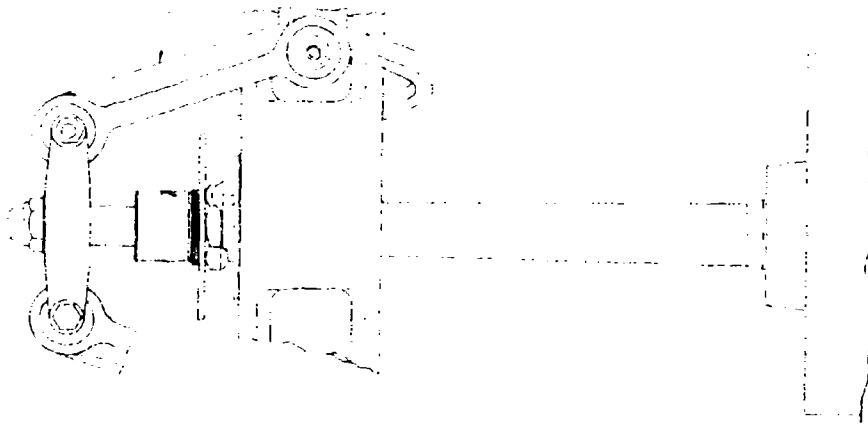

0 1 2 3 4 5  
 Scale in Inches

Figure 15. Tail rotor pitch link cutter.

This hub is shown in Figure 16. The hub and pitch links were belt driven at 300 rpm by a 75-hp electric motor.

Protection Concepts. Two protection concepts were selected for testing, the pitch link ring and the pitch link cutters similar to those shown in Figures 4 and 6, respectively. The pitch link ring concept, as shown in Figure 17, was fabricated using an aluminum upper ring with the outer diameter sharpened for its cutting surface. The height of the ring was approximately half of actual size due to the test stand geometry. As shown in Figure 18, two blade shapes (straight and sawtooth) were tested on the pitch links to determine which blade was more effective in cutting the various materials. The type of cutter to be evaluated was selected by adjusting the pitch link rod ends such that the pitch link could be rotated to position the desired cutter on the outermost surface of the link. As seen in Figure 19, the edge on the straight blade was fairly blunt, approximately a 90-degree included angle. The sawtooth blade, as shown in Figure 20, had a flat sloping cutting surface similar to a shear with the notched area a smooth radius. The sharpness of both blade types was considered to be realistic and easily maintainable in actual service.

Wire Material. Three types of wire material were tested - Kevlar, communication wire, and TOW wire. The Kevlar material was 60 end count roving with each end containing 134 filaments. Two lengths of communication wire were intertwined and tested together. Each length of wire was composed of five strands of steel wire covered with an insulation material. Two lengths of TOW wire were also intertwined and tested together.

#### Baseline Test

Initial testing was conducted on the basic test stand (unprotected standard test pitch links) configured as shown in Figure 16. The purpose was to learn more about the mechanism involved in pitch link wrapping from horizontal and vertical slack wire material.

Horizontal Wire Material. The first attempt at wrapping wire material around the pitch links and generating high collapsing forces was unsuccessful. One end of a 10-foot length of Kevlar roving was secured to a pitch link and loosely wound around the links with the other end secured to the mast. There was no change in roving tension after hub rotation for

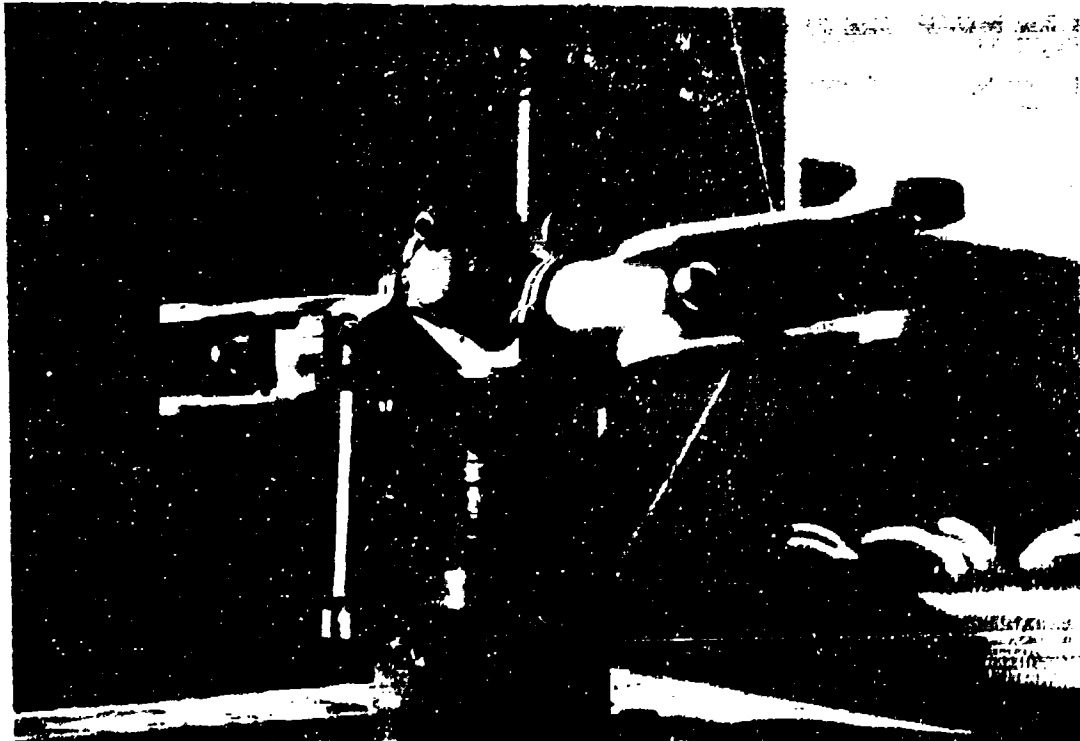
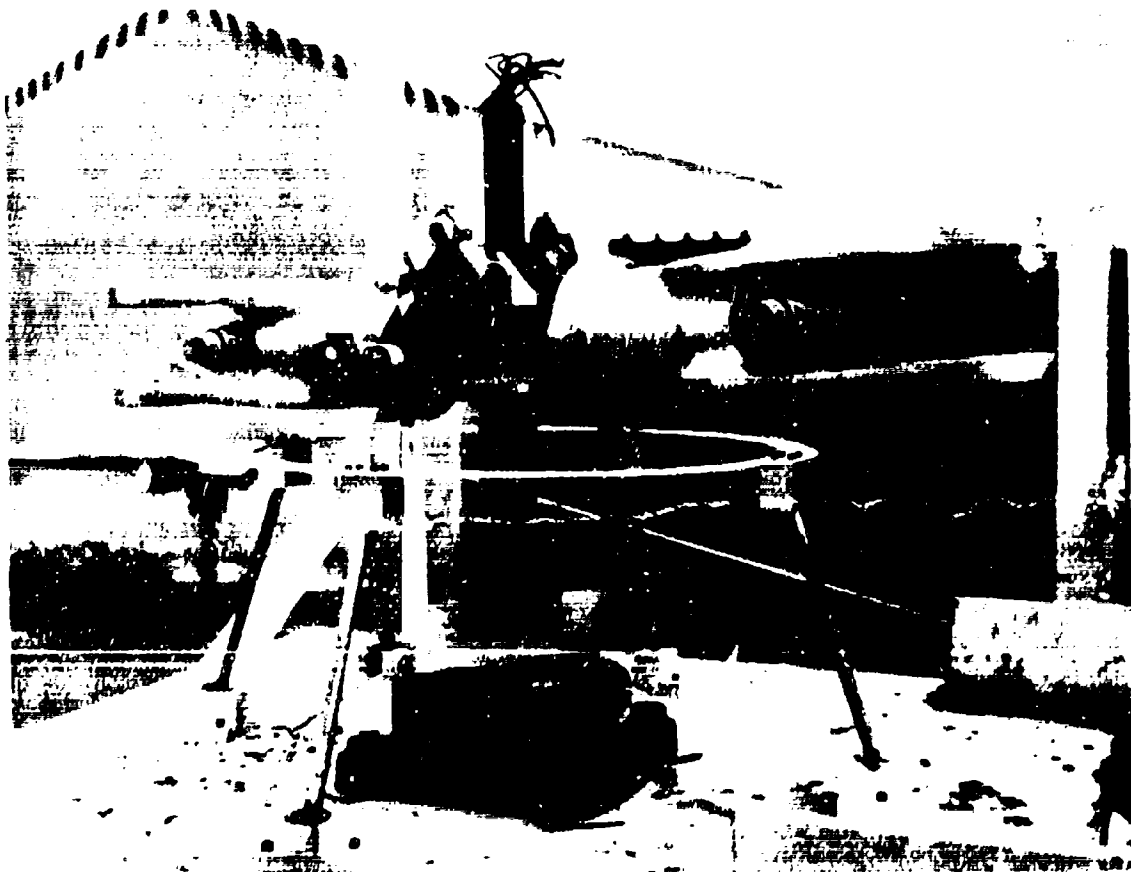

Figure 16. Baseline test hub.



10  
B

Figure 17. Pitch link ring concept test hardware.



Figure 18. Pitch link cutter concept test hardware.

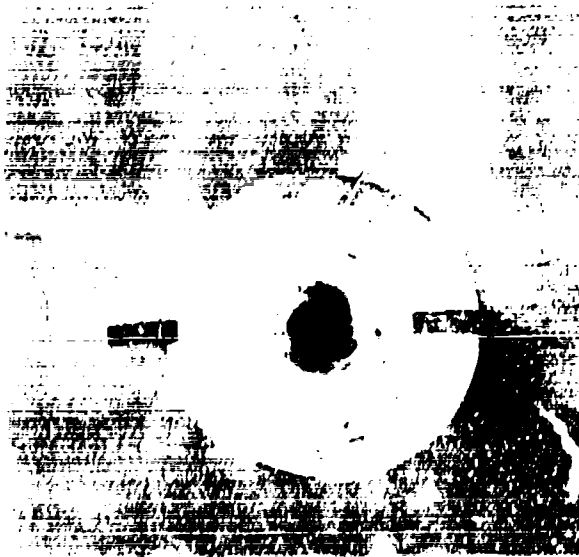

Figure 19. Pitch link cutter.

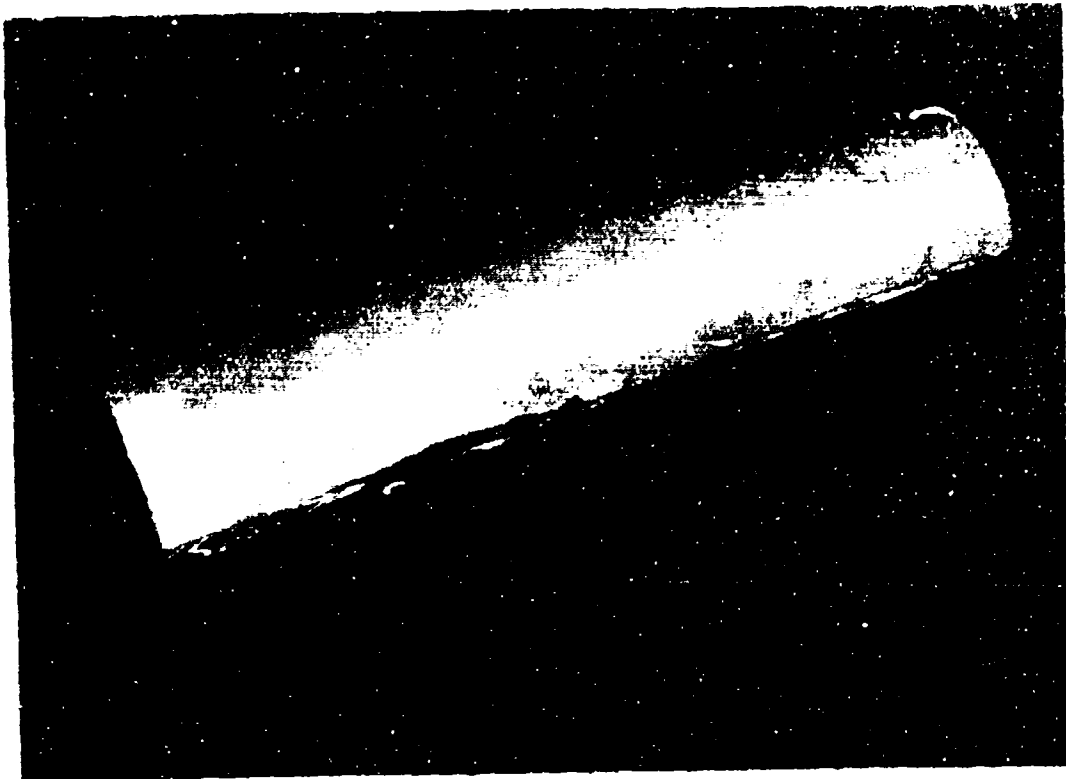

Figure 20. Pitch link sawtoothed cutter.

approximately 4 minutes. However, high collapsing forces were produced when 4 to 5 pounds of tension was applied to the Kevlar as it wrapped around the pitch links. The means of applying this tension and the results of this test are shown in Figure 21. The material was unwound from a spool that incorporated a disc and spring-loaded calipers to cause resistance to rotation. The amount of tension in the roving was determined with a spring scale.

Vertical Wire Material. The basic test stand was configured as shown in Figure 22 to evaluate vertical slack wire material. The spool used to apply the tension to the Kevlar was positioned below the hub and the free end secured to the overhead cable. This position was selected for the spool because the material above the hub does not wrap around the pitch links. After the material was positioned, the motor was started. The results of the test are shown in Figure 23. The Kevlar wrapped approximately one turn around the pitch links and the remainder was coiled around the mast between the lower link attach plate and the upper test stand, which is the interface between the rotating and nonrotating system. This wrapping pattern is very similar to that experienced in the actual mishap shown in Figure 1. These results indicate that for material oriented vertically at contact the lower portion of the rotating controls will receive the majority of wrapped material. This fact is also suggested by the damaged swash-plate shown in Figure 2, which is located on the helicopter at the interface of the rotating and nonrotating portion of the controls.

#### Pitch Link Ring

Two tests were used to evaluate the pitch link ring concept for the protection it provided against vertical wire material. The first test used an identical method to introduce the Kevlar as in the baseline test and is shown in Figure 24. For the second test, the free end of the Kevlar was secured to the outboard portion of the hub instead of the overhead cable. The results of the first test are shown in Figure 25. The Kevlar was cut immediately after the motor was started. The results of the second test are shown in Figure 26. The Kevlar wound around the upper ends of the pitch links and was cut after approximately 30 seconds of hub rotation.

It was felt that the different cutting results of the two tests were related to the orientation of the Kevlar with respect to the cutting surface at the time cutting occurred.

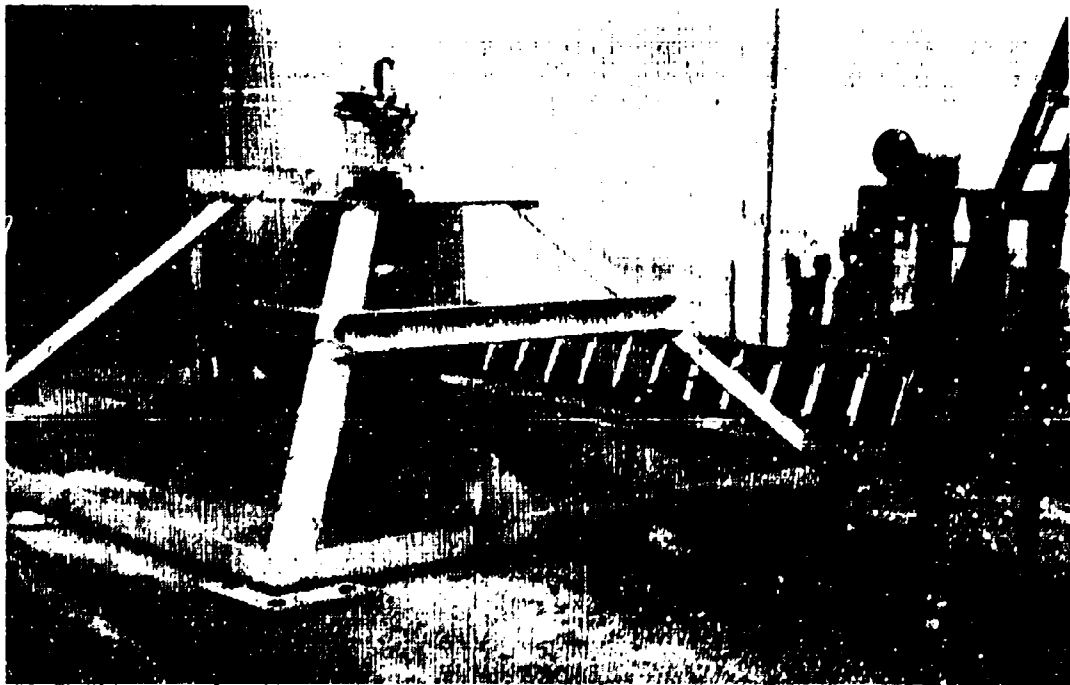
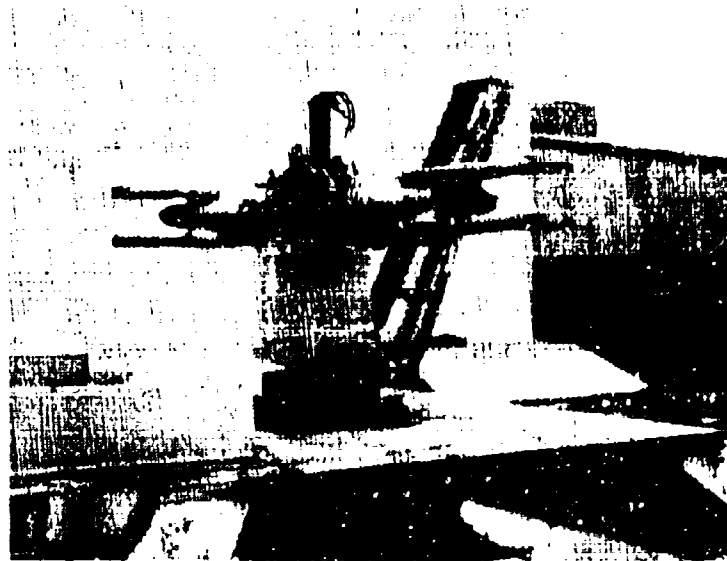

Figure 21. Horizontal wire baseline test.



Figure 22. Vertical wire baseline test setup.



Figure 23. Vertical wire baseline test results.

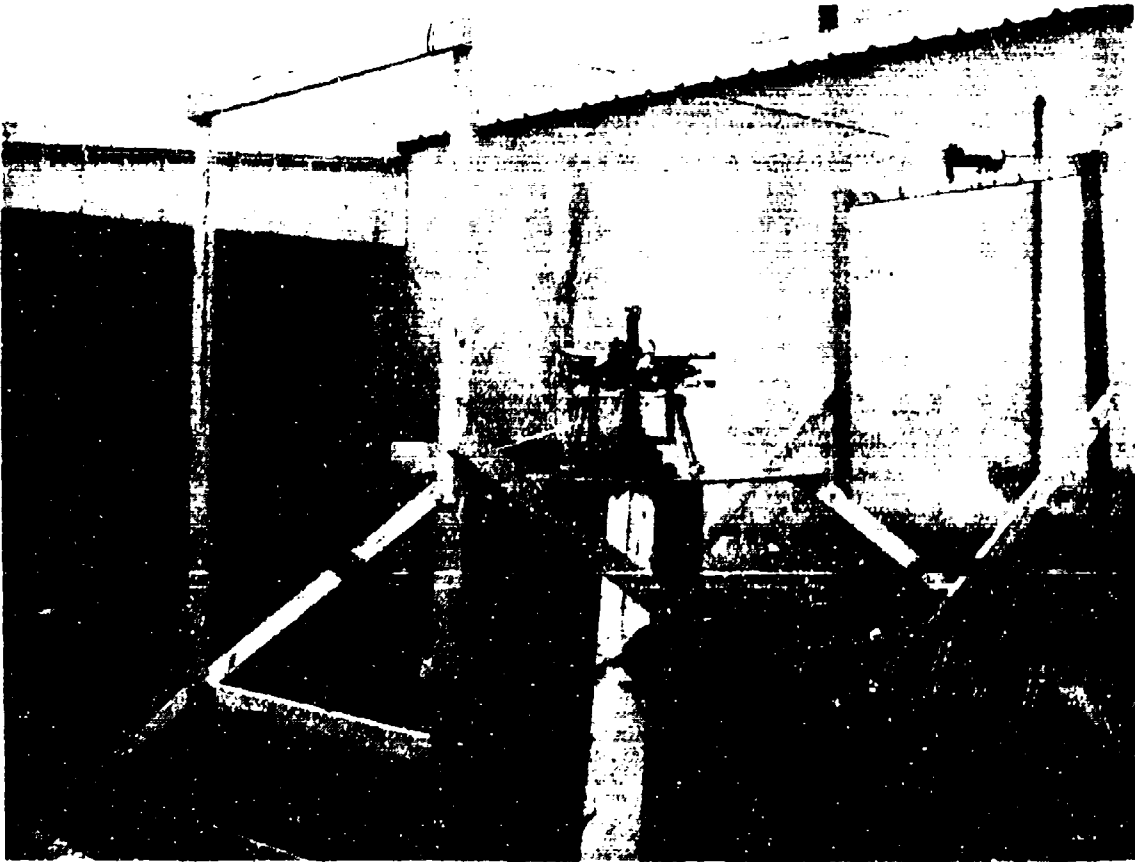
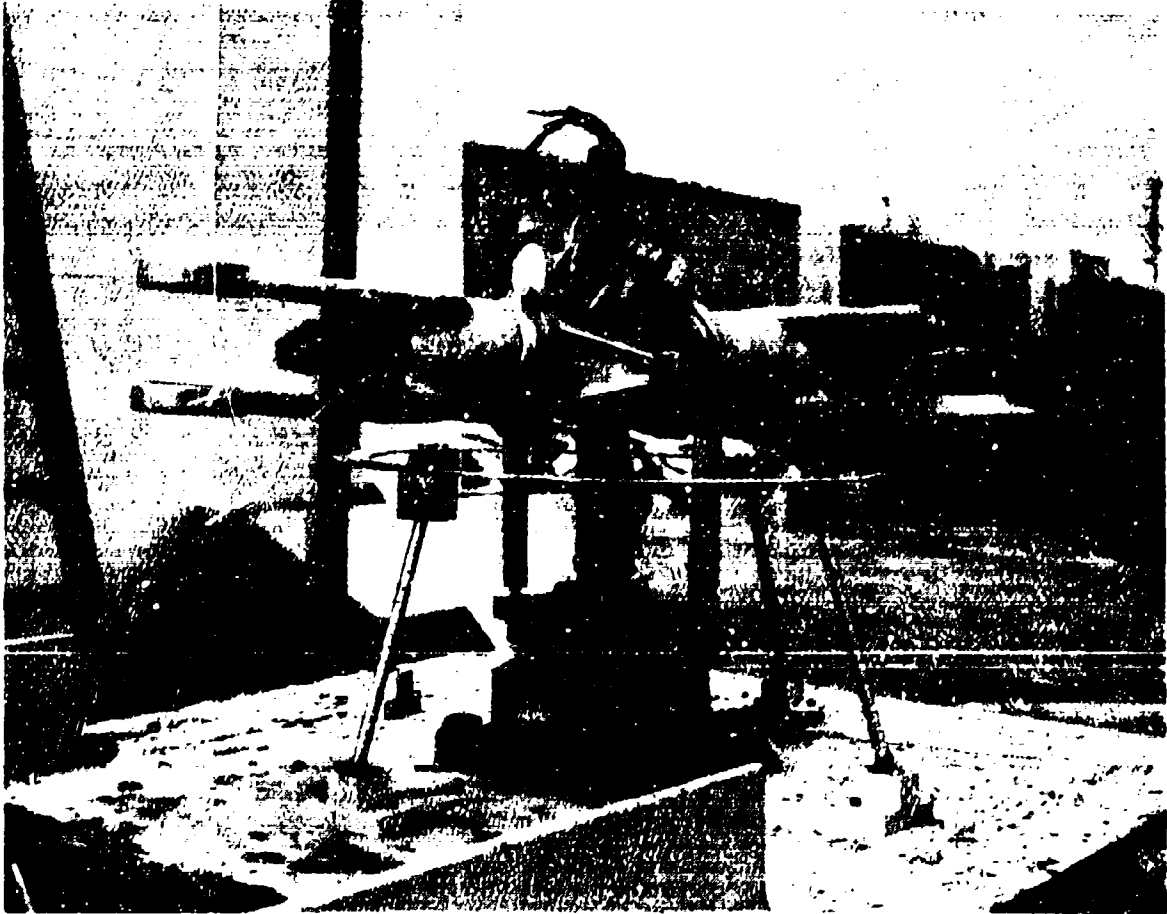

Figure 24. Pitch link ring test with baseline test setup.



11  
8

Figure 25. Test results of pitch link ring with baseline test setup.

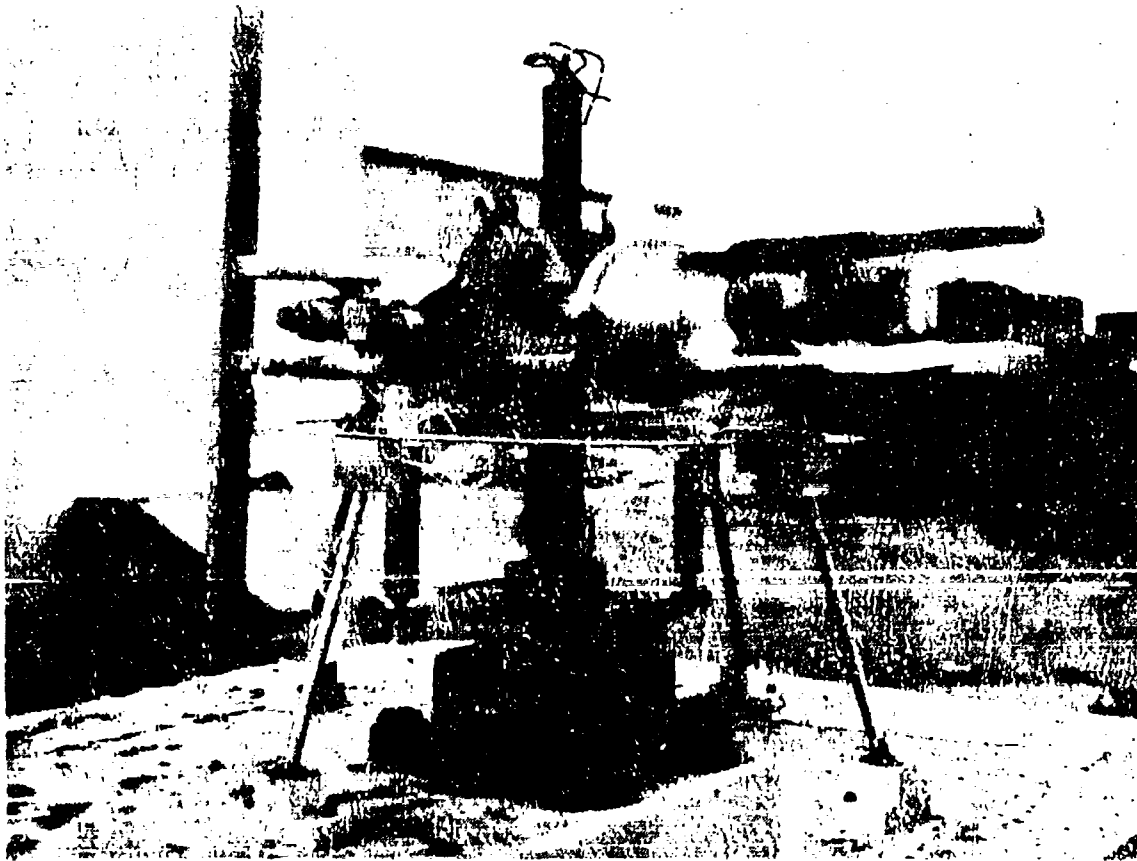

Figure 26. Test results of pitch link ring with modified test setup.

The Kevlar in the second test was secured on the hub outboard and above the cutting ring outer surface, and with hub rotation wrapped around the pitch links above the ring. As represented in Figure 27, the wrapping of the Kevlar around the pitch links caused it to slide over the cutting edge at an unfavorable orientation for efficient cutting. However, in the first test the Kevlar was forced inboard into the center of the hub at initial rotation and, as represented in Figure 28, formed a more vertical and efficient cutting angle.

The results of these tests would suggest that the cutting edge of the ring should be modified to cut material at any orientation.

#### Pitch Link Cutter

The standard test pitch links were removed and the pitch link cutters shown in Figure 18 were installed. The pitch link cutters were evaluated for wire material entering horizontally. Three types of wire material were tested - TOW wire, communication wire, and Kevlar roving for each of the cutter blade types, straight and sawtooth.

The wire material was introduced using the same method as discussed for the horizontal wire baseline test. For each test, the free end of the wire material being evaluated was secured to a pitch link and the motor then started. The straight blade cutter cut all three types of wire material immediately, not allowing any additional material to be wrapped around the pitch links. The sawtooth blade cut the Kevlar and TOW wire immediately but did not cut the communication wire.

The communication wire started filling in the notched area so that the wire was being wound on wire and the sharp edges were not contacted. This result was largely due to the lack of sharpness and configuration of the edge in the notched area. The sawtooth blade was smooth in the notched area and did not cut the wire on initial contact. It is felt that it would be premature to eliminate the sawtooth blade concept based on this test configuration without additional edge development. The sawtooth blade offers potential features that are discussed later in the report.

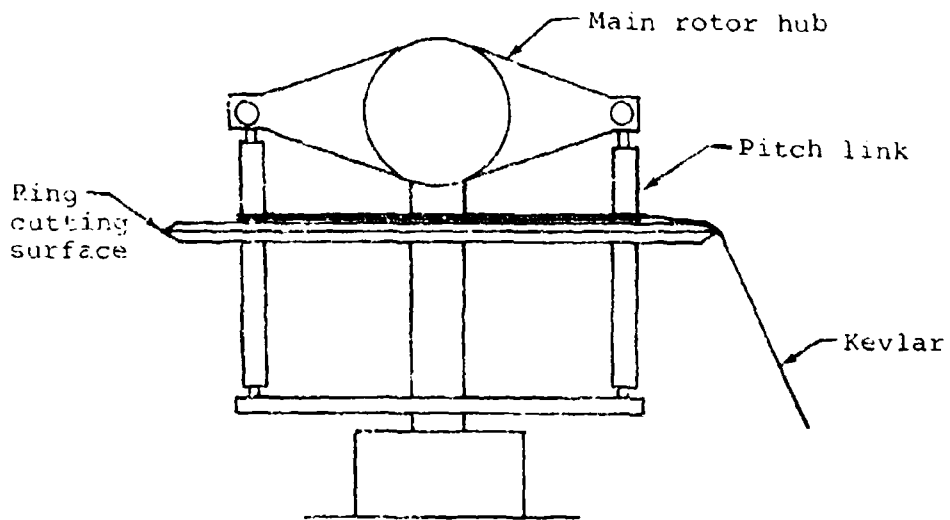

Figure 27. Kevlar orientation at cutting during modified test.

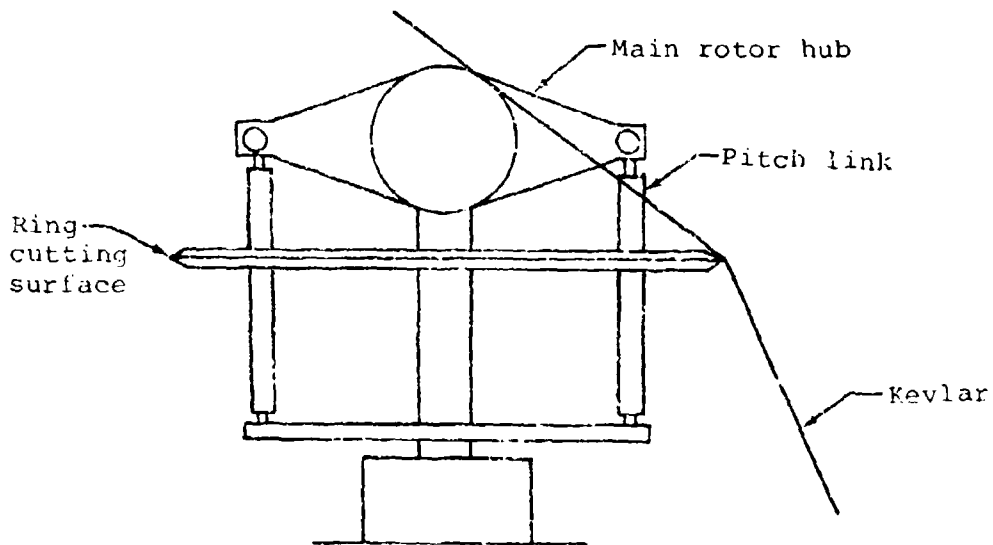

Figure 28. Kevlar orientation at cutting during baseline test.

## TRADE-OFF EVALUATION

After the concepts were refined during preliminary design, a trade-off evaluation was conducted to determine to what extent the desired characteristics were incorporated into each design. This was performed by establishing the important parameters and assigning a relative grade for each parameter. Comparisons between the concepts will be made qualitatively based on how their individual parameters are judged.

### PARAMETER DEFINITION

The individual parameters and methodology for establishing their relative ratings are described below.

Effectiveness. The effectiveness of a concept was considered to be a measure of how well it protects the rotor controls from bending or failing. Each concept was categorized as excellent, good, or marginal. An excellent rating applied to a concept that cut or shielded all types of slack wire from the entire control system. A good rating applied to a concept that was effective against most types of slack wire and/or protected most of the control system. A marginal rating applied to a concept that was effective against one type of slack wire and/or protected only one portion of the control system.

Weight. The weight of a concept is a function of its size, materials, attachment, and necessary modifications of the aircraft. The weight of a concept was characterized as negligible if there were no structural changes to the aircraft, there was minimal attachment hardware, and if the weight of the protection device was less than five pounds (e.g., sharp edges on the pitch links). A moderate rating applied when the device weighed over five pounds, attachment assemblies were required, and some structural changes to the aircraft were necessary. A significant rating applied when the device weighed over fifteen pounds and the basic structure of the aircraft required reinforcing.

Cost. The cost of a concept is a function of the parts count, materials, fabrication techniques, complexity, and modifications to the aircraft. A minimal cost rating applied when common materials were used, minimal changes

to the aircraft were red, and the device had few and simple parts. A moderate rating applied when the device complexity was appreciable and aircraft changes were required. A significant rating applied to a device that was complex, had an appreciable parts count, and required replacement or additional aircraft structure.

Retrofit Suitability. The suitability of a concept for retrofit on an OH-58 was rated as good or poor. A concept had good retrofit suitability if a minimum amount of modification was required for its installation and poor suitability if extensive helicopter changes were necessary.

UH-1 and AH-1 Adaptability. The adaptability of the OH-58 devised concept to UH-1 and AH-1 helicopters was rated as good or poor. A concept had good adaptability if the OH-58 concept could be used with little or no change and poor adaptability if major changes were required.

Dynamics. The effect of the concept on helicopter dynamic characteristics was rated as minimal or significant. The concept had a minimal effect on helicopter dynamics if the concept component natural frequencies were such that only occasional local vibrations resulted. The concept had a significant effect on helicopter dynamics if airframe or rotor frequencies were changed such that objectionable or damaging vibrations could result.

Structural. Helicopter structural effects of a concept were considered to be any increase in airframe or rotor component loads or decrease in existing structure strength due to its installation and were rated as being minimal, moderate, or significant.

Performance. Helicopter performance as described herein is construed as relating to static and dynamic handling qualities and power requirement changes due to a concept's increase in helicopter frontal and/or profile areas. These effects were rated as being minimal, moderate, or significant.

Maintainability. The impact of a concept on helicopter maintainability is a function of the interference that the concept will have on routine inspections and maintenance. Concepts that hide or prevent access to certain areas of the helicopter would include fairings or shields. Each concept was rated to have a minimal, moderate, or

significant effect on the overall helicopter maintainability.

Radar Cross Section. The amount of additional helicopter radar cross section attributable to a concept was considered to be a function of its size, location, and shape and was rated as minimal, moderate, or significant.

Personnel Hazard. The hazard presented by a concept was considered to be a function of the danger it presents to ground personnel. The amount of hazard present was rated as no hazard, some hazard, or very hazardous.

### CONCEPT COMPARISONS

To simplify the presentation of the relative grade of each concept, symbols were assigned to each of the parameter rating categories. These symbols and their meaning for each parameter are shown in Table 2.

The parameter ratings for each concept are shown in Table 3 for main rotor concepts and in Table 4 for tail rotor concepts. A description of the technical characteristics of each concept is given below, in which advantages and disadvantages of the design are discussed. Also, recommendations are made as to whether a concept should be rejected or further developed and tested.

#### Main Rotor Aerodynamic Fairings

The fairing offers protection for all but a small portion of the upper ends of the pitch links and a majority of the slack wire threats. However, vertical wire material encountered could become wrapped around the pitch links similar to that experienced during testing of the pitch link ring concept shown in Figure 29. For this reason, the effectiveness of the fairing received a "good" rating.

The operation of the helicopter is degraded due to the size and location of the fairing. Maintenance of the helicopter would be moderately affected because an additional cowling would have to be removed during scheduled maintenance. Also, more time would be required for preflight inspection of the rotating controls.

It is felt that the fairing would cause a significant degradation in performance and handling qualities of the helicopter.

TABLE 2. PARAMETER RATING SYMBOLS

PARAMETER	RATING SYMBOL MEANING		
	○	◐	●
Effectiveness	Excellent	Good	Marginal
Weight	Negligible	Moderate	Significant
Cost	Minimal	Moderate	Significant
Retrofitability	Good	-	Poor
UH-1 and AH-1 adaptability	Good	-	Poor
Dynamics	Minimal	-	Significant
Structural	Minimal	Moderate	Significant
Performance	Minimal	Moderate	Significant
Maintainability	Minimal	Moderate	Significant
Radar cross section	Minimal	Moderate	Significant
Personnel hazard	No hazard	Some hazard	Very hazardous

TABLE 3. MAIN ROTOR CONCEPT COMPARISON

	Effectiveness	Weight	Cost	Retrofittability	Adaptability	Dynamics	Structural	Performance	Maintainability	Radar Cross Section	Personnel Hazard
Aerodynamic fairing	●	○	○	○	○	○	○	○	○	○	○
Fairing and grip cutter	○	○	○	○	○	○	○	○	○	○	○
Pitch link ring	○	○	○	○	○	○	○	○	○	○	○
Pitch link ring and grip cutter	○	○	○	○	○	○	○	○	○	○	○
Actuated cutter	●	○	○	○	○	○	○	○	○	○	○
Pitch link cutter	○	○	○	○	○	○	○	○	○	○	○
Pitch link cutter and ring	○	○	○	○	○	○	○	○	○	○	○
Grip cutter	●	○	○	○	○	○	○	○	○	○	○

TABLE 4. TAIL ROTOR CONCEPT COMPARISON

	Effectiveness	Weight	Cost	Retrievability	Adaptability	Dynamics	Structural	Performance	Maintainability	Radar cross section	Personnel hazard
Controls cover	●	○	○	○	○	○	○	○	○	○	○
Controls cover and shaft cutter	○	○	○	○	○	○	○	○	○	○	○
Controls cover and shaft cover	○	○	○	○	○	○	○	○	○	○	○
Shaft cutter	●	○	○	○	○	○	○	○	○	○	○
Shaft cover	●	○	○	○	○	○	○	○	○	○	○
Yoke cutter	●	○	○	○	○	○	○	○	○	○	○
Pitch link cutter	●	○	○	○	○	○	○	○	○	○	○
Pitch link, shaft and yoke cutters	○	○	○	○	○	○	○	○	○	○	○

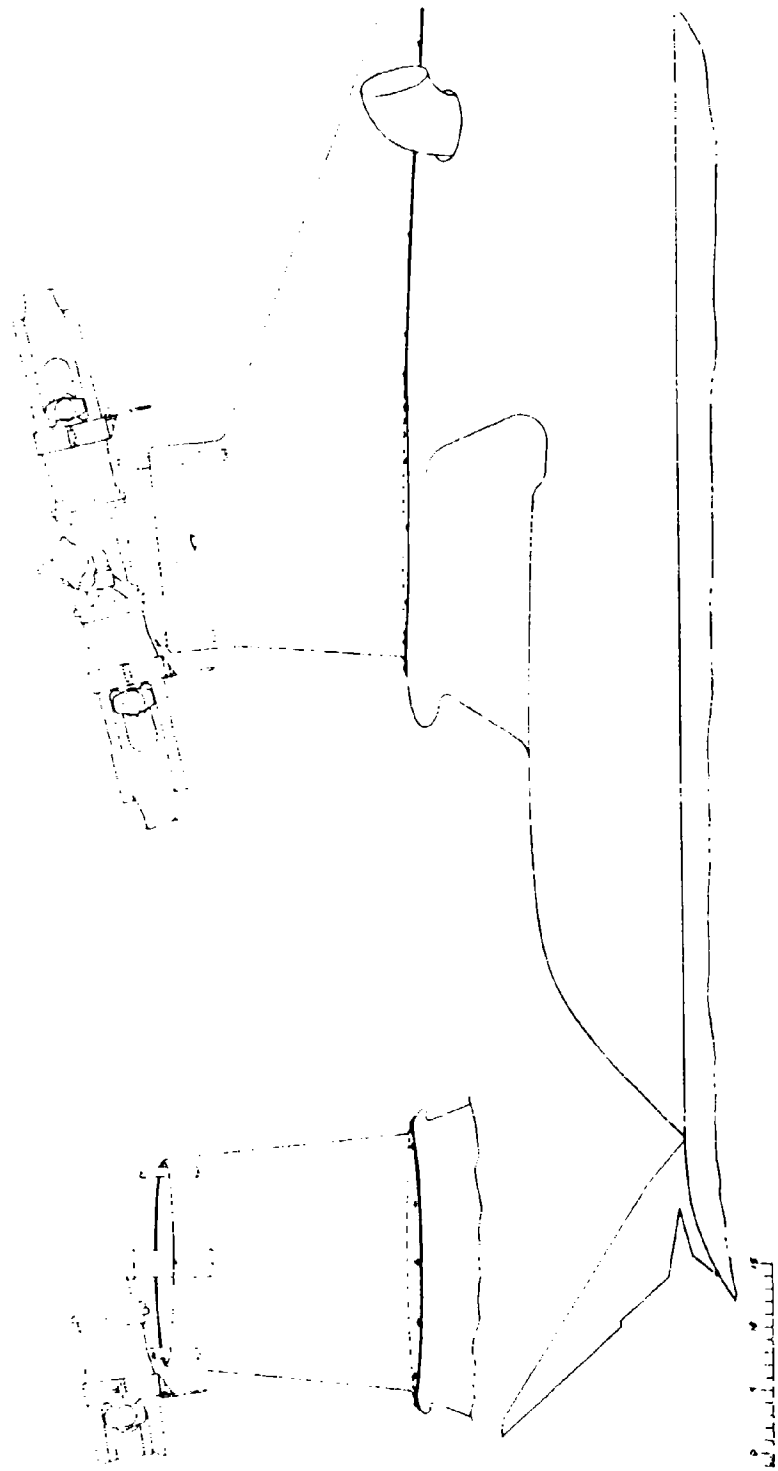

Figure 29. Main rotor aerodynamic fairing and grip-mounted cutter.

The additional cross-sectional area of the fairing would cause a reduction in the maximum attainable airspeed in level flight and a possible increase in turbulent airflow over the tail rotor and vertical fin. The actual performance and handling quality effects of the fairing would have to be evaluated in a flight test program.

The adaptability of the fairing was considered poor. The higher airspeed of the AH-1 helicopter and the greater distance between the rotor and fuselage on the UH-1 helicopter would possibly cause a greater degradation in performance and handling qualities than the OH-58 helicopter.

Variations in the fairing concept were considered to improve its overall rating. The grip assembly cutter was combined with the fairing, as shown in Figure 30, to protect the upper portion of the pitch links. The effectiveness of the system is considered to be excellent, but the cutter added an additional degree of hazard and degraded the operation of the helicopter. The fairing shape and helicopter configuration could be developed during a flight test program to improve or to correct the reduced performance and handling qualities; however, it would be expensive and have a risk associated with it. It was felt that the excellent effectiveness of the fairing system did not offset its known deficiencies and potentially high development cost and, therefore, should not be considered a viable concept.

#### Main Rotor Pitch Link Ring

The feasibility and effectiveness of the pitch link ring was successfully demonstrated during testing. The concept has the potential of excellent protection for the pitch links and swashplate from wire material oriented vertically. Protection from horizontal (parallel to swashplate rotation plane) wire material would be good with a small portion of the upper pitch links exposed. Marginal protection would be offered for material encountered parallel to the centerline of the helicopter.

The concept is lightweight, low in cost, and has minimal effect on helicopter operation. Installation of the design is simple, and retrofitability and adaptability would be good.

The structural strength and stiffness of the support tubes would have to be evaluated during additional development testing. Any possible threats should be identified that might cause high loads and deflect the ring into the rotating controls.

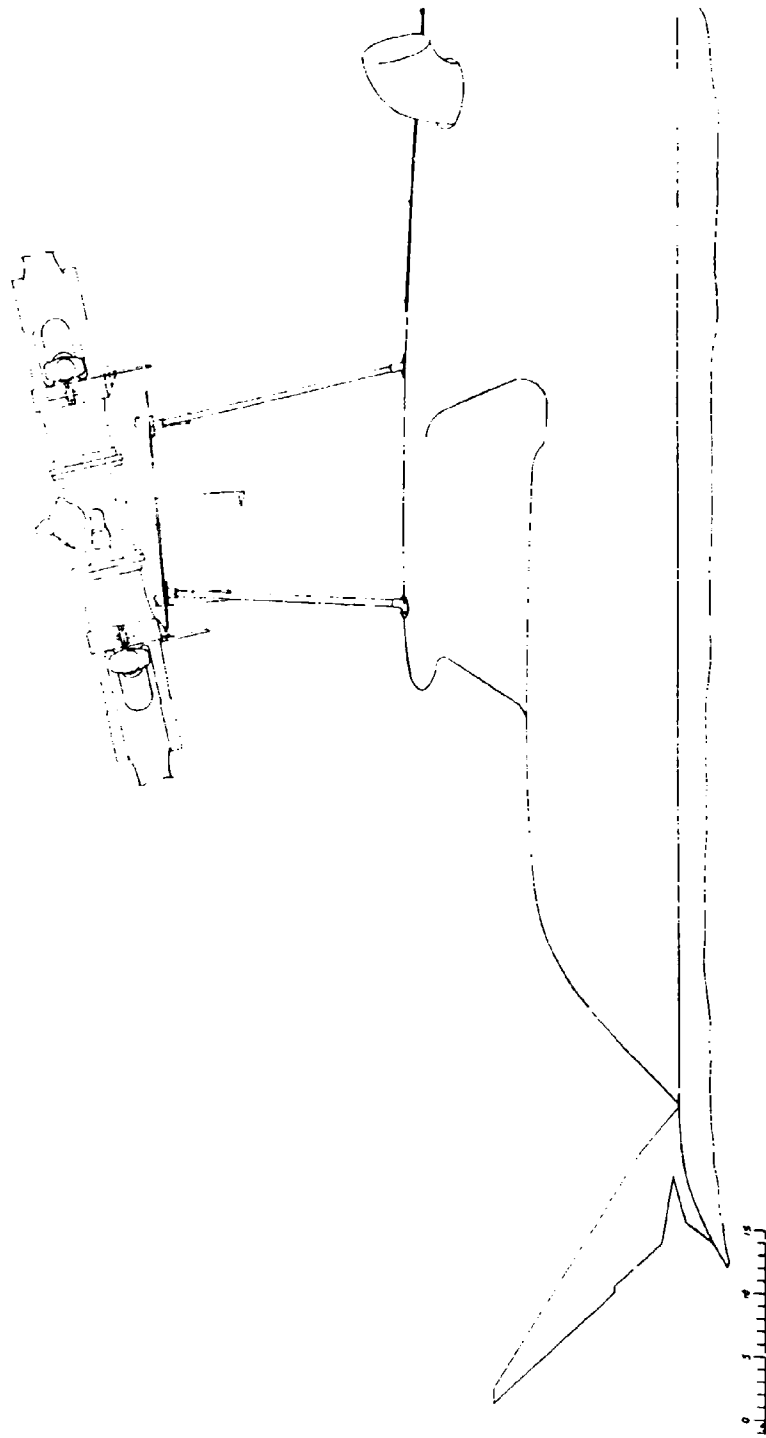

Figure 30. Main rotor pitch link ring and grip-mounted cutter.

Variations in the concept were considered to improve its overall rating. The grip assembly cutter was combined with the pitch link ring to protect the upper portion of the pitch links and is shown in Figure 30. The effectiveness of the resulting system would be excellent for vertical and horizontal threats and would not significantly affect the other parameters.

The pitch link ring concept and its variation are both promising concepts and should be developed and tested further.

#### Main Rotor Actuated Cutter

The effectiveness of the shear cutter or reciprocating cutter would be marginal. Protection from horizontal (perpendicular to helicopter centerline) wire material would be good. Horizontal wire that draped and trailed across the upper guide blade could become entangled in the pitch links before the tension in the wire became sufficient to cause cutting on the sharp guide. The cutters would offer marginal protection against vertically oriented material or material aligned with the helicopter centerline. The cutter would be effective for those cases in which vertical wire material was caught on the hub and rotated forward of the guide blade and across it. For cases similar to those tested in which the material was forced into the center of the hub, the cutter would be useless.

Additional design development would be required to define the internal mechanism of the rams and electrical installation. The design would involve modifications to airframe structure and electrical panels and make retrofit complicated. The mechanism would require periodic lubrication and cleaning and pose a serious hazard to ground personnel.

It is felt that the effectiveness of the actuated cutters does not offset the other major deficiencies and, therefore, should not be considered a viable concept.

#### Main Rotor Pitch Link Cutters

The feasibility of cutting slack wire as it wraps around the rotating controls was successfully demonstrated during testing. These results are discussed on page 58. All materials identified for testing were cut. The concept offers excellent protection from horizontal wire material and has the potential of excellent protection from vertical wire material.

The concept is lightweight, low in cost, and has minimal effect on helicopter operation. Installation of the design is simple, and retrofitability and adaptability would be good. The sharp edges could be covered with a simple sheath to protect ground and maintenance personnel from injury.

The contribution of the forward blade to the overall effectiveness of the pitch link cutters was not tested. The forward blade installation is a major portion of the concept weight, and additional testing could establish if the change in effectiveness it provided was worth the weight and cost penalty. The forward blade in some cases could provide the necessary tension required for cutting vertical or horizontal wire materials by the pitch link cutters. Horizontal wire that became draped over the forward blade and wrapped around the rotating controls could be cut by its edge or the pitch link blade. The forward blade would also be effective for those cases in which vertical wire material was caught on the hub and rotated forward of the blade wrapping around it and the pitch links.

Additional development of the sawtoothed pitch link blade shape could improve cutting effectiveness on thicker diameter and vertical wire materials. As shown in Figure 31, the selected angle of the sawtooth blade could cause relative motion between the cutting surface and the wire material as it wrapped and cut more efficiently. The blade edge shape tested for the sawtooth configuration was less refined than the straight blade edge. Cutting efficiency of the sawtoothed blade could also be improved if a cutting edge similar to the straight blade were used in the notched area.

Variations of the pitch link cutter concept should be evaluated during additional testing. Swashplate protection for vertical wire material could be improved by adding a low pitch link ring concept. The 3- to 4-inch-tall ring would either cut the wire or redirect the wire to the pitch link cutter edge at a more favorable orientation for cutting.

#### Grip Assembly Cutter

The grip assembly cutter concept as discussed earlier was primarily used in conjunction with other concepts to form a protection system. As an individual concept, the grip cutter would have poor overall effectiveness; however, when combined with other concepts, it offers excellent protection for the

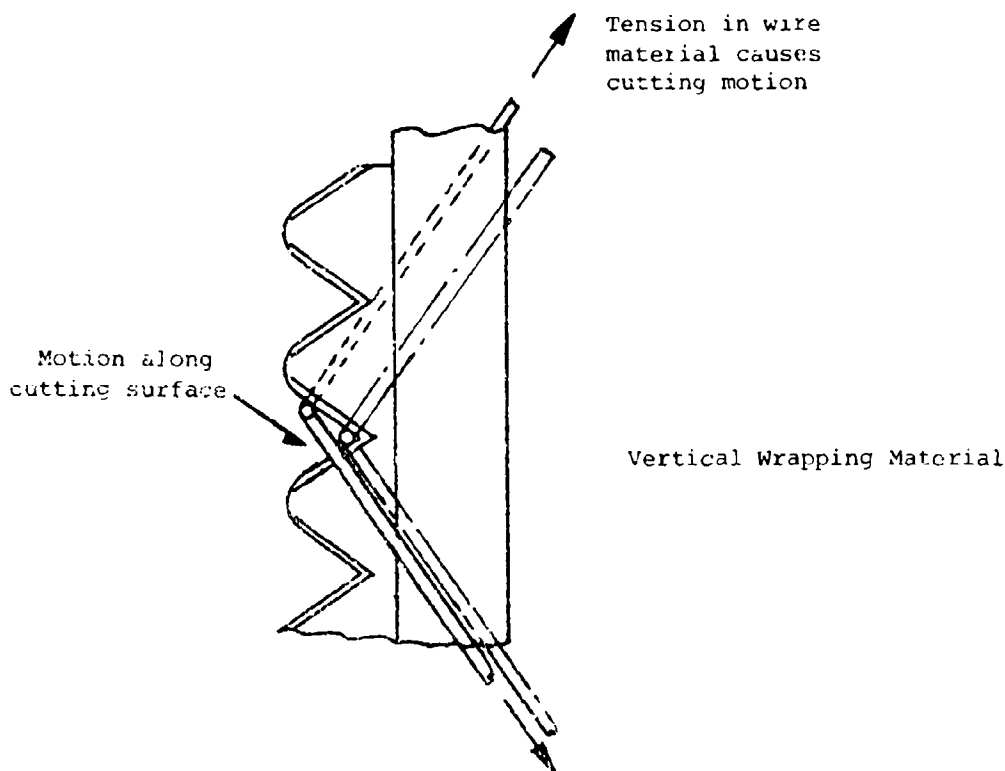
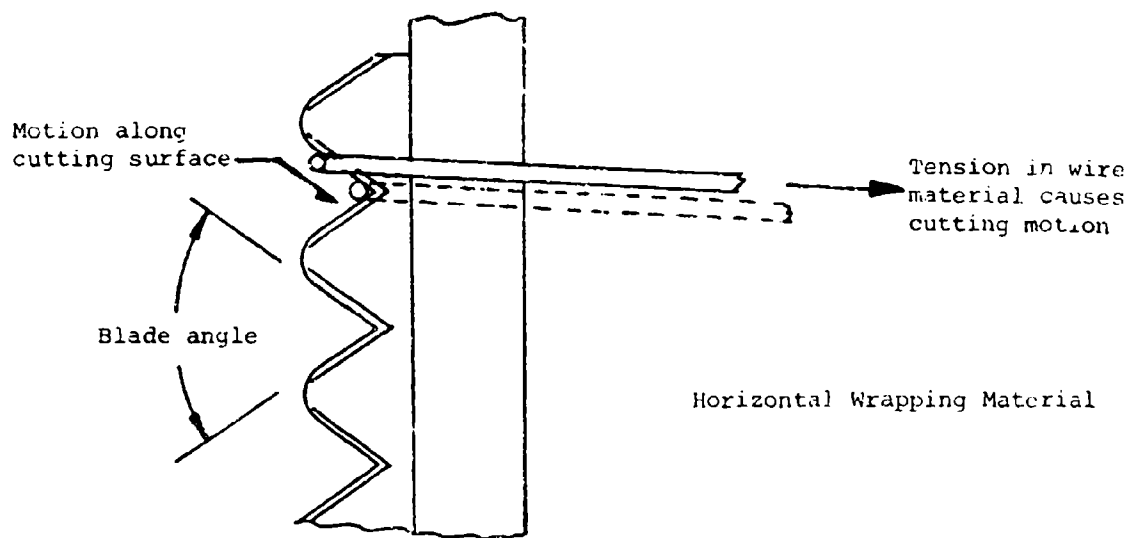

Figure 31. Effect of pitch link cutter blade shape on cutting motion.

upper pitch links against all threats. The blades are angled such that wire material would not collect and bind the feathering axis of the blade.

The cutters are lightweight, low in cost, and have minimal effect on helicopter operation. Installation of the design is simple, and retrofitability and adaptability would be good. The sharp edges could be covered with a simple sheath and strap to protect ground and maintenance personnel from injury.

The grip cutters as an individual concept should be rejected but should be considered in the development and testing of other concepts.

#### Tail Rotor Controls Cover

The tail rotor controls cover would offer excellent protection for the pitch change mechanism against all threats. However, material can become wrapped around the shaft and have adverse effects on tail rotor flapping. For this reason, the overall effectiveness was considered to be only good.

The weight and cost of the cover would be moderate. The weight calculations for all tail rotor concepts included the ballast adjustments required at the nose to keep the center of gravity of the helicopter unchanged with the concepts installed.

Maintainability of the helicopter is moderately affected because additional covers would have to be removed during scheduled maintenance, more time would be required for pre-flight inspection of the pitch change mechanism, and tail rotor balancing would require more time.

13  
B

Variations in the cover concept were considered to improve its overall rating. Either the shaft cutter or the shaft cover would combine with the controls cover to protect the area between the gearbox and the yoke. The effectiveness of the resulting system was considered to be excellent and not detrimental to the other parameters.

The tail rotor cover and its variations are all promising concepts and should be developed further.

#### Tail Rotor Shaft Cutter and Shaft Cover

The shaft cutter and shaft cover concepts as discussed earlier were primarily used in conjunction with other concepts to form

a protection system. As individual concepts, the shaft cutter and shaft cover would each have poor overall effectivity. But, when combined with other concepts, they offer excellent protection for the area between the gearbox and the yoke.

The cover and cutter are each lightweight, low in cost, and have minimal effect on helicopter operation. Installation of the designs is simple, and retrofitability and adaptability would be good.

The shaft cutter and shaft cover as individual concepts should be rejected but should be considered in the development and testing of other concepts.

#### Tail Rotor Yoke Cutters

The yoke cutter would have marginal overall effectiveness. It would provide excellent protection for the pitch change bearings and the ends of the yoke. However, little protection would be offered the pitch change mechanism.

Although the cutters are lightweight and low in cost, they could cause a moderate increase in pilot effort. The added weight of the cutters on the pitch arm ring would combine with the existing balance weights to cause an increase in pedal forces and more pitch link bearing wear. These effects could be minimized by additional design and analysis.

The adaptability of the cutters is poor because the design would have to be significantly modified for use on UH-1 and AH-1 helicopters.

The yoke cutter would require a moderate amount of additional development, but it offers the potential of excellent protection for the pitch change bearing area. It could be used in conjunction with other concepts to improve overall effectiveness and, for this reason, the yoke cutters should be developed and tested further.

#### Tail Rotor Pitch Link Cutters

The pitch link cutter would have marginal overall effectiveness. It would provide excellent protection for the pitch change mechanism but little protection for the pitch change bearings and yoke ends.

The concept is lightweight, low in cost, and has minimal effect on helicopter operation. Installation of the design is simple, and retrofitability and adaptability would be good. The sharp edges could be covered with a simple sheath to protect ground and maintenance personnel from injury.

Variations in the pitch link cutter concept were considered to improve its overall effectiveness. The yoke end shaft cutters were combined with the pitch link cutters to form a system that could provide excellent overall protection with minimal effect on weight and cost.

The pitch link cutter as an individual concept should be rejected but should be considered in the development and testing of other concepts.

## CONCLUSIONS

The two most promising wire protection concepts selected for full-scale testing were the pitch link ring and pitch link cutters. Two pitch link cutter configurations were tested. Three types of wire material, aligned vertically and horizontally, were tested. It was demonstrated by these tests that both concepts could cut wires before a disastrous buildup could form. In addition to validating the concepts, the tests disclosed some useful information regarding the behavior of the wires during different encounter situations.

## RECOMMENDATIONS

Based on the results of this effort, it is recommended that:

1. The following concepts be fabricated and tested.

For main rotor protection:

- Pitch link ring
- Pitch link ring with grip cutters
- Pitch link cutters
- Pitch link cutters with modified pitch link ring

For tail rotor protection:

- Controls cover
- Controls cover with shaft cutter
- Controls cover with shaft cover
- Pitch link cutter with shaft cutter and yoke cutter

2. The functional testing of the main rotor protection devices continue and expand in scope to include all actual rotating hardware and measurements of the non-rotating input control forces.
3. The functional testing of the tail rotor protection devices include all actual rotating hardware (including blades) and measurements of the nonrotating input control forces.