

AD-A116 900

FEDERAL AVIATION ADMINISTRATION TECHNICAL CENTER ATL--ETC F/6 5/5  
DEVELOPMENT OF SUPERVISOR DESK MODULES FOR TERMINAL RADAR APPRO--ETC(U)  
JUL 82 F F HIERBAUM, P ZITO, T E ZURINSKAS

UNCLASSIFIED

DOT/FAA/CT-82/50

DOT/FAA/RD-82/59

NL

(of 1)  
A116900

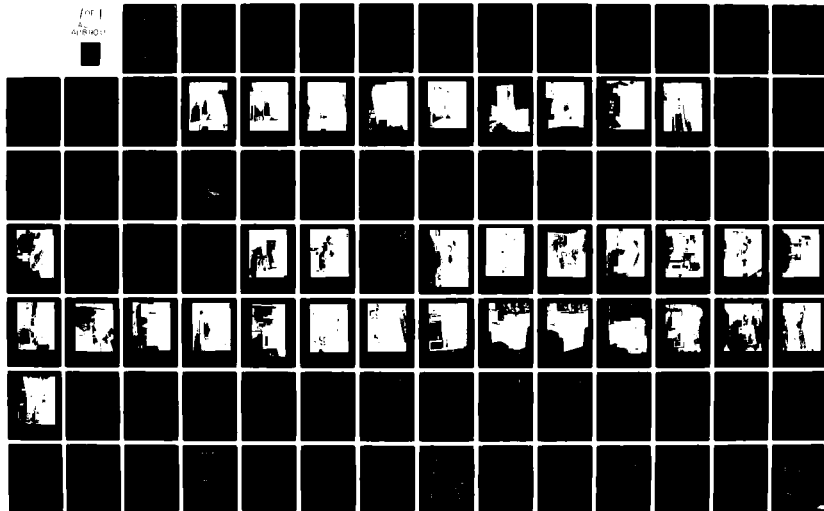

12

DOT/FAA/RD-82/59  
DOT/FAA/CT-82/50

# Development of Supervisor Desk Modules for Terminal Radar Approach Control (TRACON) Facilities

AD A118900

Felix F. Hierbaum  
Paul Zito  
Thomas E. Zurinskas

Prepared by  
FAA Technical Center  
Atlantic City Airport, N.J. 08405

July 1982

Final Report

This document is available to the U.S. public  
through the National Technical Information  
Service, Springfield, Virginia 22161.

DTIC FILE COPY



U.S. Department of Transportation  
Federal Aviation Administration  
Systems Research & Development Service  
Washington, D.C. 20590

DTIC  
SEP 03 1982  
E

086

**NOTICE**

**This document is disseminated under the sponsorship of the Department of Transportation in the interest of information exchange. The United States Government assumes no liability for the contents or use thereof.**

**The United States Government does not endorse products or manufacturers. Trade or manufacturer's names appear herein solely because they are considered essential to the object of this report.**

Technical Report Documentation Page

1. Report No. DOT/FAA/RD-82/59	2. Government Accession No. AD-A118 900	3. Recipient's Catalog No.	
4. Title and Subtitle  DEVELOPMENT OF SUPERVISOR DESK MODULES FOR TERMINAL RADAR APPROACH CONTROL (TRACON) FACILITIES		5. Report Date July 1982	
		6. Performing Organization Code	
7. Author(s) Felix F. Hierbaum, Paul Zito, and Thomas E. Zurinskas		8. Performing Organization Report No. DOT/FAA/CT-82/50	
9. Performing Organization Name and Address Federal Aviation Administration Technical Center Atlantic City Airport, New Jersey 08405		10. Work Unit No. (TRAIS)	
		11. Contract or Grant No. 144-170-830	
12. Sponsoring Agency Name and Address U.S. Department of Transportation Federal Aviation Administration Systems Research and Development Service Washington, D.C. 20590		13. Type of Report and Period Covered  Final Sept. 1978 to Sept. 1981	
		14. Sponsoring Agency Code	
15. Supplementary Notes			
16. Abstract  The purpose of this report is to document the quest for standard supervisor desks in air traffic control (ATC) Terminal Radar Approach Control (TRACON) rooms. Several prototype designs were studied, and a seminar was held to resolve equipment constraints. Modular desk segments which could be arranged to form multiple desk configurations were developed as a result of this investigation.			
17. Key Words Air Traffic Control Terminal Radar Desk Design Furniture Design		18. Distribution Statement Document is available to the U.S. public through the National Technical Information Service, Springfield, Virginia 22161	
19. Security Classif. (of this report) Unclassified	20. Security Classif. (of this page) Unclassified	21. No. of Pages 82	22. Price

### METRIC CONVERSION FACTORS

Approximate Conversions to Metric Measures		Approximate Conversions from Metric Measures		
Symbol	When You Know	Multiply by	To Find	Symbol
<b>LENGTH</b>				
in	inches	2.5	centimeters	mm
ft	feet	30	centimeters	cm
yd	yards	0.9	meters	m
mi	miles	1.6	kilometers	km
<b>AREA</b>				
sq ft	square feet	0.5	square centimeters	cm <sup>2</sup>
sq yd	square yards	0.8	square meters	m <sup>2</sup>
sq mi	square miles	0.5	square kilometers	km <sup>2</sup>
acres	acres	2.5	hectares	ha
<b>MASS (weight)</b>				
oz	ounces	28	grams	g
lb	pounds (2000 lb)	0.45	kilograms	kg
		0.5	tonnes	t
<b>VOLUME</b>				
cup	teaspoons	5	milliliters	ml
fl oz	tablespoons	15	milliliters	ml
c	fluid ounces	30	milliliters	ml
pt	cup	0.24	liters	l
qt	quarts	0.47	liters	l
gal	gallons	0.95	liters	l
cu ft	cubic feet	3.8	liters	l
cu yd	cubic yards	0.80	cubic meters	m <sup>3</sup>
		0.76	cubic meters	m <sup>3</sup>
<b>TEMPERATURE (exact)</b>				
°F	Fahrenheit temperature	5/9 (after subtracting 32)	Celsius temperature	°C

Approximate Conversions from Metric Measures		Approximate Conversions to Metric Measures		
Symbol	When You Know	Multiply by	To Find	Symbol
<b>LENGTH</b>				
in	inches	0.04	millimeters	mm
in	inches	0.4	centimeters	cm
ft	feet	3.3	meters	m
yd	yards	1.1	meters	m
mi	miles	0.6	kilometers	km
<b>AREA</b>				
sq in	square inches	0.16	square centimeters	cm <sup>2</sup>
sq ft	square feet	1.2	square meters	m <sup>2</sup>
sq yd	square yards	0.5	square kilometers	km <sup>2</sup>
acres	acres	2.5	hectares (10,000 m <sup>2</sup> )	ha
<b>MASS (weight)</b>				
ounce	ounces	0.028	grams	g
pounds	pounds	2.2	kilograms	kg
short tons	short tons	1.1	tonnes (1000 kg)	t
<b>VOLUME</b>				
fluid ounces	fluid ounces	0.03	milliliters	ml
quarts	quarts	2.1	liters	l
gallons	gallons	1.08	liters	l
cubic feet	cubic feet	0.28	liters	l
cubic yards	cubic yards	36	cubic meters	m <sup>3</sup>
		1.3	cubic meters	m <sup>3</sup>
<b>TEMPERATURE (exact)</b>				
°F	Fahrenheit temperature	9/5 (then add 32)	Celsius temperature	°C

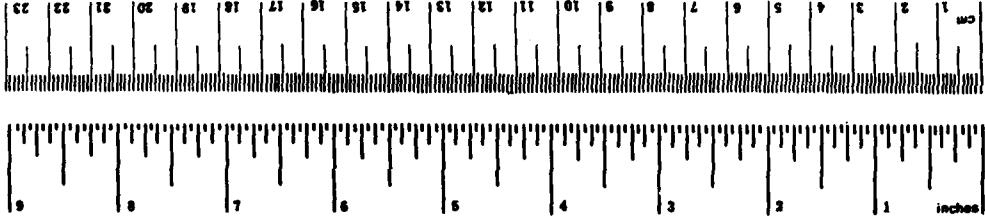

\*1 in = 2.54 exactly. For other exact conversions and more detailed tables, see NBS Misc. Publ. 286, Units of Length and Measures, Price \$2.25, SD Catalog No. C13.10.286.

TABLE OF CONTENTS

	Page
INTRODUCTION	1
Purpose	1
Background	1
DISCUSSION	1
General	1
Methodology	1
Field Evaluation Results	2
SEMINAR ON SUPERVISOR DESKS	3
MODULAR SUPERVISOR DESK CONCEPT DEVELOPMENT	4
Overall Aspects of Modular Desk	5
Construction Details of the Modular Desk	7
CONCLUSIONS	7
RECOMMENDATION	8
APPENDICES	
A - Field-Implemented Supervisor Desk Designs	
B - Drawings as Proposed for Modular Supervisory Desks	
C - Detailed Drawings of the Final Supervisor Desk Modular Design	



Accession For	
DTIC GRA&I	<input checked="" type="checkbox"/>
DTIC TAB	<input type="checkbox"/>
Unannounced	<input type="checkbox"/>
Distribution/	
Avail. and/or Codes	
Dist. Special	
A	

## LIST OF ILLUSTRATIONS

Figure		Page
1	Supervisor Desk Modules	9
2	Main Console (A)	10
3	Main Console with Bookcase and Dimmer (A')	11
4	Main Pedestal (B) and 90° Corner Console (C)	12
5	Typewriter Console (D) and Typewriter Pedestal (E)	13
6	45° Corner Console (F)	14
7	Storage Console (G) and Bookcase (H)	15
8	Front View of Attached Modules	16
9	Back View of Attached Modules	17
10	View of Wire Runs and Outlets Behind Turret	18
11	Supervisor Desk Area for 5,000 sq. ft. TRACON Building	19
12	Supervisor Desk Area for 8,000 sq. ft. TRACON Building	20
13	Supervisor Desk Area for 11,000 sq. ft. TRACON Building	21
14	Supervisor Desk Area for 14,500 sq. ft. TRACON Building	22
15	Supervisor Desk Area for 20,000 sq.ft. TRACON Building	23
16	Supervisor Desk "J" Configuration	24
17	Supervisor Desk "Big L" Configuration	25
18	Supervisor Desk "Little L" Configuration	26
19	Supervisor Desk In-Line Configuration	26
20	Various Configurations for Same Room Size	27

## INTRODUCTION

### PURPOSE.

The purpose of this report is to document the development of standards for supervisor desks for use in standard sized Terminal Radar Approach Control (TRACON) rooms in the air traffic control (ATC) environment. These desks were developed as project work at the Federal Aviation Administration (FAA) Technical Center, and many are currently utilized at various field facilities.

### BACKGROUND.

The object of the supervisor desk project has always been standardization. An evaluation, after completion of an early prototype design of a standard model desk, was accomplished by the Technical Center, FAA Headquarters, and Regional personnel in November 1979. This evaluation established that one standard console design could not meet the needs of all the various sizes and configurations of TRACON rooms.

In light of this, a research, development, and engineering effort request was submitted by Airway Facilities Service (AFS) and approved by Systems Research and Development Service (SRDS) which directed the Technical Center to develop a supervisor desk or series of desks that would fit into the five existing Level I-V TRACON room designs. It was during this effort that the modular concept was conceived and developed.

## DISCUSSION

### GENERAL.

This report delineates the development of standardized supervisor desk modules that could be reconfigured to allow various configurations in shape and size to accommodate the five existing TRACON designs. The design of these modules was derived through an evolutionary evaluative process that resulted in the construction of several unique operational desks which were subsequently installed at field facilities.

### METHODOLOGY.

As requests for supervisor desks were received from various facilities, their design and construction attempted to take advantage of improvements which were made in previous models. After the desks were installed at the field facilities, they were evaluated by facility personnel. The results of these evaluations generated changes in future desk models. Examples of these desks can be found in appendix A.

The method by which each desk was developed was the same in all cases. First, anthropomorphic data were applied using "Human Engineering Design Criteria for Military Systems, Equipment and Facilities" (revised May 10, 1978) as a guide.

The requesting facility was visited, and its personnel were consulted to assure feasibility of design. Next, a foamcore mockup of the console was constructed and evaluated at the Technical Center to determine suitability. Finally, the final wood and formica desk was constructed in sections at the Technical Center and shipped to the site for assembly. Appendix A describes the development of all of the supervisory desks designed under this program.

The same methodology was used in the development of the supervisory desk modules. Anthropomorphic criteria were applied to design drawings. Past experience with previous designs was also applied, as well as information received from facility personnel concerning their particular desks. A seminar was conducted at the Technical Center that provided input on present and future needs which would affect the design of a supervisor desk. The seminar is documented in "Proceedings of the 1979 Seminar on Air Traffic Control Terminal Radar Approach Control (TRACON) Facility Supervisory Desk Complex" (FAA-RD-80-105, August, 1980). The seminar is discussed briefly in this report.

Having applied all of these considerations to the design of the modular supervisor desk, a foamcore model was constructed for evaluation by SRDS and AFS personnel. After the evaluation of the foamcore mockup, a final wood and formica prototype of each module was constructed and placed in the Technical Center Configuration Laboratory for display and demonstration. This prototype is recommended as the standard design, and it can be adapted to most, if not all, existing TRACON facilities.

#### FIELD EVALUATION RESULTS.

A detailed description and photographs of the twelve desks built for this project and installed at field facilities can be found in appendix A. A brief description follows:

**ATLANTIC CITY.** This design was not an attempt at a standard but rather a test of team capabilities in designing and constructing its first desk to meet a unique situation. The front part of the desk meets the supervisor needs, while the back part meets the needs of the flight data position. The result was a desk that succeeded in organizing the dual workspace area while proving out team capabilities.

**TALLAHASSEE.** This desk expanded a present metal secretary's desk by adding a raised wooden portion, or turret, and file drawers. This was the first desk to use turret task-lighting.

**DENVER.** The Denver desk was a first attempt toward a standard "L" shaped desk. A vast improvement over the previous desk at Denver, it showed several considerations that subsequently were born out in later desks; i.e., the need for adequate typewriter carriage return space, bulb replacement facilitation, drawer stoppers at back for strength, light dimmer location at nonimpact areas, and increased desk-top lighting.

**WINDSOR LOCKS.** This desk was an attempt at a minimum size, "U" shape one-man desk. Subsequent evaluation indicated that this desk proved too confining. The pullout typewriter and drawers interfered with the seating area. The inserted Conrac display was not ventilated properly. The writing surface, as well as dimmer switch location, area was inadequate.

FUTURAMA. Incorporating much of what was learned from preceding desks, the Futurama desk was designed for maximum size, level V, two-man operation. At the time it was judged too grandiose, but later experience in the project has developed a level V design almost as large.

COLORADO SPRINGS. The desk at Colorado Springs did much to coordinate the area at the facilities. One innovation at their request was a slotted forms storage console. Again, the light dimmer location and typewriter space were inadequate.

BALTIMORE. This desk was formerly the right side of the cannibalized "Futurama" desk previously mentioned. Overhead framing lights were used to augment desk lights. A section was added to the "L" to make a "U" shaped desk. A problem was discovered with knee room in the corner between sections.

DULLES. This desk was cannibalized from the left side of the Futurama desk. It was suitable for a two-man operation. Full use of the turret area was made.

SOUTH BEND. This desk was an updated version of the Denver desk for a level III facility. It incorporated new placement for the dimmer switch and expanded typewriter area. Initial opinion was that the desk was too big for the level III facility, but later it was termed adequate.

CHARLOTTE. The Charlotte desk was a mirror image of the South Bend desk.

BURBANK. This desk utilized a slotted-form storage pedestal and slanted light baffle which allowed more light to be cast on the writing surface. The light dimmer was turret mounted.

PHILADELPHIA. This was the large level V desk. It had several distinguishable sections: a storage section with a two-story bookcase; a 45° corner section suitable for a typewriter or input/output keyboard; a slanted light baffle extending over the writing surface; turret-mounted light dimmers, and an expanded typewriter area with pedestal of slotted form bins. This desk was approximately the same size as the Futurama desk and was judged adequate by facility personnel.

#### SEMINAR ON SUPERVISOR DESKS

A seminar was conducted at the FAA Technical Center to derive input from field facilities, Systems Research and Development Service, Airway Facilities Service, and Air Traffic Service relative to the equipment requirements and design concepts for supervisors desks. A report of the proceedings was published in August 1980 (Report No. FAA-RD-80-105).

SEMINAR CONCLUSIONS. It was concluded from the results of the workshop and the reports presented, that the supervisory desks designed and developed by the Technical Center have vastly improved the supervisory complex and operational environments where they were installed. These desks have established the validity of modular design (as opposed to one-piece construction), task lighting, plywood construction, nonreflective finish, accessibility for maintenance and installation of equipment, forms and file storage drawers, and a specifically designed typewriter location.

**SEMINAR RECOMMENDATIONS.** It was recommended by those attending the seminar that the current supervisor desk evaluation be extended by the Technical Center for 2 years and that further development be expanded to include the entire supervisory complex area. The study should include evaluation of such things as wall space and supplementary furnishings, in addition to the basic desk, for three classes of TRACON's, which would serve as a national standard for new TRACON installations and refurbishment of existing TRACON's.

#### MODULAR SUPERVISOR DESK CONCEPT DEVELOPMENT

At the start of the project, the initial approach was to develop a standard desk design for each facility level. This approach was changed during the evaluation of the Philadelphia TRACON supervisor desk when notice of the necessity of constructing the desk in modular form for ease of shipping and installation. Observing the modules which had been constructed for the Philadelphia desk, a representative of Airway Facilities Service noted that these modules could have been used to construct any of the previously built desks. It was decided to redesign the Philadelphia supervisor desk modules into proposed standard modules enabling several supervisor desk designs for the various TRACON's. The initial designs are presented in appendix B. The final designs are depicted in appendix C.

This redesign entailed certain changes to the basic Philadelphia modules (figures 1 to 7). Figure 1 shows rough sketches of the seven modules. Figures 2 and 3 illustrate how the long, main console was divided into two small consoles. This was necessary so that each small console would be available for one-man operation. For two-man operation, two small consoles would be joined together. A 90° corner console (figure 4) was formed as a separate unit, whereas for Philadelphia, it was part of the main console module. The typewriter section was divided into two modules (figure 5) for left-right interchangeability. The typewriter section was also redesigned to allow space for wire runs at the back. The 45° corner console (figure 6) was also made interchangeable. The storage console and bookcase module (figure 7) remained the same in all aspects but one. The Philadelphia storage console had six same-size drawers, the new design incorporated one file-size drawer at the bottom of each drawer pedestal. The main console and pedestal were provided with screened ventilation holes at the backside, top, and bottom, beneath the writing surface, to allow convection cooling of equipment in the turret.

One new module did not exist as a part of the Philadelphia desk. This was the main pedestal module (figure 4), which was designed to be located to the left or right of the main console. The storage console and bookcase are shown in figure 7. Figure 8 depicts a front view of the attached modules forming the maximum size desk.

The last design change incorporated a bookcase behind the main module (figure 9), as well as a nonremovable section of the turret as a location for dimmer switches. The bookcase was tilted back slightly so the backs of the books (spines) could be adequately lit by a light directly above the books. Since this console was different than the main console, it was given the name "prime main console." It was envisioned that this console would be used more than the other main console (i.e., when only one of the two were needed) because of the special features. Figure 10 depicts the outlets and wire runs beneath the removable turret faces.

These units were first mocked-up in foamcore over a plywood frame to demonstrate the feasibility of the initial design. Since the Philadelphia desk already existed in much the same form, the main reason for the mockup was to test the rearrangement and interchangeability of the consoles. Operational capability of the "J" design had already been accepted by field personnel. The operational ability of the "L" and straight-line concepts which could be formed using these modules needed to be evaluated. A subjective evaluation by air traffic controllers was conducted. All found the design concepts operationally feasible.

Various latching mechanisms were discussed. It was decided that the modules would best be constructed with no latching mechanism initially, then joined by field personnel through their own means onsite. Once the modules were placed in position, holes would be drilled and bolts secured insuring optimum lineup onsite. Seams created on the writing surface by joining two units would be overlaid with Plexiglas cut to size. Holes for wire runs could also be drilled either onsite or in construction.

After the feasibility of interconnecting the modules in various ways was demonstrated, construction drawings were completed and forwarded to Airway Facilities Service as recommended designs for standard supervisor desks for all level facilities. (See appendix B). These configurations could take various shapes to suit facility size and layout.

There are many existing TRACON rooms of odd shapes and sizes which were constructed prior to standardization. However, ongoing construction of ATC facilities involve five present standard TRACON configurations according to base building size: 5,000, 8,000, 11,000, 14,500, and 20,000 sq. ft. These are depicted in figures 11 to 15. To accommodate these standard facilities, the supervisor desk modules can be configured in many ways. (See figures 16 to 19.) The modular supervisor desk concept would adapt to both the nonstandard and standard TRACON needs. Figure 20 shows how one room area can accommodate many differently shaped desks.

An item of note which was considered in relation to room layout was the utilization of wall space for the supervisor area. From the field installations and seminar report, it was observed that a properly organized supervisor area involved the judicious use of wall space for many things: through-the-wall equipment, sign-in sheets, clip boards, bookcases, monitor switches, panels, and notices. No recommendation was made as to the placement of these items in this report. However, it was felt that the modular aspect of the supervisor desk allowed variable designs that maximized wall space use.

#### OVERALL ASPECTS OF MODULAR DESK.

The same anthropomorphic and practical criteria were applied to the supervisor desk modules as to the other field support desks.

OVERALL SIZE. The most controversial aspect of overall size was height. Most field support desks in the project were built with an overall height of 42 to 43 inches. Project personnel judged this restriction to be too constricting as it limited turret space available for equipment placement. The height decided upon for the desk modules was 44 inches. This gave greater turret space and was still 3 inches below maximum, as specified by MIL Spec MIL-STD-1472B for adequate "look-over-ability" while seated.

The width of the various modules was governed by various considerations. The 36-inch width of the main console allowed for a standard drawer size plus room beside the drawer for two jacks. The width of the corner console, 30 inches, was dictated by the depth of the main console to which it was attached. The typewriter console width was changed from 40 to 36 inches because when built in combination with the typewriter pedestal at 12 inches, it equaled the 48-inch dimension of stock plywood, while still providing plenty of room for the typewriter carriage return. The width of the 45° console was dictated by the 25-inch front dimension, which was the average width of a chair with arms. The storage console width was a holdover from the Philadelphia desk, but allowed sufficient size for two-drawer pedestals and center bulk storage. The bookcase width of 36 inches allowed placement atop the main console, 45° console, and storage console. This bookcase would be placed against a wall so that it would not interfere with visibility.

WRITING SURFACE. The writing surface for the main module was 36 inches wide, 30 inches high, and 16 inches deep, which conformed to MIL-STD-1472B. The typewriter and 45° consoles were 26 inches high, which conformed to MIL-STD-1472B for keyboard use.

TURRET ACCESSIBILITY. The turret was 16 inches from the front of the main console and thus was as close as possible while maintaining minimum writing surface depth according to MIL-STD-1472B. Turret height was expanded 2 inches from formerly constructed project desks to allow 20 percent more space for equipment placement.

DESK DRAWER SPACE. Modularity would allow final desk design to incorporate as many drawer pedestals as necessary for workload.

STORAGE AND BOOKCASE SPACE. The storage console should provide more than adequate cubic footage for all foreseen storage necessities in the TRACON area. If space prohibits utilization of the storage console, bookcases can be used vertically atop the consoles for storage when the desk is against a wall.

KNEE AND FOOT ROOM. The space under the desk for knee and foot room was 25 inches high by 16 inches deep. MIL-STD-1472B required a space 25 inches high and a minimum of 18 inches deep, but past experience in the project showed no complaints with 16-inch depth. This also allowed for a wider base which gives better stability for the desk.

COLOR. All desks in the project were constructed of gunstock walnut formica on plywood. Rosewood is also popular in TRACON's and towers.

DESK WORKSPACE LIGHTING. The turret task lighting for the modules was taken from the Philadelphia desk. Former complaints indicated that there was a need for more light to be thrown forward on the desk writing surface. To accomplish this, the turret overhang was extended 3 inches longer than former desks, and the light baffle was slanted forward 30°. Evaluation of the Philadelphia desk showed no complaints with this lighting arrangement.

BOOKCASE LIGHTING. There was no foreseen problem with the main console bookcase lighting, since the books were tilted back to expose the binding side (spine) to the light for easy recognition. The free-standing bookcase was not lighted, however a baffle was added in case lights were needed.

PLEXIGLAS COVER EFFECTIVENESS. A Plexiglas cover over the writing surface has been shown to be useful for placing often-used fact sheets underneath for quick visual access. Plexiglas also accomplishes the added task of covering the seams between joined consoles.

MAINTENANCE ACCESSIBILITY OF EQUIPMENT. Removable panels behind the turret allowed for complete accessibility to inserted turret equipment. The turret itself was removable to aid in this.

CONSTRUCTION DETAILS OF THE MODULAR DESK.

The following details were considered in construction of the supervisor desk modules.

1. Supervisory console modules should be built according to the Architectural Woodwork Institute (AWI) "Premium Quality Standards."
2. The construction material should be fir plywood, not particle board.
3. The finish material should be laminated plastic such as formica gunstock walnut No. 492; 64 finish or equal.
4. Hinges should be Stanley Model No. 1585 (2 1/2-inch) or equal.
5. Flush drawer pulls should be Knappe and Vogt 819 x P13 or equal.
6. Drawer runners should be Knappe and Vogt No. 1300 or equal.
7. All sides of every module should be covered by plastic laminate to facilitate rearrangement of modules which may be required from time to time.
8. All interiors and undersurfaces should be finished in formica backing.

CONCLUSIONS

Based on the experience and feedback gathered from construction of several supervisory desks at various level facilities and from initial review of the developed prototype supervisor desk modules, it is concluded that:

1. The proposed standard modules for utilization at level I through V Air Traffic Control (ATC) Terminal Radar Approach Control (TRACON) facility will accommodate the spacial element and equipment needs of standard and special dimension TRACON rooms at each level.
2. Economics of expenditure and time will be gained through elimination of the preliminary planning phase in design of supervisor desks for various refurbishments or new facilities.
3. Utilization of these modules will allow economy by producing standard desks versus special one-of-a-kind construction of special desks for each refurbished or new facility.

4. Gain in experimental optimization will be accomplished since the modular approach incorporates multiple user design suggestions over the years.

5. Flexibility of configuration is gained using modules rather than fixed "U," "L," "J," or "I" shaped desks. Facilities are free to utilize the modules which best accommodate their own space and needs.

#### RECOMMENDATION

Based upon the results described in this report, the recommendation is made that the modular supervisor desk units developed under this project be used as the national standard for new Terminal Radar Approach Control (TRACON) installations and refurbished TRACON's.

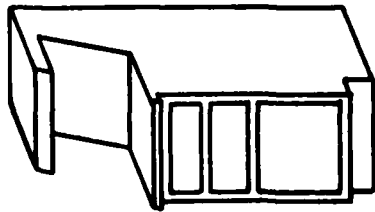

**B**  
MAIN PEDESTAL

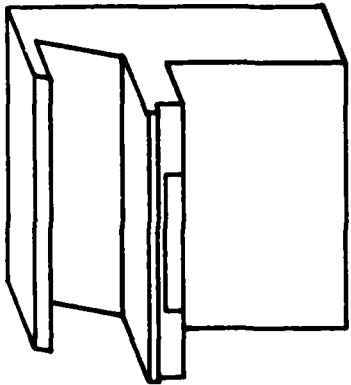

**A**  
MAIN CONSOLE

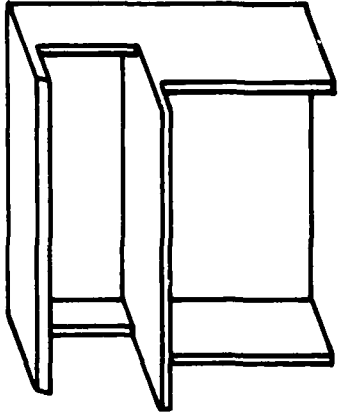

**D**  
TYPEWRITER CONSOLE

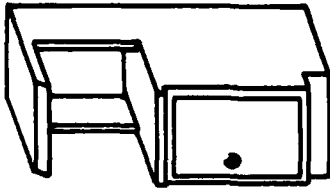

**E**  
TYPEWRITER PEDESTAL

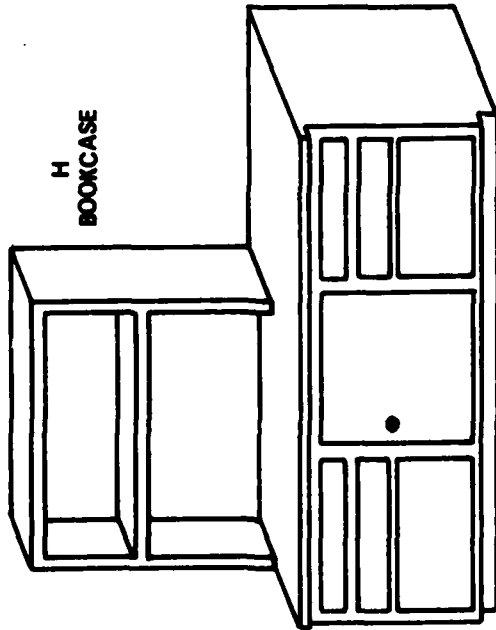

**G**  
STORAGE CONSOLE

**H**  
BOOKCASE

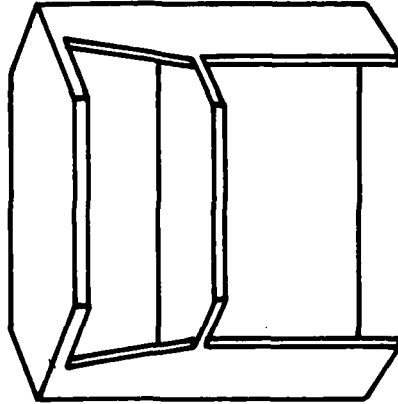

**F**  
45° CORNER CONSOLE

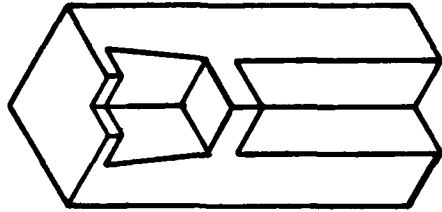

**C**  
90° CORNER CONSOLE

FIGURE 1. SUPERVISOR DESK MODULES

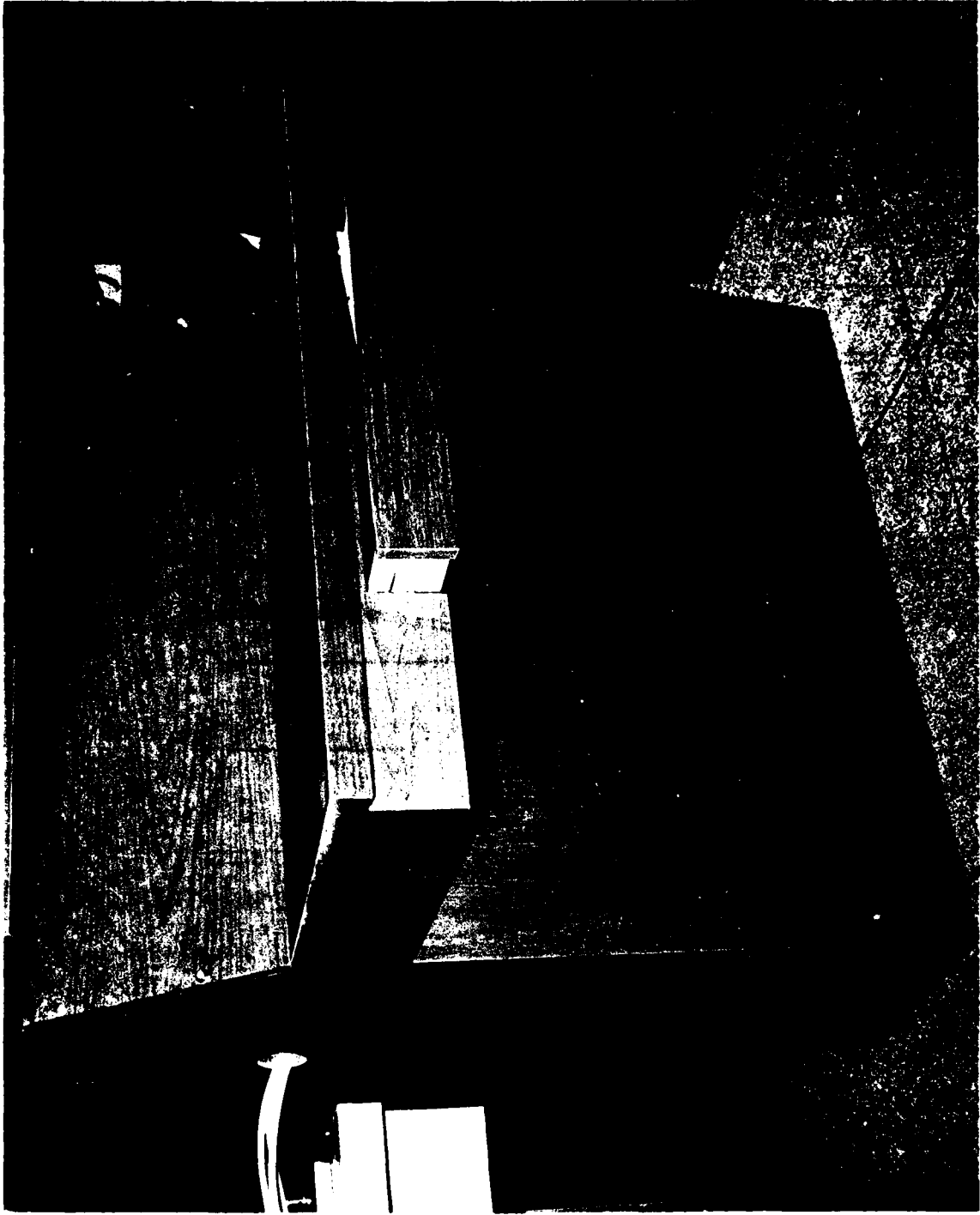

FIGURE 2. MAIN CONSOLE (A)

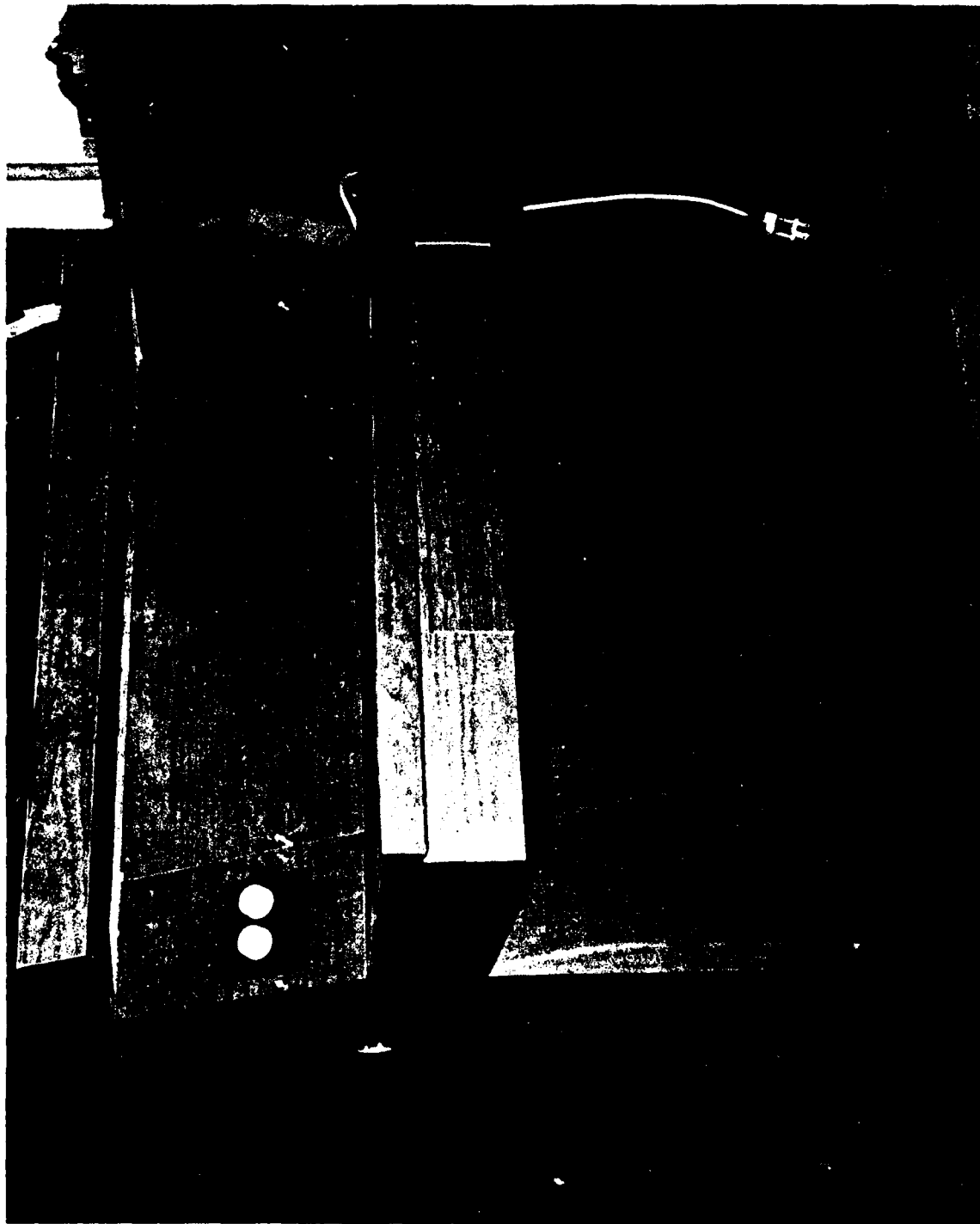

FIGURE 3. MAIN CONSOLE WITH BOOKCASE AND DIMMER (A)

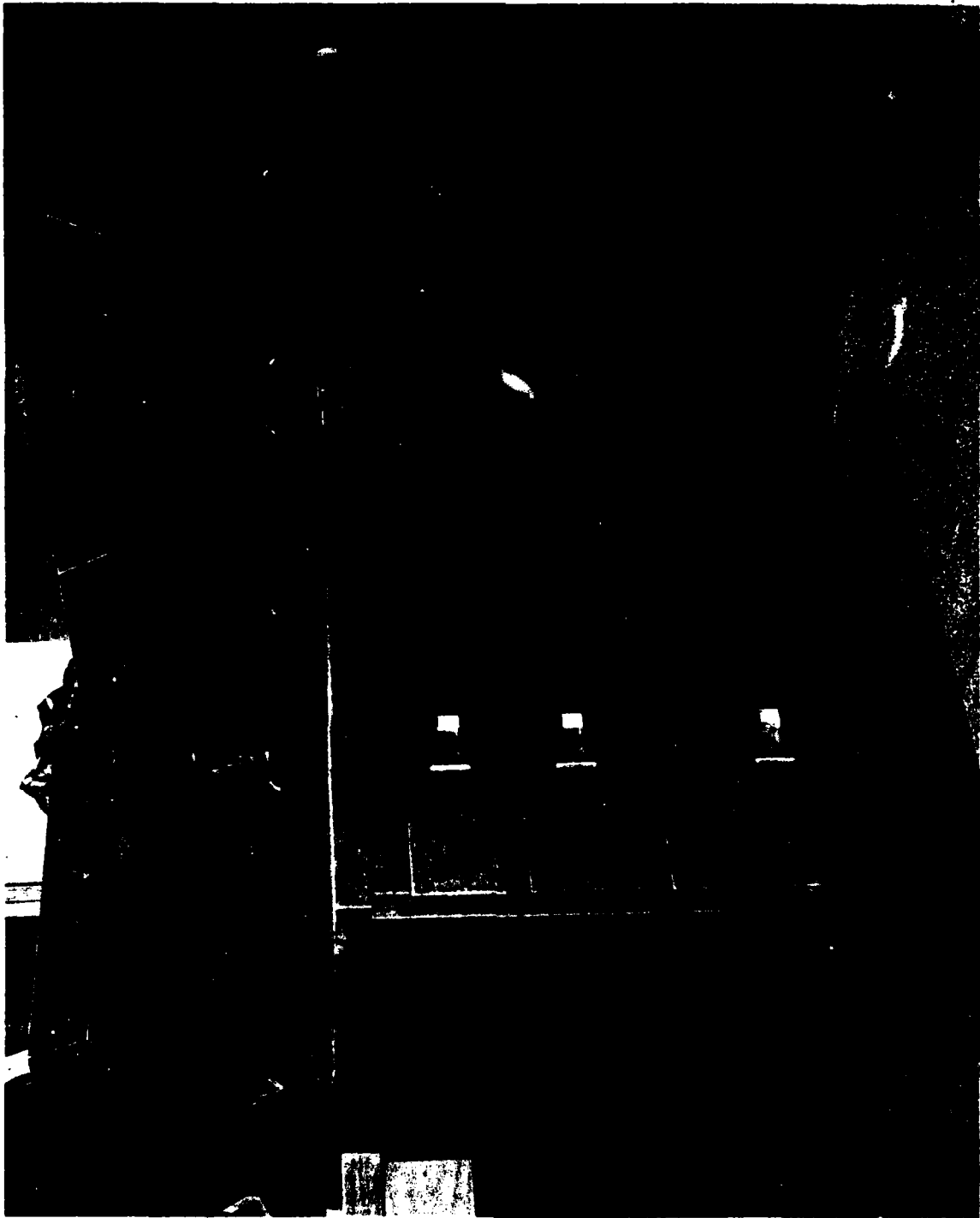

FIGURE 4. MAIN PEDESTAL (B) AND 90° CORNER CONSOLE (C)

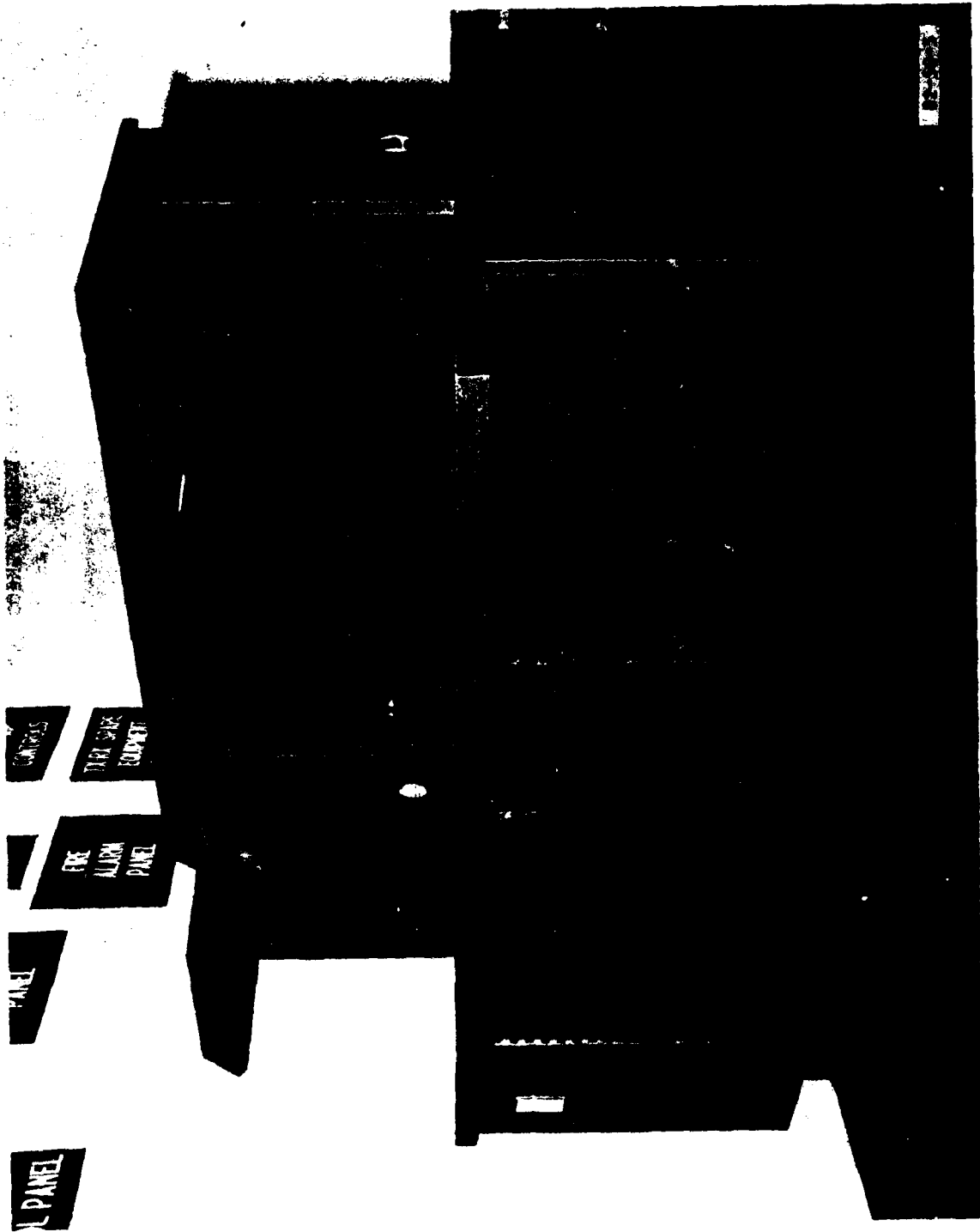

FIGURE 5. TYPEWRITER CONSOLE (D), AND TYPEWRITER PEDESTAL (E)



FIGURE 6. 45° CORNER CONSOLE (F)

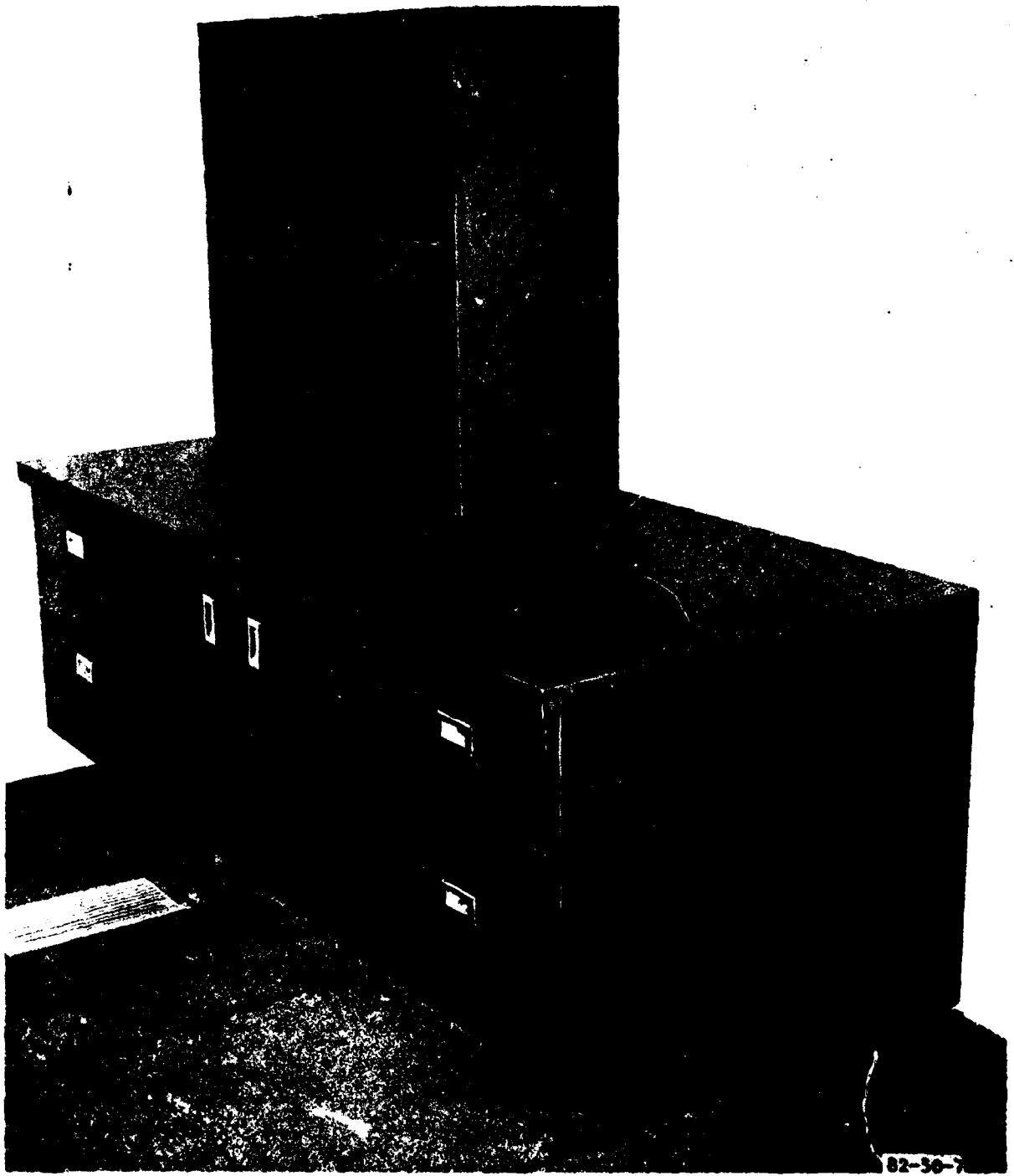

FIGURE 7. STORAGE CONSOLE (G) AND BOOKCASE (H)

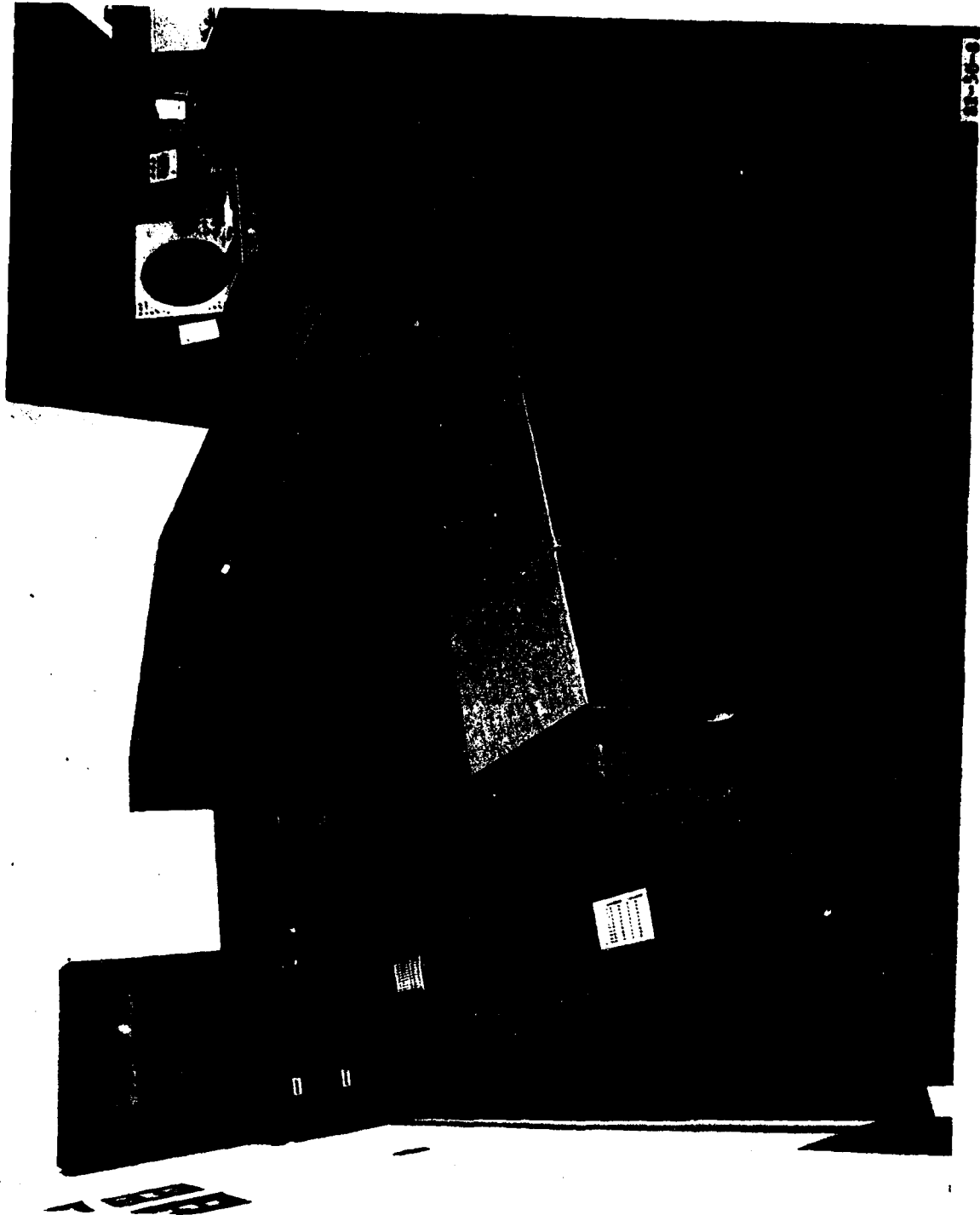

FIGURE 8. FRONT VIEW OF ATTACHED MODULES

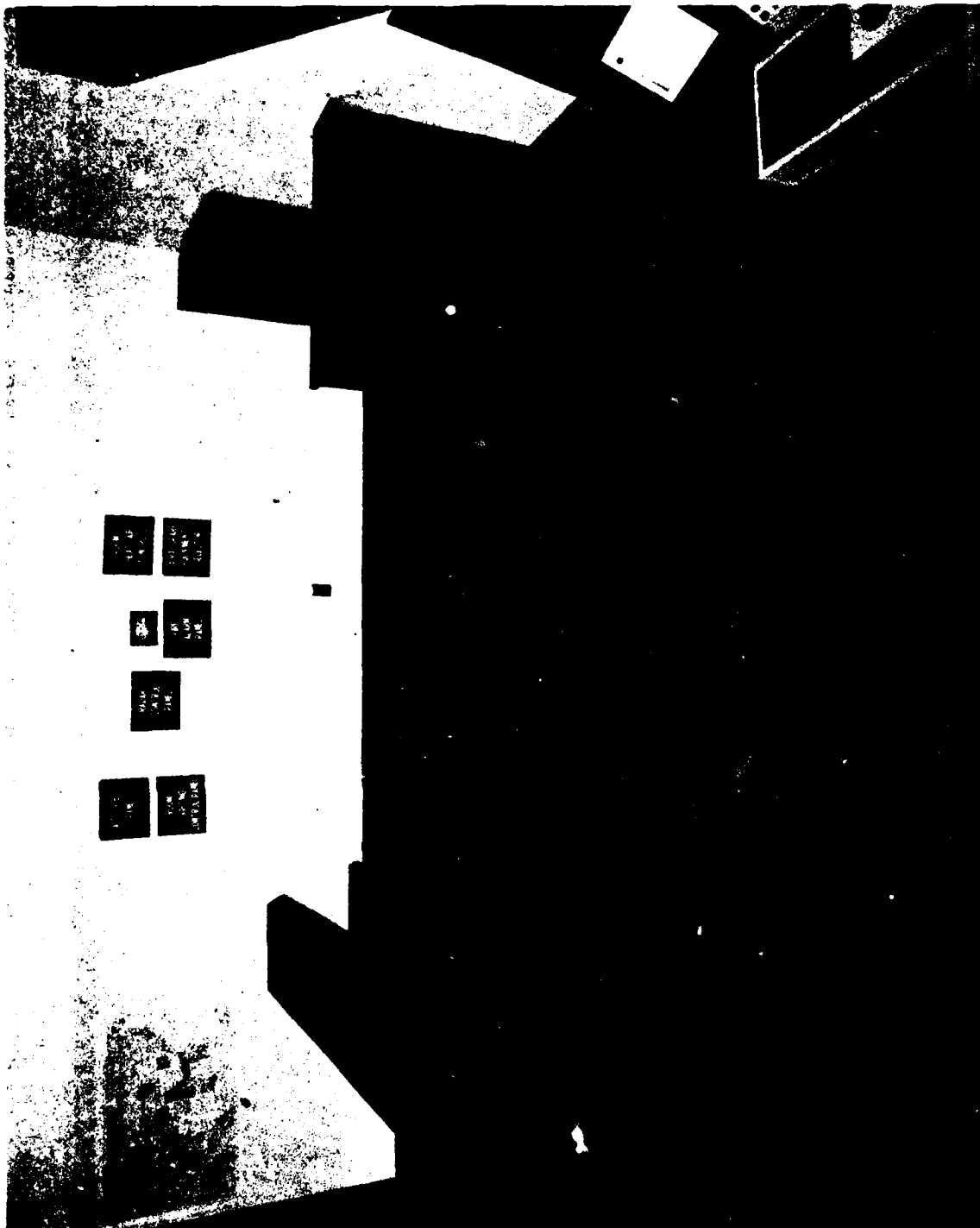
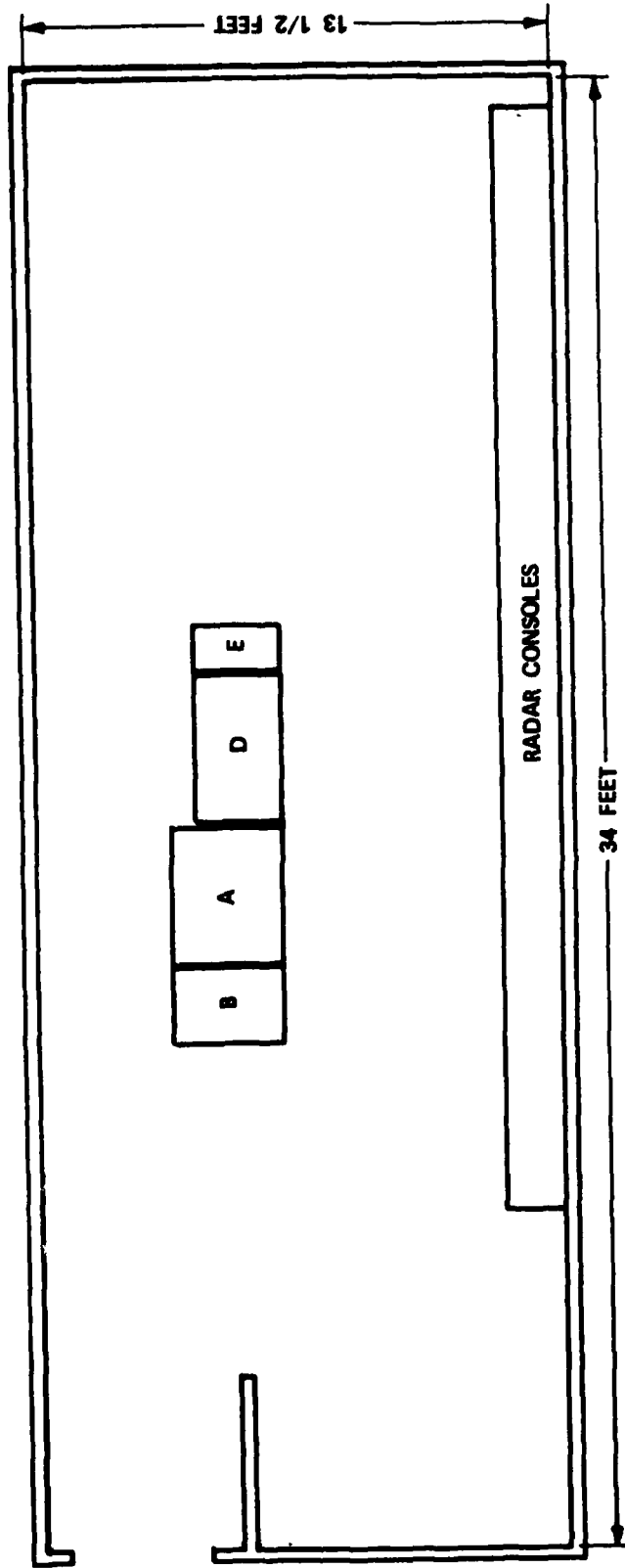

FIGURE 9. BACK VIEW OF ATTACHED MODULES



FIGURE 10. VIEW OF WIRE RUNS AND OUTLETS BEHIND TURRET



NOT TO SCALE

82-50-11

FIGURE 11. SUPERVISOR DESK AREA FOR 5,000 SQ. FT. TRACON BUILDING

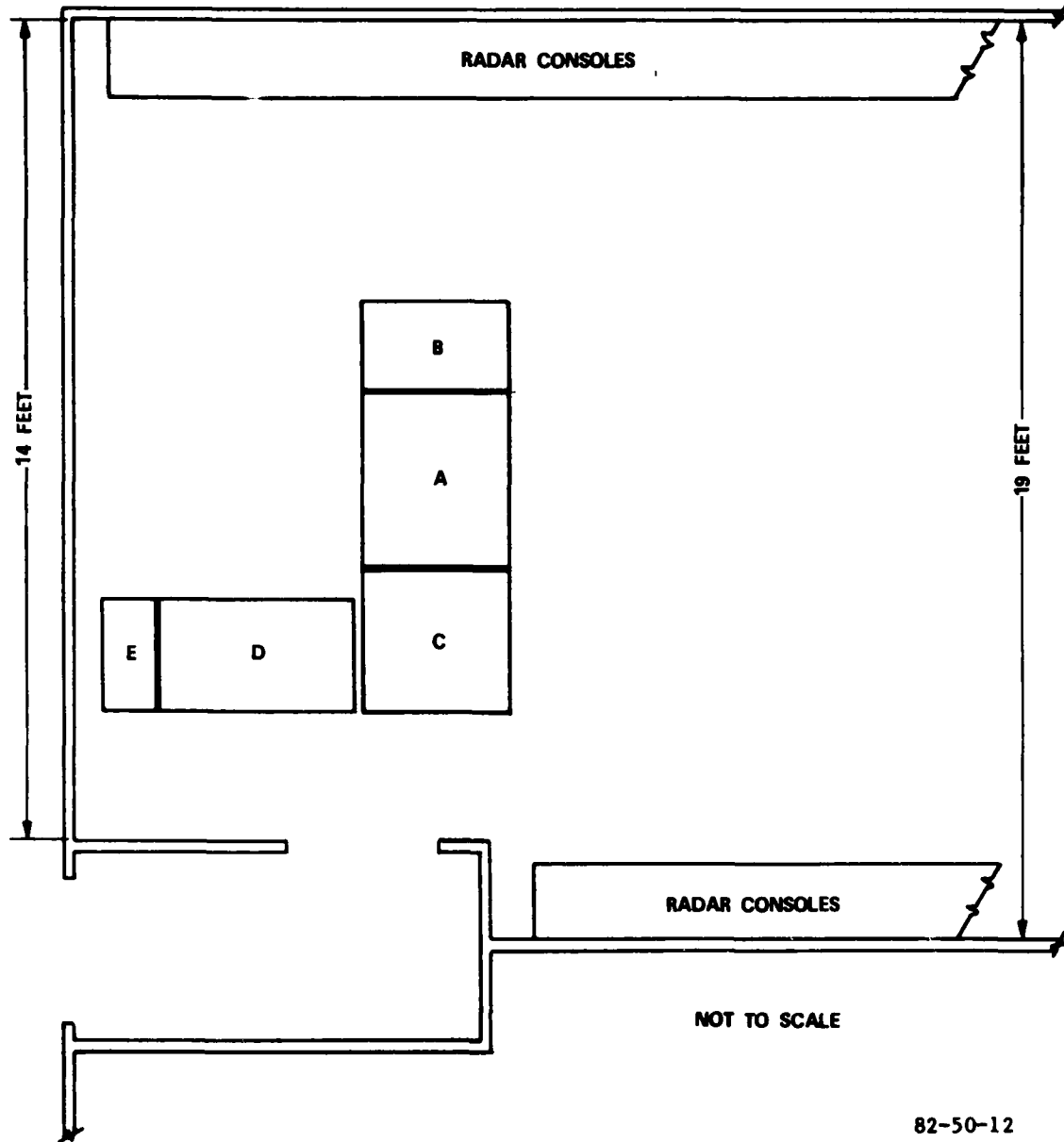
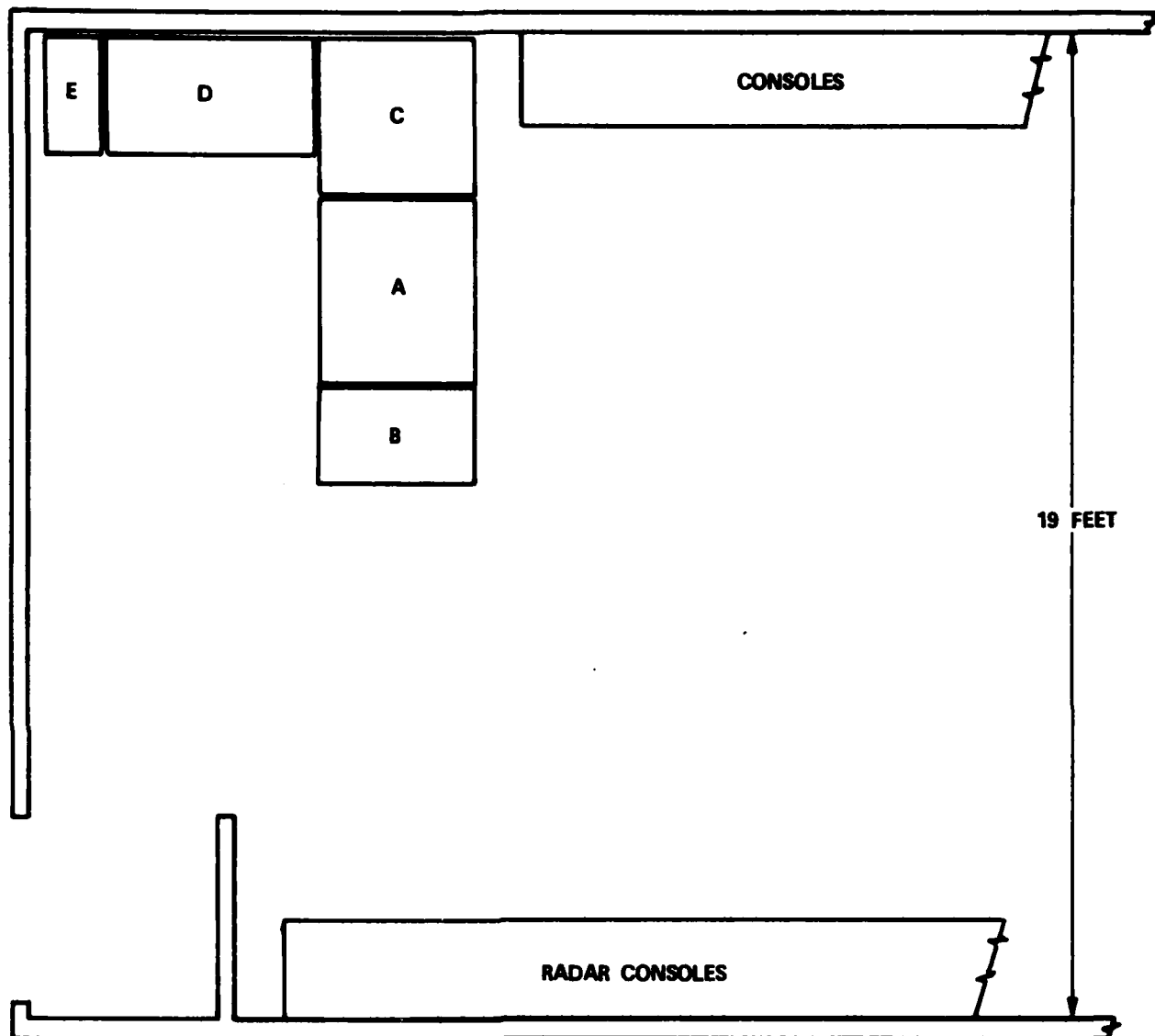

FIGURE 12. SUPERVISOR DESK AREA FOR 8,000 SQ. FT. TRACON BUILDING



NOT TO SCALE

82-50-13

FIGURE 13. SUPERVISOR DESK AREA FOR 11,000 SQ. FT. TRACON BUILDING

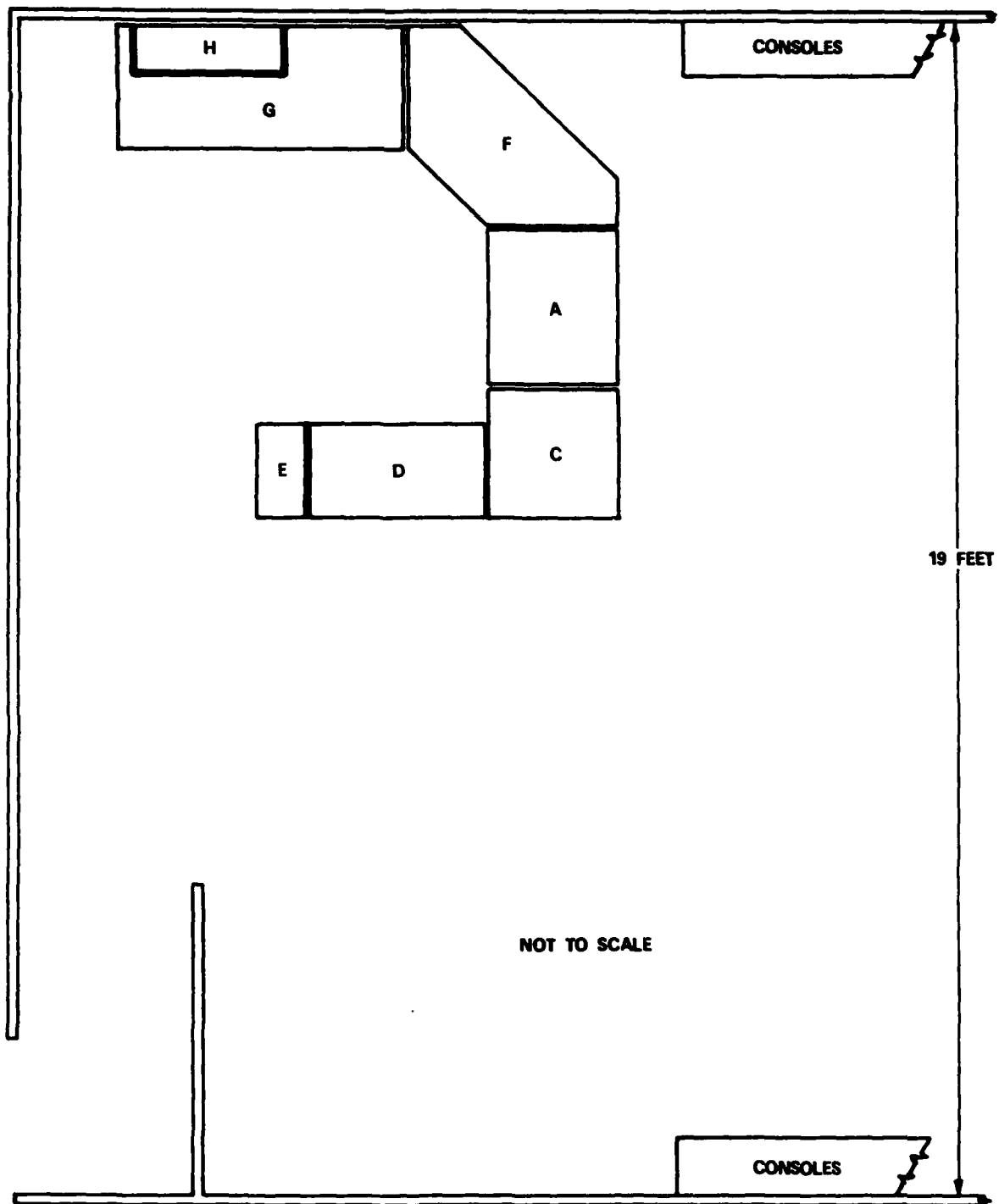

82-50-14

FIGURE 14. SUPERVISOR DESK AREA FOR 14,500 SQ. FT. TRACON BUILDING

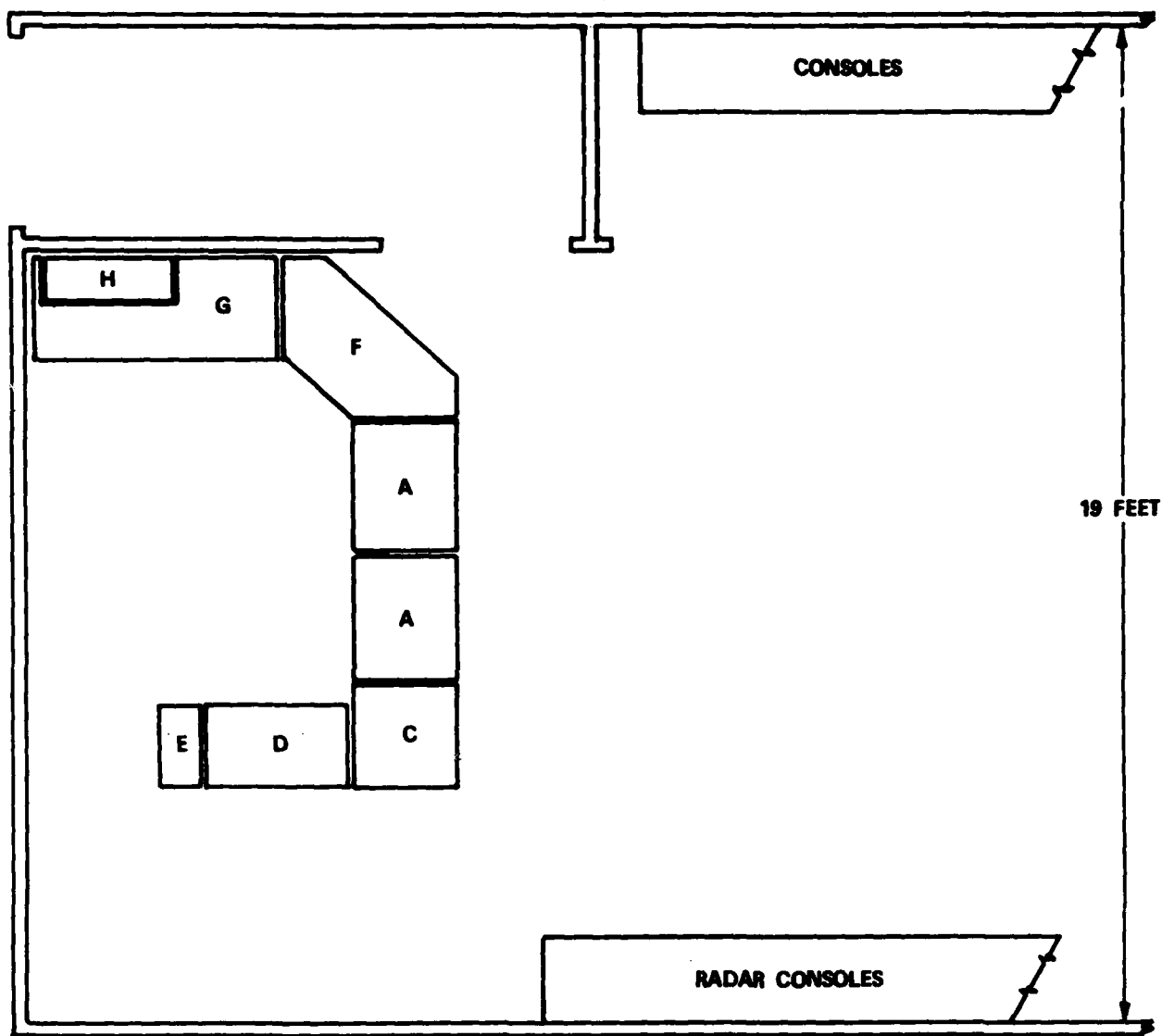

NOT TO SCALE

82-50-15

FIGURE 15. SUPERVISOR DESK AREA FOR 20,000 SQ.FT. TRACON BUILDING

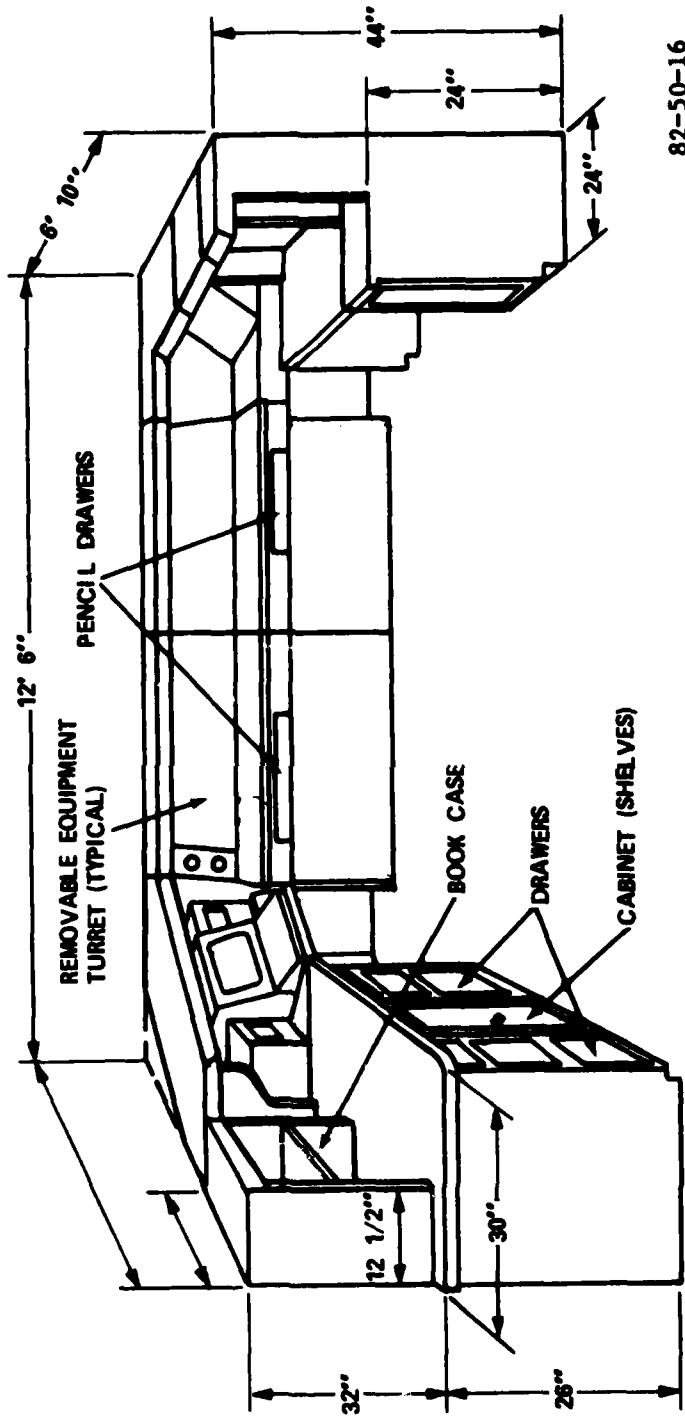

82-50-16

FIGURE 16. SUPERVISOR DESK 'J' CONFIGURATION

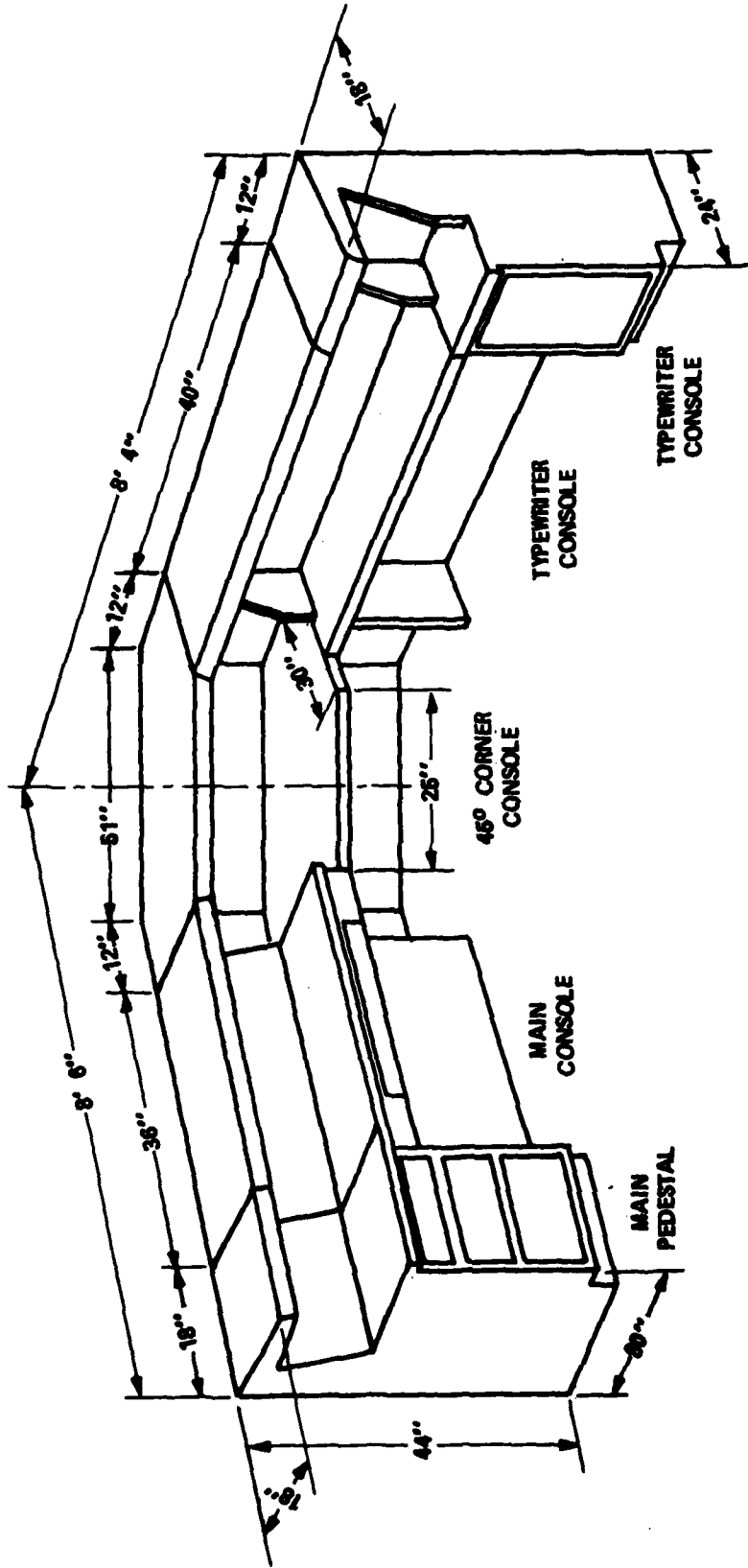

82-50-17

FIGURE 17. SUPERVISOR DESK "BIG L" CONFIGURATION

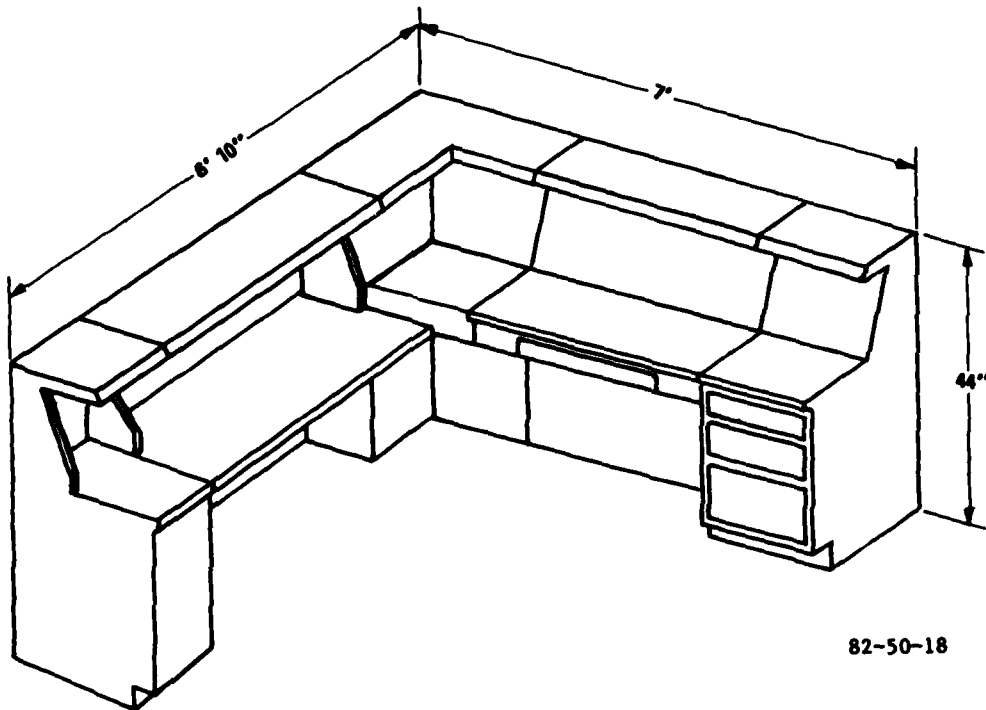

82-50-18

FIGURE 18. SUPERVISOR DESK "LITTLE L" CONFIGURATION

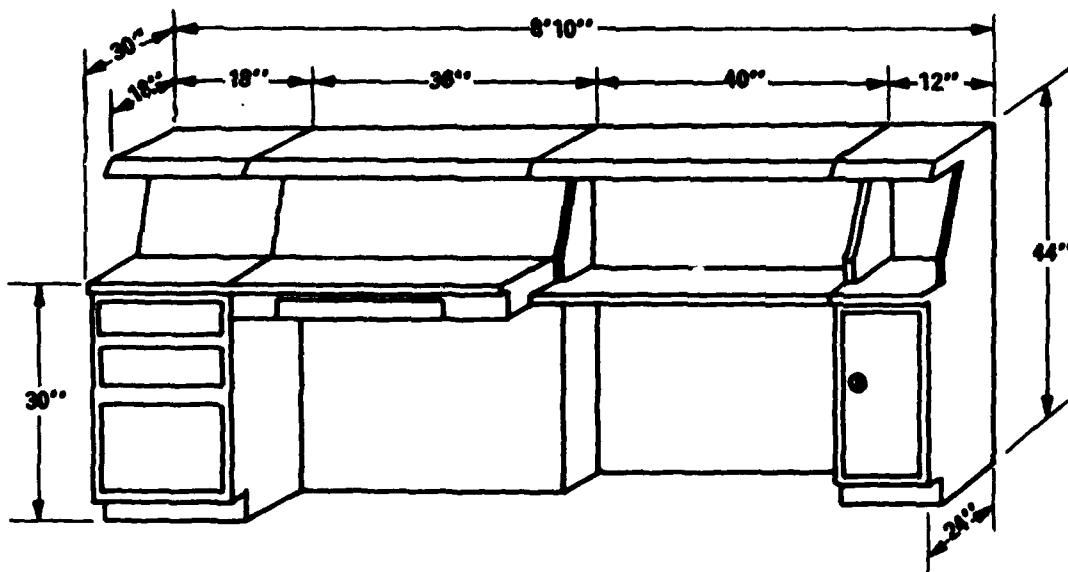

82-50-19

FIGURE 19. SUPERVISOR DESK IN-LINE CONFIGURATION

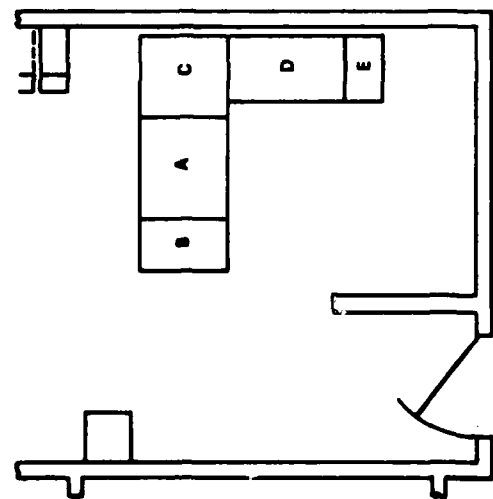
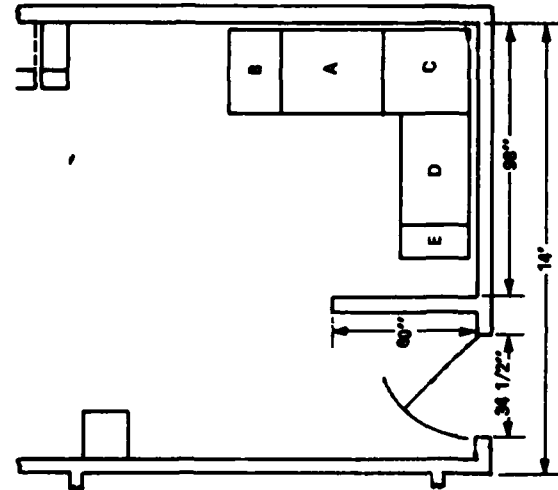
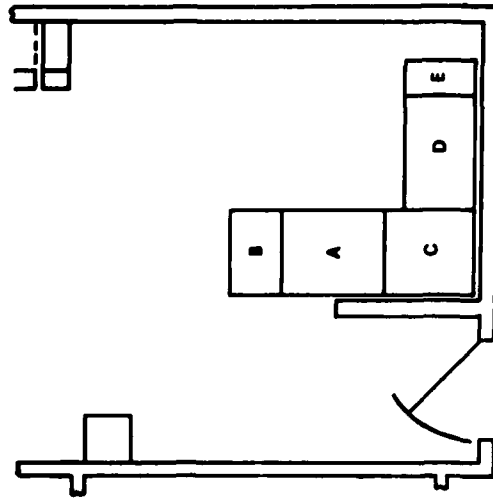
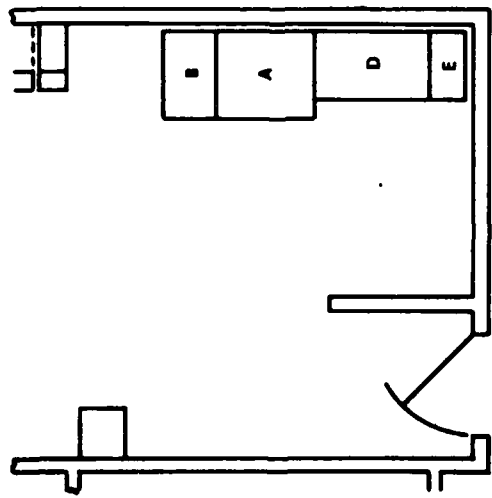
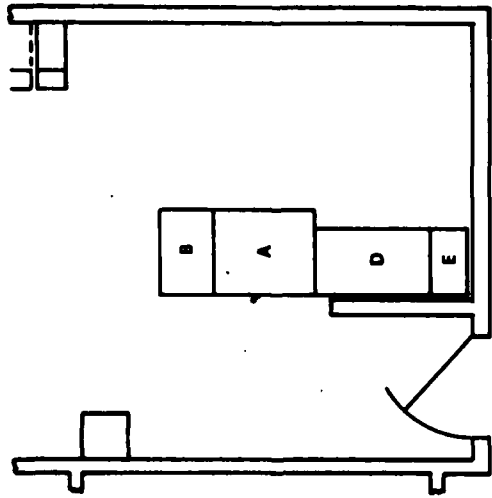

82-50-20

NOTE: ALL MEASUREMENTS ARE TYPICAL

FIGURE 20. VARIOUS CONFIGURATIONS FOR SAME ROOM SIZE

APPENDIX A

FIELD-IMPLEMENTED SUPERVISOR DESK DESIGNS

LIST OF ILLUSTRATIONS

Figure		Page
A-1	Atlantic City TRACON Supervisor Desk, Pictorial	A-6
A-2	Atlantic City TRACON Supervisor Desk, Front View	A-7
A-3	Atlantic City TRACON Supervisor Desk, Back View	A-8
A-4	Atlantic City TRACON, Plan View	A-9
A-5	Tallahassee Supervisor Desk	A-10
A-6	Denver Supervisor Desk	A-11
A-7	Denver Supervisor Desk Layout	A-12
A-8	Windsor Locks Supervisor Desk	A-13
A-9	Futurama Supervisor Desk Concept	A-14
A-10	Colorado Springs Supervisor Desk, Front View	A-15
A-11	Colorado Springs Supervisor Desk, Back View	A-16
A-12	Baltimore Supervisor Desk, Left Side	A-17
A-13	Baltimore Supervisor Desk, Right Side	A-18
A-14	Baltimore Supervisor Desk, Back View	A-19
A-15	Dulles Supervisor Desk, Left Side	A-20
A-16	Dulles Supervisor Desk, Right Side	A-21
A-17	Dulles Supervisor Desk, Back View	A-22
A-18	South Bend Supervisor Desk, Front View	A-23
A-19	South Bend Supervisor Desk, Back View	A-24
A-20	Charlotte Supervisor Desk, Front View	A-25
A-21	Charlotte Supervisor Desk, Back View	A-26
A-22	Burbank Supervisor Desk, Main Console	A-27

LIST OF ILLUSTRATIONS (Continued)

Figure		Page
A-23	Burbank Supervisor Desk, Main Pedestal	A-28
A-24	Burbank Supervisor Desk, Corner Console	A-29
A-25	Burbank Supervisor Desk, Typewriter Console	A-30
A-26	Burbank Supervisor Desk Assembled	A-31
A-27	Philadelphia Supervisor Desk, Left View	A-32
A-28	Philadelphia Supervisor Desk, Right View	A-33
A-29	Philadelphia Supervisor Desk, Back View	A-34

## APPENDIX A

### INTRODUCTION.

This appendix contains descriptions of twelve supervisor desks which were designed for the Terminal Radar Approach Control (TRACON) facilities evaluated in this project. These were the designs which evolved into the final modular concept.

### DESCRIPTION OF DESKS.

#### ATLANTIC CITY SUPERVISOR DESK.

This desk was constructed at the FAA Technical Center and shipped to the Atlantic City TRACON (ACY). It was the first phase of the project and was not designed as a standard, but only to solve a unique problem for the ACY facility. The desk design allowed the Flight Data Entry and Printout (FDEP) printer and flight strip bays to be collocated at the supervisor desk for ease of access for both supervisor and controller personnel (figures A-1 through A-4). Additional equipment was also centrally located at this desk, such as a typewriter stand, strip holders, reference bookcases, and instrumentation. The desk design made these items more readily accessible to both controller and supervisory personnel. The result was less cluttered and better organized workspace through desk design.

#### TALLAHASSEE SUPERVISOR DESK.

The desk (figure A-5) for the Tallahassee Municipal Airport TRACON, Tallahassee, Florida, was adapted from a standard L-shaped secretary's desk. A two-door filing cabinet pedestal was added to the end of the desk. A new writing surface and a raised portion or turret were added on the same side. The wall space on the other side (typewriter side) of the desk was functionally integrated for utilization with lighting and bookcases. This was the only metal desk in the project that was so adapted. Modifications were accomplished at the Technical Center and shipped to the site for installation.

Some less favorable aspects can be seen from the illustration of the desk. For instance, the turret area was not utilized fully for telephone inserts; the collocation of filing cabinets to one side gave limited access. A better design would locate the two-drawer pedestals on either end of the desk. Further evaluation determined that the light fixture located on the typewriter side of the desk was not necessary.

#### DENVER SUPERVISOR DESK.

The TRACON supervisor desk at Stapleton International Airport, Denver, Colorado, was the first attempt to construct a standard L-shaped desk made of wood and formica (figures A-6 and A-7). It incorporated a special typewriter area, recessed below writing surface height, and a full wraparound turret canopy for lighting. These concepts were similar to the Tallahassee desk. Also similar was the later addition of a drawer pedestal at the end of the desk for files and storage. The desk was constructed at the Technical Center, shipped in sections, and assembled onsite.

During its evaluation, some shortcomings were uncovered in the Denver supervisor desk design. First, the typewriter area was cramped, and the typewriter carriage return did not have full swing because of inadequate space. However, a typewriter with a stationary carriage could be adequately accommodated in this space. Placement of light dimmer switches on the desk near the arm of the chair was a disadvantage. Subsequent experience has shown that the arm of the chair has played havoc with these switches. A lighting problem, whereby the desk writing surface was inadequately lighted, was less obvious. The addition of a gooseneck lamp was utilized to correct this problem.

Structural deficiencies were also encountered. The drawer rails were not stopped at the rear. Stopping only at the front resulted in the front face of the drawer being separated from the drawer sides due to slamming. The bookcase area located on the desk was utilized for storage, but was not accessible for immediately needed or frequently used reference material. These materials were placed on top of the turret for easy availability.

#### WINDSOR LOCKS SUPERVISOR DESK.

The Windsor Locks TRACON supervisor desk at Bradley International Airport, Windsor Locks, Connecticut, was a second attempt at a standard design. This time the desk (figure A-8) took a U-shaped design and incorporated several features that were different than the Denver desk.

Of primary concern was the accessibility of equipment to the supervisor. Bookcases and drawers were immediately to the right and left, below desktop and turret. A Conrac cathode ray tube (CRT) monitor was added to the right-hand side and was sunk into the turret. The typewriter tray and hood pulled out for operation. The writing surface was lighted by recessed turret-top lighting. A bookcase for the storage of manuals was located on the back, left side with a light and dimmer.

Evaluation of this design revealed that it had some shortcomings. The main problem was that the work area was too cramped. Drawers pulling out from the left and right imposed into the chair area. The Conrac CRT would have required additional cooling for proper operation and could not be installed. The writing surface area was minimal, and the placement of the light dimmer switches allowed contact with the arms of the chair. This desk was constructed at the Technical Center, disassembled, and shipped in sections to the facility.

#### FUTURAMA SUPERVISOR DESK.

At this point, an attempt was made to incorporate all of the favorable features developed for previous desk designs into a supervisor desk which could accommodate all envisioned futuristic equipment for the largest of TRACON's. It was realized that this desk could be relevant only to the largest, most current configured TRACON. This desk was built of wood and formica at the Technical Center as depicted in figure A-9. It accommodated two positions.

The following refinements were incorporated in this design: The typewriter area was expanded for increased leg and carriage room. An electronic display, plus keyboard, was added on the left side at typewriter height for projected use of automated information. Dimmer switches were removed from armchair height and were optimally placed. Bookcases and storage cabinets were provided on the right side of the desk. There was room provided for a Conrac CRT on the left side.

Evaluation of this desk by sponsor personnel indicated that it was too big. However, the desk design did serve as a model for later designs of approximately the same size. It was later cut into two sections and used for L-shaped supervisor desks at two facilities.

#### COLORADO SPRINGS SUPERVISOR DESK.

This desk (figures A-10 and A-11) was designed for the Peterson Air Force Base, Colorado Springs, Colorado, incorporating aspects from both Denver and Windsor Locks supervisor desks. It had two turret areas: one for recessed equipment and the other, on the typewriter side which was open in the front and lighted within, to accommodate a typewriter.

This desk went far to coordinate the supervisor's equipment, but some of the previous problems noted in earlier desk designs still remained. The dimmer switches interacted as obstacles with the arms of the chair, and the typewriter area was too small. The reason that these problems had not been corrected by this time was the delay in evaluation feedback from the other designs. This desk was constructed at the Technical Center, shipped disassembled, and installed at the site.

#### BALTIMORE SUPERVISOR DESK.

In order to accommodate a request for a supervisor desk for the TRACON at the Baltimore-Washington International Airport, Baltimore, Maryland, it was decided, because of time constraints, to divide the Futurama desk into two pieces and use one of the two for Baltimore (figures A-12, A-13, and A-14). The modification was accomplished by Technical Center personnel, and the desk was shipped disassembled to the site. Referring to the illustration of the Futurama desk (figure A-9), the section that was utilized was the L-shaped, right-side section that included the typewriter.

After installation, a section was added to the L-shaped desk to form a U-shaped configuration. This added section was configured for equipment turret-mounted, and used for book and form storage. Since this section was against the wall, there was no restriction to visibility caused by items atop the turret. Overhead framing lights were used to augment turret lights.

Since this desk was not custom designed as a modular unit or as a proposed standard for this level facility, some problems were evident, from the design standpoint, in its utility. The main flaw was the placement of drawer pedestals. The supervisor, in swinging around in the chair to use the typewriter or equipment, could catch his knee on the leading edges of the drawer pedestals. Pulling out the drawers from these pedestals also could become an obstacle. The placement of the dimmer switches was not optimal as they could be struck by the chair. The placement of most commonly utilized equipment should be established on the turret directly in front of the supervisor instead of off to the side.

#### DULLES SUPERVISOR DESK.

The left side of the Futurama desk (figure A-9) was the basis for the desk in the TRACON at the Dulles International Airport, Chantilli, Virginia. The modification was made by Technical Center personnel and the desk was installed at the site.

At Dulles, the L-shape of the desk was preserved although an extra pedestal of file cabinet drawers was added (figures A-15, A-16, and A-17). The turret area, as compared to the Baltimore desk, was more fully utilized, incorporating supporting equipment. This design could support a two-man operation.

#### SOUTH BEND SUPERVISOR DESK.

Michiana Regional Airport, South Bend, Indiana, was a level III TRACON facility, and it was felt that a prototype level III supervisor desk should be designed for use there. The design was an L-shaped, mirror image of the desk designed for the Charlotte, North Carolina, level IV TRACON facility (figures A-18 and A-19). The South Bend desk was designed for a one-man operation. Typing and turret space for inserted equipment were provided. The desk was built at the Technical Center, transported in two sections, and assembled onsite.

Problems incurred were few. However, in the opinion of the facility chief the desk was too large. Also, there was still a problem with placement of the dimmer switches which could be impacted by the arms of the chair. (Again, evaluation feedback recommending relocating the switches had not yet been received.)

#### CHARLOTTE SUPERVISOR DESK.

The level IV Douglas Municipal Airport, Charlotte, North Carolina, TRACON had a need for a supervisor desk. An L-shaped desk (figures A-20 and A-21) was designed as a mirror image of the South Bend supervisor desk. It was constructed at the FAA Technical Center and transported in two sections to the site.

This supervisor desk was designed for a one-man operation. Typing and turret space for recessed equipment was provided. Lighting was provided in the form of incandescent bulbs located under the turret hood. Electric wire runs were placed behind the turret, and a tray for wire runs was constructed behind the turret. Outlet boxes were provided inside the turret for equipment plug-in.

Bookcases were provided on the back side of the desk. An incandescent light bulb was inset above the bookcases for illumination, and a dimmer switch was also located above the bookcases. Removable panels at the back side behind the turret allowed access to equipment for maintenance.

#### BURBANK SUPERVISOR DESK.

A request for a new supervisor desk was received from the Western Regional Office, for the commissioning of the new Burbank International Airport TRACON building, Burbank, California. Technical Center personnel visited the facility and obtained a list of equipment and space limitation dimensions for the desk. The desk was constructed of plywood and formica at the Technical Center and shipped to the Burbank facility, where it was installed by Technical Center personnel.

It was realized at the time that certain economies of scheduling must be made in order to meet the commissioning date. A decision was made to incorporate presently existing segments of predesigned supervisor desks already constructed as a base for the design of the requested L-shaped desk.

From the photos, the existing sections that were modified for Burbank were the A and B sections shown in figures A-22 and A-23. The C and D (figures A-24 and A-25) sections were new. Breaking down the desk into modules allowed for ease of transportation and reconfiguration.

This desk incorporated some solutions to previous problems. It was the first to incorporate a sloped-hood segment to shield the lights. This slope allows the light to be cast forward for improved coverage on the writing surface. Dimmer switches were located on the turret to preclude chair impact. A separate storage section contained slotted bins for forms storage which allowed easy access. Figure A-26 shows the full desk.

#### PHILADELPHIA SUPERVISOR DESK.

The necessity for a supervisor desk at the newly constructed TRACON facility at Philadelphia International Airport, Philadelphia, Pennsylvania, presented the opportunity to develop a standard design for a level V facility. Discussion with field personnel indicated that they desired a J-shaped desk which incorporated the best of the features developed for former project desks. The desk was designed and built at the Technical Center and shipped to Philadelphia in four sections and reassembled on site.

The Philadelphia "J" design (figures A-27, A-28, and A-29) was similar to the Futurama "U" concept in overall size and many other features. The main differences included the shortening of the typewriter side which gave it a "J" rather than a "U" shape, but allowed greater access into the supervisor area proper. Also, instead of designing two right-angle corners, the desk had one right-angle corner and one 45° corner that consisted of an equipment console. This 45° equipment corner allowed for the placement of futuristic (planned) terminal input and display devices. It also allowed clearance of wall obstacles on the back side.

Many features of this desk were gleaned from experience. Dimmer switches were located in the turret area. The light shield located on the hood above the turret was slanted forward to allow more light to reach the writing surface, and the hood itself was extended forward 3 inches for the same purpose. The overall height of the desk was expanded to 44 inches rather than 42 inches to allow more turret space at the same time maintaining look-over-ability. The typewriter area was expanded to allow full carriage travel.

A bookcase with inset light was located at the back side of the desk with appropriate light dimmer. However, experience has taught that book storage was also needed close to the position. This bookcase was provided along with light shields atop each shelf for the placement of inset light bulbs.

It was surmised that this desk provided all the desktop area and arrangement necessary for the largest and most advanced level V TRACON space and equipment needs. (Placement of the desk on an 8-inch elevated platform at the Philadelphia facility was not a part of the desk design.)



82-50-A-1

FIGURE A-1. ATLANTIC CITY TRACON SUPERVISOR DESK, PICTORIAL

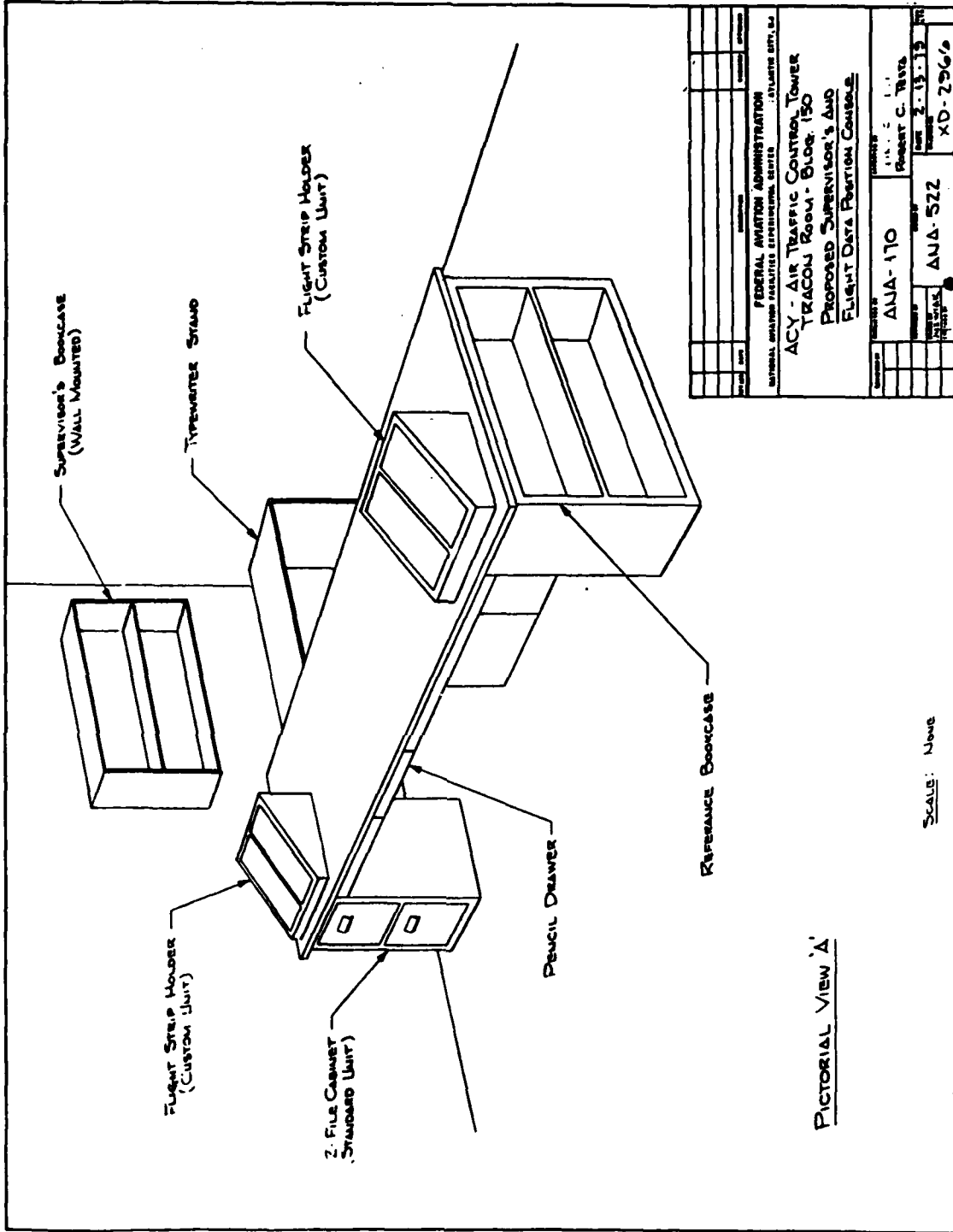

FEDERAL AVIATION ADMINISTRATION		ATLANTA OFFICE, GA	
NATIONAL OPERATIONAL DIRECTORATE OPERATIONAL SERVICES			
ACY - AIR TRAFFIC CONTROL TOWER			
TRACON Room - Block 150			
PROPOSED SUPERVISOR'S DESK			
FLIGHT DATA POSITION CONSOLE			
PROJECT NO.	ANA-170	DATE	2-13-66
DESIGNED BY	Robert C. Travis	SCALE	AS SHOWN
CHECKED BY	ANA-522	PROJECT NO.	XD-2966

SCALE: None

82-50-A-2

FIGURE A-2. ATLANTIC CITY TRACON SUPERVISOR DESK, FRONT VIEW

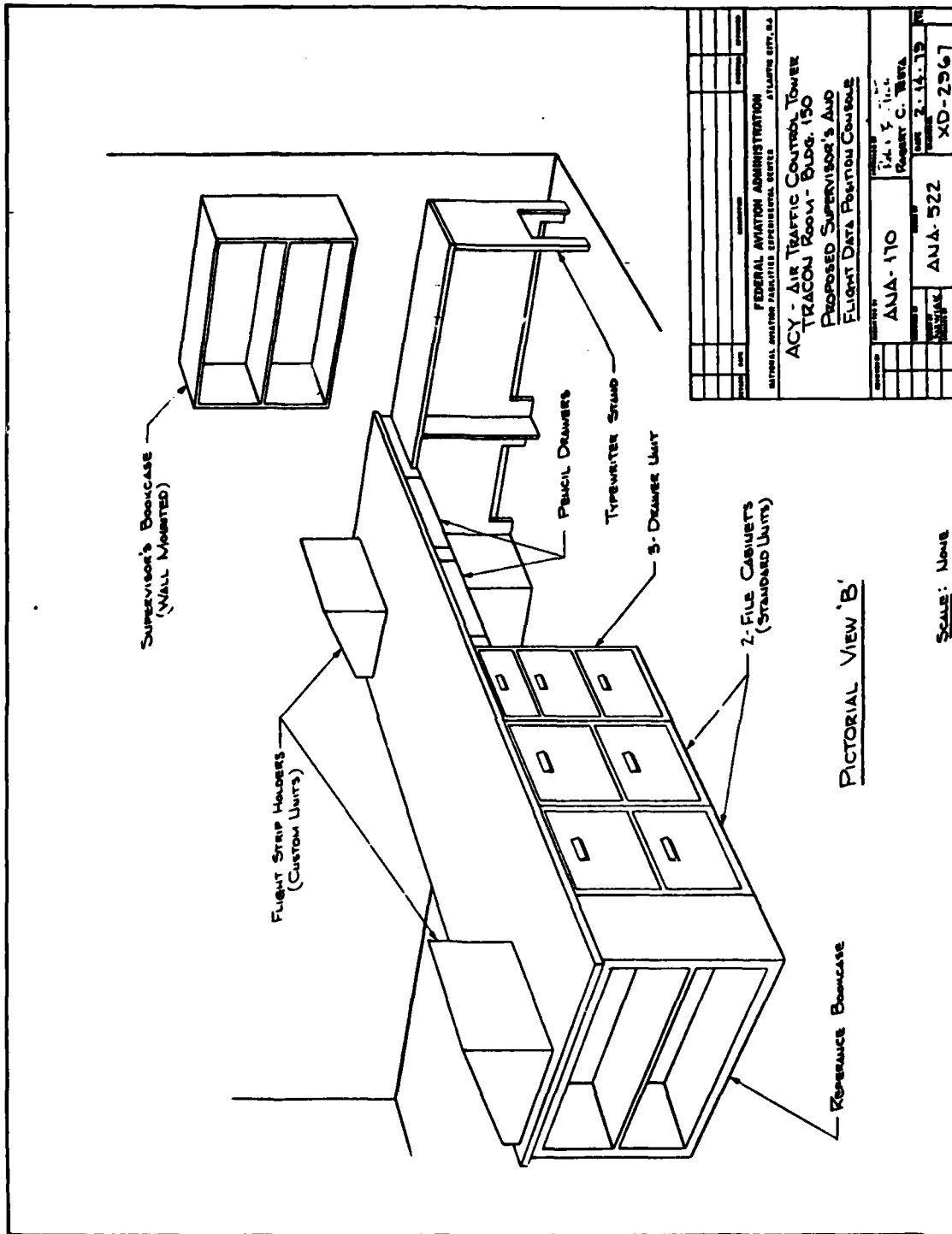

FIGURE A-3. ATLANTIC CITY TRACON SUPERVISOR DESK, BACK VIEW



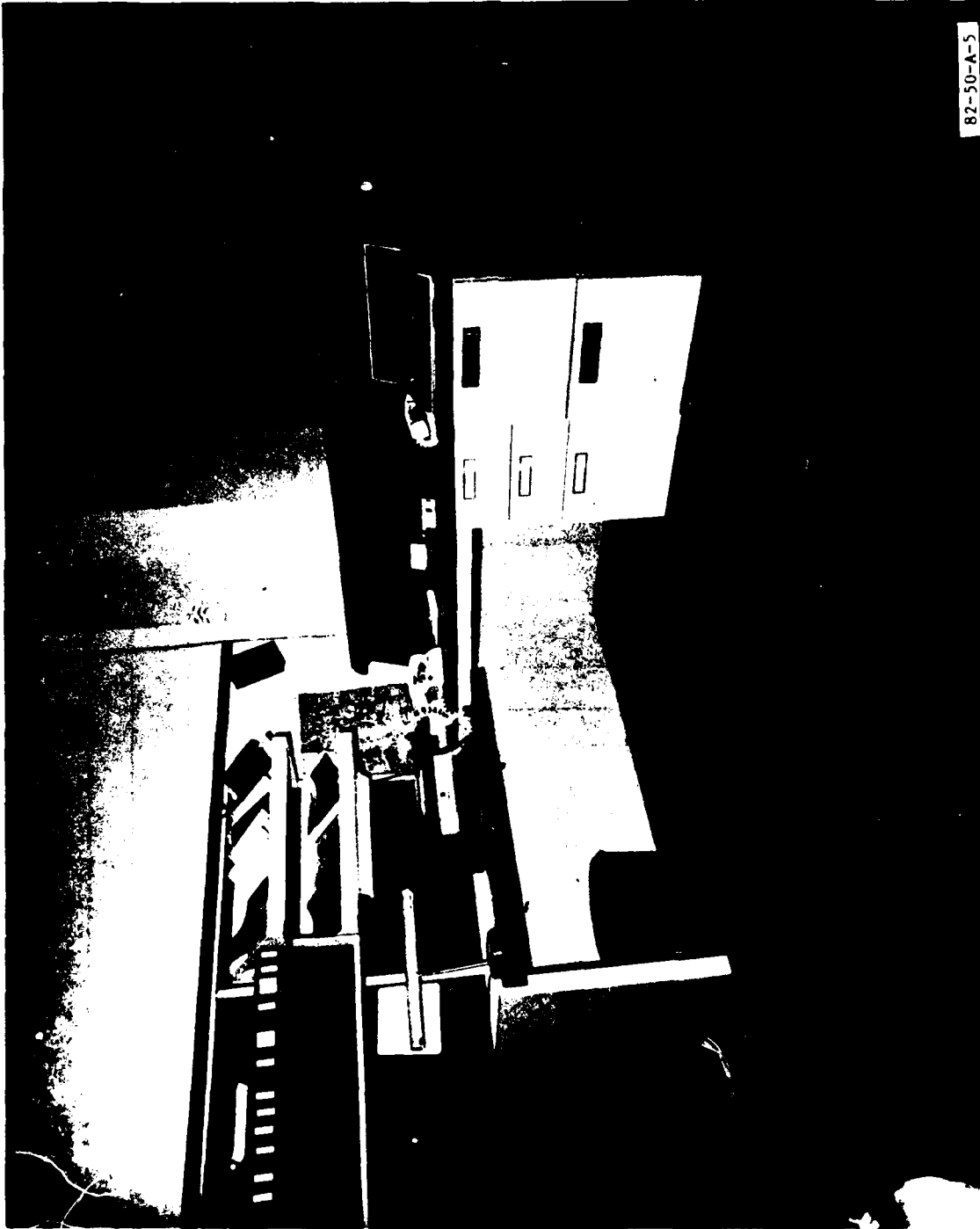

FIGURE A-5. TALLAHASSEE SUPERVISOR DESK

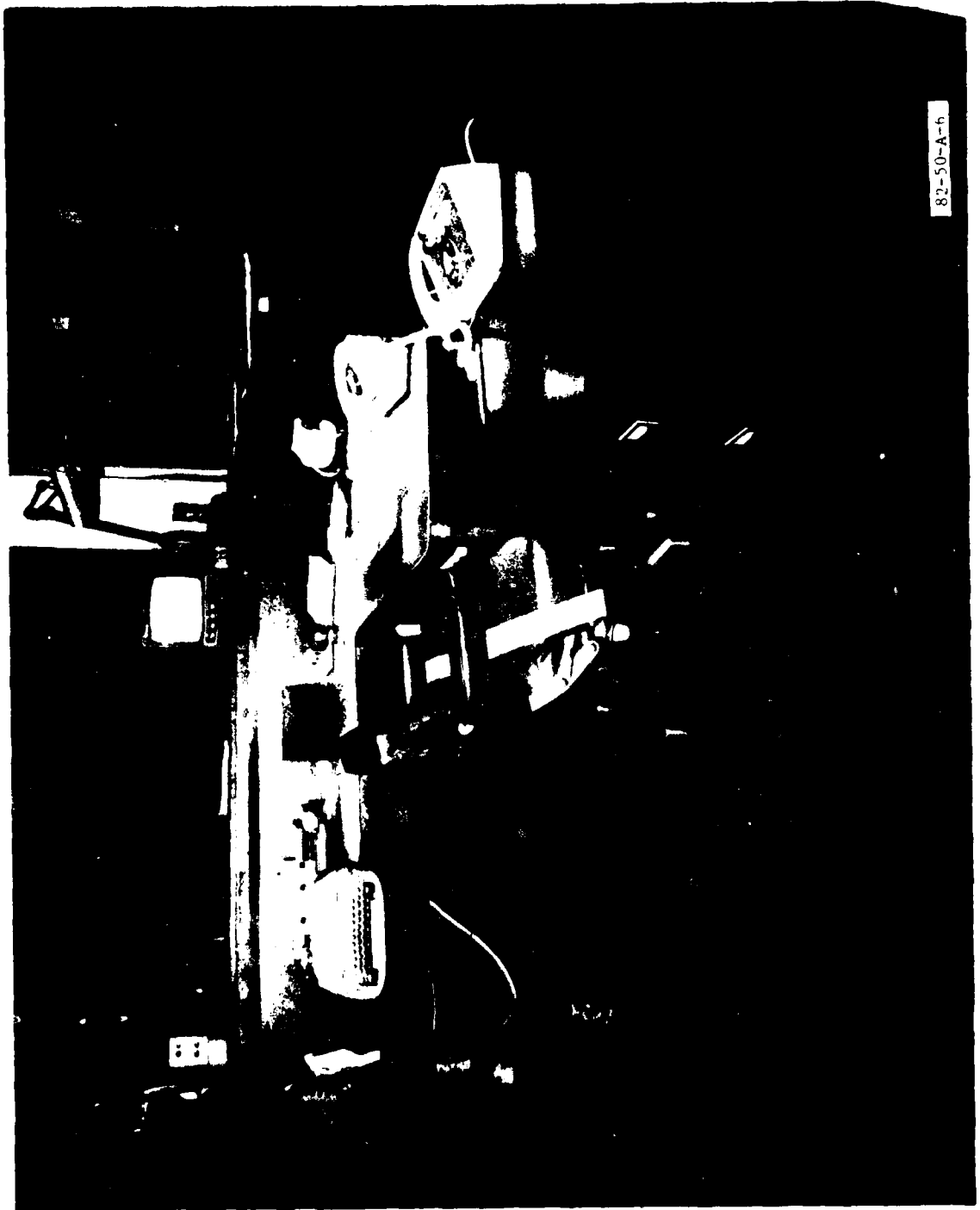

FIGURE A-6. DENVER SUPERVISOR DESK



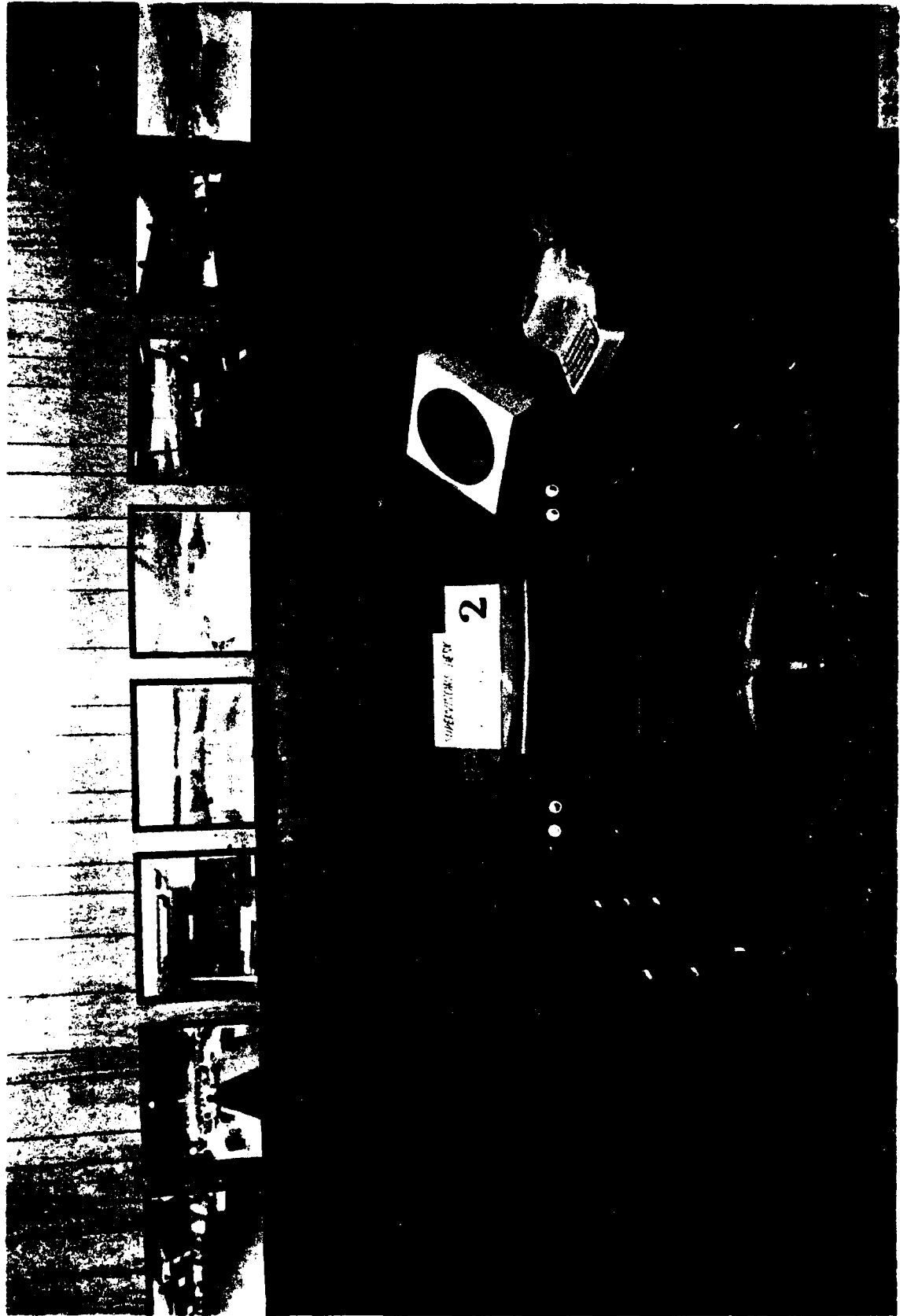

FIGURE A-8. WINDSOR LOCKS SUPERVISOR DESK

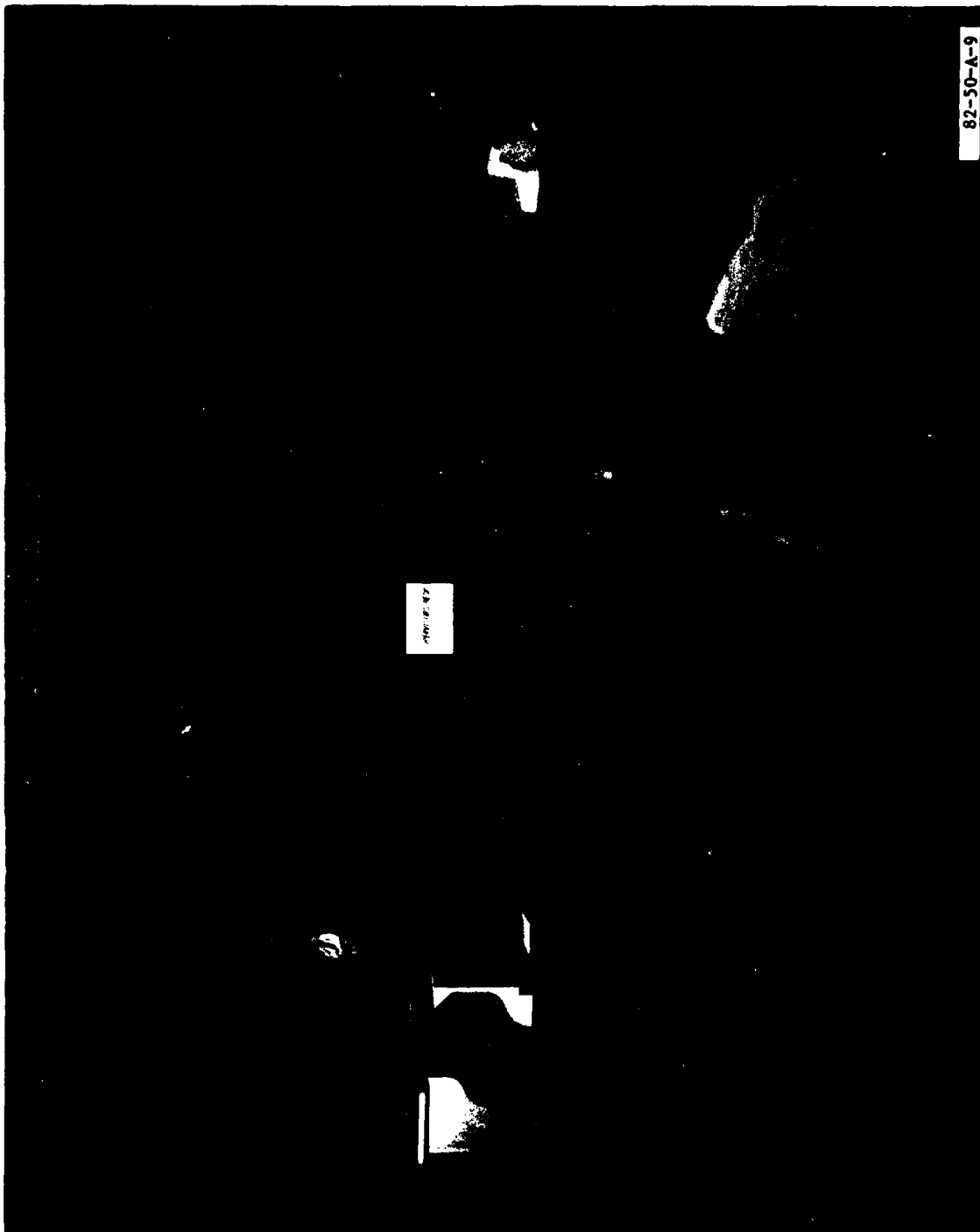

FIGURE A-9. FUTURAMA SUPERVISOR DESK CONCEPT

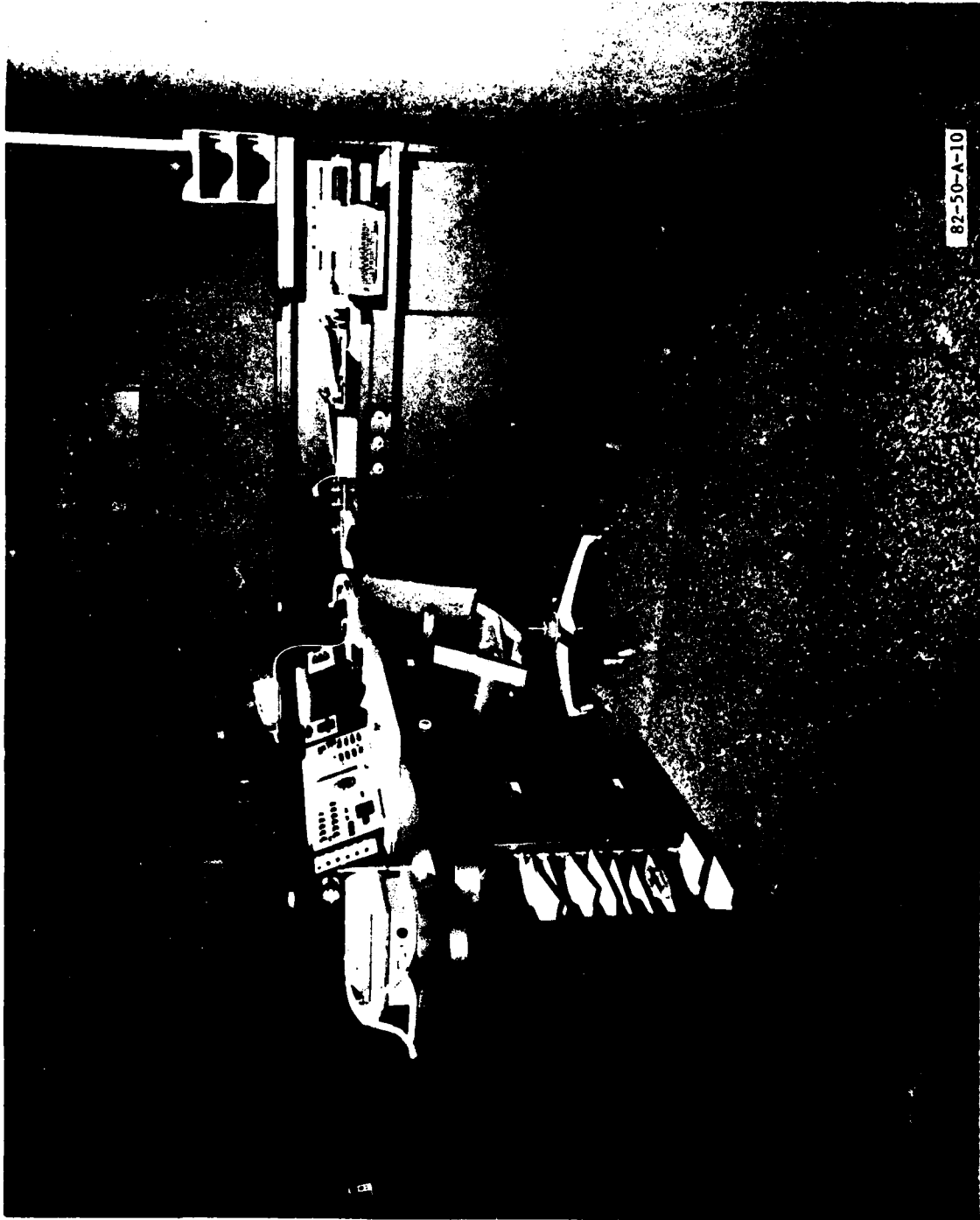
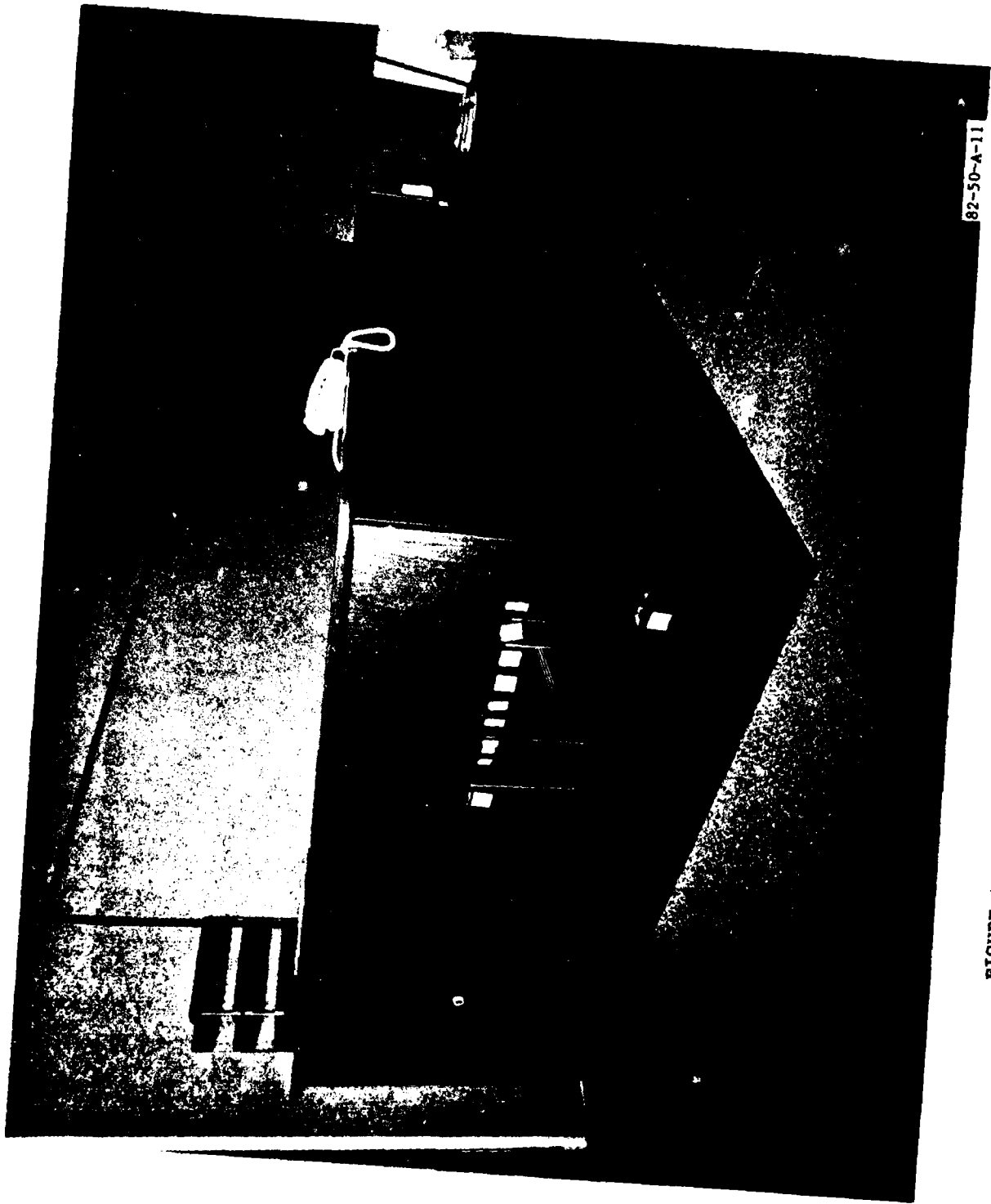

FIGURE A-10. COLORADO SPRINGS SUPERVISOR DESK, FRONT VIEW



82-50-A-11

FIGURE A-11. COLORADO SPRINGS SUPERVISOR DESK, BACK VIEW

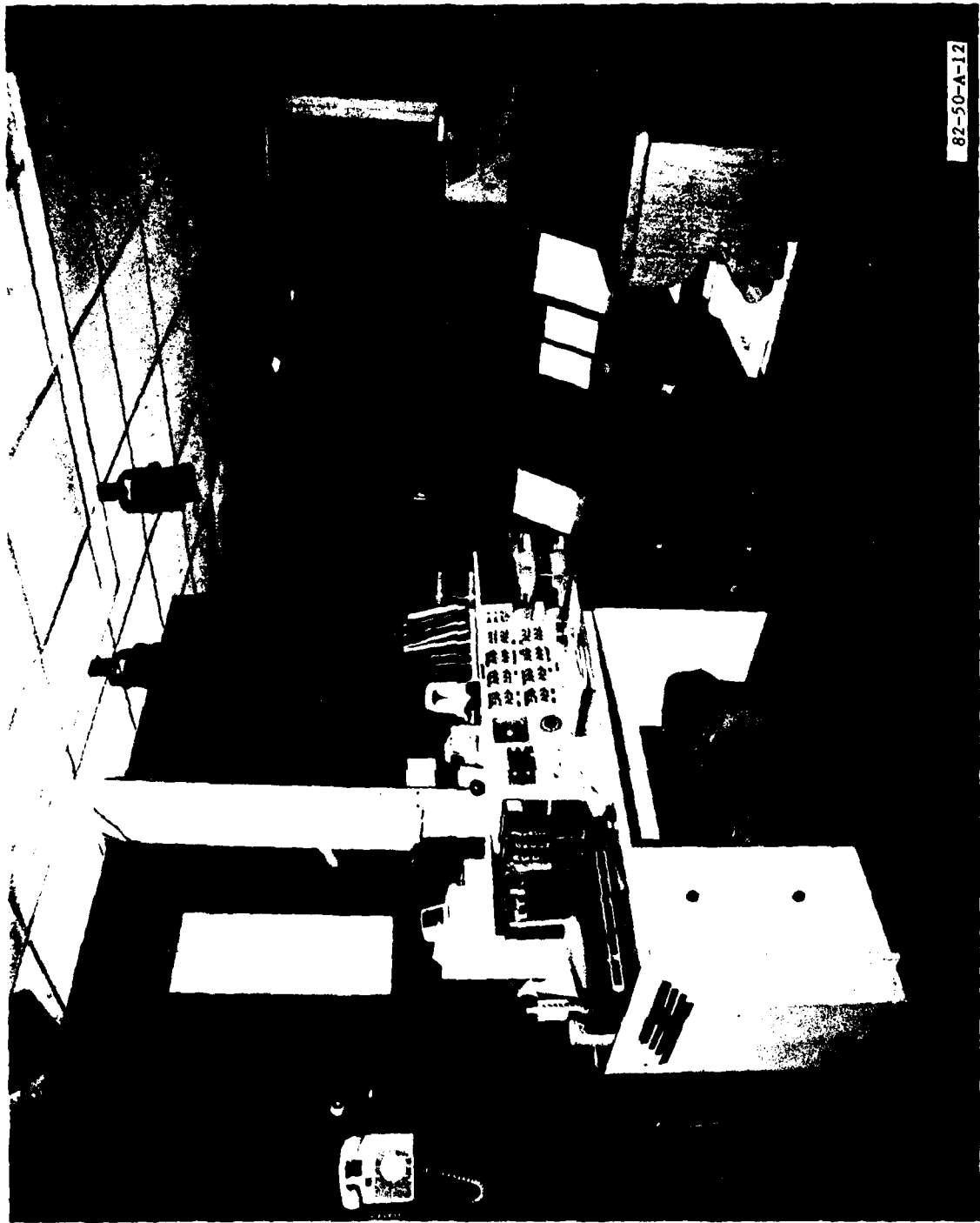

FIGURE A-12. BALTIMORE SUPERVISOR DESK, LEFT SIDE



FIGURE A-13. BALTIMORE SUPERVISOR DESK, RIGHT SIDE



82-50-A-14

FIGURE A-14. BALTIMORE SUPERVISOR DESK, BACK VIEW



82-50-A-15

FIGURE A-15. DULLES SUPERVISOR DESK, LEFT SIDE



FIGURE A-16. DULLES SUPERVISOR DESK, RIGHT SIDE



FIGURE A-17. DULLES SUPERVISOR DESK, BACK VIEW

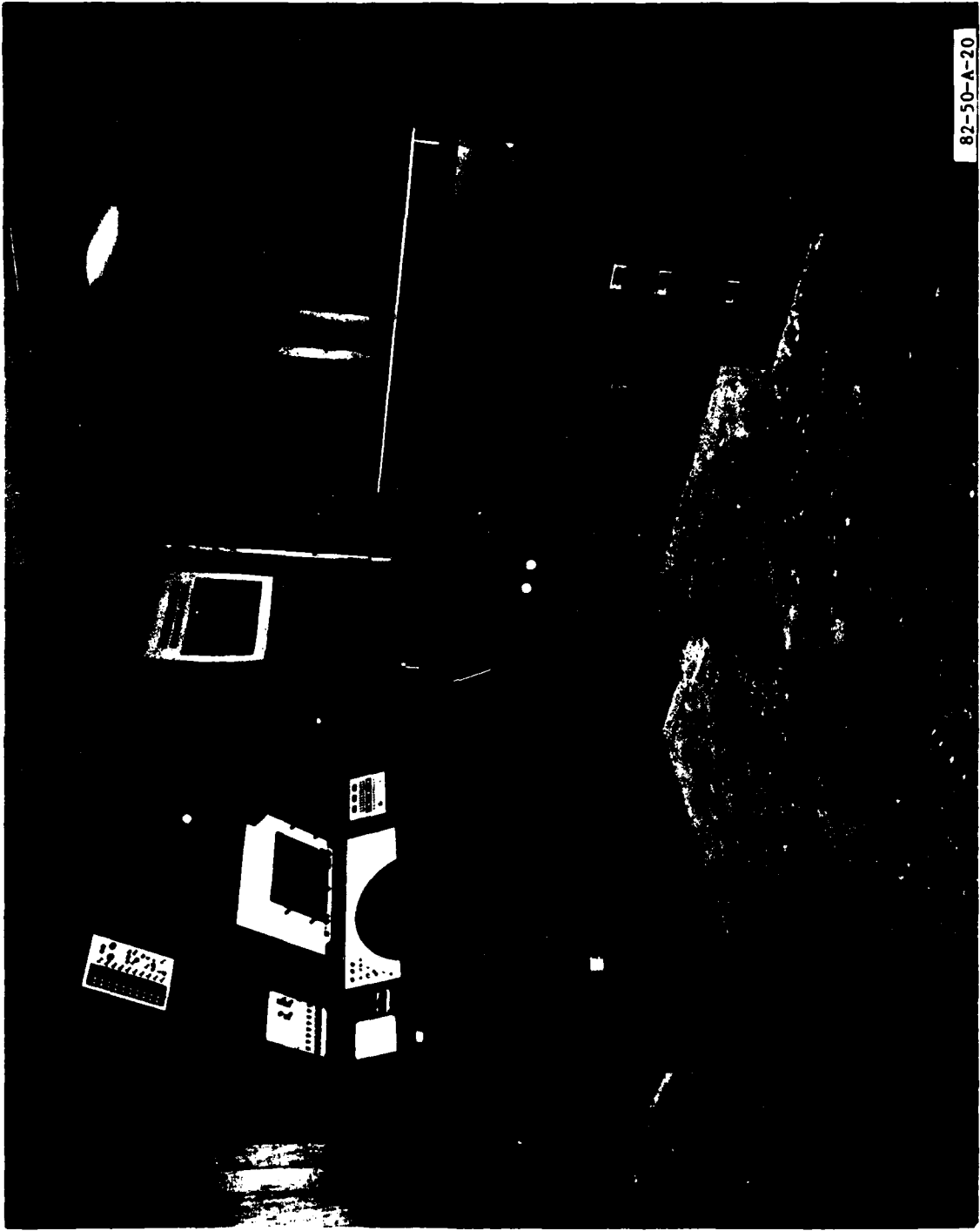

FIGURE A-18. SOUTH BEND SUPERVISOR DESK, FRONT VIEW



82-50-A-19

FIGURE A-19. SOUTH BEND SUPERVISOR DESK, BACK VIEW



82-50-A-20

FIGURE A-20. CHARLOTTE SUPERVISOR DESK, FRONT VIEW

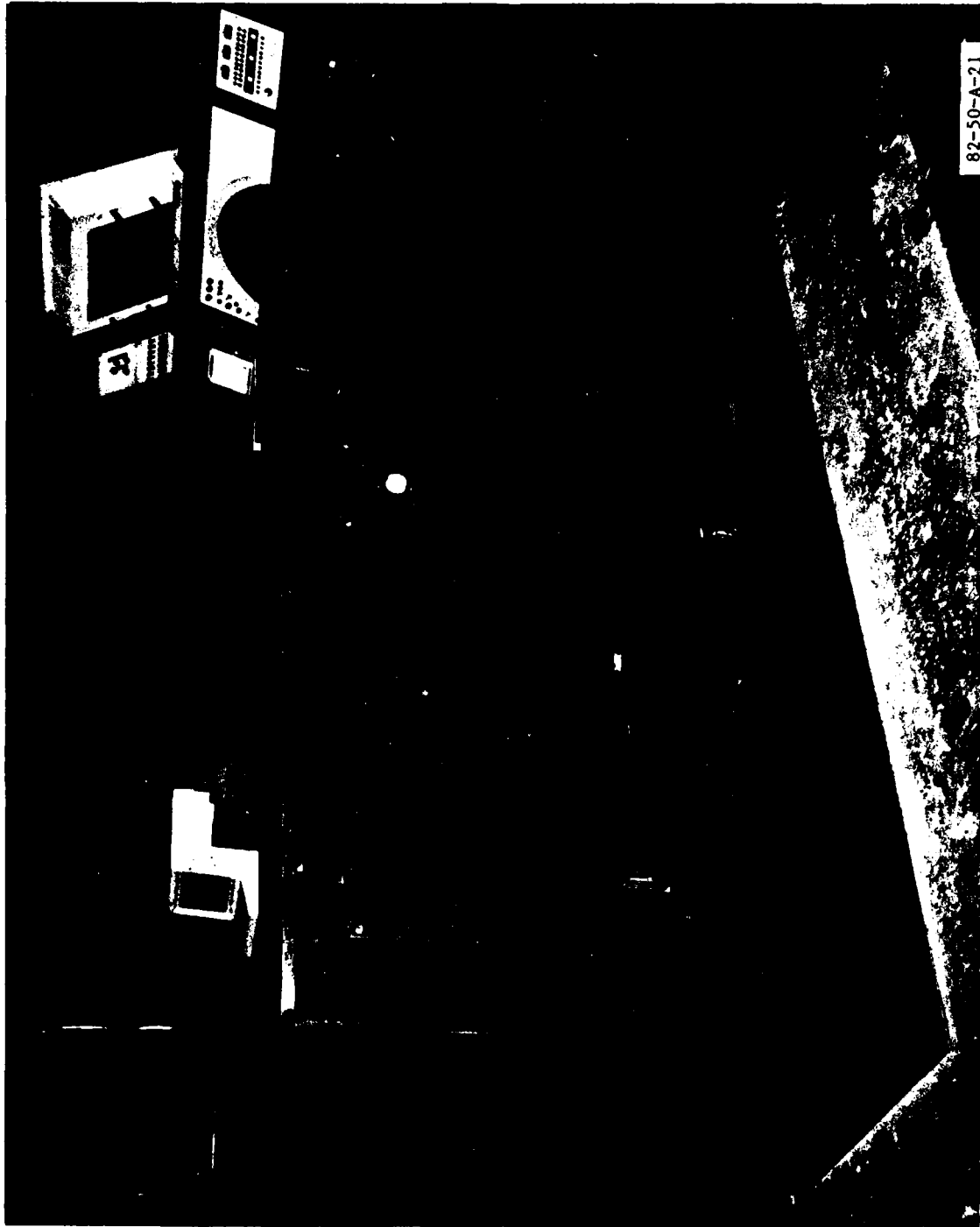

FIGURE A-21. CHARLOTTE SUPERVISOR DESK, BACK VIEW



FIGURE A-22. BURBANK SUPERVISOR DESK, MAIN CONSOLE

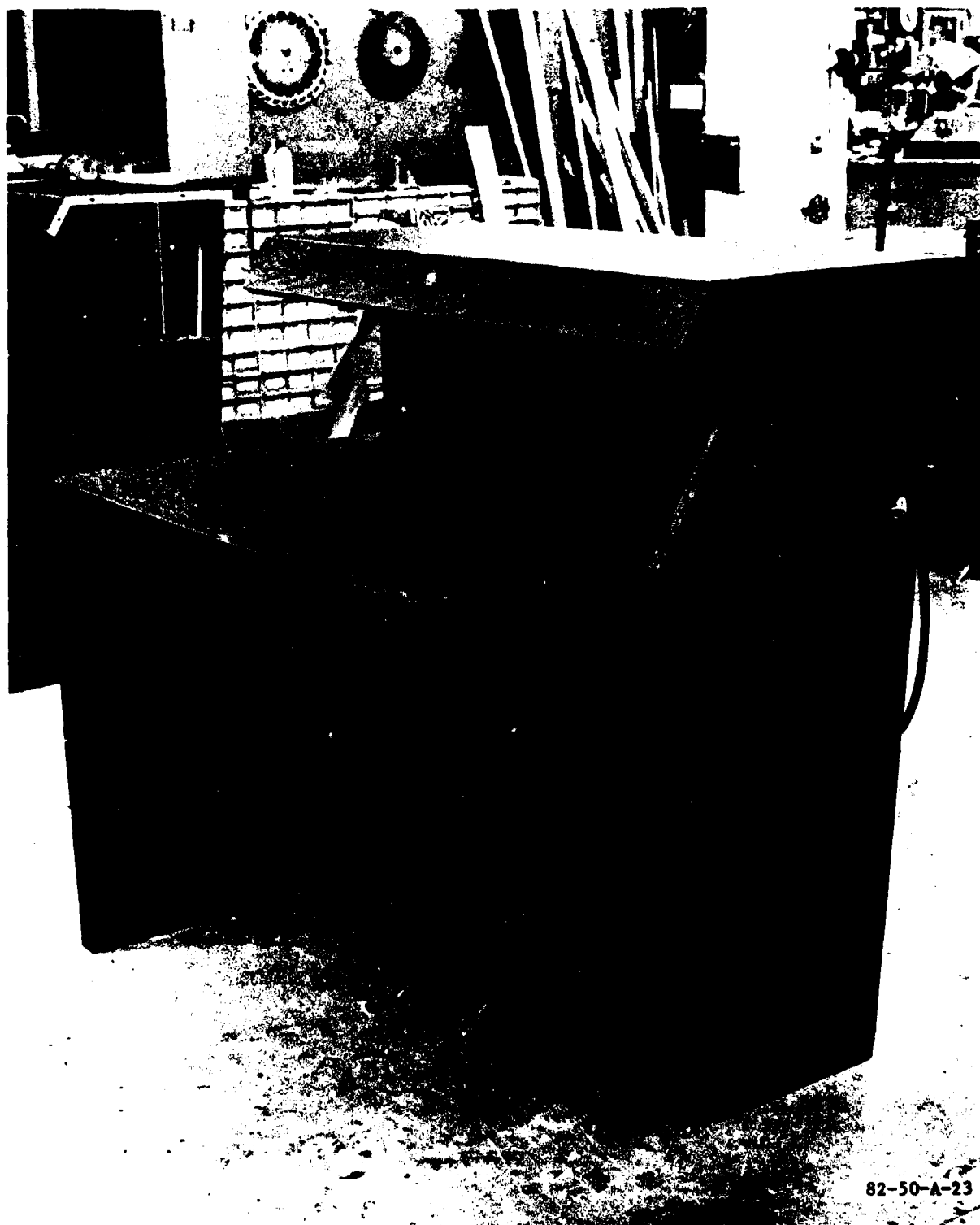
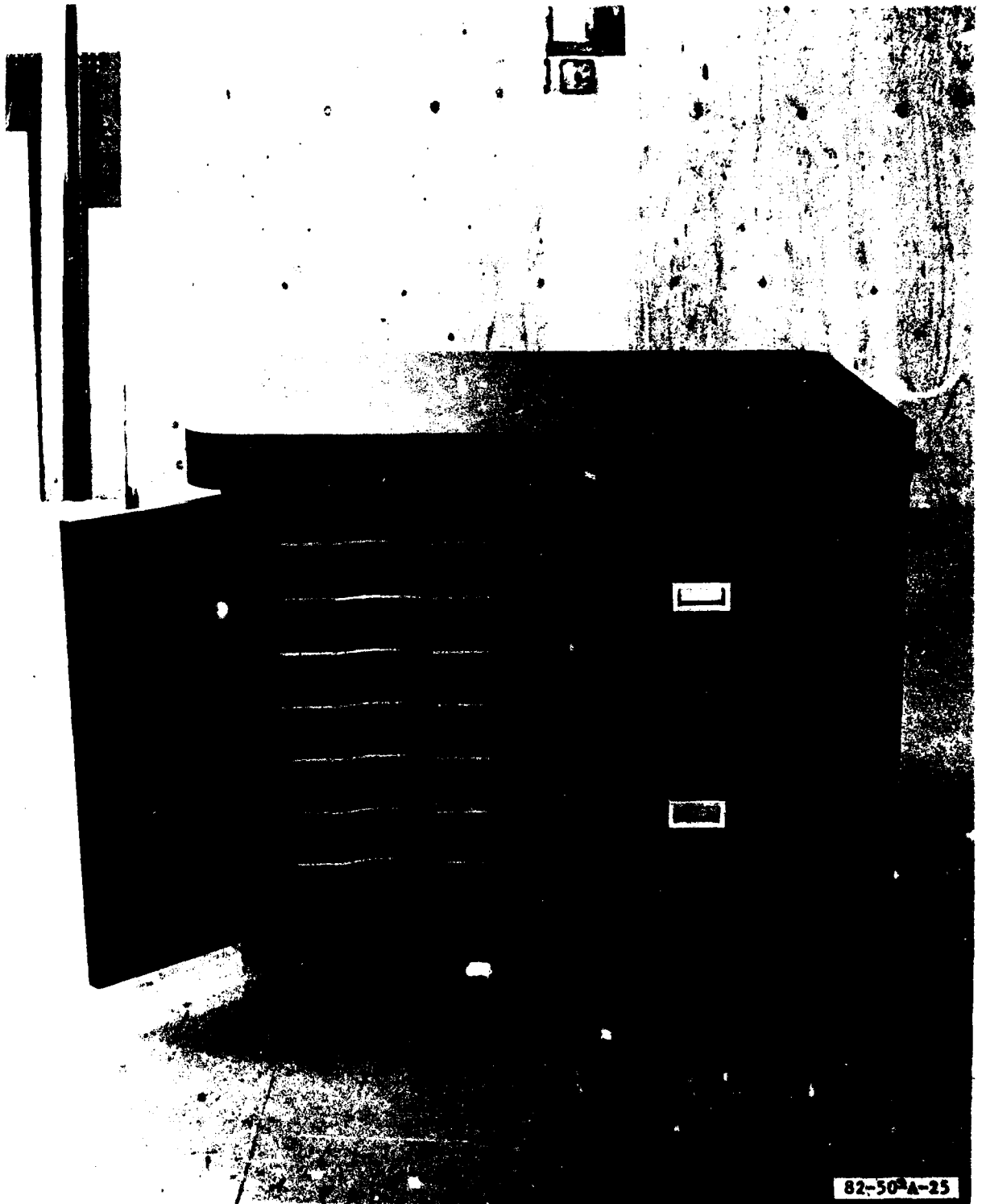

FIGURE A-23. BURBANK SUPERVISOR DESK, MAIN PEDESTAL



82-50-A-24

FIGURE A-24. BURBANK SUPERVISOR DESK, CORNER CONSOLE



82-50-A-25

FIGURE A-25. BURBANK SUPERVISOR DESK, TYPEWRITER CONSOLE



FIGURE A-26. BURBANK SUPERVISOR DESK ASSEMBLED

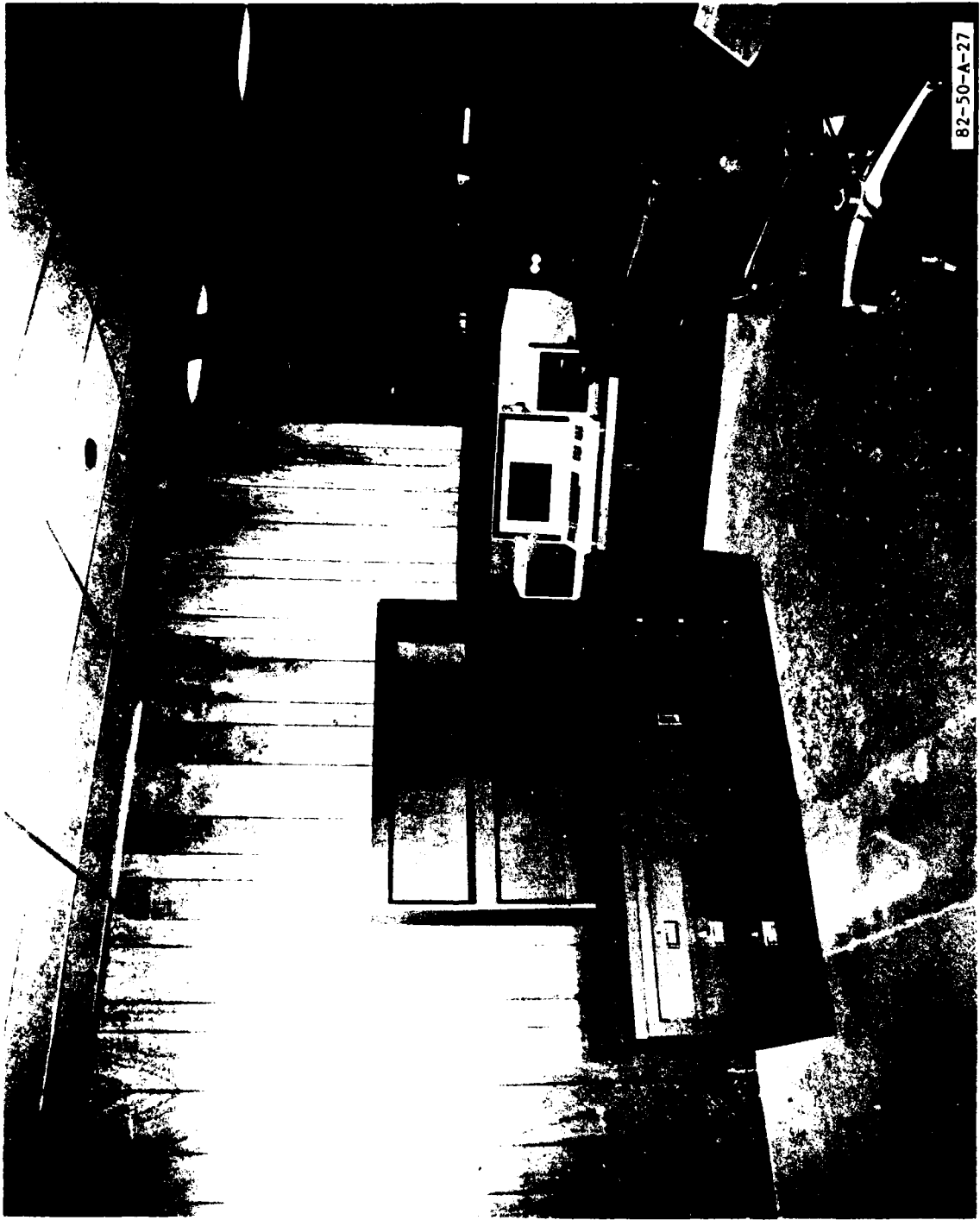

FIGURE A-27. PHILADELPHIA SUPERVISOR DESK, LEFT VIEW



FIGURE A-28. PHILADELPHIA SUPERVISOR DESK, RIGHT VIEW



FIGURE A-29. PHILADELPHIA SUPERVISOR DESK, BACK VIEW

## APPENDIX B

### DRAWINGS AS PROPOSED FOR MODULAR SUPERVISORY DESKS

The initially sketched drawings of the desk modules developed and evaluated under Project No. 219-151-150, Supervisory Desk Complex Development, are contained in this appendix.

Details shown on these drawings provide general construction techniques which allowed shop drawings to be made by the supplier and reviewed during the procurement cycle. Changes were made during construction and after construction during evaluation. Appendix C contains the final construction drawings.









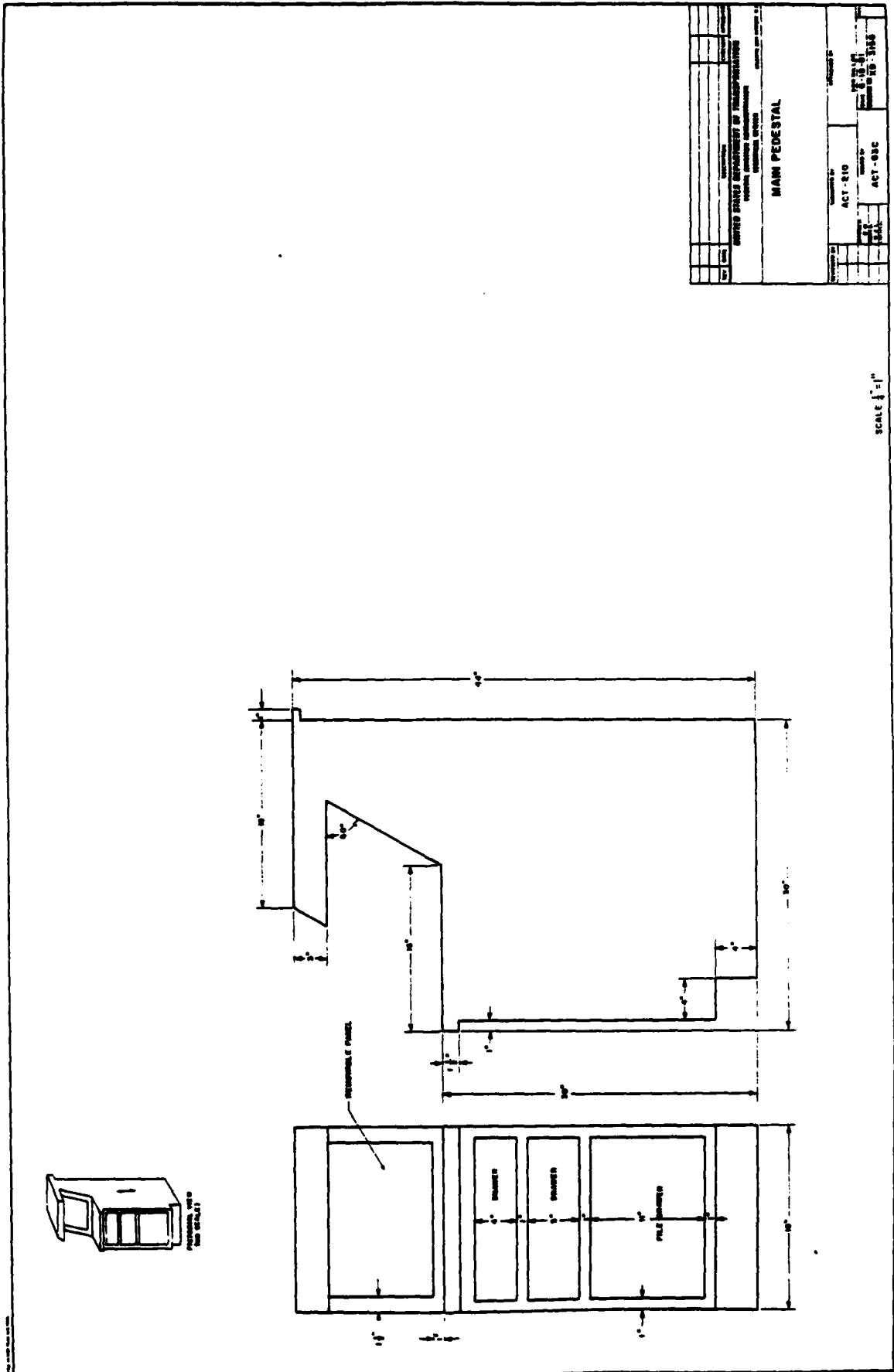
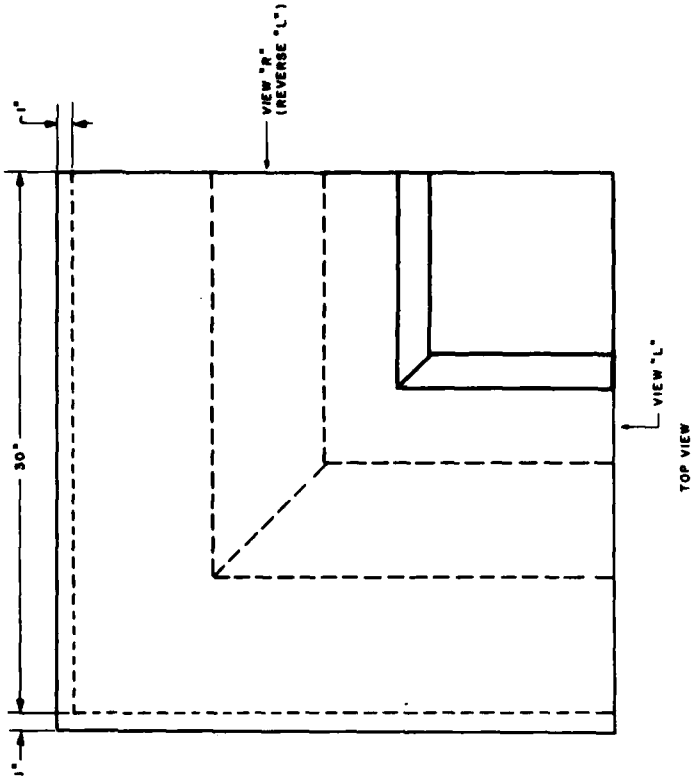
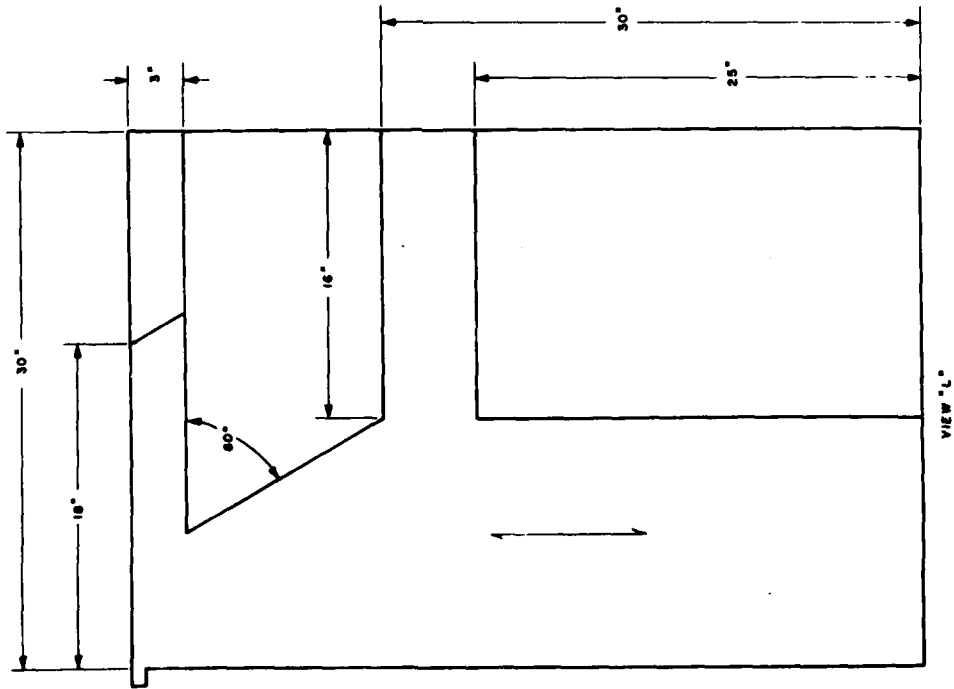
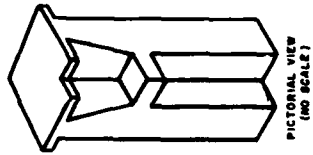

FIGURE B-5. MAIN PEDESTAL



82-50-B-6

FIGURE B-6. 90° CORNER CONSOLE

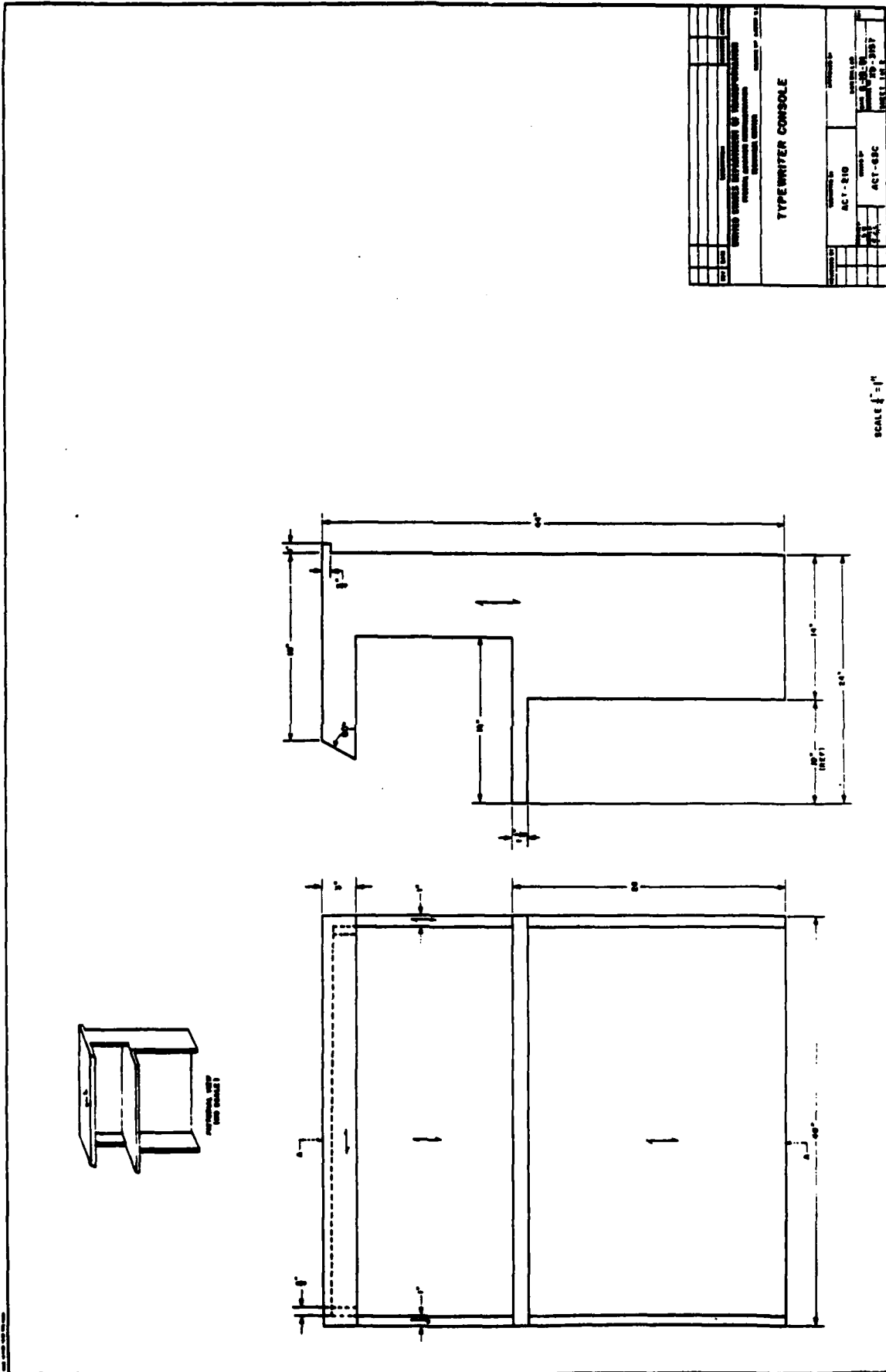
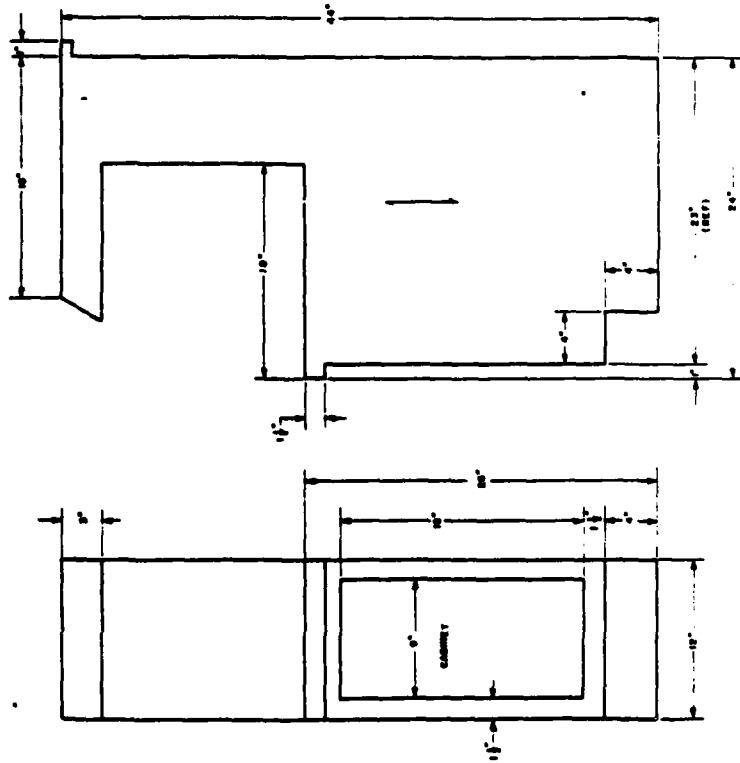
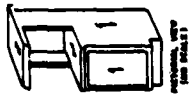

FIGURE B-7. TYPEWRITER CONSOLE, EXTERIOR VIEWS





SCALE 1/2" = 1"

UNITED STATES DEPARTMENT OF TRANSPORTATION	
TECHNICAL SERVICE	
TYPEWRITER PEDESTAL	
DESIGNED BY	ACT-810
DATE	APR 19 1950
BY	ACT-830
REVISION	ACT-830
APPROVED BY	
DATE	

FIGURE B-9. TYPEWRITER PEDESTAL

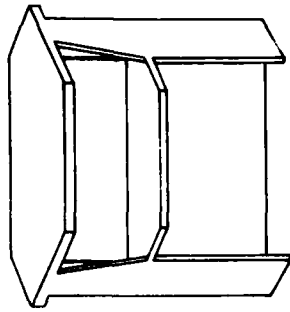

PICTORIAL VIEW  
(NO SCALE)

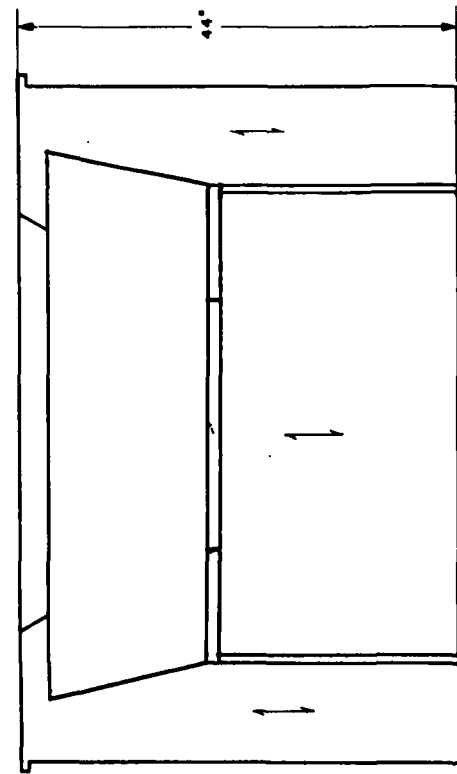
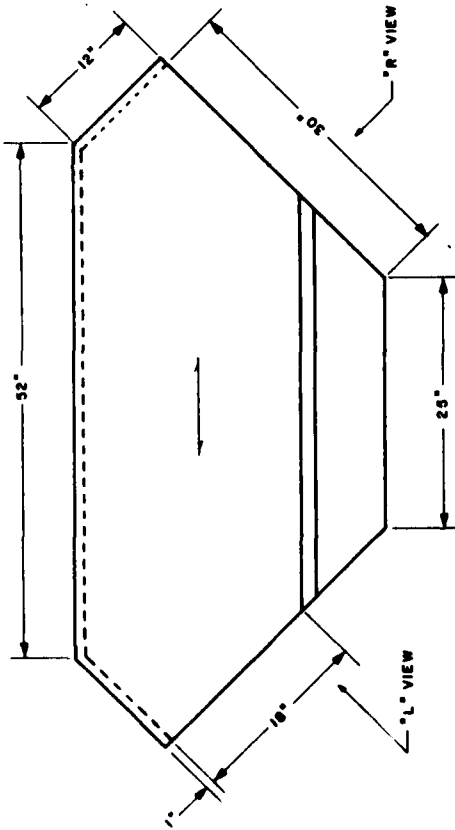

VIEW "R" (REVERSE "L")

82-50-B-10

FIGURE B-10. 45° CORNER CONSOLE



**APPENDIX C**

**DETAILED DRAWINGS OF THE FINAL SUPERVISOR DESK MODULAR DESIGN**

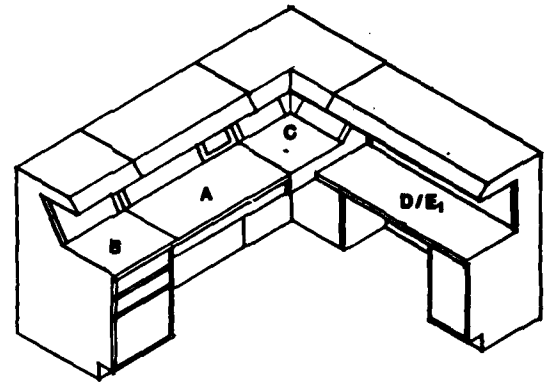
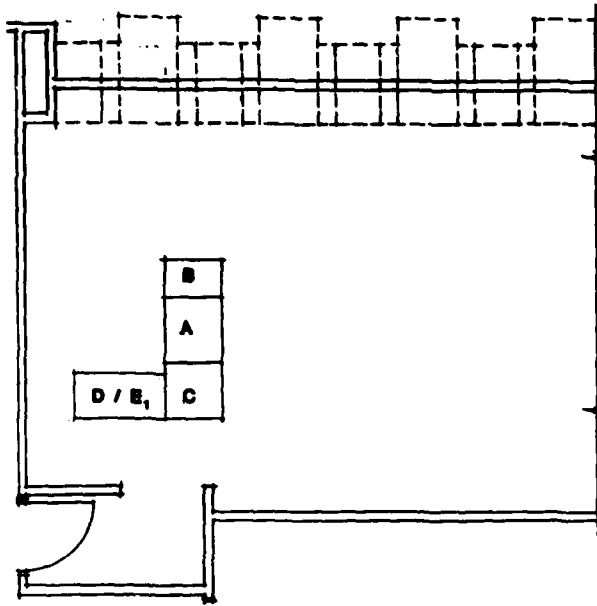

**INTERMEDIATE ACTIVITY LEVEL  
8,000 SQ. FT. BASE BUILDING**

DRAWING SERIES NO. E-0180

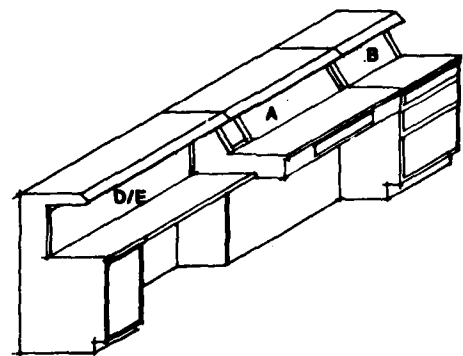
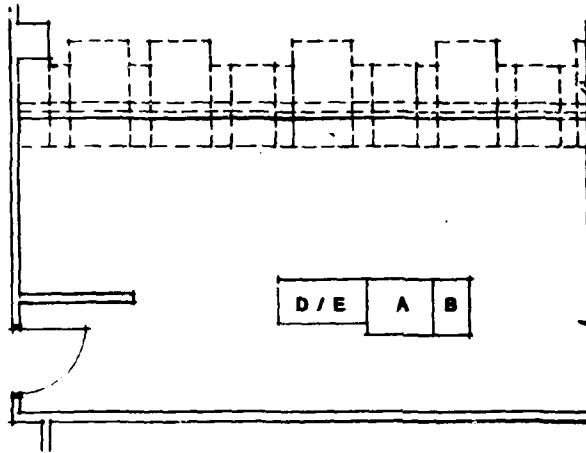

**INTERMEDIATE ACTIVITY LEVEL  
5,000 SQ. FT. BASE BUILDING**

DRAWING SERIES NO. E-0180

FIGURE C-1. RECOMMENDED CONSOLES FOR BASE BUILDING SIZES OF 5,000 AND 8,000 SQ. FT.

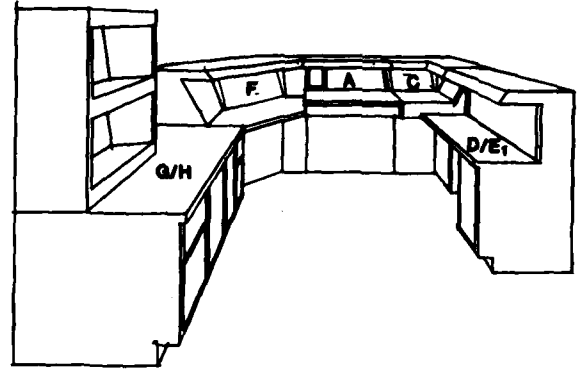
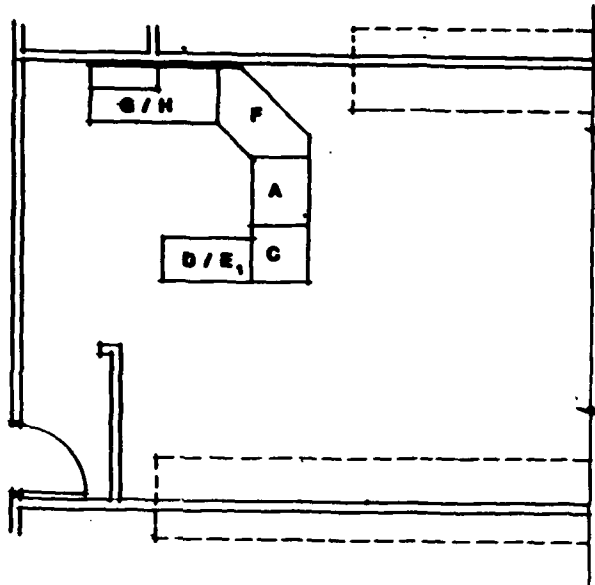

**MAJOR ACTIVITY LEVEL**  
**14,500 SQ. FT. BASE BUILDING**  
 DRAWING SERIES NO. E-9079

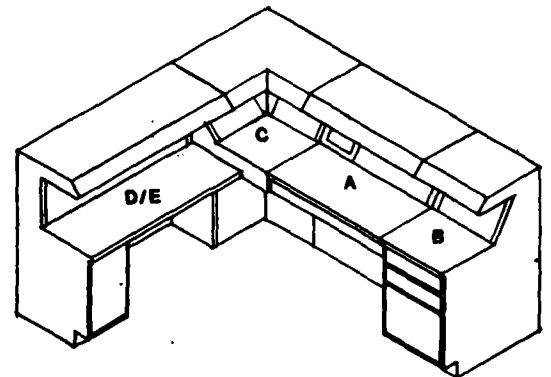
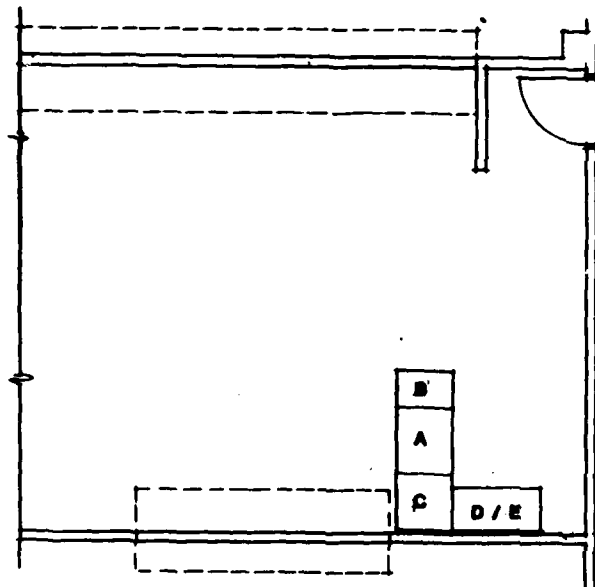

**MAJOR ACTIVITY LEVEL**  
**11,000 SQ. FT. BASE BUILDING**  
 DRAWING SERIES NO. E-9199

**FIGURE C-2. RECOMMENDED CONSOLES FOR BASE BUILDING SIZES OF 11,000 AND 14,500 SQ. FT.**

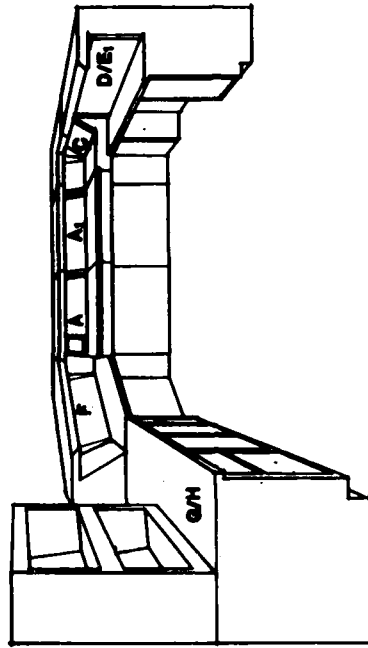
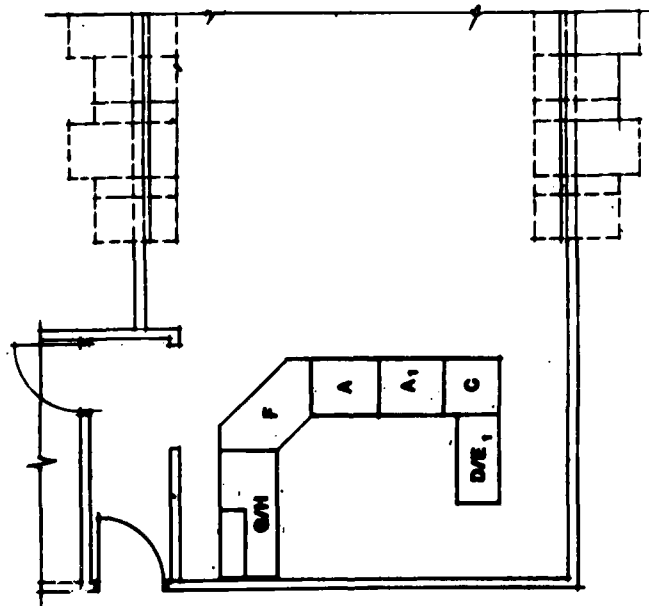

**MAJOR ACTIVITY LEVEL**  
**20,000 SQ. FT. BASE BUILDING**  
 DRAWING SERIES NO. B-6100

FIGURE C-3. RECOMMENDED CONSOLE FOR BASE BUILDING SIZE OF 20,000 SQ. FT.

# STANDARD ABBREVIATIONS

<p>AL ALUMINUM</p> <p>ALT ALTERNATE</p> <p>BLKG BLOCKING</p> <p>C CONDUIT</p> <p>DET DETAIL</p> <p>DIM DIMENSION</p> <p>FIXT FIXTURE</p> <p>GA GAUGE</p> <p>HWD HARDWOOD</p> <p>MTL METAL</p> <p>NTS NOT TO SCALE</p>	<p>P PAINT</p> <p>PLAM PLASTIC LAMINATE</p> <p>PLYWD PLYWOOD</p> <p>R RADIUS</p> <p>REV REVERSE</p> <p>SHT SHEET</p> <p>SIM SIMILAR</p> <p>SW SWITCH</p> <p>TYP TYPICAL</p> <p>WD WOOD</p>
-----------------------------------------------------------------------------------------------------------------------------------------------------------------------------------------------------------------------	--------------------------------------------------------------------------------------------------------------------------------------------------------------------------------------------

## GENERAL LEGEND









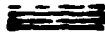

SYMBOL	DESCRIPTION	SYMBOL	DESCRIPTION
	WOOD BLOCKING		DUPLEX RECEPTACLE
	PLYWOOD		"J" BOX
	PLASTIC LAMINATE		BRANCH CIRCUIT
	HARDWOOD		TRACK LIGHT FIXTURE
			DIMMER SWITCH
			BRANCH CIRCUIT DOWN

FIGURE C-4. STANDARD ABBREVIATIONS AND GENERAL LEGEND

## MILLWORK

### A. General

1. All millwork shall conform to the Premium Grade requirements of the "AWI Quality Standards, Section 400" for high pressure laminates. Particle board will not be allowed.
2. All hardware and electrical items as shown on the drawings and specified, shall be furnished and installed. All electrical connections shall be completed in accordance with national, state, and local codes.
3. Manufacturer shall provide shop drawings to the Contracting Officer.
4. All items shall be of the make and manufacturer specified or approved equals.

### B. Materials

1. Hardwood plywood shall be 3/4" thick except as noted and conform to the requirements of Product Standard PS 51 and bear the Grade-Trademark.
2. Hardwood for painted finish shall be birch or yellow poplar, unselected for color or grain. Use clean finish wood, with no visible defects.
3. High-pressure laminate shall meet the minimum standards for laminate of National Electric Manufacturers' Association "Publication No. LD3", as well as all applicable U.S. Government specifications. All plastic laminate shall be Formica gunstock walnut #492-65 (MATT) finish, 1/16" thick. All laminate grain shall run in the same direction, parallel to the consoles length, unless noted otherwise.
4. Paint materials shall be manufactured by Pittsburgh Paint. Pratt and Lambert or Glidden are acceptable.
5. Paint colors shall be as follows: P-1 Cafe Noir, PPG #N 7064 at all wood interior and semi-exposed surfaces and as noted on the drawings. P-2 Blossom White, PPG #P 2537 at light fixture reflectors.
6. Shelf Standards: SS-1 Knap & Vogt #255 w/#256 supports.
7. Door Catches: DC-1 Stanley #35.
8. Cam Locks: National Lock #8053. (Locks at access panels and front panels with locking discs removed.)
9. Hinges: Stanley #1585 (2-1/2") US260.
10. File Follower: FF-1 Knap & Vogt #476, cut track to required length.
11. Drawer Slides: DS-1 Grant #511, DS-2 Grant #3359.
12. Case Fastener: CF-1 Rondorfix by Hafele America Corp. High Point, NC. CF-2 Knap & Vogt #516 Tite Joint fastener.
13. Vinyl "T" Edging: Shall be manufactured by Plastiglide, Hawthorne, CA., and as dimensioned on the drawings. Color shall be Dark Walnut.
14. Drawer & Door Pulls: Plastiglide 142-3740 in Dark Walnut to match Vinyl "T" Edging.
15. Light Fixtures: Shall be "Lytetrim" by Light Olier. Type A - #8371 w/2-#8351-15T6; Type B - #8373 w/3-#8351-15T6; Type C - #8375 w/3-#8351-15T6; Type D - #8371 & 8373 w/4-#8351-15T6.

### C. Execution

1. All exposed members are to be glued using either pressure or electric wood welder. All traces of excess glue shall be removed.
2. Joint Tolerances: Per AWI Specs for Premium Grade.
3. Joints between adjoining tops which must be field assembled shall be shop prepared with bolt up type fasteners.
4. All exposed surfaces including those face surfaces exposed when drawers and doors are opened shall be covered with plastic laminate.
5. Semi-exposed surfaces, interior surfaces, and surfaces as noted on the drawings shall be painted as specified.
6. Inspect all surfaces to be painted and perform such surface preparations as is normally required by good painting practice.
7. All drawer surfaces not covered with plastic laminate: Two coats alkyd varnish (Gloss), one coat alkyd varnish (Satin).
8. All interior millwork surfaces, painted finish: One coat, interior alkyd enamel primer or undercoat, tinted, and One coat, interior alkyd enamel.
9. Interior galvanized surfaces, unless otherwise specified: One coat, zinc dust-type primer for galvanized metal and Two coats alkyd enamel.
10. Install millwork in accordance with the appropriate typical modular supervisor console complex layout or as indicated on the architectural drawings accompanying this set. Millwork installation shall be coordinated with electrical wiring installation.
11. Shape round the cut edge of Vinyl "T" where edge is exposed at end consoles.
12. Refinish raw surfaces resulting from job fitting. Repair job-inflicted scratches and mars. Clean finished surfaces, remove excess materials and debris and leave the installation area broom clean.

FIGURE C-5. MILLWORK SPECIFICATIONS

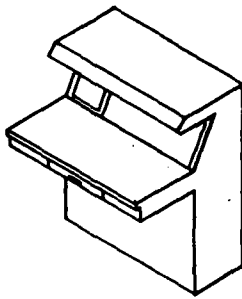

ISOMETRIC (1A)  
PRIME MAIN CONSOLE

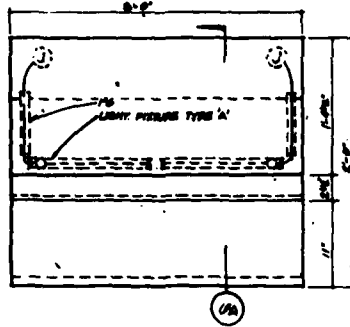

PLAN (2A)

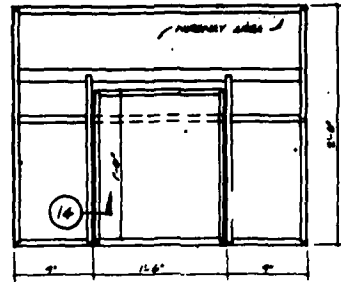

PLAN SECTION (3A)

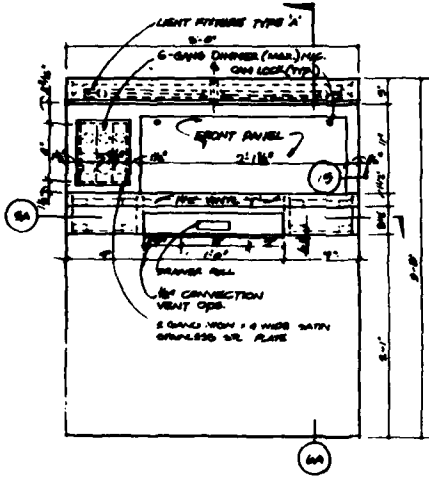

FRONT ELEVATION (4A)

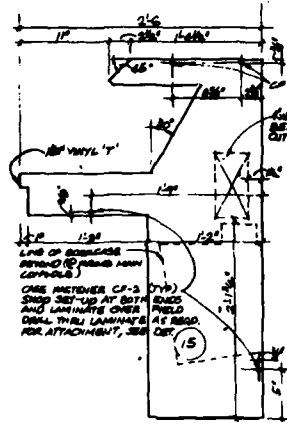

END ELEVATION (5A)

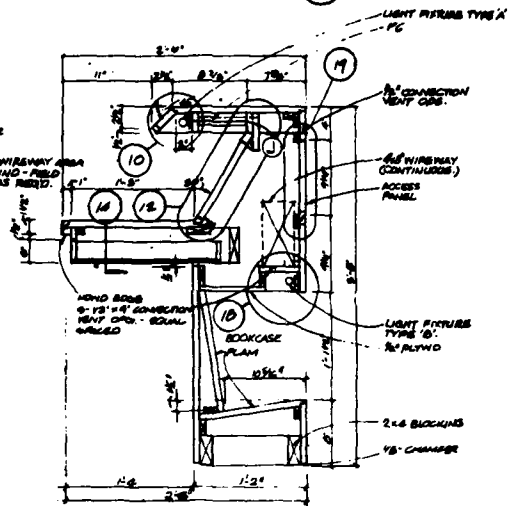

SECTION (6A)

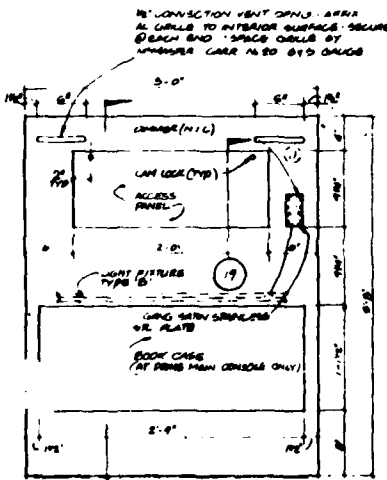

REAR ELEVATION (7A)

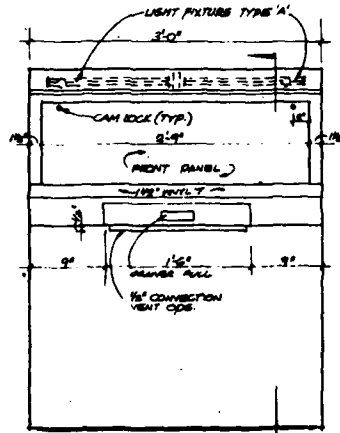

FRONT ELEVATION (8A)  
(ALT. NO. 1 MAIN CONSOLE)

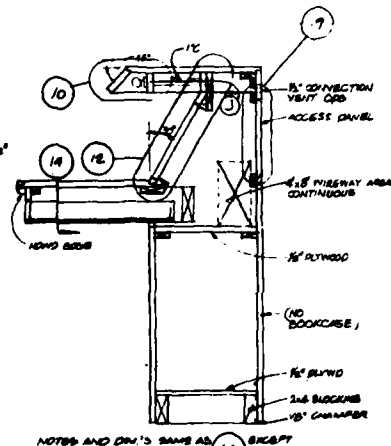

SECTION (9A)  
(ALT. NO. 1 MAIN CONSOLE)

**PRIME MAIN CONSOLE-A / MAIN CONSOLE-A1 (ALT. NO. 1)**

SCALE: 1 1/8" = 1'-0"

FIGURE C-6. PRIME MAIN CONSOLE/MAIN CONSOLE

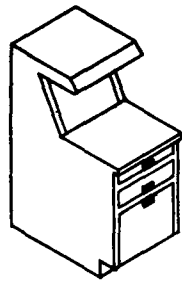

ISOMETRIC

1B

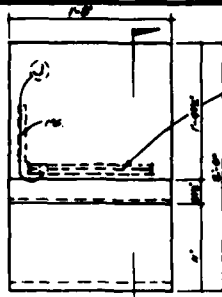

PLAN

2B

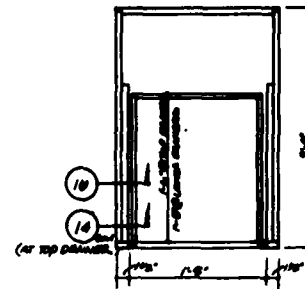

PLAN SECTION

3B

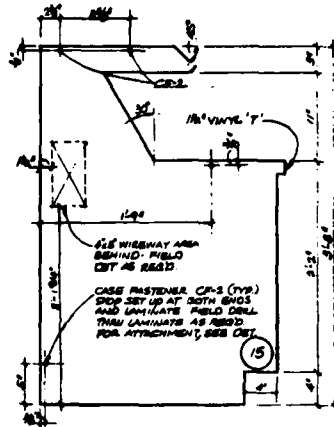

END ELEVATION

4B

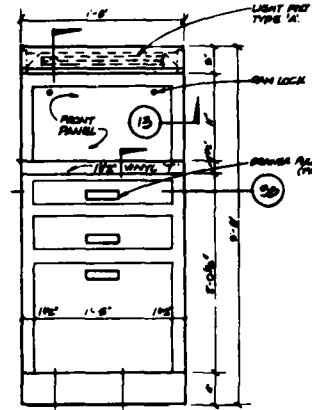

FRONT ELEVATION

5B

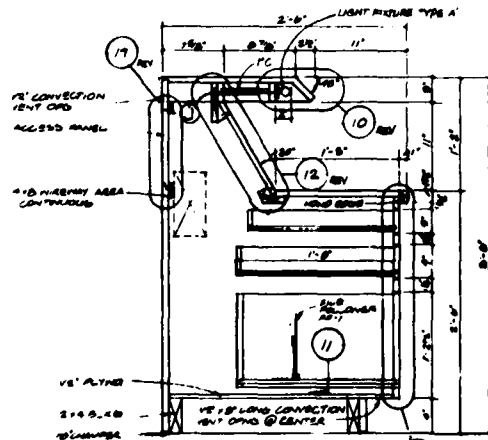

SECTION

6B

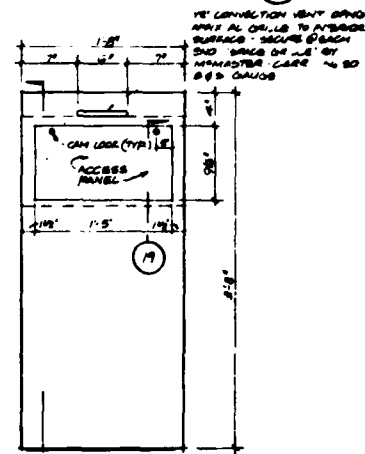

REAR ELEVATION

7B

**MAIN PEDESTAL -B**

SCALE: 1/16" = 1'-0"

FIGURE C-7. MAIN PEDESTAL

Copy available to DTIC does not permit fully legible reproduction

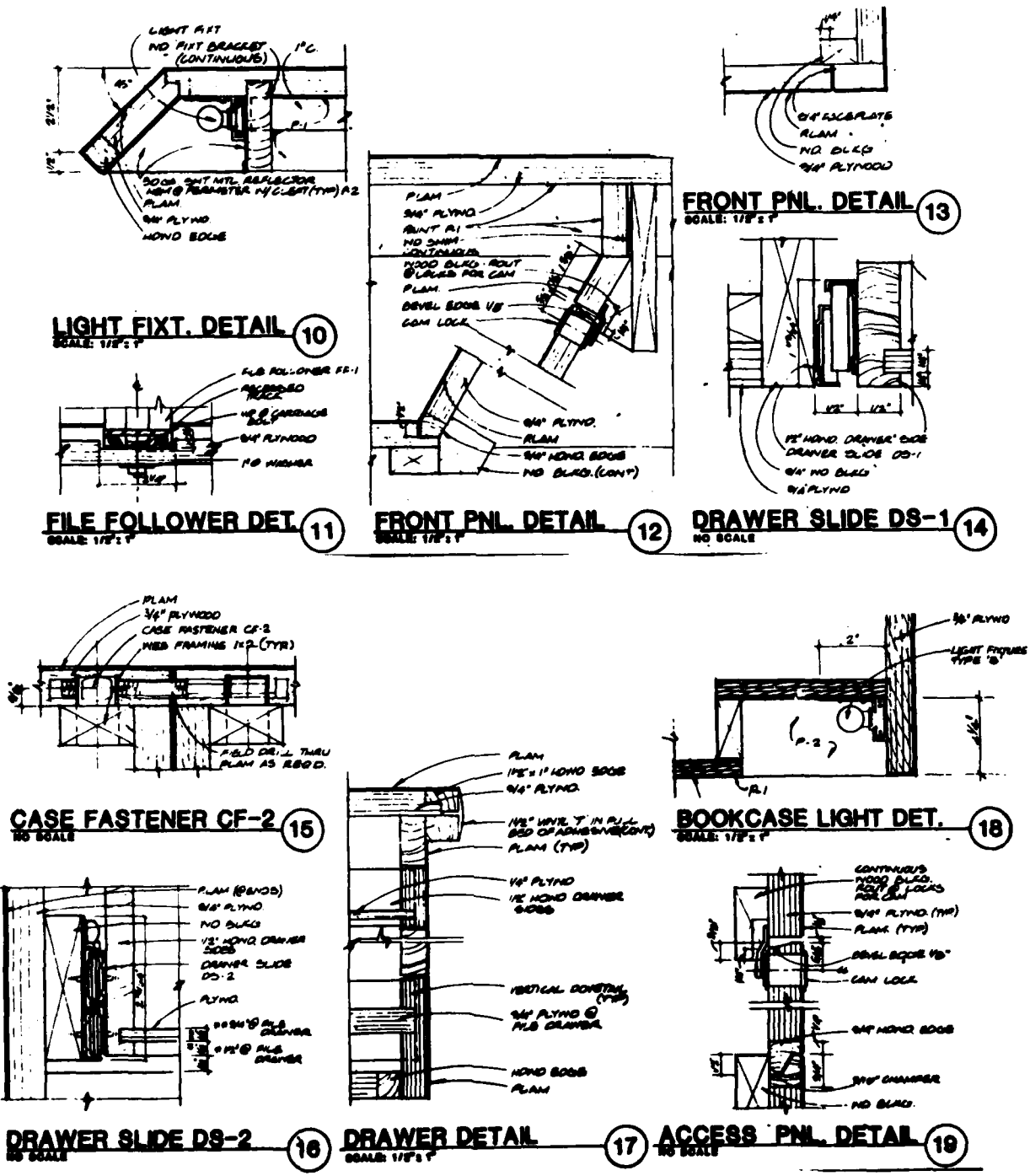
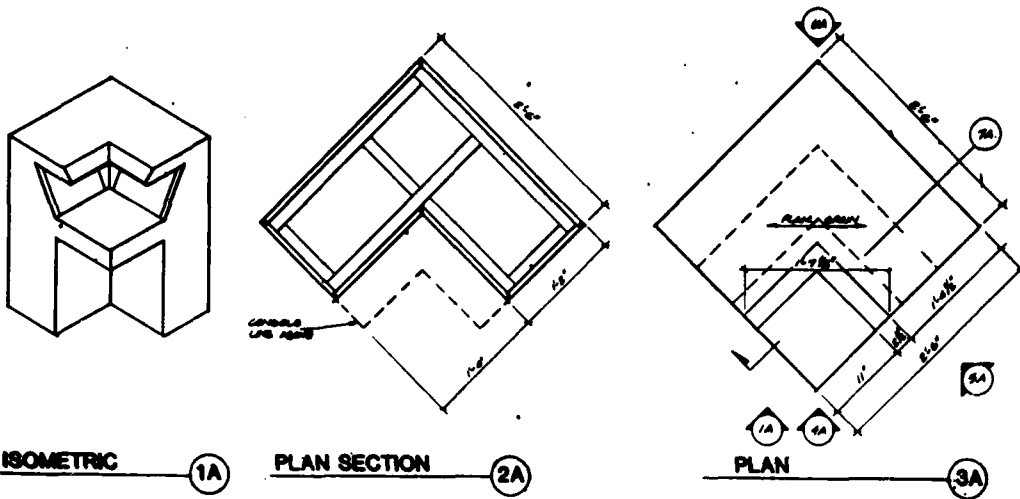

FIGURE C-8. DETAILS FOR FIGURES C-6 AND C-7

Copy available to DTIC does not  
 permit fully legible reproduction



ISOMETRIC

1A

PLAN SECTION

2A

PLAN

3A

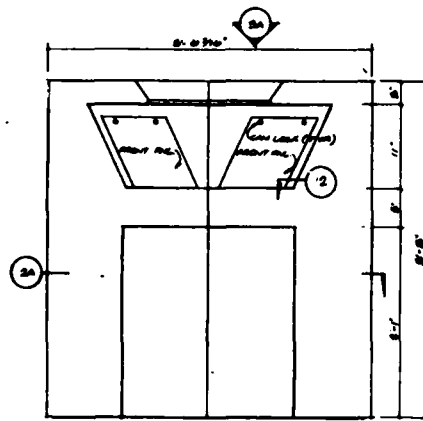

FRONT ELEVATION

4A

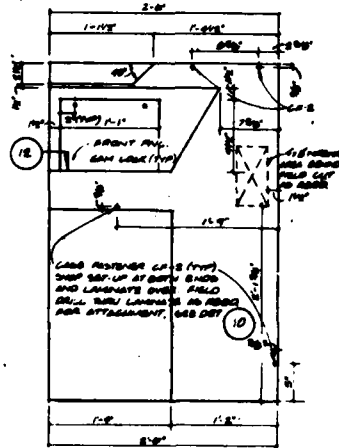

END ELEVATION

5A

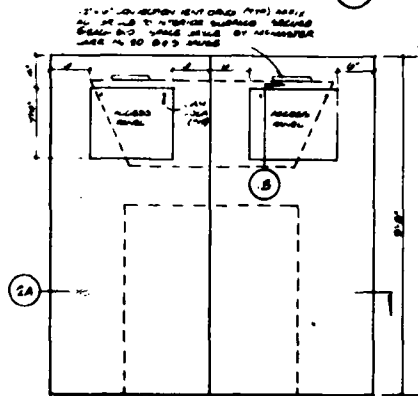

REAR ELEVATION

6A

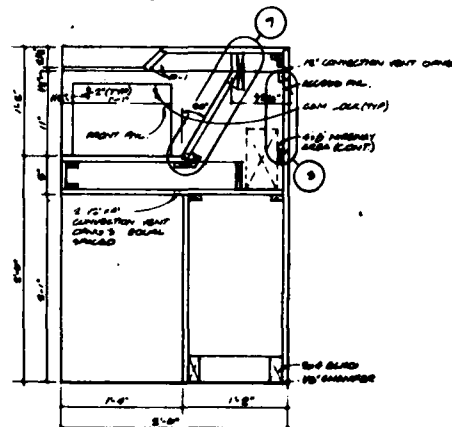

SECTION

7A

**90° CORNER CONSOLE - C**

SCALE 1/8" = 1'-0"

FIGURE C-9. 90° CORNER CONSOLE

Copy available to DDC does not permit fully legible reproduction

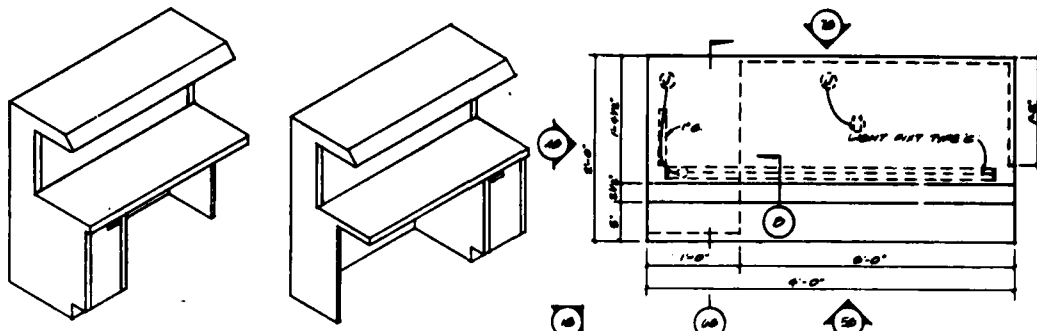

ISOMETRIC  
PEDASTAL LEFT

1B

ISOMETRIC  
PEDASTAL RIGHT

2B

PLAN

3B

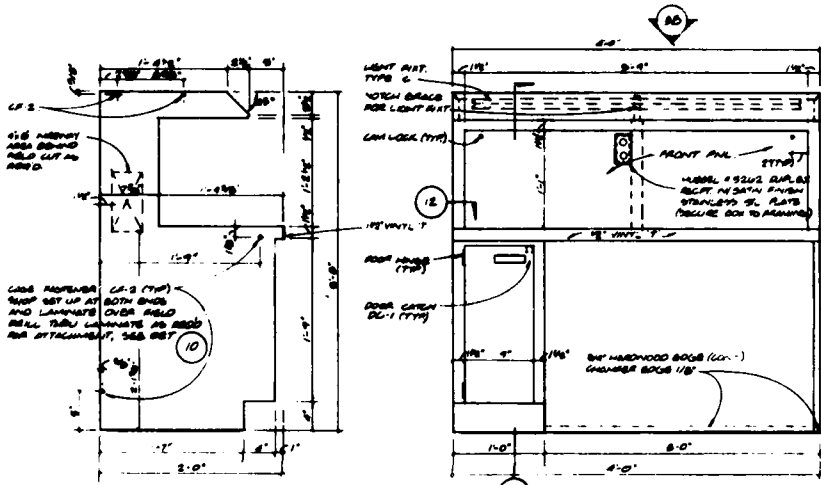

END ELEVATION

4B

FRONT ELEVATION

5B

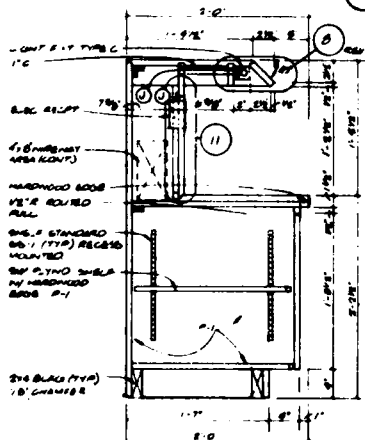

SECTION

6B

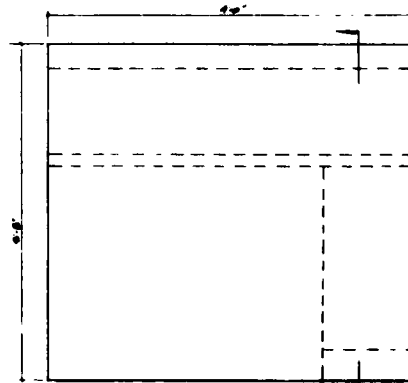

REAR ELEVATION

7B

**TYPEWRITER CONSOLE -D/E & D/E<sub>1</sub>** (ALT. NO. 1)  
SCALE 1/2" = 1'-0"

FIGURE C-10. TYPEWRITER CONSOLE

C-10

Copy available to DTIC does not  
require fully legible reproduction

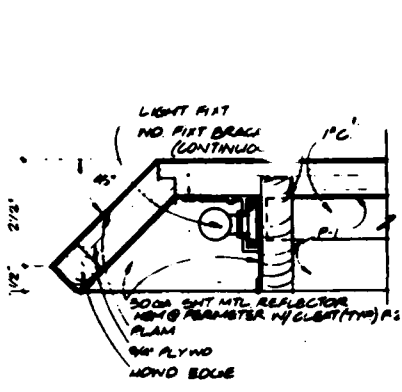

**LIGHT FIXT. DETAIL** (8)  
SCALE: 1/2" = 1'

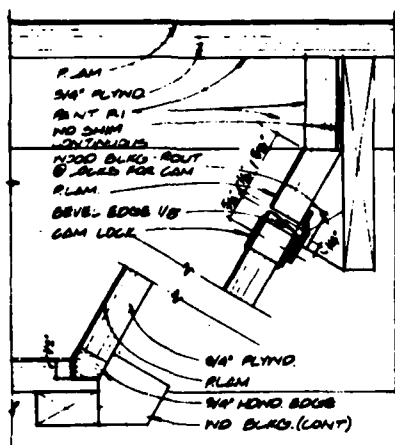

**FRONT PNL. DETAIL** (9)  
SCALE: 1/2" = 1'

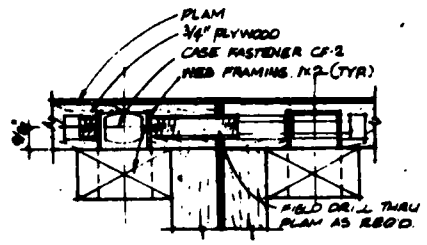

**CASE FASTENER CF-2** (10)  
NO SCALE

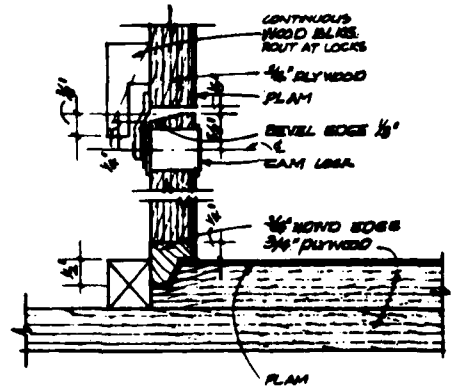

**FRONT PNL. DETAIL** (11)  
NO SCALE

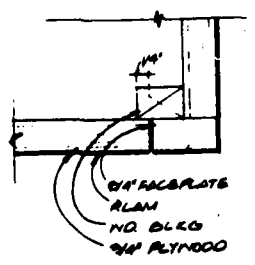

**FRONT PNL. DETAIL** (12)  
SCALE: 1/2" = 1'

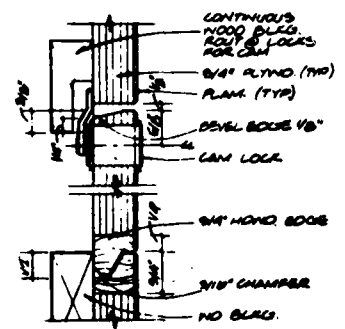

**ACCESS PNL. DETAIL** (13)  
NO SCALE

FIGURE C-11. DETAILS FOR FIGURES C-9 AND C-10

Copy available to DTIC does not permit fully legible reproduction.

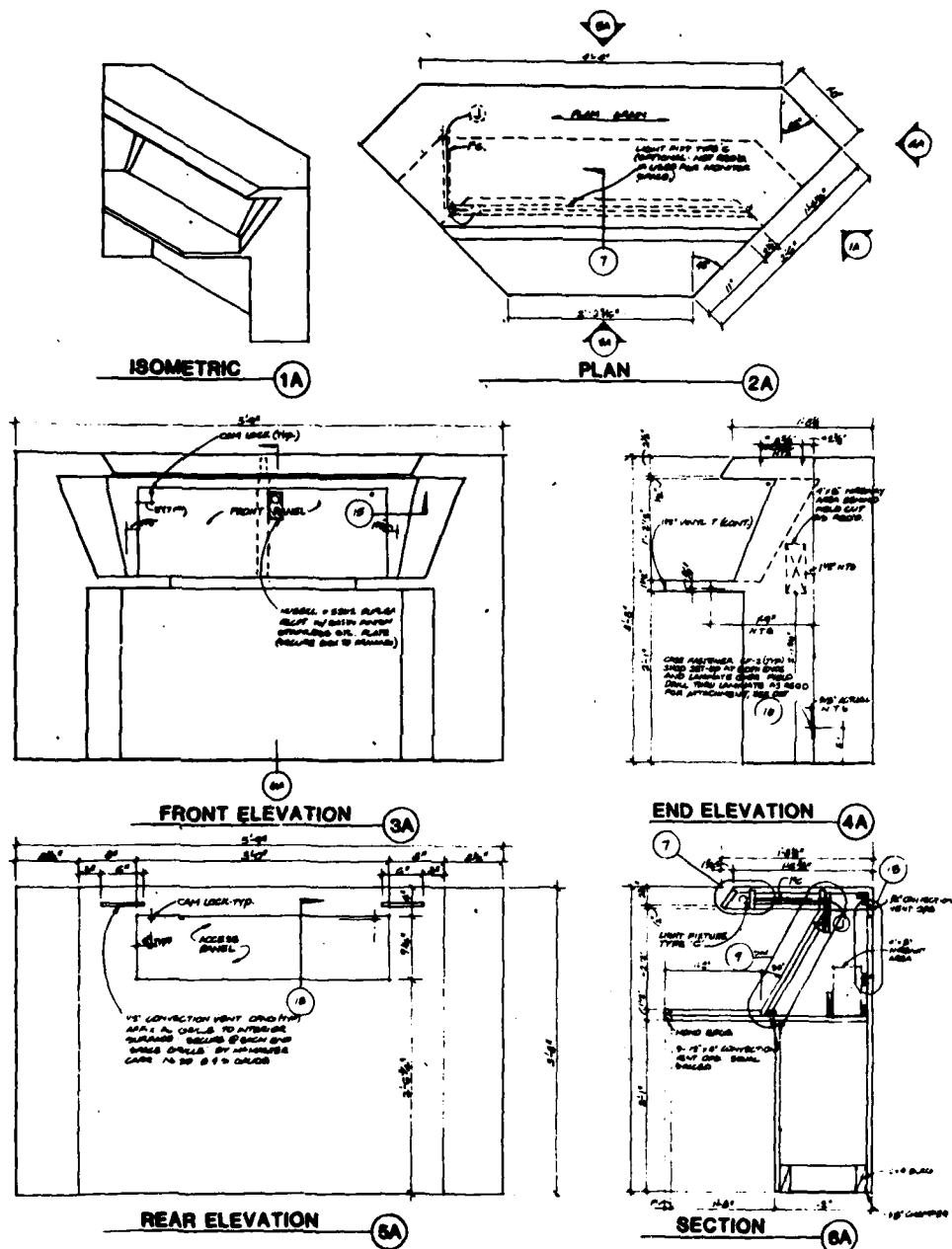
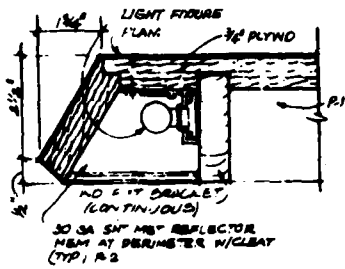

FIGURE C-12. 45° CORNER CONSOLE

Copy available to DTIC does not permit fully legible reproduction





**LIGHT FIXT. DETAIL** (7)  
SCALE: 1/8" = 1"

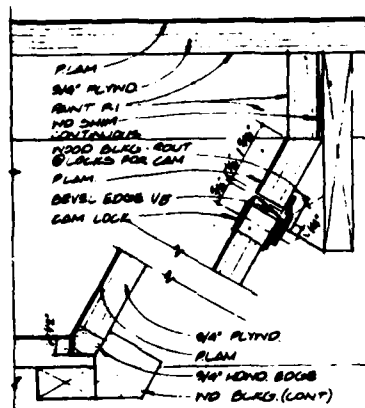

**FRONT PNL. DETAIL** (9)  
SCALE: 1/8" = 1"

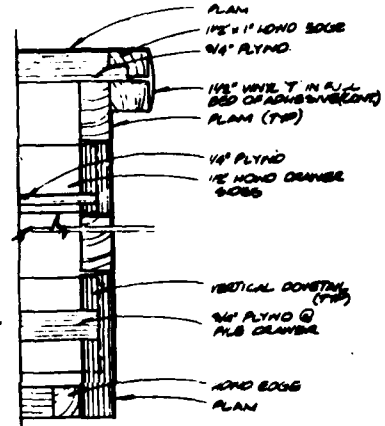

**DRAWER DETAIL** (11)  
SCALE: 1/8" = 1"

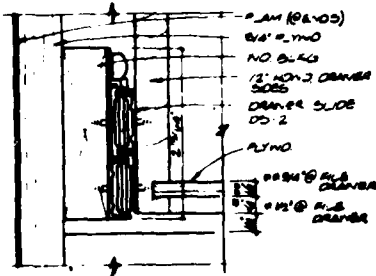

**DRAWER SLIDE DS-2** (8)  
NO SCALE

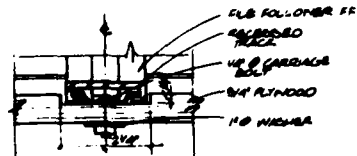

**FILE FOLLOWER DET.** (10)  
SCALE: 1/8" = 1"

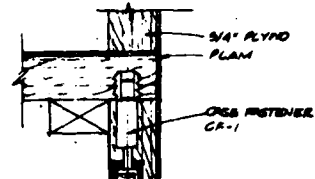

**CASE FASTENER CF-1** (12)  
NO SCALE

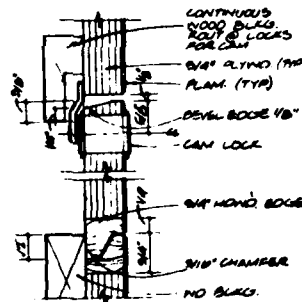

**ACCESS PNL. DETAIL** (13)  
NO SCALE

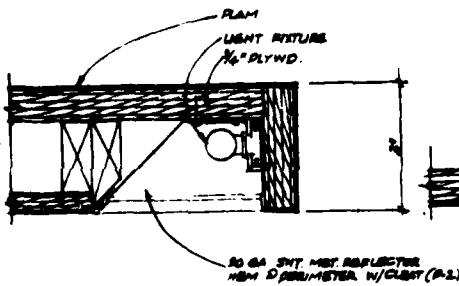

**BOOKCASE LIGHT DET.** (14)  
SCALE: 1/8" = 1"

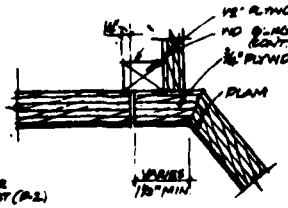

**FRONT PNL. DETAIL** (15)  
SCALE: 1/8" = 1"

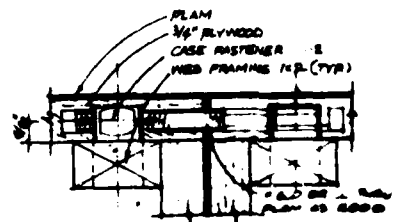

**CASE FASTENER CF-2** (16)  
NO SCALE

FIGURE C-14. DETAILS FOR FIGURES C-12 AND C-13

COPY  
FOR THE...  
...  
...