

AD-A118 912

MATERIALS RESEARCH LABS ASCOT VALE (AUSTRALIA)
A LOW COST, SIMPLE, PORTABLE INSTRUMENT FOR THE MEASUREMENT OF --ETC(U)
MAY 82 F MARSON

F/6 14/2

UNCLASSIFIED

NRL-R-857

NL

10/1
DATE
10-82

END
DATE
FILMED
10-82
DTIC

MRL-R-857

AR-003-038



AD A118912

**DEPARTMENT OF DEFENCE
DEFENCE SCIENCE AND TECHNOLOGY ORGANISATION
MATERIALS RESEARCH LABORATORIES**

MELBOURNE, VICTORIA

REPORT

MRL-R-857

A LOW COST, SIMPLE, PORTABLE INSTRUMENT FOR THE MEASUREMENT
OF INFRA-RED REFLECTANCE OF PAINTS

F. Marson

Approved for Public Release

**DTIC
ELECTE
SEP 7 1982**

B



© COMMONWEALTH OF AUSTRALIA 1982

MAY, 1982

DTIC FILE COPY

00 009

DEPARTMENT OF DEFENCE
MATERIALS RESEARCH LABORATORIES

REPORT

MRL-R-857

A LOW COST, SIMPLE, PORTABLE INSTRUMENT FOR THE MEASUREMENT
OF INFRA-RED REFLECTANCE OF PAINTS

F. Marson

DTIC
ELECTE
SEP 7 1982
S D
B

ABSTRACT

The construction and design of a low cost, simple, portable infra-red reflectometer which can be used to estimate the reflectance of paint films in the 800 nm region is described. The infra-red reflectances of a range of lustreless, semigloss and gloss olive drab camouflage paints determined using this instrument are compared to those obtained using modified commercial equipment and to the reflectances measured at 800 nm using a 'Cary' model 17 spectrophotometer. The new reflectometer was shown to be superior to the modified commercial instrument currently specified in Australian government paint specifications and to be capable of estimating the reflectance of olive drab paints to within about one per cent of the 'Cary' derived reflectance values.

The reflectance values obtained for a range of 24 experimental coatings made with pigments of varying absorption in the infra-red region are used to illustrate the effect of the instrument's spectral response and the necessity of establishing a reliable working standard.

Approved for Public Release

© COMMONWEALTH OF AUSTRALIA 1982

POSTAL ADDRESS: Chief Superintendent, Materials Research Laboratories
P.O. Box 50, Ascot Vale, Victoria 3032, Australia

DOCUMENT CONTROL DATA SHEET

REPORT NO.	AR NO.	REPORT SECURITY CLASSIFICATION
MRL-R-857	AR-003-038	UNCLASSIFIED

TITLE
A LOW COST, SIMPLE, PORTABLE INSTRUMENT FOR THE MEASUREMENT OF
INFRA-RED REFLECTANCE OF PAINTS

AUTHOR(S)	CORPORATE AUTHOR
F. Marson	Materials Research Laboratories P.O. Box 50, Ascot Vale, Victoria 3032

REPORT DATE	TASK NO.	SPONSOR
May, 1982	DST 77/041	DSTO

CLASSIFICATION/LIMITATION REVIEW DATE	CLASSIFICATION/RELEASE AUTHORITY
	Superintendent, MRL Organic Chemistry Division

SECONDARY DISTRIBUTION

Approved for Public Release

ANNOUNCEMENT

Announcement of this report is unlimited

KEYWORDS

Paints	Infrared optical materials
Reflectometers	Portable equipment
Reflectance	

COSATI GROUPS 11030

ABSTRACT

The construction and design of a low cost, simple, portable infra-red reflectometer which can be used to estimate the reflectance of paint films in the 800 nm region is described. The infra-red reflectances of a range of lustreless, semigloss and gloss olive drab camouflage paints determined using this instrument are compared to those obtained using modified commercial equipment and to the reflectances measured at 800 nm using a 'Cary' model 17 spectrophotometer. The new reflectometer was shown to be superior to the modified commercial instrument currently specified in Australian government paint specifications and to be capable of estimating the reflectance of olive drab paints to within about one per cent of the 'Cary' derived reflectance values.

The reflectance values obtained for a range of 24 experimental coatings made with pigments of varying absorption in the infra-red region are used to illustrate the effect of the instrument's spectral response and the necessity of establishing a reliable working standard.

C O N T E N T S

	<u>Page No.</u>
1. INTRODUCTION	1
2. EXPERIMENTAL DETAILS	2
2.1 Apparatus	2
2.2 Calibration of Reflectometer and Working Standard	4
2.3 Comparison of Reflectometers	5
3. DISCUSSION OF RESULTS	6
4. CONCLUSIONS	7
5. ACKNOWLEDGEMENTS	8
6. REFERENCES	8

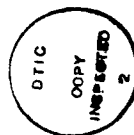

Accession For	
NTIS GRA&I	<input checked="" type="checkbox"/>
DTIC TAB	<input type="checkbox"/>
Unannounced	<input type="checkbox"/>
Justification	
By	
Distribution/	
Availability Codes	
Avail and/or	
Dist	Special
A	

A LOW COST, SIMPLE, PORTABLE INSTRUMENT FOR
THE MEASUREMENT OF INFRA-RED REFLECTANCE OF PAINTS

1. INTRODUCTION

There is a continuing need to measure not only the colour and gloss of camouflage paints but also their reflectance in the near infra-red region. At present, Australian government specifications [1,2,3] for lustreless, semigloss and gloss olive drab camouflage paints require that the reflectance of the paint film at 800 nm shall lie between 34 and 50 per cent.

To measure this reflectance accurately requires a double beam reflectance spectrophotometer, such as the 'Cary' spectrophotometer specified in the above references. These instruments are expensive; their cost precluding their general use by the paint industry and the armed services. Consequently in the late 1960's MRL developed simple and inexpensive modifications [4] to existing commercial paint testing equipment to enable the estimation of infra-red reflectance at 800 nm. The method developed utilising these modified instruments is sufficiently accurate to be used in the check testing of batches and is recommended for this use in Australian government paint specifications. It is also accurate enough to be used by manufacturers for much developmental work. Despite their wide use in industry, these instruments suffer from some defects. They employ reflectance heads fitted with selenium photocells as detectors whose output is measured on a taut suspension mirror type galvanometer. This system is slow to stabilise, subject to drift and because it is not very robust, again essentially non-portable. If these ageing instruments were to be replaced, the major factor would be cost, as the Australian market for camouflage paints is reasonably small. Hence it was decided to examine the feasibility of developing a simple and hence a cheap instrument which was fully portable, robust and suitable for field use as well as check testing and developmental purposes.

The reflectometer which was developed is described and its performance compared to that of a modified 'EEL' reflectance unit, using a 'Cary' spectrophotometer as a reference instrument. In this report the

following definitions apply:

1. 'Cary' spectrophotometer refers to a model 17 'Cary' double beam spectrophotometer fitted with a model 1711 integrating sphere with both phototube and lead sulphide detectors. The illumination employed was monochromatic.
2. 'EEL' reflectometer refers to the MRL modified commercial instrument currently recommended in GPC specifications [1,2,3].
3. Prototype instrument or reflectometer refers to the instrument developed at MRL which is described below.

2. EXPERIMENTAL DETAILS

2.1 Apparatus

The ideal filter based reflectometer would be one using narrow band filters peaking at 800 nm [4]. The initial cost of each narrow band filter is about \$200 to which must be added the cost of relatively complex detection circuitry required because of the very low level of the reflected energy available compared to broad band filters. Consequently, it was decided to use Wratten photographic filters, which were cheap, readily available and had performed satisfactorily for a number of years in the 'EEL' reflectometer. None of the available filters is ideal and the 88A was chosen because it was likely to give a spectral response for the system as a whole which was close to 800 nm, as well as passing a reasonable amount of energy. The next best was the 87 filter which when used in the same configuration would have reduced the available energy by about 70 per cent.

Reflectometers usually employ a light beam incident at 45° to the surface and a photodetector at 90° to the surface, or use illumination normal to the surface and detector/s situated at 45° to the surface. In order to minimise the effects of surface irregularities and texture it was decided to employ the second geometry and to use several detectors, spaced at equal intervals. The source selected was a 6.5 V single filament bulb. To improve long term stability, and to bias the spectral output towards the infra-red end of the spectrum, the bulb was run at 5 V dc. At this voltage the measured filament temperature is just under 2000°C. Cadmium sulphide light dependent resistors (LDRs) were finally selected as the detectors mainly because of their low cost and ready availability. They also had the advantage of reducing the complexity of the electronics required for the detector circuit. Early prototypes using phototransistors employed separate high and low reflectance level adjustments and required amplification of the detector output.

Figure 1 shows the main features of the final prototype. The external case is a commercially available diecast aluminium instrument case (188 mm long, 120 mm wide and 78 mm high). The reflectance 'head' built into one end of this case is constructed of light gauge aluminium sheet and consists of a truncated four sided 45° pyramidal light tight box with a viewing aperture centrally located in its base. The viewing aperture consists of a 25 mm square optical glass window (a section of microscope slide would suffice) fixed flush with the external surface using epoxy resin adhesive. The detectors are mounted symmetrically on each face of the pyramid normal to the 45° reflection path. The inside of the reflectance head is painted matt black to reduce unwanted reflections.

The bulb is held in a commercial lamp socket; up, down and limited sideways adjustment being provided by the use of slots in the external case. Fortunately, no forward or backward adjustment is required using the particular bulb and socket selected. The bulb filament can be positioned with the range of adjustment available so that the output is centred on the 25 mm square glass window. This ensures maximum output, minimum stray light and a symmetrical relationship of source to the detectors. Two Wratten 88A filters are mounted between glass discs using nitrocellulose cement and attached to the apex of the pyramid using the same cement. The aperture is restricted to 7.5 mm in diameter by a washer on the inner surface, so that in conjunction with the shielded lamp globe (whose aperture is the same, 7.5 mm) the irradiated surface of the specimen is a circle 20 mm in diameter. For field use, where the surfaces to be measured are not necessarily flat and high ambient light conditions may be encountered, it is intended to incorporate one of the filters in the external aperture to reduce the effect of stray light.

A 50 microamp taut band meter is mounted on the top of the instrument case, at the opposite end to the reflectometer head. The ten turn potentiometer used to set the meter for the high reflectance level is mounted on the side of the instrument case to reduce temperature variations caused by the light source. The main power supply constructed on 'Veroboard' is mounted on the meter terminals, a finned heat sink being used to cool the bridge rectifier. The voltage regulator is mounted directly onto the instrument case which acts as a heat sink. The case itself is ventilated, care being taken to keep stray light to a minimum. None of the dimensions or constructional details appear critical except for the alignment of the source and detectors and the need to ensure that unwanted stray light is excluded from the reflectometer head.

Figure 2 shows the circuit diagram of the electronics, provision being made for both mains and 12 or 24 volt battery operation. Either 9 V ac or 12 V dc can be supplied directly to the bridge rectifier whose output under load is about 11 V dc. As a stable supply is required of approximately 1.5 A at 5 V dc, a heavy duty three terminal positive voltage regulator is used (a Fairchild 78H05) which ensures a safety margin in the event of elevated temperature or overvoltage. As this regulator has a maximum recommended input voltage of 20 V, a dropping resistor is required to operate from truck or other heavy vehicle supplies (usually in the range 24 to 27 V).

The detector circuit consists of the LDR array, a single 10 turn potentiometer to set the high level response and a thermistor with bypass to

reduce temperature effects. The value of the bypass resistor was chosen to minimise temperature effects. The thermistor was mounted within the reflectance 'head' as the LDRs appeared the components most susceptible to temperature change. Table 1 lists the main characteristics of the LDRs used. Because of the variation in light resistance values encountered in commercial LDRs, resistance values under moderate light conditions were measured and four LDRs of fairly close match selected (out of six). It is only necessary to get a close match if it is intended to measure highly textured or irregular surfaces. In this circuit configuration the maximum dissipation of a single LDR is less than 1 mW, well within the safe working range even at elevated temperatures. The zero set screw on the meter itself is sufficient to offset the signal generated by stray light and the dark current of the detector circuit.

2.2 Calibration of Reflectometer and Working Standard

Because the spectral response of the instrument is governed by the spectral distribution of the source, the transmission characteristics of the filter, and the response of the detectors, it does not measure reflectance at 800 nm but integrates reflectance over a range of wavelengths close to 800 nm. Figure 3 shows the change in spectral emittance at the measured filament temperature of 2000°C calculated from Plank's formula, the transmission of a Wratten 88A filter [5] and the response characteristics of a cadmium sulphide LDR. The spectral emittance of the tungsten filament doubles from 700 to 900 nm. The filter passes no radiation below 720 nm but at 750 nm transmits nearly 60 per cent of the incident energy, reaching a transmission of 80 per cent at 800 nm. The LDR response is close to its maximum about 700 nm falling fairly uniformly to zero at 900 nm. When these responses are combined, allowing for the double filter incorporated in the instrument, the illustrated theoretical spectral response curve for the instrument is obtained. Thus the reflectometer begins to detect reflected energy at about 730 nm, rises fairly sharply to a peak response at about 770 nm, the response then decreases steadily to nothing at about 890 nm.

Table 2 shows the expected variation in reflectometer response for a uniformly reflecting surface. Sixty one per cent of the total response is below 800 nm and for the ranges 50 nm either side of 800 nm, 54 per cent is below and 32 per cent above. This largely explains why perfect matches with spectrophotometrically determined results at 800 nm are not always obtained and why it could be unwise to use as an upper standard for calibration of the instrument a tile or standard measured spectrophotometrically only at 800 nm. Fortunately most camouflage paints which match the requirements of the current Australian paint specifications, have basically similar pigmentation and consequently their spectral reflectance curves around 800 nm are similar. If these are used to establish primary standards (using a referee spectrophotometer) and the working standard calibrated from them, then the difference between values measured using this and similar reflectometers and referee reflectance spectrophotometers should be small. However if this type of instrument is used to measure the reflectance of surfaces which exhibit sharply changing response curves in the region of 750 to 850 nm then significant errors could occur. This aspect is treated in more detail in the discussion of experimental results.

The method of calibrating the 'EEL' reflectometer uses paint intermediate standards [4]. As the MRL developed instrument was to be compared to the 'EEL' instrument and because of the considerations raised above it was decided to calibrate both instruments using the same paint standards. The standards used were those originally supplied for the calibration of the modified commercial instruments [4]. The procedure adopted to calibrate the prototype reflectometer and working standard was somewhat different from that established for the 'EEL' instrument. The adjustment required for setting zero reflectance is only about one per cent of the full scale deflection, representing the small dark current of the detector circuit and a somewhat smaller signal generated by the stray light within the detector head. The zero was set by siting the aperture over a light tight box lined inside with black velvet and adjusting the meter needle adjustment screw so that the scale read zero when the full scale deflection was approximately correct. Experience with gloss meters had confirmed that such boxes approximated to total absorption. Because of the stability of the meter reading and the limited drift shown by the prototype instrument, zero adjustment was only required occasionally.

The working standard selected was a polished white glass tile calibrated in the following manner. The reflectometer was switched on and allowed to stabilise for about 10 minutes and the scale adjusted to read the reflectance of each of the intermediate standards previously used, the reading obtained when placed on the white tile was then recorded. Table 3 gives the values obtained with the particular working standard selected. The values adopted were 85 per cent for matt surfaces and 87 per cent for glossy ones. The use of a larger number of intermediate standards might increase the accuracy and on a basis of the measurements reported below more suitable values can now be assigned for this particular working standard, when used with Australian olive drab camouflage paints.

2.3 Comparison of Reflectometers

The infra-red reflectance of twelve each of lustreless, semigloss and gloss olive drab camouflage paints (from a number of manufacturers), applied in accordance with Australian standard method 601.1 [6] to colour comparison cards, were measured using a 'Cary' model 17 reflectance spectrophotometer, the 'EEL' instrument described previously [4] and the prototype reflectometer. The measurements were single readings taken in the centre of each test card. The operator using the prototype instrument was not trained in its use and had little practice; he had however several years experience in the use of the 'EEL' reflectometer. The reflectance values and the differences between these and that measured at 800 nm using the 'Cary' spectrophotometer are recorded in Tables 4, 5 and 6.

Table 7 lists the 'Cary' and prototype instrument's reflectance measurements on some 24 experimental coatings prepared to evaluate a range of pigments for potential use in camouflage paints. A single lustreless olive drab paint was also included in this series in which complete visual and infra-red spectra were recorded (for other purposes) using the spectrophotometer.

3. DISCUSSION OF RESULTS

Tables 4, 5 and 6 compare the two reflectometers against the more accurate referee spectrophotometer for a range of olive drab camouflage paints. The prototype instrument apparently has an average error approximately half that of the 'EEL' reflectometer, a similar ratio applies to the maximum recorded errors. On the basis of these results the prototype reflectometer would appear to show a significant improvement in performance. However, the distribution of the errors is not uniform and the two instruments show an overall bias for each group of paints. This bias is a combination of a number of factors including the spectral response of the instrument, linearity of the detector system, the accuracy of determining the working standard/s and the optical geometry of the instrument. If the overall instrumental bias for each group of paints is allowed for, the 'EEL' instrument shows a substantial improvement in its performance in estimating the infra-red reflectance of lustreless paints, the average error being reduced to 0.4 and the maximum error to 0.8 per cent. Allowing for overall bias gives the 'EEL' instrument an average error of 0.7 and a maximum of 2.3 per cent for all 36 paints and the prototype reflectometer an average error of 0.5 and a maximum of 1.3 per cent. Thus if the causes of bias in the 'EEL' instrument could be eliminated, the performance of the prototype instrument might not be quite as good as appears at first sight. The major cause of bias appears to be the difficulty in calibrating the instrument which in turn depends on the establishment of correct values for the working standard/s. Here the prototype instrument shows a major advantage, because of the very low dark current of the detector circuit and of a similarly low stray light within the detector head, only a small adjustment of the meter is required to set the zero reflectance level and once set it rarely requires further adjustment.

The accuracy of setting the upper reflectance standard can be estimated from a regression analysis of the reflectance values obtained spectrophotometrically and using the prototype instrument. Table 8 shows the values predicted by the regression analysis for assumed 'Cary' values of zero, 85 per cent for the lustreless paints and 87 per cent for the semigloss and gloss paints, which were the values adopted for the working standards. From this analysis it appears that the zero setting is appropriate for all three classes of olive drab paints, but that closer agreement with the spectrophotometric values would be obtained if the working standard were set to 85 for lustreless paints, 86.5 for semigloss and 86 per cent for gloss paints. If the values reported in Tables 5 and 6 are adjusted to those which would have been obtained using these new settings for the working standard, the average error would be reduced to 0.7 per cent for semigloss and 0.4 per cent for the gloss paints. The overall bias would also be virtually eliminated. However it is obvious from the spectral response of the instrument that this level of agreement could only be expected where the range of paints to be examined have similar spectral properties. When paints are made with different pigments, many with substantially different spectral properties in the infra-red region, then the errors encountered can be quite large as can be seen from Table 7, where the difference between the reflectance at 800 nm and that measured using the prototype reflectometer is as much as 8 per cent.

The reason for these differences is illustrated in Figure 4 which shows the theoretical spectral response of the reflectometer and the reflectance curves of three paints, numbers 8, 17 and 25 which show substantial differences between 'Cary' and reflectometer values. Figure 4 also shows the reflectance curve for a typical olive drab camouflage paint, number 18. As can be seen all four paints have sharply changing reflectance values in the region where the spectral response of the reflectometer also varies. Paint 18 which is typical of olive drab camouflage paints, has a spectrophotometrically determined reflectance at 800 nm of 39.4 per cent and a reflectance of 40.1 per cent determined using the prototype instrument. From the calculated spectral response of the reflectometer and the 'Cary' reflectance curve it appears that some 60 per cent of the reflectometers response is obtained from wavelengths below 800 nm. Paint 17 which has a low reflectance compared to the olive drab paint below 800 nm would consequently be expected to have a reflectometer determined reflectance lower than the spectrophotometrically determined reflectance at 800 nm. Paints 8 and 25 which have higher reflectances in the region of the reflectometers maximum response would be expected to show a higher reflectance when measured by the prototype instrument. Table 7 confirms this. However the difference between the two instruments is somewhat larger than would be expected from the predicted reflectometer response, indicating that the reflectometer has a somewhat greater response at lower wavelengths or a sharper cut off at higher wavelengths than predicted.

It is probable that other instruments based on this design would show variations in spectral response related to the source, filters and particular LDRs used. However, as with the instrument described above, calibration of the working standard using paints with similar pigmentation should reduce errors in estimating reflectance to a low level.

4. CONCLUSIONS

The prototype reflectometer is a simple inexpensive instrument which can be used to measure the infra-red reflectance of camouflage paints. It is robust and portable and consequently is well suited for field use.

The accuracy of measurement for olive drab paints appears adequate for most specification, development and testing purposes. For the 36 olive drab camouflage paints studied, the average error was about 0.6 and the maximum 1.2 per cent when the working standard was established using the paints originally used to set the high and low reflectance standards of the modified commercial instrument currently specified. If the working standard is calibrated for each of the three groups of olive drab paints from a regression analysis of the measurements carried out then the average error for these paints would have been reduced to 0.4 per cent which is approaching the readability of the instrument and the accuracy of individual measurements taken with the Cary spectrophotometer.

When used to estimate the reflectance of paints with widely varying infra-red properties the reflectometer is shown to be less accurate where the spectral reflectance of the paint differs markedly in the region of the instruments response from the spectral reflectance of the paints used to calibrate the working standard.

5. ACKNOWLEDGEMENTS

The author wishes to thank R.J. Hancox for the infra-red measurements carried out on the 'Cary' spectrophotometer, J. Gagliardi who assisted with the preparation of the experimental camouflage paints and P.J. Shanahan who assisted with the reflectometer measurements.

6. REFERENCES

1. G.P.C. Specification GPC-E-7, 1 May 75, Commonwealth of Australia.
2. G.P.C. Specification GPC-E-6, 1 May 75, Commonwealth of Australia.
3. G.P.C. Specification GPC-E-8, 1 May 75, Commonwealth of Australia.
4. Marson, F. (1968). A Simple Method for the Measurement of Infra-Red Reflectance of Paints. Technical Note 110. Defence Standards Laboratories.
5. Handbook of Chemistry and Physics, CRC Press, Florida, 1980, E-387.
6. Method 601.1, AS 1580, May 1975.

T A B L E 1

CHARACTERISTICS OF 'PHILLIPS' ELCOMA TYPE LIGHT
DEPENDENT RESISTORS

Dark Resistance	> 10 M Ω
Light Resistance (at 1000 lux)	70 Ω to 300 Ω
Recovery Rate	> 200 k Ω /s
Maximum Dissipation at 40°C	0.1 W
Temperature Range	-30°C to +60°C

T A B L E 2

EXPECTED VARIATION IN REFLECTOMETER RESPONSE WITH WAVELENGTH
FOR A UNIFORM REFLECTING SURFACE

Wavelength Range nm	710- 730	730- 750	750- 770	770- 790	790- 810	810- 830	830- 850	850- 870	870- 890	890- 910
Per Cent of Total Response	0	6.7	21.8	23.0	18.9	13.8	9.1	5.1	1.6	0

T A B L E 3

CALIBRATION OF WORKING STANDARD

Olive Drab Camouflage Paints	Per Cent Reflectance at 800 nm	Meter Reading Working Standard	Average Reading Working Standard
MATT Low Reflectance	24.3	84.5, 84.2, 84.0	84.3 (85.4)
High Reflectance	50.2	86.4, 87.0, 86.5	86.6
GLOSS Low Reflectance	22.9	86.7, 86.5, 87.0	86.7 (87.1)
High Reflectance	46.1	87.4, 88.0, 87.0	87.5

T A B L E 4

REFLECTANCE MEASUREMENTS ON LUSTRELESS OLIVE DRAB

CAMOUFLAGE PAINTS

Sample Number	Reflectance at 800 nm Per Cent Cary 17	Reflectance Per Cent 'EEL' Reflectometer	Difference Per Cent	Reflectance Per Cent Prototype Reflectometer	Difference Per Cent
1	39.9	38.5	-1.4	40.8	+0.9
2	27.9	27.6	-0.3	28.0	+0.1
3	35.4	33.6	-1.8	35.2	-0.2
4	37.1	36.0	-1.1	37.0	-0.1
5	34.9	34.6	-0.3	35.0	+0.1
6	41.6	40.3	-1.3	41.5	-0.1
7	39.1	38.0	-1.1	39.0	-0.1
8	38.2	36.7	-1.5	38.4	+0.2
9	42.1	41.0	-1.1	41.8	-0.3
10	40.8	39.0	-1.8	41.0	+0.2
11	42.3	41.2	-1.1	42.0	-0.3
12	33.6	33.1	-0.5	33.5	-0.1
Error					
Average			1.1		0.2
Maximum			1.8		0.9
Overall Bias			-1.1		0

T A B L E 5

REFLECTANCE MEASUREMENTS ON SEMIGLOSS OLIVE DRAB

CAMOUFLAGE PAINTS

Sample Number	Reflectance at 800 nm Per Cent Cary 17	Reflectance Per Cent 'EEL' Reflectometer	Difference Per Cent	Reflectance Per Cent Prototype Reflectometer	Difference Per Cent
13	40.8	40.0	-0.8	40.9	+0.1
14	39.8	38.0	-1.8	40.7	+0.9
15	21.3	21.2	-0.1	20.9	-0.4
16	30.0	31.4	+1.4	31.1	+1.1
17	43.7	42.5	-0.8	43.2	-0.5
18	44.2	42.0	-2.2	43.0	-1.2
19	43.9	42.4	-1.5	43.0	-0.9
20	45.3	45.0	-0.3	45.2	-0.1
21	20.9	22.9	+2.0	19.7	-1.2
22	36.0	36.5	+0.5	37.1	+1.1
23	45.3	46.1	+0.8	46.3	+1.0
24	41.9	41.5	+0.4	42.8	+0.9
Error					
Average			1.1		0.8
Maximum			2.2		1.2
Overall Bias			-0.3		+0.1

T A B L E 6

REFLECTANCE MEASUREMENTS ON GLOSS OLIVE DRAB

CAMOUFLAGE PAINTS

Sample Number	Reflectance at 800 nm Per Cent Cary 17	Reflectance Per Cent 'EEL' Reflectometer	Difference Per Cent	Reflectance Per Cent Prototype Reflectometer	Difference Per Cent
25	42.2	43.0	+0.8	43.0	+0.8
26	33.5	32.5	-1.0	34.6	+1.1
27	42.9	42.0	-0.9	43.5	+0.6
29	41.8	42.5	+0.7	43.0	+1.2
30	42.5	42.5	0	43.0	+0.5
31	38.4	37.0	-1.4	37.9	-0.5
32	31.5	32.8	+1.3	32.5	+1.0
33	31.4	32.6	+1.2	32.2	+0.8
34	36.4	36.8	+0.2	36.8	+0.4
35	42.2	44.0	+1.8	43.2	+1.0
36	32.8	32.2	-0.6	32.8	0
Error					
Average			1.0		0.7
Maximum			1.8		1.1
Overall Bias			+0.1		+0.5

T A B L E 7

EFFECT OF PIGMENT VARIATION ON REFLECTOMETER PERFORMANCE

System Number	Pigmentation and Additives	Reflectance at 800 nm Per Cent Cary 17	Reflectance Per Cent Prototype Reflectometer	Difference Per Cent
1	Ferrocolour green V11633	33.3	33.4	+0.1
2	S.F. Olive green 97977N	23.6	23.7	+0.1
3	MRL Cobalt zinc (4.5% Co)	20.8	21.3	+0.5
4	MRL Cobalt zinc (2% Co)	35.2	36.7	+1.5
5	S.F. Cobalt green 771	37.8	36.7	-1.1
6	S.F. Cobalt green 772	34.7	34.8	+0.1
7	S.F. Cobalt green 770	38.6	40.6	+2.0
8	Ferrogreen CoTiO ₃	52.4	59.0	+6.6
9	Chromium oxide GX	47.8	46.9	-0.9
10	S.F. 772 + Helio fast black IR	33.1	32.4	-0.7
11	S.F. 767 + Yellow chrome	37.9	43.5	+5.6
12	S.F. 769 + Yellow chrome	35.2	41.6	+6.4
13	Ferrocolour F622 + yellow chrome	41.0	45.4	+4.4
14	F'colour V9420 + Monastral blue	35.3	26.6	-8.7
15	Tipaque NiTiO ₃ + Monastral blue	32.3	27.1	-5.2
16	MRL MIL-P-46168 (NR)	43.4	44.0	+0.6
17	PbCrO ₄ + Monastral blue	31.0	25.1	-5.9
18	EPM Lustreless olive drab	39.4	40.1	+0.7
19	F'colour F622 + Hansa Yellow	44.8	53.2	+8.4
20	F'colour V9420 + S.F. 769	55.1	63.8	+8.7
21	Cobalt zinc (2% Co) + Uvitex	34.7	35.8	+1.1
22	Cobalt zinc (2% Co) + Liq. crystal	34.3	36.7	+2.4
23	Cobalt zinc (2% Co) + dissolved Uvitex	34.2	35.8	+1.6
24	Cobalt zinc (2% Co) + fluorescent ZnS	34.2	35.8	+1.6
25	Drakenfield green	52.1	58.0	+5.9

T A B L E 8

ACCURACY OF LOW AND HIGH STANDARDS FROM

REGRESSION ANALYSIS

For Spectrophotometric Reading Per Cent	Predicted Reflectometer Reading - Per Cent		
	Lustreless	Semigloss	Gloss
0	0.02	-0.18	0.14
85	85.02	-	-
87	-	87.42	87.95
Proposed New Settings for Standards			
0	0	0	0
High Reflectance	85	86.5	86.0

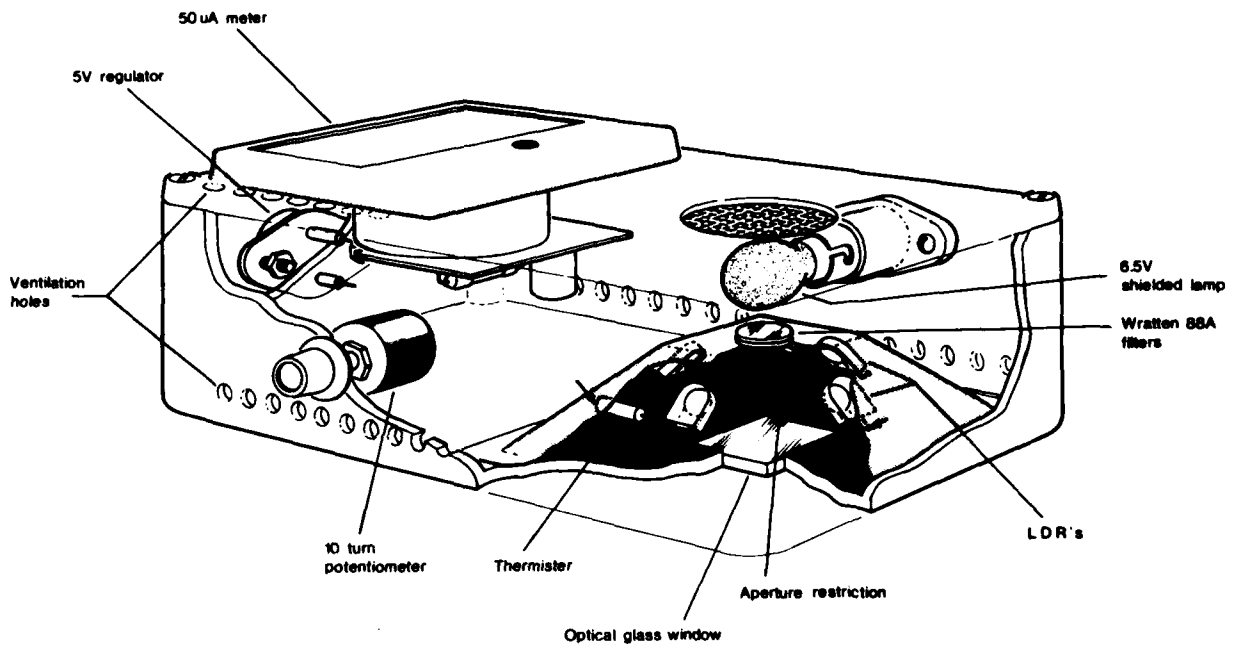

FIG. 1 Diagramatic Representation of Prototype Reflectometer

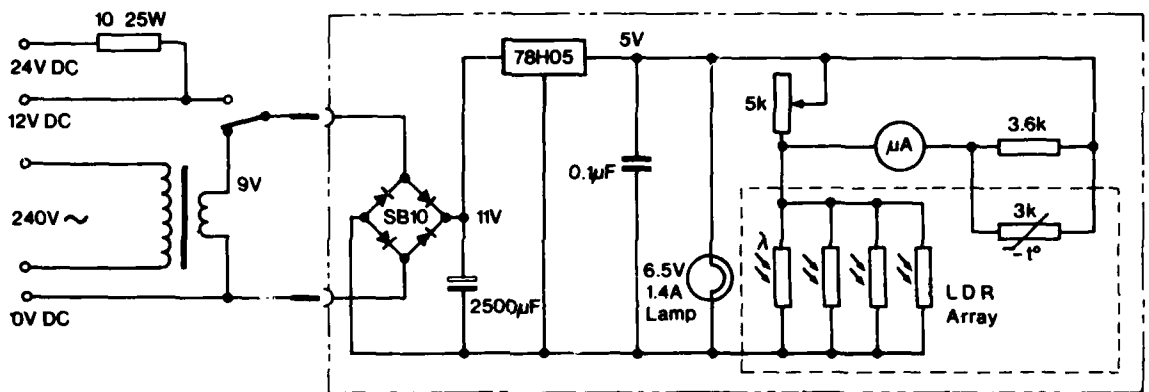

FIG. 2 Circuit Diagram of Infra-Red Reflectometer

- Response for LDR with two Wratten 88A filters and 2000°C tungsten filament source
- - - Spectral response 2000°C tungsten filament
- Spectral response LDR
- - - Transmission single Wratten 88A filter

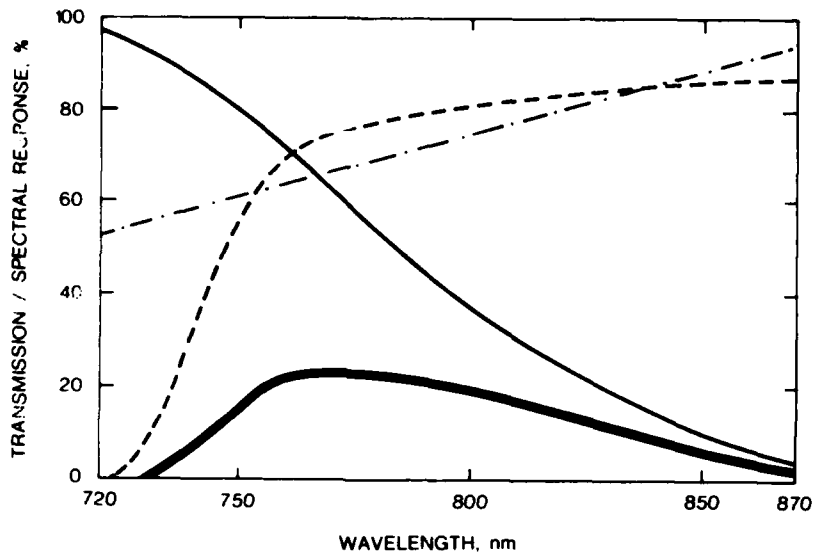

FIG. 3 Variation in Transmission, Emission and Response with Wavelength for Wratten 88A Filter, Tungsten Filament at 2000°C and Elcoma Type LDR and these combined to give the calculated spectral response of the prototype reflectometer

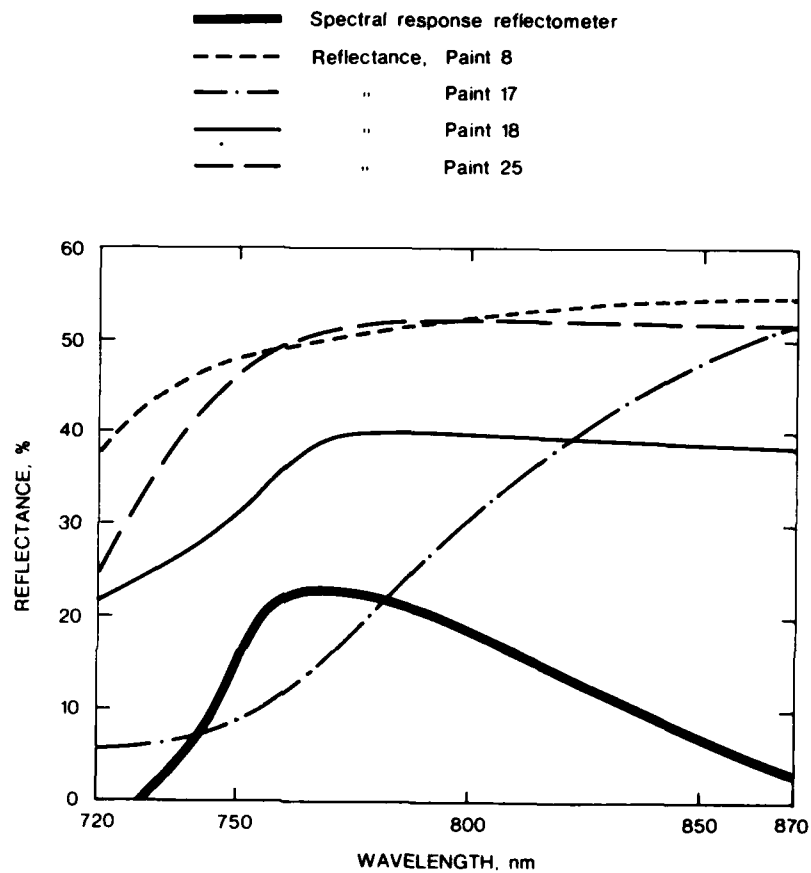

FIG. 4 Reflectance of Paints over the Wavelength Range 720 to 870 nm Compared to the Calculated Spectral Response of the Prototype Reflectometer

(MRL-R-857)

DISTRIBUTION LIST

MATERIALS RESEARCH LABORATORIES

Chief Superintendent
Superintendent, Organic Chemistry Division
Library (2 copies)
Mr. F. Marson

DEPARTMENT OF DEFENCE

Chief Defence Scientist/Deputy Chief Defence Scientist/
Controller, Projects and Analytical Studies/
Superintendent, Science and Technology Programme (1 copy)
Army Scientific Adviser
Air Force Scientific Adviser
Navy Scientific Adviser
Librarian (Through Officer-in-Charge), Materials Testing
Laboratories, Alexandria, NSW
Senior Librarian, Aeronautical Research Laboratories
Senior Librarian, Defence Research Centre, Salisbury, SA
Officer-in-Charge, Document Exchange Centre (17 copies)
Technical Reports Centre, Defence Central Library
Central Office, Directorate of Quality Assurance - Air Force
Deputy Director Scientific and Technical Intelligence, Joint
Intelligence Organisation
Librarian, Bridges Library
Librarian, Engineering Development Establishment
Defence Science Representative, (Summary Sheets Only)
Australian High Commission, London
Counsellor Defence Science, Washington, D.C. (Summary Sheets Only)

DEPARTMENT OF INDUSTRY & COMMERCE

NASA Canberra Office, Woden, ACT
Head of Staff, British Defence Research & Supply Staff (Aust.)

OTHER FEDERAL AND STATE DEPARTMENTS AND INSTRUMENTALITIES

The Chief Librarian, Central Library, CSIRO
Library, Australian Atomic Energy Commission Research Establishment

MISCELLANEOUS - AUSTRALIA

Librarian, State Library of NSW, Sydney NSW

(MRL-R-857)

DISTRIBUTION LIST
(Continued)

MISCELLANEOUS - OVERSEAS

Library - Exchange Desk, National Bureau of Standards, USA
UK/USA/CAN/NZ ABCA Armies Standardisation Representative (4 copies)
The Director, Defence Scientific Information & Documentation
Centre, India
Military, Naval and Air Adviser, High Commission of India,
Canberra
Director, Defence Research Centre, Kuala Lumpur, Malaysia
Exchange Section, British Library, U.K.
Periodicals Recording Section, Science Reference Library,
British Library, U.K.
Library, Chemical Abstracts Service
INSPEC: Acquisition Section, Institution of Electrical
Engineers, U.K.
Engineering Societies Library, U.S.A.
Aeromedical Library, Brooks Air Force Base, Texas, U.S.A.

MEI
-8