

AD-A118 937 WASHINGTON UNIV SEATTLE DEPT OF ATMOSPHERIC SCIENCES F/8 9/2
DEVELOPMENT OF A MICROCOMPUTER PROGRAM FOR DATA COLLECTION AND --ETC(U)
FEB 80 M J BRENOLE, K B KATSAROS N00014-75-C-0502
UNCLASSIFIED CONTRID-634 NL

1 of 1
1584



END
DATE
FILMED
10 87
DTIC

AD A118937

12

TECHNICAL REPORT OFFICE OF NAVAL RESEARCH
CONTRACT N00014-75-C-0502 MOD P00015

DEVELOPMENT OF A MICROCOMPUTER PROGRAM FOR DATA
COLLECTION AND PROCESSING IN FIELD EXPERIMENTS

MICHAEL J. BRENGLE⁺
KRISTINA B. KATSAROS

DEPARTMENT OF ATMOSPHERIC SCIENCES
UNIVERSITY OF WASHINGTON
SEATTLE, WASHINGTON 98195

FEBRUARY 1980

REPRODUCTION IN WHOLE OR IN PART IS PERMITTED
FOR ANY PURPOSE OF THE UNITED STATES GOVERNMENT

ATMOSPHERIC SCIENCES CONTRIBUTION NUMBER 634

DTIC
SELECTE
SEP 07 1982
E

DISTRIBUTION UNLIMITED

82 09 07 219

DTIC FILE COPY

REPORT DOCUMENTATION PAGE		READ INSTRUCTIONS BEFORE COMPLETING FORM
1. REPORT NUMBER Atmospheric Sciences #634	2. GOVT ACCESSION NO. AD-A118937	3. RECIPIENT'S CATALOG NUMBER
4. TITLE (and Subtitle) Development of a microcomputer program for data collection and processing in field experiments	5. TYPE OF REPORT & PERIOD COVERED Technical Report	
	6. PERFORMING ORG. REPORT NUMBER Atmospheric Sciences #634	
7. AUTHOR(s) Brengele, M. J. and K. B. Katsaros	8. CONTRACT OR GRANT NUMBER(s) N00014-75-C-0502	
9. PERFORMING ORGANIZATION NAME AND ADDRESS Department of Atmospheric Sciences AK-40 University of Washington Seattle, WA 98195	10. PROGRAM ELEMENT, PROJECT, TASK AREA & WORK UNIT NUMBERS NR 083 012	
11. CONTROLLING OFFICE NAME AND ADDRESS Office of Naval Research NORDA Code 410/ONR Code 480 NSTL Station, Bay St. Louis, MS 39529	12. REPORT DATE ██████████	
	13. NUMBER OF PAGES 9	
14. MONITORING AGENCY NAME & ADDRESS (if different from Controlling Office)	15. SECURITY CLASS. (of this report) UNCLASSIFIED	
	15a. DECLASSIFICATION/DOWNGRADING SCHEDULE	
16. DISTRIBUTION STATEMENT (of this Report) Approved for Public Release - Distribution Unlimited		
17. DISTRIBUTION STATEMENT (of the abstract entered in Block 20, if different from Report)		
18. SUPPLEMENTARY NOTES		
19. KEY WORDS (Continue on reverse side if necessary and identify by block number) Atmospheric surface layer measurements Data logger Microcomputer		
20. ABSTRACT (Continue on reverse side if necessary and identify by block number) The Atmospheric Sciences Department at the University of Washington has established an experimental site on Lake Washington, where turbulent fluxes, wave height, and other air-sea interaction related measurements are obtained. The present configuration consists of a mast, positioned 30 m from shore, on which a variety of meteorological instruments are mounted. The instrument analog signals are sent back to shore via lines and are digitized and recorded on audio tape with a frequency shift keying system. The digital values are also input (16 bit parallel to 2 ports) to an IMSAI 8080 microcomputer which		

20. ABSTRACT (cont.)

computes averages and cross products and periodically prints a report and records results on a floppy disk. The averaging time is variable from 30 seconds to 35 minutes. The use of real time processing of the data is a valuable time saver. This microcomputer system and its software development is described in this report.

TECHNICAL REPORT OFFICE OF NAVAL RESEARCH
CONTRACT N00014-75-C-0502 MOD P00015

DEVELOPMENT OF A MICROCOMPUTER PROGRAM FOR DATA
COLLECTION AND PROCESSING IN FIELD EXPERIMENTS

MICHAEL J. BRENGLE⁺
KRISTINA B. KATSAROS

DEPARTMENT OF ATMOSPHERIC SCIENCES
UNIVERSITY OF WASHINGTON
SEATTLE, WASHINGTON 98195

FEBRUARY 1980

REPRODUCTION IN WHOLE OR IN PART IS PERMITTED
FOR ANY PURPOSE OF THE UNITED STATES GOVERNMENT

ATMOSPHERIC SCIENCES CONTRIBUTION NUMBER 634

DISTRIBUTION UNLIMITED

Accession For	
NTIS GRA&I	<input checked="" type="checkbox"/>
DTIC TAB	<input type="checkbox"/>
Unannounced	<input type="checkbox"/>
Justification	
By _____	
Distribution/	
Availability Codes	
Dist	Availability, or Special
A	



DEVELOPMENT OF A MICROCOMPUTER PROGRAM FOR DATA
COLLECTION AND PROCESSING IN FIELD EXPERIMENTS

Michael J. Brengle[†]

Kristina B. Katsaros

Department of Atmospheric Sciences
University of Washington
Seattle, Washington 98195

FEBRUARY 1980

REPRODUCTION IN WHOLE OR IN PART IS PERMITTED
FOR ANY PURPOSE OF THE UNITED STATES GOVERNMENT

Atmospheric Sciences Contribution Number 634

[†]Present affiliation: Siemens Corporation
5500 Broken Sound Blvd., Boca Raton, Florida 33431

Foreward

This description of the development of a microcomputer system for the handling of turbulence signals collected at the rate of 400 sec^{-1} has been produced in order to share the experience gained in the process and to provide a record. The components were bought in 1976 and the system has been in use since 1977. The choice of an IMSAI-8080 microprocessor for the central unit was made because for the funds available (about \$5,000) the commercial microcomputers available at that time were not fast enough.

Kristina B. Katsaros
Principal Investigator
ONR Contract N00014-75-C-0502

Abstract

The Atmospheric Sciences Department at the University of Washington has established an experimental site on Lake Washington, where turbulent fluxes, wave height, and other air-sea interaction related measurements are obtained. The present configuration consists of a mast, positioned 30 m from shore, on which a variety of meteorological instruments are mounted. The instrument analog signals are sent back to shore via lines and are digitized and recorded on audio tape with a frequency shift keying system. The digital values are also input (16 bit parallel to 2 ports) to an IMSAI-8080 Microcomputer which computes averages and cross products and periodically prints a report and records results on a floppy disk. The averaging time is variable from 30 seconds to 35 minutes. The use of real time processing of the data is a valuable time saver. This microcomputer system and its software development is described in this report.

Introduction

Studies of the turbulent fluxes in the atmospheric surface layer have until recently meant cumbersome, tedious and time consuming data retrieval and analysis procedures. In order to calculate the turbulent fluxes of momentum, sensible heat and water vapor directly, employing the eddy correlation technique (Busch, 1973), high frequency fluctuations of horizontal and vertical velocity, temperature and humidity must be collected. The time response of the transducers must be fast enough to sample all the flux carrying eddies. Typically, one samples at 10 to 20 Hz. The momentum flux is proportional to the average of the covariance between horizontal (u') and vertical (w') wind velocity fluctuations, $\overline{u'w'}$. Similarly, for sensible heat flux we calculate $\overline{T'w'}$ and for vapor flux $\overline{q'w'}$, where T is temperature and q specific humidity (Busch, 1973).

The procedure for obtaining these values of integrated covariances has been to digitize the analog voltage signals from the transducers with a frequency shift keying (FSK) unit at a total sampling rate of 429 samples/sec and to record the digitized data in analog form on a 1/4" magnetic tape. These tapes are later played back and converted to 1/2" 7-track binary tape by a Raytheon 707 minicomputer, which requires 1 hour of processing time for 1 hour of data. Then the relevant cross products, $\overline{u'w'}$, $\overline{T'w'}$, $\overline{q'w'}$, can be found and the analysis proceeds on the same minicomputer or on larger computers. This was at one time a sophisticated procedure and has functioned quite well (Stage, 1976; Khalsa, 1978).

However, as the techniques of analysis became standardized, it was recognized that many of these steps are repetitive and unnecessary.

The high frequency data is often only needed for quality checks. It is, therefore, usually sufficient to obtain integrated cross correlations over some specified time interval. This was done in the past occasionally when the whole minicomputer with peripherals was taken to the field (an expensive procedure which also disrupts other analysis work). In-field processing of a signal to obtain turbulent dissipation levels has also been done in the past by employing an integrating analog circuit before recording on the FSK system (Khalsa and Businger, 1977).

With the appearance of microprocessing units on the market, it became possible to routinely perform part of the computations necessary for flux determinations at the time of data collection in real time.

One specific application of the system was calculation of the relevant cross products discussed above averaged over one minute plus the mean values of the variables over the same time interval at a Mast for Studies of Microscale Air Sea Transfer (MS MAST) in Lake Washington. A second application was in obtaining one minute averages of eight channels of radiation data on a ship during the Joint Air Sea Interaction Experiment (JASIN) 1978 in the North Atlantic. A micro-computer system capable of handling the 429 samples/sec delivered by our digitizing unit is based on the IMSAI-8080 microcomputer.

Data Description

Thirteen meteorological signals are digitized in turn by a 12-bit A/D converter at a rate of 33 samples/sec for a total data rate of 429 values/sec. The digitized values are summed into 32-bit totals

throughout the averaging period. All 15 possible cross products of the first five meteorological channels are computed producing 15 32-bit products which are also summed into 48-bit totals throughout the averaging period (two velocities, one wind direction and dry- and wet-bulb temperatures).

At the end of the averaging period, the 32-bit totals and the 48-bit totals are divided by the number of values summed to give averages which can be printed and/or recorded on a floppy disk. The averages and cross product averages allow the variance and cross correlations to be easily calculated using a pocket calculator at the experimental site.

Hardware Description

Figure 1 shows the MS MAST data acquisition hardware. Each meteorological instrument on the tower has an analog signal line returning to the recording system located on shore. The FSK system digitizes and multiplexes all the signals and transmits the digitized voltages as a series of audio coded bits to an audio tape recorder. The digitizer voltages are also sent to the IMSAI microcomputer which calculates averages and cross product averages and records them on the teletype printer and on the floppy disk. The microcomputer also uses two D/A converters to drive a laboratory oscilloscope to display the incoming data so that inactive instruments may be easily spotted.

Software Description

The MS MAST data acquisition program is made up of four assembly language modules:

1. MS MAST: This is the main program, the multiply and summation routines for the data processing, the data input interrupt service routine and real time clock interrupt service routine (810 statements).
2. CLP: This is the Command Line Processor which processes information typed by the user to control the operation of MS MAST (741 statements).
3. NASKPAK: This is the multiprecision binary to ASCII and ASCII to binary conversion and teletype I/O module (837 statements).
4. FLOPPY: This is the routine which records data on the floppy disk (166 statements).

Software Development

The data acquisition software is a large assembly language program composed of the four separately assembled modules described above. Three of the four modules are over 800 statements long and each constitutes a large amount of text to be manipulated. Just printing the assembly listing on the IMSAI's teletype printer would take over half an hour (at 10 characters/sec). The need for high speed peripherals to facilitate software development is apparent. A hardware interface between the IMSAI microcomputer and the Atmospheric Sciences Department's RAYTHEON 704 minicomputer gave access to the required peripherals (see schematic layout in Figure 2).

A floppy disk based operating system called CP/M was purchased for the IMSAI microcomputer from Digital Research Corporation. CP/M provided a convenient file system for the floppy disk plus assembler, and several utility programs. The I/O system for CP/M was modified so that the input drives for RDR (paper tape reader) and the output drives of the LST (line printer) and PUN (paper tape punch) were talking to the RAYTHEON IMSAI interface. Software was developed for the RAYTHEON to send and receive files of ASCII text to and from the IMSAI.

The data acquisition software was developed as follows: The source statements for each module were stored on 7-track tape and edited with the RAYTHEON minicomputer. Next the source was copied from the RAYTHEON by the IMSAI to the floppy disk (about one minute). Next, IMSAI's assembler read the source and produced a listing file and a loader text file. The listing file was copied back and printed by the RAYTHEON on the higher speed printer (approximately three minutes required for 800 lines). Next, the loader text file was loaded from the floppy disk into the IMSAI and tested. The CP/M's trap trace routine (DEBUG) was used during testing. As errors were found, changes were noted on the listings and periodically (10 to 20 times a day) the source tapes were edited on the RAYTHEON to include the corrections and the above procedure was repeated.

This software development system has proved to be very effective. It has allowed us to produce a data acquisition system, which would have been prohibitively time consuming without the high speed peripherals.

Conclusions

Considering the working hours needed to convert two weeks worth of continuous recording of turbulence data at MS MAST, i.e. 336 hours, and six weeks of recording radiation data on a ship at sea, 1050 hours, we have already paid for the hardware acquisition in saved salaries.

Having a printer on site also provides real time first look digested data. In many cases this is helpful in directing the course of a field experiment.

Although many other units are available commercially, the fast data rate of the turbulence applications made the IMSAI-8080 advantageous for our purpose. The only disadvantage of the present system is that the programming was done in machine language and cannot be readily modified by the typical graduate student user.

Acknowledgments

We are indebted to Mr. Michael Intlekoffer for development of the hardware interfaces and to the Office of Naval Research Contract N00014-75-C-0502, MOD P00015 for financial support.

References

- Busch, N. E. 1973: On the mechanics of atmospheric turbulence, in Workshop on Micrometeorology, ed. D. A. Haugen, pp. 1-65, American Meteorological Society, Boston.
- Khalsa, S. J. S. 1978: The Intermittent Structure of Surface Layer Convection over the Tropical Ocean and its Significance in the Parameterization of Turbulent Fluxes. Ph.D. Thesis, Department of Atmospheric Sciences, University of Washington, 174 pp.
- Khalsa, S. J. S. and J. A. Businger, 1977: The drag coefficient as determined by the dissipation method and its relation to intermittent convection in the surface layer, Boundary Layer Meteorology, 12, 293-297.
- Stage, S. A. 1976: Profile Measurements in the Atmospheric Surface Layer over Lake Ontario during the International Field Year for the Great Lakes. M.Sc. Thesis, Department of Atmospheric Sciences, University of Washington, 93 pp.

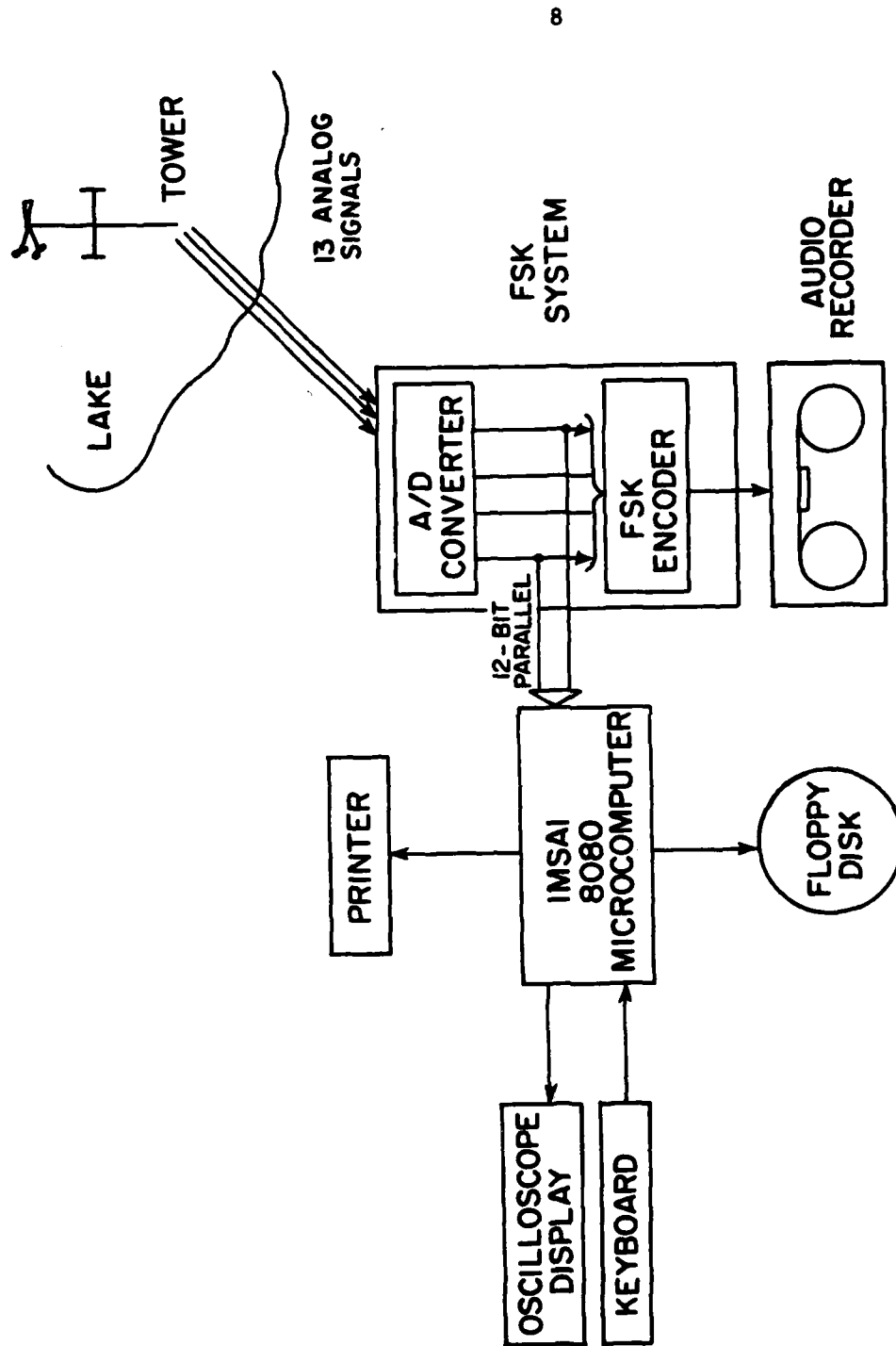

Fig. 1. Schematic of data collection hardware for the research mast for microscale air sea transfer (MS MAST) in Lake Washington.

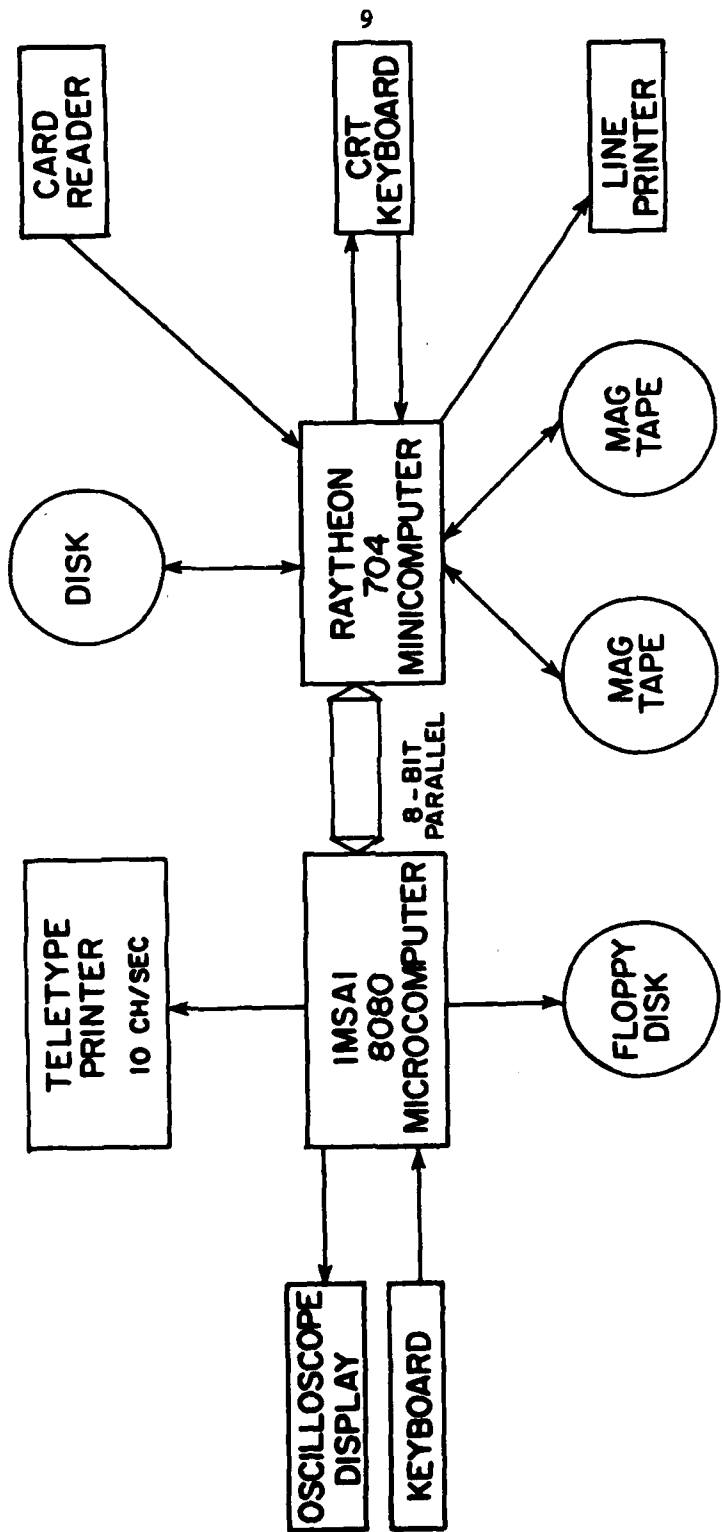

Fig. 2. Schematic of the interaction between physical units in the software development for the IMSAI 8080.

DATE
FILMED
8