

AD-A118 967

ARMY MATERIALS AND MECHANICS RESEARCH CENTER WATERTOWN MA F/6 11/9  
INTERACTIONS OF WATER WITH HYDROPHILIC POLYETHER POLYURETHANES. (U)

JUN 82 J L ILLINGER

UNCLASSIFIED

AMRC-TR-82-39

NL

1 of 2

ADA  
118967

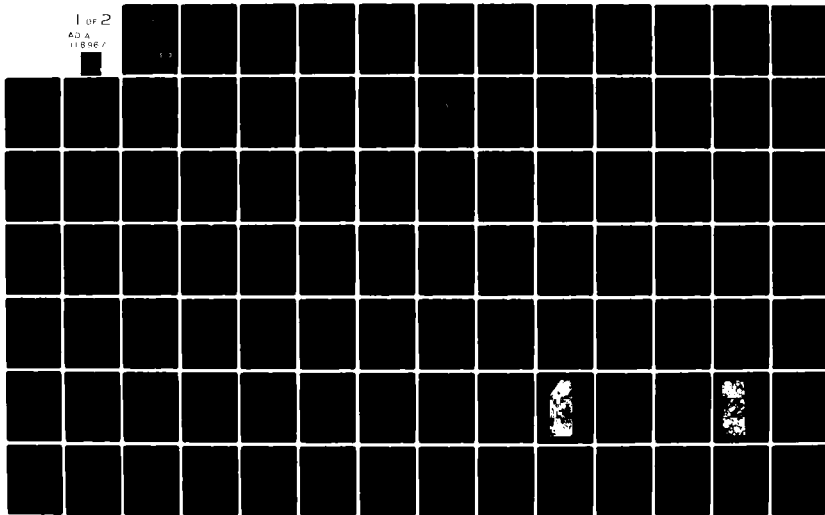

AD A118967

AMMRC TR 82-39

AD

12

# INTERACTIONS OF WATER WITH HYDROPHILIC POLYETHER POLYURETHANES

JOYCE L. ILLINGER  
POLYMER RESEARCH DIVISION

June 1982

DTIC  
ELECTE  
SEP 7 1982  
S D  
B

Approved for public release; distribution unlimited.

ARMY MATERIALS AND MECHANICS RESEARCH CENTER  
Watertown, Massachusetts 02172



UNCLASSIFIED

SECURITY CLASSIFICATION OF THIS PAGE(When Data Entered)

Block No. 20

ABSTRACT

Two series of polyurethanes based on MDI, butanediol and several block copolymer polyethers with varying proportions of poly(ethylene-oxide) PEO and poly(propyleneoxide) PPO have been synthesized. In series 1 the ratio of PEO to PPO is varied at fixed hard segment concentration. In series 2 the hard segment concentration is varied at a fixed 50/50 ratio of PEO to PPO. All of these materials are tough film forming elastomers of approximately the same molecular weight. At constant hard block composition and decreasing amounts of PEO in series 1 polymers, water uptake decreases from approximately 60% in the polymer with pure PEO to approximately 2% for the polymer with pure PPO at 30°C. These amounts of uptake increase as the temperature is decreased. The decrease in water uptake is most marked under immersion conditions or when the sorption isotherm is measured at saturation conditions. However, the trends are the same for both situations. When the hard block composition is varied a similar decrease in water uptake with increase in hard segment composition is seen although the degree of change is not so marked. The sorption isotherms are surprisingly simple concave upward curves which rise very steeply at saturation. Analysis of the data on the basis of moles of water per EO unit provides a picture of the influence of compositional variations on the course of the sorption isotherms and shows that saturation water concentrations are not related in a simple matter to PEO concentration. The diffusion coefficient,  $D$ , for water through these polymers decreases with increasing water concentration in the polymer and with decreasing temperature. Ethylene oxide content and hard segment content also effect the concentration dependence of  $D$ . Cluster function, size and number show very different behavior with water concentration from the pure propylene oxide soft segment polymer through block copolymer soft segment polymers to the ethylene oxide soft segment polymer.

Scanning calorimetry from 150 to 323°K has also been performed on these sets of polymers. The polymer samples with fixed amount of added water were equilibrated at 10° temperature intervals from 273 to 323°K. As equilibration temperatures  $T_{eq}$  were lowered the water melting endotherm diminished in size indicating that more water was bound to the polymer. The polymer soft segment  $T_g$  at the  $T_{eq}$  was close to that of dry polymer but decreased by as much as 40° with increasing  $T_{eq}$  in certain samples. It was found that the values of  $T_g$  correlate with the amount of bound water estimated from the DSC endotherm rather than with the total amount of water added to the polymer. The results could be accounted for in terms of the standard free volume theory of diluent depression of  $T_g$ . However, the  $T_g$  depression in the PEO polymer is larger than expected from these calculations, suggesting that there are additional effects due to water polymer interactions.

vi

UNCLASSIFIED

SECURITY CLASSIFICATION OF THIS PAGE(When Data Entered)

DEDICATION

To all of those people who have supported, encouraged and worried with me as I have pursued this degree.

Accession For	
NTIS GRA&I	<input checked="" type="checkbox"/>
DTIC TAB	<input type="checkbox"/>
Unannounced	<input type="checkbox"/>
Justification	
<i>PER CALL JC</i>	
By _____	
Distribution/	
Availability Codes	
Dist	Avail and/or Special
<i>A</i>	

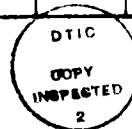

## TABLE OF CONTENTS

<b>Abstract</b>		vi
<b>Chapter I</b>	<b>Introduction</b>	1
<b>Chapter II</b>	<b>Low Temperature Dynamical Mechanical Properties of Polyurethane-Polyether Block Copolymers</b>	5
<b>Chapter III</b>	<b>Water Vapor Transport in Hydrophilic Polyurethanes</b>	25
<b>Chapter IV</b>	<b>Interaction of Water with Hydrophilic Polyether Polyurethanes: Scanning Calorimetric Studies</b>	50
<b>Chapter V</b>	<b>Interaction of Water with Hydrophilic Polyether Polyurethanes: Sorption and Diffusion Studies</b>	77
<b>Recommendations</b>		120

## LIST OF TABLES

## CHAPTER III

Table I	Glycol Composition and Structure	30
Table II	Sample Characterization	30
Table III	Immersion Water Uptake at 30°C	34
Table IV	Change in $T_g$ with Water Uptake	40
Table V	Permeation and Diffusion Behavior	44

## CHAPTER IV

Table I	Variation of Glycols	54
Table II	Polymer Composition	54
Table III	Equilibration Conditions	54
Table IV	Immersion Uptake at Various Temperatures	61
Table V	Added Water	61
Table VI	$\Delta T_g$ and Water on PEO	68
Table VII	$T_g$ Measured and $T_g$ Calculated from Diluent Depression	74

## CHAPTER V

Table I	Variation in Glycol	80
Table II	Polymer Composition	80
Table III	Inverse Henry's Law Coefficients	91
Table IV	Immersion Uptake	93
Table V	Immersion Uptake (Molecules $H_2O/EO$ unit)	93
Table VI	Diffusion Coefficients	115
Table VII	Diffusion Coefficients	117

## LIST OF FIGURES

## CHAPTER II

Figure 1	Temperature Dependence of Storage Modulus of Polyurethane Samples 1-3 at 110Hz	10
Figure 2	Temperature Dependence of Loss Tangent of Samples 1-3 at 110Hz	11
Figure 3	Temperature Dependence of Storage Modulus of Polyurethane Sample 4 at 110Hz	12
Figure 4	Temperature Dependence of Loss Tangent of Sample 4	13
Figure 5	Storage Modulus for Sample 5 at 110Hz	15
Figure 6	Loss Tangent for Sample 5 at 110Hz	16
Figure 7	DSC Results for Polyurethane Samples 1, 2, 5	17
Figure 8	DSC Results for Polyurethane Samples 3 and 4	18

## CHAPTER III

Figure 1	Sorption Isotherms for Polymers with Variation In Amount of Hard Segment at 50/50 PPO/PEO Soft Segment	36
Figure 2	Sorption Isotherms for Polymers with Variation In PPO/PEO Ratio in Soft Segment at Fixed Hard Segment Composition	37
Figure 3	Sorption Isotherms Plotted as the Ratio Molecules $H_2O/EO$ Unit	39
Figure 4	DSC Traces for 5PE33 with Varying Amounts of Added Water	42
Figure 5	Dependence of Diffusion Constant on Water Concentration	45

## CHAPTER IV

Figure 1	Polyurethane Structures	53
Figure 2	Sample Pan Configurations	56

Figure 3	Immersion Uptake	60
Figure 4	$T_g$ vs $T_{eq}$ In SPE28	62
Figure 5	$T_g$ vs $T_{eq}$ In OPE33	64
Figure 6	Endothermic Water vs $T_{eq}$ In SPE28	65
Figure 7	"Bound" Water vs $\Delta T_g$ (Hard Segment Variation)	67
Figure 8	Transmission Electron Micrographs SPE28, SPE33, SPE40	69
Figure 9	"Bound" Water vs $\Delta T_g$ (Soft Segment Variation)	70
Figure 10	Transmission Electron Micrographs OPE33, SPE33, 10PE33	71
Figure 11	$\Delta T_g$ measured vs $\Delta T_g$ calculated	75
CHAPTER V		
Figure 1	Polyurethane Structures	79
Figure 2	Mask for High MVTR Polymers	82
Figure 3	Sorption Isotherms 10PE33 T=15, 30, 50	84
Figure 4	Sorption Isotherms SPE33 T=15, 30, 50	85
Figure 5	Sorption Isotherms OPE33 T=15, 30, 50	86
Figure 6	Sorption Isotherms, Soft Segment Variation	88
Figure 7	Sorption Isotherms, Hard Segment Variation	89
Figure 8	Immersion Uptake	92
Figure 9	$\ln(\%H_2O/PEO)$ vs $1/T$ (soft segment)	94
Figure 10	$\ln(\%H_2O/PEO)$ vs $1/T$ (hard segment)	95
Figure 11	$\chi$ parameter, total polymer, soft segment variation	98
Figure 12	$\chi$ parameter, EO portion, soft segment variation	99
Figure 13	$\chi$ parameter EO portion, hard segment variation	100
Figure 14	Cluster Function: Total Polymer and PEO portion	102

Figure 15	Cluster Size: Total Polymer and PEO portion	103
Figure 16	Cluster Function T=50; OPE33, SPE33, IOPE33	105
Figure 17	Cluster Size T=50; OPE33, SPE33, IOPE33	106
Figure 18	Cluster Number T=50; OPE33, SPE33, IOPE33	107
Figure 19	Cluster Function T=30; SPE28, SPE33, SPE40	109
Figure 20	Cluster Size T=30; SPE28, SPE33, SPE40	110
Figure 21	Cluster Number T=30; SPE28, SPE33, SPE40	111
Figure 22	Diffusion Coefficient SPE28; T = 50, 30, 15	113
Figure 23	Diffusion Coefficient T=50, OPE33, SPE33, IOPE33	116
Figure 24	Diffusion Coefficient T=50, SPE28, SPE33, SPE40	118

## CHAPTER I

### INTRODUCTION

There is presently great interest in the use of hydrophilic polymeric materials for fabric coatings with high moisture vapor transmission, for use in reverse osmosis, biomedical applications, separation processes, etc. Many such materials (e.g. hydrogels) suffer from poor physical properties when wet and are brittle when allowed to dry out. Hydrophilic polyurethanes offer an attractive alternative in that they form tough, flexible films when dry. Depending upon compositional variations, a wide range of water vapor transmission rates can be obtained, accompanied by varying degrees of swelling with full retention of physical properties.

Polymer-penetrant interactions are usually studied by measurement of transport phenomena.<sup>1-3</sup> These interactions may be minimal as seen in the transport behavior of permanent gases. Concentration of penetrant in the polymer is directly proportional to pressure as is permeation with the diffusion coefficient constant. The interactions may be strong as is the case with organic solvents which swell various types of polymers. Transport behavior is highly concentration dependent with diffusion coefficients increasing with increasing solvent concentration due to plasticizing of the polymer. Fujita<sup>4</sup> has successfully treated this behavior using free volume theory. Water as a penetrant is of particular interest because of its ubiquity and anomalous behavior in many cases<sup>5-8</sup>

Diffusion coefficients frequently show marked decrease as concentration increases. This implies that not all water is free to diffuse and may be present as water "bound" to the polymer, as free monomeric or dimeric species, or effectively immobilized in large "clusters" within the polymer. Recent work, particularly by Barrie,<sup>8</sup> has examined the application of a simple condensation theory of water clustering to describe the diffusion behavior.

The purpose of this dissertation is to elucidate the nature of the interactions between water and this class of polymers using several different physical techniques. Differential scanning calorimetry (DSC) was used to examine the effect of water on the polymer as indicated by changes in the polymer  $T_g$ . The DSC also yields a measurement of water which is "free" or clustered within the polymer in large enough amount to show an endothermic water transition. Sorption techniques were used to obtain the isotherms representing the water uptake as a function of temperature. Various analyses<sup>1-4</sup> provide a measure of selective site sorption, Henry's Law sorption and clustered or condensed water. Techniques for obtaining estimates of the diffusion coefficient,  $D$ , from steady state transmission methods, or from kinetic analysis of the rate of sorption provide another means of assessing competitive effects of polymer swelling interaction and clustering of water.

By studying a systematically varied series of well characterized polymers it was expected that the effects and nature of these interactions could be related to controlling compositional variables. The

class of polyurethanes of interest here are the segmented polyurethanes built up of a polyether soft segment and a hard segment composed of MDI and butanediol. Previous studies<sup>9</sup> have shown that the nature of the soft segment affects sorption and transmission rates in this class of polymer. Other workers<sup>10</sup> have varied the amounts of separate hydrophilic and hydrophobic soft segments in similar polymers to markedly affect swelling and transport behavior. The availability of a series of block copolymer poly(ethyleneoxide) (PEO)/poly(propyleneoxide) (PPO) macroglycols offers another systematic approach to the same end, incorporating both hydrophobicity and hydrophilicity in all of the soft segments. Accordingly, a matrix of polymers (based on MDI, butanediol (B'd), and macroglycols) was synthesized, systematically varying soft segment composition and hard segment content. In one dimension of the matrix the mole ratio of MDI:Bd:polyol was fixed at 4:3:1 while hydrophobicity within the soft segments was varied by using symmetric PEO-PPO-PEO macroglycols with varying ratios of PEO/PPO. Pure PPO and pure PEO soft segment polymers were also made. In the other dimension of the matrix the 50/50 PEO/PPO macroglycol was used while the mole ratio of MDI:Bd was varied.

As the work progressed, two papers were presented and published. One was concerned with the dynamical mechanical characterization of the polymers and the other with water transport behavior of the polymers at 30° C. These appear as Chapters II and III of this dissertation. Chapters IV and V are two additional papers in manuscript form to be

submitted for publication. These chapters are thus self contained as to introduction, experimental, and results and discussion sections, as well as figures, tables, and references.

#### REFERENCES

1. Rogers, C. E. In "Physics and Chemistry of the Organic Solid State" Fox, D., Labes, M. M. and Weissberger A. eds, Interscience, New York 1965 Chap. 6.
2. Rogers, C. E. and Machin, D. CRC Critical Reviews of Macromolecular Science, p 254, April 1972.
3. Hopfenberg, H. B. ed, "Permeability of Plastics to Gases, Vapors and Liquids" Plenum Press, New York 1975.
4. Fujita, H., Fortschr. Hochpolym.-Forsch 3, 1 (1961).
5. Kunz, I. Q. and Kauzmann, W., Advances in Protein Chemistry 28, 239 (1974).
6. Schneider, N. S. ed "Selected Papers on Water Vapor Transport in Polymers", J. Macromol. Sci - Phys B3, No 4. (1969).
7. Molyneux, P. In "Water a Comprehensive Treatise" F. Franks ed Plenum Press (1975) Vol 4, Chap. 7.
8. Crank, J. and Park, G. S. ed "Diffusion in Polymers" Academic Press, New York 1968.
9. Schneider, N. S., Dusablon, L. V. Snell, E. W. and Prosser, R. A., J. Macromol. Sci-Phys B3, 623 (1969).
10. Chen, C. T., Eaton, R. F., Chang, Y. S. and Tobolsky, A. V., J. Appl. Polym. Sci. 16, 2105 (1972).

## CHAPTER II

LOW TEMPERATURE DYNAMIC MECHANICAL PROPERTIES OF  
POLYURETHANE-POLYETHER BLOCK CO-POLYMERS\*

## ABSTRACT

Dynamical mechanical relaxation spectra of a number of polyurethane-polyether block copolymers have been studied as a function of composition, temperature and frequency. At low temperatures these copolymers are characterized by a high glass-like modulus which decreases to a much lower typically elastomeric value in a narrow temperature range. The latter is a function in certain cases of the composition of the polymer. The rubbery plateau is maintained up to at least 140° C. In addition, a secondary relaxation is observed around -130°C. These observations can be interpreted in terms of an overall structure consisting of a polyether matrix containing segregated polyurethane domains, the latter serving as physical crosslinks in the system at ambient temperatures and above.

\* Presented at ACS Rubber Division Meeting, Miami Beach Fla, April 1971  
Published by Illinger, J. L., Schneider, N. S. and Darasz, F. E., in  
Polym. Eng. & Sci. 12, 25 (1972)

## INTRODUCTION

The polyurethane-polyether block polymers studied in this research are of the general structure:



Where M represents 4,4' methylene diphenyl diisocyanate, B is the chain extender 1, 4-butanediol, and S is a low molecular weight polyether consisting either of polyteramethylene oxide (PTMO) or a polypropylene oxide (PPO)-polyethylene oxide (PEO) block copolymer of structure.

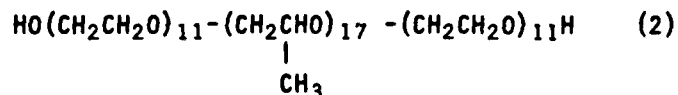

Polyether and polyester based urethanes of this general type have received much attention<sup>1-3</sup> in recent years largely because of their useful elastomeric properties and the possibility of performing molecular modifications on the basic structure to achieve a particular combination of properties.

Their mode of operation as elastomers is as follows: the "soft" polyether segments at room temperature (and, in fact, considerably below) form a flexible elastomeric matrix which is held together and prevented from flowing by the presence of the "hard" urethane M-B groups. Morphological studies have shown that the urethane groups are segregated and form domains or clusters which, because of the presence of crystallinity and/or inter-and intra-molecular hydrogen

bonding in the isocyanate group, retain their integrity up to 180°C. These domains function, therefore, as physical crosslinks. The designation of such elastomers thus is based upon a consideration of the glass transition and (in some cases) the melting transition temperatures of the individual blocks, together with a sufficient difference in the chemical nature of the two blocks to insure their incompatibility and hence their segregation in the matrix.

The purpose of the present study was to consider the dynamical mechanical properties of such systems as a function of temperature and to some extent of chemical structure. Such studies have been carried out on an extremely wide range of polymeric systems and because of their sensitivity to various types of relaxational phenomena, have constituted one of the most valuable methods for investigating such behavior from a molecular point of view<sup>4</sup>.

#### SAMPLES

Three elastomeric samples were studied in detail:

1. A polypropylene oxide polyethylene oxide based polyurethane in which the MDI:B:polyether ratio is 4.2:3:1 [from a consideration of the structure (1), it can be seen that there is basically a molar equivalence between MDI and (B + polyether). The excess 0.2 mole MDI is present in each case to insure an end capping of the polymer chain.]
2. A polyurethane of the same type as sample 1 but whose composition in terms of MDI:B: polyether is 3.2:2:1.
3. A commercial polyether polyurethane of the "Estane" series (5714) (Goodrich) in which the soft segment consists of a polytetramethylene oxide (PTMO) of molecular weight approximately 1,000 and the

molar ratio MDI:B: PTMO is 3.2:2:1.

In addition some studies were performed on two further samples:

4. An elastomer again based on a PTMO block (molecular weight 2,040) whose composition in terms of MDI:B:polyether is 2.2:1:1.

5. An MDI-butanediol polymer containing no polyether soft segment was also prepared (molecular weight 13,000). This did not of course display elastomeric properties at ambient temperatures.

The number average molecular weights of samples 1 to 3 were, respectively, 42,000, 39,000, and 55,000.

These samples were synthesized by well known techniques<sup>5</sup>: the polyether was first reacted with excess MDI to form a prepolymer MSM which was then further condensed with the appropriate amount of butanediol to produce the final polymer.

The samples used in the measurements described below were prepared from 10% dimethyl formamide solutions of their respective polymers by casting on glass plates and drying the resultant films in vacuum at room temperature for 48 hours.

#### MEASUREMENTS

Dynamical mechanical measurements were performed on the various samples using a model DDV-11 Rheovibron over the temperature range, approxi-

mately, of  $-150^{\circ}\text{C}$  to  $+150^{\circ}\text{C}$ . Measurements were made at 3.5, 11 and 110 Hz.

Thermal studies of the samples were carried out using a Perkin-Elmer differential scanning calorimeter, Model DSC-1B at heating rates of  $20^{\circ}\text{C min}^{-1}$ .

### RESULTS

The real component  $E'$  of the complex tensile modulus  $E^*$  and the loss tangent  $\tan \delta$  (defined as  $E''/E'$ ) are shown for samples 1 - 3 in Figs 1 and 2. They show generally somewhat similar behavior, characterized by a high glass-like modulus of approximately  $10^{10}$  dynes  $\text{cm}^{-2}$  up to about  $-60^{\circ}\text{C}$ , followed by a sharp decrease in  $E'$  to a relative plateau region above  $0^{\circ}\text{C}$ . Above about  $120^{\circ}\text{C}$ , the modulus was observed to gradually decrease (measurements were not possible below an effective  $E'$  about  $5 \times 10$  dynes  $\text{cm}^{-2}$ ). In a corresponding  $\tan \delta$  curve (Figure 2) the major loss (at 110 Hz) is observed at about  $-30^{\circ}$  as expected from the  $E'$  data; in addition a further secondary loss is observed (prominent in samples 1 and 3) at about  $130^{\circ}\text{C}$ .

The corresponding data for Sample 4 (2.2:1:1) is more complex. The large decrease in  $E'$  (Fig 3) begins at a lower temperature,  $-120^{\circ}\text{C}$  and is followed at  $-60^{\circ}\text{C}$  by an increase to about  $10^9$  dynes  $\text{cm}^{-2}$  before dropping to about  $10^8$  dynes at about  $0^{\circ}\text{C}$ . No measurements above room temperature were carried out for this sample because of the decrease in

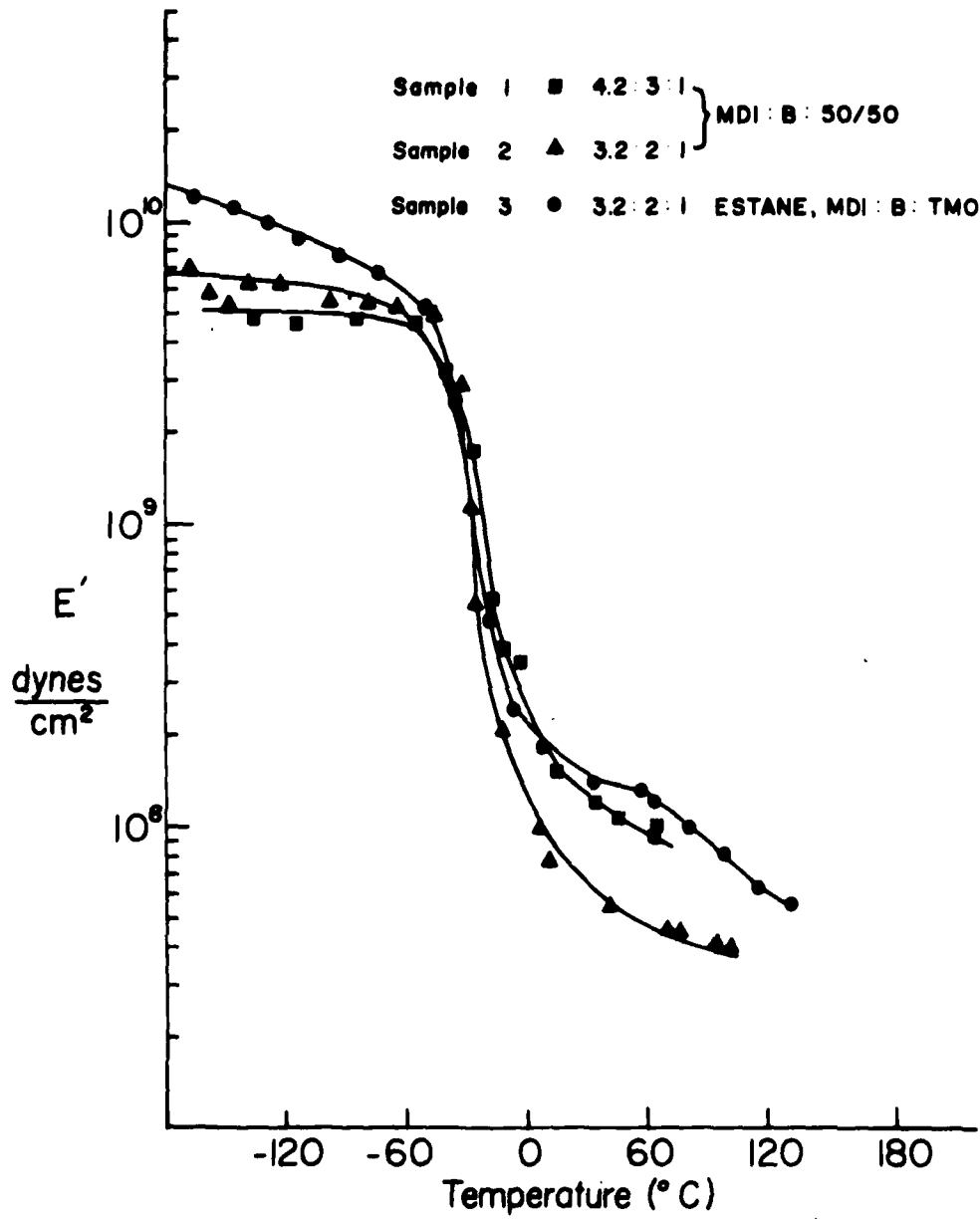

Figure 1. Temperature dependence of storage modulus of polyurethane samples 1-3 at 110 Hz.

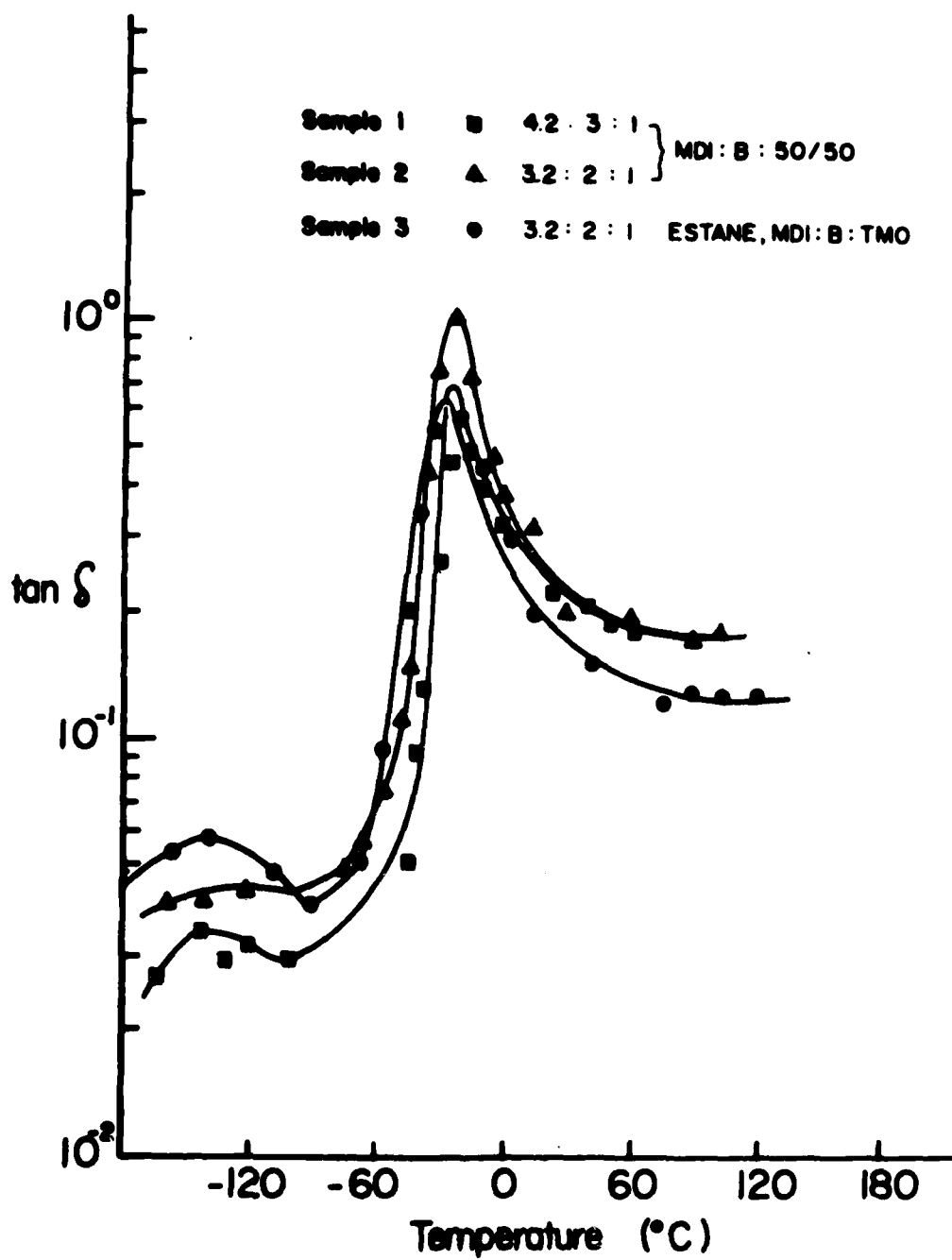

Figure 2. Temperature dependence of loss tangent of samples 1-3 at 110 Hz.

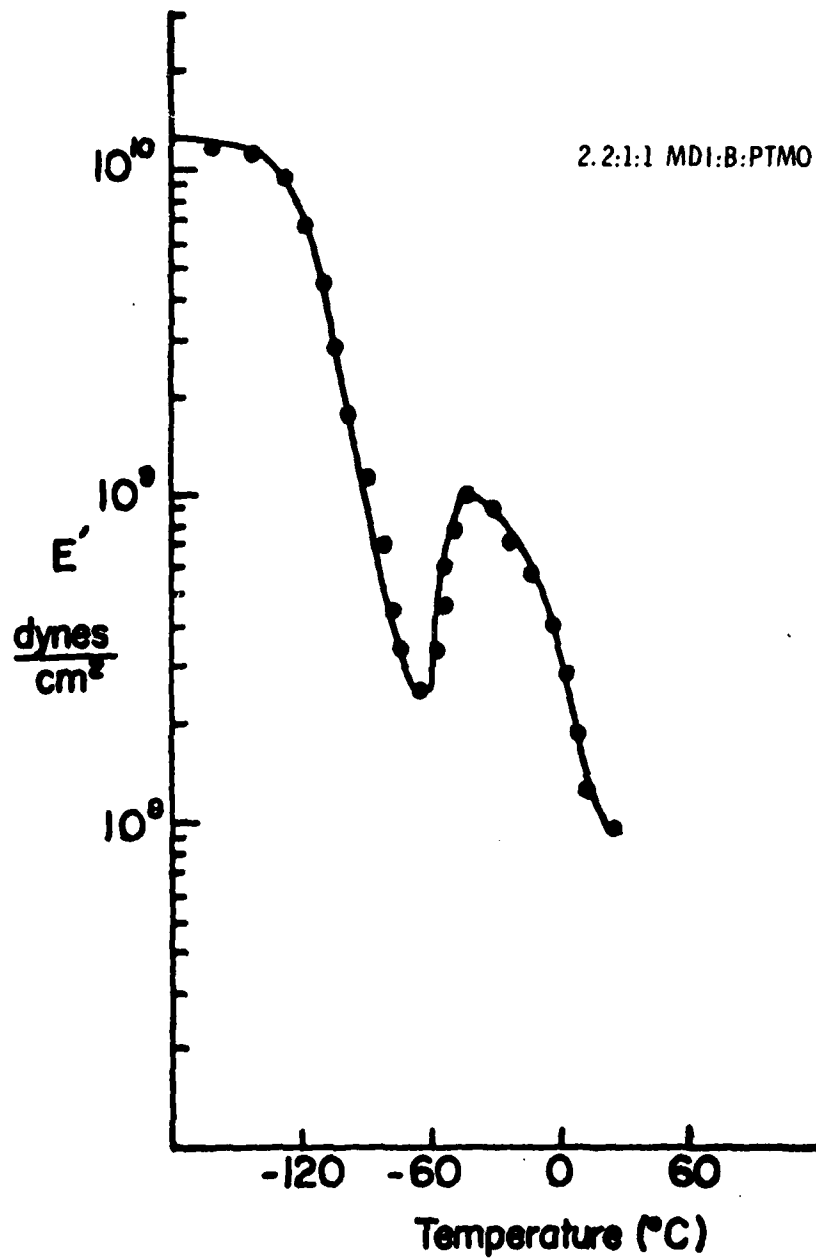

Figure 3. Temperature dependence of storage modulus of polyurethane sample 4 at 110 Hz.

modulus. The  $\tan \delta$  curve (Fig 4) is consistent with these observations: the rise seen in  $E''$  at  $-40^\circ$  is observed as a shoulder of the major  $\tan \delta$  loss peak centered about  $-90^\circ\text{C}$ . There is some evidence also for a secondary relaxation at about  $-140^\circ\text{C}$ .

The dynamical mechanical properties of the urethane containing no polyether segment (sample 5) was, as anticipated, completely different. The sample is characterized by a high glass-like modulus which gradually decreases above  $0^\circ\text{C}$ ., but still maintains a relatively high value ( $10^9$  dynes  $\text{cm}^{-2}$ ) up to about  $110^\circ\text{C}$  (Fig 5). At this point a decrease in  $E'$  due to the glass transition in the amorphous phase present is seen, followed after a short rubbery plateau by a further sharp decrease in  $E'$  as the melting transition is approached. The  $\tan \delta$  shows (Fig 6) in addition to a loss associated with  $T_g$ , a high temperature relaxation at approximately  $170^\circ\text{C}$ , also a previously characterized loss maximum at  $-30^\circ\text{C}$ .

The results of the differential thermal scanning data (Figs 7 and 8) may be summarized as follows: elastomeric samples 1 - 3 display a discontinuity in  $C_p$  which, although broad, may be readily interpreted as characteristic of the glass transition, all at least  $-40^\circ$  to  $-30^\circ\text{C}$ . In sample 4 containing the least relative amount of "hard" segment,  $T_g$  discontinuity appears at about  $-70^\circ\text{C}$ ; in sample 5 (no polyether) no discontinuity was observed up to about  $20^\circ\text{C}$ .

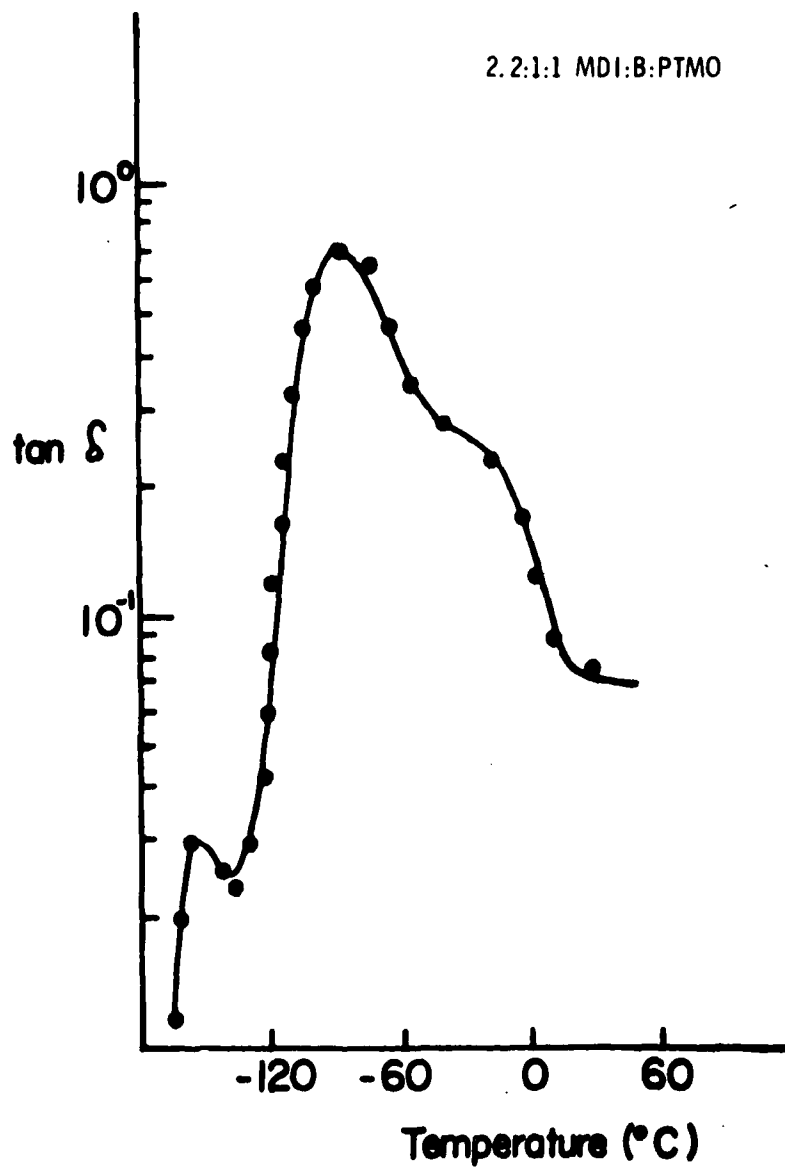

Figure 4. Temperature dependence of loss tangent of sample 4.

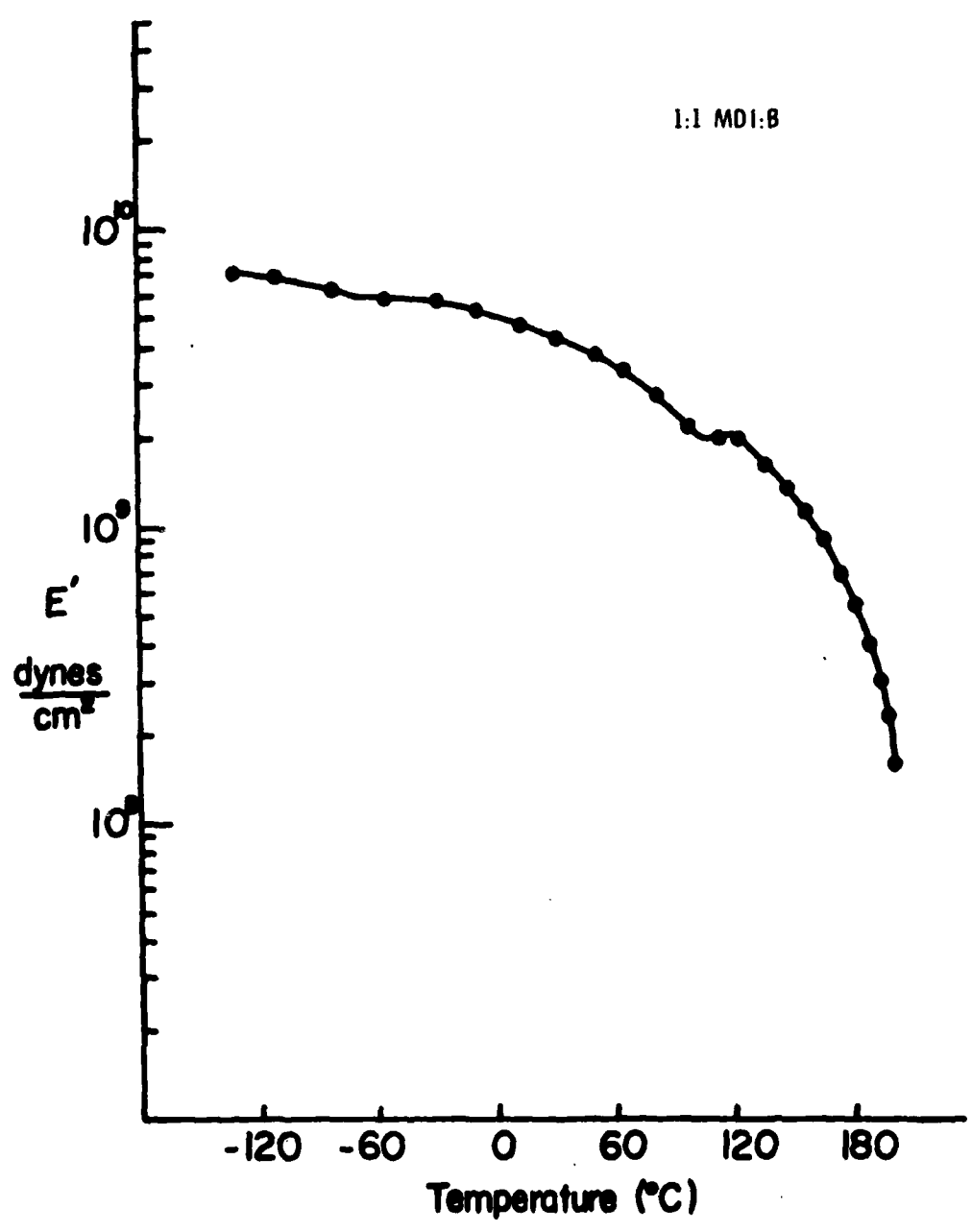

Figure 5. Storage modulus for sample 5 at 110 Hz.

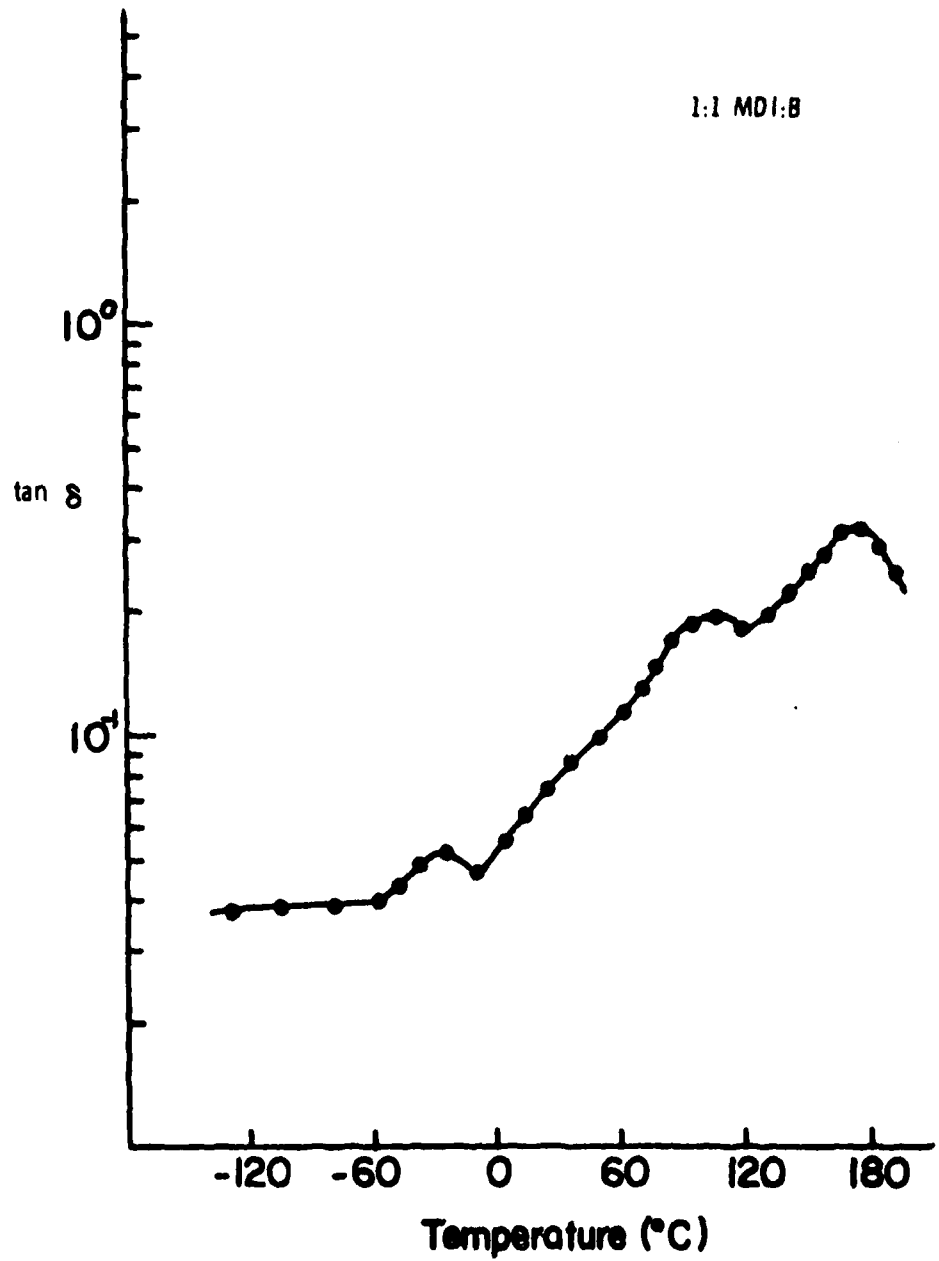

Figure 6. Loss tangent for sample 5 at 110 Hz.

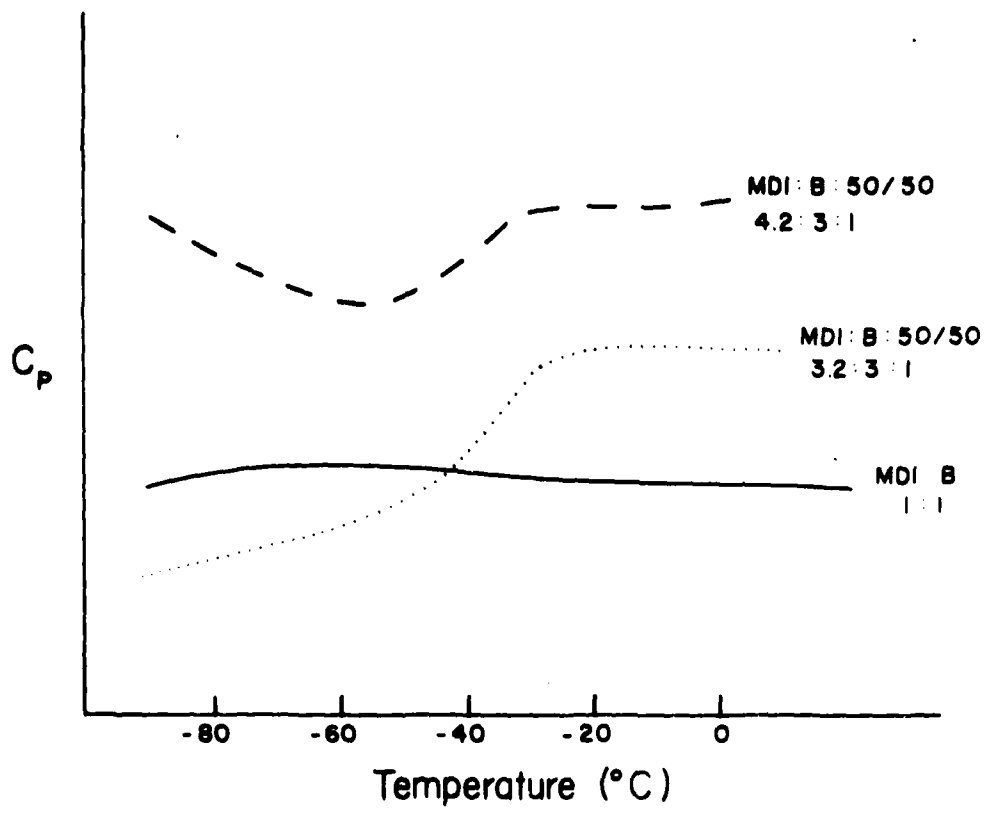

Figure 7. DSC results for polyurethane samples 1, 2 and 5.

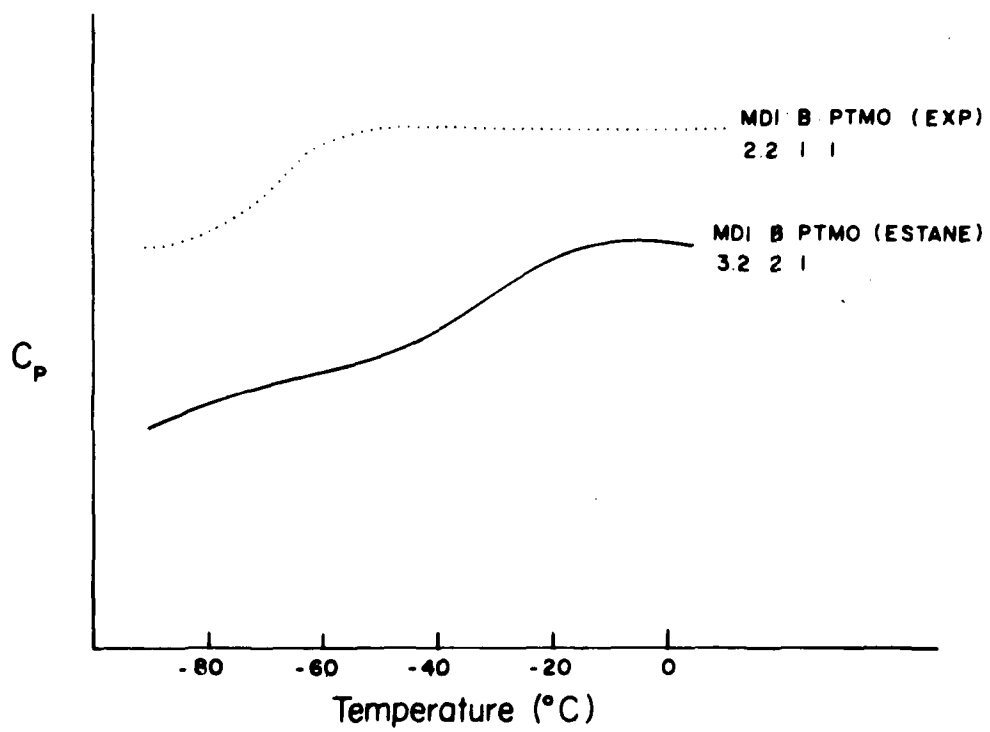

Figure 8. DSC results for polyurethane samples 3 and 4.

## DISCUSSION

These results overall are consistent with the model for polyurethane elastomers that has emerged from a variety of other studies. At low temperatures a glassy matrix is present which, in samples 1, 2 and 3, starts to soften at about  $-60^{\circ}\text{C}$ , because of the advent of the glass rubber transition in the respective polyether block.  $T_g$ 's for high molecular weight PTMO, PPO and PEO are  $-88^{\circ}\text{C}$ <sup>7</sup>,  $-75^{\circ}\text{C}$ <sup>8</sup>, and  $-76^{\circ}\text{C}$ <sup>9</sup>, respectively, and we would expect the apparent  $T_g$ 's in the polyurethanes to be in this range. The effect of the restriction of the ends of the short polyether blocks by the relatively immobile urethane groups segregated into domains must be to raise the  $T_g$  of the former. In these block copolymers this effect more than compensates for the decrease in  $T_g$  we would expect to see in equivalent homopolymers because of their low molecular weight. The relatively small differences between Sample 3 (PTMO polyether) and samples 1 and 2 (PPO-PEO polyether) reflects the fact that this restrictive effect may be somewhat different for the various samples.

In sample 5 (no polyether) no large drop in the modulus is observed at low temperatures and the polymer remains brittle. Above  $110^{\circ}\text{C}$ , further softening of the urethane begins, presumably due to the onset of the melting process. However, we cannot necessarily assume that the urethane domains present in the block copolymers are similarly crystalline [In fact Cooper has recently found evidence for its absence in

somewhat similar samples<sup>10</sup>], since one of the effects of block copolymerization will be the inhibition of crystallization in segments that, as homopolymers, would normally crystallize.

Thus in samples 1 - 3 above 0°C, the polyether segments are in amorphous form (though homopolymers of a equivalent molecular weight would be partially crystalline) and give the polymer its basic elastomeric characteristics. The modulus of these samples at say, 60°C, lies between  $5 \times 10^7$  and  $1 \times 10^8$  dynes  $\text{cm}^{-2}$  according to sample; the higher value can be perhaps attributed to a relatively greater proportion of urethane present providing a higher effective degree of crosslinking.

The present measurements were not extended above 120°C; other recent research has shown that, in similar samples, the onset of a further relaxation process can be observed above this temperature, associated with softening of the urethane domains already noted.

The low temperature behavior of sample 4 (containing the least relative amount of urethane) is substantially different from that noted above for samples 1 to 3. We believe this can be explained on a molecular basis as follows: the smaller amount of urethane present is not sufficient to raise the  $T_g$  of the polyether by mobility restriction, consequently the larger decrease in modulus is observed at a much lower temperature, about -90°C, which is consistent with the expected  $T_g$  of homopolymer PTMO of molecular weight 1,000 subject to the imposed

restraint. Furthermore, in contrast to samples 1-3, the polyether with the particular thermal history used a rapid quench followed by heating at  $1^{\circ}\text{C min}^{-1}$  partially crystallizes after it acquires the necessary mobility above  $T_g$ : this effect is responsible for the large increase in modulus observed at  $-30^{\circ}\text{C}$ . The crystallites generated in situ then soften and melt; the latter process is completed by about  $30^{\circ}\text{C}$  consistent with the behavior of the equivalent homopolymer. The contrast in properties between Sample 4 and Samples 1 to 3 illustrates clearly the necessity of a sufficiently large hard segment to provide restraint and achieve the "normal" polyether polyurethane properties.

Apparently the average single MDI-B-MDI unit between the polyether segments in sample 4 is not adequate to meet this criterion. We would expect to find, therefore, that in Sample 4 the polyurethane domain structure, if present at all, is developed to a far lower degree.

Finally, we consider the secondary relaxation prominent at around  $-140^{\circ}\text{C}$  in samples 1-3, and also observable in sample 4 at about the same temperature. In the polyurethane homopolymer, sample 5, this low temperature transition is barely observable. Relaxations at these temperatures and frequencies have been observed in all of the homopolymers which are contained in the samples considered here. Thus, we may correlate the observed loss with the corresponding " $\beta$ " transitions [McCrum, Read and Williams<sup>4</sup>] in PTMO or PPO, or the " $\gamma$ " transition in PEO (very weak) or in the  $(\text{CH}_2)_4$  sequence in the butanediol. As this transition is very weak in sample 5, it seems likely that the last

possibility can be ruled out and the transition occurs in the polyether segments. This is consistent with the fact also, that the relaxation appears to be somewhat stronger in the PTMO-containing polymers. It may be further observed that according to the views presented above, these relaxations in homopolymers must be attributed to motion in the amorphous phase.

#### CONCLUSIONS

The study of dynamic mechanical and calorimetric data on the several polyether-polyurethanes has revealed certain effects of composition and structure on transition phenomena. The several samples display the glass transition and secondary transitions associated with the corresponding polyether homopolymers, but the glass transition is shifted to appreciably higher temperatures. This is apparently the result of restrictions to mobility which are due not merely to termination of the soft segment in the urethane unit, but also to participation of the urethane block in the domain structure. When the concentration of MDI and butanediol is reduced below a certain level, the polyether glass transition drops by 60°C, nearly to the value expected for the homopolymer, and crystallization of the polyether segment is observed.

This behavior suggests that the distributed urethane units are not capable of restricting mobility and crystallization, and the domain structure in this case must be nearly absent.

## ACKNOWLEDGEMENTS

We wish to thank E. Cilley for carrying out DSC measurements, and M. Roylance for assistance with rheovibron measurements. Gift of the sample of "Estane" elastomer by the B. F. Goodrich Chemical Company is gratefully acknowledged. This work was partially supported by Grant 4362AC5,6 from the Petroleum Research Foundation (FEK).

## REFERENCES

1. G. M. Estes, S. L. Cooper, and A. V. Tobolsky, J. Macromol. Sci-Rev. Macromol. Chem, C-4 313 (1970).
2. G. M. Estes, D. S. Huh, and S. L. Cooper In "Block Copolymers," S. L. Aggarwal, Editor, Plenum Press, New York (1970).
3. S. B. Clough and N. S. Schneider, J. Macromol. Sci-Phys, B2, 553 (1968).
4. N. G. McCrum, B. E. Read, and G. Williams, "Anelastic and Dielectric Effects in Polymeric Solids," J. Wiley and Sons, New York (1967).
5. D. J. Lyman, Rev. Macromol. Chem., 1, 191 (1966).
6. T. Kajiyama and W. J. Mac Knight, Macromolecules, 2, 254 (1969).
7. C. A. Clegg, D. R. Gee, T. P. Melia, and P. Tyson, Polymer, 9, 501 (1968).
8. R. H. Beaumont, B. Clegg, G. G. Gee, J. B. M. Herbert, D. J. Marks, R. C. Robert and D. Sims, Polymer, 7, 401 (1966).
9. B. E. Read, Polymer, 3, 529 (1962).
10. R. W. Seymour, G. M. Estes and S. L. Cooper, Bull. Am. Phys. Soc., 16, 365 (1971).
11. K. Schlieder and K. Wolfe (Kolloid Z. 134, 149) (1953).

## CHAPTER III

## WATER VAPOR TRANSPORT IN HYDROPHILIC POLYURETHANES\*

## SYNOPSIS

Water uptake and water vapor transmission rates have been obtained on two series of hydrophilic segmented polyurethanes based on MDI, butanediol and several block copolymer polyethers with varying proportions of poly(ethyleneoxide) PEO and poly(propyleneoxide) PPO. In Series I the ratio of PEO to PPO is varied at fixed hard segment concentration. In series II the hard segment concentration is varied at a fixed 50/50 ratio of PEO to PPO. At constant hard block composition and decreasing amounts of PEO in Series I polymers, water uptake decreases from 58g/100g of polymer at pure PEO to 2g/100g of polymer for pure PPO. Transmission rates determined with water in contact with the upstream surface and 50% relative humidity downstream show a corresponding decrease. As hard block concentration is increased in Series II both water uptake and transmission rate decrease. The sorption isotherms are surprisingly simple concave upward curves which rise steeply at saturation. Analysis of the data on the basis of moles of water per EO unit provides a clear picture of the influence of compositional variations on the course of

\* Presented at Borden Award Symposium, Los Angeles California, April 1974. Published by Illinger, J. L., Schneider, N. S. and Karasz, F. E. in "Permeability of Plastic Films to Gases, Vapors and Liquids", H. B. Hopfenberg ed, Plenum Press 1975

the sorption isotherms and shows that saturation water concentrations are not related in a simple manner to PEO concentration. The diffusion coefficients calculated from steady state transmission rates decrease with increasing water concentration in Series I but increase with water concentration in Series II. The apparently conflicting trends can be rationalized in terms of water clustering in the first case and the blocking effect of hard segment domains in the second. Comparisons are also made with results on a series of polyurethane-ureas based on Hylene W and containing a mixture of separate PEO and PPO macroglycols which were studied by Tobolsky and coworkers for reverse osmosis.

## INTRODUCTION

There is considerable present interest in hydrophilic polymers for reverse osmosis, biomedical applications and fabric coatings which can offer high moisture vapor transmission rates. The usual hydrogels suffer the disadvantage of being brittle when dry and may have poor physical properties in the wet state. Hydrophilic polyurethanes based on the incorporation of a poly(ethyleneoxide) soft segment remain flexible when dry and can provide very high moisture transmission rates<sup>1</sup>.

However the high transmission rates are accompanied by an unacceptably high degree of swelling (up to 100% by weight of dry polymer) and the loss of physical properties. Tobolsky<sup>2</sup> and coworkers have explored one approach to modifying the hydration behavior of polyurethanes based on the use of varied proportions of hydrophobic and hydrophilic polyethers as separate soft segments. The availability of several poly(propyleneoxide) (PPO) -poly(ethyleneoxide) (PEO) block copolymers offers another approach to the same end, incorporating both hydrophilicity and hydrophobicity in all of the soft segments of elastomeric polyurethanes. The present study is concerned with elucidating the effect of soft segment composition and urethane concentration on the polymer-water interactions, water sorption levels and permeability behavior of a series of such block copolyether polyurethanes.

## EXPERIMENTAL

Synthesis and Materials

MDI (4,4'-methylene diphenyl diisocyanate) was obtained from Mobay Chemical Co., vacuum distilled at 2 mm mercury HG and maintained liquid until polymerized to prevent dimerization.

1,4 butanediol was obtained from GAF Industries and used as received.

Glycols were obtained from Wyandotte Corporation (block polyols and PPO) and Union Carbide (PEO). Hydroxyl numbers were determined and a potentiometric titration performed to measure any residual basic material<sup>3</sup> which was then neutralized with an appropriate amount of etheric HCl. This was necessary to prevent the free base from catalyzing crosslinking reactions which lead to prepolymer gelation.

The polyurethanes were prepared by a two step synthesis. The first step involved end capping the macroglycol with excess diisocyanate at 83°C for one hour under vacuum (approximately 5 mm Hg) with stirring. Butanediol was added under flowing argon for chain extension. The resultant polymer was poured into a teflon lined pan and cured under vacuum at 110° C. overnight. Weights of the components were accurate to  $\pm 0.04$  grams and the OH/NCO ratio was 0.952 to control degree of polymerization. This synthesis produces a polymer of the general structure.

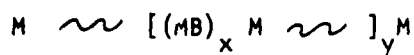

where M is MDI

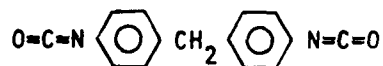

B is 1,4 Butanediol (B'd)  
HO CH<sub>2</sub>CH<sub>2</sub>CH<sub>2</sub>CH<sub>2</sub>OH

$\sim$  is a polymeric glycol  
HO(CH<sub>2</sub>CH<sub>2</sub>O)<sub>a</sub> (CH<sub>2</sub>CHO)<sub>b</sub> (CH<sub>2</sub>CH<sub>2</sub>OH)<sub>a</sub>  
CH<sub>3</sub>

Available polyols of  $\bar{M}_n$  2000 are listed in Table I.

Characterization data for the resultant polymers are shown in Table I. In the sample designation the first number represents the poly(ethylene-oxide) weight fraction of the block copolyether soft segment, the second number indicates the weight percent of urethane. Thus, SPE33 is a sample with 33% of MDI and with a soft segment which is 50% PEO. The three intermediate samples in this series have the same soft segment, a 50/50 copolymer of PEO and PPO but increasing urethane concentration. There are five samples with identical hard segment composition (33%MDI) but with the change in soft segment composition from 100% PEO in the first sample to 100% PPO in the last sample and all 2000 molecular weight. All samples are of moderately high molecular weight and in a range where the properties are expected to be sensitive only to the differences in molecular composition. The glass transition temperatures in the last column of Table II appear to depend only on the soft segment composition and are independent of changing MDI concentration. These  $T_g$  values were 25°C higher than the  $T_g$ 's of the pure soft segment polyol.

TABLE I

## Glycol Composition and Structure

<u>Glycol</u>	<u>Composition</u>	<u>a</u>	<u>b</u>
C1540	100% PEO	36	0
L35	50/50 PPO/PEO	11	17
L43	70/30 PPO/PEO	7	23
L61	90/10 PPO/PEO	2.5	33
P2010	100% PPO	0	35

TABLE II

## Sample Characterization

<u>Sample</u>	<u>Molar Composition</u> <u>MDI:Bd:Polyol</u>			<u>M<sub>n</sub> × 10<sup>-3</sup></u>	<u>T<sub>g</sub> °K</u>
10PE33	4.20	3	1C1540	22 1	242
5PE28	3.15	2	1L35	31 2	236
5PE33	4.20	3	1L35	38 2	236
5PE40	6.30	5	1L35	20 2	236
3PE33	4.20	3	L43	24 3	230
1PE33	4.20	3	1L61	21 1	---
0PE33	4.20	3	1P2010	23 1	232

### Sorption Measurements

Equilibrium water sorption measurements were performed by immersing a preweighed sample of polymer in distilled water maintained at 30°C. Samples were allowed to come to equilibrium (up to 16 hours) then removed from the water, blotted with two sets of filter paper and immediately placed in a tared weighing bottle. Weight gain was measured and samples returned to immersion for repeat determination.

Sorption isotherms were measured in a thermostatted vacuum system incorporating a five liter ballast volume for vapor, a silicone oil manometer to increase sensitivity for measuring pressure, and a Perkin-Elmer AR-1 recording electrobalance to continuously register weight gain.

### Transmission Measurements

Steady state bulk permeabilities were measured in inverted cup cells, the top being sealed by the polymer film of interest, which were placed in an Aminco Aire cabinet controlled at  $30^{\circ} \pm 0.5^{\circ}\text{C}$  and  $50 \pm 1\%$  RH. Periodic weighings were made to determine weight loss which was converted to flux and then to bulk permeability. Evaporation rate of water was measured at the same positions and conditions to obtain limiting values required by the flux equation of Reference 4.

### Scanning Calorimetry

Calorimetric measurements were made using a Perkin-Elmer DSC-2 equipped with sub-ambient accessory capable of controlling from 100° K. All scans were run at 20°/min. The wet polymer samples were prepared by placing a weighed sample of polymer in a volatile pan, adding a calculated amount of water, and then hermetically sealing the pan. The pan was reweighed to determine the actual amount of water added.

## RESULTS AND DISCUSSION

### Equilibrium Swelling Ratios

Results of the equilibrium water uptake experiments at 30°C are shown in Table III. The Table is organized into two sections. The upper section present the results for samples of varying PEO concentration at a fixed hard segment length, the lower section of the Table shows the results of varying hard segment lengths and 50% PEO 50% PPO soft segment compositions. The data showed two effects of polymer composition: (1) at fixed hard segment lengths, the increased per cent of ethylene oxide in the polymer is accompanied by increased sorption; and (2) the increased amount of hard segment decreases the water uptake. We will first discuss the influence of soft segment composition on water sorption referring to the results in the upper section of Table III.

Measurements on the copolymer of MDI and butanediol, representing pure hard segment, showed no measurable water uptake. Therefore all sorption

must occur in the soft segment regions of the polymer. Further, if it is assumed that the number of molecules of water per repeat unit bound to the central PPO portion of the segment remains fixed and independent of soft segment composition, then the sorbed water can be interpreted in terms of the ratio of molecules of water to ethylene oxide units. These values are shown in the last column of Table III. It is evident that the ratio is not fixed, but decreases progressively with increasing PPO content, indicating that the water sorption on PEO units is not independent of the composition of the soft segment region. If complete miscibility of hydrated PEO and PPO segment occurred then the water solubility behavior could be expected to conform simply to an additive mixing relation consistent with fixed characteristic ratios of molecules of water per PO unit and EO unit. It is known that PEO is completely soluble in water whereas PPO is not. Since PPO is the central block and increases in length with decreasing PEO concentration, these results suggest that phase incompatibility between PPO and PEO segments may be occurring in the hydrated state. The resulting association of PPO blocks would constrain swelling in PEO regions.

It is instructive to compare these results with the data obtained by Tobolsky and coworkers. We select for comparison the data in their Table VI for a series of polyurethane-ureas from Hylene W (the saturated version of MDI) with fixed hard segment composition and varying proportions of the separate 1000 molecular weight PPO and PEO segments. The water uptake in the six samples varies from 22 to 36% with increasing

TABLE III

Immersion Water Uptake at 30°C

Polymer	% PPO	% PEO	$\frac{\text{g H}_2\text{O}}{\text{g film}}$	$\frac{\text{Molecules H}_2\text{O}^*}{\text{EO unit}}$
10PE33	-	54	.58 ± .03	2.63
5PE33	30	29	.25 ± .02	2.02
3PE33	41	19	.08 ± .01	0.85
1PE33	55	6	.03 ± .005	0.49 <sup>+</sup>
0PE33	61	-	.02 ± .005	0.11 <sup>+</sup>
5PE28	34	33	.40 ± .03	2.88
5PE33	30	29	.25 ± .02	2.02
5PE40	25	24	.15 ± .01	1.45

\* Calculated assuming constant sorption levels on PPO

<sup>+</sup> Molecules H<sub>2</sub>O/PO unit

PEO content. Significantly, when their results are converted to the ratio of molecules of water per EO unit the values scatter between 3 and 4 and do not show any defined trend with composition. These results support the proposal presented above, that simple miscibility conditions do not exist for the hydrated block copolyether in our polymers.

The influence of increasing hard segment concentration on water sorption levels at fixed 50/50 PPO/PEO soft segment composition is shown with particular clarity by the sensitive variation in the ratio of molecules of water to EO Unit in Table III. Decreasing the urethane concentration from 33% to 28% allows even higher local sorption (indicated by the value of this ratio) than elimination of PPO completely from the soft segment. The general dependence of the swelling ratio when composition can be explained in terms of the increasing elastic modulus of the polyurethanes with increasing hard segment lengths and the corresponding increase in the elastic contribution to the free energy of mixing.

#### Sorption Isotherms

The sorption isotherms shown in Figures 1 and 2 are surprisingly simple being continuously concave upward and rising steeply at high relative humidities. The three isotherms for the samples with 50/50 polyether copolymer soft segment and varying hard segment composition shown in Figure 1, are very close up to a partial pressure of 0.7. The agreement

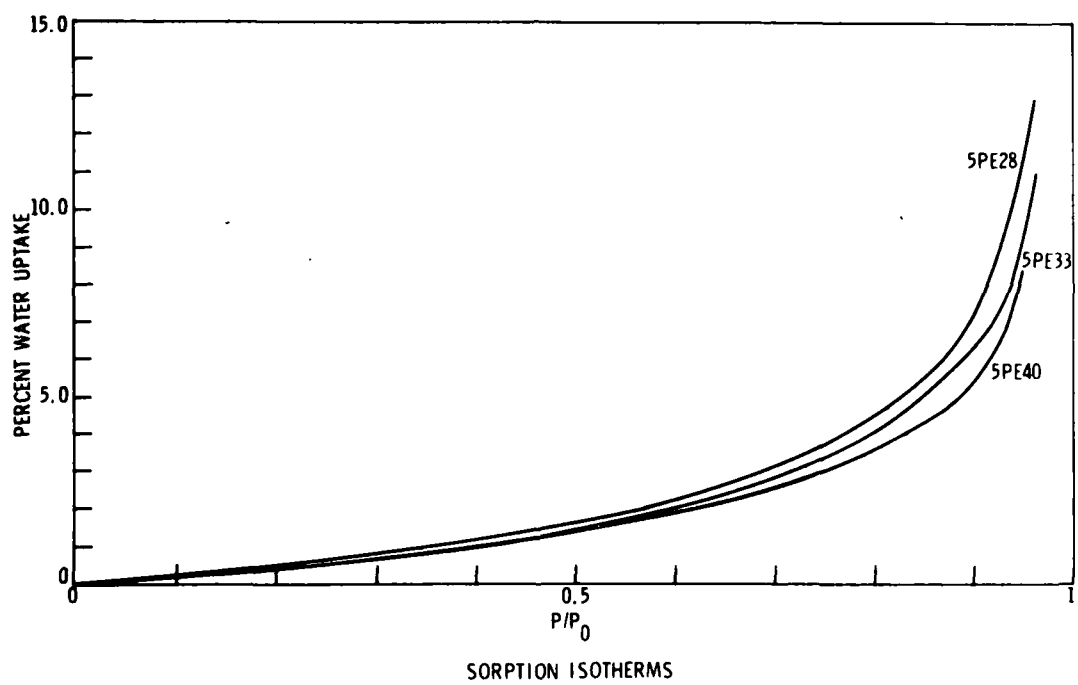

Figure 1. Sorption isotherms for polymers with variation in amount of hard segment at 50/50 PPO/PEO soft segment.

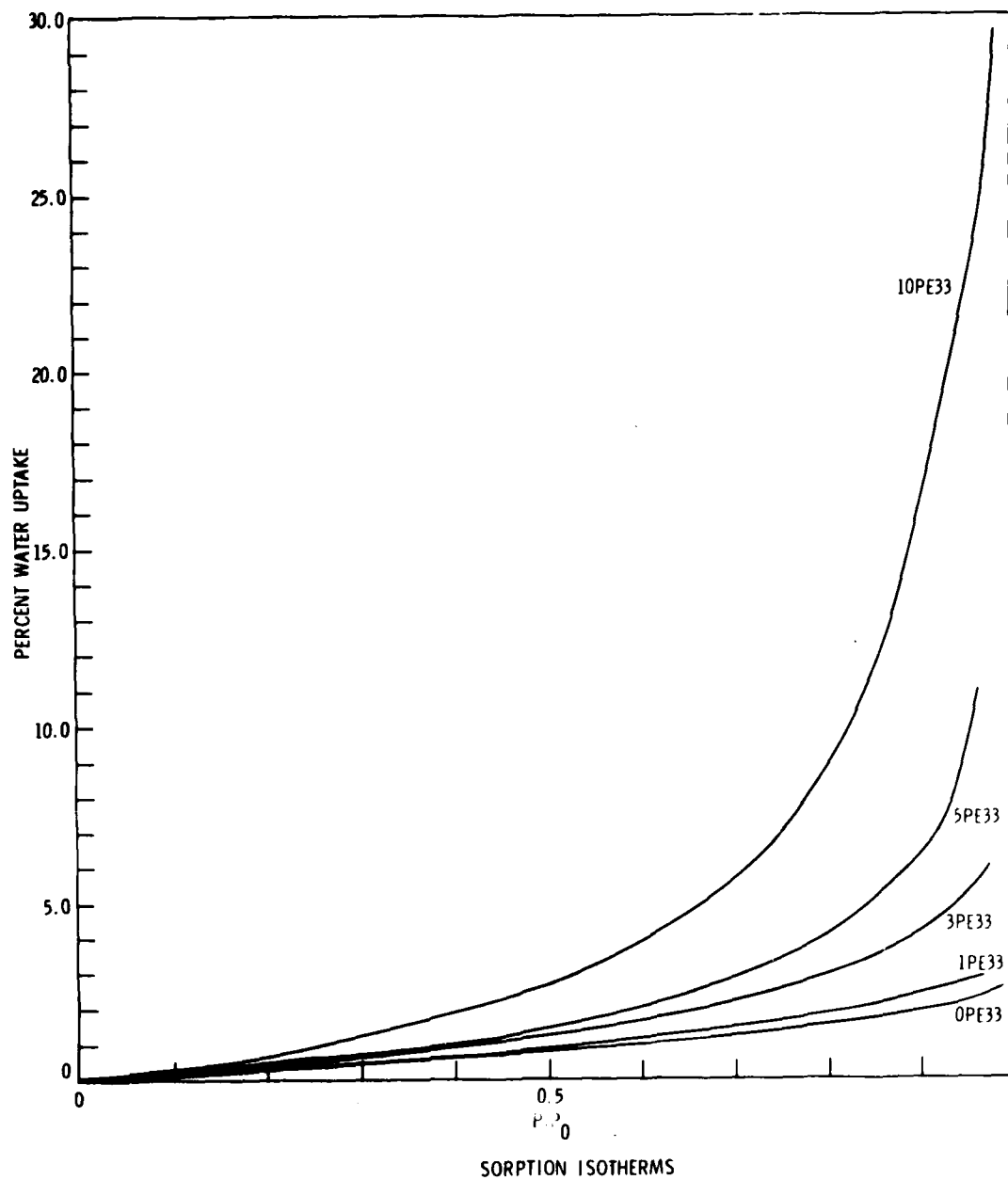

Figure 2. Sorption isotherms for polymers with variation in PPO/PEO ratio in soft segment at fixed hard segment composition.

in sorption behavior is more clearly displayed by comparison of the H<sub>2</sub>O/E0 ratio (Figure 3) where matching occurs up to  $p/p_0$  of 0.9 (see hatched area) corresponding to a maximum swelling of 8%. Apparently at or below this level of swelling, the change in free energy of mixing due to differences in elastic modulus of the samples is too small to affect the sorption behavior.

Figure 2 shows the isotherms for the samples with varying "soft" segment composition and fixed "hard" segment structure. Even at low humidity differentiation of the pure PEO polymer becomes apparent. The differences become more marked in comparing the H<sub>2</sub>O/E0 ratio (Figure 3). The PPO block affects sorption levels for  $p/p_0$  as low as 0.3. The PPO block shows more effect on the sorptive capacity of the E0 units at lower partial pressures than does hard segment size or elastic modulus change. The very much higher levels of sorption at very high values of  $p/p_0$  and on immersion are due to clustering of water in the highly swollen of materials.

#### Scanning Calorimetry

Some DSC studies were carried out to further elucidate the nature of the interactions between water and the polymer soft segment. One effect which was observed is the progressive decrease in soft segment glass transition with increasing amount of water. This is illustrated by the results in Table IV for 5PE33 which show an overall decrease of 11°C in the glass transition. In addition, it was possible to obtain information

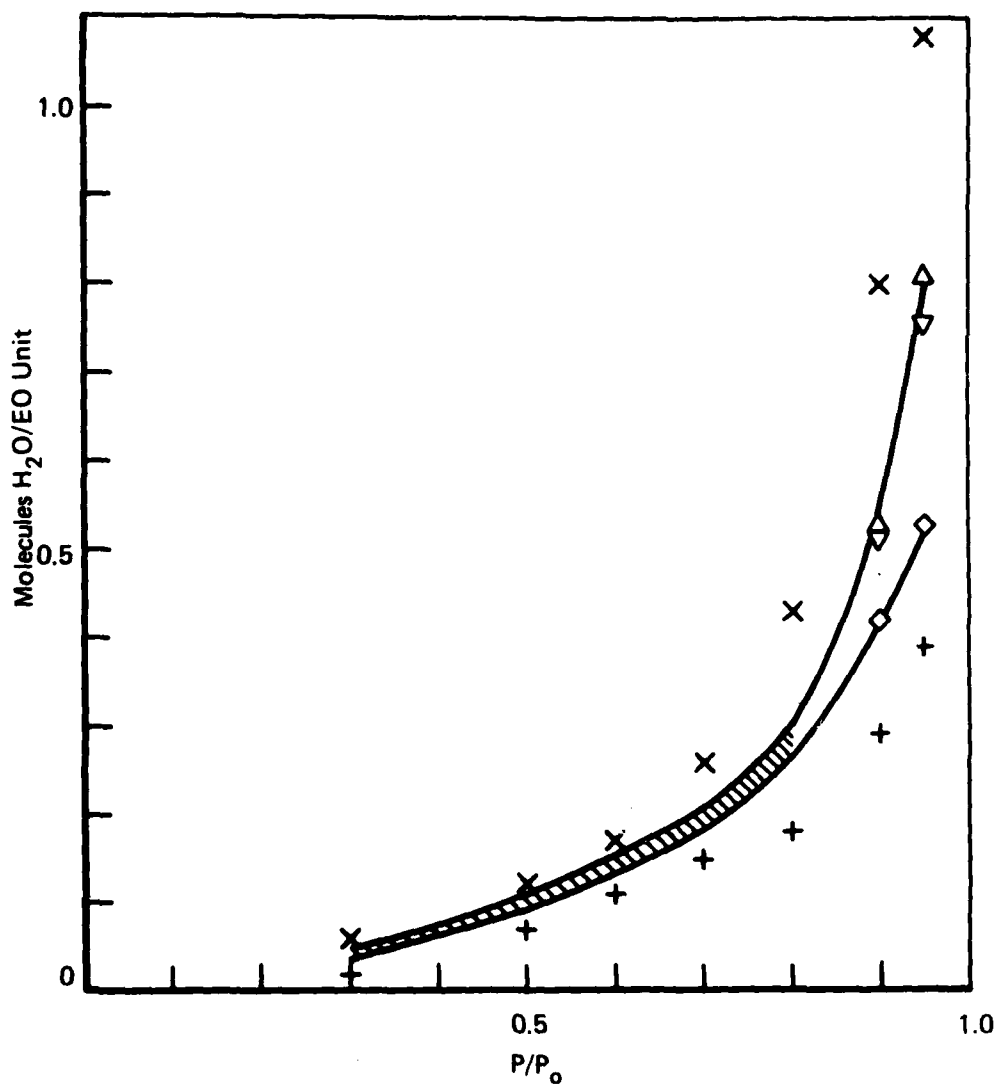

Figure 3. Sorption isotherms plotted as the ratio molecules H<sub>2</sub>O/EO Unit: (X) 10PE33, (+) 1PE33, (Δ) 5PE28, (▽) 5PE40, (◇) 3PE33. Hatched area shows matching of isotherms within limits of error.

TABLE IV

Change in  $T_g$  With Water Uptake  
(Sample SPE33)

<u>% H<sub>2</sub>O</u>	<u>T<sub>g</sub> (°K)</u>
0	237
4	233
8	231
18	226

concerning the state of sorbed water. As shown in Figure 4, up to 8% added water there is no separate contribution of water to the DSC trace, indicating that it is all bound to the polymer.

At 18%, well below the 30°C equilibrium uptake of 25% water, sufficient "free" or "clustered" water is present to show a sharp ice melting endotherm. A smaller endotherm was seen at 14% water. The 8% uptake is found at a partial pressure of about 0.9 and is equivalent to one molecule of water per two units of ethylene oxide while at 14% uptake this ratio is one to one. Further work is needed to determine the ratio at which "bulk" water behavior is first observed.

#### Bulk Permeabilities

Permeabilities were calculated from the steady state flux at 30°C measured with liquid water in contact with the film and 50% relative humidity down stream. Equation 1 (Reference 4) was applied to correct for the limiting evaporation rate of water

$$J^{-1} = mL + b \quad (1)$$

Here J is the observed steady state flux, 1/m is the bulk permeability, L the film thickness and 1/b the evaporation rate of water. Integral diffusion coefficients, D, were estimated from the above determined values of the bulk of permeability in units of gm-mil/100 in<sup>2</sup> 24 hours

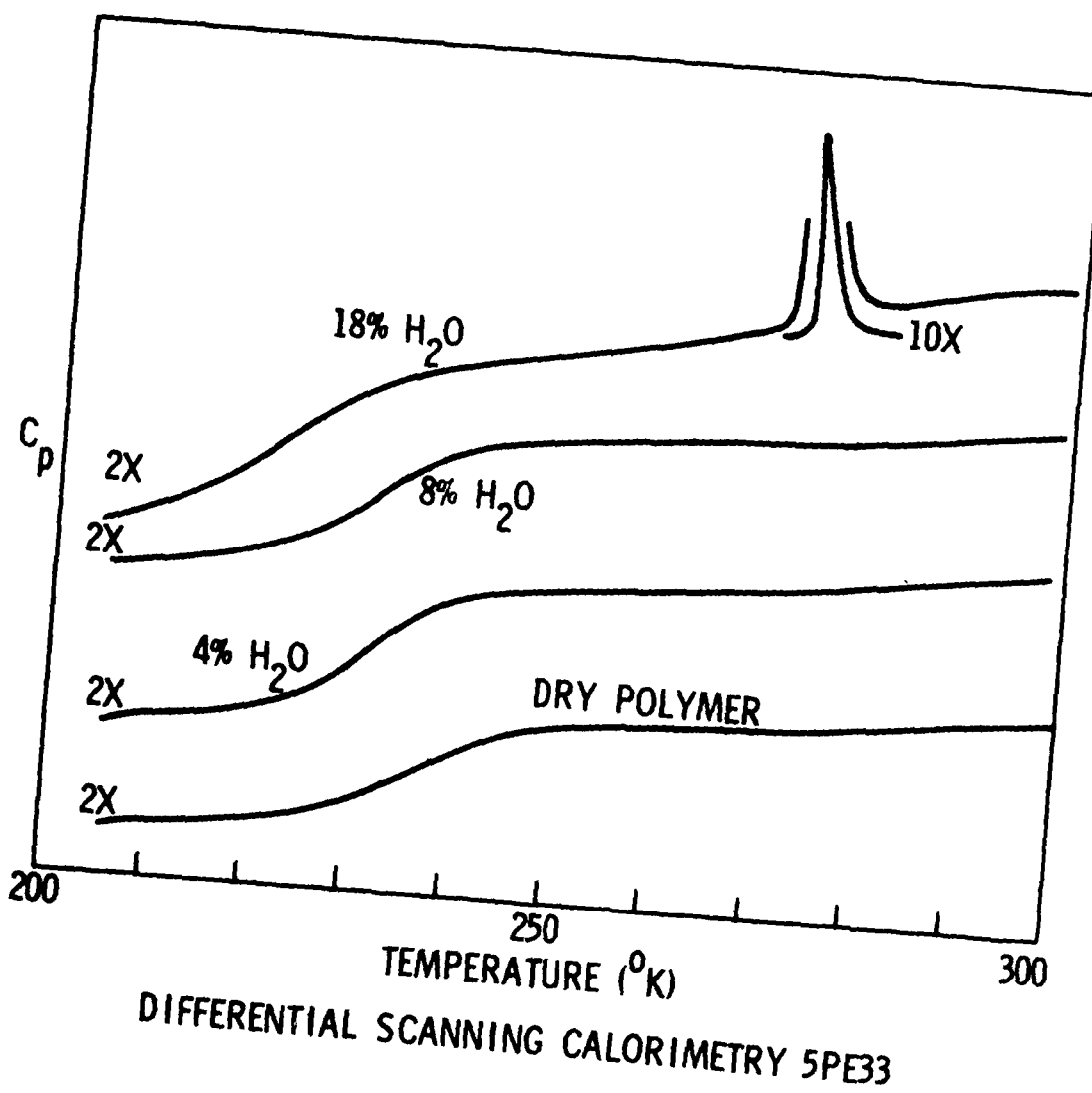

Figure 4. DSC traces for 5PE33 with varying amounts of added water.

using the relation

$$D = \frac{(1-v_1)}{m(C_2-C_1)} \quad (2)$$

where  $(C_2-C_1)$  is the difference in water concentration across the film. The additional term  $(1-v_1)$ , where  $v_1$  is the equilibrium upstream volume fraction of water, is required for highly swollen films to convert from a fixed polymer frame of reference to the fixed volume frame of reference appropriate to the calculation of a mutual diffusion coefficient. The results are summarized in Table V and plotted in Figure 5. The measurements on 10PE33 show large error limits due to the extremely high flux levels (490 gm/100 in <sup>2</sup>/24 hours for a 1.7 mil film) which approached the evaporation rate of water (660 gm/100 in <sup>2</sup>/24 hours) under our conditions. Values of permeability and diffusivity are included for completeness. Two opposing trends are evident in the dependence of the diffusion constant on water concentration. In the five samples in the upper section of Table V with fixed urethane concentration the diffusion constant decreases progressively with increasing water concentration. For the samples in the lower portion of the Table with fixed PEO/PPD ratio, the diffusion coefficient increases with increasing water concentration. This opposing dependence of the diffusion constant on water concentration is also displayed in Figure 5. The first result is consistent with observations<sup>1,5</sup> of a concentration dependent diffusion coefficient in various polyurethanes which decreases with increasing water concentration. This behavior can be explained by the clustering

TABLE V

## Permeation and Diffusion Behavior

Polymer	Solubility (g/g)	Bulk Permeability $\frac{\text{g-mil}}{100 \text{ in}^2 \text{ 24 hr}}$	Diffusivity ( $\text{cm}^2/\text{sec} \times 10^7$ )
10PE33	.58	3000	1.49
5PE33	.25	500	.73
3PE33	.08	235	1.24
1PE33	.03	152	2.23
0PE33	.02	108	2.41
5PE28	.40	1030	.84
5PE33	.25	500	.73
5PE40	.15	250	.66

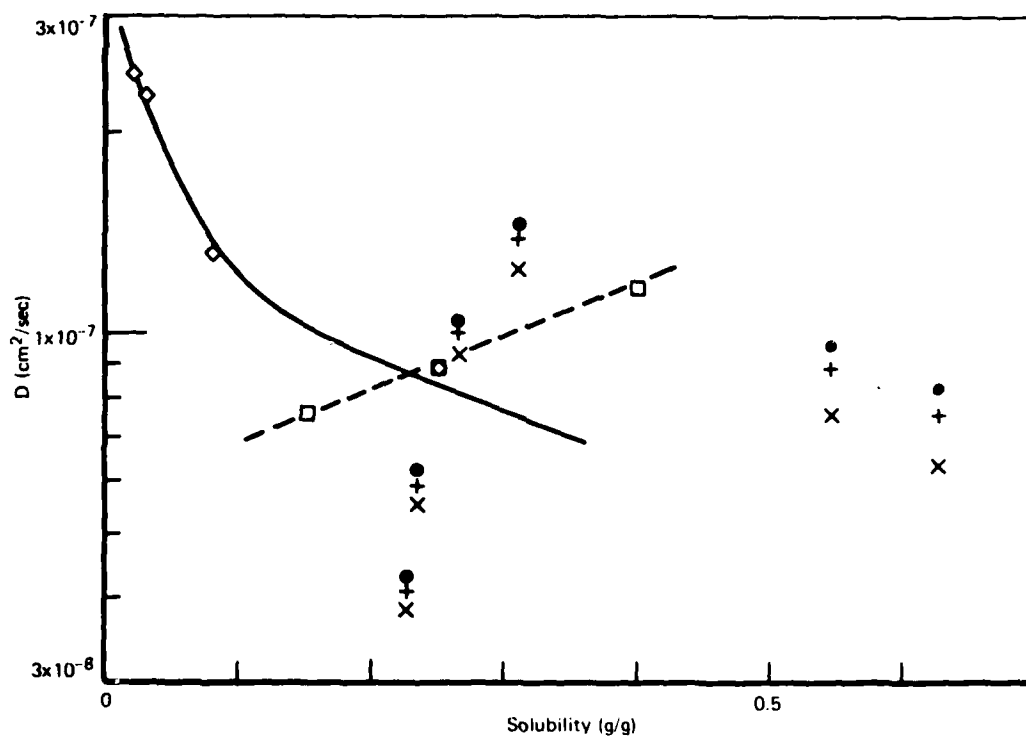

Figure 5. Dependence of diffusion constant on water concentration: ( $\diamond$ ) polymers with soft segment variation, ( $\square$ ) polymers with hard segment variation. Polymers from Tobolsky and co-workers:  $D$  calculated with  $\chi_1 = 0$  ( $\bullet$ ),  $\chi_1 = 0.1$  ( $+$ ), and  $\chi_1 = 0.3$  ( $\times$ ).

of sorbed water leading to a progressive decrease in monomeric water, the effective diffusion species, with increasing water concentration.

In the second series of polymers, the increase in water content is due to a reduction in the hard segment concentration. Although the resulting increase in water uptake may be accompanied by some increase in clustering, apparently the reduced tortuosity of the diffusion path accompanying the reduction in the concentration of the hard segment phase dominates the diffusion behavior. In order to compare our results with those appearing in Table VI of Tobolsky and coworkers<sup>2</sup> it is necessary to calculate diffusion coefficients from their measured values of water flux  $P_w$  in reverse osmosis. If  $P_w$  is interpreted as the product of a diffusion and solubility coefficient, the apparent values of the diffusion coefficient are as high as  $1 \times 10^5$  cm<sup>2</sup>/sec, about 1/3 the value for the self diffusion coefficient of water and nearly two orders of magnitude higher than those obtained on our samples. It has been shown by Paul<sup>5</sup> that the correct procedure involves a correction for a polymer fixed frame of reference and the conversion of the pressure differential to a concentration differential. This leads to the following equation

$$D = \frac{P_w}{V_1} [(1-v_1)^2 (1-2\chi_1 v_1)] \quad (3)$$

where  $V_1$  is the molar volume of water,  $\chi_1$  is the Flory-Huggins interaction parameter and the other terms have been defined previously. The results obtained by this procedure are plotted in Figure 5. Despite the

scatter, it is apparent that the diffusion constants calculated from the reverse osmosis experiment are in the same range of the values which we obtain by steady state transmission.

#### CONCLUSIONS

It is clear from the results of this study that a wide range of water sorption levels and associated transmission rates can be achieved conveniently by appropriate variation of the proportion of polyethyleneoxide and polypropyleneoxide in the block copolymer which comprises the soft segment and by varying the concentration of the hard segment phase. The absence of a direct proportionality between water uptake and PEO content expressed as the ratio of molecules of water to ethylene oxide units indicates that the sorption process under immersion conditions is not simple but is affected by the block copolymer nature of the polyether soft segments. The characteristic decrease in diffusion constant with increasing water uptake in polymers with increasing ethylene oxide content dictates that high water transmission rates are to be achieved only at high swelling ratios. However, some comfort can be taken in the moderate transmission rate obtained in 3PE33 at only 8% water uptake, which is comparable to the water uptake in nylon 6,6. Since a reduction in hard segment concentration has been shown to increase both the water uptake and the diffusion constant, a sample with 28% rather than 33% MDI might very well display a further improvement in transmission at an acceptable water sorption level. The approach used by Tobolsky and

coworkers involving the incorporation of separate polyethylene oxide and polypropylene oxide segments in varying proportions appears to provide polymers with properties similar to those investigated in the present study, in so far as the results obtained under very different conditions can be compared. It would be instructive to analyze the behavior of these polymers by the techniques used in the present study to afford a direct comparison of overall sorption and transmission behavior.

REFERENCES

1. Schneider, N. S., Dusablon, L. V., Snell, E. W. and Prosser, R. A, J. Macromol Sci-Phys B3 623-644 (1969).
2. Chen, C. T., Eaton, R. F., Chang, Y. S. and Tobolsky, A. V., J. Appl. Polym. Sci. 16 2105 (1972).
3. Scholten, H. G., Schuhmann, J. G. and TenHoor, R. E., J. Chem. & Eng. Data, 5 395-400 (1960).
4. Schneider, N. S., Allen, A. L., and Dusablon, L. V., J. Macromol. Sci-phys B3 767-776 (1969).
5. Paul, D. R., J. Polym. Sci., Polymer Phys. Ed., 11, 289 (1973).
6. Barrie, J. A. and Nunn A., This volume & Coatings and Plastics Preprints, 34 489 (1974).

## CHAPTER IV

INTERACTION OF WATER WITH HYDROPHILIC POLYETHER POLYURETHANES:  
SCANNING CALORIMETRIC STUDIES

## ABSTRACT

Scanning calorimetry from 150 to 323° K has been performed on a series of structurally varied polyether polyurethanes in the dry and wet states. One set of polymers used a fixed MDI:butanediol ratio with three different macroglycol compositions; pure poly(ethyleneoxide) (PEO), pure poly(propyleneoxide) (PPO) or 50/50 PEO/PPO block copolymer. The other consisted of a 50/50 PEO/PPO macroglycol at three different mole ratios of MDI:butanediol. The polymer samples with fixed amount of added water were equilibrated at 10° temperature intervals from 273 to 323° K. As equilibration temperatures  $T_{eq}$  were lowered the water melting endotherm diminished in size indicating that more water was bound to the polymer. The polymer soft segment  $T_g$  at the  $T_{eq}$  was close to that of dry polymer but decreased by as much as 40°C with decreasing  $T_{eq}$  in certain samples. It was found that the values of  $T_g$  correlate with the amount of "bound" water estimated from the DSC endotherm rather than with the total amounts of water added to the sample.

## INTRODUCTION

There is continuing interest in elucidating the nature of the interaction between water and hydrophilic polyurethanes as the polymer chemical composition and structure is changed. Of considerable concern is knowledge of the state of water when sorbed by the polymer. Several states can be envisioned: tightly bound to the polymer, transiently bound to the polymer, free monomeric or dimeric species (which are free to diffuse) and either "clustered" or "free" water between chains or in pores. The various types of measurable phenomena are treated as though the water molecules are distributed between the various states. It must be realized, however, that a dynamic equilibrium will exist between water molecules in each of the above specified states as dictated by corresponding exchange rates. Several studies on highly hydrated synthetic and biological polymers have utilized calorimetry to assess states of water in several systems.<sup>1-8</sup> Depending upon the system and water content varying amounts of "crystallizable" water are found, often at melting temperatures below that of pure water. A common interpretation of the data is to assume that water giving rise to a melting endotherm has the same heat of fusion as pure water and thus is a measure of "free" water in the system. The rest is considered to be "bound" to the polymer in one or more states. The present DSC study looks at water interaction in hydrophilic polyurethanes with varying soft segment composition and urethane content. This study is concerned with elucidating the effects of polyurethane composition,

water content, and temperature history on the state of water in the polymer. The evidence concerning the state of water is drawn from observations of the shifts in polyurethane soft segment  $T_g$  and variations in size of the 'melting' endotherm for water.

## EXPERIMENTAL

### Polymers

Several segmented polyether polyurethanes based on MDI, butanediol, and block poly(ethyleneoxide) (PEO)/poly(propyleneoxide) (PPO) soft segments (of general structure as in figure 1) have been synthesized as reported earlier.<sup>9</sup> Table I shows the structure of glycols available (all of molecular weight approximately 2000). Table II summarizes the structure of the polymers used in the present study. The polymer designations are coded as follows. The first number refers to the weight per cent ethylene oxide in the soft segment, PE refers to PEO and the final number refers to the weight per cent MDI in the total polymer: thus 5PE33 is a polymer with 50 weight per cent PEO in the soft segment and 33% MDI by weight in the total polymer.

### Samples

DSC samples were prepared from polymer films cast from DMF solution evaporated under vacuum for 48 hours at 50° C. Dry polymer discs

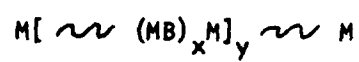

M is MDI

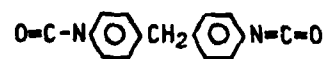

B is Butane diol

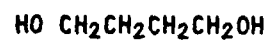

$\sim$  is a macroglycol

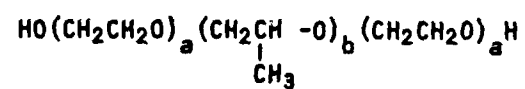

Figure 1. Polyurethane Structures

TABLE I  
VARIATION OF GLYCOL

Glycol	Composition	a	b
C1540	100% PEO	36	0
L35	50/50 PEO/PP0	11	17
P2010	100% PP0	0	35

TABLE II  
POLYMER COMPOSITIONS

Sample	Molar Composition MDI:BD:Polyol	T <sub>g</sub> dry
10PE33	4.20:3:1C1540	242
5PE28	3.15:2:1L35	232
5PE33	4.20:3:1L35	232
5PE40	6.30:5:1L35	240
0PE33	4.20:3:1P2010	233

TABLE III

	T <sub>eq</sub> (°K)					
	273	283	293	303	313	323
t <sub>eq</sub> (hr)	24	20	16	12	8	4

totaling approximately 11 mg were weighed in a tared sample pan and a predetermined amount of water was added by microsyringe. The sample pan was then sealed and reweighed in order to compute the amount of water in the sample. An alternative procedure involved immersing pre-weighed polymer discs in water until saturated, then placing these discs in the tared sample pan on a Perkin Elmer AD-2 microbalance. Weight loss was monitored until the desired weight was reached for a given water content. Following sealing, the pan was again weighed to determine actual water content. The integrity of the hermetic seal was checked by placing the sample in a vacuum oven at 50°C for 1 hour and then reweighing. A weight loss of less than 5 micrograms was accepted as evidence of a good seal.

Two sample pan configurations were used. The standard aluminum Perkin-Elmer volatile sample pans which held approximately 5 mg were used for preliminary work. However, precise addition of water in the small amounts necessary proved very difficult. Therefore the larger diameter sample pans (approximately 10 times greater capacity) designed by F. E. Karasz for use in the DSC-1B were modified for use in the DSC-2. Figure 2 shows these two configurations. During the course of measurements it was found that extensive loss of water occurred by interaction of water with aluminum to form an oxide coating inside the pan. Therefore the sample pans were fashioned from gold foil (5 mil thick). All measurements reported here are from these sample pans.

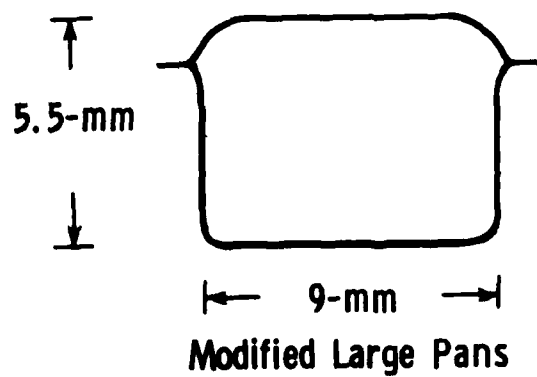
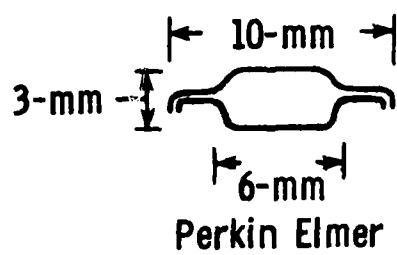

Figure 2. Sample pan configurations.

### Preconditioning

Once prepared, the samples were preconditioned at different temperatures for varying periods of time immediately prior to the scanning in the calorimeter. Times and temperatures are summarized in Table III. Equilibration was done in constant temperature baths or in the DSC-2. An attempt was made to verify that the samples were indeed at equilibrium at a given temperature.

### Scanning Conditions

A Perkin-Elmer DSC-2 equipped with subambient accessory was used. The reservoir was filled with liquid nitrogen bringing the block temperature to approximately 78° K. The system was purged with helium to permit attainment of 150°K and rapid cooling of the sample. The instrument was calibrated on the heating cycle with both cyclohexane and pure water at points within the range from 150° to 300° K. Following conditioning the samples were immediately placed in the DSC-2 which was held at the equilibration temperature. The samples were quenched at 320° per minute to 150°K in order to fix the state of water distribution determined by the equilibration temperature. The samples were then run at 20° per minute to the equilibration temperature, immediately quenched and rescanned. A 2-pen recorder was used to obtain the trace at two sensitivities to avoid attenuation changes in mid-scan with attendant difficulties in determining the baseline.

## RESULTS AND DISCUSSION

The  $T_g$  of the dry polymer has been attributed to the soft segment glass transition and is approximately 25 degrees higher than that of the pure soft segment materials. The  $T_g$  of the isolated soft segments, pure PEO, pure PPO, and symmetric block PEO/PPO/PEO polymers (at this molecular size of 35 to 37 repeat units) all showed a single  $T_g$  at approximately 210°K. The PEO and PPO  $T_g$  are sufficiently close to each other that only a single transition would be expected in the block copolymer. The polymer with the highest hard segment content (5PE40) is raised by 30°. X-ray diffraction measurements and transmission and optical microscopy<sup>10</sup> have shown that these polymers increase in crystallinity and degree of superstructure with increasing hard segment content. This is also supported by our DSC data. These structures could serve as physical crosslinks tying the soft segments down and increasing the  $T_g$ . In addition, since the size of the superstructure is of the order of 5 to 10 microns these regions must include soft segment material. This implies some intermixing of hard and soft segments which would also serve to increase the  $T_g$ . IR data show all NH hydrogen bonded<sup>11</sup> but not all carbonyl so there is the possibility of hard segment hydrogen bonding to the soft segment which would also increase  $T_g$ .

Sorption data on the pure hard segment copolymer (MDI-Bd)<sub>n</sub> has shown that no sorption occurs in this material. The assumption is

therefore made that sorption and interaction of water in these polymers occurs in the soft segment phase and furthermore is affected mainly by the PEO content.

The amounts of water added to the polymer for these experiments was determined from previous immersion data measured as a function of temperature as shown in Figure 3 and Table IV. We chose to use those amounts sorbed at 293° and 323° K. Table V summarizes the amounts added and gives percent water in terms of both total polymer and PEO portion only. Early runs on samples which had remained at room temperature until scanning, showed endotherms (even on low water content polymers.) Further, the  $T_g$  and the area under the endotherms changed from run to run depending upon the temperature history and conditions. This suggested that the water in the polymer is redistributed depending upon the temperature and time allowed at temperature.

Figure 4 shows the  $T_g$  behavior for polymer SPE28 after equilibration at various temperatures. The straight line across Figure 4 is the  $T_g$  of the dry polymer which is not affected by the equilibration temperatures used. Similar behavior is seen in the other polymers containing 50/50 PEO/PP0 blocks as the soft segment. The pure PEO polymer (10PE33) shows much more scatter and larger  $T_g$  depression. There is difficulty in determining the  $T_g$  in this polymer. The  $T_g$  merges with a sharp exotherm assumed to be due to crystallization of some water following the onset of the glass transition in these high

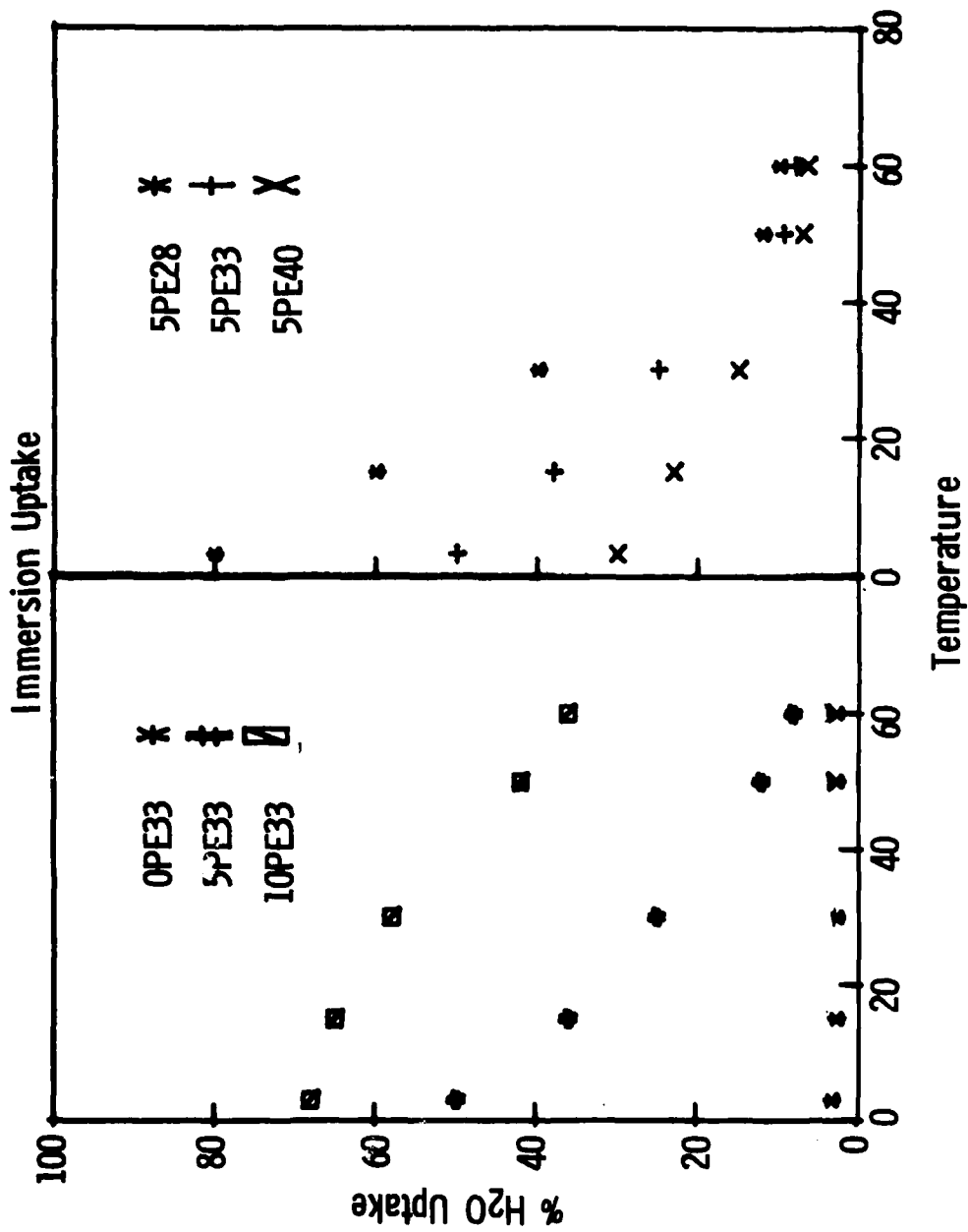

Figure 3 Immersion Uptake

TABLE IV  
IMMERSION UPTAKE\* AT VARIOUS TEMPERATURES

Polymer	T(°K)				
	276	288	303	323	333
10PE33	68	65	58	44	36
SPE33	50	38	25	9.2	8.0
3PE33	32	18	8	5.6	5.2
1PE33	6.0	4.0	3.0	3.6	3.6
OPE33	3.0	2.5	2.0	2.8	2.8
SPE28	80	60	40	12	10
SPE33	50	38	25	9.2	8.0
SPE40	30	23	15	6.7	6.2

\* g/100g polymer

TABLE V  
ADDED WATER

Polymer	Weight dry(mg)	Added H <sub>2</sub> O(mg)	%H <sub>2</sub> O	
			Total Polymer	PEO
OPE33	11.768	0.268	2.2	
SPE28	10.395	1.045	10.1	26.9
	11.059	5.746	52.0	153.9
SPE33	11.744	1.069	9.1	27.6
	11.131	3.676	33.0	110.1
SPE40	11.458	0.799	7.0	25.4
	12.132	2.356	19.4	77.1
10PE33	10.468	4.372	41.8	77.4
	11.506	7.754	67.4	124.8

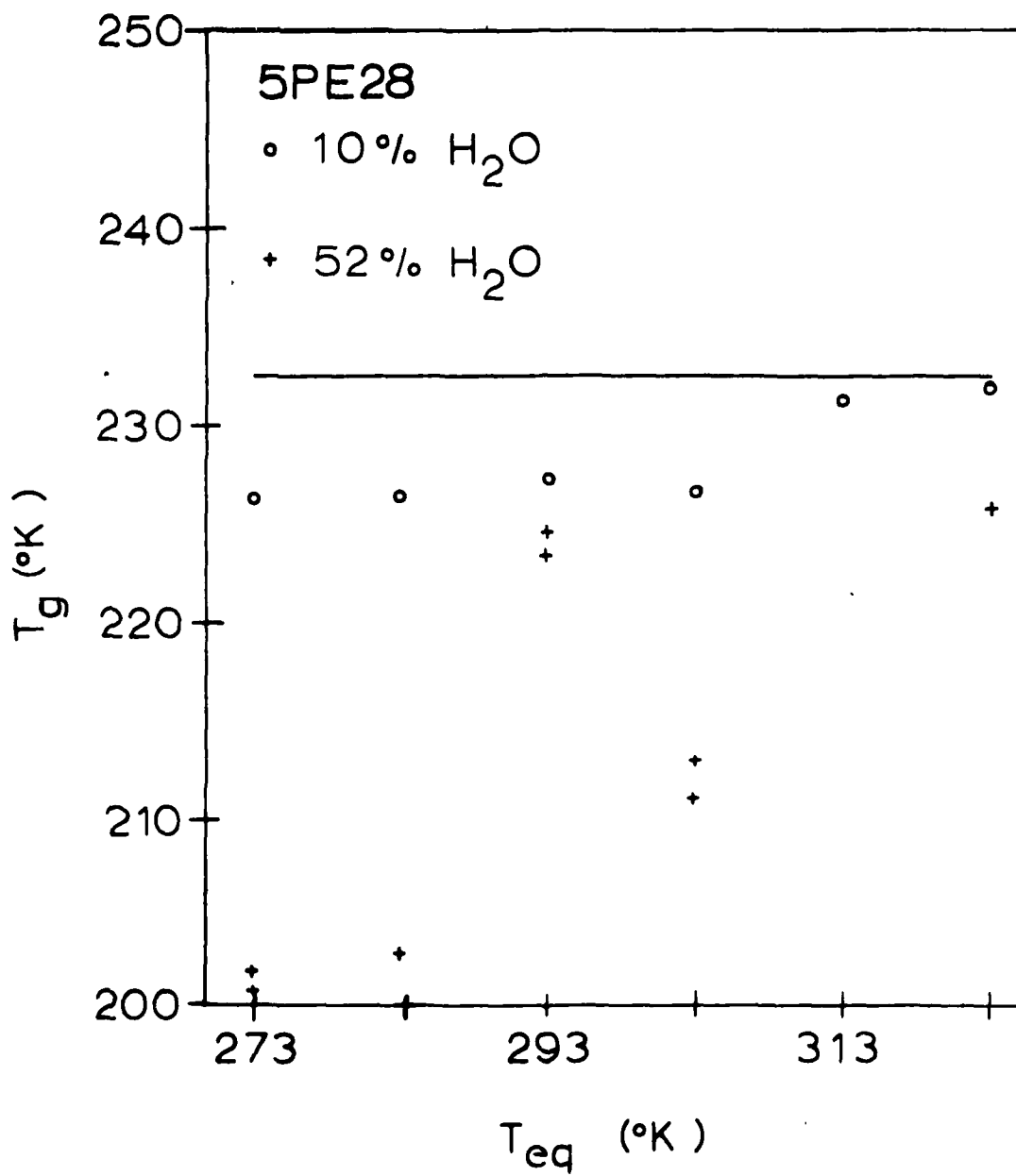

Figure 4  $T_g$  vs  $T_{eq}$  in 5PE28

water content polymers. This also implies redistribution of water with increasing temperatures even in the short times necessary for the scans. Figure 5 shows the effect of water on the glass transition in OPE33, the polymer with pure PPO soft segment. In this polymer an antiplasticizing effect occurs as indicated by an increase of the  $T_g$ .

Figure 6 shows the water represented by the area under the endotherm. We assume water giving rise to this transition has  $\Delta H_f$  equal to 79.8 calories per gram. It is obvious that at the lower temperature of equilibration there is less water free to melt. Concomitantly, there is a greater effect upon the glass transition of the soft segment. Figure 6 shows an anomalous point at  $T_{eq}$  of 293°K. This sample was equilibrated in the DSC under helium purge and 78°K block temperature rather than the thermostatted bath. The heat source is at the bottom of the sample. Under these conditions there is probably a temperature gradient of which we have no exact knowledge. Thus,  $T_{eq}$  for these conditions is not defined. Even so, note that the presence of the larger endotherm is accompanied by a smaller  $T_g$  depression.

Melting temperatures are not reported because the endotherms are very broad. Also the apparent "free" water melts at temperatures greater than 273° K. This is certainly an artifact, probably due to the previously mentioned temperature gradient across the cell. The heat transfer properties through the polymer are also unknown. It would seem reasonable to assume that the area under this endotherm

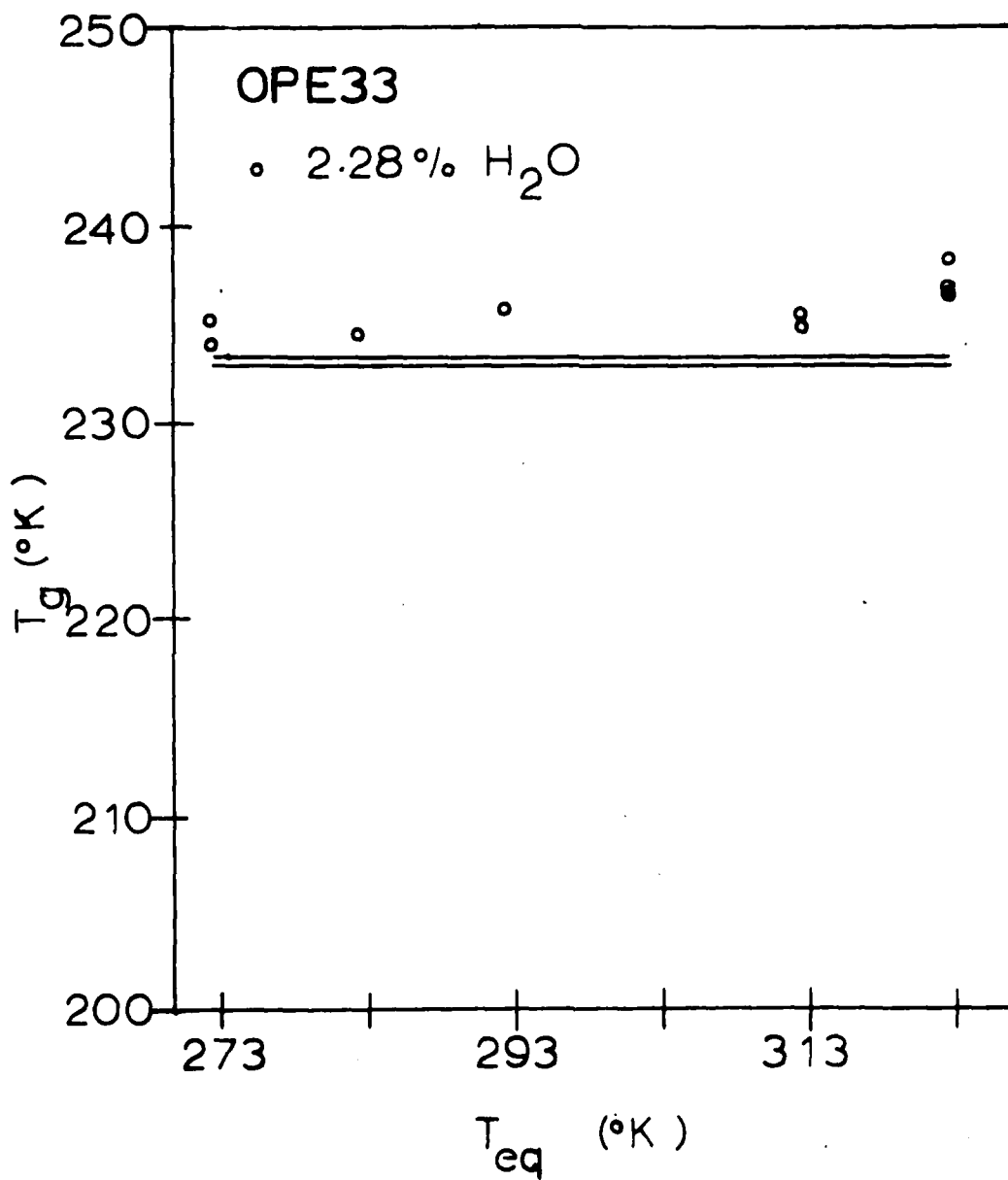

Figure 5  $T_g$  vs  $T_{eq}$  In OPE33

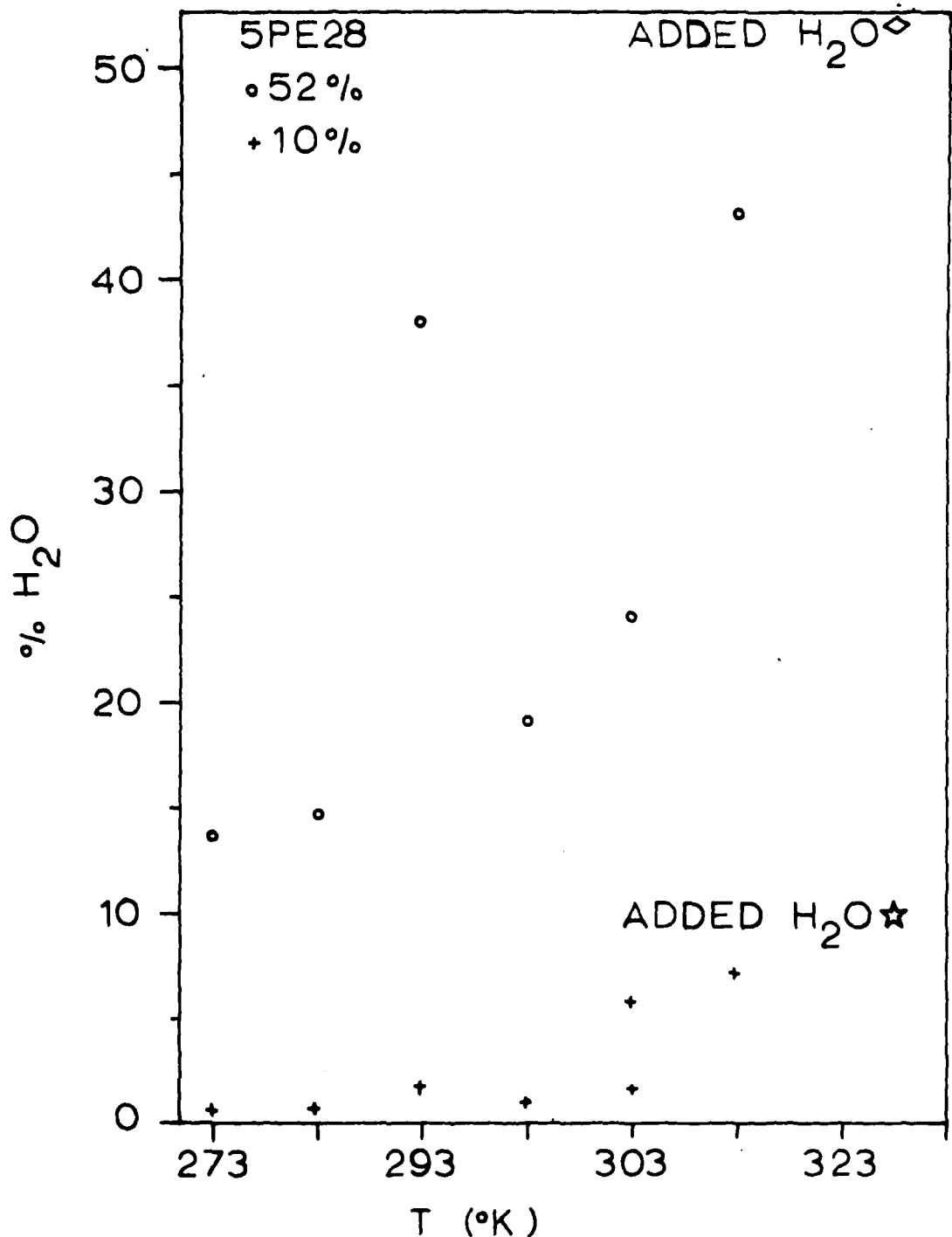

Figure 6 Endothermic Water vs T<sub>eq</sub> In SPE28

is a valid measure of water behaving as "bulk" water with the heat of fusion of pure water. Subtraction of the amount of water so calculated from the amount of water added is a measure of the water "bound" to the polymer. Figure 7 plots and Table VI shows the percent water "bound" in the polymer versus  $\Delta T_g$  [ $T_g$  (wet) -  $T_g$  (dry)] for the polymers with 50/50 PEO/PP0 soft segment. The water content is calculated assuming constant small sorption on the PP0 block which is subtracted before normalizing to the PEO content. Points for 5PE33 and 5PE28 fall around the same straight line while those for 5PE40 fall on a different line showing greater displacement of  $T_g$  for a given amount of water in the PEO portion of the polymer. This may be due to the water interacting with more PEO on soft segments which are incorporated into the fibrillar structure of the polymer. In 5PE40 this structure is interpenetrating versus more isolated spherulites in 5PE28 and 5PE33 (see micrographs of Figure 8). Thus there would be a greater affect on the glass transition by loosening "physical" crosslinks than if the water were involved largely in the amorphous state. There may also be competition of water for hydrogen bonds to the soft segment which should show a greater affect on  $T_g$ .

Figure 9 is a similar plot for the polymer with the same MDI-Bd content and variation in soft segment composition. The line through the points from 5PE33 continues through those from 0PE33 while those points from 10PE33 show much more displacement in  $T_g$  for a given amount of water on the PEO. The polymers all have similar spherulitic

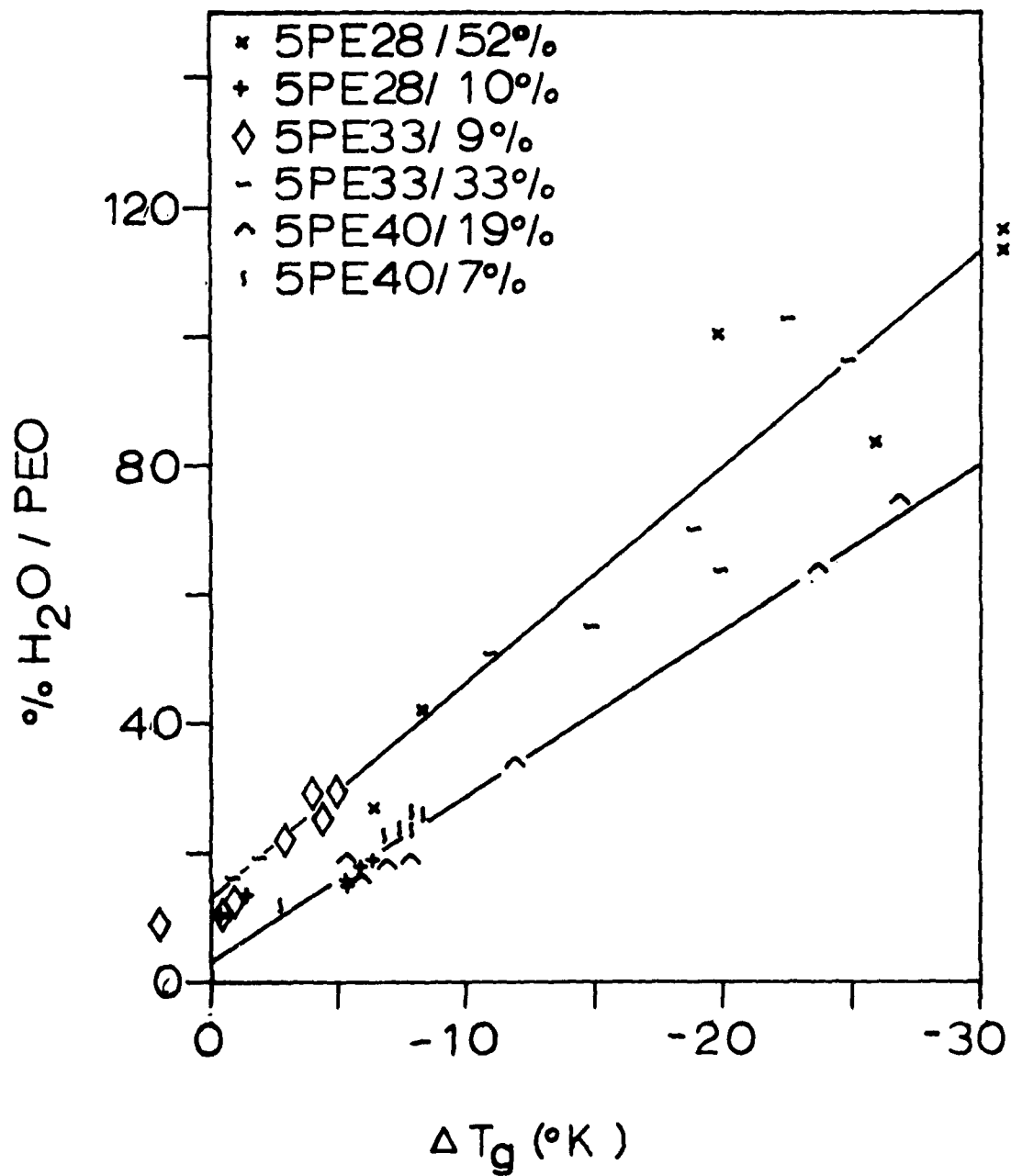

Figure 7 "Bound" Water vs  $\Delta T_g$  (Hard Segment Variation)

TABLE VI

 $\Delta T_g$  AND %H<sub>2</sub>O WATER ON PEO

SAMPLE	$T_{eq}$ ( $^{\circ}$ K)											
	273	283	293	303	313	323	$\Delta T_g$	%H <sub>2</sub> O	$\Delta T_g$	%H <sub>2</sub> O	$\Delta T_g$	%H <sub>2</sub> O
OPE33 2.3%	+1.3	3.5	+1.2	3.4	+2.4	2.6	+2.3	2.8	+2.8	2.8	+3.8	2.4
5PE33 9%	-6.4	29	-4.8	29	-4.0	29	-4.2	26	-0.6	11	+2.6	10
5PE33 33%	-24	104	-25	97	-19	65	-18	70	-2.0	19	-0.7	16
10PE33 42%	-49	55	-46	46	-48	51	-50	50	-48	48	-34	39
10PE33 67%	-38	62	-38	52	-36	54	-38	57	-38	50	-20	19
5PE40 7%	-8.1	27	-8.5	26	-8.3	24	-7.6	24	-8.0	24	-2.4	12
5PE40 19%	-27	75	-27	74	-24	64	-8.0	20	-12	34	-5.5	19
5PE28 10%	-6.2	30	-6.1	30	-5.3	26	-6.0	28	-5.1	26	-0.5	10
5PE28 52%	-31	117	-31	113	-8.6	41	-21	100	-26	83	-6.7	27

( ) values are for samples equilibrated in the DSC-2



5PE28

5PE33

5PE40

TRANSMISSION ELECTRON MICROGRAPHS  
POLYURETHANE ELASTOMERS

Figure 8 Transmission Electron Micrographs 5PE28, 5PE33, 5PE40

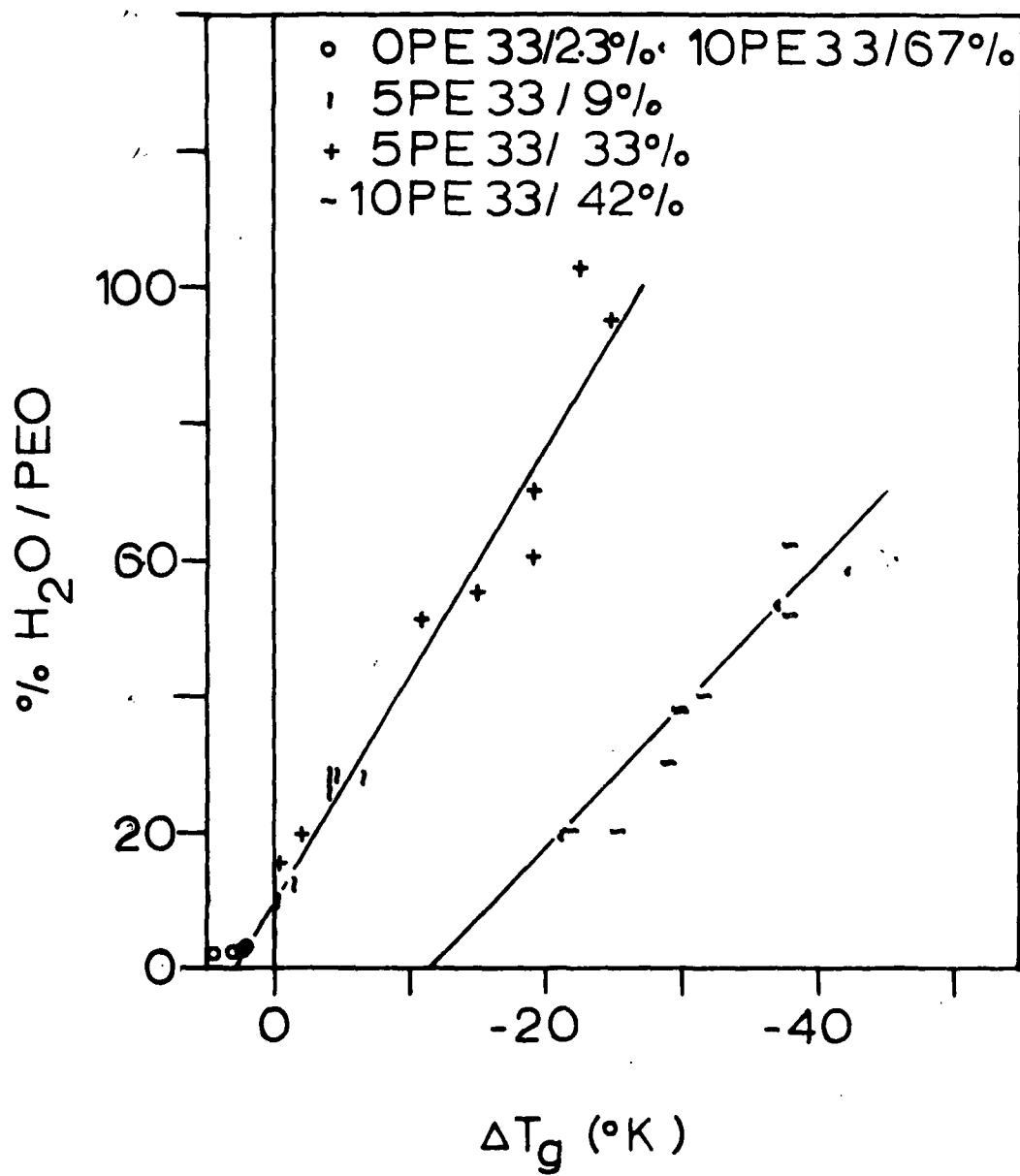

Figure 9 "Bound" Water vs  $\Delta T_g$  (Soft Segment Variation)

texture as seen in Figure 10. The pure PPO polymer shows a small increase in  $T_g$  with water content. This would suggest that the water hinders the motion in these segments possibly by interchain hydrogen bridging. The presence of central PPO blocks in the soft segment of SPE33 may lead to incomplete miscibility among the blocks of the soft segments, constraining the mobility of the PEO portion. In IOPE33 there is no such constraint, thus the effect of water on the segmental motion and therefore the glass transition is more marked.

Except for IOPE33 where the data does not allow extrapolation to  $\Delta T_g = 0$ , we note that the intercept shows a finite amount of water in the polymer. This would indicate that some of the non freezing water is not interacting with the polymer and may be present as monomeric or dimeric species which are too small to 'melt'.

Diluent depression of  $T_g$  is often rationalized in terms of free volume theory. Following Meares<sup>12</sup> the depressed  $T_g$  may be calculated by

$$T_g = \frac{v_p T_{gp} (\alpha_l - \alpha_g) + v_d T_{gd} \alpha_d}{v_p (\alpha_l - \alpha_g) + v_d \alpha_d}$$

where:

$T_g$  is the depressed glass transition temperature,

$T_{gp}$ ,  $T_{gd}$  are glass transition temperatures of polymer and diluent respectively,

$v_p$ ,  $v_d$  are volume fractions of polymer and diluent respectively,

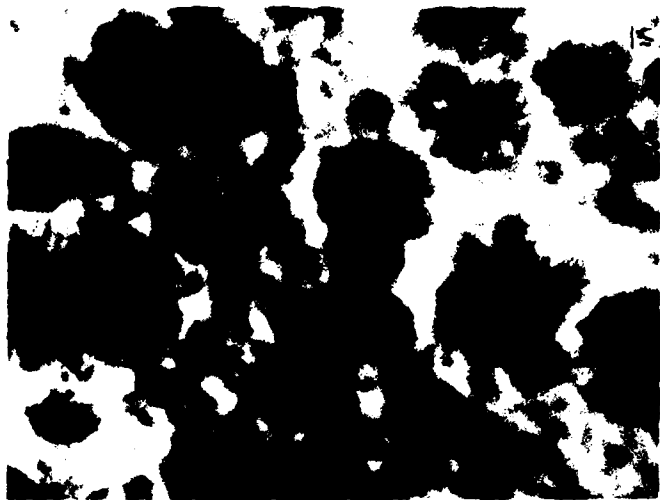

OPE33

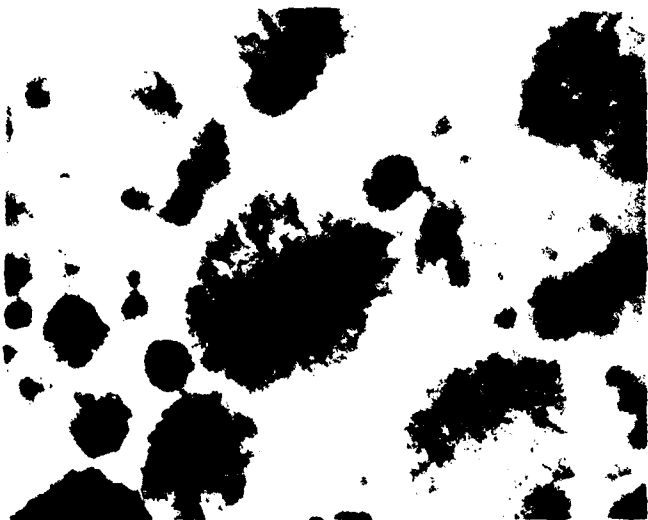

5PE33



10PE33

TRANSMISSION ELECTRON MICROGRAPHS  
POLYURETHANE ELASTOMERS

Figure 10 Transmission Electron Micrographs OPE33, 5PE33, 10PE33

$(\alpha_l - \alpha_g)$  is the difference in expansion coefficients of polymer in glass and liquid,

$\alpha_d$  is the expansion coefficient of diluent.

Table VII gives values of calculated and measured  $T_g$  at several volume fractions of water for these polymers. These values were calculated assuming  $(\alpha_l - \alpha_g)$  is  $4.8 \times 10^{-4}$  (see reference 13)  $\alpha_d = 2.07 \times 10^{-4}$  (see reference 14) and  $T_{gd}$  equals  $137^\circ\text{K}^{15}$ . Figure 11 is a plot of  $\Delta T_g$  measured versus  $\Delta T_g$  calculated. The line is that which obtains if theory holds. The measured values for the PEO/PP0 block copolymer soft segment polymers fall near the theoretical line around another line of the same slope but showing smaller  $T_g$  than calculated. This substantiates the earlier implications that not all of the "bound" water is tied to the polymer and that some is probably present as monomeric and dimeric species. In the PP0 polymer the antiplasticizing effects are not in agreement with theory and must be attributed to specific local immobilizing interactions rather than free volume effects. The opposite deviation for 10PE33 implies that interactions in addition to free volume effects are operative when no PP0 block is present.

TABLE VII

T<sub>g</sub> MEASURED AND T<sub>g</sub> CALCULATED FROM DILUENT DEPRESSIONT<sub>eq</sub> (°K)

SAMPLE	273		283		293		303		313		323	
	T <sub>g</sub> calc	T <sub>g</sub> meas	T <sub>g</sub> calc	T <sub>g</sub> meas	T <sub>g</sub> calc	T <sub>g</sub> meas	T <sub>g</sub> calc	T <sub>g</sub> meas	T <sub>g</sub> calc	T <sub>g</sub> meas	T <sub>g</sub> calc	T <sub>g</sub> meas
OPE33	231.7	234.5	231.8	234.4	232.1	235.6	232.0	235.4	232.0	236.0	232.2	237.0
5PE33 9%	221.7	226.1	221.7	227.7	221.8	228.5	222.8	228.8	228.3	231.9	228.6	235.1
5PE33 33%	202.5	210.3	203.8	207.5	211.2	213.0	209.9	214.1	225.2	230.5	226.3	231.8
10PE33 42%	221.8	193.8	224.7	196.5	223.2	194.4	223.5	191.6	224.2	194.7	226.9	208.2
10PE33 67%	219.8	204.6	222.8	204.5	221.1	206.0	221.2	204.1	223.3	203.9	234.2	222.0
5PE40 7%	229.1	231.9	229.1	231.5	230.0	231.7	230.1	232.4	232.0	230.1	234.9	237.6
5PE40 19%	214.2	212.8	214.6	213.3	217.2	215.9	231.7	232.0	226.5	228.3	231.9	234.5
5PE28 10%	221.6	226.3	221.5	226.4	222.5	227.2	221.9	226.5	222.5	227.4	228.4	232.0
5PE28 52%	199.9	201.3	200.6	201.5	217.7	223.9	203.0	211.9	206.7	206.7	222.3	225.8

$(\alpha_l - \alpha_g)$  is the difference in expansion coefficients of polymer in glass and liquid,

$\alpha_d$  is the expansion coefficient of diluent.

Table VII gives values of calculated and measured  $T_g$  at several volume fractions of water for these polymers. These values were calculated assuming  $(\alpha_l - \alpha_g)$  is  $4.8 \times 10^{-4}$  (see reference 13)  $\alpha_d = 2.07 \times 10^{-4}$  (see reference 14) and  $T_{gd}$  equals  $137^\circ\text{K}^{15}$ . Figure 11 is a plot of  $\Delta T_g$  measured versus  $\Delta T_g$  calculated. The line is that which obtains if theory holds. The measured values for the PEO/PP0 block copolymer soft segment polymers fall near the theoretical line around another line of the same slope but showing smaller  $T_g$  than calculated. This substantiates the earlier implications that not all of the "bound" water is tied to the polymer and that some is probably present as monomeric and dimeric species. In the PP0 polymer the antiplasticizing effects are not in agreement with theory and must be attributed to specific local immobilizing interactions rather than free volume effects. The opposite deviation for 10PE33 implies that interactions in addition to free volume effects are operative when no PP0 block is present.

TABLE VII

$T_g$  MEASURED AND  $T_g$  CALCULATED FROM DILUENT DEPRESSION  
 $T_{eq}$  ( $^{\circ}$ K)

SAMPLE	273		283		293		303		313		323	
	$T_g$ calc	$T_g$ meas	$T_g$ calc	$T_g$ meas	$T_g$ calc	$T_g$ meas	$T_g$ calc	$T_g$ meas	$T_g$ calc	$T_g$ meas	$T_g$ calc	$T_g$ meas
0PE33	231.7	234.5	231.8	234.4	232.1	235.6	232.0	235.4	232.0	236.0	232.2	237.0
5PE33 9%	221.7	226.1	221.7	227.7	221.8	228.5	222.8	228.8	228.3	231.9	228.6	235.1
5PE33 33%	202.5	210.3	203.8	207.5	211.2	213.0	209.9	214.1	225.2	230.5	226.3	231.8
10PE33 42%	221.8	193.8	224.7	196.5	223.2	194.4	223.5	191.6	224.2	194.7	226.9	208.2
10PE33 67%	219.8	204.6	222.8	204.5	221.1	206.0	221.2	204.1	223.3	203.9	234.2	222.0
5PE40 7%	229.1	231.9	229.1	231.5	230.0	231.7	230.1	232.4	232.0	230.1	234.9	237.6
5PE40 19%	214.2	212.8	214.6	213.3	217.2	215.9	231.7	232.0	226.5	228.3	231.9	234.5
5PE28 10%	221.6	226.3	221.5	226.4	222.5	227.2	221.9	226.5	222.5	227.4	228.4	232.0
5PE28 52%	199.9	201.2	200.6	201.5	217.7	223.9	203.0	211.9	206.7	206.7	222.3	225.8

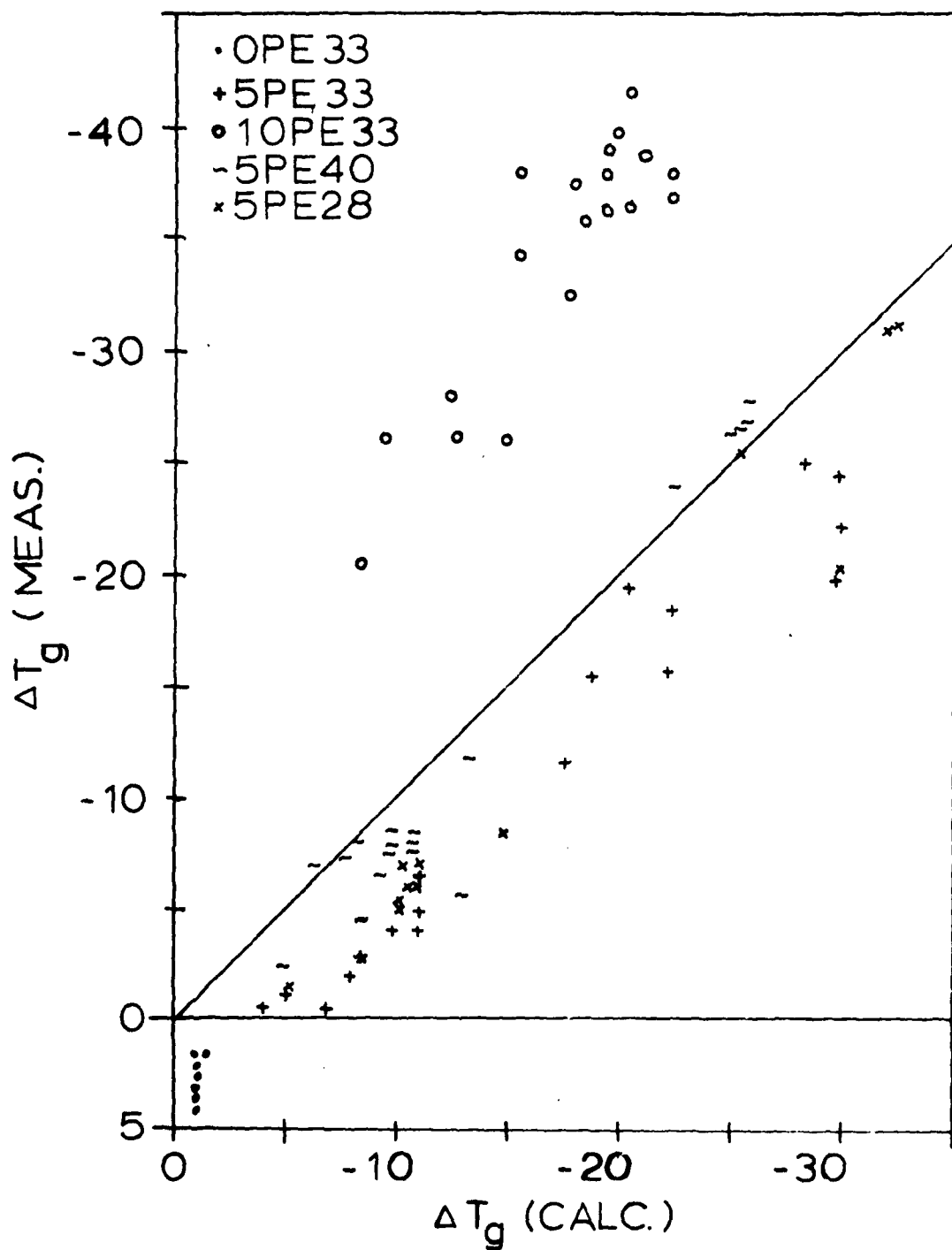

Figure 11  $\Delta T_g$  measured vs  $\Delta T_g$  calculated

## REFERENCES

1. Haly, A. R. and Snaith J. W., Biopolymer 6 1355 (1968) and Biopolymer 7, 459 (1969).
2. Haly, A. R. and Snaith J. W., Biopolymer 10 1681 (1971).
3. Haly, A. R. and Snaith, J. W., Textile Res. J. 907 October (1967).
4. Kunz, I. Q., and Kauzmann, W. Advances in Protein Chemistry, 28 239 (1974).
5. LeMoigne, J., and Gramain, Ph. European Polym. J., 10, 401, (1974).
6. Yasuda, H., Olf, H. G., Crist, B., Lamaze, C. E. and Peterlini, A., Preprint No 313. Research Triangle Institute, 1971.
7. Lee, H. B., Jhon, M. S., and Andrade, J. D., J. Coll and Interface Sci. 51, 225 (1975).
8. Frommer, M. A., and Shporer, M. Org, Coat & Plast, Prep. 32 #1 1972.
9. Illinger, J. L., Schneider, N. S. and Karasz, F. E., in "Permeability of Plastic Films to Gases, Vapors and Liquids", Hopfenberg, H. B., ed, Plenum Press, New York (1975) p 183.
10. Schneider, N. S., Desper, C. R., Illinger, J. L., King, A. O., and Barr, D. B., J. Macromol Sci-Phys, B11, 527 (1975).
11. Sung, C. P. K. and Schneider, N. S., Macromolecules, 8, 68 (1975).
12. See development and references from Meares, "Polymers Structure and Bulk Properties", Van Nostr and Co. (1965) Chap 10.
13. Williams, M. L., Landel, R. F., and Ferry, J. D., J. Amer. Chem. Soc. 77, 3701 (1955).
14. CRC Handbook of Chemistry and Physics.
15. Rasmussen, D. H. and MacKenzie, A. P., J. Phys. Chem., 75 967 (1971).

## CHAPTER V

INTERACTION OF WATER WITH HYDROPHILIC POLYETHER POLYURETHANES:  
SORPTION AND DIFFUSION STUDIES\*

## ABSTRACT

Polyether polyurethanes based on MDI, butanediol and block poly(ethyleneoxide) poly(propyleneoxide) show large increases in sorption with decreasing temperature. The heats of sorption are negative and change with changing ethylene oxide content in the soft segment. They are unaffected by changes in hard segment content. The diffusion coefficient for water through these polymers decreases with increasing water concentration in the polymer and with decreasing temperature. Ethyleneoxide content and hard segment content also affect concentration dependence of  $D$ . Cluster function, size, and number show very different behavior with water concentration from the pure propylene oxide soft segment polymer through block copolymer soft segment polymers to the pure ethylene oxide soft segment polymers.

\* Presented in part at the First Chemical Congress of the North American Continent, Mexico City, Mexico, December 1975.

## INTRODUCTION

Interest in hydrophilic polymers for biomedical applications, packaging and high moisture transmitting fabric coating continues. A previous publication<sup>1</sup> has shown that structural variations in polyether polyurethanes incorporating varying extent of hydrophilic character in the soft segment affects sorption levels and water transmission rates. The present study extends the sorption measurements to a range of temperatures and the transmission measurements to additional upstream humidities. We are also concerned with more detailed data analysis. Correlation with current theories<sup>2-9</sup> have been carried out to elucidate the nature of the water-polymer interaction, particularly in regard to concentration dependence of diffusion coefficients and relative amounts of clustered water.

## EXPERIMENTAL

### Polymers

Segmented polyether polyurethanes as reported in previous work<sup>1</sup> were used for this study. The general structure is shown in Figure 1. The available macroglycols are summarized in Table I and the structure of the polymers in Table II. Films used for all measurements were cast from DMF solution, evaporated at 50°C for 48 hours under vacuum. These films were approximately 8 mils in thickness.

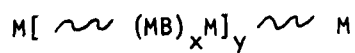

M is MDI

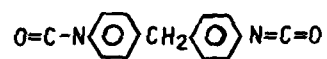

B is Butane diol

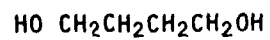

$\sim$  is a macroglycol

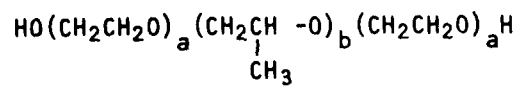

Figure 1. Polyurethane Structures

TABLE I  
VARIATION OF GLYCOL

Glycol	Composition	a	b
C1540	100% PEO	36	0
L35	50/50 PEO/PPO	11	17
L43	70/30 PEO/PPO	7	23
L61	90/10 PEO/PPO	2.5	33
P2010	100% PPO	0	35

TABLE II  
POLYMER COMPOSITIONS

Polymer	Molar Composition MDI:Bd:Polyol
10PE33	4.20:3:1C1540
5PE40	6.30:5:1L35
5PE33	4.20:3:1L35
5PE28	3.15:2:1L35
3PE33	4.20:3:1L43
1PE33	4.20:3:1L61
0PE33	4.20:3:1P2010

### Sorption Measurements

Equilibrium sorption measurements were performed in the manner reported previously<sup>1</sup> at temperatures of 276, 288, 303, 323, and 333° K.

Sorption isotherms were measured in the thermostated vacuum system described previously except for one modification. The sample hang down tube was surrounded by a constant temperature bath at the temperature of interest (288, 303, or 323° K) while the cabinet was maintained at least 5°C higher to assure reaching saturation pressure of water in sample chamber. The Perkin-Elmer AR-1 recording microbalance was recalibrated at each cabinet temperature.

### Transmission Measurements

Steady state transmission measurements with liquid in contact with the membrane were again measured using cup cells with the Aminco Aire cabinet adjusted to temperatures of 288° and 323° K at 50% RH. Evaporation rates at these new conditions were also measured, as had been done with the previous 30° temperature.

Additional transmission values with varying upstream humidity were obtained at 303 and 323° K using a Modern Controls IRD Diffusometer. This instrument detects the build up of water concentration in the dry down stream chamber by means of an infrared beam and a detector of

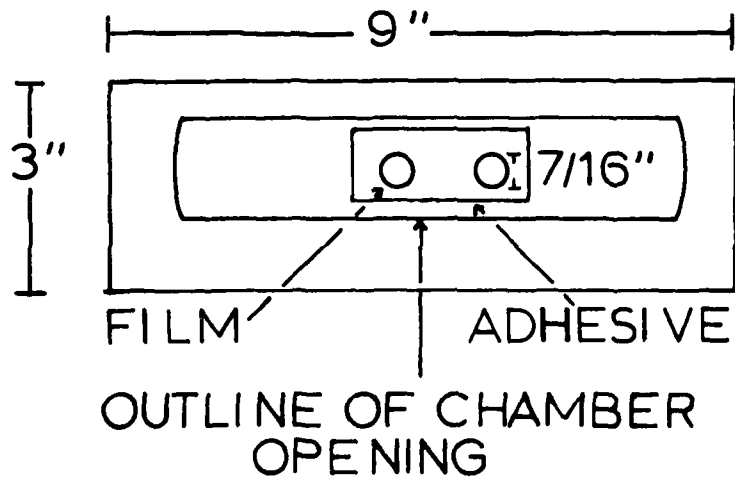

Figure 2 Mask for High MVTR Polymers

narrow band width centered at the water infrared absorption (See ref 10 for chamber configuration). The time necessary to build up a small concentration (less than one percent) of water is measured, the chamber is then swept dry and the measurement automatically repeated until a constant interval is reached. This indicates that steady state permeation has been attained. The instrument constant, R, was determined on a film of known water vapor transmission rate. Due to the extreme sensitivity of the instrument, and the high transmission rates of these polymers, a mask of adhesive backed aluminum foil was devised to decrease the film area from 18 in. to approximately 2 cm<sup>2</sup> as seen in Figure 2. The MVTR was then calculated from the relation

$$\text{MVTR} = \frac{R}{t(\text{sec})} \times \frac{18 \text{ in}^2}{A \text{ in}^2}$$

## RESULTS AND DISCUSSION

### Sorption Behavior

#### Isotherms

Figures 3, 4 and 5 show the isotherms for 10PE33, 5PE33 and 0PE33 respectively at different temperatures. These sorption isotherms appear to be surprisingly simple, showing a linear region at low water vapor activity with rapidly increasing sorption at high activity. In the two PEO containing polymers sorption levels increase with decreasing temperature, the changes being most marked at  $p/p_0$  above 0.8. The

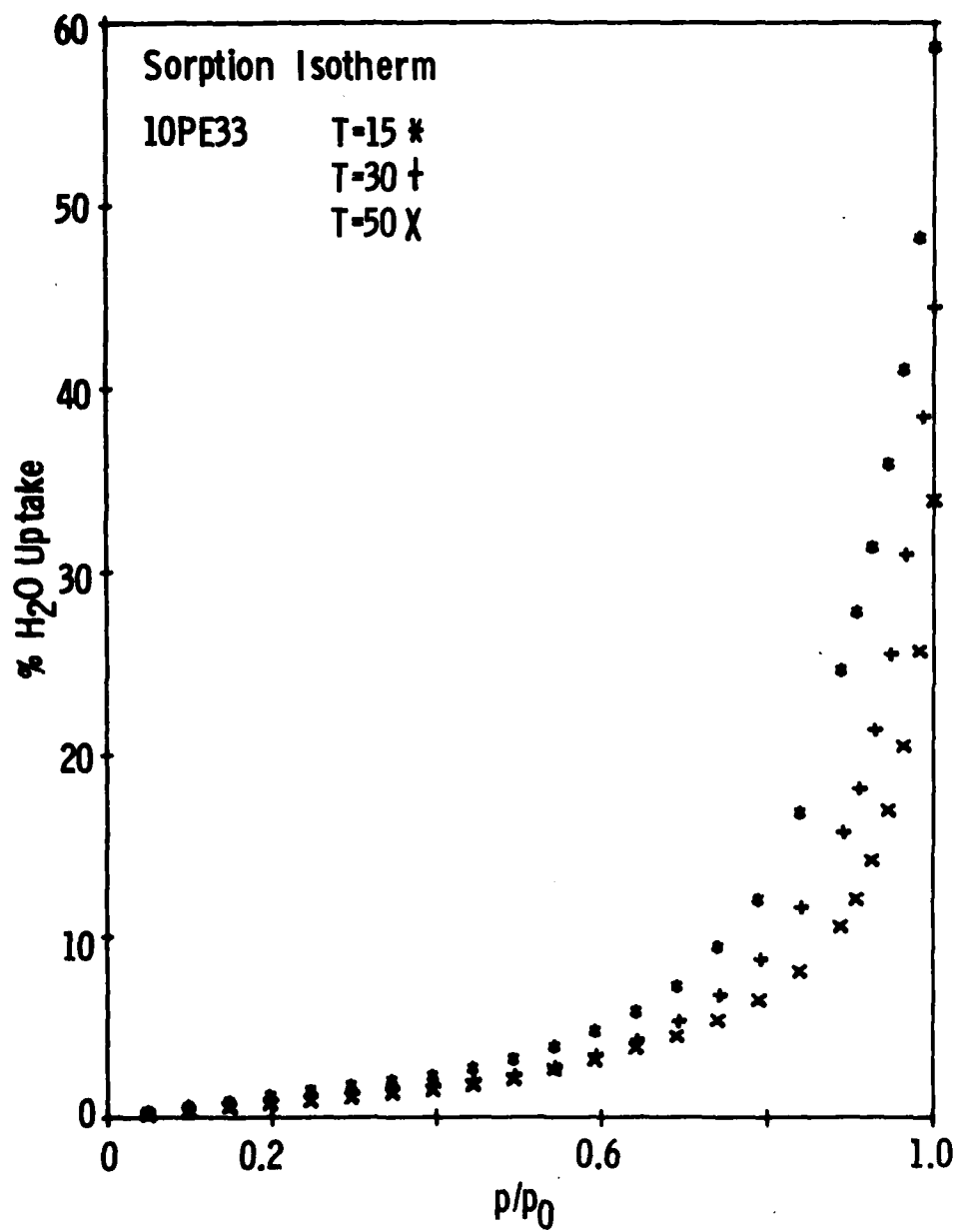

Figure 3 Sorption Isotherms 10PE33 T=15, 30, 50

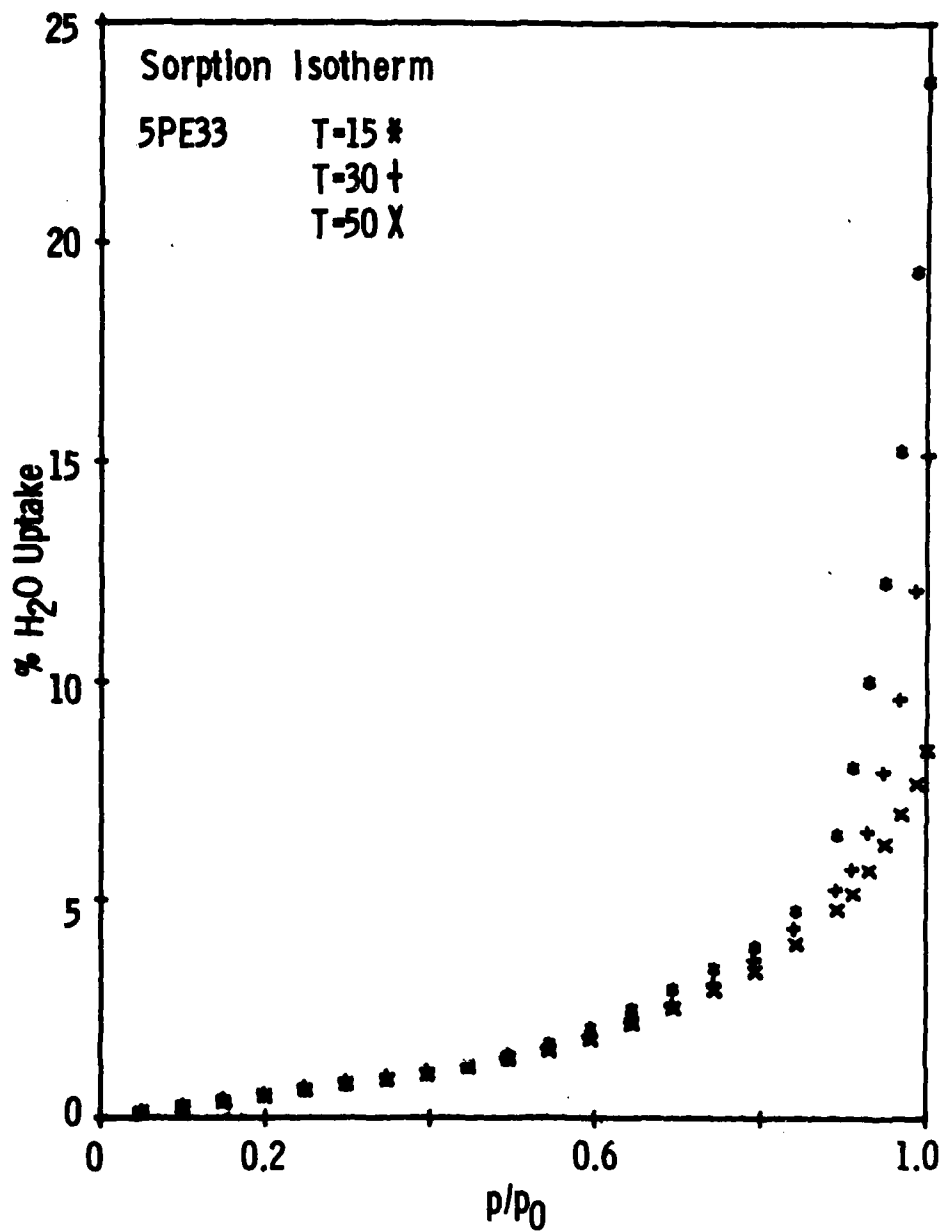

Figure 4 Sorption Isotherms 5PE33 T=15, 30, 50



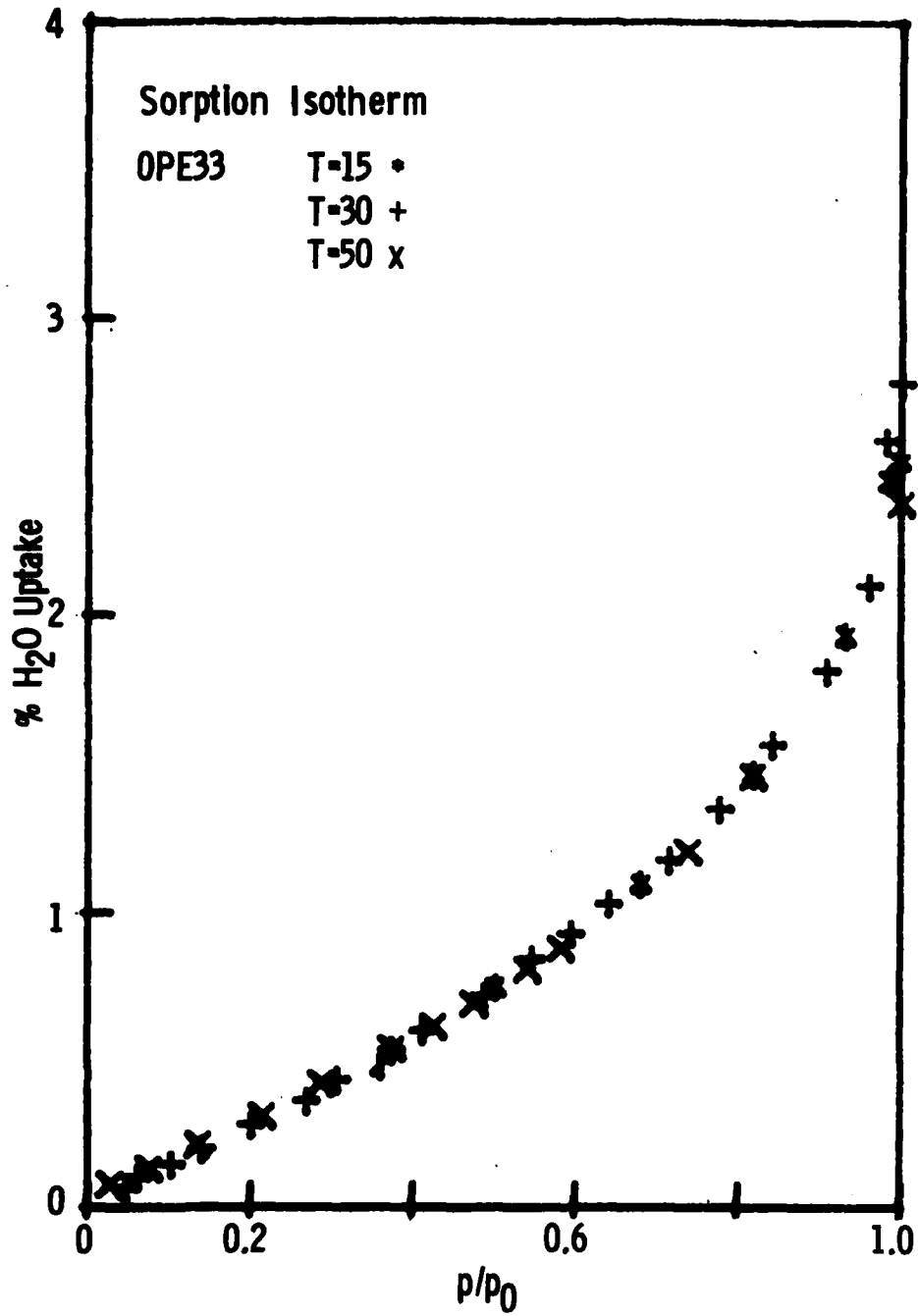

Figure 5 Sorption Isotherms OPE33 T=15, 30, 50

polymer with the pure PPO soft segment (OPE33), differs in that the isotherms are superposable at all temperatures. The changes in sorption behavior with composition are illustrated by Figure 6 and 7 where sorption is plotted as molecules of  $H_2O$  per EO unit. Figure 6 compares isotherms at  $30^\circ C.$ , for polymers varying over the full range of relative PPO/PEO composition at fixed hard segment content. The isotherms for the three samples with block copolymer soft segments are virtually superimposable to  $p/p_0$  of 0.8 while 10PE33 shows progressively higher sorption levels starting at  $p/p_0$  of 0.5. These isotherms, as well as those at  $50^\circ C.$  which are not shown, display increasing sorption with increasing PEO in the soft segment. However, as Figure 6 shows, when considered on the basis of molecules of water per ethyleneoxide unit, the increase is not proportional to the PEO content and the deviations are greatest at high activity.

Figure 7 compares isotherms for three polymers of different hard segment content but fixed 50/50 PEO/PPO soft segment content. The isotherms plotted on the basis of molecules  $H_2O$  per EO unit again are virtually superimposable to  $p/p_0$  of 0.8. Although the per cent water uptake decreases with increasing hard segment content the isotherms as presented in Figure 7 do not preserve this relation since the curve for 5PE33 lies below that for 5PE40.

The linear portions of the isotherms for the various polymers have been fit by least squares regression to a Henry's law relation up to an activity of  $p/p_0$  equals 0.4 with correlation coefficients greater than

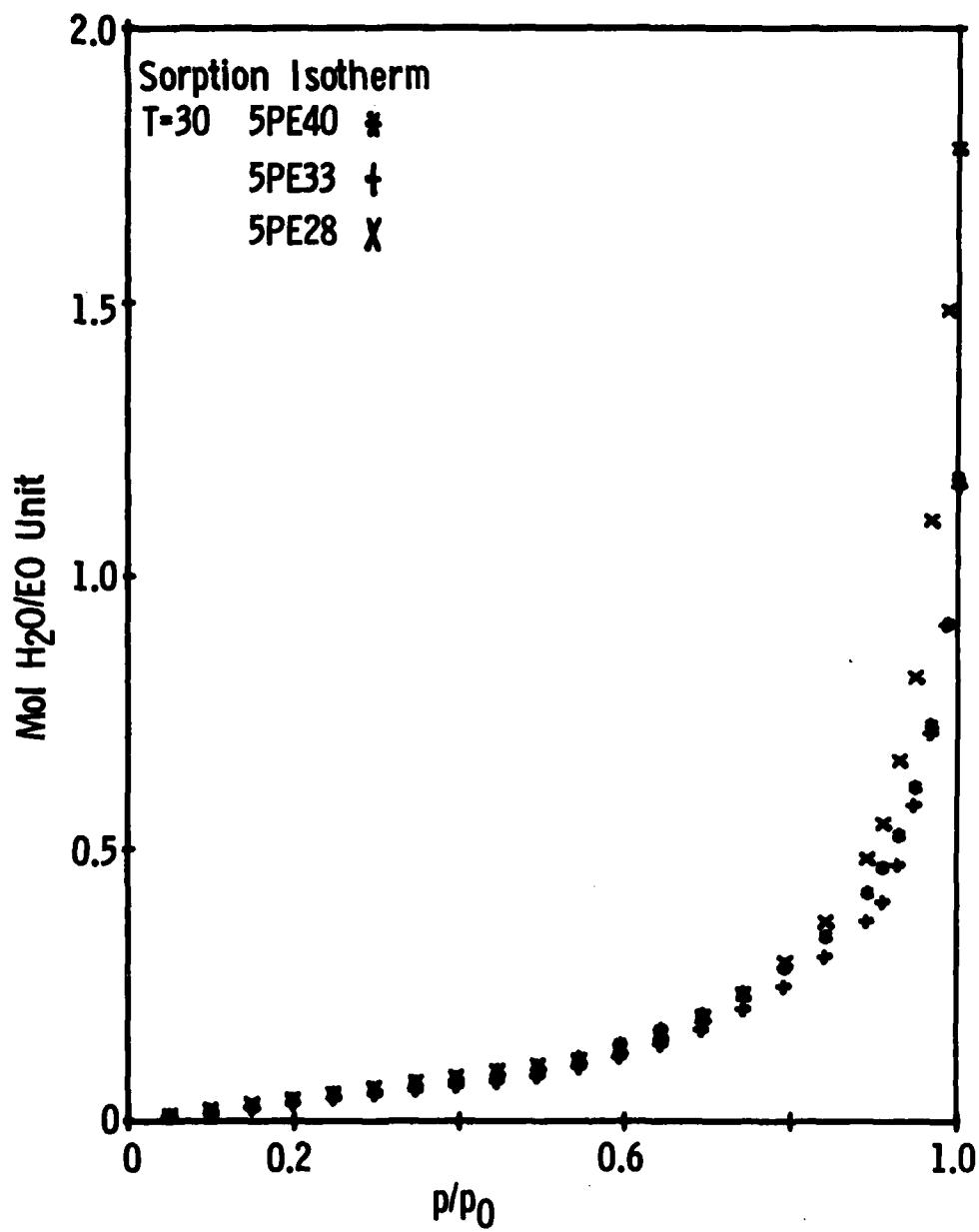

Figure 6 Sorption Isotherms, Soft Segment Variation

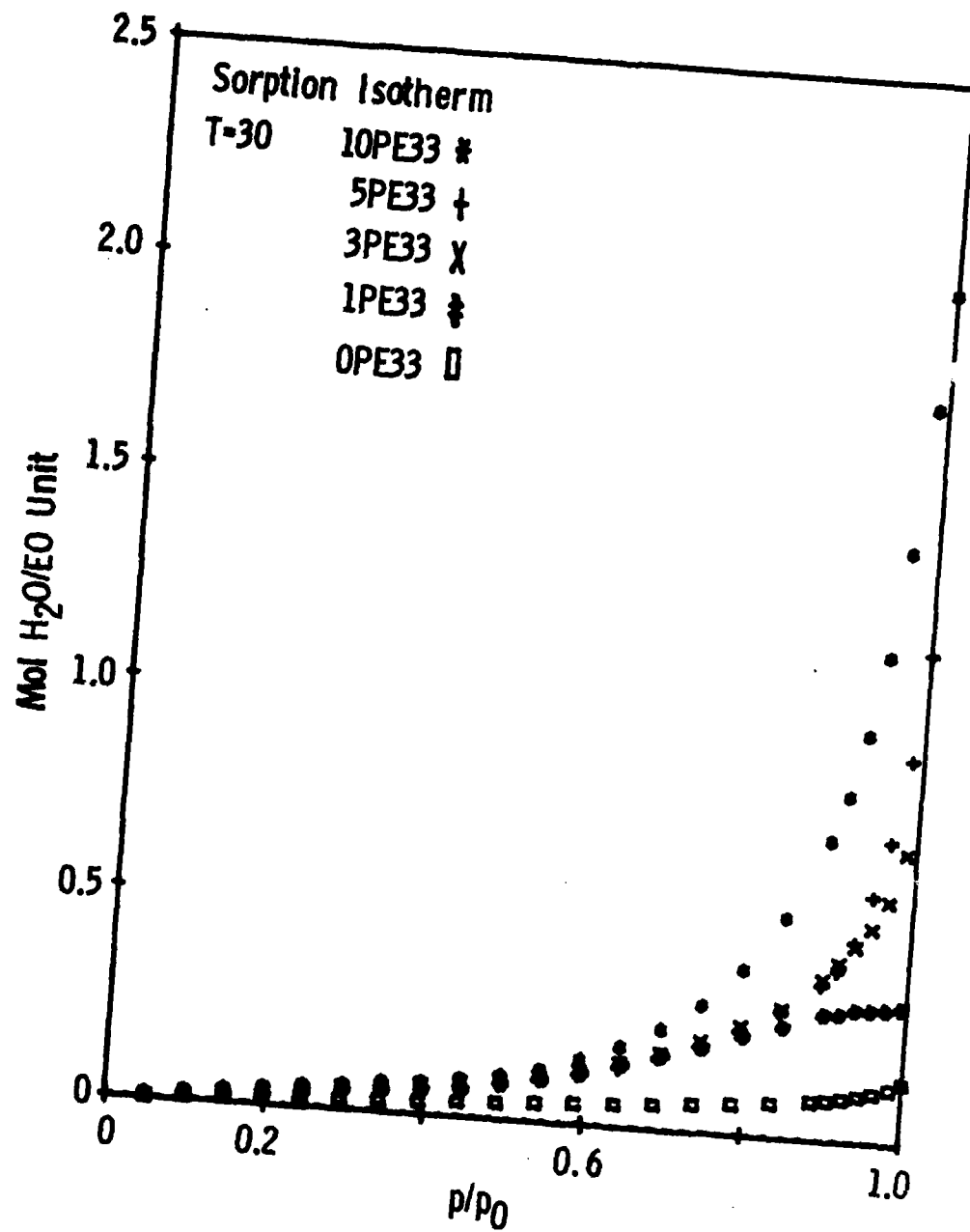

Figure 7 Sorption Isotherms, Hard Segment Variation

0.99. Table I gives the Inverse Henry's law coefficients ( $\sigma$ ) calculated from the slope of this line, after correction for the contribution of sorption by the PPO portion of the soft segment, to obtain results in terms of sorption on PEO. At a given temperature and fixed hard segment content  $\sigma$  decreases progressively with decreasing PEO content. In the three polymers with fixed 50/50 PPO/PEO content there is a small but unexpected increase in  $\sigma$  with increasing hard segment content. The results in Table III also emphasize the fact that there is relatively little effect of temperature in the linear region of the sorption isotherms for any of the samples.

#### Immersion Data

Figure 8 and Tables IV and V summarize the swelling behavior from liquid water at various temperatures. Values in Figure 8 are per cent water on total polymer, those in Tables IV are per cent on PEO portion, and in Table V molecules of  $H_2O$  per EO unit. It is apparent that under immersion conditions there are much larger differences in sorption with variations in composition than previously seen in terms of the sorption isotherms.

Figures 9 and 10 are plots of the natural logarithm of water concentration (based on PEO) versus reciprocal temperature. The heats of sorption  $\Delta H_s$  are represented by the negative slope of these curves. These values of  $\Delta H_s$  are negative over the entire temperature range

TABLE III  
 INVERSE HENRY'S LAW COEFFICIENT  
 (%H<sub>2</sub>O ON PEO/ACTIVITY)

Polymer	T(°K)		
	288	303	323
10PE33	8.9	8.1	7.2
5PE33	6.8	6.9	6.0
3PE33	-	6.2	-
1PE33*	-	4.7	-
0PE33*	2.4	2.4	2.4
5PE28	5.6	6.9	5.4
5PE33	6.8	6.9	6.0
5PE40	7.7	7.5	7.0

\*%H<sub>2</sub>O on PPO

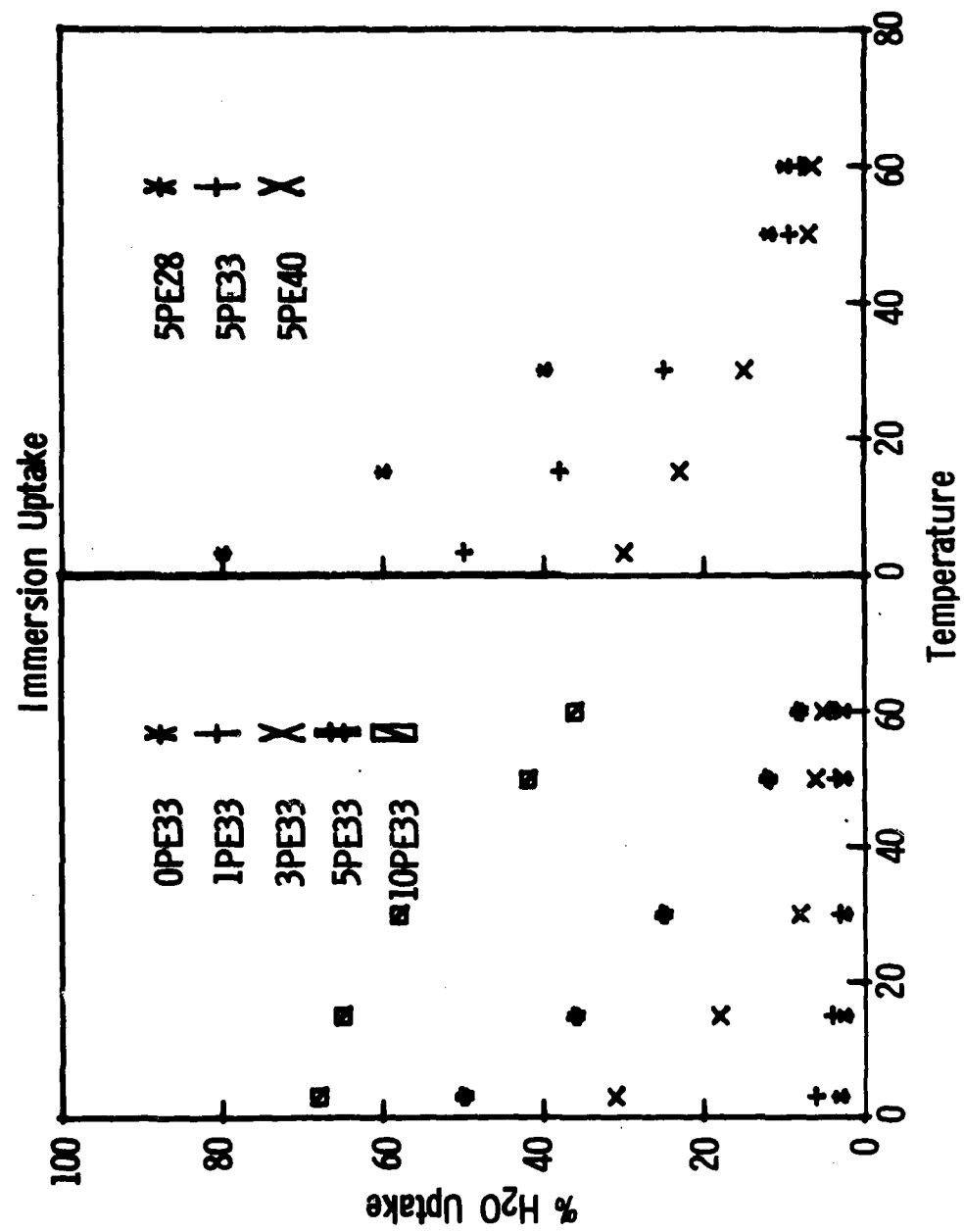

Figure 8 Immersion Uptake

TABLE IV

## IMMERSION UPTAKE

Polymer	T(°K)				
	276	288	303	323	333
10PE33	126	120	107	81	67
5PE33	167	127	83	27	20
3PE33	158	86	35	20	17
1PE33*	55	29	20	18	18
0PE33*	4.9	4.1	3.3	4.6	4.6
5PE28	226	178	118	32	26
5PE33	167	127	83	27	20
5PE40	120	92	59	23	21

g/100g PEO in polymer

\*g/100g PPO in polymer

TABLE V

## IMMERSION UPTAKE (MOLECULES/EO UNIT)

Polymers	T(°K)				
	276	288	303	323	333
10PE33	3.08	2.93	2.62	1.98	1.64
5PE33	4.08	3.10	2.03	0.66	0.49
3PE33	3.86	2.10	0.86	0.49	0.42
1PE33*	1.34	0.71	0.49	0.44	0.44
0PE33*	0.15	0.13	0.11	0.15	0.15
5PE28	5.52	4.35	2.88	0.78	0.64
5PE33	4.08	3.10	2.03	0.66	0.49
5PE40	2.93	2.25	1.44	0.56	0.51

\*per PO unit.

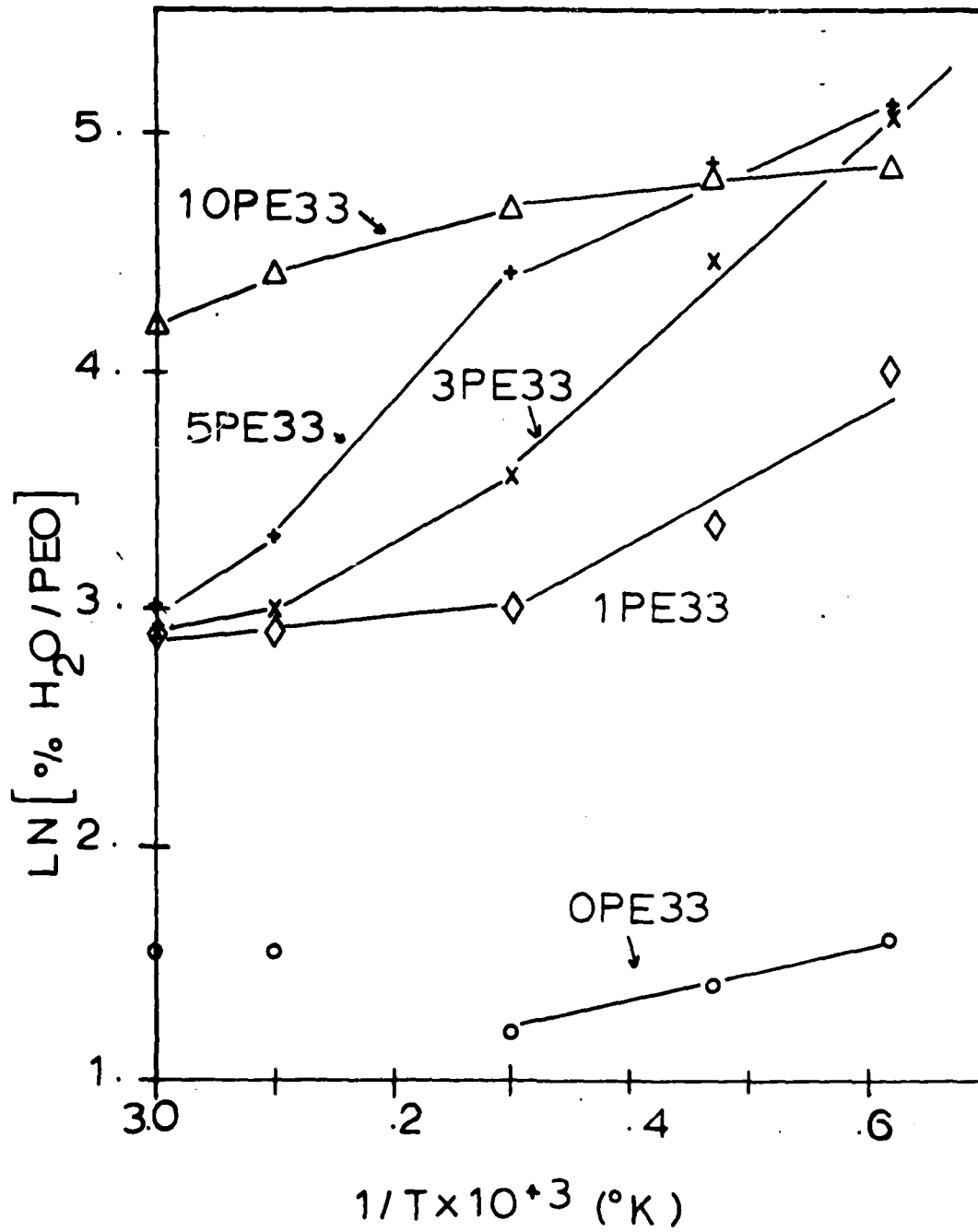

Figure 9  $\text{Ln}(\% \text{H}_2\text{O}/\text{PEO})$  vs  $1/T$  (soft segment)

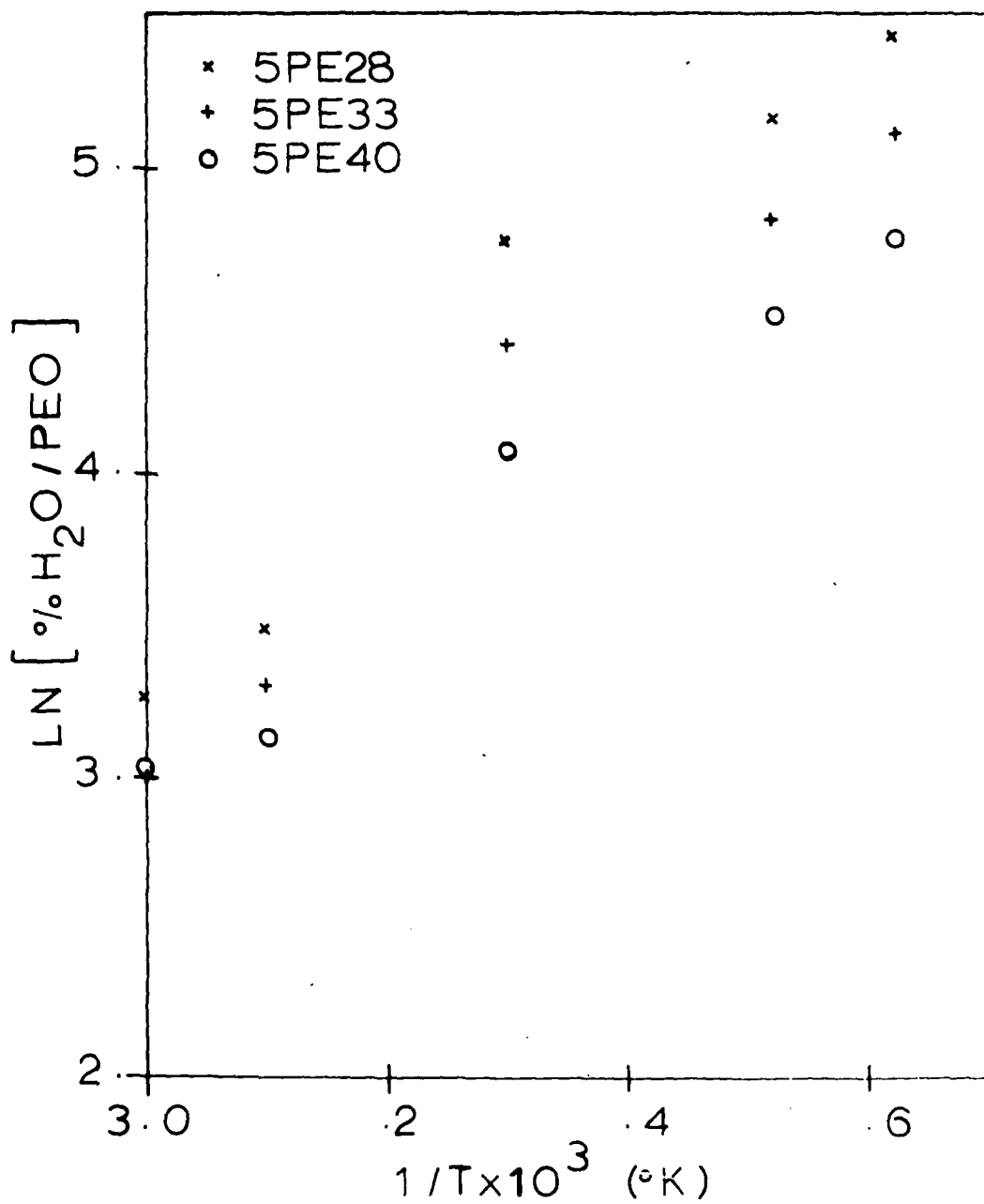

Figure 10  $\text{LN}(\% \text{H}_2\text{O} / \text{PEO})$  vs  $1/T$  (hard segment)

although the details of the variation with temperature are complex. In the polymer with pure PEO soft segment (10PE33)  $\Delta H_S$  is slightly negative and becomes more so with increasing temperature. For the sample with pure PPO soft segment (0PE33)  $\Delta H_S$  appears to change from somewhat exothermic to slightly endothermic with increase in temperature although this variation may fall within the experimental error due to the relatively small amounts of water taken up. The various polymers with block copolymer soft segments show abrupt changes in  $\Delta H_S$  between the low and high temperature intervals. This behavior is clearly displayed by the three polymers with varying hard segment content in Figure 10 which follow a parallel course with increasing temperature. The change in  $\Delta H_S$  is suggestive of a transition related to structural organization within the soft segment phase, perhaps due to a change in miscibility of the PPO and PEO blocks of these moderately swollen polymers as a function of temperature. It is interesting to note that the slope of the set of curves at higher temperatures beyond the transition region again approaches that observed at lower temperatures. Because of the various complexities illustrated in figures 9 and 10 no values of  $\Delta H_S$  have been tabulated.

#### Analysis of Solubility Behavior

Several interpretations of isotherms in terms of descriptive parameters are available. Williams, Hopfenberg and Stannett<sup>11</sup> discuss changes in the Flory-Huggins interaction parameter  $\chi$  in relation to clustering behavior of penetrant in several polymers. Trends in these values may also be indicative of an approach to solution behavior of a

polymer penetrant system. Values of  $\chi$  were calculated on the basis of total polymer and PEO concentration from the relation:

$$\chi = \frac{\ln[p/p_0] - \ln\phi_1 - \phi_2}{\phi_2^2}$$

where  $\phi_1$  and  $\phi_2$  are volume fractions of water and polymer respectively.

For the two calculations we define

$$\phi_{1T} = \frac{g/100 \text{ g polymer}}{100 + g/100 \text{ g polymer}}$$

and

$$\phi_{1PEO} = \frac{g/ \%PEO \text{ in polymer}}{\%PEO \text{ in polymer} + g/ \%PEO \text{ in polymer}}$$

Figures 11, 12 and 13 show the comparison of these values across soft segment variation in total polymer and EO content. Two trends are seen.

In the PEO polymers there is a definite decrease in  $\chi$  at high water activities showing an approach to solution behavior. This trend is even more marked in the calculation based on the EO portion of the polymer.  $\chi$  values and trends on EO are essentially the same for all PEO containing polymers. This supports the assumption that most of the water interactions occur in this portion of the polymer.

A more general thermodynamic approach to examining the sorption behavior is by means of the cluster function of Zimm and Lundberg:<sup>8</sup>

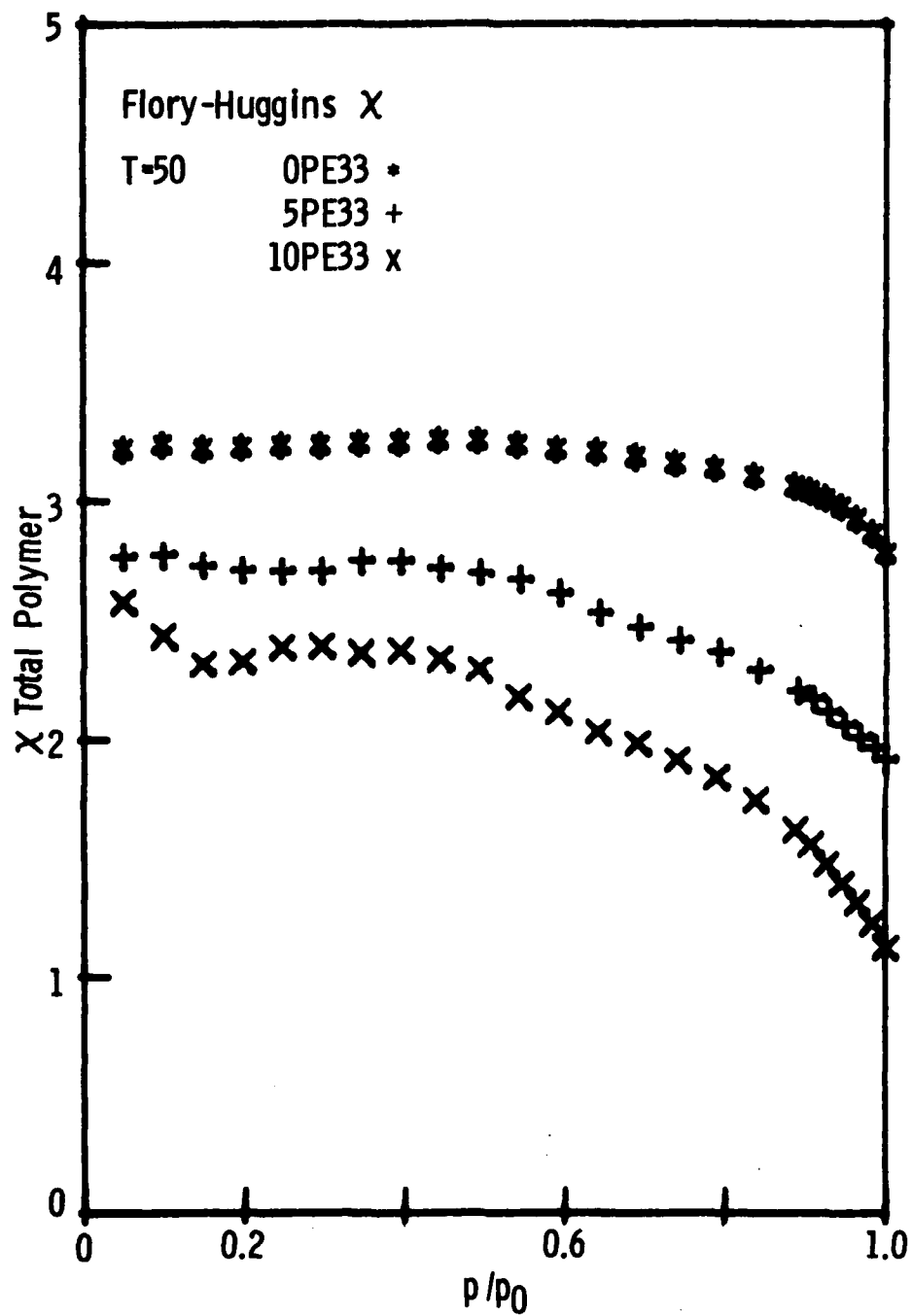

Figure 11  $\chi$ parameter, total polymer, soft segment variation

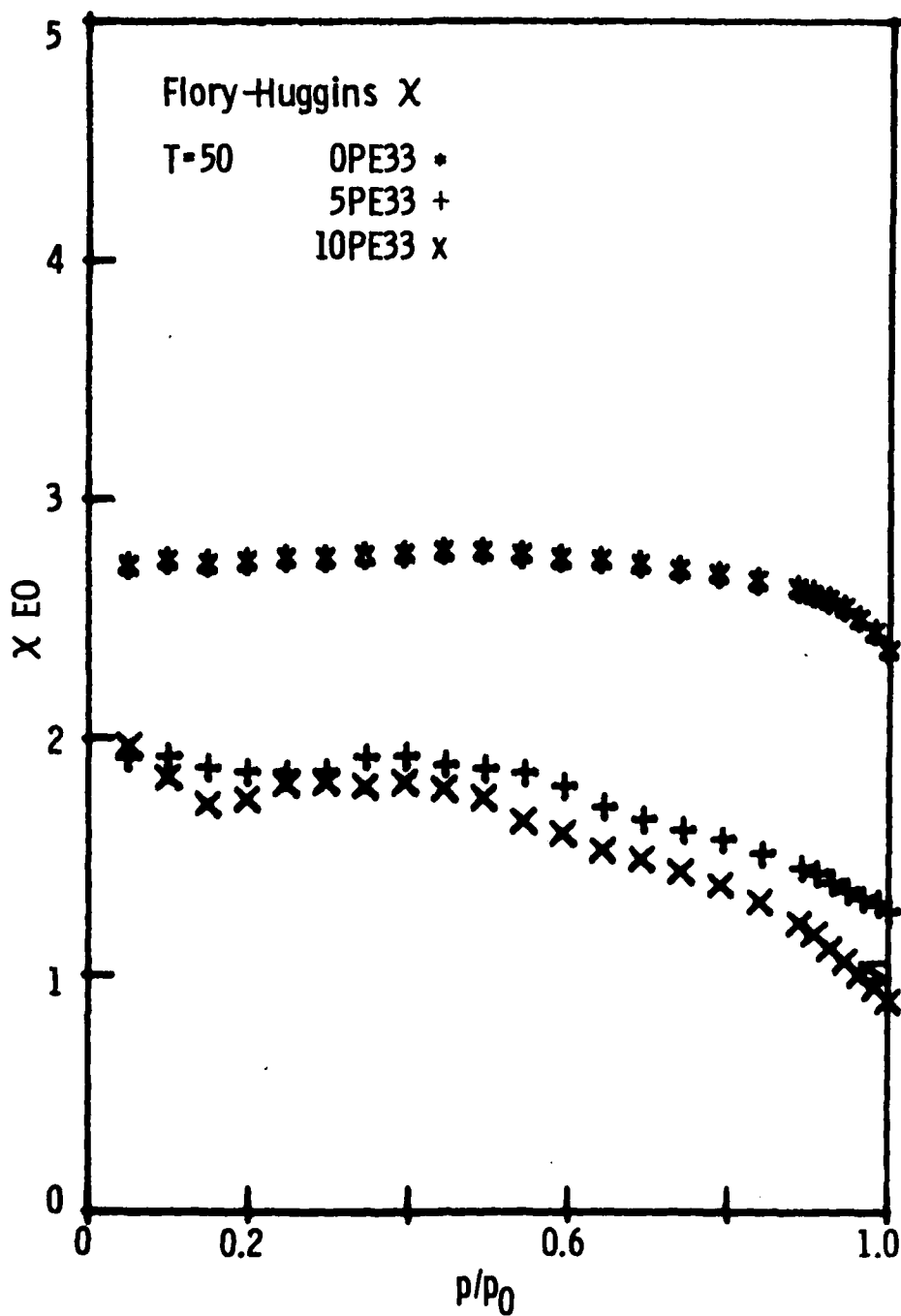

Figure 12  $\chi$  parameter, EO portion, soft segment variation

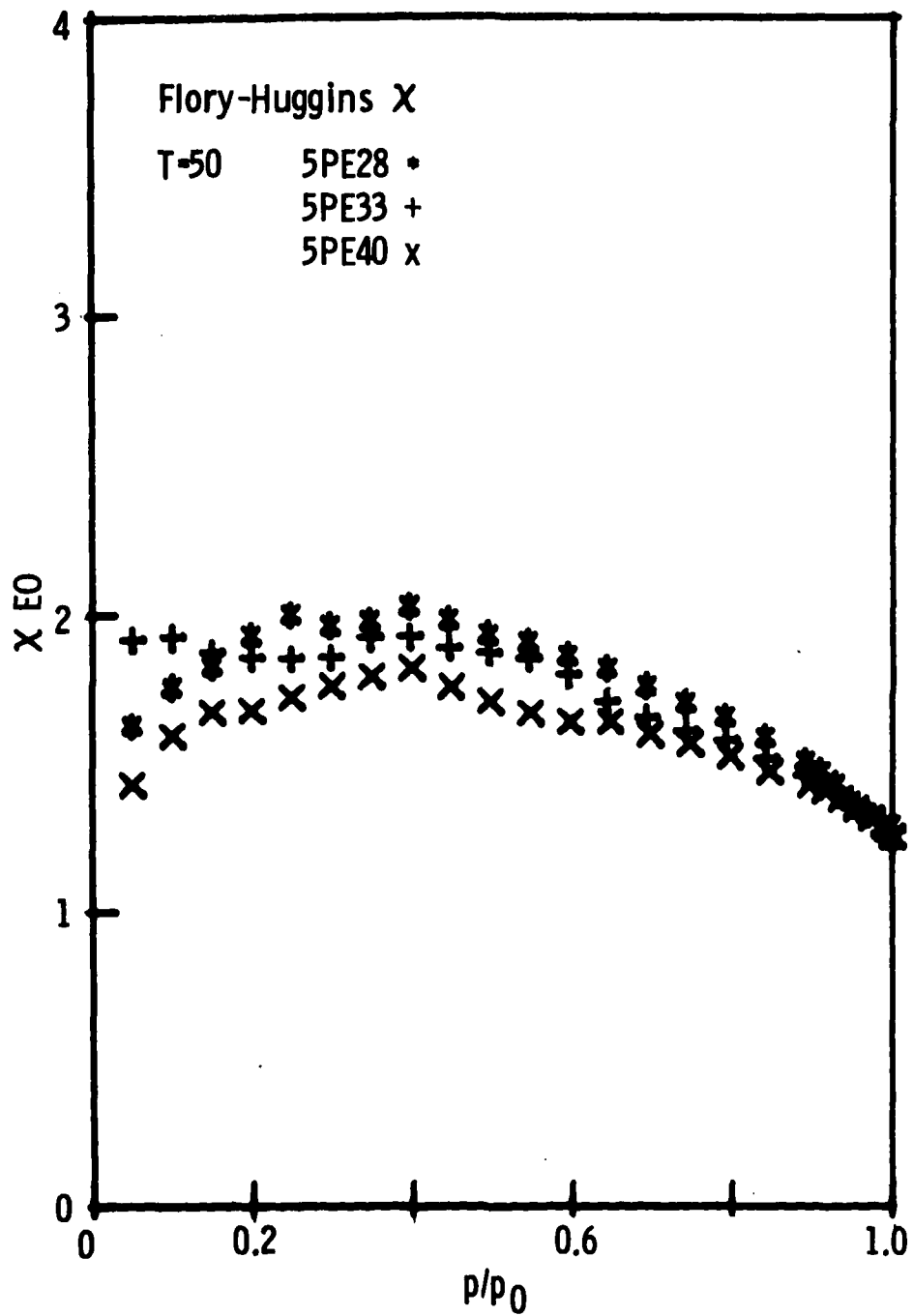

Figure 13  $\chi$ parameter E0 portion, hard segment variation

$$G_{11}/V_1 = -\phi_2 (d\gamma_1/da_1) - 1$$

where

$G_{11}$  is the cluster integral

$V_1$  is the molar volume of the solvent

$\phi_2$  is the volume fraction of polymer

$\phi_1$  is the volume fraction of solvent

$\gamma_1$  is the activity coefficient  $a_1/\phi_1$

$a_1$  is the activity of solvent

and mean cluster size:

$$1 + (G_{11} \phi_1 / V_1).$$

In addition Starkweather's<sup>9</sup> approach to calculation of a cluster number was applied using

$$w/[1 + (G_{11} \phi_1 / V_1)], \text{ with } w = \text{g/100 g polymer.}$$

Cluster parameters were calculated from tangents to the graphs of the smoothed isotherms.

These polyurethanes contain phase segregated hard segment structures. It has been found that no measurable sorption occurs on copolymers of the same composition as the hard segment. Therefore it seems appropriate to carry out the clustering analysis assuming that all sorption occurs in the soft segment phase. Starkweather, however, has noted that the choice of the entire polymer or only the amorphous fraction has little effect on the values of the clustering function. As a check on this conclusion we have carried out the analysis for two assumptions as summarized in Figures 14 and 15: (1) the total polymer is accessible to

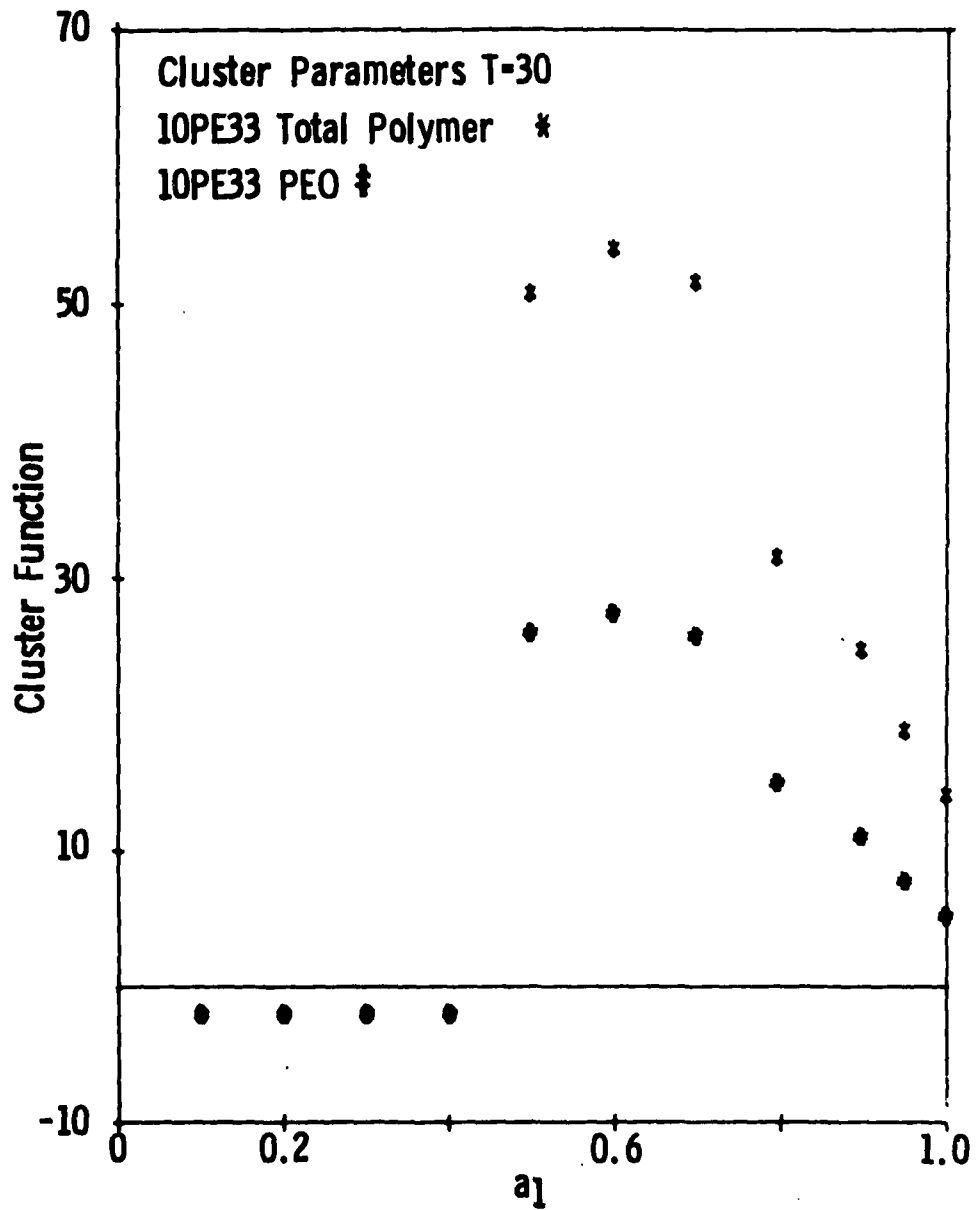

Figure 14 Cluster Function: Total Polymer and PEO portion

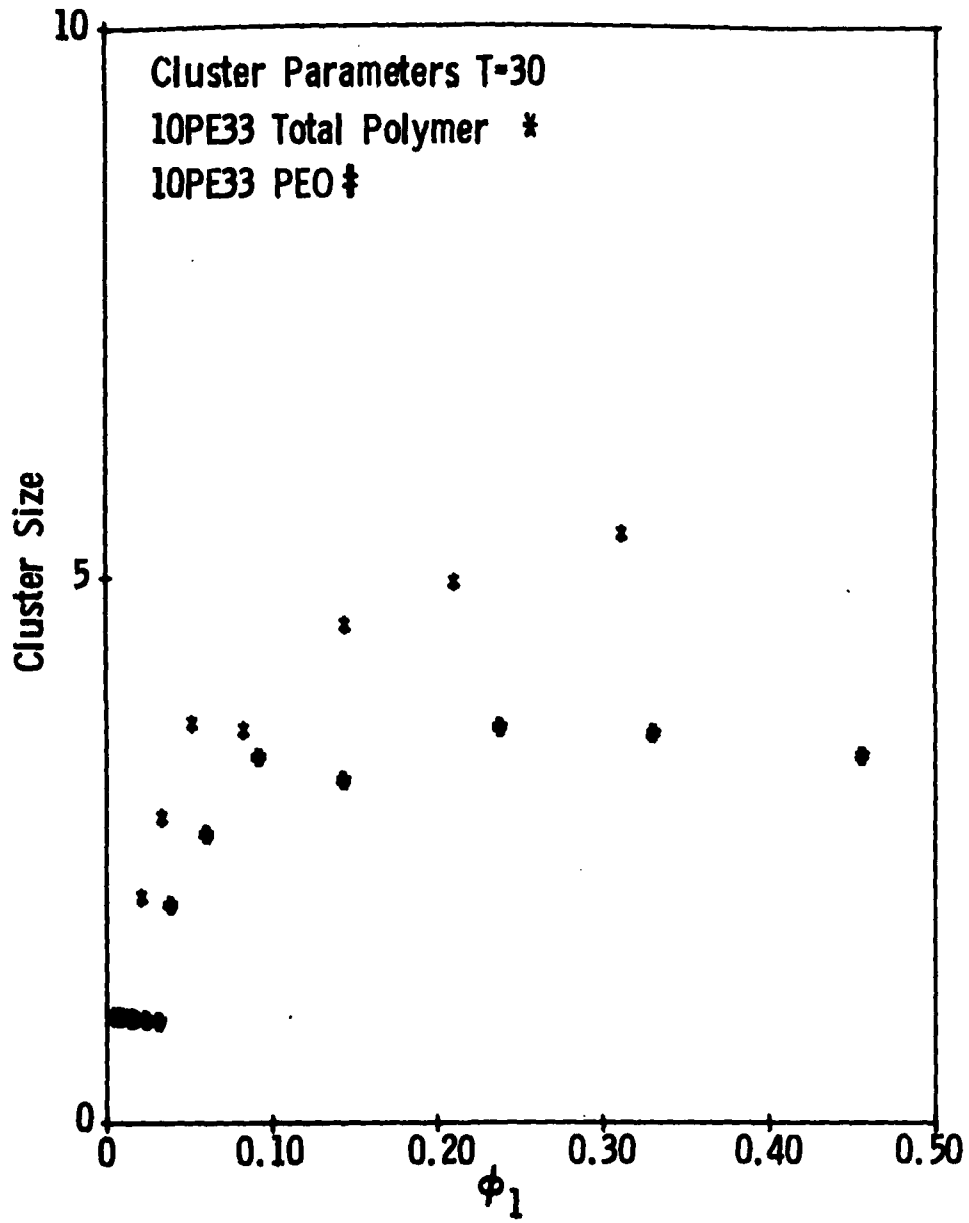

Figure 15 Cluster Size: Total Polymer and PEO portion

water or (2) sorption is confined to the PEO portion only. In the region to activity 0.4 Henry's Law behavior is assumed which neglects the gradual onset of curvature in the sorption isotherms and leads to the discontinuity in the plots of these parameters. A large reduction is seen in the calculated values of the cluster function if all water is assumed to be on the PEO portion. This would indicate less tendency to cluster as water is sorbed on the hydrophilic portion of the polymer.

Figures 16, 17 and 18 compare cluster functions, size and number across variation in soft segment composition at  $T = 50^{\circ}\text{C}$ . In the hydrophobic PPO polymer the cluster function increases continuously, particularly steeply after activity 0.8, while the PEO containing polymers reach a maximum value and then decrease. This would indicate that there is a greater tendency for water to cluster rather than interact with the PPO polymer. Just the reverse is observed for the PEO polymers even though much higher sorption levels are achieved. Cluster size in all three polymers of different soft segment composition continues to increase with increasing sorption. However, maximum size is about the same in all three, regardless of final concentration at an activity of 1.0. The change in cluster number with concentration, shown in Figure 18, reveals marked sensitivity to the soft segment composition. The pure PPO polymer goes through a maximum then decreases with a slope of  $\sim 0.25$  which, according to Starkweather's formalism, would indicate bridging of two or more clusters by incoming water molecules. The 50/50 PPO/PEO soft segment polymer reaches a maximum number and levels off, indicating that near saturation incoming molecules add to already formed clusters

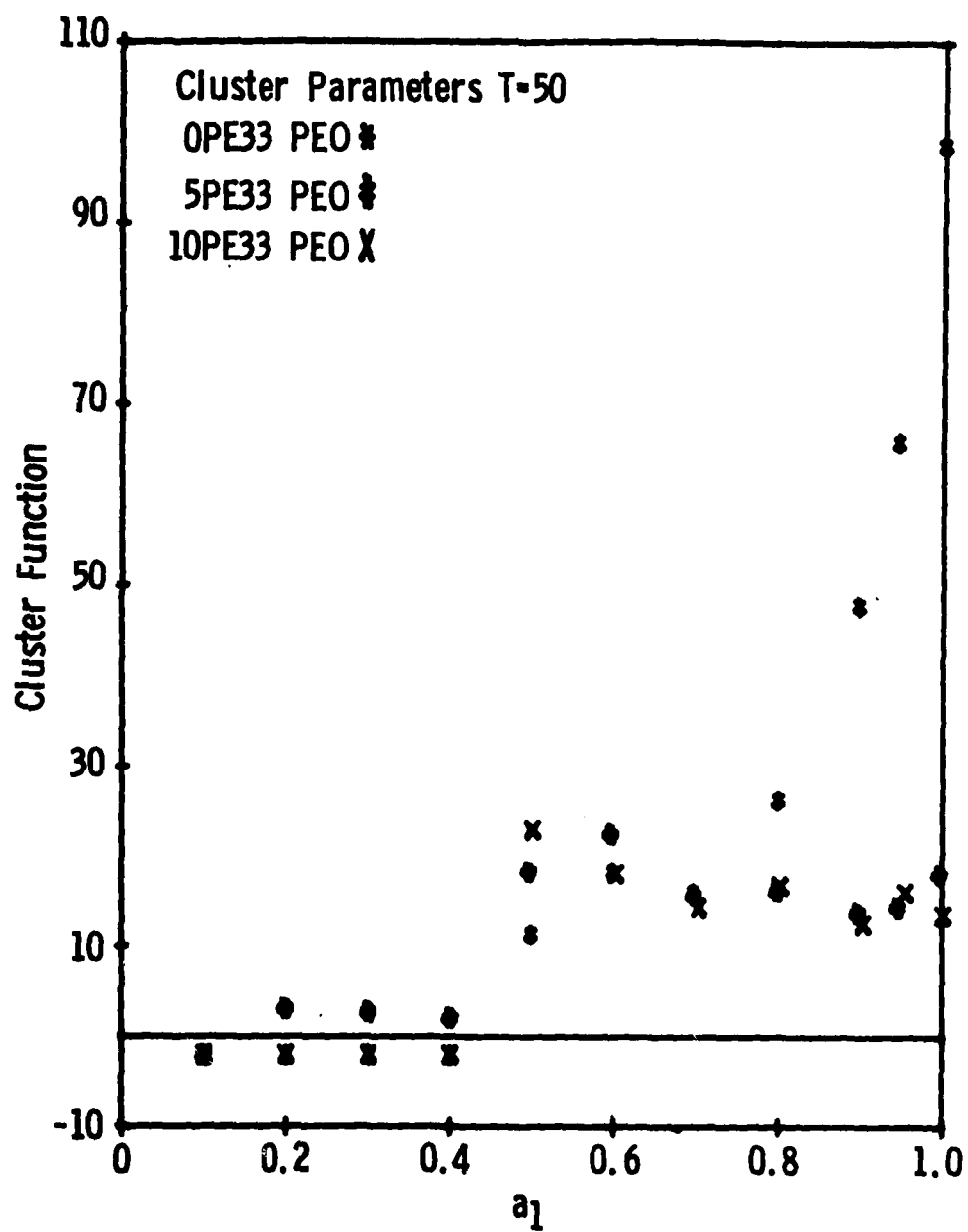

Figure 16 Cluster Function T=50; 0PE33, 5PE33, 10PE33

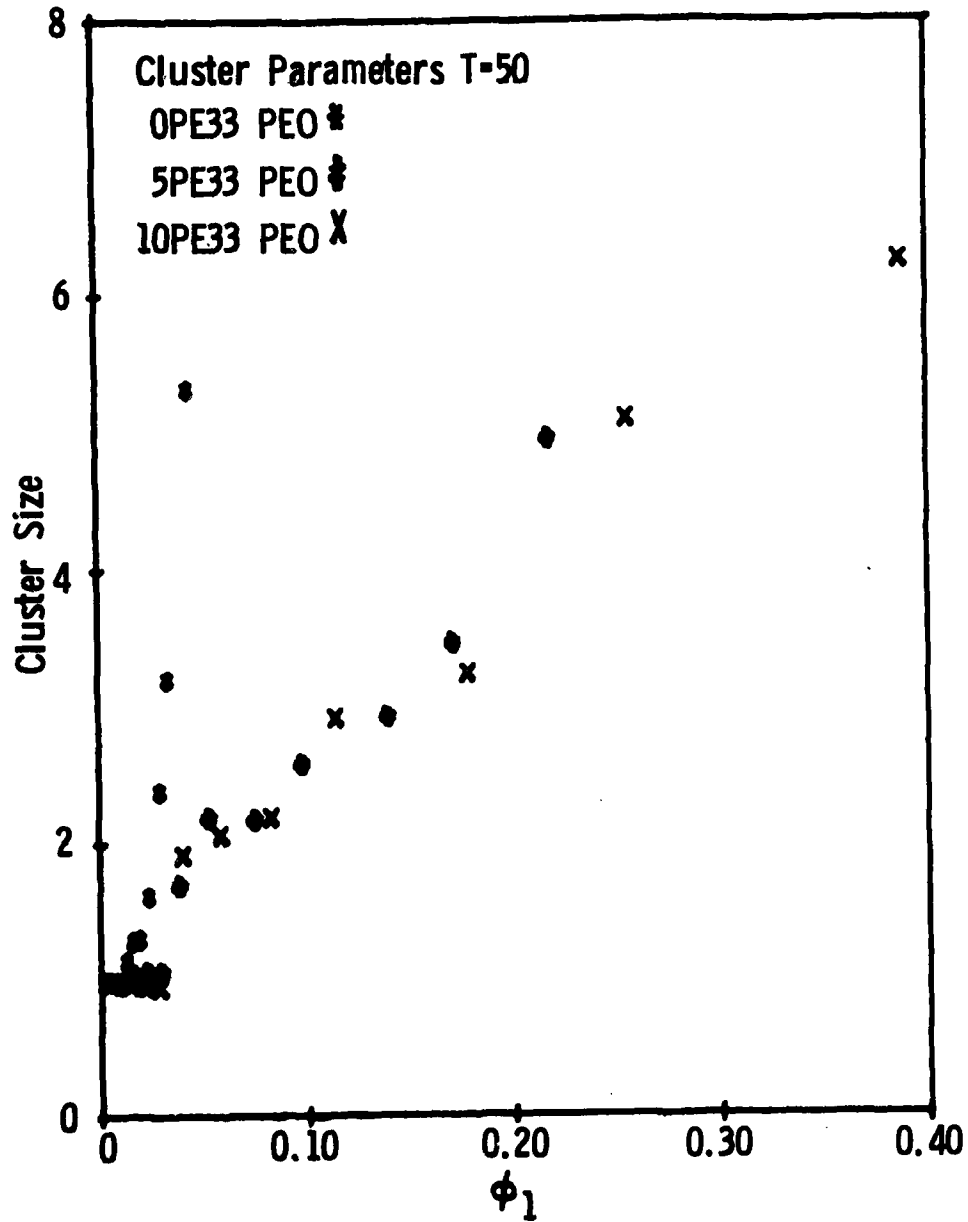

Figure 17 Cluster Size T=50; OPE33, 5PE33, 10PE33

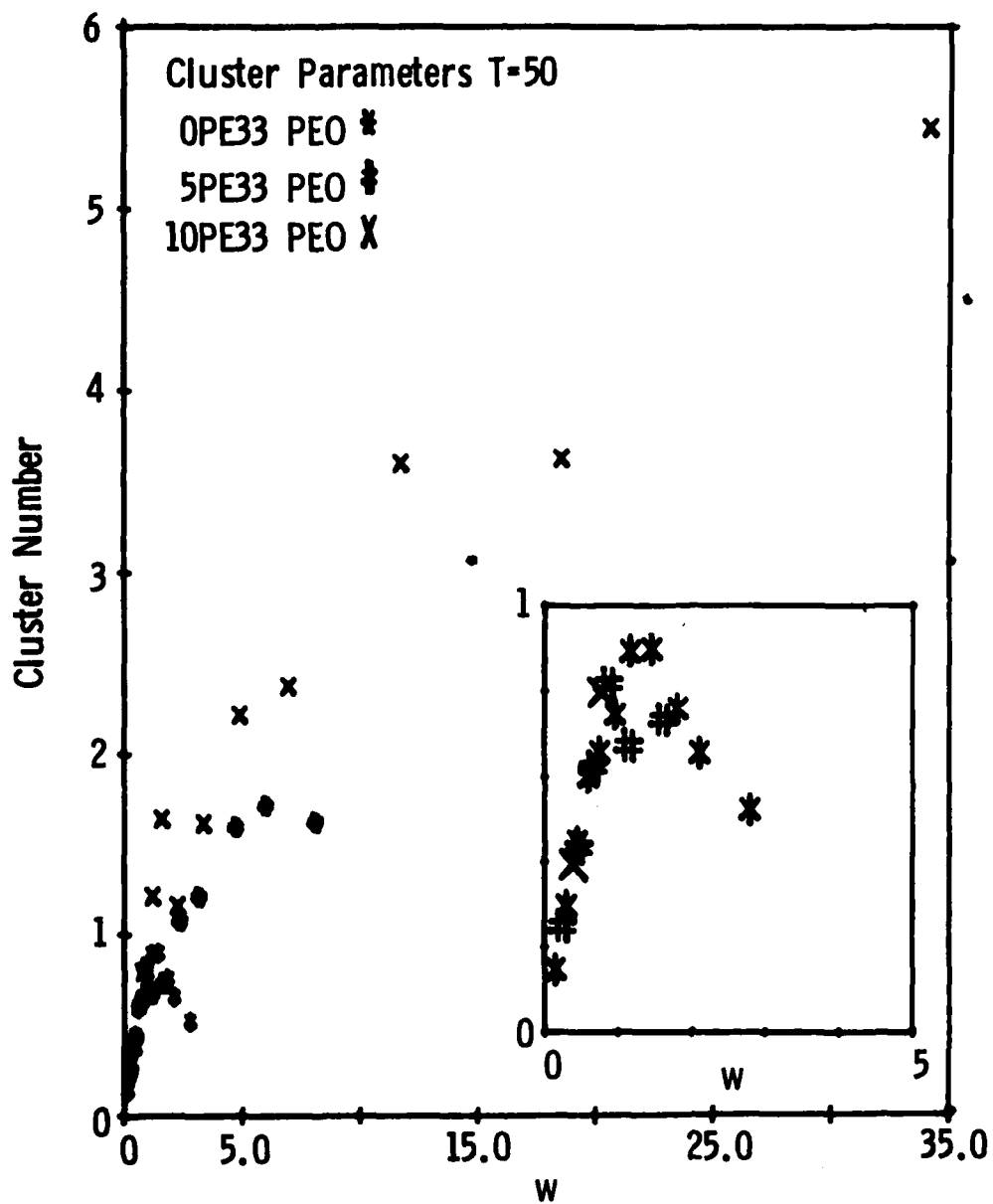

Figure 18 Cluster Number T=50; OPE33, 5PE33, 10PE33

Increasing their size. The pure PEO polymer cluster numbers continue to increase throughout the concentration range which implies continued nucleation of clusters with the cluster size increasing to moderate levels as depicted in figure 17. The variation in clustering behavior with variation in hard segment content is shown in Figures 19, 20 and 21 at  $T = 30$ . Relatively little variation in the behavior of the cluster function is seen. Cluster size increases in a parallel manner for all three samples but reaches maximum sizes of 5 in SPE40, 8 in SPE33 and 6 in SPE28. However there are more pronounced differences in cluster number behavior for the three samples. Bridging is indicated for SPE40, there is leveling off which represents addition to clusters in SPE33 and continued nucleation is implied in SPE28.

#### Diffusion Behavior

Diffusion coefficients,  $D$ , were calculated from the transients at each step of the determination of the isotherm. The approximation involving the time to reach a sorption level one-half that at equilibrium was used as,

$$(t/l^2)_{1/2} = \frac{-\ln [(\pi^2/16) - 1/9(\pi^2/16)^9]}{\pi^2 / D_{t_{1/2}}}$$

which upon rearrangement gives

$$D_{t_{1/2}} = \frac{0.04939 l^2}{t_{1/2}}$$

This approach assumes constant diffusion coefficient and an initial

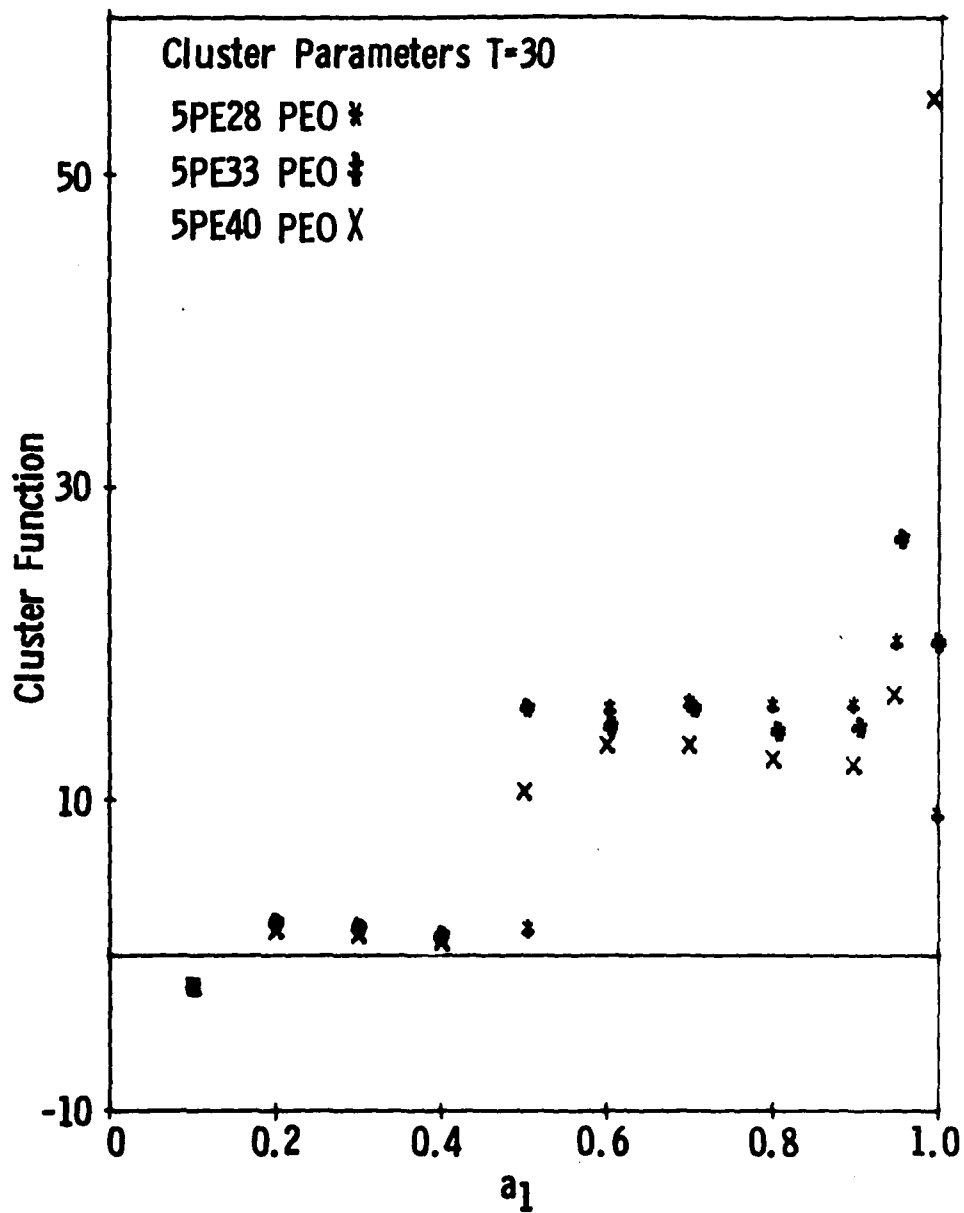

Figure 19 Cluster Function T=30; 5PE28, 5PE33, 5PE40

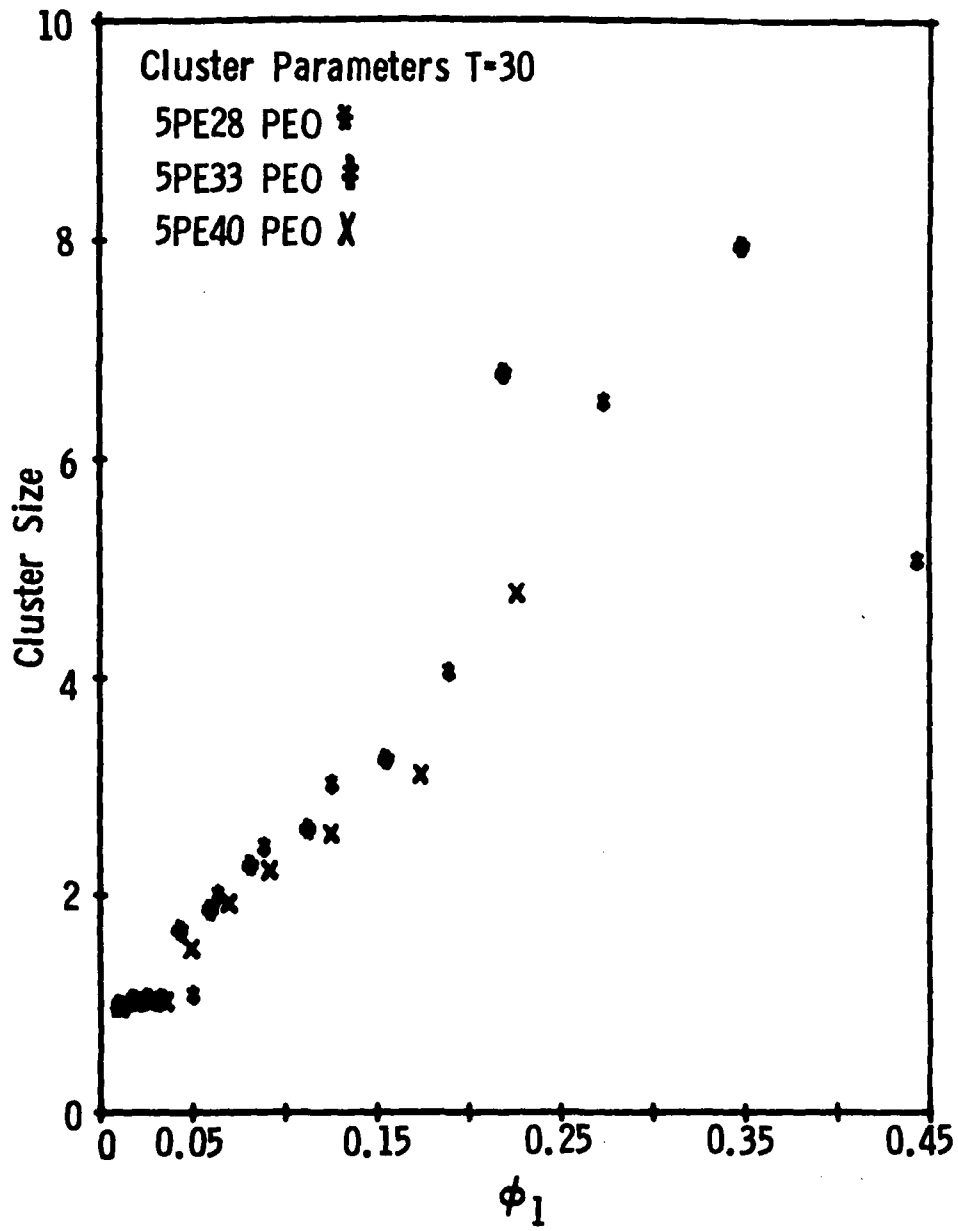

Figure 20 Cluster Size T=30; 5PE28, 5PE33, 5PE40



concentration,  $c_1 = 0$ . Because these coefficients are calculated from small  $p/p_0$  intervals where  $c_{i-1}$  has a finite value a correction was applied from:

$$D_{i\text{corr}} = \frac{(D_{i-1\text{corr}}) (c_{i-1}) + D_{t_{1/2}} (c_i - c_{i-1})}{c_i}$$

Figure 22 shows the change of the diffusion coefficients so calculated with both temperature and concentration. We have chosen to use activity rather than concentration as the abscissa to spread out the data. The diffusion coefficients increase by an order of magnitude with increasing temperature over the range studied. We also note that these coefficients decrease continuously as the activity increases, and that this decrease is greatest at high activity. The squares and diamonds are values of  $D$  calculated from steady state transmission assuming that  $D = P/S$ .  $P$  is the steady state permeability from the Mocon instrument or the cup cell measurements, and  $S$  is taken from the isotherms and immersion data. Agreement at low activity is good, but the values at saturation deviate markedly from  $D$  calculated from kinetics of sorption. Since the conditions of measurement are so different this is not unexpected. Changes in both cluster size and number are more marked in this high activity region. The kinetic measurement may reflect time dependent effects which have been eliminated during attainment of steady state conditions.

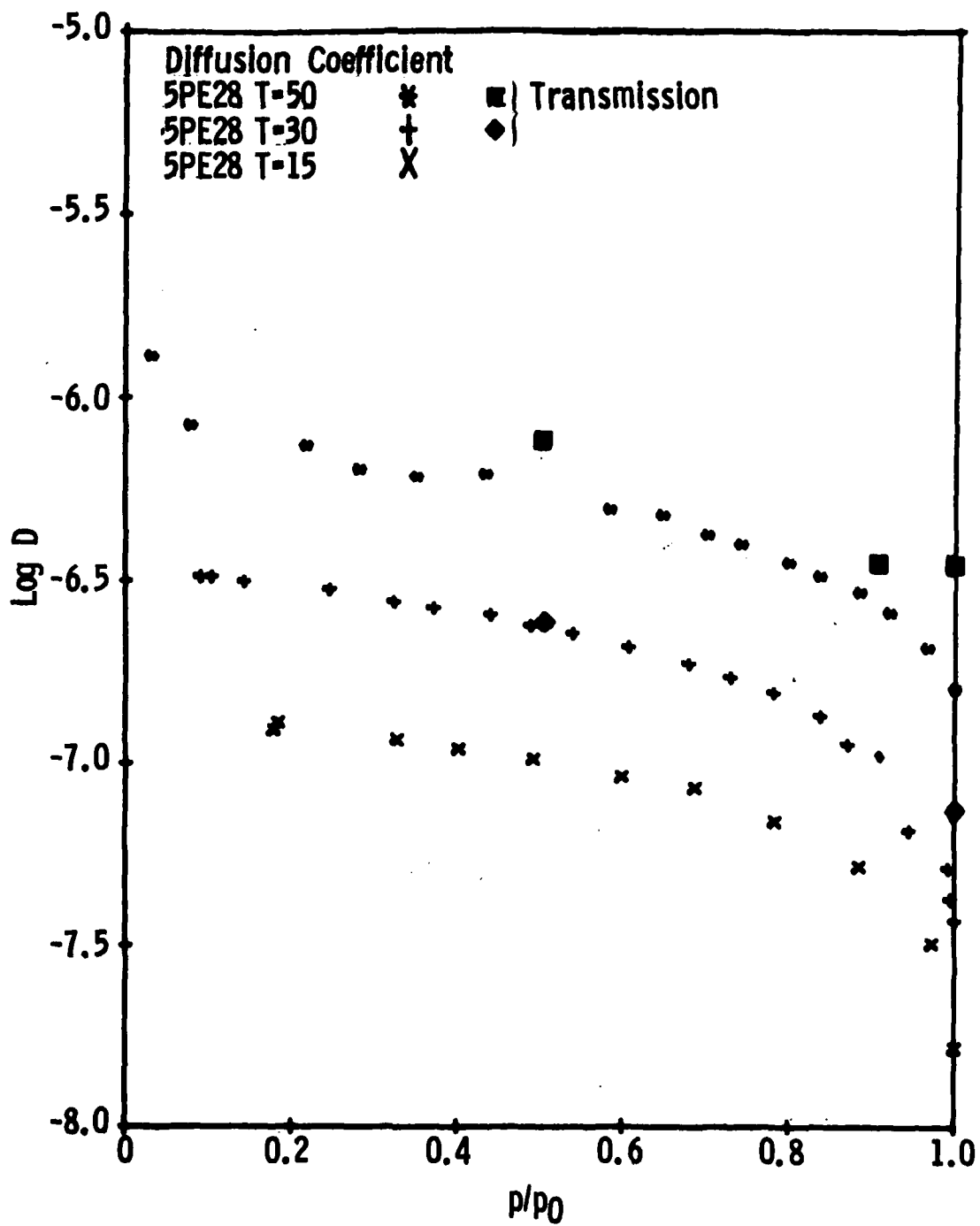

Figure 22 Diffusion Coefficient 5PE28; T = 50, 30, 15

Tables VI and VII present the values of the diffusion coefficients from the various methods of measurement as a function of activity and variation in polymer structure. As the soft segment is varied (Table VI) the coefficients decrease with increasing PEO concentration at constant activity. Figure 23 compares this diffusion behavior across variation in soft segment as a function of concentration. The continuous decrease in  $D$  from very lowest concentration is in marked contrast to that reported by Barrie<sup>12</sup> who found that there was an initial region of low concentration where the diffusion coefficient is constant. He concluded that this showed that a critical concentration of water was required for clustering. Our results imply that in these urethane systems this does not occur. Rather there are probably two competing effects which decrease  $D$  even at the lowest sorption levels. At low activity and water content specific polymer water interaction immobilize some of the water and then at higher concentrations clustering contributes more heavily to the decrease in  $D$ .

The diffusion behavior as the hard segment content is changed does not allow a simple interpretation. Both Table VII and Figure 24 show that the polymer 5PE33 shows higher rates of diffusion than polymers with either higher or lower hard segment concentration. The decrease in  $D$  is less marked in these polymers as seen in Figure 24. The fact that 5PE33 shows higher rates than those polymers at higher and lower hard segment composition may indicate a balance in effect between hydrophilicity of soft segment and blocking effect of hard segment.

TABLE VI  
DIFFUSION COEFFICIENTS  
( $\text{cm}^2/\text{sec}$ )  $\times 10^8$

Polymers	Activity								
	0.5		0.8	0.9		1.0			
	*	+	*	*	+	*	+	†	
10PE33									
50°C	55.9	45.8	29	19	19.6	7.6	19.8	-	
30°C	-	16.7	12	7	6.6	4.3	6.9	14.9	
26°C	13.0	-	11	-	-	-	-	-	
15°C	7.9	-	5.4	3.3	-	1.7	-	-	
5PE33									
50°C	80	72.6	51	40	35.6	25	33.8	-	
30°C	25	22.1	18	12	10.7	5.9	7.6	7.8	
15°C	8.7	-	6.8	4.9	-	1.8	-	-	
0PE33									
50°C	90	72.6	67	60	60.4	45	56.3	-	
30°C	20	22.0	17	16	18.0	11	17.5	24.1	
15°C	4.3	-	3.7	3.4	-	3.0	-	-	

\* from isotherms  
+ from Mocon transmission  
† from cup cell transmission



TABLE VII  
 DIFFUSION COEFFICIENTS  
 ( $\text{cm}^2/\text{sec}$ )  $\times 10^8$

Polymers	Activity							
	0.5		0.8	0.9		1.0		
	*	+	*	*	+	*	+	†
SPE28								
50°C	58	76.1	36.5	26.6	38.1	15.7	36.0	-
30°C	24	24.9	14.9	9.4	10.9	3.7	7.6	8.4
15°C	10.1	-	6.6	4.8	-	1.6	-	-
SPE33								
50°C	80	72.6	51	40	35.6	25	33.8	-
30°C	25	22.1	18	12	10.7	5.9	7.6	7.8
15°C	8.7	-	6.8	4.9	-	1.8	-	-
SPE40								
50°C	53	56.7	35.5	28.4	30.8	18.8	33.5	-
30°C	14.8	17.2	11.5	9.6	8.9	3.7	8.4	6.6
15°C	4.5	-	3.8	3.3	-	1.5	-	-

\* from Isotherms  
 + from Mocon transmission  
 † from cell transmission

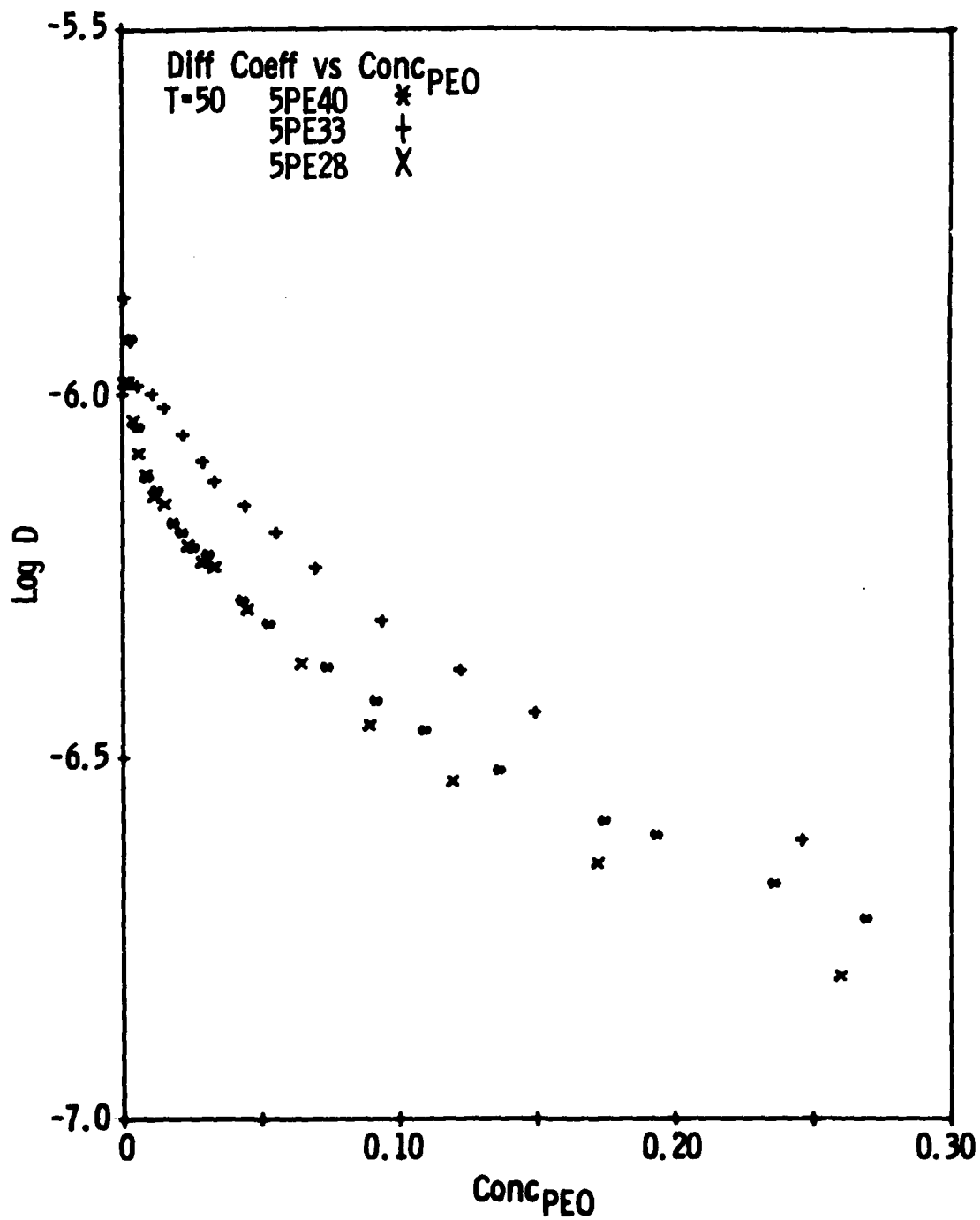

Figure 24 Diffusion Coefficient T=50, 5PE28, 5PE33, 5PE40

## REFERENCES

1. Illinger, J. L., Schnelder, N. S. and Karasz, F. E., in "Permeability of Plastic Films to Gases, Vapors and Liquids" Hopfenberg, H. B. ed, Plenum Press, New York (1975) p. 183.
2. Crank, J. "The Mathematics of Diffusion" Oxford University Press (1956).
3. Rogers, C. E., and Machin, D., CRC Critical Reviews in Macromol. Sci., p. 245 April (1972).
4. Rogers, C. E. In 'Physics and Chemistry of the Organic Solid State', Fox, D., Labes, M. M. and Weissberger, A., eds, Interscience, New York, (1965) Chap 6.
5. Schnelder, N. S., Dusablon, L. V., Snell, E. W. and Prosser, R. A., J. Macromol. Sci-Phys B3 623 (1969).
6. Barrie, J. and Machin, D., J. Macromol. Sci-Phys B3 645 (1969).
7. Yasuda, H. and Stannett, V., J. Macromol. Sci-Phys B3 589 (1969).
8. Zimm, B. and Lundberg, J. L., J. Phys. Chem 60, 425 (1969) and Lundberg, J. L., J. Macromol. Sci-Phys, B3 693 (1969).
9. Starkweather, H. J. Jr., Macromolecules 8, 476 (1975).
10. Wood, R., Modern Converter, September and October (1970).
11. Williams, J. L., Hopfenberg, H. B. and Stannett, V., J. Macromol Sci-Phys, B3, 711 (1969).
12. Barrie, J. A., Machin, D. and Nunn, A., Polymer, 16 811 (1975).

## RECOMMENDATIONS

This dissertation has merely explored the tip of an iceberg. Many additional tributaries remain which should be explored. A few of these are charted below:

(1) Explore a wider range of water content in these polymers, particularly in the pure PEO polymers, to examine the much greater effects upon  $T_g$  of added water than current theory based upon free volume can explain. Examine the low water content region in these polymers hitherto not investigated. The experiments have indicated that the reequilibration between free and bound water occurs slowly as temperature is changed. The kinetics of this process should be studied.

(2) Resolution of the anomalous rise in  $T_m$  of water seen in these wet polymers using large sample pans under helium purge against 78°K block temperature. Calculate and/or measure the temperature gradients at these conditions. Explore the possibility that this behavior is not an artifact and that sufficient local internal pressure may be generated to raise  $T_m$  of water.

(3) Measure diffusion coefficients with additional techniques at higher and lower hard segment content of the 50/50 PEO/PEO soft segment polymers to clarify structure effects which now show that an intermediate molar content of MDI-Bd shows a maximum in diffusion coefficient. In particular, the determination of steady state transmission rates as a

function of upstream pressure needs to be carried out. A linear dependence in conjunction with the initial Henry's law region of sorption behavior would imply that the diffusion constant is initially independent of concentration, in contrast to the conclusion drawn from the transient sorption behavior.

(4) Pursue more detailed analysis of immersion data over a broader temperature range at narrower temperature intervals to correlate negative heats of sorption with polymer structure, and develop a model for this behavior.

(5) Pursue additional diffusion measurements at closer temperature intervals and over a wider range of temperature to more clearly delineate the concentration dependence of the diffusion coefficient as a function of soft segment composition.

## ACKNOWLEDGEMENTS

The author wishes to express her gratitude to Professor Frank E. Karasz and to Dr. Nathaniel S. Schneider for the guidance, encouragement and support they provided throughout this endeavor. Fruitful discussion with Dr. Dennis B. Barr, Dr. Robert W. Lewis, and Dr. C. Richard Desper, of AMMRC and Professor William MacKnight and Professor Otto Vogl of U. Mass, are gratefully acknowledged. Miss Deborah Clark was of great help in measuring many of the sorption isotherms and reducing data therefrom.

The author wishes to acknowledge the Army Materials and Mechanics Research Center for support of this work. Particular thanks are due to Dr. George R. Thomas, Chief of the Organic Materials Laboratory, and Dr. Wenzel E. Davidsohn, Chief of the Polymer and Chemistry Division for their help, encouragement and consideration throughout this program. The support and encouragement of all my colleagues in the Polymer and Chemistry Division in many stages of this work is also greatly appreciated.

Yeoman work by Carolyn Shimansky and Christopher Peppel for typing and John Beres for drawings is gratefully acknowledged, as is the support of the Technical Reports Section of AMMRC, particularly Mr. Robert Roderick, for the production of the final document.

UNCLASSIFIED  
UNLIMITED DISTRIBUTION  
Polyurethanes  
Water vapor transport  
Water interactions  
Key Words

Army Materials and Mechanics Research Center,  
Watertown, Massachusetts 02172  
INTERACTIONS OF WATER WITH HYDROPHILIC POLYETHER POLYURETHANES -  
Joyce L. Illinger  
Technical Report AMMRC TR 82-39, June 1982, 130 pp.  
Illustrations, D/A Project 111611024H42

Two series of polyurethanes based on MDI, butanediol and several block copolymer polyethers with varying proportions of poly(ethyleneoxide) PEO and poly(propyleneoxide) PPO have been synthesized. All these materials are tough film forming elastomers of approximately same molecular weight. At constant hard block composition and decreasing amounts of PEO or PPO, the polymer soft segment content decreases. Amounts of water uptake increase as temperature decreases. Decrease in water uptake is most marked under immersion conditions or when sorption isotherm is measured at saturation conditions. However, trends are the same for both situations. When the hard block composition is varied a similar decrease in water uptake with increase in hard segment composition is seen, though not so marked. The sorption isotherms are surprisingly simple concave upward curves which rise very steeply at saturation. Analysis of the data on the basis of moles of water per ED unit indicates influence of compositional variations on the sorption isotherms and shows that saturation water concentrations are not related in a simple manner to PEO concentration. The diffusion coefficient, D, for water through these polymers decreases with increasing water concentration in the polymer and with decreasing temperature. Ethylene oxide content and hard segment content also affect the concentration dependence of D. Cluster function, size and number show very different behavior with water concentration from the pure propylene oxide soft segment polymer through block copolymer soft segment polymers to the ethylene oxide soft segment polymer. The limiting rate of steady water equilibration to 10% intervals from 273° to 323°K. As T was lowered the water melting endotherm diminished in size indicating that more water was bound to the polymer. The polymer soft segment T<sub>g</sub> at the T<sub>g</sub> was close to that of dry polymer but decreased by as much as 40° with increasing T<sub>g</sub> in certain samples. Values of T<sub>g</sub> correlate with amount of bound water estimated from DSC endotherm rather than with total amount of water added to the polymer. The results could be accounted for in terms of the standard free volume theory of diluent depression of T<sub>g</sub>, but T<sub>g</sub> depression in the PEO polymer is larger than expected from these calculations, suggesting that there are additional effects due to water polymer interactions.

UNCLASSIFIED  
UNLIMITED DISTRIBUTION  
Polyurethanes  
Water vapor transport  
Water interactions  
Key Words

Army Materials and Mechanics Research Center,  
Watertown, Massachusetts 02172  
INTERACTIONS OF WATER WITH HYDROPHILIC POLYETHER POLYURETHANES -  
Joyce L. Illinger  
Technical Report AMMRC TR 82-39, June 1982, 130 pp.  
Illustrations, D/A Project 111611024H42

Two series of polyurethanes based on MDI, butanediol and several block copolymer polyethers with varying proportions of poly(ethyleneoxide) PEO and poly(propyleneoxide) PPO have been synthesized. All these materials are tough film forming elastomers of approximately same molecular weight. At constant hard block composition and decreasing amounts of PEO or PPO, the polymer soft segment content decreases. Amounts of water uptake increase as temperature decreases. Decrease in water uptake is most marked under immersion conditions or when sorption isotherm is measured at saturation conditions. However, trends are the same for both situations. When the hard block composition is varied a similar decrease in water uptake with increase in hard segment composition is seen, though not so marked. The sorption isotherms are surprisingly simple concave upward curves which rise very steeply at saturation. Analysis of the data on the basis of moles of water per ED unit indicates influence of compositional variations on the sorption isotherms and shows that saturation water concentrations are not related in a simple manner to PEO concentration. The diffusion coefficient, D, for water through these polymers decreases with increasing water concentration in the polymer and with decreasing temperature. Ethylene oxide content and hard segment content also affect the concentration dependence of D. Cluster function, size and number show very different behavior with water concentration from the pure propylene oxide soft segment polymer through block copolymer soft segment polymers to the ethylene oxide soft segment polymer. The limiting rate of steady water equilibration to 10% intervals from 273° to 323°K. As T was lowered the water melting endotherm diminished in size indicating that more water was bound to the polymer. The polymer soft segment T<sub>g</sub> at the T<sub>g</sub> was close to that of dry polymer but decreased by as much as 40° with increasing T<sub>g</sub> in certain samples. Values of T<sub>g</sub> correlate with amount of bound water estimated from DSC endotherm rather than with total amount of water added to the polymer. The results could be accounted for in terms of the standard free volume theory of diluent depression of T<sub>g</sub>, but T<sub>g</sub> depression in the PEO polymer is larger than expected from these calculations, suggesting that there are additional effects due to water polymer interactions.

UNCLASSIFIED  
UNLIMITED DISTRIBUTION  
Polyurethanes  
Water vapor transport  
Water interactions  
Key Words

Army Materials and Mechanics Research Center,  
Watertown, Massachusetts 02172  
INTERACTIONS OF WATER WITH HYDROPHILIC POLYETHER POLYURETHANES -  
Joyce L. Illinger  
Technical Report AMMRC TR 82-39, June 1982, 130 pp.  
Illustrations, D/A Project 111611024H42

Two series of polyurethanes based on MDI, butanediol and several block copolymer polyethers with varying proportions of poly(ethyleneoxide) PEO and poly(propyleneoxide) PPO have been synthesized. All these materials are tough film forming elastomers of approximately same molecular weight. At constant hard block composition and decreasing amounts of PEO or PPO, the polymer soft segment content decreases. Amounts of water uptake increase as temperature decreases. Decrease in water uptake is most marked under immersion conditions or when sorption isotherm is measured at saturation conditions. However, trends are the same for both situations. When the hard block composition is varied a similar decrease in water uptake with increase in hard segment composition is seen, though not so marked. The sorption isotherms are surprisingly simple concave upward curves which rise very steeply at saturation. Analysis of the data on the basis of moles of water per ED unit indicates influence of compositional variations on the sorption isotherms and shows that saturation water concentrations are not related in a simple manner to PEO concentration. The diffusion coefficient, D, for water through these polymers decreases with increasing water concentration in the polymer and with decreasing temperature. Ethylene oxide content and hard segment content also affect the concentration dependence of D. Cluster function, size and number show very different behavior with water concentration from the pure propylene oxide soft segment polymer through block copolymer soft segment polymers to the ethylene oxide soft segment polymer. Scanning calorimetry from 150° to 323°K was performed on these sets of polymers. The polymer samples with fixed amount of added water were equilibrated to 10% intervals from 273° to 323°K. As T<sub>g</sub> was lowered the water melting endotherm diminished in size indicating that more water was bound to the polymer. The polymer soft segment T<sub>g</sub> at the T<sub>g</sub> was close to that of dry polymer but decreased by as much as 40° with increasing T<sub>g</sub> in certain samples. Values of T<sub>g</sub> correlate with amount of bound water estimated from DSC endotherm rather than with total amount of water added to the polymer. The results could be accounted for in terms of the standard free volume theory of diluent depression of T<sub>g</sub>, but T<sub>g</sub> depression in the PEO polymer is larger than expected from these calculations, suggesting that there are additional effects due to water polymer interactions.

UNCLASSIFIED  
UNLIMITED DISTRIBUTION  
Polyurethanes  
Water vapor transport  
Water interactions  
Key Words

Army Materials and Mechanics Research Center,  
Watertown, Massachusetts 02172  
INTERACTIONS OF WATER WITH HYDROPHILIC POLYETHER POLYURETHANES -  
Joyce L. Illinger  
Technical Report AMMRC TR 82-39, June 1982, 130 pp.  
Illustrations, D/A Project 111611024H42

Two series of polyurethanes based on MDI, butanediol and several block copolymer polyethers with varying proportions of poly(ethyleneoxide) PEO and poly(propyleneoxide) PPO have been synthesized. All these materials are tough film forming elastomers of approximately same molecular weight. At constant hard block composition and decreasing amounts of PEO or PPO, the polymer soft segment content decreases. Amounts of water uptake increase as temperature decreases. Decrease in water uptake is most marked under immersion conditions or when sorption isotherm is measured at saturation conditions. However, trends are the same for both situations. When the hard block composition is varied a similar decrease in water uptake with increase in hard segment composition is seen, though not so marked. The sorption isotherms are surprisingly simple concave upward curves which rise very steeply at saturation. Analysis of the data on the basis of moles of water per ED unit indicates influence of compositional variations on the sorption isotherms and shows that saturation water concentrations are not related in a simple manner to PEO concentration. The diffusion coefficient, D, for water through these polymers decreases with increasing water concentration in the polymer and with decreasing temperature. Ethylene oxide content and hard segment content also affect the concentration dependence of D. Cluster function, size and number show very different behavior with water concentration from the pure propylene oxide soft segment polymer through block copolymer soft segment polymers to the ethylene oxide soft segment polymer. Scanning calorimetry from 150° to 323°K was performed on these sets of polymers. The polymer samples with fixed amount of added water were equilibrated to 10% intervals from 273° to 323°K. As T<sub>g</sub> was lowered the water melting endotherm diminished in size indicating that more water was bound to the polymer. The polymer soft segment T<sub>g</sub> at the T<sub>g</sub> was close to that of dry polymer but decreased by as much as 40° with increasing T<sub>g</sub> in certain samples. Values of T<sub>g</sub> correlate with amount of bound water estimated from DSC endotherm rather than with total amount of water added to the polymer. The results could be accounted for in terms of the standard free volume theory of diluent depression of T<sub>g</sub>, but T<sub>g</sub> depression in the PEO polymer is larger than expected from these calculations, suggesting that there are additional effects due to water polymer interactions.



**LATE  
LME**