

AD-A119 343

NAVAL RESEARCH LAB WASHINGTON DC
EFFICIENT ELASTIC DESIGN OF SMALL FOUNDATIONS. (U)
SEP 82 G J O'HARA, P F CUNNIFF
NRL-MR-4886

F/6 12/1

UNCLASSIFIED

NL

1 of 1

AD-A

1982

END

DATE

FILED

10-82

DTIC

AD A119343

SECURITY CLASSIFICATION OF THIS PAGE (When Data Entered)

| REPORT DOCUMENTATION PAGE | | READ INSTRUCTIONS BEFORE COMPLETING FORM |
|---|--|---|
| 1. REPORT NUMBER NRL Memorandum Report 4886 | 2. GOVT ACCESSION NO. AD-A119343 | 3. RECIPIENT'S CATALOG NUMBER |
| 4. TITLE (and Subtitle) EFFICIENT ELASTIC DESIGN OF SMALL FOUNDATIONS | 5. TYPE OF REPORT & PERIOD COVERED Interim report on a continuing NRL problem | |
| | 6. PERFORMING ORG. REPORT NUMBER | |
| 7. AUTHOR(s) George J. O'Hara and Patrick F. Cunniff | 8. CONTRACT OR GRANT NUMBER(s) | |
| 9. PERFORMING ORGANIZATION NAME AND ADDRESS Naval Research Laboratory Washington, D.C. 20375 | 10. PROGRAM ELEMENT PROJECT, TASK AREA & WORK UNIT NUMBERS SF 43-400-001 DTNSRDC 23102 58-1345-00 | |
| 11. CONTROLLING OFFICE NAME AND ADDRESS | 12. REPORT DATE September 13, 1982 | |
| | 13. NUMBER OF PAGES 12 | |
| 14. MONITORING AGENCY NAME & ADDRESS (if different from Controlling Office) | 15. SECURITY CLASS. (of this report) UNCLASSIFIED | |
| | 15a. DECLASSIFICATION/DOWNGRADING SCHEDULE | |
| 16. DISTRIBUTION STATEMENT (of this Report) Approved for public release; distribution unlimited. | | |
| 17. DISTRIBUTION STATEMENT (of the abstract entered in Block 20, if different from Report) | | |
| 18. SUPPLEMENTARY NOTES | | |
| 19. KEY WORDS (Continue on reverse side if necessary and identify by block number) Foundation design Shipboard shock Dynamic design | | |
| 20. ABSTRACT (Continue on reverse side if necessary and identify by block number) An elastic design analysis method is presented for small foundations which utilizes an energy criteria. It provides a direct approach for calculating allowable loads and for estimating the design efficiency of the resulting structure. The method has the advantage of circumventing the standard method for single degree of freedom systems in first calculating the fixed base frequency, utilizing shock design spectra, and equivalent static load analyses. A sample problem is presented that shows how to establish maximum allowable equipment weight for a shock. The results are worked up in some detail to show the ease of application of this method. | | |

DD FORM 1 JAN 73 1473

EDITION OF 1 NOV 65 IS OBSOLETE
S/N 0102-014-6601

SECURITY CLASSIFICATION OF THIS PAGE (When Data Entered)

CONTENTS

| | |
|--|----|
| INTRODUCTION | 1 |
| ELASTIC DESIGN CRITERIA | 1 |
| ELASTIC FAILURE CRITERIA | 2 |
| EXAMPLE PROBLEM | 3 |
| Energy Storage Capacity | 5 |
| ELASTIC DESIGN REQUIREMENTS | 6 |
| Bending Energy Only | 6 |
| Bending and Shear Energy | 7 |
| Effective Design Velocities, V_d | 7 |
| Frequencies | 7 |
| Deflections | 8 |
| Efficiency Factor | 8 |
| RESULTS | 8 |
| SUMMARY | 10 |
| REFERENCE | 10 |

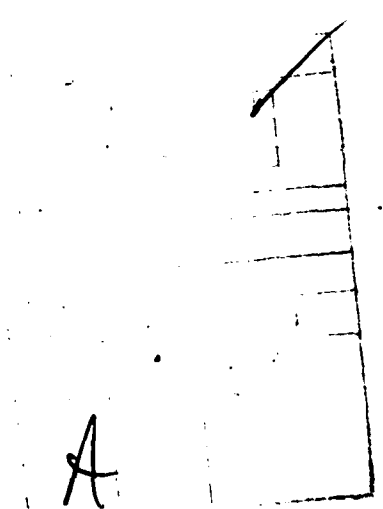

EFFICIENT ELASTIC DESIGN OF SMALL FOUNDATIONS

INTRODUCTION

For some years designers of small foundations for shipboard equipment have used a technique similar to the Navy's Dynamic Design Analysis Method (DDAM) to size them. Normally, a Single Degree of Freedom (SDOF) system is used to represent the equipment foundation structure, its fixed base frequency calculated, the effective mass estimated and some shock design spectra utilized.

Since the assumption of a SDOF system is equivalent to saying that the static and dynamic stress and deflection patterns are the same, then a direct approach taking advantage of this can lead to an efficient design method which utilizes energy criteria. Approximations in the Rayleigh sense to the frequency and deflection of the structure are easily available after the design is complete. Since these are not needed during the actual analysis phase, less time is required for the design.

For the purposes of this report and its sample calculations the designs are based upon the following hypothetical description of the shock environment:

"The equipment foundation system shall be designed to withstand elastically the lesser of a 250-g equivalent static acceleration or a shock spectrum pseudo design velocity (V_d) of 8 ft/sec."

ELASTIC DESIGN CRITERIA

Consider a SDOF system to be attached to a base as in Fig. 1. Let \bar{w} be the weight of the equipment and an assigned portion of the foundation weight. From the environmental description the foundation needs to withstand the lesser of 250 g's or a pseudo velocity [$V = X2\pi f$] of 8 ft/sec where X = relative displacement, f = frequency in Hz. The 250-g design check is straight forward. The energy stored in the spring under the pseudo velocity description can be calculated by noting that the spring stiffness (K) can be expressed as a function of the load \bar{w} and the resulting frequency of the structure f .

$$U_r = \frac{1}{2} KX^2 = \frac{1}{2} \frac{\bar{w}}{g} [2\pi f]^2 X^2 = \frac{1}{2} \frac{\bar{w}}{g} V^2. \quad (1)$$

If U_f is the energy storage capacity of the foundation, then the failure criterion becomes:

$$U_r \leq U_f. \quad (2)$$

That is, if the energy storage capacity is greater than or equal to the actual energy stored in the foundation due to the shock input, the structure will survive.

Suppose the foundation consists of a beam that is subjected to a combination of bending, shear, and direct (axial) loads. The energy absorbed by the beam for each type of load is represented as follows:

$$\text{Bending Energy} = U_b = \int_0^L \frac{M^2 dx}{2EI} \quad (3)$$

$$\text{Shear Energy} = U_s = \int_0^L \frac{\alpha S^2 dx}{2AG} \quad (4)$$

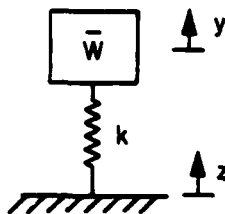

Fig. 1 - Single degree of freedom system

$$x = y - z$$

$$\text{Direct Energy} = U_d = \int_0^L \frac{P^2 dx}{2AE} \quad (5)$$

where M = bending moment, S = shear, P = axial force, E = Young's modulus, I = moment of inertia, A = cross-sectional area, G = shear modulus, α = ratio of the total cross-sectional area of the beam to the web area, and L = length of the beam. The total available storage energy is

$$U_t = U_b + U_s + U_d.$$

In the example problem developed in this report, only U_b and U_s will be present, so that

$$U_t = U_b + U_s. \quad (6)$$

It is also noted that Eq. (4) provides shear energy that closely follows a theory illustrated by Timoshenko (1).

ELASTIC FAILURE CRITERIA

Before applying the elastic energy method to a specific example, the elastic failure criteria are first reviewed and summarized for future application.

Consider the typical 10 WF 25 structural member whose cross-section is shown in Fig. 2. If such a wide flange member is subjected to bending and shear, the junction of the web and flange labeled point 1 in Fig. 2 experiences a combined stress effect that may produce the first yielding at this point. The maximum shearing stress is found from elementary strength of materials to be

$$\tau_{\max} = \sqrt{\left(\frac{\sigma_b}{2}\right)^2 + \tau_{xy}^2} \quad (7)$$

and the maximum tensile/compressive stress to be

$$\sigma_m = \frac{\sigma_b}{2} + \tau_{\max}. \quad (8)$$

The shear stress is given by

$$\tau_{xy} = \frac{SQ}{Ib} \quad (9)$$

where Q represents the planar moment of partial area of the section above the layer at which the shearing stress is being computed, and b equals the section width at the neutral axis.

The center of the web labeled point 2 in Fig. 2 is a second point where yielding in shear may begin in the beam. Now Q in Eq. (9) becomes the planar moment of area for one-half of the beam cross-section about the neutral axis.

Finally, point 3 in Fig. 2 represents the point of bending stress at the beam's outer fibers where yielding might commence. Here the bending stress is given by

$$\sigma = \frac{Mc}{I} \quad (10)$$

where c = distance from the neutral axis to the outer fiber.

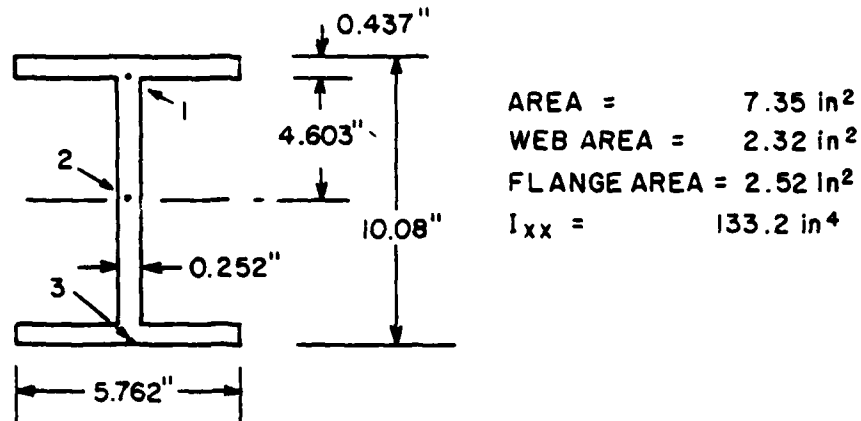

Fig. 2 - 10 WF 25 beam properties

Consider the following notation to represent the above conditions for yielding to occur:

- $\psi(1)$ = yielding under combined stress at the web flange intersection
- $\psi(2)$ = yielding in shear at the web centerline
- $\psi(3)$ = yielding in bending at the outer fibers.

In order for the structure to remain elastic, the design load is based on the smallest loading that produces any of the above yielding conditions. For example, $F(c)(1)$ represents the load that produces failure criteria 1, $\psi(1)$. Generally we would expect $\psi(1)$ to control in most cases of heavy shear. If this condition were overlooked in the analysis, then $\psi(2)$ would control in most cases of heavy shear. We call this load $F(c)(2)$ which corresponds to the shear failure criteria $\psi(2)$. Finally, $F(c)(3)$ refers to the case where bending stresses are pronounced, as in the case of beams with large length to depth ratios, so that the bending stress criteria $\psi(3)$ will probably control the design.

EXAMPLE PROBLEM

Consider the two propped cantilever beams in Fig. 3 to form the foundation for a rigidly attached piece of equipment. The beams are assumed to be 10 WF 25's and to equally share the load in vertical shock. It is also assumed that the equipment does not absorb or store potential energy. The material is steel with a tensile yield point of 50 ksi and a shear yield point of 25 ksi. The problem is to find the carrying capacity of these beams.

Figure 4 is a model of one of the propped cantilever beams in which loads w are acting at the points of attachment between the equipment, whose total weight equals $4w$, and the foundation. Replace each equipment load w by P as shown in the loading diagram in Fig. 5, where P represents the maximum allowable force that the foundation can withstand for elastic response to be maintained under shock loading. The AISC manual or other standard reference on statically indeterminate beams is useful for establishing the shear and moment diagrams that are shown in Figs. 6 and 7, respectively. These diagrams are those which would be present if the principal deflection pattern was caused by bending moment. They would be slightly different accounting for the additional shearing effects. However, this is a second order effect on the calculated value of the energy storage capacity. The shear and moment diagrams reveal that both the maximum shear and maximum moment occur at the built-in

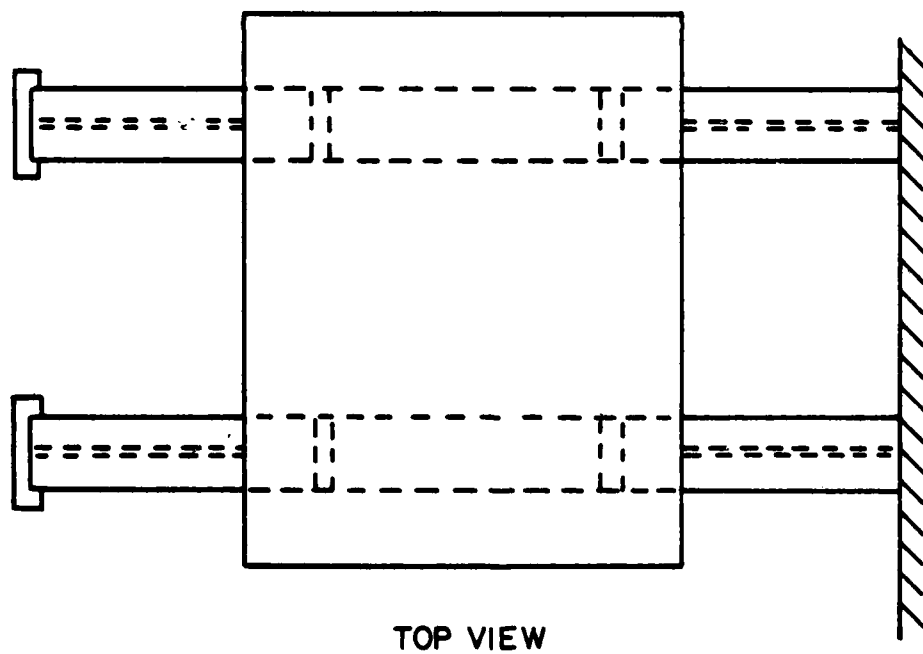
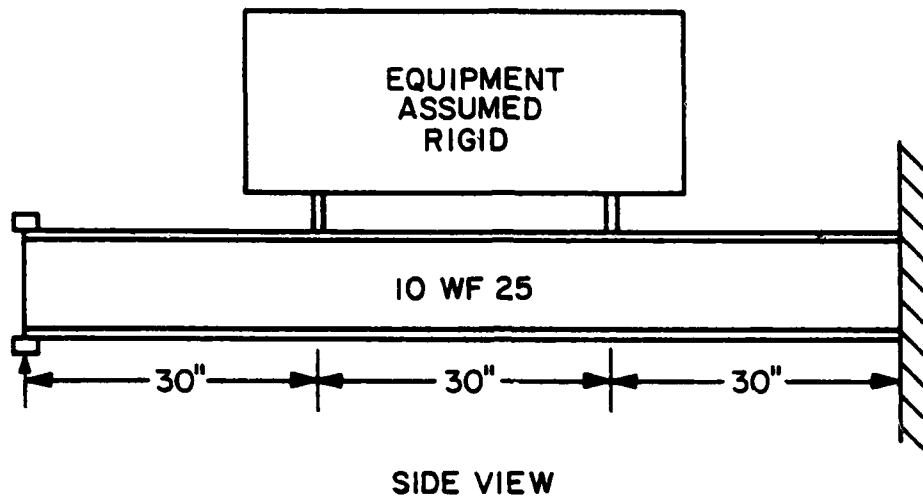

Fig. 3 - Equipment-Foundation Combination

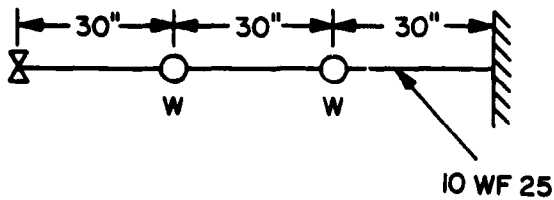

Fig. 4 - Supported cantilever

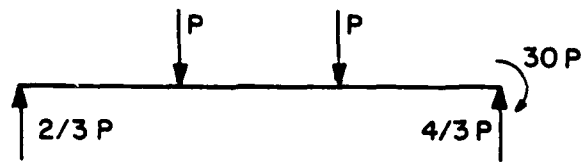

Fig. 5 - Loading diagram

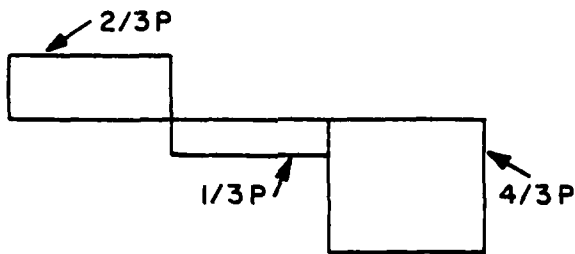

Fig. 6 - Shear diagram

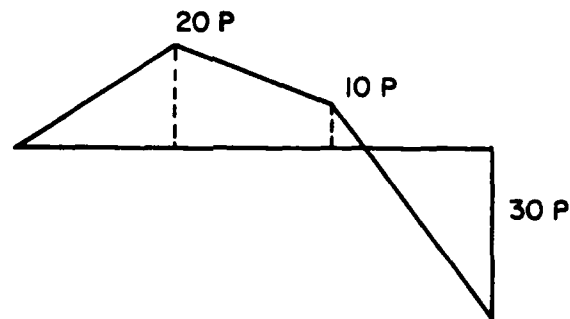

Fig. 7 - Moment diagram

end. Therefore, at the built-in end the first step in the solution is to examine the three locations on the beam cross section where yielding might occur. At the juncture of the flange and web, Eq. (7) establishes a value of $P = 35,310$ lb for yielding in shear; Eq. (8) gives $P = 40,770$ lb for yielding in direct stress; Eq. (9) gives $P = 42,500$ lb for yielding in shear at the centerline of the web; and Eq. (10) gives $P = 44,050$ lb for yielding in tension or compression at the outer fibers of the flange.

In summary then, the following yielding conditions hold for the three locations of the beam cross-section at the built-in end of the propped beam:

$$\psi(1) = 35,310 \text{ lb} = F(c)(1)$$

$$\psi(2) = 42,500 \text{ lb} = F(c)(2)$$

$$\psi(3) = 44,050 \text{ lb} = F(c)(3).$$

Since both values exceed $F(c)(1)$ we could eliminate $F(c)(2)$ and $F(c)(3)$. It will be instructive, however, to include results for these loads as well, and to look at the effects of such analyses since these loads may cause some plastic action.

Energy Storage Capacity

The next step in the analysis is to calculate the energy storage capacity of the foundation by means of Eqs. (3) and (4) or directly from the shear and moment diagrams, i.e., by taking the moment of the shear and moment diagrams, properly scaled, about their respective base lines. In either case we obtain the following results:

$$U_s = \frac{P^2}{795,400} \quad (11)$$

and

$$U_b = \frac{P^2}{444,000} \quad (12)$$

Substituting into Eq. (6) yields

$$U_f = \frac{P^2}{284,900} \quad (13)$$

Assume that one-third of the 187.5 lb propped beam is distributed to each mass load w shown in Fig. 4, [i.e., $w_f = 187.5/3 = 62.5$ lb] and that the remaining one-third of the propped beam weight is distributed to the foundation support. Thus, for the single propped beam,

$$\bar{w} = 2w + 2w_f = 2w + 125$$

Substitute into Eq. (1).

$$U_f = \frac{(2w + 2w_f)}{2g} V^2 = \frac{(w + w_f)}{g} V^2 \quad (14)$$

We shall consider the case where $U_r = U_f$ and where $V = 96$ in./sec. This leads to the following expression for the carried load w :

$$w = \frac{U_f}{23.85} - 62.5 \quad (15)$$

ELASTIC DESIGN REQUIREMENTS

Recall that the maximum allowable loads applied to the beam consist of two forces, each of magnitude P . Consequently, the relationship between the total force acting on the beam under shock conditions and the corresponding SDOF system in Fig. 1 is given by

$$2P = \bar{w}N \quad (16)$$

where N = design load in g's. Now

$$2P = (2w + 2w_f)N$$

or

$$w = \frac{P}{N} - w_f \quad (17)$$

For the case of $N = 250$ -g's and a maximum allowable $P = 35,310$ lb,

$$w = \frac{35,310}{250} - 62.5 = 78.7 \text{ lb}$$

The total weight that may be carried by a beam is $2w = 157.4$ lb. It is interesting to note that in this case the ratio of the foundation weight (187.5 lb) to the carried weight (157.4 lb) equals 1.191. The foundation is heavier than the equipment.

Let us now return to Eq. (15) to obtain w for an 8 ft/sec design level. It is instructive to consider the foundation storage capacity to include only the bending energy, and then to examine the case in which both the bending energy and shear energy are included.

Bending Energy Only

Substitute $P = 35,310$ lb into Eq. (12) so that

$$U_b = \frac{(35,310)^2}{444,000} = 2808 \text{ in.-lb}$$

Considering this energy for U_f in Eq. (15) leads to

$$w = \frac{2808}{23.85} - 62.5 = 55.2 \text{ lb}$$

Therefore, $2w = 110.4 \text{ lb}$ and the ratio of the foundation weight to the carried weight is 1.698. Note that the number of g 's that this design calls for is

$$N = \frac{P}{w + w_f} = \frac{35,310}{55.2 + 62.5} = 300 \text{ g.}$$

However, this exceeds the design level of 250-g. A designer might be tempted to conclude that since the 250-g design produced the greater carried weight, the analysis is complete. However, this conclusion is not valid if the shear energy is included in the foundation storage capacity.

Bending and Shear Energy

From Eq. (13),

$$U_f = U_s = \frac{(35,310)^2}{284,900} = 4376 \text{ in.-lb}$$

so that

$$w = \frac{4376}{23.85} - 62.5 = 121.0 \text{ lb}$$

The total carried weight now equals 242 lb and the ratio of the foundation weight to the carried weight equals 0.775. The foundation weight is now less than the carried weight. The "g" design value is

$$N = \frac{53,310}{121 + 62.5} = 192.4 \text{ g's.}$$

Note that accounting for the additional shear energy made a dramatic improvement in the permitted load. Yet absolute elastic response is still retained.

Effective Design Velocities, V_d

Equation (14) is now rearranged to find the effective design velocity,

$$V_d = \frac{1}{12} \sqrt{\frac{gU}{w + w_f}} \text{ (ft/sec),} \quad (18)$$

where U is the energy storage capacity of the design. In the case of the 250-g design load, $w = 78.7 \text{ lb}$. Using $U = 4376 \text{ in.-lb}$, Eq. (18) yields $V_d = 9.12 \text{ ft/sec}$. For the case in which only the bending energy was used to calculate $w = 55.2 \text{ lb}$, the $V_d = 9.99 \text{ ft/sec}$.

Note that in each case the effective design velocity is greater than the desired design velocity of 8 ft/sec, even though this was not intended. This is, of course, reflected in the lower weight w in each case.

Frequencies

Although not required by the Energy Design Method, an estimate of the response frequency is readily made in the Rayleigh sense by recalling that in the case of a SDOF system, the relationship between its acceleration amplitude and its velocity amplitude is

$$\omega = 2\pi f = \frac{a}{V}. \quad (19)$$

But

$$a = Ng \text{ and } V = V_d.$$

Therefore, an expression for the approximate frequency is:

$$f = 386.4 \frac{N}{24\pi V_d} \quad (20)$$

since v_d has units of ft/sec. This leads to the following results:

$$\text{For the 250-g design: } N = 250, \quad V_d = 9.12 \text{ ft/sec. } f = 140.5 \text{ Hz}$$

$$\text{For the } U_b \text{ design: } N = 300, \quad V_d = 9.99 \text{ ft/sec. } f = 153.9 \text{ Hz}$$

$$\text{For the } U_t \text{ design: } N = 192.4, \quad V_d = 8.00 \text{ ft/sec. } f = 123.3 \text{ Hz}$$

Deflections

It is interesting to calculate the "average" deflection of both masses w in Fig. 4 by extending Eq. (19) for displacement amplitudes and velocity amplitudes, i.e.,

$$\omega = 2\pi f = \frac{V}{x}$$

or

$$x = \frac{12 V_d}{2\pi f} \quad (21)$$

Letting the environmental $V_d = 8$ ft/sec for each of the three cases considered, then the following results are obtained:

$$\text{For the 250-g design: } x = 0.109 \text{ in.}$$

$$\text{For the } U_b \text{ design: } x = 0.099 \text{ in.}$$

$$\text{For the } U_t \text{ design: } x = 0.124 \text{ in.}$$

Efficiency Factor

It is desirable to be able to measure the efficiency of a design. To that end, consider the following equation that measures the efficiency in terms of energy:

$$\text{Efficiency Factor} = \sqrt{\frac{\text{actual energy absorbed}}{\text{total energy capacity}}} \quad (22)$$

RESULTS

The results for the Elastic Design Method using $F(c)(1)$ are summarized in Table I using the following notation:

- $F(c)(1)$ — the design category for absolute elastic behavior
- WGT — the total carried weight (lb) by one propped beam
- % — the percent of the foundation weight to carried weight
- N — the g-design value
- V_d — the effective velocity design value for the configuration in ft/sec based upon the structure's ability to absorb energy
- FREQ — the Rayleigh estimate for the fixed base frequency (Hz)
- DEFL — the deflection (in.) for an 8 ft/sec design.

Table I – Summary of the Elastic Design Method for $F(c)(1)$

$$P = 35,310 \text{ lb} \quad U_b = 2808 \text{ in.-lb} \quad U_t = 4376 \text{ in.-lb}$$

| $F(c)(1)$ | WGT (lb) | % | N(g) | V_d (ft/s) | FREQ (Hz) | DEFL (in.) |
|----------------|----------|-------|-------|--------------|-----------|------------|
| 250 g Design | 157.4 | 119.1 | 250.0 | 9.12 | 140.5 | 0.109 |
| Bending Energy | 110.4 | 169.8 | 300.0 | 9.99 | 153.9 | 0.099 |
| Total Energy | 242.0 | 77.5 | 192.4 | 8.00 | 123.3 | 0.124 |

The expressions in the first column indicate the method by which WGT was computed. It is apparent from the data that the inclusion of shear energy in the analysis made an appreciable difference in the results.

In the three designs considered in Table I the carried weight of 121.0 lbs of course utilizes the entire elastic capacity. It then has an efficiency of 100%. The others have efficiency factors of 87.7% ($w = 78.7$ lbs) and 80.1% ($w = 55.2$ lbs), respectively. Note that these values are the ratios of the respective V_d 's.

While the results in Table I complete the analysis of the foundation by the Elastic Design Method, it is instructive to examine the case for both $F(c)(2)$ and $F(c)(3)$, even though they are not the correct failure criteria for the example problem under investigation. These results are summarized in Tables II and III. Of course, any carried weight WGT that exceeds 242 lb, which is shown in Table I for the total energy condition, implies that plastic yielding must occur. For example, a design weight of 406.6 lb is shown in Table II using the total available energy of 6340 in.-lb. A similar result occurs in Table III when the total available energy was used in the calculations so that $\text{WGT} = 446.2$ lb.

A comparison of the results is also made between the data generated in Table II and the corresponding N and V_d levels required for elastic behavior. For example, in Table II the bending energy approach shows $N = 249.1$ g's and $V_d = 9.99$ ft/sec. Since these values are based upon $P = 42,500$ lb, we can scale these results by the ratio of $(35,310/42,500)$ to show the required levels so as not to exceed the elastic limit at the location of the beam under investigation. The results for this point of view are summarized in Tables IV and V. In order for the yielding in shear at the web centerline of the beam to remain elastic, the g-design level should be reduced from 249.1 to 207.0 and the effective velocity design level from 9.99 ft/sec to 8.30 ft/sec in order to carry the $\text{WGT} = 216.2$ lb.

Table II – Summary of the Elastic Design Method for $F(c)(2)$

$$P = 42,500 \text{ lb} \quad U_b = 4068 \text{ in.-lb} \quad U_t = 6340 \text{ in.-lb}$$

| $F(c)(2)$ | WGT (lb) | % | N(g) | V_d (ft/s) | FREQ (Hz) | DEFL (in.) |
|----------------|----------|------|-------|--------------|-----------|------------|
| 250 g Design | 215.0 | 87.2 | 250.0 | 10.00 | 128.1 | 0.119 |
| Bending Energy | 216.2 | 86.7 | 249.1 | 9.99 | 127.8 | 0.120 |
| Total Energy | 406.6 | 46.1 | 159.9 | 8.00 | 102.4 | 0.149 |

Table III — Summary of the Elastic Design Method for $F(c)(3)$

$$P = 44,050 \text{ lb} \quad U_b = 4370 \text{ in.-lb} \quad U_t = 6811 \text{ in.-lb}$$

| $F(c)(1)$ | WGT (lb) | % | N(g) | V_d (ft/s) | FREQ (Hz) | DEFL (in.) |
|----------------|----------|------|-------|--------------|-----------|------------|
| 250 g Design | 227.4 | 82.5 | 250.0 | 10.20 | 125.6 | 0.122 |
| Bending Energy | 241.4 | 77.7 | 240.4 | 9.99 | 123.3 | 0.124 |
| Total Energy | 446.2 | 42.0 | 154.2 | 8.00 | 98.8 | 0.155 |

Table IV — Comparison of Results of Table II with the Maximum Elastic Load

| $F(c)(2)$ | WGT (lb) | N(g) Table II | N(g) Elastic Limit | V_d (ft/sec) Table II | V_d (ft/sec) Elastic Limit |
|----------------|----------|------------------|-----------------------|----------------------------|---------------------------------|
| 250 g Design | 215.0 | 250.0 | 207.7 | 10.00 | 8.31 |
| Bending Energy | 216.2 | 249.1 | 207.0 | 9.99 | 8.30 |
| Total Energy | 406.6 | 159.9 | 132.8 | 8.00 | 6.65 |

Table V — Comparison of Results of Table III with the Maximum Elastic Load

| $F(c)(3)$ | WGT (lb) | N(g) Table III | N(g) Elastic Limit | V_d (ft/s) Table III | V_d (ft/sec) Elastic Limit |
|----------------|----------|-------------------|-----------------------|---------------------------|---------------------------------|
| 250 g Design | 227.4 | 250.0 | 200.4 | 10.20 | 8.18 |
| Bending Energy | 241.4 | 240.4 | 192.7 | 9.99 | 8.01 |
| Total Energy | 446.2 | 154.2 | 123.6 | 8.00 | 6.41 |

SUMMARY

The elastic design method has been developed as a practical method for designing lightweight foundations for equipment in a shock environment. The method is simple to apply to foundations that are assumed to act as SDOF systems. The example problem that was investigated clearly demonstrated the importance of analyzing the structure where yielding will first occur and the important contribution that the shear energy makes in establishing the allowable carried weight by the foundation. It has also been demonstrated that approximate values for the fixed base frequencies, effective design velocities, and deflections are readily obtained by the method of analysis.

An interesting feature is the ability to calculate a number for the efficiency of the design. It should be possible in the interest of producing lighter foundations to require an efficiency greater than some number, say 96% or so.

REFERENCE

1. Timoshenko, S. "Strength of Materials." D. Van Nostrand, 2nd Edition, 1940, pg. 170.