

AD A119389

DTIC FILE COPY

TECHNICAL JOURNAL

TN NO: N-1641

①

TITLE: OPERATING AND MAINTENANCE EXPERIENCE WITH A 6-kW WIND ENERGY CONVERSION SYSTEM AT NAVAL STATION, TREASURE ISLAND, CALIFORNIA

AUTHOR: D. Pal

DATE: July 1982

SPONSOR: Naval Sea Systems Command

PROGRAM NO: S0829-01-561

NOTE

NAVAL CIVIL ENGINEERING LABORATORY
PORT HUENEME, CALIFORNIA 93043

Approved for public release; distribution unlimited.

DTIC
SEP 20 1982

82 09 20 142 A

METRIC CONVERSION FACTORS

Approximate Conversions to Metric Measures

Symbol	When You Know	Multiply by	To Find	Symbol
		LENGTH		
in	inches	*2.5	centimeters	cm
ft	feet	30	centimeters	cm
yd	yards	0.9	meters	m
mi	miles	1.6	kilometers	km
		AREA		
in ²	square inches	6.5	square centimeters	cm ²
ft ²	square feet	0.09	square meters	m ²
yd ²	square yards	0.8	square meters	m ²
mi ²	square miles	2.6	square kilometers	km ²
	acres	0.4	hectares	ha
		MASS (weight)		
oz	ounces	28	grams	g
lb	pounds	0.45	kilograms	kg
	short tons (2,000 lb)	0.9	tonnes	t
		VOLUME		
1/2 p	teaspoons	5	milliliters	ml
1 p	tablespoons	15	milliliters	ml
fl oz	fluid ounces	30	milliliters	ml
c	cup	0.24	liters	l
p	pint	0.47	liters	l
qt	quart	0.96	liters	l
gal	gallon	3.8	liters	l
ft ³	cubic feet	0.03	cubic meters	m ³
yd ³	cubic yards	0.76	cubic meters	m ³
		TEMPERATURE (exact)		
°F	Fahrenheit temperature	5/9 (after subtracting 32)	Celsius temperature	°C

Approximate Conversions from Metric Measures

Symbol	When You Know	Multiply by	To Find	Symbol
		LENGTH		
mm	millimeters	0.04	inches	in
cm	centimeters	0.4	inches	in
m	meters	3.3	feet	ft
m	meters	1.1	yards	yd
km	kilometers	0.6	miles	mi
		AREA		
cm ²	square centimeters	0.16	square inches	in ²
m ²	square meters	1.2	square yards	yd ²
km ²	square kilometers	0.4	square miles	mi ²
ha	hectares (10,000 m ²)	2.5	acres	
		MASS (weight)		
g	grams	0.035	ounces	oz
kg	kilograms	2.2	pounds	lb
t	tonnes (1,000 kg)	1.1	short tons	
		VOLUME		
ml	milliliters	0.03	fluid ounces	fl oz
l	liters	2.1	pints	pt
l	liters	1.06	quarts	qt
l	liters	0.26	gallons	gal
m ³	cubic meters	36	cubic feet	ft ³
m ³	cubic meters	1.3	cubic yards	yd ³
		TEMPERATURE (exact)		
°C	Celsius temperature	9/5 (then add 32)	Fahrenheit temperature	°F

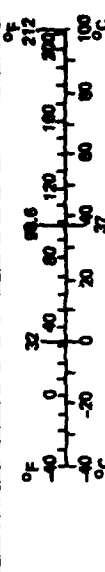
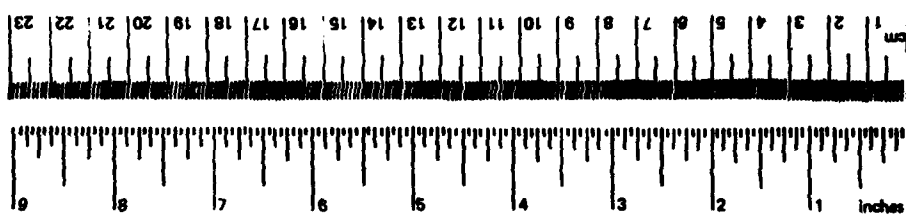

* 1 in. = 2.54 (exactly). For other exact conversions and more detailed tables, see NBS Misc. Publ. 286, Units of Weights and Measures, Price \$2.25, SD Catalog No. C13.10.286.

Unclassified

SECURITY CLASSIFICATION OF THIS PAGE (When Data Entered)

REPORT DOCUMENTATION PAGE		READ INSTRUCTIONS BEFORE COMPLETING FORM
1. REPORT NUMBER TN-1641	2. GOVT ACCESSION NO. DN787040 AD-1119389	3. RECIPIENT'S CATALOG NUMBER
4. TITLE (and Subtitle) OPERATING AND MAINTENANCE EXPERIENCE WITH A 6-kW WIND ENERGY CONVERSION SYSTEM AT NAVAL STATION, TREASURE ISLAND, CALIFORNIA		5. TYPE OF REPORT & PERIOD COVERED Not final; Sep 1979 - Jun 1981
7. AUTHOR(s) D. Pal		6. PERFORMING ORG. REPORT NUMBER
9. PERFORMING ORGANIZATION NAME AND ADDRESS NAVAL CIVIL ENGINEERING LABORATORY Port Huene, California 93043		8. CONTRACT OR GRANT NUMBER(s)
11. CONTROLLING OFFICE NAME AND ADDRESS Naval Sea Systems Command Washington, DC 20362		10. PROGRAM ELEMENT, PROJECT, TASK AREA & WORK UNIT NUMBERS 63724N; S0829-01-561
14. MONITORING AGENCY NAME & ADDRESS (if different from Controlling Office)		12. REPORT DATE July 1982
		13. NUMBER OF PAGES 49
		15. SECURITY CLASS. (of this report) Unclassified
16. DISTRIBUTION STATEMENT (of this Report) Approved for public release; distribution unlimited.		15a. DECLASSIFICATION DOWNGRADING SCHEDULE
17. DISTRIBUTION STATEMENT (of the abstract entered in Block 20, if different from Report)		Accession For GRI&I <input checked="" type="checkbox"/> AB <input type="checkbox"/> Unseed <input type="checkbox"/> Classification
18. SUPPLEMENTARY NOTES		Distribution/ Availability Codes Avail and/or Special
19. KEY WORDS (Continue on reverse side if necessary and identify by block number) Wind power, wind turbine generators, inverters, wind energy conversion systems, renewable energy sources.		<i>A</i>
20. ABSTRACT (Continue on reverse side if necessary and identify by block number) This report describes in detail the experience gained and lessons learned from the 6-kW grid-integrated Wind Energy Conversion System (WECS) demonstration at Naval Station, Treasure Island, San Francisco Bay. The objective of this demonstration was to develop operating experience and maintenance information on the 6-kW WECS using a combination of permanent magnet alternator with a line commutated synchronous inverter. The on-site (continued)		



Unclassified

SECURITY CLASSIFICATION OF THIS PAGE (When Data Entered)

Unclassified

SECURITY CLASSIFICATION OF THIS PAGE(When Data Entered)

20. Continued

measurements conducted during the demonstration indicate that the WECS site has annual average windspeeds of about 8 to 10 mph. The test results to date indicate a satisfactory performance of the WECS except for two failures involving arcing at the electrical terminals located on the yaw shaft. Due to wind characteristics encountered at the site, the performance data collected to date are at windspeeds of 20 mph or lower. For evaluating the WECS performance at all windspeeds, location at a windier site with annual average windspeeds of 14 mph or higher is recommended.

Library Card

Naval Civil Engineering Laboratory
OPERATING AND MAINTENANCE EXPERIENCE WITH A
6-kW WIND ENERGY CONVERSION SYSTEM AT NAVAL
STATION, TREASURE ISLAND, CALIFORNIA, by D. Pal
TN-1641 49 pp illus July 1982 Unclassified

1. Wind Energy Conversion System 2. Energy conservation I. S0829-01-561

This report describes in detail the experience gained and lessons learned from the 6-kW grid-integrated Wind Energy Conversion System (WECS) demonstration at Naval Station, Treasure Island, San Francisco Bay. The objective of this demonstration was to develop operating experience and maintenance information on the 6-kW WECS using a combination of permanent magnet alternator with a line commutated synchronous inverter. The on-site measurements conducted during the demonstration indicate that the WECS site has annual average windspeeds of about 8 to 10 mph. The test results to date indicate a satisfactory performance of the WECS except for two failures involving arcing at the electrical terminals located on the yaw shaft. Due to wind characteristics encountered at the site, the performance data collected to date are at windspeeds of 20 mph or lower. For evaluating the WECS performance at all windspeeds, location at a windier site with annual average windspeeds of 14 mph or higher is recommended.

Unclassified

SECURITY CLASSIFICATION OF THIS PAGE(When Data Entered)

CONTENTS

	Page
INTRODUCTION	1
SYSTEM DESCRIPTION	2
TEST SITE, CONDITIONS, AND OBJECTIVES	4
INSTRUMENTATION	4
Anemometer	4
Indicator	4
Autodata Nine Data Acquisition System With Averaging Option	5
RS 232 Tape Recorder	5
Wattmeters	5
TEST RESULTS	5
DISCUSSION	7
Climatological Data	7
Operating Data	7
Maintenance Data	10
Reliability, Maintainability, and Availability Data	12
Power Output Data	13
Summary of Performance	14
CONCLUSIONS	14
RECOMMENDATIONS	15
APPENDIXES	
A - Line-Commutated or Synchronous Inversion of DC Power	27
B - Field Data Log and System Operation Records	30
C - WECS Performance Data for Rotor-1 and Rotor-2	38

INTRODUCTION

As part of the Naval Civil Engineering Laboratory's (NCEL) ongoing investigation of the application of small Wind Energy Conversion Systems (WECS) to generate electricity at Naval shore installations, a grid-integrated 6-kW commercial wind plant was installed for demonstration at the Naval Station, Treasure Island, California, in September 1979. The tests being conducted during the demonstration are designed to yield data on the following:

1. Performance of a permanent-magnet-type wind-turbine-powered generator.
2. Interfacing characteristics of, and the quality of power delivered by, a 6-kW WECS using a single-phase synchronous inverter system.
3. Any design modifications required to improve the performance, operational features, and reliability of the system.

The system chosen for the demonstration includes an upwind, horizontal-axis, three-bladed, propeller-driven, 6-kW (at 28 mph) wind turbine with a variable-pitch rotor and a three-phase permanent magnet generator (alternator). The generator incorporates a rectifier which converts the variable voltage and frequency electricity produced by the variable speed rotor to DC electricity. The rectifier's output is connected to a 7.5-kW single-phase synchronous inverter which accepts the DC power from the rectifier, converts it to 60-Hz AC power, and feeds it into the grid network.

A 6-kW WECS size was chosen for the demonstration based on the premise that such a power level corresponds approximately to the peak electrical demand of a single family residence. Currently, in most commercially available WECS, horizontal-axis rotors (propellers) are utilized to drive an electrical generator through a step-up gearbox. Several vertical-axis wind turbines are available on the market and they afford certain advantages over the more conventional horizontal systems. However, between the two basic designs, propeller systems are by far more efficient for collecting wind energy. It is because of this wide disparity in efficiency that a turbine of horizontal axis design was chosen for the demonstration at Treasure Island. The upwind version of this design was chosen, thereby eliminating movement of the rotor blades into the tower's wake.

Because of the variable nature of the wind, the rotor of a horizontal-axis wind machine without any external controls will turn at variable speed. A generator driven by such a rotor will deliver electricity with variable voltage and frequency. The constant voltage and frequency electricity can be delivered by utilizing a wind turbine with blade-pitch controlled rotors designed to operate at constant speed. However, the power, and hence the total energy output, from such a

machine will be less than that delivered by a machine incorporating variable speed propellers, especially at locations where, most of the time, the prevailing windspeed is less than the rated windspeed of the wind turbine. As this may often be the case at most Naval shore establishments, a variable speed rotor was chosen for the demonstration to maximize the energy output of the WECS.

In several preceding demonstrations of WECS conducted by NCEL, self-excited generators have been used to convert mechanical energy in the wind into electrical energy. This demonstration uses a permanent magnet generator to eliminate use of a wound rotor and brushes. Such a generator design is free from problems inherent in these components (e.g., rotor winding failure due to excessive vibration, to overheating, or fatigue; or to brush failure due to excessive wear; or to corrosion due to the marine environment). One of the most important considerations in the choice of WECS configuration is the power conditioning method to be used. Among the various systems compatible with the 6-kW wind turbine installed at Treasure Island, a line-commutated and integrated synchronous inverter system was chosen for demonstration because of its availability, relatively low cost, and higher efficiency. The wind-turbine generator is mounted on an open truss, free standing, 60-ft-high tower. This tower design, which can be mass produced, was chosen for its reasonable cost and commercial availability.

SYSTEM DESCRIPTION

The WECS chosen by NCEL for demonstration at the Naval Station, Treasure Island, consists basically of an upwind 6-kW wind turbine and a synchronous inverter, both of commercial design. The wind turbine is comprised of a three-phase AC generator driven by a three-bladed rotor 17 feet 5 inches in diameter and is mounted on an open truss, free-standing tower 60 feet in height. At the time of installation, the WECS rotor diameter was 16 feet 5 inches (Rotor-1); new blades 6 inches longer than those originally installed were incorporated into the system in early December 1980 to increase the power production from the WECS. The rated windspeed of the turbine is computed to be about 28 mph. The system is currently set up to supply power for warehouse lighting and forklift battery charging. The modified rotor (diameter 17 feet 5 inches) is referred to as Rotor-2. A schematic drawing of the WECS demonstration at the Naval Station, Treasure Island, is given in Figure 1.

The wind turbine's rotor uses laminated wooden blades without twist. The nacelle housing the rotor shaft, gearbox, and generator is free to yaw about its vertical axis as directed by the wind's force. A tail arrangement located downwind of the WECS tower was provided to maintain rotor orientation into the wind. The cut-in speed of the machine is approximately 8 mph. Once the rotor starts to turn, its rotational speed is governed by the aerodynamic forces up to the turbine's rated windspeed of 28 mph. Beyond that point a governor system increases blade pitch with increasing windspeed to control rotor rpm's. At windspeeds in excess of the 45 mph furling windspeed, the tail is automatically rotated 90 degrees, which turns the rotor completely out of the wind.

The rotor drives a 3-phase permanent magnet AC generator through a standard step-up gearbox with a gearing ratio of 4.12. The generator incorporates a rectifier which converts the variable voltage and frequency AC power produced by the variable speed rotor to DC power. At the rated windspeed, the generator is designed to deliver 6 kW of DC power at 180 volts.

The DC electricity produced by the wind-driven generator is fed into a single-phase, line-commutated synchronous inverter. The inverter converts the variable DC voltage and power electricity to AC electricity at the grid line voltage and frequency. The principle of operation of a synchronous inverter is discussed in Appendix A. As shown in the schematic of Figure 1, the inverter accepts the rectified DC output of the generator, converts it to AC, and feeds it into the existing grid lines. The load connected in the grid network receives power at the voltage and frequency fixed by the grid lines. If, at any instant, the generator produces more power than is required by the load, the excess flows into the grid network. If the generator output is less than the load requires, the difference is provided by the grid.

In regard to quality of power, there are no rigid specifications for allowable total harmonic distortion for synchronous inverters operating with WECS. However, for WECS installations with the generator impedance properly matched to the impedance of the AC line, the total harmonic distortion of the output waveform is well within the range of typical loads encountered on utility lines at military installations. Although higher order harmonics in current waveform from the inverter at Treasure Island do exist and are as high as 11% (as in the case of the third harmonic), the fundamental amplitude contributes about 98% of the total power. Windworks, Inc. has published a complete harmonic analysis of the current waveform and more detailed descriptions of the features of the synchronous inverter being employed.*

Table 1 summarizes the aforementioned characteristics of the WECS installed at the Naval Station, Treasure Island, as well as presents some additional specific details of the system. An economic analysis based upon the method given in NCEL Technical Note N-1613** was performed for the 6-kW plant, and the results are given in Table 2. The data in Table 2 compares initial capital investment costs, differences in annual operating costs for wind-generated versus diesel-generated power, and differential life cycle costs and discounted payback periods, for Treasure Island and gives other sites potentially suitable for a 6-kW WECS installation of this type. Clearly, because of its relatively low wind potential, the Treasure Island location is not economically viable for such a WECS configuration.

*Windworks, Inc. Information on Gemini synchronous inverter system. Mukwonago, Wisconsin.

**Naval Civil Engineering Laboratory. Technical Note N-1613: Wind power utilization guide, by D. Pal. Port Hueneme, Calif., Sep 1981, pp. 135-141.

TEST SITE, CONDITIONS, AND OBJECTIVES

The installation of the 6-kW WECS chosen for demonstration at the Naval Station, Treasure Island, was completed in September 1979. At the site, the prevailing wind direction is westerly, and average annual wind-speed is estimated to be 8 to 10 mph (Table 2). Therefore, the average power available in the wind per unit disk area of the rotor is 4.5 W/ft^2 and the estimated annual output of the wind plant averages 3,000 kW-hours. The plant supplies a portion of the power for warehouse lighting and forklift battery charging. The map in Figure 2 shows the location of Treasure Island in relation to the San Francisco Bay area. Figure 3 shows the location of the WECS Treasure Island in the San Francisco Bay. Figure 4 shows the WECS installation adjacent to the supply department warehouse at the Naval Station.

Since the development of small WECS is at such an early stage, the main thrust of testing conducted to date and that being conducted at the present time has been directed toward the collection of system performance, operating, and maintenance data. The various types of data being collected on a periodic basis at the WECS demonstration site can be found in the Discussion section of this document.

INSTRUMENTATION

This Section describes the data collection instruments being used in the WECS demonstration at Treasure Island. A connection diagram showing the relative location of the various instruments in the system is given in Figure 5. Various instruments are described in detail in the material that follows.

Anemometer

The anemometer being used in the demonstration is the Bendix Aerovane Wind Transmitter, Model 120. It is a dual purpose instrument for measuring both windspeed and direction.

Windspeed is measured by a three-bladed impeller fastened to the armature of a tachometer magneto located in the nose of the instrument. The voltage generated by the magneto, a function of the windspeed, is electrically transmitted to a remotely located voltmeter which is calibrated to indicate windspeed in miles per hour for visual observation.

Wind direction is measured by a streamlined vane coupled to the rotor of a type 1 HG synchro. This synchro electrically transmits the vane position to a remotely located companion synchro which moves a pointer on a wind direction dial. Windspeed and direction are displayed on the Bendix Model 135 Aerovane Indicator. This type of instrument must have a 60-Hz power supply for its operation.

Indicator

The Model 135 Bendix Aerovane Indicator being used in the demonstration is an electrical device designed to provide constant visual indication of windspeed and direction. The indicator is used in conjunction with

the transmitter which furnishes the windspeed and direction inputs. It is mounted in a rack along with several other data collection instruments as shown in Figure 6. The indicator displays windspeeds in the range from 0 to 100 mph with an accuracy of $\pm 1\%$ and a threshold of 2 mph or less, depending on the sensor. The indicator displays wind direction in the range from 0 to 360 degrees with an accuracy of ± 3 degrees and a threshold of 3 mph or less, depending on the sensor.

Following passage of the AC signal through the indicator, the signal passes through a conditioner which converts it to DC and enlarges it for use in the Autodata Nine and analog-to-digital data logger.

Autodata Nine Data Acquisition System With Averaging Option

This Autodata Nine System is an analog-to-digital data logger which has the capability of taking nearly continuous (several per second) measurements of desired phenomena on up to 256 channels and, following the conclusion of a predetermined period of time, calculating and recording the arithmetic average of the total number of measurements taken on each selected channel. Items being recorded for the demonstration at Treasure Island include speed and direction of the wind, generator output, and power supplied to the grid. Because of the random nature of wind, the windspeed, generator output, and power flow to the grid are averaged over a specified time interval, ranging from 15 minutes to 1 hour, to facilitate data analysis.

RS 232 Tape Recorder

An RS 232 tape recorder is incorporated in the System to store all collected data on magnetic tape. If desired, the data can be fed to a computer to construct plots for graphic displays.

Wattmeters

As shown in the wiring diagram (Figure 5), there are two wattmeters being employed in the demonstration at Treasure Island to collect the data specified in the test objectives. The meter in the line between the generator and the inverter measures the DC power supplied to the inverter by the generator. The meter between the inverter and the grid network measures the AC power supplied to the grid by the inverter. Both meters are watt-hour and wattmeter types utilizing Hall-effect power transducers as input elements. The watt-hour indications are based on the absolute volts and amperes. The specifications for the two wattmeters are presented in Table 3.

TEST RESULTS

Since installation in September 1979 at the Naval Station, Treasure Island, WECS performance has been generally satisfactory. Only two critical failures (system producing very little or no electrical power) due to component failure have occurred -- the first in late December 1979 and

the second in late March 1981. In both cases the failure was the result of generator output terminals being grounded through the tower. The insulation between a generator terminal and the generator body became weak due to marine salt deposition which resulted in a flashover. The generator terminal was grounded through the tower and only two, instead of three, phases were producing power, thus greatly reducing the system's generator power output.

In addition to these two critical failures, the only other technical problem encountered during the demonstration has been maintaining the synchronous inverter in a properly programmed state. Proper programming of the synchronous inverter involves setting the firing sequence of the silicon-controlled rectifiers to match the ambient wind conditions experienced at the site. When windspeeds are highly variable, maintaining the impedance of the WECS so that it is properly matched with that of the AC line is a chronic problem which must be frequently addressed.

Details of field data and WECS operation record for the period ranging from December 1979 through June 1981 are given in Appendix B. In particular the data tabulation shows the amount of AC energy into the grid and the amount of DC energy being generated by WECS. Also, the tabulated information contains average watt-hours per day being generated by WECS and the amount flowing into the AC grid, including the average efficiency of the inverter system based upon the average power level values. For reference, the test experience comments by the personnel monitoring the WECS installation at Treasure Island are also included in the table. In summary, during the period 10 December 1979 through 19 May 1980 system performance was extremely poor. As is evident from the field data log during this 162-day interval, only 5 kW-hr of AC and 112 kW-hr of DC power were produced, which corresponds to an efficiency of about 2% to 6% for the inverter. This poor system performance was due to the synchronous inverter being improperly programmed. After reprogramming of the synchronous inverter during the period 20 May through 23 May 1980, performance improved significantly.

For the period 20 May 1980 through 10 March 1981 (295 days), a total of 1,115 kW-hr of AC and 1,430 kW-hr of DC energy production were measured at the inverter and the generator output points, respectively. These energy production values correspond to annual outputs of 1,380 and 1,769 kW-hr for the two subcomponents of the WECS, respectively. The inverter efficiency during this period ranged between 75% to 81%.

At some time during the period 10 March through 13 April 1981, one of the generator terminals grounded to the tower (one of the aforementioned critical failures) and performance degraded significantly. The inverter efficiency dropped from a level between 75% to 81% down to 25%; and before the damaged generator terminal wire could be repaired on 19 May, it had dropped to less than 1%. Following repair of the system, the generator output returned to the normal level except for the inverter efficiency which ranged between 34% to 55% only. Apparently, the grounding of the generator terminals caused component failures in the inverter. In the 43-day interval from 19 May to 30 June 1981, about 172 kW-hr of AC and 340 kW-hr of DC power were measured at the generator and the inverter output points, respectively. These values reduce to annual outputs of 1,460 and 2,886 kW-hr, respectively.

DISCUSSION

This section discusses the data analysis results for the test objectives listed earlier. Because collecting data on some of the test objectives was not possible, the results of visual observations were substituted in the drawing of conclusions.

Climatological Data

Windspeed and Direction. Instantaneous readings of windspeed and direction are being made at time intervals of 0.01 second throughout the demonstration. Average values of windspeed and direction are computed over a period of 15 minutes, 1 hour, and 24 hours, respectively, using the Autodata Nine Data Acquisition System. Based upon the data analysis to date it was estimated that the annual average windspeed at the site is in the 8- to 10-mph range, with the predominant wind direction being from the West.

Ambient Air Temperature. Seasonal variation in air temperature for the San Francisco Bay area normally ranges from 40° to 80°F. This corresponds to about 8% change in air density throughout the year which is not significant enough to affect the power output computations for the machine.

Salt Concentration. No direct measurements were made to estimate salt concentration in the air. However, upon examination of the WECS tower surfaces no significant rust or corrosion were found. Hence, the corrosion potential at the site is not very severe.

Operating Data

Rotor. Influence of the following on rotor performance were noted:

1. Aerodynamic flutter. Since the rotor blades were constructed of solid wood, no aerodynamic flutter of the blade surfaces has been observed.
2. Gyroscopic forces due to sudden yawing. Gyroscopic forces were observed during heavy gusting winds, but were not significant enough to cause any problems. The installation of a commercially available automatic balancer on the rotor appears to dampen the gyroscopic rocking of the rotor.
3. Centrifugal forces. No unusually high centrifugal forces have been observed that would cause any damage to the system, including the blade attachment points.
4. Rotor-tower dynamic interaction. The natural frequency of the tower (1.5 Hz) is significantly less than the rotational speed range (1.67 to 3.33 Hz) of the rotor. Hence, no adverse rotor-tower dynamic interaction has been observed.

In addition, effect of blowing sand, dust, and salt air were considered. The pitching mechanism for the blades did experience some corrosion of the bearing surfaces due to the salt air. However, due to the body of water surrounding Treasure Island, no blowing sand and dust have been encountered at the WECS site.

Level of acoustical noise emission appears to be minimal (below 75 decibels). No effect upon Naval operations in nearby buildings was noted.

Drive System. Friction in the gearbox has not caused overheating or failure of its components. Temperature did not seem to affect drive system performance, and no significant problems were noted. However, no attempt was made to record temperature of the gear box oil.

Electrical Generator.

1. Output versus windspeed characteristics. The plots of power output versus windspeed, based upon the manufacturer's information and as measured in the field, are given in Figure 7. As pointed out in the Section on "System Description," the turbine's rotor diameter was increased from 16.417 (Rotor-1) to 17.417 feet (Rotor-2) in early December 1980 by installing new blades each 6 inches longer than the earlier set. The data points are plotted for the two rotors. The WECS performance data are presented in Tables C-1 and C-2 of Appendix C. It is evident from the plots of Figure 7 that increased rotor diameter resulted in higher power output and in reduced cut-in speed for the WECS.

2. Interaction of generator with control system and rotor dynamics. Control system has feathered the blades properly during high winds to effectively regulate power input to the generator.

3. Electrical and aerodynamic losses. Generator efficiency is measured by dividing generator output (DC) by available power in the wind. Using the data given in Table C-1, average generator efficiency for Rotor-1 ranged from about 18% to 35% as the windspeed values varied from 6.35 to 20.59 mph. The generator efficiency for Rotor-2, on the other hand, ranged from about 23.16% to 43.64% using the data collected in the 9-day period as the windspeed values ranged from 6.36 to 14.3 mph (Table C-2). Rotor-2 was found to be more efficient than Rotor-1.

4. Overload and overspeed characteristics. No overload condition has been observed. The control system has been effectively regulating the input power to the generator.

5. Short and no load effects on the generator operation. The shorting of generator terminals several times during demonstration did not cause any failure of the generator system. The generator has performed well under no load conditions over short intervals of time.

6. Effect of temperature, humidity, salt deposition, and water on the various connections and on performance. Salt deposition weakened the insulation around the electrical terminals located on WECS vertical shaft, thus grounding the generator to the tower. The power output of the generator was greatly reduced since only two instead of three phases were generating power.

7. Quality of power; i.e., the extent of harmonics generated. The current and voltage waveforms of the power from the WECS are shown in Figure 8. Due to the nature of the current waveform, some of the harmonics are fed into the power distributing system. However, the warehouse electrical system at the WECS site has not experienced any problems due to the presence of harmonics in the line.

Controls.

1. Sensitivity and stability of controls to windspeed and direction and rotor rotational speed. The controlling of the rotor rotational speeds under the load and beyond rated power point has been successful to date. The rotor blades have properly feathered during periods of windspeeds above the rated speed of the machine (28 mph). Additionally, the control mechanism responsible for automatically turning the rotor out of the wind, by rotating the tail 90 degrees, has functioned effectively during periods of extreme windspeeds above 45 mph and during no-load conditions.

2. Effect of temperature, humidity, and dust on operation. The operation of the control system has not been adversely affected by temperature, humidity, or dust to date.

3. Starting (cut-in), restarting, and shutdown including full or partial feathering characteristics. Excellent.

4. Simplicity and reliability of control system design. The control system has functioned properly so far with no recorded failures.

Tower.

1. Isolation of resonant frequency to minimize rotor-tower interaction. The natural frequency of the tower (1.5 Hz) is significantly less than the rotational speed range of the rotor (1.67 to 3.33 Hz).

2. Ease of installation. Erection of the tower was relatively easy, requiring only 2 men and use of a crane.

3. Tower shape and appearance. No complaints regarding the appearance of the generator-tower configuration at the site have been received.

4. Cost data. The free standing tower selected for this demonstration is about 60% more expensive than the guy wire type of tower used at some sites.

5. Tower stability. The stability of the tower during high winds has been good with no adverse shaking observed.

Synchronous Inverter.

1. Interfacing characteristics of synchronous inverter with permanent-magnet-type generator. No significant problems encountered thus far. Impedance matching is extremely important to optimize power conversions with varying windspeeds.

2. Efficiency and electrical losses. The inverter efficiency is computed by dividing the inverter output by the generator output. For Rotor-1, the inverter efficiency varied from about 63.8% to 83.6% (Table C-1) whereas with Rotor-2, the efficiency values varied from 70% to 79% (Table C-2). Generally, the inverter efficiency improved with Rotor-2.

3. Quality of power output. Typical grid voltage and current waveforms present at the output terminals of the synchronous inverter are shown in Figure 8. The inverter has not produced any significant distortion of the grid voltage waveform. The current waveform, however, does contain harmonics. The harmonic content of the current waveform recently analyzed for this type of inverter* concluded that, although higher order harmonics may exist and may be as high as 11% in the case of the third harmonic, the first harmonic contributes, on the average, 98% of the total power being transferred.

4. Interference (both electrical and electromagnetic) with the grid. None reported so far and no measurement was made to assess EMI effects.

5. Design capable of optimum conversion of wind power. Not enough performance data at higher wind speeds to evaluate this element of the test objectives.

6. Relative ease of interfacing with Station grid. No problems encountered so far.

Maintenance Data

Rotor.

1. Adequacy of bonds and fasteners and the blade's attachment connection to the rotor hub. The modified hub assembly Rotor-2 installed with the new blades contains better bonds and fasteners than the original design. Power to the rotors has presented no problems to date. Both rotors utilized laminated wood blades.

2. Blade fatigue cracks. No visible cracks. No X-ray type inspection was conducted.

*Windworks, Inc. op. cit.

3. Resistance to corrosion of various components. The environment at Treasure Island is moderately corrosive in nature. The rotor components appear to offer good resistance to the environment at Treasure Island.

4. Ease of repair or replacement of various components. Disassembly of the modified hub does not pose any problems. Slip fit connections replace the original press fits to enable easier dismantling of components in the field.

Drive System.

1. Lubrication and servicing requirements. The lubricating oil must be changed every 6 months.

2. Ease of replacement or repair. No repairs were required.

Controls.

1. Lubrication and servicing requirements. Inspect system components and lubricate every 6 months.

2. Ease of replacement or repair. No repairs were required.

3. Blade pitching mechanism adjustment requirements. Improvements in the blade pitching mechanism constitute the major modification made to the hub assembly. Thus far, only the initial adjustment made during installation has been required. The oil filled hub assembly in Rotor-2 does cause oil leaks when the rotor is turning.

4. Checking of overspeed and feathering system, cut-in/cut-out system, and rotor lockout for servicing. Must be checked every 3 months.

Electrical Generator.

1. Maintenance of the connections, such as slip rings and generator terminals. During the test period the insulation washers surrounding the generator terminals had to be replaced. The salt air environment weakened the original insulation, allowing a short circuit to the tower to develop, which resulted in the two critical system failures.

2. Lubrication and servicing requirements of the bearings. Frequent lubrication of the bearings is not necessary. However, some lubrication problems exist in the bearings of the rotor blade pitching mechanisms. These problems are caused by infrequent operation of these components because the blades feather only when prevailing windspeed is equal to or greater than the WECS rated speed.

3. Accessibility and ease of repair or replacement. No repairs required so far.

4. Long-term integrity of connections and windings. Good.

Tower.

1. Adjust generator holding clamp. No adjustments have been required.
2. Protection against corrosion of various components of the tower. Good.

Miscellaneous.

1. Maintenance of adequate lightning protection. None required at Treasure Island site.

Reliability, Maintainability, and Availability Data

Number of Critical Failures. Those times when the system produced very little or no electrical power due to component failure, to date, have only occurred twice, resulting in critical failures. Both failures were caused by a corroded insulation washer on the yaw bearing electrical terminals, thus allowing one of the three phases of WECS to become grounded to the tower.

Times Before Critical Failure. To date, times before each failure are approximately 120 days and 460 days. This gives a mean time between failure (MTBF) of 290 days for the overall system.

Times to Repair.

1. Logistic time was the sum of time intervals during which the WECS was not capable of providing electrical power because one or more needed parts had to be obtained from outside sources. Typically, replacement parts such as rotor bearings and inverter required 3 to 4 weeks for their delivery.
2. Awaiting outside help time was the sum of time intervals during which the WECS was not capable of providing electrical power because outside assistance was required. The total time required to make travel arrangements for travel to Treasure Island averages about 2 to 3 weeks. Based upon this, a good estimate of time for providing outside help at the site was about 2 to 3 weeks.
3. Administrative time was the sum of time intervals during which the WECS was not capable of providing electrical power and no corrective maintenance was being performed. Whenever a problem with the WECS at the site was discovered, the personnel at the Station notified NCEL within 5 days.
4. Corrective maintenance time was the sum of time intervals during which repair, part replacement, alignment, or adjustment was undertaken in order to correct a failure, and the WECS was not capable of providing

electrical power. Mean time to repair (MTR) was defined as the arithmetic average of all corrective maintenance times. The corrective maintenance performed at the site required an average of 2 to 3 days for completion. For example, the installation of the modified rotor assembly with the longer blades required only 2 days of field work.

Availability. Availability was defined as the probability that the WECS would be capable of providing electrical power at any random point in time. It was calculated as:

$$A = \frac{\text{Uptime}}{\text{Uptime} + \text{Downtime}}$$

The value of availability A computed from the field tests for the WECS at Treasure Island is about 0.65. A good WECS installation must have A close to 0.95. The test and evaluation nature of the WECS setup at Treasure Island is partly responsible for a low availability. However, future tests will be directed at establishing this parameter for the WECS.

Power Output Data

Generator Efficiency. The WECS performance was measured during three separate test periods. The first two tests evaluated the WECS with Rotor-1 before installation of the new rotor assembly with the longer blades of Rotor-2. Average generator efficiency for these periods varied from 18% to 35%. The final test period evaluated the WECS with Rotor-2, and the test results indicate that the generator efficiency, depending upon the windspeed, ranged between 23% to 43%.

Synchronous Inverter Efficiency. This performance parameter was also computed based upon the field measurements taken during the test periods and the results are described in the Operating Data section on the synchronous inverter.

Overall System Efficiency. The overall system efficiency is defined as the product of the generator efficiency and inverter efficiency. The WECS overall system efficiency with Rotor-1 varied from 11.7% to 28.07% (Table 4). The values of overall system with Rotor-2 ranged from 16.6% to 32.07% (Table 5). Hence, the overall system improved with Rotor-2, and the WECS efficiency increased with the increase in windspeed.

Instantaneous Power Output of the WECS. The WECS power output as a function of windspeed, based upon manufacturer's information, is plotted in Figure 7 as a solid line. The figure also shows the data points from the field tests of the WECS with points from the original design (Rotor-1) and the longer blade design (Rotor-2), respectively. The data collected during the tests are up to windspeeds of 18 mph. The WECS power levels with Rotor-1 are in agreement with manufacturer's curve. The power output from WECS increased by 10% with Rotor-2.

Long-term Output of the WECS. During the 295-day period ranging from 20 May 1980 to 10 March 1981, about 1,115 kW-hr of AC power were generated by the WECS. If extrapolated linearly this represents an annual rate of 1,380 kW-hr. Since the windy period at Treasure Island extends from March through July, this extrapolation is not realistic. A practical WECS installation of the Rotor-2 design at Treasure Island is capable of producing about 3,300 kW-hr annually.

Summary of Performance

WECS performance with the two rotors is summarized in the following table:

<u>Rotor Diameter (ft)</u>	<u>Period</u>	<u>Average Generator Efficiency (%)</u>	<u>Average Inverter Efficiency (%)</u>	<u>Average System Efficiency (%)</u>
16.417	7-15 Jun 1980	21	78	16
16.417	2-3 Dec 1980	30	78	23
17.417	27 Dec 1980 - 4 Jan 1981	34	76	26

CONCLUSIONS

1. All the data on WECS performance at Treasure Island are taken at windspeeds below 20 mph (Figure 7). Since the WECS installation in September 1979, its performance has been satisfactory. Only two critical failures, where the system produced no electrical power due to component failure, have occurred. The first failure occurred in late December 1979 and the second in early April 1981. Each failure was caused by the arcing at electrical terminals located on the yaw shaft of the generator which resulted in grounding of the generator to the tower.
2. The operating times before failure have been approximately 120 days and 460 days, which correspond to a system MTBF of 290 days.
3. The only other technical problem encountered during the demonstration has been difficulty in keeping the synchronous inverter properly programmed to match its impedance with that of the generator at all windspeeds. For optimum performance of the WECS it is extremely important to match its impedance to that of the AC line at all windspeeds.
4. Between 20 May 1980 and 10 March 1981, a 295-day interval, 1,115 kW-hrs of AC and 1,430 kW-hrs of DC power were supplied by the WECS and generator, respectively. These values correspond to annual outputs of 1,380 and 1,769 kW-hrs, respectively. The inverter efficiency during this period ranged between 75% and 81%.

RECOMMENDATIONS

1. A more efficient means of maintaining the synchronous inverter in a properly programmed status needs to be devised. The WECS performance has not been very good during periods in which the inverter was not programmed properly, and sometimes these periods of poor performance have extended for several weeks before it was realized that a problem existed.
2. All of the test data for WECS performance at Treasure Island were taken at windspeeds below 20 mph. To measure WECS performance at higher windspeeds, it must be moved to a site with an annual average windspeed of 14 mph or more.

Table 1. Specific Details on the 6-kW WECS Demonstration at Treasure Island

Item	Detail	Description	
Wind Turbine Generator			
Propeller	Type	Rotor-2	Rotor-1
	Number of blades	3	3
	Diameter	17 ft 5 in.	16 ft 5 in.
	Circular area swept by blades	238.3 ft ²	211.7 ft ²
	Projection of blades on swept circular area		
	Aerofoil area density	5.2%	5.2%
	Rotational speed	100-200 rpm	100-200 rpm
	Rated windspeed	28 mph	28 mph
	Cut-in windspeed	8 mph	9 mph
	Furling windspeed	45 mph	45 mph
Location with respect to tower	Upwind	Upwind	
Rated power coefficient	0.256	0.256	
Gear Box	Type	Gear	
	Gear ratio	4 to 12	
Generator	Type	Three-phase permanent-magnet rotor	
	Number of poles	16	
	Rotational speed	412-824 rpm	
	Output frequency	DC	
	Rated voltage	140 volts	
	Rated power output	6.75 kW	6 kW
Tower	Type	Open truss, free-standing	
	Height	60 ft	
Power Conditioning Equipment			
	Type	Single-phase, line-commutated inverter	
	Rated voltage	120 volts AC	
	Rated power output	7.5 kW	
Site Wind Characteristics			
	Annual average wind speed, mph	8-10 mph	
	Average available power in the wind	4-5 watts/ft ²	

Table 2. Economic Analysis for the WECS With a Rating of 6 kW at 28 mph at Various Naval Sites

Items	Sites					
	Treasure Island	San Nicolas Island	Adak	Grand Turk	Kaneohe Bay	Opana
Annual average windspeed, mph	9.0	11.4	13.9	15.9	12.0	16.8
WECS annual output, kW-hr	3,000	7,500	10,800	13,800	7,800	15,700
Capital cost of WECS, \$K	14.0	14.5	15.0	15.0	15.0	15.0
WECS operations & maintenance annually, \$K	0.50	0.60	0.60	0.60	0.60	0.60
<u>Diesel-Generated Electrical Costs</u>						
Fuel, mills/kW-hr	-	90	90	90	-	-
Annual operations & maintenance, \$K	-	0.70	0.70	0.70	-	-
Purchased electricity cost per kW-hr, mills	80	-	-	-	90	90
<u>Costs Displaced by WECS Annually, \$K</u>						
Fuel or purchased electricity, \$K	0.24	0.68	0.97	1.24	0.70	1.41
Operations and maintenance	-	0.1	0.1	0.1	-	-
<u>Economic Comparison</u>						
Differential life cycle cost, \$/MBtu	-0.02	0	-0.0022	-0.0034	-0.0037	-0.0021
Discounted payback period, yrs (economic life of WECS = 25 yrs)	no pay back	25 years	11.7	8.0	no pay back	9.8

Table 3. Specifications for the Two Wattmeters Used in the WECS Installation

Item	DC Wattmeter	AC Wattmeter
Model	WH-7 Series 34 Ohio Semi-tronics	WH-3 Series 65 Ohio Semi-tronics
Input		
Current, normal	200 A maximum, 2 x rating	100 A maximum, 2 x rating
Voltage, normal	120 volts maximum, 1.25 x rating	240 volts maximum, 1.25 x rating
Phase, wire	DC phase, 2 wire	3-phase, 4 wire
Outputs (signal)		
Power	8 volts DC = 25 kW	7.5 volts DC = 80 kW
WH pulses	819.2/W-hr	204.8/W-hr
Electromechanical counter	10 W-hr/count	10 W-hr/count

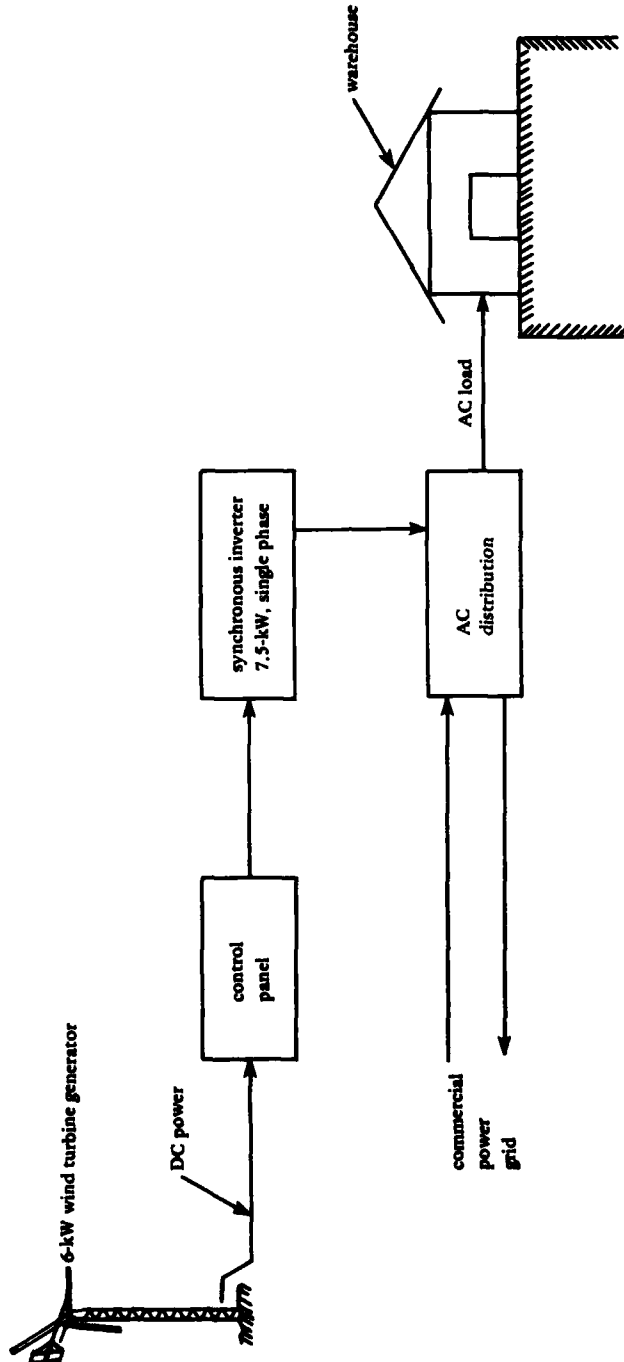

Figure 1. A schematic of the 6-kW wind plant with a single-phase synchronous inverter facility integrated with a warehouse power supply at Naval Station, Treasure Island.

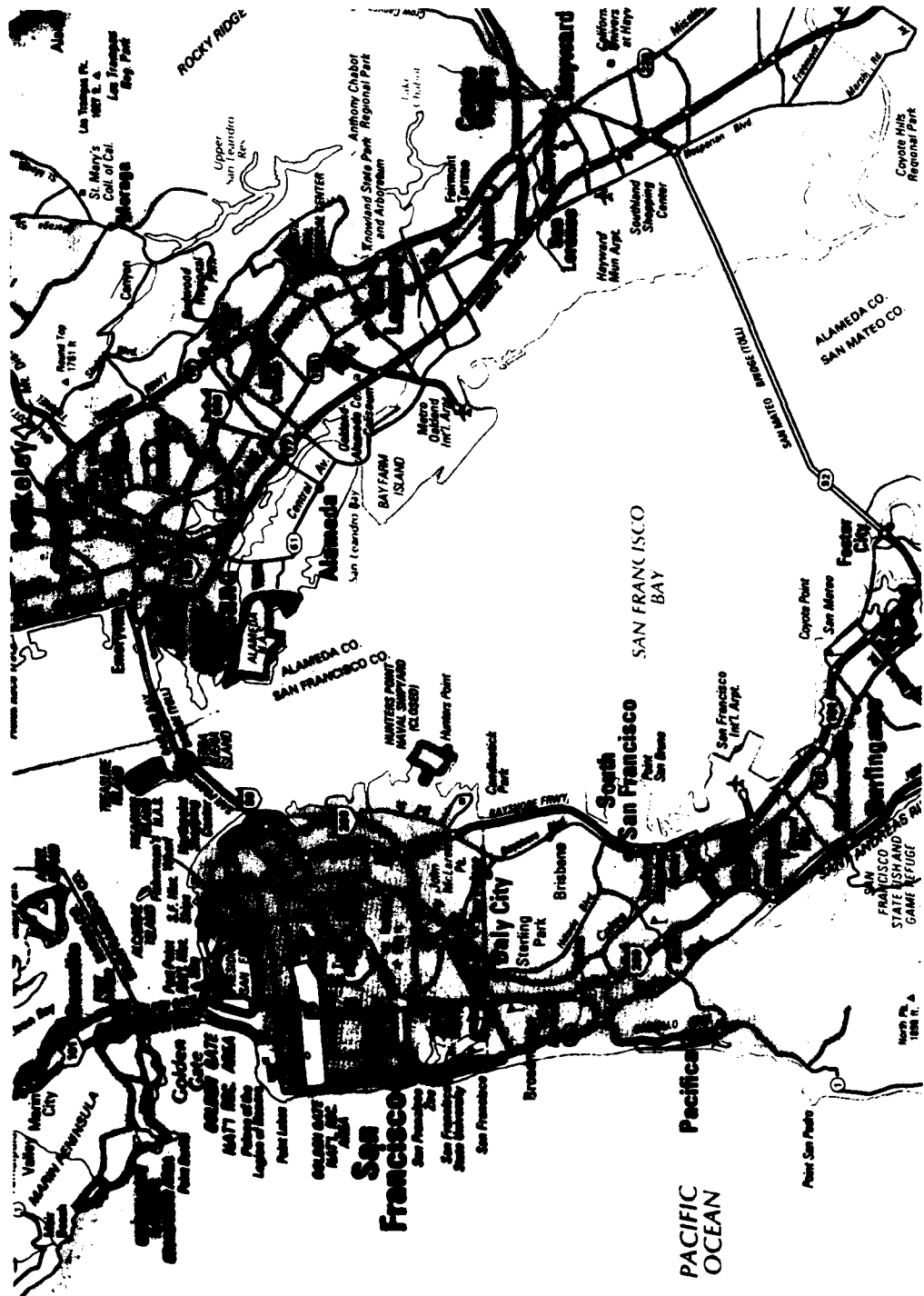

Figure 2. Relative location of NS, Treasure Island in the San Francisco Bay area.

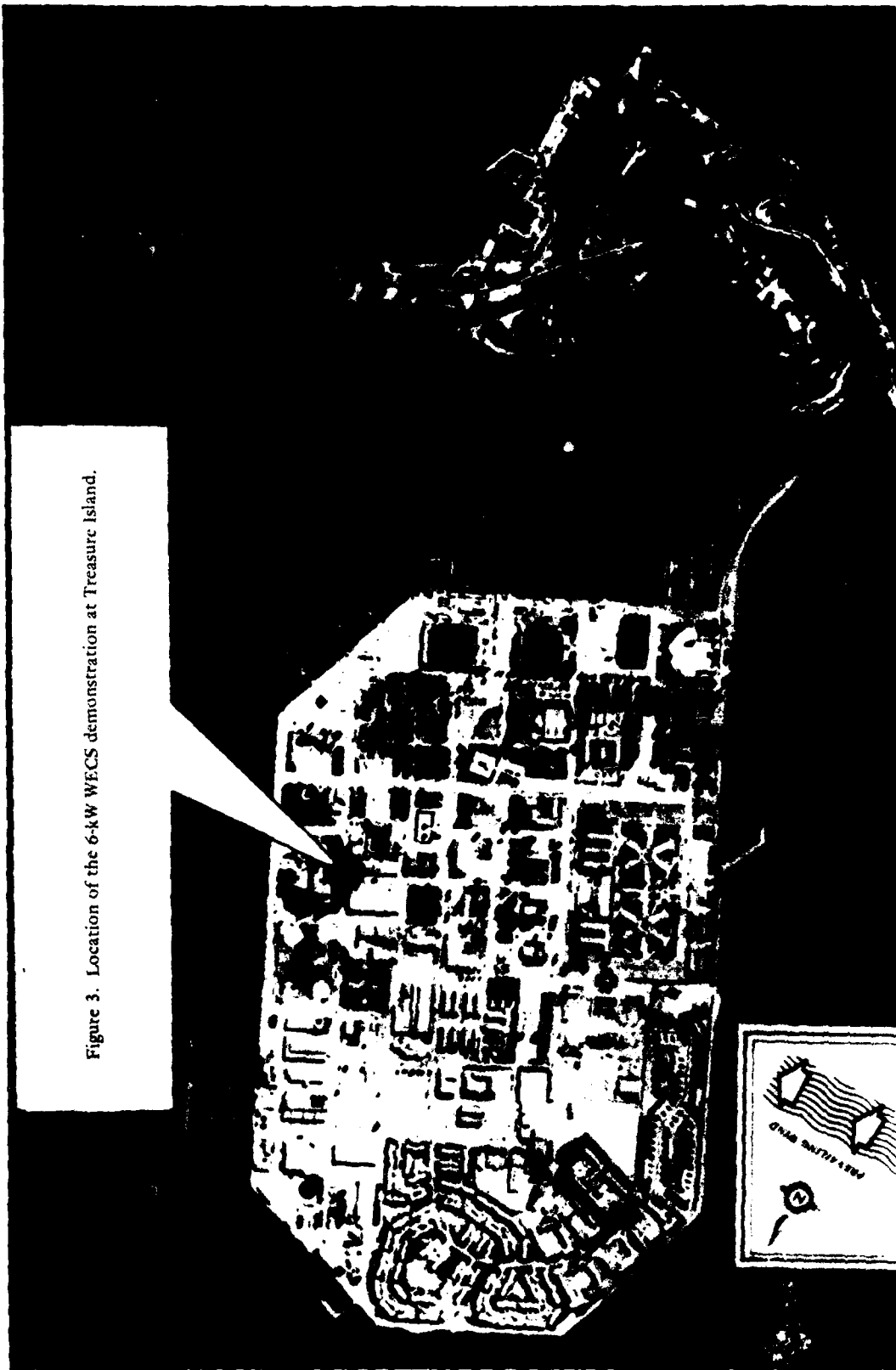

Figure 3. Location of the 6-kW WECS demonstration at Treasure Island.

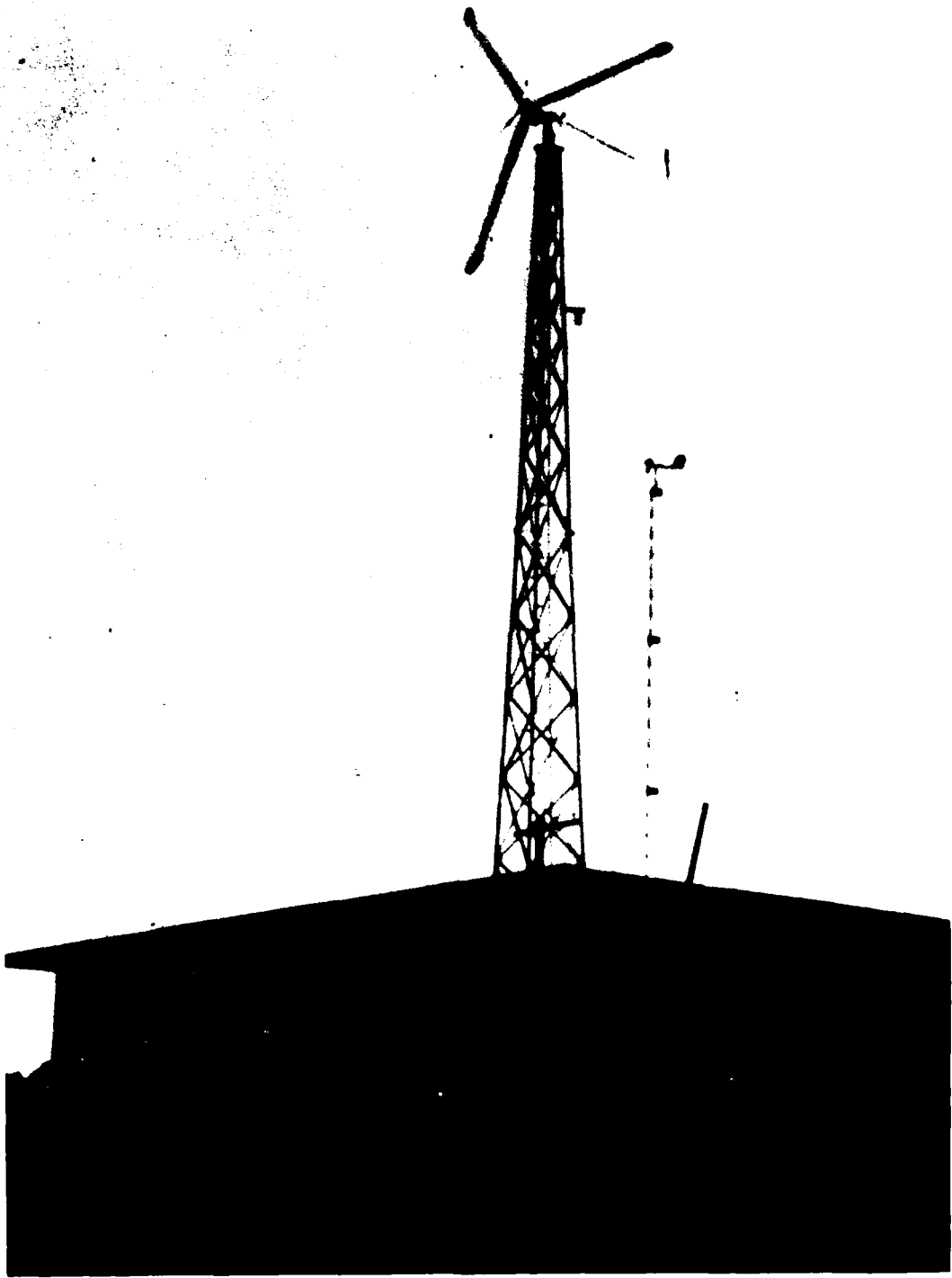

Figure 4. WECS installation at Treasure Island.

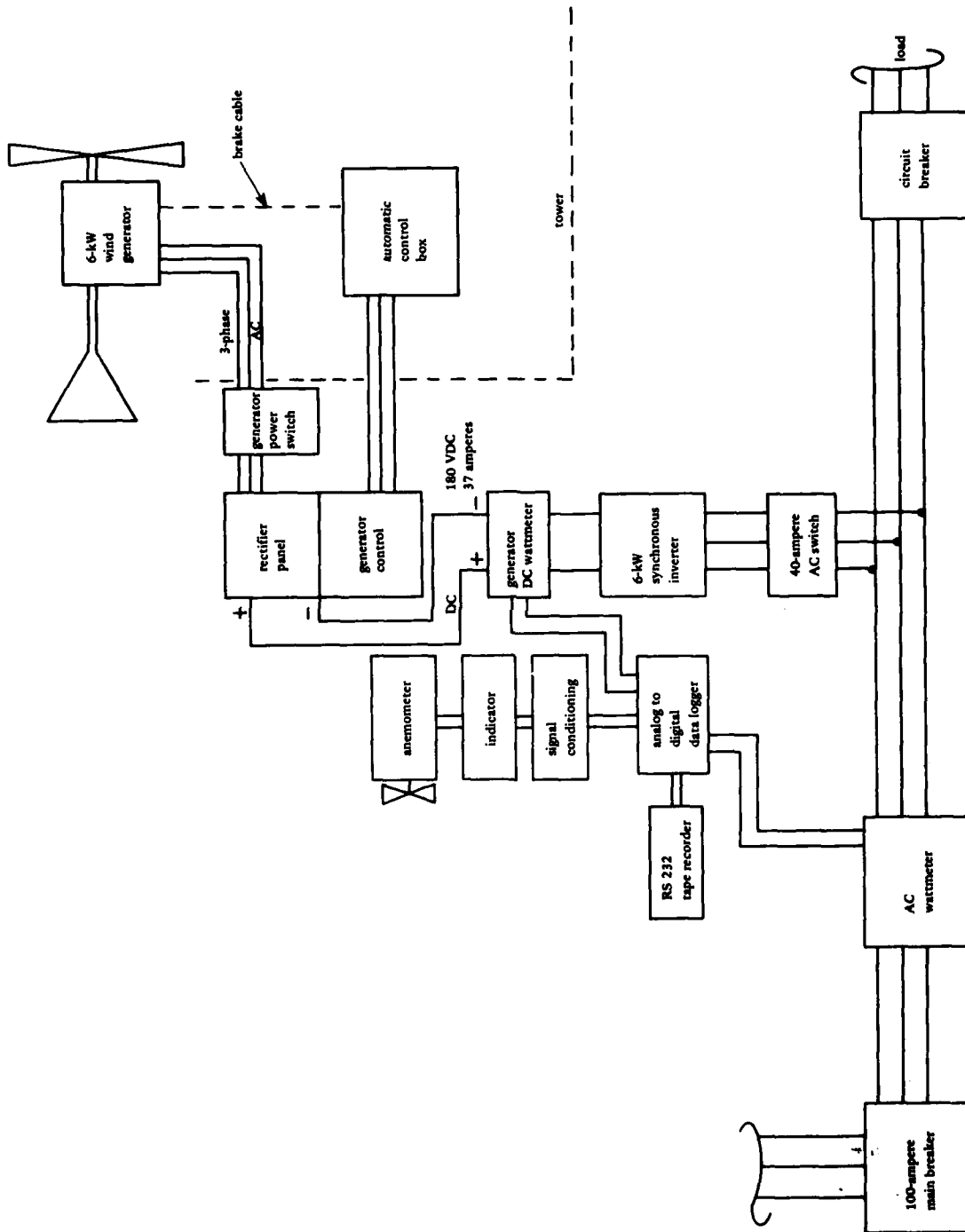

Figure 5. Wiring diagram for the wind generator and synchronous inverter at Treasure Island.



Figure 6. Instrument panel at Treasure Island for data collection.

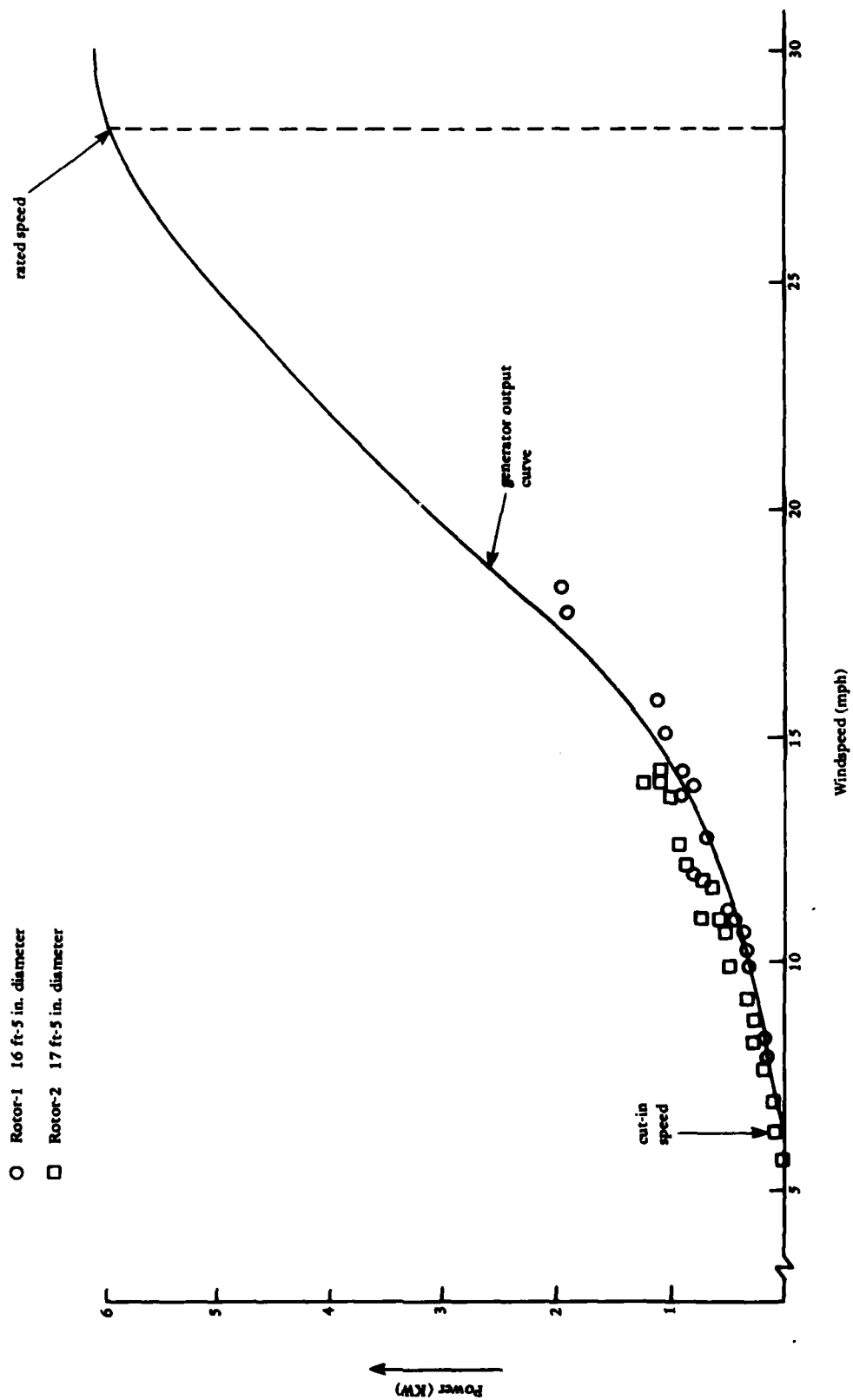

Figure 7. Performance curve for the 6-kW WECS with a synchronous inverter at NS, Treasure Island.

Inverter Performance

Windspeed = 11.99 mph
AC power = 0.72 kW
DC power = 0.80 kW
Inverter efficiency = $0.72/0.80 = 90\%$

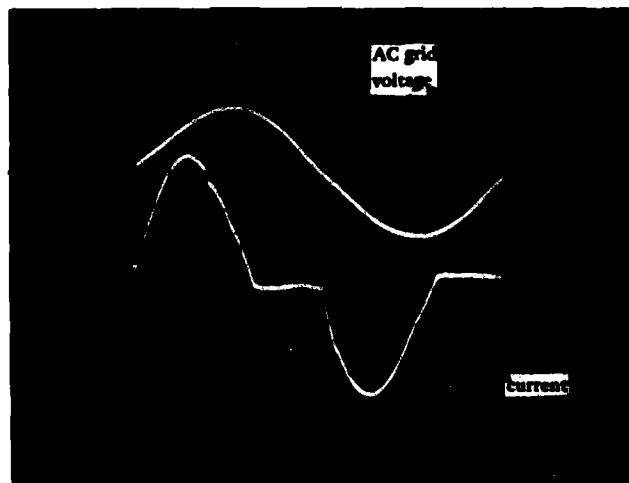

Figure 8. Synchronous inverter output waveforms at NS, Treasure Island.

Appendix A

LINE-COMMUTATED OR SYNCHRONOUS INVERSION OF
DC POWER

For simplicity, consider a single-phase AC line connected to a source of DC power through a system of thyristors arranged in a bridge arrangement as shown in Figure A-1. The source of DC power in Figure A-1 is the output of a wind turbine-driven DC generator or an alternator with its output rectified.

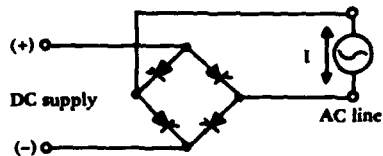

Figure A-1. Schematic of a synchronous inversion circuit.

Next, Figure A-2 shows alternate paths for current flow from the DC source to the AC line, depending upon the polarity of the AC line voltage.



Figure A-2. Two paths of power flow from wind-generated DC source to AC lines.

Further, the relative voltage and the wave form of the AC line and the DC source for the first path of power flow (Figure A-2(a)) is shown in Figure A-3 schematically. While Figure A-3 shows an arbitrary value of DC voltage, the actual magnitude can be any value from zero to the peak of the AC line. During the positive half cycle there are two distinct intervals, 1 and 2,

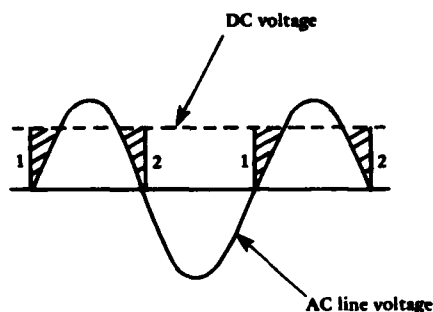

Figure A-3. A graphical description of DC source and AC line voltages.

where the DC source voltage is instantaneously more positive than the AC line voltage. Hence, current flows from the DC source to the line, and thus there is a flow of power to the line. During the negative half cycle of the AC line voltage, current does not oppose the line voltage, and power flow is in the opposite direction (i.e., from the AC line to the DC source).

The time intervals 1 and 2 have one significant difference as explained here. During interval 1, the difference between the AC and DC voltages is initially high and decreases to zero. This condition is useful when thyristors are employed as the power switches because it automatically reduces the current in the thyristors to zero, thus making it commutate naturally. In interval 2 the reverse occurs; that is, the voltage differential is zero initially and increases with time until it attains a large value at the end of the interval. For a thyristor to function properly during this interval, an independent or external means of commutating is generally required to switch it to the off-state. For thyristors, the commutating circuitry can be complex, and for this reason the conversion period is generally limited to interval 1 and the inverter is called a line-commutated inverter.

The circuitry of Figure A-2(a) and the DC power wave form depicted in Figure A-3 provide line current of a single polarity, and the power thus transferred to the AC line is DC. Hence, a circuitry of Figure A-2(b) is also needed for proper inversion of DC power from the wind generator. Figure A-4 shows the DC voltage and AC line wave form for a synchronous inverter technique based upon schematics of Figure A-2. The current flowing from the DC power source is truly AC and has the wave form given in Figure A-5. The discussion given here primarily applies to single-phase inverters, but the same principles can be extended to multiphase circuits.

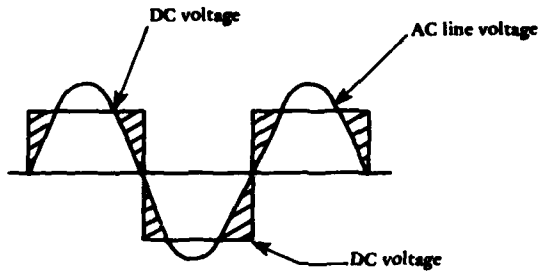

Figure A-4. A graphical description of synchronous inverter integration with the AC line.

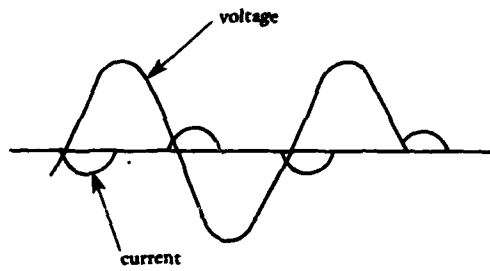

Figure A-5. Current and voltage profiles for the synchronous inversion method.

Appendix B
FIELD DATA LOG AND SYSTEM OPERATION RECORDS

Date	AC Wattmeter Reading	Average W-Hr/Day	DC Wattmeter Reading	Average W-Hr/Day	Average Inverter Efficiency	Comments
12-10-79	001436		027619			
12-17-79	001564	18	031310	527	0.03	
12-21-79	001616	13	032286	244	0.05	Severe winds are being experienced at the site.
12-22 & 12-23-79						
12-26-79	002342	145	044352	2,413	0.06	
1-7-80	002446	9	047486	261	0.03	Severe winds prevailing. The Weather Bureau reports wind gusts from 40 to 70 mph at Angel Island approximately 3 miles northwest of Treasure Island in the San Francisco Bay.
1-12 & 1-13-80						
1-14-80	002535	13	051645	594	0.02	The generator is found feathered out of the wind as a result of the machine's furling windspeed being exceeded. The unit is cranked back into the wind.
1-18-80						NCEL personnel made minor repairs and adjustments to the system. They also left instructions to use only one side of the cassette tape.

continued

Date	AC Wattmeter Reading	Average W-Hr/Day	DC Wattmeter Reading	Average W-Hr/Day	Average Inverter Efficiency	Comments
1-21-80	002588	8	054180	362	0.02	The cassette tape was changed and mailed to NCEL. Only one side was used - the tape lasted approximately two weeks.
1-28-80	002690	15	056704	361	0.04	
1-31-80						
2-4-80	002768	20	058520	454	0.04	The cassette tape was removed. Treasure Island experienced a rainstorm with winds from 10 to 20 mph.
2-11-80	003440	96	069060	1,506	0.06	
2-15-80						
2-20-80	003769	66	078508	1,050	0.06	The cassette tape was removed. One side only was used. The tape was shipped to NCEL.
2-27-80	003885	17	081636	447	0.04	
3-3-80	003939	11	083102	283	0.04	
3-8-80	004090	30	086876	755	0.04	Strong winds are being experienced at the site.
3-17-80	004231	16	090618	416	0.04	
3-24-80	004443	30	096547	847	0.04	
3-29 & 3-30-80						

continued

Date	AC Wattmeter Reading	Average W-Hr/Day	DC Wattmeter Reading	Average W-Hr/Day	Average Inverter Efficiency	Comments
3-31-80	004610	24	101301	679	0.04	The tape is changed. Both the AC and DC meters are set to "0". NCEL personnel made adjustments and checked generator performance. The machine performs much more efficiently following the adjustments. High winds up to 40 mph are being experienced at the site. With the new setting, the machine cuts in at approximately 7 mph. Rotor rotation is sporadic between 7 and 10 mph. Above 10 mph, rotation is continuous.
4-7-80	004812	29	106995	813	0.04	
4-14-80	004912	14	109629	376	0.04	
4-21-80	005104	27	115127	785	0.03	
4-28-80	005297	28	120397	753	0.04	
5-5-80	005521	32	126738	906	0.04	
5-12-80	005784	38	135034	1,185	0.03	
5-19-80	005952	24	139670	662	0.04	
5-20-80	000000		000000			
5-20 - 5-23-80						
5-27-80	045734	6,533	056346	8,049	0.81	
6-2-80	078046	5,385	096658	6,719	0.80	
6-6-80	104471	6,606	129438	8,195	0.81	

Continued

Date	AC Wattmeter Reading	Average W-Hr/Day	DC Wattmeter Reading	Average W-Hr/Day	Average Inverter Efficiency	Comments
6-9-80	121907	5,812	151395	7,319	0.79	
6-16-80	169467	6,794	210794	8,486	0.80	
6-23-80	229359	8,556	286455	10,808	0.79	
6-30-80	263095	4,819	329560	6,158	0.78	
7-9-80	328410	7,257	413012	9,272	0.78	
7-14-80	365358	7,390	460514	9,500	0.78	
7-28-80	448355	5,928	567762	7,660	0.77	
8-4-80	486921	5,509	617673	7,130	0.77	
8-12-80	527973	5,132	670423	6,594	0.78	
8-18-80	558532	5,093	710195	6,629	0.77	
8-25-80	586478	3,992	746276	5,154	0.77	
9-2-80	623867	4,674	794931	6,082	0.77	
9-8-80	652585	4,803	832368	6,240	0.77	
9-15-80	692500	5,688	883452	7,298	0.78	
9-22-80	716114	3,373	914385	4,419	0.76	
9-29-80	743879	3,966	950628	5,178	0.77	
10-14-80	787305	2,895	007492	3,791	0.76	
10-21-80	798004	1,528	021575	2,012	0.76	
11-4-80	817550	1,396	047392	1,844	0.76	
11-6-80						The System was inspected and lubricated by NCEL personnel. No major maintenance problems were noted.

Continued

Date	AC Wattmeter Reading	Average W-Hr/Day	DC Wattmeter Reading	Average W-Hr/Day	Average Inverter Efficiency	Comments
11-12-80	823128	697	054780	924	0.75	
11-17-80	832015	1,777	066576	2,359	0.75	
11-25-80	843163	1,394	081050	1,809	0.77	
12-1-80	847861	783	087308	1,043	0.75	
12-8-80	890933	6,153	142024	7,817	0.79	
12-10-80	891792	430	143113	545	0.79	NCEL personnel changed the hub and blades on the turbine. The new blades are 6 inches longer than the previous ones. The unit was lubricated.
12-15-80	904857	2,613	160113	3,400	0.77	
12-22-80	911946	1,013	169333	1,317	0.77	
12-29-80	933544	3,085	197270	3,991	0.77	
1-5-81	962315	4,110	234430	5,309	0.77	
1-12-81	993273	4,423	274562	5,733	0.77	
1-20-81	001992	1,090	285738	1,397	0.78	
1-26-81	020211	3,037	309109	3,895	0.78	
2-2-81	058176	5,424	357163	6,865	0.79	
2-9-81	059909	248	359440	325	0.76	NCEL personnel installed a new tape recorder and checked the equipment. An oil retainer shield was left for Naval Station personnel to install on the

Continued

Date	AC Wattmeter Reading	Average W-Hr/Day	DC Wattmeter Reading	Average W-Hr/Day	Average Inverter Efficiency	Comments	
2-18-81	064532	514	365520	676	0.76	generator. Shortly after the repairs of the recording equipment were made, the paper tape jammed in the printer and neither the paper printout nor the tape recorder operated satisfactorily.	
2-23-81	084890	4,072	391373	5,171	0.79		
3-2-81	106382	3,070	418934	3,937	0.78		
3-10-81	114680	1,037	429811	1,360	0.76		
4-13-81	125721	325	473779	1,293	0.25		
4-22-81	128201	276	519602	5,091	0.05		
4-28-81	130493	382	552597	5,499	0.07		
5-4-81	130738	41	579076	4,413	0.009		
5-11-81	130913	25	604780	3,672	0.007		
5-18-81	131656	106	640706	5,132	0.02		The machine cut in at a wind velocity of 9 mph and stayed on line at wind-speeds of 9 mph and greater.
5-19-91	000000		000000				

Continued

Date	AC Wattmeter Reading	Average W-Hr/Day	DC Wattmeter Reading	Average W-Hr/Day	Average Inverter Efficiency	Comments
5-20-81	002159	2,159	005504	5,504	0.39	The generator cut in at a windspeed of 9 mph. At this windspeed, the system generated approximately 0.4 kW of AC power. A new cassette tape was installed.
5-22-81	011263	4,552	022262	8,379	0.54	
5-26-81	023243	2,995	048214	6,488	0.46	
6-1-81	058246	5,834	111503	10,548	0.55	
6-7-81	087131	4,814	166776	9,212	0.52	
6-15-81	116758	3,703	225025	7,281	0.51	
6-22-81	127483	1,532	256465	4,491	0.34	
6-30-81	172322	5,605	339688	10,403	0.54	

Appendix C

WECS PERFORMANCE DATA FOR ROTOR-1 AND ROTOR-2

Table C-1. WECS Performance Data for Rotor-1.
(Running average data with 1 hour averaging period)

Date	Time	Wind Speed (mph)	Ambient Temperature (°F)	Available Power In Wind (kW)	DC Generator Output (kW)	AC Inverter Output (kW)	Efficiency		
							Generator (%)	Inverter (%)	System (%)
7 Jun 1980	1700	14.13	69.3	3.075	0.606	0.461	19.7	76.1	15.0
	1800	15.68	67.6	4.202	0.789	0.605	18.8	76.7	14.4
	1900	12.71	64.03	2.238	0.591	0.448	26.4	75.8	20.0
	2000	11.09	56.9	1.487	0.374	0.281	25.2	75.1	18.9
8 Jun 1980	1200	12.87	59.7	2.324	0.462	0.343	19.9	74.2	14.8
	1300	14.75	60.7	3.498	0.555	0.415	15.9	74.8	11.9
	1400	15.70	61.6	4.219	0.794	0.605	18.8	76.2	14.3
	1500	14.29	64.3	3.181	0.668	0.505	21.0	75.6	15.9
	1600	16.35	68.0	4.765	1.017	0.794	21.3	78.1	16.6
	1700	17.68	67.8	6.024	1.122	0.879	18.6	78.3	14.6
10-Jun 1980	1400	20.32	57.5	9.146	2.013	1.683	22.0	83.6	18.4
	1500	20.59	59.7	9.516	1.886	1.558	19.8	82.6	16.4
	1700	18.09	65.08	6.453	1.661	1.335	25.7	80.37	20.7
15 Jun 1980	1000	6.35	57.7	0.2791	0.0510	0.0325	18.3	63.8	11.7
	1100	7.90	58.95	0.5375	0.117	0.0825	21.8	70.5	15.4
	1200	11.63	59.4	1.715	0.396	0.290	23.1	63.9	14.8
	1300	9.78	62.3	1.020	0.239	0.176	23.4	73.6	17.2
	1400	10.92	62.9	1.419	0.330	0.240	23.3	72.70	16.9
	1500	14.65	64.7	3.428	0.713	0.538	20.8	75.5	15.7
	1600	13.28	71.3	2.553	0.513	0.379	20.1	73.9	14.9
	1700	13.69	71.61	2.797	0.618	0.465	22.1	75.2	16.6
	1800	11.70	70.9	1.746	0.360	0.265	20.7	73.6	15.2
	1900	10.55	66.3	1.280	0.306	0.225	23.9	73.5	17.6

Continued

Table C-1. Continued

Date	Time	Wind Speed (mph)	Ambient Temperature (°F)	Available Power In Wind (kW)	DC Generator Output (kW)	AC Inverter Output (kW)	Efficiency		
							Generator (%)	Inverter (%)	System (%)
2 Dec 1980	2000	8.22	58.9	0.6055	0.173	0.126	28.6	72.8	20.8
	2100	8.61	52.8	0.6958	0.156	0.115	22.4	73.7	16.5
	2200	9.33	53.3	0.8853	0.225	0.164	25.4	72.9	18.5
	0200	6.75	51.36	0.3368	0.0540	0.038	16.03	70.37	11.28
	0300	8.35	51.70	0.6372	0.171	0.115	26.84	67.25	18.05
	0400	7.46	51.77	0.4543	0.132	0.0863	29.05	65.38	19.00
	0500	8.53	51.72	0.6792	0.194	0.130	28.56	67.01	19.14
	0700	8.08	52.58	0.5764	0.167	0.113	28.97	67.37	19.52
	0900	9.58	52.07	0.9616	0.300	0.221	31.20	73.75	23.00
	1000	10.67	52.04	1.329	0.431	0.325	32.43	75.49	24.48
	1100	11.12	53.17	1.501	0.470	0.356	31.32	75.83	23.75
	1200	12.72	54.41	2.241	0.674	0.523	30.08	77.65	23.35
	1300	12.33	55.75	2.035	0.678	0.528	33.32	77.88	25.95
	1400	13.52	57.82	2.673	0.942	0.749	35.24	79.51	28.02
	1600	14.00	58.51	2.964	1.031	0.826	34.79	80.16	27.87
1700	15.85	57.45	4.310	1.173	0.933	27.22	79.50	21.65	
2000	15.10	54.91	3.745	1.080	0.841	28.84	77.89	22.46	
2100	14.20	55.13	3.113	0.911	0.700	29.26	76.84	22.49	
2200	10.41	54.75	1.227	0.369	0.266	30.07	72.15	21.68	
2300	10.76	54.99	1.355	0.461	0.343	34.03	74.30	25.28	
2400	13.97	55.98	2.959	0.842	0.641	28.46	76.16	21.67	
3 Dec 1980	1600	17.80	51.26	6.178	1.947	1.59	31.52	81.66	25.74
	1700	18.38	50.21	6.816	2.007	1.633	29.45	81.37	23.95

Table C-2. Wecs Performance Data for Rotor-2.
(Running average data with 1-hour averaging period)

Date	Time	Wind Speed (mph)	Ambient Temperature (°F)	Available Power In Wind (kW)	DC Generator Output (kW)	AC Inverter Output (kW)	Efficiency			
							Generator (%)	Inverter (%)	System (%)	
27 Dec 1980	0938	12.18	47.47	2.245	0.812	0.620	36.16	76.35	27.61	
	1038	11.92	48.62	2.100	0.729	0.561	34.72	76.95	26.71	
	1138	11.76	49.66	2.012	0.654	0.501	32.51	76.64	24.91	
	1238	13.78	50.08	3.235	0.999	0.775	30.88	77.58	23.96	
	1438	14.30	49.40	3.620	1.043	0.8038	28.81	77.06	22.20	
	1738	10.79	48.02	1.559	0.537	0.403	34.44	75.05	25.85	
	1938	9.25	46.99	0.9844	0.338	0.248	34.34	73.37	25.19	
	30 Dec 1980	1538	12.72	50.78	2.541	0.9525	0.7525	37.49	79.00	29.61
		1638	13.92	49.12	3.341	1.2525	0.975	37.49	77.84	29.18
2 Jan 1981	1438	9.86	50.03	1.185	0.497	0.380	41.93	76.46	32.07	
	1638	12.01	45.83	2.159	0.714	0.543	33.07	75.98	25.15	
	1838	10.98	43.74	1.6571	0.569	0.428	34.34	75.13	25.83	
	2038	19.21	42.97	1.3344	0.437	0.325	32.75	74.37	24.36	
	2238	8.95	43.06	0.8987	0.302	0.220	33.60	72.85	24.48	
	2338	9.99	42.65	1.2508	0.506	0.375	40.45	74.11	29.98	
3 Jan 1981	0538	8.87	40.09	0.8800	0.384	0.281	43.64	73.24	31.93	
	0738	7.71	39.93	0.5781	0.191	0.136	33.04	71.20	23.53	
	0938	7.97	41.88	0.6361	0.197	0.144	30.97	72.97	22.63	
	1138	10.84	44.68	1.5916	0.561	0.421	35.25	75.10	26.45	
	1238	11.43	45.38	1.8633	0.630	0.473	33.81	75.00	25.39	
	1438	11.48	46.25	1.8846	0.584	0.439	31.00	75.13	23.29	
	1638	11.81	44.77	2.058	0.695	0.529	33.77	76.17	25.73	
2038	8.34	41.98	0.7287	0.215	0.160	29.50	74.42	21.96		

Continued

Table C-2. Continued

Date	Time	Wind Speed (mph)	Ambient Temperature (°F)	Available Power In Wind (kW)	DC Generator Output (kW)	AC Inverter Output (kW)	Efficiency		
							Generator (%)	Inverter (%)	System (%)
4 Jan 1981	2338	6.36	40.90	0.3239	0.075	0.054	23.16	71.67	16.60
	0038	7.14	40.80	0.4583	0.116	0.0813	25.31	70.04	17.73
	1838	6.40	43.95	0.3280	0.120	0.0875	36.58	72.92	26.68

DISTRIBUTION LIST

AF SM-ALC/XRE (J Pestillo) McClellan AFB, CA
AF AERO DEF COM HQS/DEE (T. Hein), Colorado Springs CO
AF ENERGY LIAISON OFF-SERI OFESC/OL-N (Capt B Tolbert) Golden CO
AF HQ LEEUU, Washington, DC
AFB (AFIT/LDE), Wright Patterson OH; (RDVA) AFESC/R&D Tyndall, FL; 314 CSG DEEE, Little Rock AFB, AR; 82ABG/DEMC, Williams AZ; ABG/DEE (F. Nethers), Goodfellow AFB TX; AF Tech Office (Mgt & Ops), Tyndall, FL; AFETO/DOSE, Tyndall AFB, FL; Air Base Group (MAC), Attus AFB, OK; CESCH, Wright-Patterson; DET Wright-Patterson OH; HQ AFSC/DEEE Andrews AFB MD; HQSAC DEPM, Offutt, NE; MAC/DET, Scott, IL; SAMSO/MNND, Norton AFB CA; Samsso/Dec (Sauer) Vandenburg, CA; Scol of Engrng (AFIT/DET); Stinfo Library, Offutt NE; Wright-Patterson, Energy Conversion, Dayton, OH
AFESC DEB, Tyndall, FL; HQ RDVS Tyndall FL
AFWL CE Div., Kirtland AFB NM
ARMY AFZI-FE-E, Fort Geo G. Meade, MD; ARRADCOM, Dover, NJ; BMDSC-RE (H. McClellan) Huntsville AL; Contracts - Facs Engr Directorate, Fort Ord, CA; DAEN-CWE-M, Washington DC; DAEN-MPE-D Washington DC; DAEN-MPR, Chief of Engrs Sol Therm/Sol Htg & Cool Washington; DAEN-MPU, Washington DC; ERADCOM Tech Supp Dir. (DELS-D) Ft. Monmouth, NJ; HQDA (DAEN-FEE-A); Install Suppact Europe, AEUES-RP APO New York; Natick R&D Command (Kwoh Hu) Natick MA; Tech. Ref. Div., Fort Huachuca, AZ
ARMY - CERL Library, Champaign IL
ARMY CORPS OF ENGINEERS MRD-Eng. Div., Omaha NE; Seattle Dist. Library, Seattle WA
ARMY CRREL G. Petteplace Hanover, NH
ARMY ENGR DIST. Library, Portland OR
ARMY ENVIRON. HYGIENE AGCY HSE-EW Water Qual Eng Div Aberdeen Prov Grnd MD; Librarian, Aberdeen Proving Ground MD
ARMY MATERIALS & MECHANICS RESEARCH CENTER Dr. Lenoe, Watertown MA
ARMY MISSILE R&D CMD SCI Info Cen (DOC) Redstone Arsenal, AL
ARMY MTMC Trans Engr Agency MTT-CE, Newport News, VA
ARMY-MERADCOM CFLO Engr Fort Belvoir VA; DRDME-WC Ft Belvoir VA
ASO PWD (ENS M W Davis), Philadelphia, PA; PWD - Dir. Engr. Br., Phila, PA; PWO, Phila, PA; PWO, Philadelphia PA
ASST SECRETARY OF THE NAVY R&D Washington, DC
DOE Knolls Atomic Power Lab (Library) Schenectady, NY
BUREAU OF RECLAMATION Code 1512 (C. Selander) Denver CO
CHNAVPERS Code PERS-M113, Washington DC
CINCLANT CIV ENGR SUPP PLANS OFFR NORFOLK, VA
CINCPACFLT SCE, Pearl Harbor HI
CNAVRES Code 13 (Dir. Facilities) New Orleans, LA
CNM Code MAT-04, Washington, DC; Code MAT-08E, Washington, DC; NMAT - 044, Washington DC; NMAT - 08T242 Washington, DC; NMAT 08T4 (P.B. Newton), Washington DC
CNO Code NOP-964, Washington DC; Code OP 987 Washington DC; Code OP-413 Wash, DC; Code OPNAV 09B24 (H); OP-098, Washington, DC; OP987J, Washington, DC
COMFAIRMED SCE, Code N55, Naples IT
COMFLEACT, OKINAWA PWD - Engr Div, Sasebo, Japan; PWO, Kadena, Okinawa; PWO, Sasebo, Japan
COMFLTAIR SCE (Code 321) Atsugi JA
COMNAVAIRPAC Code 53, San Diego, CA
COMNAVLOGPAC SCE, Pearl Harbor HI
COMNAVMIANAS Code N4, Guam
COMNAVSUPPPFORANTARCTICA PWO
COMOCEANSYSLANT PW-FAC MGMNT Off Norfolk, VA
COMOCEANSYSPAC SCE, Pearl Harbor HI
COMSUBDEVGRUONE Operations Offr, San Diego, CA
DEFENSE DEPOT OGDEN E. Fronk, Ogden UT; PWO, Ogden, UT
DEFENSE ELEC SUP CEN PWO, Dayton OH
DEFUELSUPPCEN DFSC-OWE, Alexandria VA
DIR. DEFENSE RSCH & ENGR Pentagon (Rm 3C-128), Washington DC
DNA Tech. Services Library, Mercury NV
DNL Washington DC
DOE F.F. Parry, Washington DC; INEL Tech. Lib. (Reports Section), Idaho Falls, ID; OPS OFF (Capt WJ Barrattino) Albuquerque NM
DTIC Defense Technical Info Ctr/Alexandria, VA
DTNSRDC Anna Lab (Code 4120) Annapolis MD; Anna Lab, Code 2705 (S. McPherson) Annapolis, MD
DTNSRDC Code 4111 (R. Gierich), Bethesda MD

DTNSRDC Code 522 (Library), Annapolis MD
 DTNSRDC PWO
 ENVIRONMENTAL PROTECTION AGENCY Reg. I Library, Boston MA; Reg. II Library, New York; Reg. III Library, Philadelphia PA; Reg. VIII, 8M-ASL, Denver CO
 FLDSUPPACT SCE, Washington DC
 FLTCOMBATRACENLANT PWO, Virginia Bch VA
 FOREST SERVICE Engr Staff Washington, DC
 GOVT. PRINT. OFF. Ziegler, Alexandria, VA
 GSA Assist Comm Des & Cnst (FAIA) D R Dibner Washington, DC ; Ch. Spec. Div./Pub. Bldg Serv., POX, Washington DC; Off of Des & Const-PCDP (D Eakin) Washington, DC
 KWAJALEIN MISRAN BMDSC-RKL-C
 LIBRARY OF CONGRESS Washington, DC (Sciences & Tech Div)
 MARCORPS 1ST Dist., Director
 MARCORPS AIR/GND COMBAT CTR LT M. Perry, Twentynine Palms CA; PWO, Twentynine Palms CA
 MARINE CORPS BASE Base Maint. Dept, Camp Lejeune, NC; Code 4.01 (Asst Chief Engr) Camp Pendleton, CA; Code 406, Camp Lejeune, NC; Maint Off Camp Pendleton, CA; PWD - Maint. Control Div. Camp Butler, Kawasaki, Japan; PWO Camp Lejeune NC; PWO, Camp Lejeune, NC; PWO, Camp Pendleton CA; PWO, Camp S. D. Butler, Kawasaki Japan
 MARINE CORPS HQS Code LFF-2, Washington DC
 MCAS Code 44, Cherry Point NC; Facil. Engr. Div. Cherry Point NC; CO, Kaneohe Bay HI; Code 1JF El Toro, Santa Ana, CA; Code S4, Quantico VA; Fac Offr, Iwakuni JA; Facs Maint Dept - Operations Div, Cherry Point; PWD - Engr Div (Code 3JD) Yuma, AZ; PWD - Utilities Div, Iwakuni, Japan; PWO, Iwakuni, Japan; PWO, Yuma AZ; SCE, Futema Japan
 MCDEC Base Maint. Ofr, Quantico, VA; NSAP REP, Quantico VA
 MCLB B520, Barstow CA; Maintenance Officer, Barstow, CA; PWO, Barstow CA
 MCRD PWO, San Diego Ca
 NAF PWD - Engr Div, Atsugi, Japan; PWO, Atsugi Japan; PWO, Mount Clemens MI
 NALF OINC, San Diego, CA
 NARF Code 100, Cherry Point, NC; Code 612, Jax, FL; Code 640, Pensacola FL
 NAS Asst PWO, Glenview, IL; CO, Guantanamo Bay Cuba; Chief of Police, Kingsville TX; Code 114, Alameda CA; Code 183 (Fac. Plan BR MGR); Code 183, Jacksonville FL; Code 183P (J. Howald), Corpus Christi TX; Code 18700, Brunswick ME; Code 18A, Miramar, San Diego CA; Code 18U (ENS P.J. Hickey), Corpus Christi TX; Code 70, Atlanta, Marietta GA; Code 8E, Patuxent Riv., MD; Dir of Engrng, PWD, Corpus Christi, TX; Dir. Util. Div., Bermuda; Grover, PWD, Patuxent River, MD; Lakehurst, NJ; Lead. Chief. Petty Offr. PW/Self Help Div, Beeville TX; PW (J. Maguire), Corpus Christi TX; PWD - Engr Div Dir, Millington, TN; PWD - Engr Div, Kingsville, TX; PWD - Engr Div, Oak Harbor, WA; PWD - Maint & Control Div, South Weymouth, MA; PWD - Maint Control Div, Glenview, IL; PWD - Maint Control Div, Moffett Field, CA; PWD Maint. Cont. Dir., Fallon NV; PWD Maint. Div., New Orleans, Belle Chasse LA; PWD, Maintenance Control Dir., Bermuda; PWO (Code 18.2), Bermuda; PWO Belle Chasse, LA; PWO Chase Field Beeville, TX; PWO Jacksonville, FL; PWO Patuxent River MD; PWO Point Mugu, CA; PWO Sigonella Sicily; PWO Whidbey Is. Oak Harbor WA; PWO Whiting Fld, Milton FL; PWO, Aux Fallon, NV; PWO, Cecil Field FL; PWO, Corpus Christi TX; PWO, Cubi Point, R.P.; PWO, Dallas TX; PWO, Glenview IL; PWO, Lakehurst NJ; PWO, Millington TN; PWO, Miramar, San Diego CA; PWO, Oceana, Virginia Bch VA; PWO, Patuxent River MD; PWO, So. Weymouth MA; ROICC Key West FL; SCE Norfolk, VA; SCE Norfolk, VA; SCE Pensacola, FL; SCE, Alameda CA; SCE, Barbers Point HI; SCE, Guantanamo Bay Cuba
 NATL ACADEMY OF SCIENCES R S Shane (Nat'l Mat'l Adv Bd) Springfield, VA
 NATL RESEARCH COUNCIL Naval Studies Board, Washington DC
 NAVACT PWO, London UK
 NAVAEROSPREGMEDCEN SCE, Pensacola FL
 NAVAIRDEVEN Chmielewski, Warminster, PA; OIC/ROICC, Warminster PA; PWD, Engr Div Mgr, Warminster, PA
 NAVAIRENGCEN Code 18 (PWO) Lakehurst, NJ
 NAVAIRSYSCOM Code NAIR 4012, Washington DC
 NAVAUDSVCHQ Director, Falls Church VA
 NAVCOASTSYSCEN CO, Panama City FL; Code 715 (J Quirk) Panama City, FL; Library Panama City, FL; PWO Panama City, FL
 NAVCOMMAREAMSTRSTA PWO, Norfolk VA; SCE Unit 1 Naples Italy; SCE, Guam; SCE, Wahiawa HI; Sec Offr, Wahiawa, HI
 NAVCOMMSTA Code 401 Nea Makri, Greece; Library, Diego Garcia Island; OICC, Nea Makri Greece; PWO Nea Makri, Greece; PWO, Fort Amador Panama Canal
 NAVCOMMUNIT Power Plant - Cutler, East Machias, ME
 NAVCONSTRACEN CO, Port Hueneme CA; Co, Gulfport MS; Curriculum/Instr. Stds Offr, Gulfport MS
 NAVDET PWO, Souda Bay Crete
 NAVDIVESALVCEN CO, Panama City FL
 NAVEDTRAPRODEVEN SCE, Pensacola FL; Technical Library, Pensacola, FL

NAVEDUTRACEN Engr Dept (Code 42) Newport, RI; PWO Newport RI
 NAVEXSYSYSCOM Code ELEX 103 NAVFACENGCOORD, Washington, DC; Elex 01F, Washington DC
 NAVENENVSA Code 11 Port Hueneme, CA; Code 111A (Winters) Port Hueneme CA
 NAVEODTECHCEN Code 605, Indian Head MD
 NAVFAC CO (Code N67), Argentia Newfoundland; M & O Officer Bermuda; PWO Pacific Beach WA; PWO,
 Antigua; PWO, Brawdy Wales UK; PWO, Centerville Bch, Ferndale CA; PWO, Coos Head, Charleston
 OR; PWO, Point Sur, Big Sur CA; SCE
 NAVFACENGCOM Code 03 Alexandria, VA; Code 03T (Essoglou) Alexandria, VA; Code 043 Alexandria,
 VA; Code 044 Alexandria, VA; Code 04B3 Alexandria, VA; Code 051A Alexandria, VA; Code 09M54,
 Technical Library, Alexandria, VA; Code 1113, Alexandria, VA; Code 111A Alexandria, VA; Code 111B
 Alexandria VA; Morrison Yap, Caroline Is.; OICC Field Office Ponape, ECI; OICC Field Office Ponape,
 ECI; ROICC Code 495 Portsmouth VA; code 08T Alexandria, VA
 NAVFACENGCOM - CHES DIV. CO, Washington DC; Code 10/11 Washington DC; Code 403 Washington
 DC; Code 406 Washington DC; FPO-1 Washington, DC; Library, Washington, D.C.
 NAVFACENGCOM - LANT DIV. Code 04 Norfolk VA Norfolk VA; Code 111, Norfolk, VA; Code 401 -
 Arch. Br., Norfolk, VA; Code 403, Norfolk, VA; Eur. BR Deputy Dir. Naples Italy; Library, Norfolk, VA;
 RDT&ELO 102A, Norfolk, VA
 NAVFACENGCOM - NORTH DIV. Asst. Dir., Great Lakes IL; Code 04 Philadelphia, PA; Code 04
 Philadelphia, PA; Code 09P Philadelphia PA; Code 1028, RDT&ELO, Philadelphia PA; Code 11, Phila PA;
 Code 111 Philadelphia, PA; Code 4012/AB (A. Bianchi) Philadelphia, PA; Code III WFT (Tayler), Phila
 PA; Library, Philadelphia, PA; ROICC, Contracts, Crane IN
 NAVFACENGCOM - PAC DIV. (Kyi) Code 101, Pearl Harbor, HI; CODE 09P PEARL HARBOR HI; Code
 04 Pearl Harbor HI; Code 11 Pearl Harbor HI; Code 402, RDT&E, Pearl Harbor HI; Commander, Pearl
 Harbor, HI; Library, Pearl Harbor, HI
 NAVFACENGCOM - SOUTH DIV. CO, Charleston SC; Code 04, Charleston, SC; Code 11, Charleston, SC;
 Code 403, Gaddy, Charleston, SC; Code 406 Charleston, SC; Code 90, RDT&ELO, Charleston SC; Library,
 Charleston, SC; ROICC (LCDR J.B. Venable) Kingsland, CA
 NAVFACENGCOM - WEST DIV. AROICC, Contracts, Twentynine Palms CA; Asst Dir, San Diego Branch;
 Code 04, San Bruno, CA; Code 04B San Bruno, CA; Code 1121 San Bruno, CA; Contracts, AROICC,
 Lemoore CA; Library, San Bruno, CA; O9P/20 San Bruno, CA; RDT&ELO Code 2011 San Bruno, CA;
 Seattle Br. Dir., Seattle WA
 NAVFACENGCOM CONTRACT AROICC, Adak, AK; AROICC, Code 1042.2, Vallejo CA; AROICC,
 NAVSTA Brooklyn, NY; AROICC, Quantico, VA; Dir, Eng. Div., Exmouth, Australia; Dir. of Constr,
 Tupman, CA; ENS J. Bank, Guam; Eng Div dir, Southwest Pac, Manila, PI; OICC Mid Pacific, Pearl
 Harbor HI; OICC Trident, Alexandria VA; OICC, Guam; OICC, Madrid, Spain; OICC, Southwest Pac,
 Manila, PI; OICC-ROICC, NAS Oceana, Virginia Beach, VA; OICC/ROICC, Balboa Panama Canal;
 OICC/ROICC, MCAS, Cherry Point, NC; R40 AROICC Puget Sound Shpyd; ROICC AF Guam; ROICC,
 Keflavik, Iceland; ROICC, NAS, Corpus Christi, TX; ROICC, Pacific, San Bruno CA; ROICC-OICC-SPA,
 Norfolk, VA
 NAVHOSP PWD - Engr Div, Beaufort, SC
 NAVINACTSHIPSTORFAC PWO, Orange TX
 NAVMAG PWD - Engr Div, Guam; SCE, Subic Bay, R.P.
 NAVMEDRSCHU 3 PWO, Cairo U.A.R
 NAVOCEANSYSCEN Code 4473 Bayside Library, San Diego, CA; Code 4473B (Tech Lib) San Diego, CA;
 Code 523 (Hurley), San Diego, CA; Code 6700, San Diego, CA; Code 811 San Diego, CA
 NAVORDMISTESTFAC Fac Supp Div, White Sands Missile Range, NM; PWD - Engr Dir, White Sands, NM
 NAVORDSTA MDS-25, Mfg Tech Dept Louisville, KY; PWO, Louisville KY
 NAVPETOFF Code 30, Alexandria VA
 NAVPETRES Director, Washington DC
 NAVPGSCOL Code 69 (T. Sarpkaya), Monterey CA; PWO Monterey CA
 NAVPHIBASE CO, ACB 2 Norfolk, VA; Code S3T, Norfolk VA; OICC/ROICC, Norfolk, VA; PWO Norfolk,
 VA; SCE Coronado, SD,CA
 NAVRADSTA PWO Jim Creek, Oso WA
 NAVREGMEDCEN Chief, PW Service Philadelphia, PA; Code 3041, Memphis, Millington TN; PWD - Engr
 Div, Camp Lejeune, NC; PWD - Maint Control Div, Camp Pendleton, CA; PWO - Engr Div, Camp
 Lejeune, NC; PWO Newport RI; PWO, Camp Lejeune NC
 NAVREGMEDCEN PWO, Okinawa, Japan
 NAVREGMEDCEN SCE; SCE San Diego, CA; SCE, Camp Pendleton CA
 NAVREGMEDCEN SCE, Great Lakes IL
 NAVREGMEDCEN SCE, Guam; SCE, Long Beach CA; SCE, Oakland CA
 NAVREGMEDCEN SCE, Yokosuka, Japan
 NAVSCOLCECOFF C35 Port Hueneme, CA
 NAVSCSOL PWO, Athens GA
 NAVSEASYSYSCOM Code 0325, Program Mgr, Washington, DC; Code 03314, Wash. D C; Code PMS 395 A 3,
 Washington, DC; SEA 04E (L Kess) Washington, DC; SEA-070C, Washington, DC

NAVSECGRUACT PWO Winter Harbor ME; PWO, Adak AK; PWO, Edzell Scotland; PWO, Puerto Rico; PWO, Torri Sta, Okinawa

NAVSHIPREPFAC SCE, Guam

NAVSHIPYD Code 202.4, Long Beach CA; Code 202.5 (Library) Puget Sound, Bremerton WA; Code 380, Portsmouth, VA; Code 382.3, Pearl Harbor, HI; Code 400, Puget Sound; Code 440 Portsmouth NH; Code 440, Norfolk; Code 440, Puget Sound, Bremerton WA; Code 440.1 (R. Schwinck), Long Beach, CA; Code 444, (Wgt Handling Engr) Philadelphia, PA; Code 453 (Util. Supr), Vallejo CA; Code 457 (Maint. Supr.) Mare Island, Vallejo CA; LTJG R. Lloyd, Vallejo CA; Library, Portsmouth NH; PW Dept, Long Beach, CA; PWD (Code 420) Dir Portsmouth, VA; PWD (Code 450-HD) Portsmouth, VA; PWD (Code 453-HD) SHPO 03, Portsmouth, VA; PWD - Asst PWO, Code 410, Vallejo, CA; PWD - Utilities Supt, Code 903, Long Beach, CA; PWO, Bremerton, WA; PWO, Mare Is.; PWO, Portsmouth NH; PWO, Puget Sound; Tech Library, Vallejo, CA; Utilities & Energy Cons. Mgr Code 108.1, Pearl Harbor, HI

NAVSTA Adak, AK; CO, Brooklyn NY; Code 16P, Keflavik, Iceland; Code 4, 12 Marine Corps Dist, Treasure Is., San Francisco CA; Dir Engr Div, PWD, Mayport FL; Dir Mech Engr 37WC93 Norfolk, VA; Engr. Dir., Rota Spain; Long Beach, CA; Maint. Cont. Div., Guantanamo Bay Cuba; Maint. Control Div., Adak; Maint. Div. Dir/Code 531, Rodman Panama Canal; Maintenance Div., Rota, Spain; PWD - Engr Dept, Adak, AK; PWD - Engr Div, Midway Is.; PWD - Engr. Div, Keflavik; PWD, Utilities Div., Guantanamo Bay Cuba; PWO, Adak, AK; PWO, Brooklyn NY; PWO, Keflavik Iceland; PWO, Mayport FL; SCE, Guam; SCE, Pearl Harbor HI; SCE, San Diego CA; Utilities Engr Off. Rota Spain

NAVSUBASE ENS S. Dove, Groton, CT; PWO

NAVSUPPACT CO, Naples, Italy; PWO Naples Italy; PWO, New Orleans LA; SCE, Long Beach CA; SCE, Mare Is., Vallejo CA

NAVSUPPFAC PWD - Maint. Control Div, Thurmont, MD; PWO, Thurmont MD

NAVSUPPO PWO, La Maddalena, Italy; Security Offr, Sardinia

NAVSURFWPCEN Commander, Dahlgren, VA; PWO, White Oak, Silver Spring, MD; Security Offr, Silver Spring MD

NAVTECHTRACEN Code N213 Orlando FL; SCE, Pensacola FL

NAVTELCOMMCOM Code 53, Washington, DC

NAVUSEAWARENGSTA Engr. Div. (Code 083) Keyport, WA; PWO, Keyport WA

NAVWARCOL Dir. of Facil., Newport RI

NAVWPNCEN Code 24 (Dir Safe & Sec) China Lake, CA; Code 2636 China Lake; Code 266, China Lake, CA; Code 26605 China Lake CA; Code 3803 China Lake, CA; Code 623 China Lake CA; PWO (Code 266) China Lake, CA; ROICC (Code 702), China Lake CA; ROICC, Code 7002, China Lake CA

NAVWPNEVALFAC Technical Library, Albuquerque NM

NAVWPNSTA (Clebak) Colts Neck, NJ; Code 092A, Seal Beach, CA

NAVWPNSTA PW Office Yorktown, VA

NAVWPNSTA PWD - Maint. Control Div., Concord, CA; PWD - Supr Gen Engr, Seal Beach, CA; PWO Colts Neck, NJ; PWO, Charleston, SC; PWO, Seal Beach CA

NAVWPNSUPPCEN Code 09 Crane IN; ENS J. Wyman, Crane IN

NAVY PAO CENTER Directory, San Diego, CA

NCTC Const. Elec. School, Port Hueneme, CA

NSC SCE, Charleston, SC

NCBC CO, Gulfport MS; Code 10 Davisville, RI; Code 15, Port Hueneme CA; Code 155, Port Hueneme CA; Code 156, Port Hueneme, CA; Code 25111 Port Hueneme, CA; Code 430 (PW Engrng) Gulfport, MS; Code 470.2, Gulfport, MS; NEESA Code 252 (P Winters) Port Hueneme, CA; PWO (Code 80) Port Hueneme, CA; PWO - Code 84, Port Hueneme, CA; PWO Gulfport, MS; PWO, Davisville RI; PWO, Gulfport, MS; Port Hueneme CA

NCBU 416 OIC, Alameda CA

NCR 20, Code R31 Gulfport, MS; 20, Code R70

NMCB 1, CO; 1, Code S3E; 133, CO; 3, CO; 4, CO; 5, CO; 62, CO; 74, ENS Vesely; FIVE, Operations Dept; THREE, Operations Off.

NOAA (Dr. T. Mc Guinness) Rockville, MD; Library Rockville, MD

NRL Code 5800 Washington, DC; Code 6620 (Faraday), Wash., DC

NSC Code 09A Security Offr, Norfolk, VA; Code 54.1 Norfolk, VA; Code 703 (J. Gammon) Pearl Harbor, HI; SCE (Code 70), Oakland CA; SCE Norfolk, VA; SCE, Guam

NSD PWD - Engr Div, Guam; SCE, Subic Bay, R.P.

NSWSES Code 0150 Port Hueneme, CA

NTC SCE, San Diego CA

NTIS Lehmann, Springfield, VA

NUSC Code 131 New London, CT; Code 3009 (CDR O. Porter) Newport, RI; Code 4111 (R B MacDonald) New London CT; Code 4123 New London, CT; Code EA123 (R.S. Munn), New London CT; Code SB 331 (Brown), Newport RI; PWO AUTEK West Palm Bch Det. West Palm Beach, FL; PWO New London, CT; PWO Newport, RI; SB322 (Tucker), Newport RI

OFFICE SECRETARY OF DEFENSE DASD (I&H) IC Pentagon; OASD (MRA&L) Dir. of Energy, Pentagon, Washington, DC

ONR Code 221, Arlington VA; Code 700F Arlington VA; LCDR Williams, Boston, MA; Nelson, Arlington, VA
 PACMISRFAC HI Area Bkg Sands, PWO Kekaha, Kauai, HI
 PERRY OCEAN ENG R. Pellen, Riviera Beach, FL
 PHIBCB 1 P&E, San Diego, CA
 PMTC Code 3331 (S. Opatowsky) Point Mugu, CA; Pat. Counsel, Point Mugu CA; Security Offr. Point Mugu CA
 PWC CO Norfolk, VA; CO Yokosuka, Japan; CO, (Code 10), Oakland, CA; CO, Great Lakes IL; CO, Pearl Harbor HI; CO, San Diego CA; CO, Subic Bay, R.P.; Code 10, Great Lakes, IL; Code 101, San Diego, CA; Code 105 Oakland, CA; Code 110, Great Lakes, IL; Code 110, Oakland, CA; Code 120, Oakland CA; Code 120, San Diego CA; Code 120C, (Library) San Diego, CA; Code 154, Great Lakes, IL; Code 200 (H. Koubenec), Great Lakes IL; Code 200, Great Lakes IL; Code 240, Subic Bay, R.P.; Code 400, Great Lakes, IL; Commanding Officer, Subic Bay; Code 400, Pearl Harbor, HI; Code 400, San Diego, CA; Code 420, Great Lakes, IL; Code 420, Oakland, CA; Code 420, Pensacola, FL; Code 420, San Diego, CA; Code 424, Norfolk, VA; Code 500 Norfolk, VA; Code 500, Great Lakes, IL; Code 500, Oakland, CA; Code 505A Oakland, CA; Code 600, Great Lakes, IL; Code 610, San Diego Ca; Code 700, Great Lakes, IL; Code 800, San Diego, CA; Library, Pensacola, FL; Library, Guam; Library, Norfolk, VA; Library, Subic Bay, R.P.; Library, Pearl Harbor, HI; Maint. Control Dept (R. Fujii) Pearl Harbor, HI; Production Officer, Norfolk, VA; Util Dept (R Pascua) Pearl Harbor, HI
 SPCC PWD - Maint. Control Div, Mechanicsburg, PA; PWO (Code 120) Mechanicsburg PA
 SUPANX PWO, Williamsburg VA
 TVA Smelser, Knoxville, Tenn.; Solar Group, Arnold, Knoxville, TN
 AF HQ USAF/DEE, Ramstein GE
 U.S. MERCHANT MARINE ACADEMY Kings Point, NY (Reprint Custodian)
 US FORCES, JAPAN Nakahara Honshu; Petroleum Staff Officer Yokota AB
 USAF REGIONAL HOSPITAL Fairchild AFB, WA
 USCG (Smith), Washington, DC; G-DMT-3/54 (D Scribner) Washington DC; G-MMT-4/82 (J Spencer)
 USCG ACADEMY Utilities Section New London, CT
 USCG R&D CENTER D. Motherway, Groton CT; Tech Dir, CT
 USDA Forest Service Reg 3 (R. Brown) Albuquerque, NM; Forest Service Reg 6 Hendrickson, Portland, OR; Forest Service, Region 1, Missoula, MT; Forest Service, Region 4, Ogden, UT; Forest Service, Region 5, San Francisco, CA; Forest Service, Region 8, Atlanta, GA; Forest Service, Region 9, Milwaukee, WI; Forest Service, San Dimas, CA
 USNA Ch. Mech. Engr. Dept Annapolis MD; ENGRNG Div, PWD, Annapolis MD; Energy-Environ Study Grp, Annapolis, MD; Environ. Prot. R&D Prog. (J. Williams), Annapolis MD; Mech. Engr. Dept. (C. Wu), Annapolis MD; NAVSYSENGR Dept, Annapolis, MD; PWD Suprt, Annapolis MD
 USS FULTON WPNS Rep. Offr (W-3) New York, NY
 TENNESSEE VALLEY AUTHORITY (Henshaw), Knoxville, TN
 ALABAMA ENERGY MGT BOARD Montgomery, AL
 ARIZONA Kroelinger Tempe, AZ; State Energy Programs Off., Phoenix AZ
 AUBURN UNIV. Bldg Sci Dept, Lechner, Auburn, AL
 BATTELLE PNW Labs (R Barchet) Richland WA
 BERKELEY PW Engr Div, Harrison, Berkeley, CA
 BONNEVILLE POWER ADMIN Portland OR (Energy Conserv. Off., D. Davey)
 BROOKHAVEN NATL LAB M. Steinberg, Upton NY
 CALIFORNIA STATE UNIVERSITY LONG BEACH, CA (CHELAPATI)
 CORNELL UNIVERSITY Ithaca NY (Serials Dept, Engr Lib.)
 DAMES & MOORE LIBRARY LOS ANGELES, CA
 DRURY COLLEGE Physics Dept, Springfield, MO
 FLORIDA ATLANTIC UNIVERSITY Boca Raton, FL (McAllister)
 FOREST INST. FOR OCEAN & MOUNTAIN Carson City NV (Studies - Library)
 FRANKLIN INSTITUTE M. Padusis, Philadelphia PA
 GEORGIA INSTITUTE OF TECHNOLOGY (LT R. Johnson) Atlanta, GA; Col. Arch, Benton, Atlanta, GA
 HARVARD UNIV. Dept. of Architecture, Dr. Kim, Cambridge, MA
 HAWAII STATE DEPT OF PLAN. & ECON DEV. Honolulu HI (Tech Info Ctr)
 ILLINOIS Pollution Control Bd, Chicago, IL
 IOWA STATE UNIVERSITY Dept. Arch, McKrown, Ames, IA
 WOODS HOLE OCEANOGRAPHIC INST. Woods Hole MA (Winget)
 KEENE STATE COLLEGE Keene NH (Cunningham)
 LEHIGH UNIVERSITY BETHLEHEM, PA (MARINE GEOTECHNICAL LAB., RICHARDS); Bethlehem PA (Linderman Lib. No.30, Flecksteiner)
 LOUISIANA DIV NATURAL RESOURCES & ENERGY Div Of R&D, Baton Rouge, LA
 MAINE OFFICE OF ENERGY RESOURCES Augusta, ME
 MISSOURI ENERGY AGENCY Jefferson City MO
 MIT Cambridge MA (Rm 10-500, Tech. Reports, Engr Lib.); Cambridge, MA (Harleman)
 MONTANA ENERGY OFFICE Anderson, Helena, MI

NATURAL ENERGY LAB Library, Honolulu, HI
 NEW HAMPSHIRE Concord NH (Governor's Council on Energy)
 NEW MEXICO SOLAR ENERGY INST. Dr. Zwibel Las Cruces NM
 NY CITY COMMUNITY COLLEGE BROOKLYN, NY (LIBRARY)
 NYS EMERGENCY FUEL OFFICE Albany NY (Butler)
 NYS ENERGY OFFICE Albany, NY; Library, Albany NY
 PENNSYLVANIA STATE UNIVERSITY STATE COLLEGE, PA (SNYDER)
 POLLUTION ABATEMENT ASSOC. Graham
 PORT SAN DIEGO Pro Eng for Port Fac, San Diego, CA
 PURDUE UNIVERSITY Lafayette, IN (CE Engr. Lib)
 RHODE IS. STATE ENERGY OFFICE Providence, RI
 CONNECTICUT Hartford CT (Dept of Plan. & Energy Policy)
 SCRIPPS INSTITUTE OF OCEANOGRAPHY LA JOLLA, CA (ADAMS)
 SEATTLE U Prof Schwaegler Seattle WA
 SOUTH DAKOTA ENERGY Off of Energy Policy (Wegman) Pierre SD
 SOUTHWEST RSCH INST King, San Antonio, TX
 SRI INTL Phillips, Chem Engr Lab, Menlo Park, CA
 STATE UNIV. OF NEW YORK Fort Schuyler, NY (Longobardi)
 STATE UNIV. OF NY AT BUFFALO School of Medicine, Buffalo, NY
 TENNESSEE ENERGY AUTHORITY Nashville, TN
 TEXAS A&M UNIVERSITY W.B. Ledbetter College Station, TX
 UNIV OF MISSOURI - ROLLA Dept Mil Sci, Rolla, MD
 UNIVERSITY OF ALASKA Doc Collections Fairbanks, AK
 UNIVERSITY OF CALIFORNIA Berkeley CA (Dept of Naval Arch.); Energy Engineer, Davis CA;
 LIVERMORE, CA (LAWRENCE LIVERMORE LAB, TOKARZ); UCSF, Physical Plant, San Francisco,
 CA
 UNIVERSITY OF DELAWARE Newark, DE (Dept of Civil Engineering, Chesson)
 UNIVERSITY OF FLORIDA Dept Arch., Morgan, Gainesville, FL
 UNIVERSITY OF HAWAII (Collen Ramage) Dept of Meteorology Honolulu HI; HONOLULU, HI
 (SCIENCE AND TECH. DIV.); Natl Energy Inst (DR Neill) Honolulu HI
 UNIVERSITY OF ILLINOIS (Hall) Urbana, IL; URBANA, IL (LIBRARY)
 UNIVERSITY OF MASSACHUSETTS (Heronemus), ME Dept. Amherst, MA
 UNIVERSITY OF NEBRASKA-LINCOLN Lincoln, NE (Ross Ice Shelf Proj.)
 UNIVERSITY OF NEW HAMPSHIRE Elec. Engr. Depot, Dr. Murdoch, Durham, N.H.
 UNIVERSITY OF PENNSYLVANIA (Inst Env Med) Philadelphia, PA
 UNIVERSITY OF TEXAS Inst. Marine Sci (Library), Port Arkansas TX
 UNIVERSITY OF TEXAS AT AUSTIN AUSTIN, TX (THOMPSON)
 UNIVERSITY OF WASHINGTON SEATTLE, WA (APPLIED PHYSICS LAB, SANDWITTH); Seattle WA
 (CE Dept FX-10,B. Hartz); Seattle WA (E. Linger)
 UNIVERSITY OF WISCONSIN Milwaukee WI (Ctr of Great Lakes Studies)
 VENTURA COUNTY Plan Div (Francis) Ventura, CA
 ARVID GRANT OLYMPIA, WA
 ATLANTIC RICHFIELD CO. DALLAS, TX (SMITH)
 AUSTRALIA Alno, USA Meradcom Ft. Belvoir, VA
 BECHTEL CORP. SAN FRANCISCO, CA (PHELPS)
 BROWN & ROOT Houston TX (D. Ward)
 CHEMED CORP Lake Zurich IL (Dearborn Chem. Div.Lib.)
 CHEVRON OIL FIELD RESEARCH CO. LA HABRA, CA (BROOKS)
 COLUMBIA GULF TRANSMISSION CO. HOUSTON, TX (ENG. LIB.)
 DEL MONTE Simon, Walnut Creek, CA
 DESIGN SERVICES Beck, Ventura, CA
 DILLINGHAM PRECAST F. McHale, Honolulu HI
 DIXIE DIVING CENTER Decatur, GA
 DURLACH, O'NEAL, JENKINS & ASSOC. Columbia SC
 EXXON PRODUCTION RESEARCH CO Houston, TX (Chao)
 FORD, BACON & DAVIS, INC. New York (Library)
 GULF COAST RSCH LAB. OCEAN SPRINGS, MS (LIBRARY)
 KLEIN ASSOCIATES Vincent, Salem NH
 LOCKHEED MISSILES & SPACE CO. INC. L. Trimble, Sunnyvale CA
 McDONNELL AIRCRAFT CO. (Fayman) Support Tech Dept St. Louis, MO
 MEDERMOTT & CO. Diving Division, Harvey, LA
 NEWPORT NEWS SHIPBLDG & DRYDOCK CO. Newport News VA (Tech. Lib.)
 PACIFIC MARINE TECHNOLOGY (M. Wagner) Duvall, WA
 PG&E Library, San Francisco, CA
 PORTLAND CEMENT ASSOC. Skokie IL (Rach & Dev Lab, Lib.)
 POTOMAC ENERGY GRU (Naismith) Alexandria, Va

RAYMOND INTERNATIONAL INC. E Colle Soil Tech Dept, Pennsauken, NJ
ROCKWELL INTL Energy Sys Group (R.A. Williams) Golden CO
SANDIA LABORATORIES Albuquerque, NM (Vortman); Library Div., Livermore CA
SCHUPACK ASSOC SO. NORWALK, CT (SCHUPACK)
SEATECH CORP. MIAMI, FL (PERONI)
SHANNON & WILLSON INC. Librarian Seattle, WA
SHELL DEVELOPMENT CO. Houston TX (C. Sellars Jr.)
3 M Technical Library, St. Paul, MN
TEXTRON INC BUFFALO, NY (RESEARCH CENTER LIB.)
TRW SYSTEMS REDONDO BEACH, CA (DAI)
UNITED KINGDOM LNO, USA Meradcom, Fort Belvoir, VA
UNITED TECHNOLOGIES Windsor Locks CT (Hamilton Std Div., Library)
WARD, WOLSTENHOLD ARCHITECTS Sacramento, CA
WESTINGHOUSE ELECTRIC CORP. Annapolis MD (Oceanic Div Lib. Bryan); Library, Pittsburgh PA
WM CLAPP LABS - BATTELLE DUXBURY, MA (LIBRARY)
WOODWARD-CLYDE CONSULTANTS PLYMOUTH MEETING PA (CROSS, III)
AL SMOOTS Los Angeles, CA
BERGSTROM Salem, OR
BRAHTZ La Jolla, CA
ERVIN, DOUG Belmont, CA
FISHER San Diego, Ca
KETRON, BOB Ft Worth, TX
KINERT San Diego, CA
KRUZIC, T.P. Silver Spring, MD
LAFKIN Seattle, WA
L.P. UNDERSEA San Antonio, TX
PEARSON, JON Washington, DC
BROWN & CALDWELL Saunders, E.M./Oakland, CA
STEIGER San Matei, CA
T.W. MERMEL Washington DC
UMSTEAD Poway, CA
WALTZ Livermore, CA
WHITE El Cajon, CA
WRIGLEY Salem MA

DATE
ILME