

CRREL

REPORT 82-22



US Army Corps
of Engineers

Cold Regions Research &
Engineering Laboratory

Conduction phase change beneath insulated heated or cooled structures

AD A119595

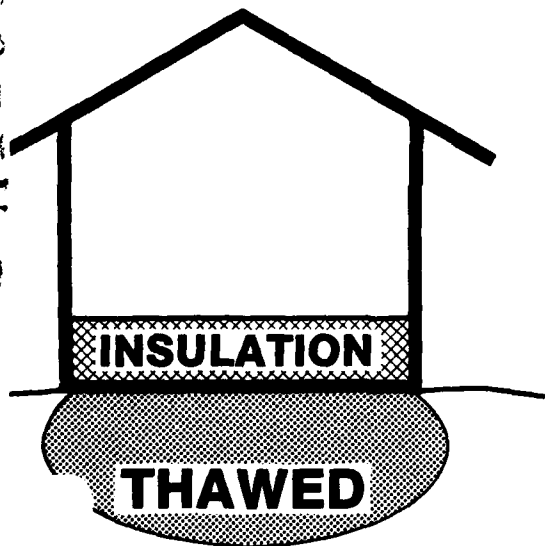

FROZEN

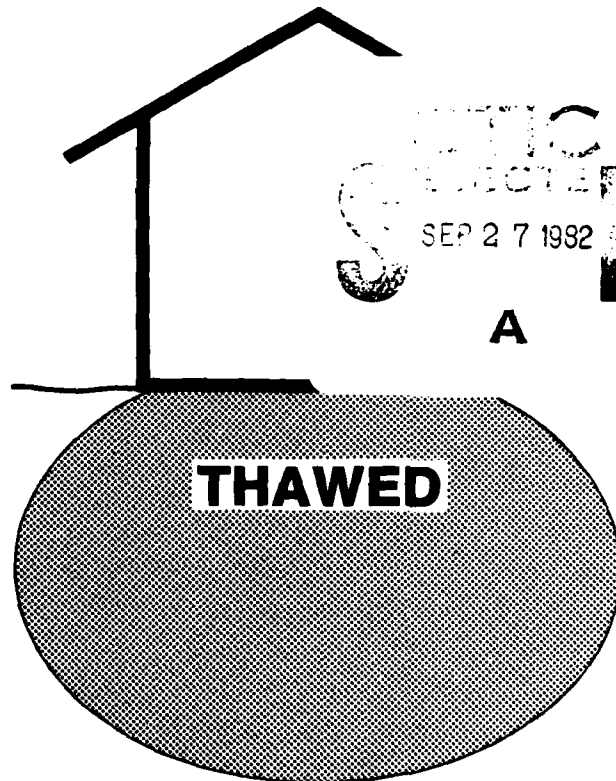

SEP 27 1982

A

FROZEN

This document has been approved
for public release and sale; its
distribution is unlimited.

This document has been approved
for public release and sale; its
distribution is unlimited.

CRREL Report 82-22

August 1982



Conduction phase change beneath insulated heated or cooled structures

Virgil J. Lunardini

Accession For	
ADIS GRA&I	<input checked="" type="checkbox"/>
ERIC TAB	<input type="checkbox"/>
Unannounced	<input type="checkbox"/>
Justification	
By	
Distribution/	
Availability Codes	
Dist	Avail and/or Special
A	



DTIC
ELECTE
S SEP 27 1982 **D**

A

Unclassified

SECURITY CLASSIFICATION OF THIS PAGE (When Data Entered)

REPORT DOCUMENTATION PAGE		READ INSTRUCTIONS BEFORE COMPLETING FORM	
1. REPORT NUMBER CRREL Report 82-22	2. GOVT ACCESSION NO. HD-A119595	3. RECIPIENT'S CATALOG NUMBER	
4. TITLE (and Subtitle) CONDUCTION PHASE CHANGE BENEATH INSULATED HEATED OR COOLED STRUCTURES		5. TYPE OF REPORT & PERIOD COVERED	
		6. PERFORMING ORG. REPORT NUMBER	
7. AUTHOR(s) Virgil J. Lunardini		8. CONTRACT OR GRANT NUMBER(s)	
9. PERFORMING ORGANIZATION NAME AND ADDRESS U.S. Army Cold Regions Research and Engineering Laboratory Hanover, New Hampshire 03755		10. PROGRAM ELEMENT, PROJECT, TASK AREA & WORK UNIT NUMBERS DA Project 4A161101A91D	
11. CONTROLLING OFFICE NAME AND ADDRESS U.S. Army Cold Regions Research and Engineering Laboratory Hanover, New Hampshire 03755		12. REPORT DATE August 1982	
		13. NUMBER OF PAGES 50	
14. MONITORING AGENCY NAME & ADDRESS (if different from Controlling Office)		15. SECURITY CLASS. (of this report) Unclassified	
		15a. DECLASSIFICATION/DOWNGRADING SCHEDULE	
16. DISTRIBUTION STATEMENT (of this Report) Approved for public release; distribution unlimited.			
17. DISTRIBUTION STATEMENT (of the abstract entered in Block 20, if different from Report)			
18. SUPPLEMENTARY NOTES			
19. KEY WORDS (Continue on reverse side if necessary and identify by block number) Conduction (Heat transfer) Phase change Thermal insulation			
20. ABSTRACT (Continue on reverse side if necessary and identify by block number) The problem of thawing beneath heated structures on permafrost (or cooled structures in non-permafrost zones) must be addressed if safe engineering designs are to be conceived. In general there are no exact solutions to the problem of conduction heat transfer with phase change for practical geometries. The quasi-steady approximation is used here to solve the conductive heat transfer problem with phase change for insulated geometries including infinite strips, rectangular buildings, circular storage tanks, and buried pipes. Analytical solutions are presented and graphed for a range of parameters of practical importance.			

DD FORM 1 JAN 73 1473

EDITION OF 1 NOV 65 IS OBSOLETE

Unclassified

SECURITY CLASSIFICATION OF THIS PAGE (When Data Entered)

PREFACE

This report was prepared by Dr. Virgil J. Lunardini, Mechanical Engineer, Applied Research Branch, Experimental Engineering Division, U.S. Army Cold Regions Research and Engineering Laboratory.

This study was conducted under DA Project 4A161101A91D, *In-House Laboratory Independent Research*.

Appreciation is expressed to Dr. Y.C. Yen, Dr. G.D. Ashton, and F.D. Haynes of CRREL for their technical review of the report.

The numerical calculations and the computer program were prepared by T. Carpenter.

CONTENTS

	Page
Abstract	i
Preface	ii
Nomenclature	iv
Introduction.....	1
Quasi-steady method.....	1
General quasi-steady relations	4
Method 1.....	5
Method 2.....	6
Semi-infinite strip	7
Method 1.....	7
Method 2.....	8
Rectangular building	9
Circular tank	10
Buried pipe	12
Conclusions	14
Literature cited	14
Appendix A	17

ILLUSTRATIONS

Figure

1. Insulated semi-infinite strip	2
2. Geometry for thaw	5
3. Steady-state temperature comparisons beneath center of strip	9
4. Geometry for a rectangular building on the ground surface.....	10
5. Circular tanks on ground surface	11
6. Geometry of insulated buried pipe	12

NOMENCLATURE

a	half width of structure or radius of tank
a_1	$\sqrt{\mu^2 - 1}$
A_1, A_2	defined by eq 9 and 11
b	half length of structure
b_1	$1/\ln(\mu + a_1)$
B_1, B_2	defined by eq 9 and 11
C	volumetric specific heat
d	insulation thickness
D	phase change thickness beneath pipe insulation
f	steady-state solution geometric function
f'	steady-state solution geometric function modified for insulation
f_0	value of f on the phase change interface
g	steady-state solution geometric function
g_0	value of g on the phase change interface
g_1	$\mu + 1$
h	depth to center of arbitrary isotherm
h_0	depth to center of buried pipe
H	h/r_i
H_0	dimensionless depth to center of phase change isotherm circle
k	thermal conductivity
k_{12}	k_1/k_2
L	volumetric latent heat of fusion
L_e	effective latent heat = $L(1 + k_{12} \beta S_T + S_T/2)$
m	outward normal from phase change interface
m'	m/a
n	b/a
M	$\beta(1 + b_1 \alpha)/(1 + \beta)$
p	distance along outward normal
p'	p/a
p_1	$\beta(\pi + 4\alpha)/(1 + \beta)$
p_2	$\sqrt{1 + \frac{a_1^2}{u^2}}$
q	heat flux from bottom of insulated structure
q_p	heat transfer rate per unit length of pipe
r	radius of arbitrary isotherm
r_1^2	$(x-x')^2 + (y-y')^2 + z^2$
r_i	outer radius of insulation
r_0	radius of pipe
R	r/r_i
R_0	dimensionless radius of phase change isotherm circle
s	distance along phase change interface
s'	s/a
S	area of phase change interface
S'	S/a^2
S_1	surface area with disturbed temperature
S_T	$\frac{C_1 (T_p - T_f)}{L}$, Stefan number

t	time
T	temperature
T_f	freezing temperature
T_0	ground initial and surface temperature
T_p	temperature of bottom of structure or pipe surface
\bar{T}_p	temperature of insulation/ground interface
u	dummy variable
V	volume of region changing phase
V'	V/a^3
x, y, z	Cartesian coordinates
x_0, y_0, z_0	Cartesian coordinates of phase change interface
α	$\left\{ \begin{array}{l} k_{li} \ln \left(\frac{r_i}{r_0} \right) \text{ insulation parameter for buried pipe} \\ k_{li} \frac{d}{2a} \text{ insulation parameter for other geometries} \end{array} \right.$
β	$k_{21} \frac{(T_f - T_0)}{(T_p - T_f)}$
γ	value of ξ_0 at center of semi-infinite strip
γ_0	value of γ for uninsulated strip ($\alpha = 0$)
γ_x	value of γ at any location ξ
γ_∞	maximum or limiting value of γ
ξ	$\left\{ \begin{array}{l} x/r_i \text{ buried pipe} \\ x/a \text{ other geometries} \end{array} \right.$
ξ_0	$\left\{ \begin{array}{l} x_0/r_i \text{ buried pipe} \\ x_0/a \text{ other geometries} \end{array} \right.$
η	y/a
η_0	y_0/a
κ	thermal diffusivity
μ	h_0/r_i
ξ	$\left\{ \begin{array}{l} z/r_i \text{ buried pipe} \\ z/a \text{ other geometries} \end{array} \right.$
ξ_0	$\left\{ \begin{array}{l} z_0/r_i \text{ buried pipe} \\ z_0/a \text{ other geometries} \end{array} \right.$
ξ_c	value of ξ_0 beneath center of circular tank
ξ_{c-}	limiting value of ξ_c
ξ_B	value of ξ_0 at center of rectangle
ξ_{B-}	limiting value of ξ_B
ξ_p	value of ξ_0 directly beneath buried pipe
ξ_{p-}	limiting value of ξ_p
ρ	dimensionless radial distance from center of phase change isotherm

$$\tau \begin{cases} \frac{k_i (T_p - T_f) t}{r_i^2 L}, \text{ dimensionless time for buried pipe} \\ \frac{2k_i S_T t}{\pi a^2}, \text{ dimensionless time for other geometries} \end{cases}$$

$$\tau^* = 2\sqrt{\tau}$$

θ polar coordinate

$$\phi = \frac{T - T_0}{T_p - T_0}$$

$$\phi_0 = \frac{T_0 - T_f}{T_p - T_f}$$

$$\phi_1 = \frac{T_1 - T_f}{T_p - T_f} = \frac{f - f_0}{1 - f_0}$$

$$\phi_2 = \frac{T_2 - T_0}{T_f - T_0} = \frac{f}{f_0}$$

$$\phi'_1 = \frac{T_1 - T_f}{T_p - T_f} = \frac{f' - f'_0}{1 - f'_0}$$

$$\phi'_2 = \frac{T_2 - T_0}{T_f - T_0} = \frac{y}{g_0}$$

Subscripts

- 1 thawed region
- 2 frozen region
- f fusion or frozen
- i insulation

CONDUCTION PHASE CHANGE BENEATH INSULATED HEATED OR COOLED STRUCTURES

Virgil J. Lunardini

INTRODUCTION

Large-scale exploration and development of the northern regions of the Northern Hemisphere have stimulated interest in a number of thermal problems. Not the least of these is the effect of heated structures on underlying or surrounding permafrost. This involves the study of conduction heat transfer in media which can undergo freezing or thawing. Lachenbruch (1957a,b, 1959) and Jumikis (1978) applied linear conduction theory to the effect of heating on permafrost. Linear theory was possible since no phase change was considered despite the direct reference to permafrost problems. However, if phase change is introduced, the conduction problem becomes non-linear and only a few exact solutions exist for the simplest geometries and boundary conditions (Lunardini 1981a).

Geometries of practical interest, such as those considered in this report, do not allow exact solutions of the thermal problem to be found. Thus closed form solutions, as opposed to numerical evaluations, have relied on approximate methods. In general two approximate methods have been quite fruitful for phase change conduction problems: the heat balance integral method, and the quasi-steady method. The heat balance integral method gives excellent accuracy and has been applied successfully to simpler geometries such as semi-infinite plane systems (Goodman 1958, Lunardini 1981c, Lunardini and Varotta 1981, Yuen 1980), and pipes buried at infinite depth (Lunardini 1980, Bell 1978).

The quasi-steady method is not as rigorous as the heat balance integral method but it can be applied to a wide variety of geometries. Applications have included uninsulated buried pipes (Hwang 1977, Thornton 1976, Porkhayev 1963), insulated buried pipes (Lunardini 1981a,b,d, Seshadri and Krishnayya 1980), and three-dimensional structures (Porkhayev 1970). Probably the most widely used calculated results are those of Porkhayev (1970). This report derives new quasi-steady relations which are applied to insulated geometries including semi-infinite strips (roads, sewers), rectangular buildings, circular storage tanks, and buried pipes. The quantitative results for insulated systems are superior to those of Porkhayev (1970).

QUASI-STEADY METHOD

The quasi-steady approximation assumes that the temperature field varies successively from one steady state to another. Let us examine the limitations of this approximation. Consider an infinite

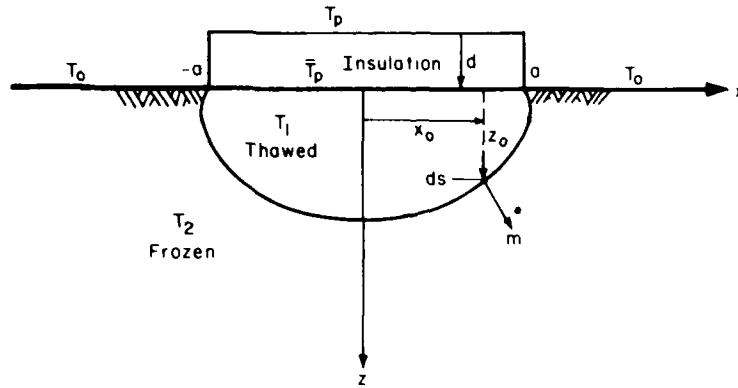

Figure 1. Insulated semi-infinite strip.

strip as shown in Figure 1. Initially the temperature is uniform at T_0 and the insulated surface of the strip jumps to T_p at time zero. The temperature beneath the strip then starts to vary with time. The properties of the material differ for regions below and above the fusion temperature T_f . The equations for the conduction heat flow problem are

$$\frac{\partial^2 T_1}{\partial x^2} + \frac{\partial^2 T_1}{\partial z^2} = \frac{1}{\kappa_1} \frac{\partial T_1}{\partial t} \quad (1)$$

$$T_1(x, 0, t) = \bar{T}_p \quad -a \leq x \leq a \quad t > 0 \quad (1a)$$

$$T_1(x_0, z_0, t) = T_f \quad (1b)$$

$$\frac{\partial^2 T_2}{\partial x^2} + \frac{\partial^2 T_2}{\partial z^2} = \frac{1}{\kappa_2} \frac{\partial T_2}{\partial t} \quad (2)$$

$$T_2(x, 0, t) = T_0 \quad x < -a \text{ or } x > +a \quad (2a)$$

$$T_2(x, z, 0) = T_0 \quad (2b)$$

$$T_2(x_0, z_0, t) = T_f \quad (2c)$$

$$\lim_{x, z \rightarrow \infty} T_2(x, z, t) \rightarrow T_0 \quad (2d)$$

If thawing is considered, the energy balance over the surface S separating the frozen and thawed zones is

$$\int_S \left(k_1 \frac{\partial T_1}{\partial m} - k_2 \frac{\partial T_2}{\partial m} \right)_{x_0, z_0} ds = -L \frac{dV}{dt} \quad (3)$$

where m is the outward normal to the interface and V the volume of the material changing phase. Equations 1-3 can be nondimensionalized using the following quantities:

$$\zeta = \frac{\lambda}{a} \quad \eta = \frac{y}{a} \quad \xi = \frac{z}{a} \quad m' = \frac{m}{a} \quad s' = \frac{s}{a^2} \quad V' = \frac{V}{a^3} \quad S' = \frac{S}{a^2}$$

$$\phi_1 = \frac{T_1 - T_f}{T_p - T_f} \quad \phi_2 = \frac{T_2 - T_0}{T_f - T_0} \quad \beta = k_{21} \frac{T_f - T_0}{T_p - T_f}$$

$$S_T = \frac{C_1 (T_p - T_f)}{L}$$

$$\tau = \frac{2\kappa_1 S_T t}{\pi a^2}$$

$$\phi_0 = \frac{T_0 - T_f}{T_p - T_f}$$

$$\frac{\partial^2 \phi_1}{\partial \zeta^2} + \frac{\partial^2 \phi_1}{\partial \xi^2} = \frac{2}{\pi} S_T \frac{\partial \phi_1}{\partial \tau} \quad (4)$$

$$\phi_1(\zeta, 0, \tau) = 1 \quad -1 < \zeta < +1 \quad (4a)$$

$$\phi_1(\zeta_0, \xi_0, \tau) = 0 \quad (4b)$$

$$\frac{\partial^2 \phi_2}{\partial \zeta^2} + \frac{\partial^2 \phi_2}{\partial \xi^2} = \frac{2S_T}{\pi k_{21}} \frac{\partial \phi_2}{\partial \tau} \quad (5)$$

$$\phi_2(\zeta, 0, \tau) = 0 \quad \zeta < -1 \text{ or } \zeta > +1 \quad (5a)$$

$$\phi_2(\zeta, \xi, 0) = 0 \quad (5b)$$

$$\phi_2(\zeta_0, \xi_0, \tau) = 1 \quad (5c)$$

$$\lim_{\zeta, \xi \rightarrow \infty} \phi_2(\zeta, \xi, \tau) = 0 \quad (5d)$$

$$\int_{S'} \left(\frac{T_p - T_f}{T_p - T_f} \frac{\partial \phi_1}{\partial m'} - \beta \frac{\partial \phi_2}{\partial m'} \right)_{\zeta_0, \xi_0} ds' = -\frac{2}{\pi} \frac{dV'}{d\tau} \quad (6)$$

Equations 4-6 cannot be solved exactly, but the diffusion equations, eq 4 and 5, reduce to the steady-state case if the Stefan number S_T is small. In this case it is not necessary to solve the transient conduction equation but only the much simpler steady-state conduction equation. For simplicity assume that the properties of the frozen and thawed media are identical. Then the quasi-steady system to be solved is

$$\frac{\partial^2 \phi}{\partial \zeta^2} + \frac{\partial^2 \phi}{\partial \xi^2} = 0 \quad (7)$$

$$\phi(\zeta, \alpha) = \begin{cases} 1 & -1 \leq \zeta \leq 1 \\ 0 & \zeta > 1 \text{ or } \zeta < -1 \end{cases} \quad (7a)$$

$$\lim_{\zeta, \xi \rightarrow \infty} \phi(\zeta, \xi) = 0. \quad (7b)$$

Notice that the initial condition cannot be satisfied and that the energy boundary equation is solved by merely substituting in the solution for ϕ . It has been shown (Lunardini 1981a) that eq 7-7b are the zeroth system of a perturbation solution of eq 4-5. The quasi-steady method then consists of solving the steady-state form of the problem and locating the phase change boundary with the use of an equation similar to eq 6. Clearly the accuracy of the quasi-steady method depends upon the magnitude of the Stefan number, which is the ratio of the sensible to the latent heat for the material. For systems with a large latent heat relative to the sensible heat it can be expected that the quasi-steady approximation will be reasonably good. This covers soil systems and many phase change materials used for latent heat storage.

The utility of the quasi-steady methods lies in the fact that for many phase change problems the equivalent steady-state solution can be written down immediately or easily found.

The solution to eq 7-7b, which is well known and will be useful, is

$$\phi = \frac{1}{\pi} \left\{ \tan^{-1} \left(\frac{1+\zeta}{\xi} \right) + \tan^{-1} \left(\frac{1-\zeta}{\xi} \right) \right\} = \frac{1}{\pi} \tan^{-1} \left(\frac{2\xi}{\zeta^2 + \xi^2 - 1} \right) = f(\zeta, \xi). \quad (8)$$

GENERAL QUASI-STEADY RELATIONS

General equations can be derived which will be valid for a class of important phase change problems. Assume that the solution to the quasi-steady form of eq 4 is

$$\phi_1 = A_1(\tau) + B_1(\tau) f(\zeta, \xi). \quad (9)$$

This will satisfy the quasi-steady form of eq 4 and, when combined with eq 4a and 4b, gives

$$\phi_1 = \frac{f-f_0}{1-f_0}. \quad (10)$$

The function f is the solution to the equivalent steady-state equations and f_0 is the value of the function on the phase change surface where the temperature is at the fusion value.

Also let

$$\phi_2 = A_2(\tau) + B_2(\tau) f(\zeta, \xi). \quad (11)$$

Then using by eq 5a and 5c,

$$\phi_2 = \frac{f}{f_0}. \quad (12)$$

Once f_0 has been determined, the total solution will be known. Equation 6 will be evaluated at only one location on the phase change boundary:

$$\frac{\bar{T}_p - T_f}{T_p - T_f} \frac{\partial \phi_1}{\partial m'} - \beta \frac{\partial \phi_1}{\partial m'} = -\frac{2}{\pi} \frac{dp}{d\tau}. \quad (13)$$

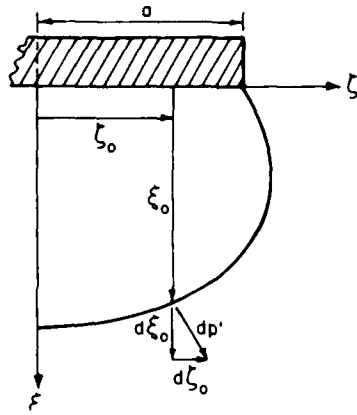

Figure 2. Geometry for thaw at (ξ_0, ξ_0) .

The relationship between dp' , the small amount of material thawed during $d\tau$, and $d\xi_0$ is shown in Figure 2:

$$dp' = \left(\sqrt{\left(\frac{\partial f}{\partial \xi}\right)^2 + \left(\frac{\partial f}{\partial \xi}\right)^2} \right)_{\xi_0} d\xi_0 \quad (14)$$

Also

$$\frac{\partial \phi}{\partial m'} = \sqrt{\left(\frac{\partial \phi}{\partial \xi}\right)^2 + \left(\frac{\partial \phi}{\partial \xi}\right)^2} \quad (15)$$

With these relations eq 13 is

$$\left(\frac{\bar{T}_p - T_f}{T_p - T_f} \frac{1}{f_0 - 1} + \frac{\beta}{f_0} \right) \left(\frac{\partial f}{\partial \xi} \right)_{\xi_0, \xi_0} = \frac{2}{\pi} \frac{d\xi_0}{d\tau} \quad (16)$$

This equation will give the vertical phase change depth as a function of time for any location ξ_0 . It will be convenient to later evaluate this equation along the plane of symmetry, $\xi = 0$.

It is necessary to consider the effect of the insulation since the temperature of the ground surface \bar{T}_p is an unknown function of time. There are several ways to handle the insulation.

Method 1

The heat flow through the insulation will be equated to the heat flow through the thawed soil at $\xi = 0$. This concept has been used by Seshradi and Krishnappa (1980) and by Lunardini (1981b):

$$-\frac{k_1}{a} (\bar{T}_p - T_f) \frac{\partial \phi_1(0,0)}{\partial \xi} = k_1 \frac{(T_p - \bar{T}_p)}{d} \quad (17)$$

From eq 10, this yields

$$\frac{\bar{T}_p - T_f}{T_p - T_f} = \frac{1}{1 - \frac{2\alpha}{1-f_0} \frac{\partial f(0,0)}{\partial \xi}} \quad (18)$$

where α is the insulation parameter given in the *Nomenclature*. The general interface equation, eq 1b, is now

$$\left(\frac{1}{t_0 - 1 + 2\alpha \frac{\partial f(0,0)}{\partial \xi}} + \frac{\beta}{t_0} \right) \left(\frac{\partial f}{\partial \xi} \right)_{\xi_0, \xi_0} = \frac{2}{\pi} \frac{d\xi_0}{d\tau} \quad (19)$$

The final, steady-state, or limiting solution occurs when $d\xi_0/d\tau = 0$ in eq 19:

$$\frac{1}{t_{0\infty} - 1 + 2\alpha \frac{\partial f(0,0)}{\partial \xi}} + \frac{\beta}{t_{0\infty}} = 0 \quad (20)$$

or

$$t_{0\infty} = \frac{\beta}{1+\beta} \left[1 - 2\alpha \frac{\partial f(0,0)}{\partial \xi} \right] \quad (21)$$

The heat flux, into the thawed soil, at the center of the heated surface is

$$q = -k_1 \left(\frac{\partial T_1}{\partial z} \right)_{x,y,z=0} \quad (22)$$

This can be written

$$q = \frac{-k_1 (T_p - T_f)}{a \left[1 - t_0 - 2\alpha \frac{\partial f(0,0)}{\partial \xi} \right]} \frac{\partial f(0,0)}{\partial \xi} \quad (23)$$

To evaluate eq 19 it is only necessary to find the appropriate, steady-state, geometric function f .

Method 2

Method 2 accounts for the effect of the insulation by considering an excess layer of soil with a thermal resistance equal to that of the actual insulation. The excess soil layer is only applied to the temperature relations of the thawed zone. The concept was introduced by Porkhayeve (1963, 1970).

The temperature equations are

$$\phi_1' = \frac{T_1 - T_f}{T_p - T_f} = \frac{f' - f_0'}{1 - f_0'} \quad (24)$$

$$\phi_2' = \frac{T_2 - T_0}{T_f - T_0} = \frac{g}{g_0} \quad (25)$$

where f' is the steady-state solution, with the excess thawed soil for insulation, and g is the usual steady-state solution. Equation 3 then becomes

$$\left\{ \frac{1}{1-f_0'} \sqrt{\left(\frac{\partial f'}{\partial \xi} \right)^2 + \left(\frac{\partial f'}{\partial \xi} \right)^2} - \frac{\beta}{g_0} \sqrt{\left(\frac{\partial g}{\partial \xi} \right)^2 + \left(\frac{\partial g}{\partial \xi} \right)^2} \right\} \left(\frac{\partial f'}{\partial \xi} \right)_{\xi_0, \xi_0} = - \frac{2}{\pi} \sqrt{\left(\frac{\partial f'}{\partial \xi} \right)^2 + \left(\frac{\partial f'}{\partial \xi} \right)^2} \frac{d\xi_0}{d\tau} \quad (26)$$

The center heat flux to the thawed soil is

$$q = - \frac{k_1 (T_p - T_f)}{a(1-f'_0)} \frac{\partial f'(0,0)}{\partial \xi} \quad (27)$$

While both methods approximate the steady-state solution when an insulation layer is present, it will be shown that the first method gives more accurate results. A more accurate approach would exactly solve the steady-state problem, probably by using complex variables with a Schwarz-Christoffel transformation, but such a method has not yet yielded convenient solutions.

The same relations apply to the freezing case if $\tau = 2k_1 (T_f - T_p) t / (-aL)$ and region 1 is the frozen layer.

It is now possible to examine, quantitatively, several practical geometries.

SEMI-INFINITE STRIP

A semi-infinite strip can represent roads, shallow rivers, or very long rectangular buildings. The geometry of the system is shown in Figure 1.

The steady-state solution is given by Lunardini (1981a)—see eq 8—and the geometric function f is

$$f = \frac{1}{\pi} \tan^{-1} \left(\frac{2\xi}{\xi^2 + \xi^2 - 1} \right) = \frac{1}{\pi} \left\{ \tan^{-1} \left(\frac{1+\xi}{\xi} \right) + \tan^{-1} \left(\frac{1-\xi}{\xi} \right) \right\} \quad (28)$$

Method 1

Using eq 28 and eq 19 the phase change interface equation is

$$d\tau = \frac{\left[(\xi_0^2 + \xi_0^2 - 1)^2 + 4\xi_0^2 \right] d\xi_0}{(\xi_0^2 - \xi_0^2 - 1) \left[\frac{1}{f_0 - 1 - \frac{4\alpha}{\pi}} + \frac{\beta}{f_0} \right]} \quad (29)$$

Thus

$$\tau = \int_0^\gamma \frac{[(\xi^2 + u^2 - 1)^2 + 4u^2] du}{(\xi^2 - u^2 - 1) \left[\frac{1}{f_0 - 1 - \frac{4\alpha}{\pi}} + \frac{\beta}{f_0} \right]} \quad (30)$$

where $f_0 = \frac{1}{\pi} \tan^{-1} \left(\frac{2u}{\xi^2 + u^2 - 1} \right)$.

The limiting interface, at $\tau = \infty$, is

$$\xi_{0\infty} = \cot p_1 + \sqrt{\cot^2 p_1 - (\xi^2 - 1)} \quad (31)$$

where $p_1 = \frac{\beta}{1+\beta} (\pi + 4\alpha)$.

Since eq 30 is valid for any location ξ , it will be convenient to evaluate the equation at $\xi = 0$. This is along the axis of symmetry for the geometry. Then

$$\tau = - \int_0^\gamma \frac{(u^2 + 1) du}{\frac{1}{f(u) - \left(1 + \frac{4\alpha}{\pi}\right)} + \frac{\beta}{f(u)}} \quad (32)$$

where $t = (2/\pi) \cot^{-1} u$, and γ is the value of ξ_0 along the axis of symmetry.

Equation 31 reduces to

$$\gamma_{\infty} = \cot \left[\frac{\beta}{\beta+1} \left(\frac{\pi}{2} + 2\alpha \right) \right]. \quad (33)$$

Since the value of t_0 is constant, the value of the thaw depth at any ζ , γ_s , can be found as a function of the centerline value γ :

$$\gamma_s = \frac{\gamma^2 - 1}{2\gamma} + \sqrt{\frac{(\gamma^2 - 1)^2}{4\gamma^2} - (\zeta^2 - 1)}. \quad (34)$$

When $\gamma < 1$, the phase change at the edge of the strip ($\zeta = 1.0$) is zero. Therefore eq 23 for the surface heat flux is

$$q = \frac{2k_1 (T_p - T_f)}{\pi a \left[1 + \frac{4\alpha}{\pi} - t_0 \right]}. \quad (35)$$

Method 2

The equations for method 2 will only be written for the axis of symmetry. Then eq 26 is

$$\tau = \int_0^{\gamma} \frac{du}{(1-t'_0) [(u+2\alpha)^2 + 1] - \frac{\beta}{g_0} (u^2 + 1)} \quad (36)$$

where

$$t'_0 = \frac{2}{\pi} \tan^{-1} \left(\frac{1}{u+2\alpha} \right); \text{ this assumes that a thaw soil layer } 2\alpha \text{ will compensate for the insulation layer}$$

$$g_0 = \frac{2}{\pi} \tan^{-1} \left(\frac{1}{u} \right).$$

The limiting solution is

$$\frac{1}{(1-t'_0) [(\gamma_{\infty} + 2\alpha)^2 + 1]} = \frac{\beta}{g_0 (\gamma_{\infty}^2 + 1)} \quad (37)$$

The solutions of methods 1 and 2 are identical for uninsulated strips ($\alpha = 0$) but they differ if the strip is insulated. Since an exact solution to this problem is not available, the steady-state solutions were compared to a numerical finite-difference calculation. Figure 3 shows the steady-state centerline temperatures for $\alpha = 0.6$, $\beta = 0.7$. Clearly the temperatures predicted by method 1 are superior to those of method 2. Note also that the depth of the thaw zone predicted by method 1 is considerably more accurate than that of method 2. All of the quantitative results were calculated with method 1 due to its superior accuracy.

Equation 32 can be evaluated exactly if $\beta = 0$. For this case

$$\tau = \left(1 + \frac{4\alpha}{\pi} \right) \left(\frac{\gamma^3}{3} + \gamma \right) - \frac{2}{\pi} \left\{ \left(\frac{\gamma^3}{3} + \gamma \right) \cot^{-1} \gamma + \frac{1}{3} \ln(1+\gamma^2) + \frac{1}{6} \gamma^2 \right\} \quad (38)$$

Equation 32 was evaluated numerically and plotted as Figures A1-A12. Equation 31 is plotted as Figures A13-A15 for various values of ζ .

The temperatures in the thawed and frozen zones can be found with eq 10 and 12.

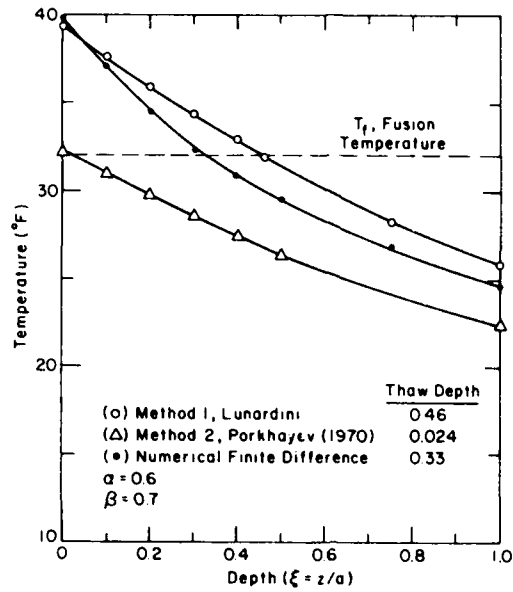

Figure 3. Steady-state temperature comparisons beneath center of strip.

RECTANGULAR BUILDING

While the semi-infinite strip can represent a building with a very large length/width ratio, it is useful to have solutions for any aspect ratio. The geometry for such solutions is as shown in Figure 4.

The steady-state solution is given by Lunardini (1981a) and the geometric factor is

$$f = \frac{1}{2\pi} \left\{ \tan^{-1} \frac{(\zeta+1)(\eta+n)}{\xi \sqrt{\xi^2 + (\zeta+1)^2 + (\eta+n)^2}} - \tan^{-1} \frac{(\zeta-1)(\eta+n)}{\xi \sqrt{\xi^2 + (\zeta-1)^2 + (\eta+n)^2}} \right. \\ \left. - \tan^{-1} \frac{(\zeta+1)(\eta-n)}{\xi \sqrt{\xi^2 + (\zeta+1)^2 + (\eta-n)^2}} + \tan^{-1} \frac{(\zeta-1)(\eta-n)}{\xi \sqrt{\xi^2 + (\zeta-1)^2 + (\eta-n)^2}} \right\} \quad (39)$$

where $n = b/a$ is the aspect ratio.

The calculations will be carried out along the axis of symmetry, $\zeta = \eta = 0$, and the geometric function can be written as

$$f(\xi) = \frac{2}{\pi} \tan^{-1} \left(\frac{n}{\xi \sqrt{\xi^2 + 1 + n^2}} \right) \quad (40)$$

Equation 19, for the phase change interface, is now

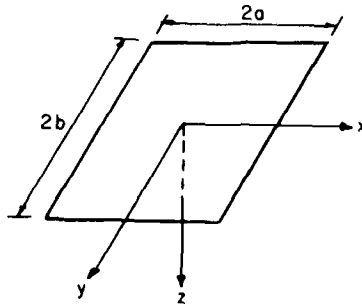

Figure 4. Geometry for a rectangular building on the ground surface.

$$\tau = -\frac{1}{n} \int_0^{\xi_B} \frac{[u^2(u^2+1+n^2)+n^2] \sqrt{u^2+1+n^2} du}{(2u^2+1+n^2) \left[\frac{1}{f_0-1 - \frac{4\alpha\sqrt{1+n^2}}{\pi n}} + \frac{\beta}{f_0} \right]} \quad (41)$$

where

$$f_0 = \frac{2}{\pi} \tan^{-1} \left(\frac{n}{u\sqrt{u^2+1+n^2}} \right)$$

As the aspect ratio n becomes large, eq 41 will reduce to eq 32 for the infinite strip. Thus the infinite strip is represented by eq 41 when the aspect ratio is large.

The limiting or steady-state solution is

$$\xi_{B\infty} = \left\{ \sqrt{\left(\frac{1+n^2}{2}\right)^2 + n^2 \cot^2 \left[\frac{\beta}{1+\beta} \left(\frac{\pi}{2} + \frac{2\alpha\sqrt{1+n^2}}{n} \right) \right]} - \frac{(1+n^2)}{2} \right\}^{1/2} \quad (42)$$

Numerical quadrature of eq 41 leads to the plots given by Figures A16-A51 for $n = 1, 2, 3$. The limiting steady-state values are given in Figures A52-A60.

CIRCULAR TANK

Storage tanks are often used in cold climates. The solution for a circular tank, shown in Figure 5, follows in the same way as for the other geometries.

The transient solution for the temperature in a semi-infinite medium initially at T_0 after a surface area S_1 is disturbed with a temperature T_p is given by Lachenbruch (1957a) as

$$\frac{T-T_0}{T_p-T_0} = \frac{z}{2\pi} \iint_{S_1} \left[\frac{e^{-r_1^2/4\kappa t}}{\sqrt{\pi\kappa t}} + \operatorname{erfc} \left\{ \frac{r_1}{2\sqrt{\kappa t}} \right\} \right] \frac{dA}{r_1^3} \quad (43)$$

where $r_1^2 = (x-x')^2 + (y-y')^2 + z^2$ and x', y' = coordinates of dA in S_1 .

The steady-state solution, $t \rightarrow \infty$, reduces to

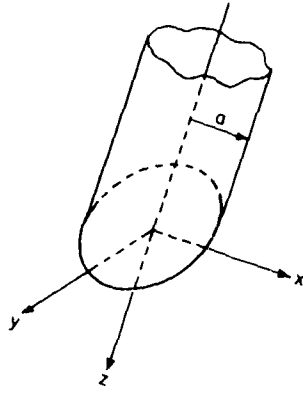

Figure 5. Circular tank on ground surface.

$$\frac{T - T_0}{T_p - T_0} = \frac{z}{2\pi} \iint_{S_1} \frac{dA}{r_1^3} \quad (44)$$

Equation 44 can be integrated for certain simple geometries such as the infinite strip or the rectangular area already discussed. A general solution for the circle is not available but the temperature along the z -axis, $x = y = 0$, can be written immediately:

$$\frac{T - T_0}{T_p - T_0} = 1 - \frac{z}{\sqrt{z^2 + a^2}} \quad (45)$$

The geometric function for this case is then

$$f(\xi) = 1 - \frac{\xi}{\sqrt{\xi^2 + 1}} \quad (46)$$

Equation 19 for the phase change interface depth can then be written for the area along the axis of symmetry ξ :

$$\tau = -\frac{2}{\pi} \int_0^{\xi_c} \frac{(u^2 + 1)^{3/2} du}{\frac{1}{f(u) - 1 - 2\alpha} + \frac{\beta}{f(u)}} \quad (47)$$

where $f(u) = 1 - \frac{u}{\sqrt{u^2 + 1}}$. (48)

Equation 47 is plotted in Figures A61-A72 for various values of α and β . The limiting solution, plotted as Figure A73, is

$$\xi_{c\infty} = \frac{1}{\sqrt{\left(\frac{1+\beta}{1-2\alpha\beta}\right)^2 - 1}} \quad (49)$$

$$\left(\frac{1}{1+b_1\alpha-r_0} - \frac{\beta}{r_0} \right) \int_{-\pi/2}^{\pi/2} \left(\frac{\partial f}{\partial \rho} \right)_{\rho=R_0} d\theta = -\pi \frac{dR}{dt} \quad (55)$$

If the heat flux is assumed to be constant around the entire phase change interface, using the value at the bottom of the pipe where $\theta = \pi/2$, then

$$\left(\frac{\partial f}{\partial \rho} \right)_{\rho=R_0} = \frac{a_1 b_1}{R_0 (H_0 + R_0)}$$

From eq 55 the phase change radius is governed by

$$a_1 b_1 \tau = \int_1^{R_0} \frac{u^2 (p_2 + 1) du}{\frac{1}{1+b_1\alpha-r_0} - \frac{\beta}{r_0}} \quad (56)$$

where

$$r_0 = b_1 \ln(p_2 + \sqrt{p_2^2 - 1})$$

$$p_2 = \sqrt{1 + \frac{a_1^2}{u^2}}$$

Equation 56 can also be written as

$$4a_1 \tau = \int_{\mu+1}^{\xi_p} \frac{(u^4 - a_1^4) du}{u^2 \left[\frac{1}{\frac{1}{b_1} + \alpha - \ln\left(\frac{u+a_1}{u-a_1}\right)} - \frac{\beta}{\ln\left(\frac{u+a_1}{u-a_1}\right)} \right]} \quad (57)$$

The solution to eq 57, when $\beta = 0$, is

$$4a_1 \tau = \left(\frac{\xi_p^3}{3} + \frac{a_1^4}{\xi_p} \right) \ln \left[\frac{(\mu+a_1)(\xi_p-a_1)}{\xi_p+a_1} \right] + \alpha \left[\frac{1}{3} (\xi_p^3 - g_1^3) + a_1^4 \left(\frac{1}{\xi_p} - \frac{1}{g_1} \right) \right] \\ - \frac{a_1}{3} (\xi_p^2 - g_1^2) + 2a_1^3 \ln \left(\frac{\xi_p}{g_1} \right) - \frac{4}{3} a_1^3 \ln \left(\frac{\xi_p^2 - a_1^2}{2g_1} \right) \quad (58)$$

where $g_1 = \mu + 1$.

The limiting depth can be evaluated from

$$\xi_{p\infty}/a_1 = \frac{(\mu+a_1)^M + 1}{(\mu+a_1)^M - 1} \quad (59)$$

where $M = \frac{\beta}{1+\beta} (1+b_1\alpha)$.

In this equation $\xi_{p\infty}$ denotes the depth to the bottom of the thaw interface on the plane of symmetry where $\xi_0 = 0$. Solutions to eq 57 are plotted in Figures A74-A91 where D is the thickness of the phase change beneath the center of the pipe.

The heat flow rate per unit length of pipe to the surface is given, at any time, by

$$q_p = \frac{2\pi k_1 b_1 (T_p - T_1)}{1 + b_1 \alpha - t_0} \quad (60)$$

where

$$t_0 = b_1 \ln \left(\frac{\xi_p + a_1}{\xi_p - a_1} \right).$$

For hot oil pipes buried in permafrost, the sensible heat is considerably larger than the latent heat. Therefore the Stefan number is quite large and, since the quasi-steady method is based on systems where the Stefan number is near zero, these cases are a severe test of the quasi-steady equations. In order to account for the sensible heat, an effective latent heat parameter can be used, defined as

$$L_e/L = 1 + C_{21} k_{12} \beta S_1 + S_T/2. \quad (61)$$

CONCLUSIONS

The problem of conduction heat transfer with phase change has been solved approximately using the quasi-steady method. The solutions for the buried pipe have been compared to numerical solutions and the quasi-steady results were found to differ by no more than $\pm 20\%$ for most cases (Lunardini 1981d). The pipe solutions also agreed very well with a heat balance integral solution at infinite burial depth (Lunardini 1980). Since these comparisons were for Stefan numbers greater than 1.6, it can be expected that the accuracy in general will be better than $\pm 20\%$ because the quasi-steady method improves as the Stefan number decreases.

The method of calculating conduction heat transfer with phase change presented in this report has been shown to give more reliable results than the widely used graphs of Porkhayev (1970).

The quasi-steady method is extremely useful because it can be applied quite easily to a number of practical cases, and the results can be presented in a compact form as shown by the graphs. These graphs are felt to be acceptable for engineering estimates if accuracies on the order of 20% are adequate. For insulated systems, where the phase change is expected to be more limited, the graphs should be even more accurate.

LITERATURE CITED

- Bell, G.E.** (1978) A refinement of the heat balance integral method applied to a melting problem. *International Journal of Heat and Mass Transfer*, vol. 21, p. 1357-1362.
- Carslaw, H.S. and Jaeger, J.C.** (1959) *Conduction of Heat in Solids*. 2nd ed., Oxford: Clarendon Press.
- Goodman, T.R.** (1958) The heat-balance integral and its application to problems involving a change of phase. *American Society of Mechanical Engineers*, vol. 80, p. 335-342.
- Hwang, C.T.** (1977) On quasi-static solutions for buried pipes in permafrost. *Canadian Geotechnical Journal*, vol. 14, p. 180-192.
- Jumikis, A.R.** (1978) Graphs for disturbance temperature distribution in permafrost under heated rectangular structures. *Proceedings, Third International Conference on Permafrost*, vol. 1, p. 589-598, National Research Council of Canada, Ottawa, Canada.
- Lachenbruch, A.H.** (1957a) Three-dimensional heat conduction in permafrost beneath heated buildings. U.S. Geological Survey Bulletin 1052-B, U.S. Government Printing Office, Washington, D.C.

- Lachenbruch, A.H.** (1957b) Thermal effects of the ocean on permafrost. *Bulletin of the Geological Society of America*, vol. 68, p. 1515-1530.
- Lachenbruch, A.H.** (1959) Periodic heat flow in a stratified medium with applications to permafrost problems. U.S. Geological Survey Bulletin 1083-A.
- Lunardini, V.J.** (1980) Phase change around a circular pipe. U.S.A. Cold Regions Research and Engineering Laboratory (CRREL) Report 80-27. AD A094600.
- Lunardini, V.J.** (1981a) *Heat Transfer in Cold Climates*. New York: Van Nostrand Reinhold.
- Lunardini, V.J.** (1981b) Phase change around insulated buried pipes: Quasi-steady method. *Journal of Energy Resources Technology*, vol. 103, no. 3, p. 201-207.
- Lunardini, V.J.** (1981c) Application of the heat balance integral to conduction phase change problems. CRREL Report 81-25.
- Lunardini, V.J.** (1981d) Approximate phase change solutions for insulated buried cylinders. ASME Paper 81-WA/HT-50. Presented at 1981 ASME Winter Annual Meeting, Washington, D.C.
- Lunardini, V.J. and R. Varotta** (1981) Approximate solution to Neumann problem for soil systems. *Journal of Energy Resources Technology*, vol. 103, no. 1, p. 76-81.
- Porkhayev, G.V.** (1963) Temperature fields in foundations. *Permafrost: Proceedings of an International Conference*, National Academy of Sciences, Washington, D.C., pub. 1287, p. 285-291.
- Porkhayev, G.V.** (1970) *Thermal Interaction Between Buildings, Structures, and Perennially Frozen Ground*, Moscow: Nauka Publishing House.
- Seshardri, R. and A.V.G. Krishnayya** (1980) Quasi-steady approach for thermal analysis of insulated structures. *International Journal of Heat and Mass Transfer*, vol. 23, p. 111-121.
- Thornton, D.C.** (1976) Steady state and quasi-static thermal results for bare and insulated pipes in permafrost. *Canadian Geotechnical Journal*, vol. 13, no. 2, p. 161-170.
- Yuen, W.W.** (1980) Application of the heat balance integral to melting problems with initial sub-cooling. *International Journal of Heat and Mass Transfer*, vol. 23, p. 1157-1160.

APPENDIX A. CALCULATED DESIGN GRAPHS.

FIGURE

A1-A12	Phase change beneath center of infinite strip.
A13-A15	Limiting phase change for infinite strip.
A16-A27	Phase change beneath center of rectangle, $n = 1$.
A28-A39	Phase change beneath center of rectangle, $n = 2$.
A40-A51	Phase change beneath center of rectangle, $n = 3$.
A52-A60	Limiting phase change for rectangles.
A61-A72	Phase change beneath center of circular storage tank.
A73	Limiting phase change for circular tank.
A74-A91	Phase change beneath buried pipe.

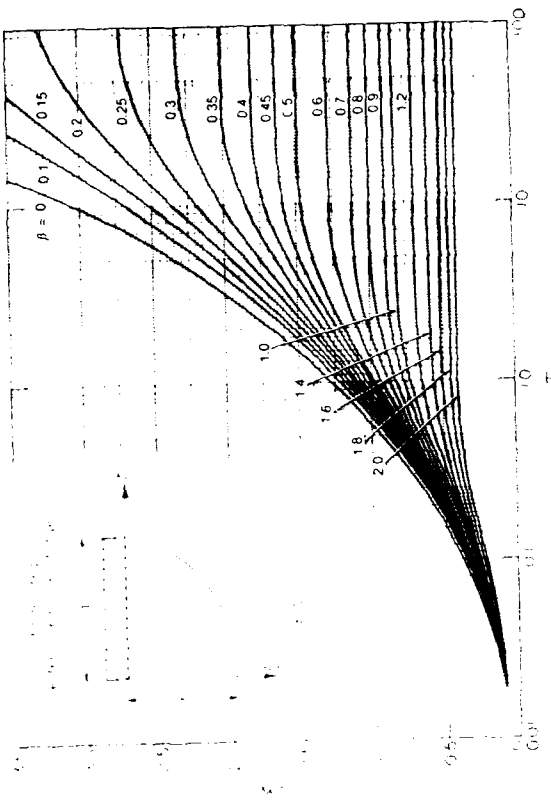

Figure A1.

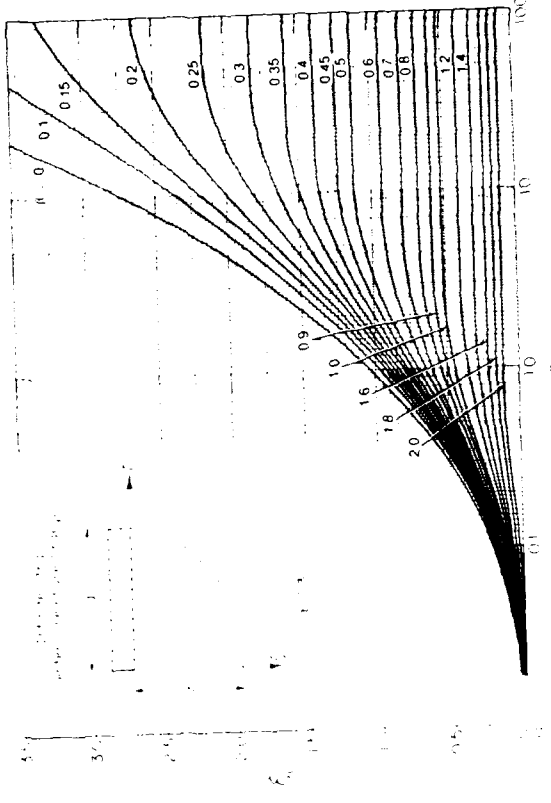

Figure A2.

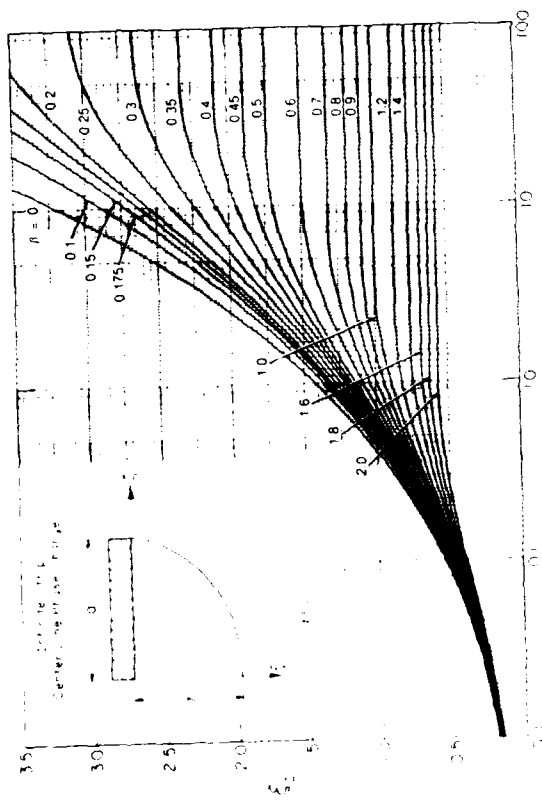

Figure A3.

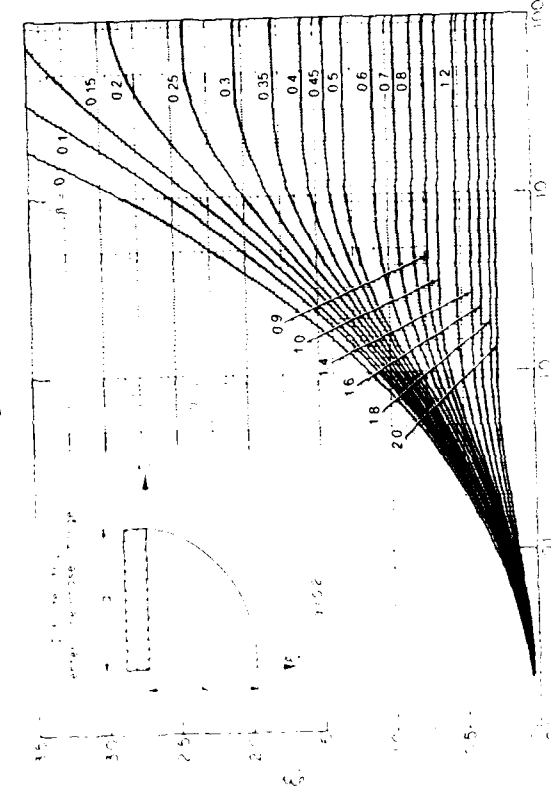

Figure A4.

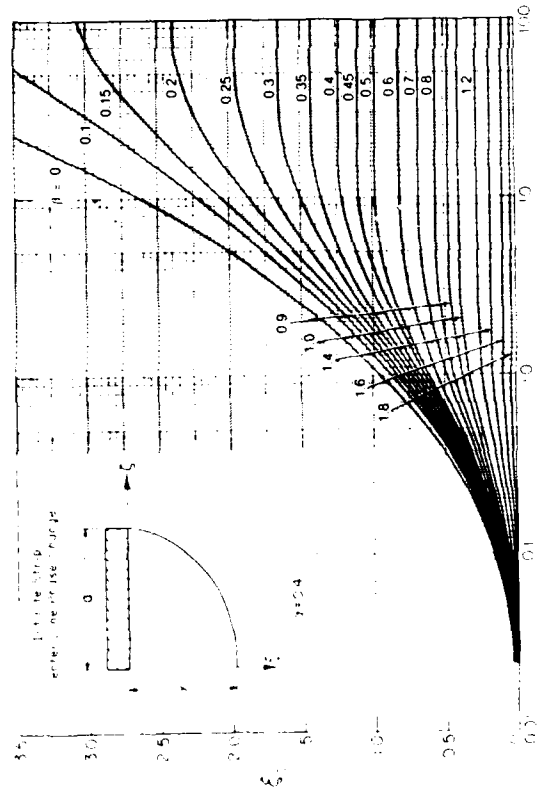

Figure A5

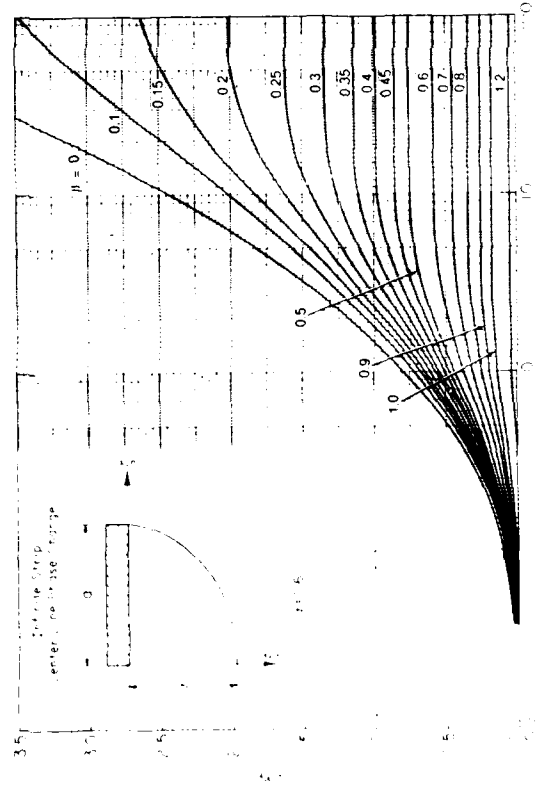

Figure A7

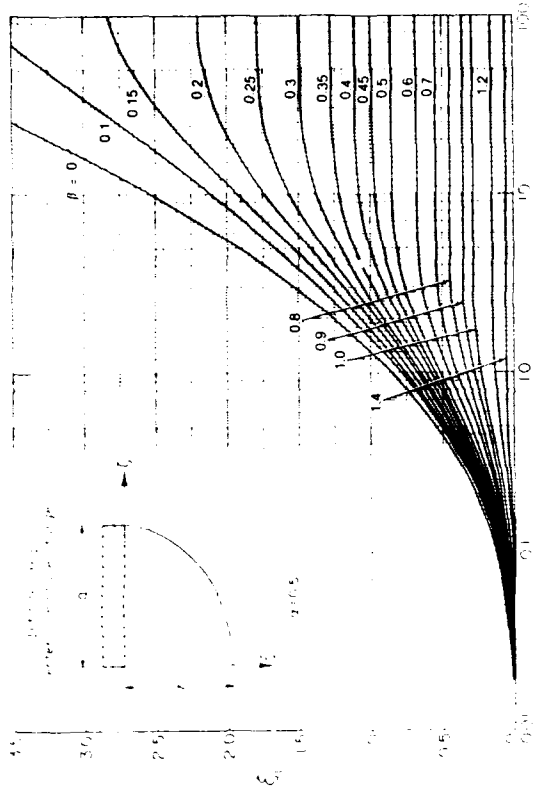

Figure A6

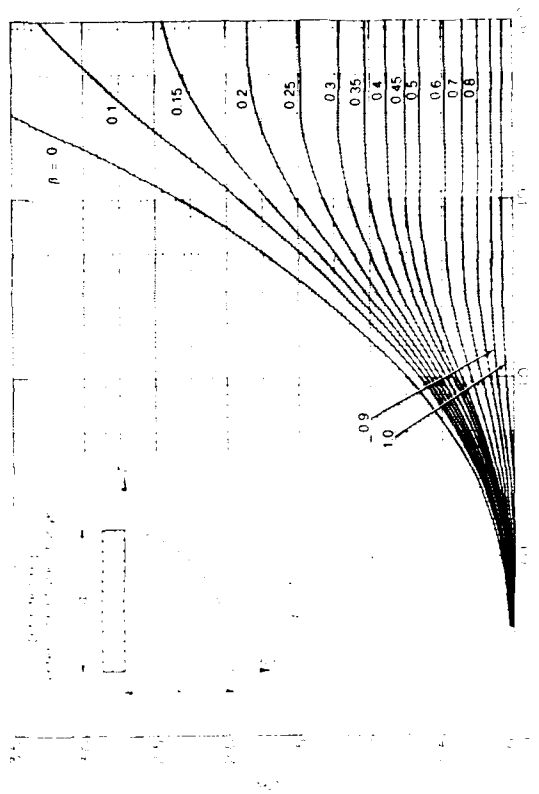

Figure A8

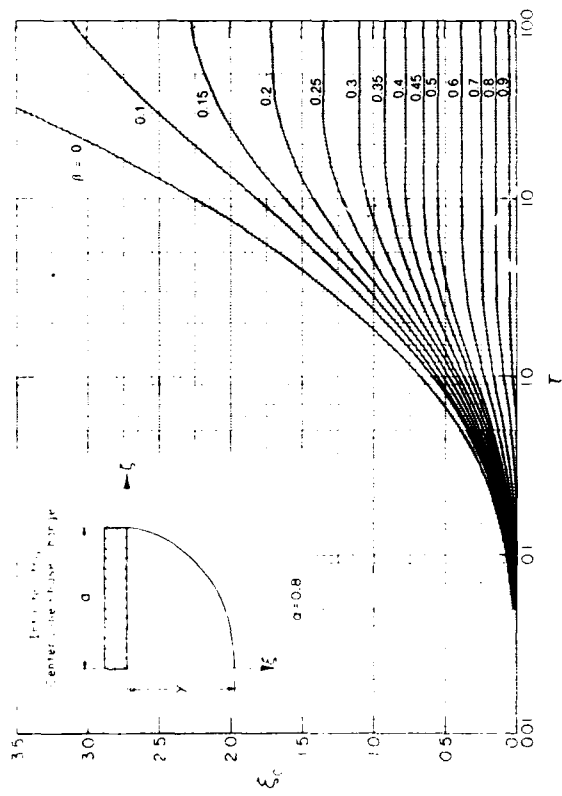

Figure A9.

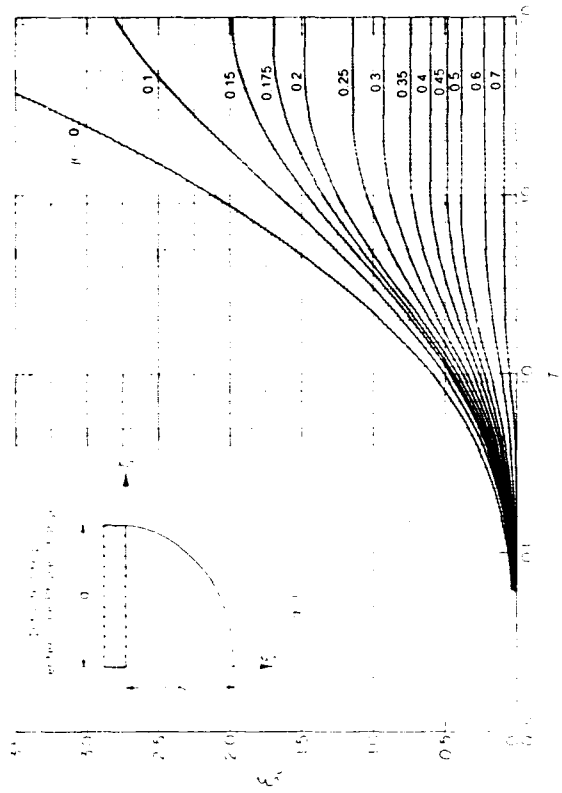

Figure A10.

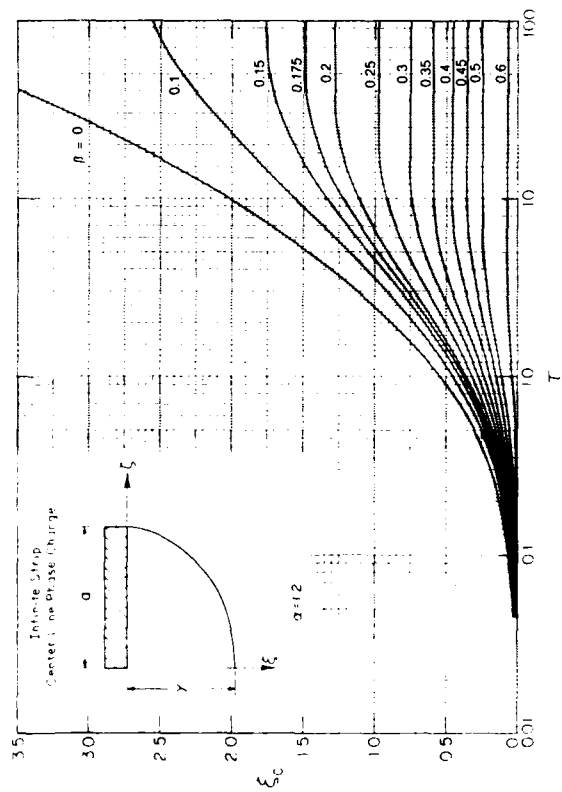

Figure A11.

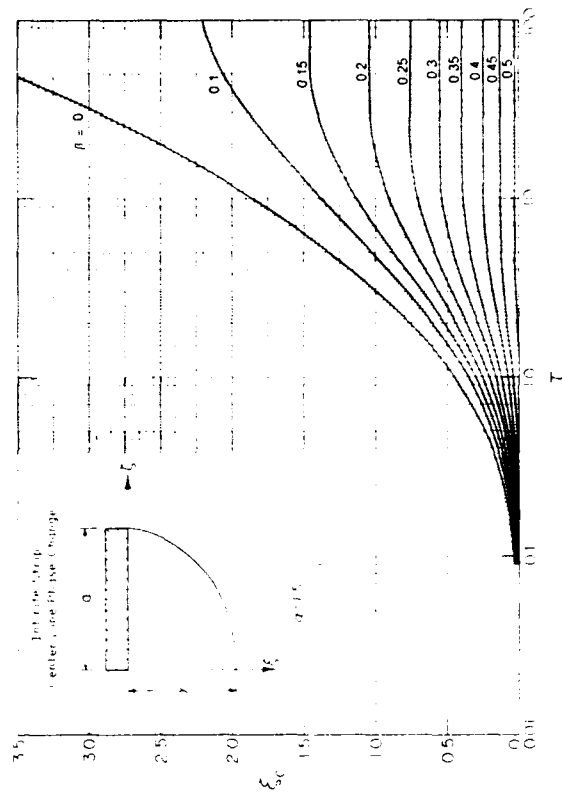

Figure A12.

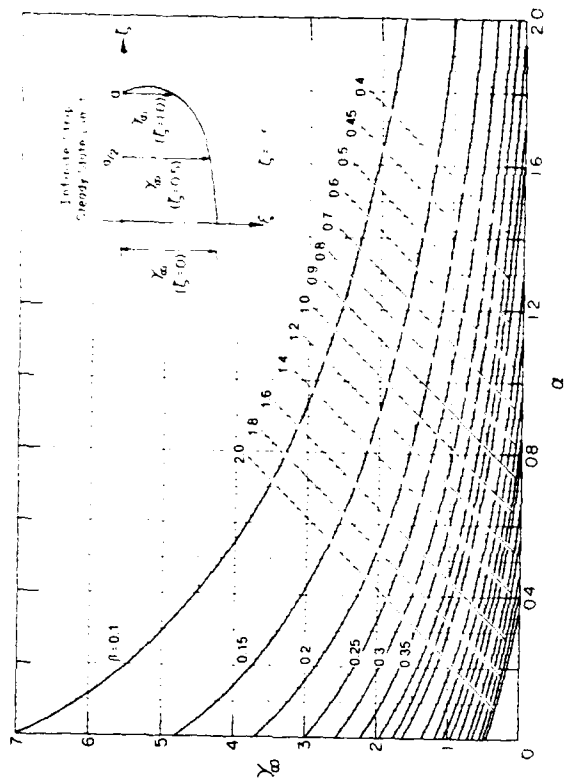

Figure A14.

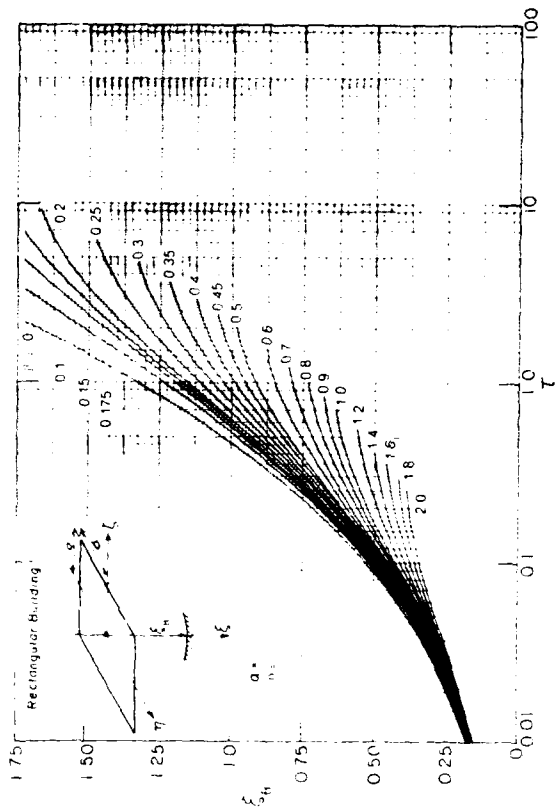

Figure A16.

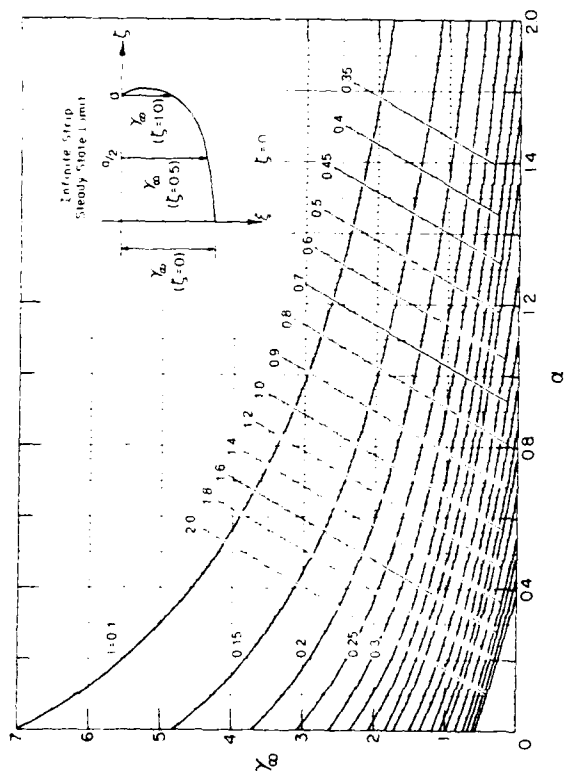

Figure A13.

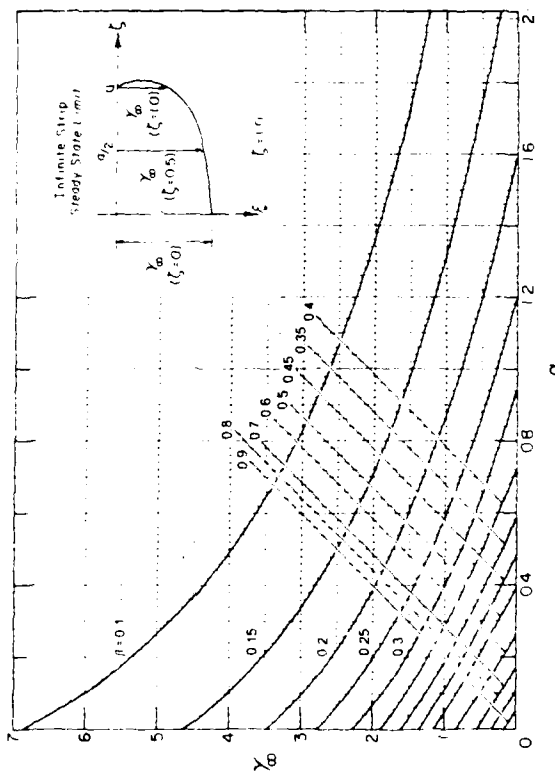

Figure A15.

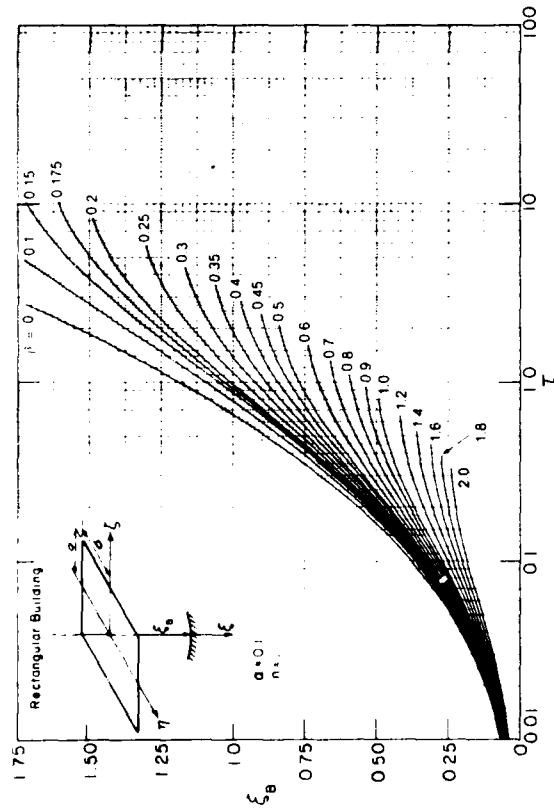

Figure A17.

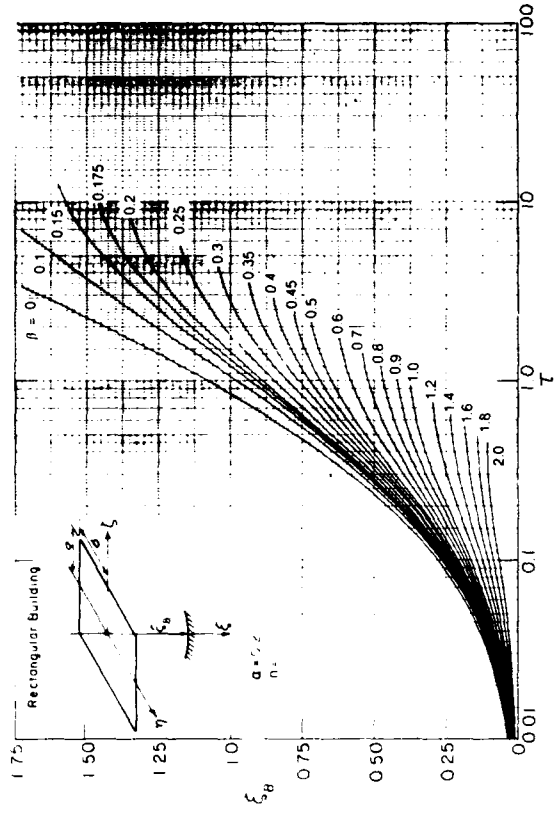

Figure A18.

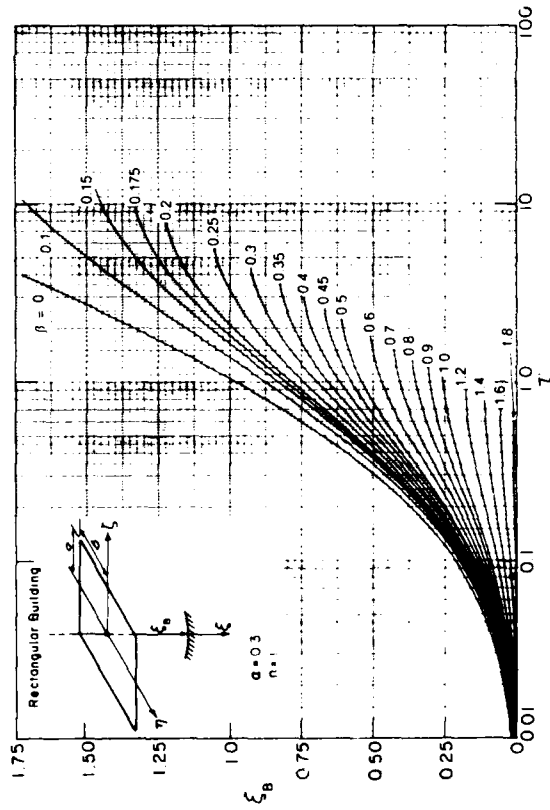

Figure A19.

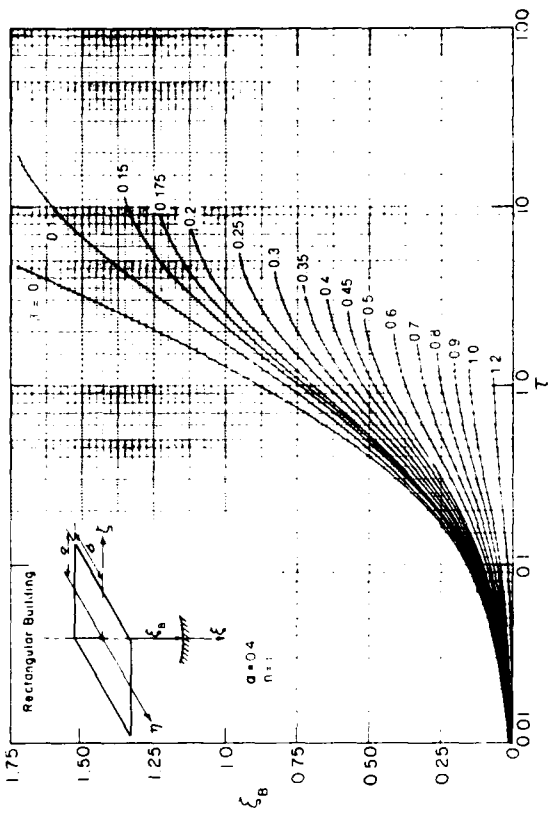

Figure A20.

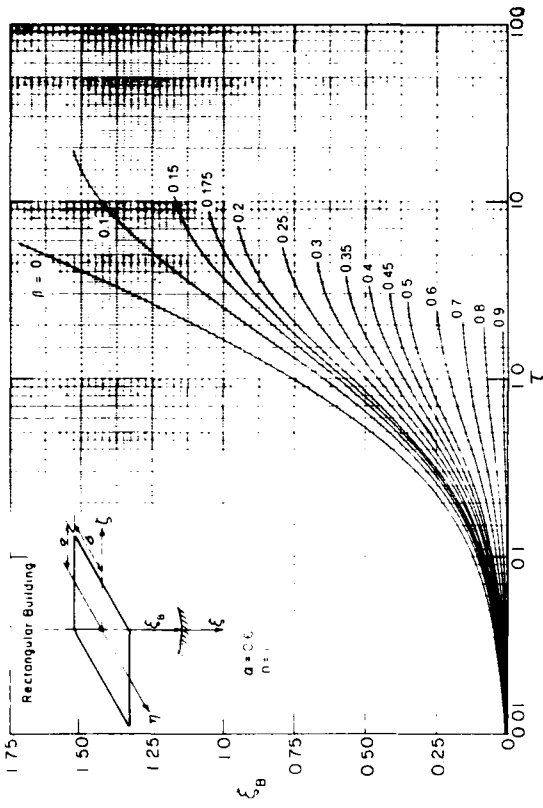

Figure A22.

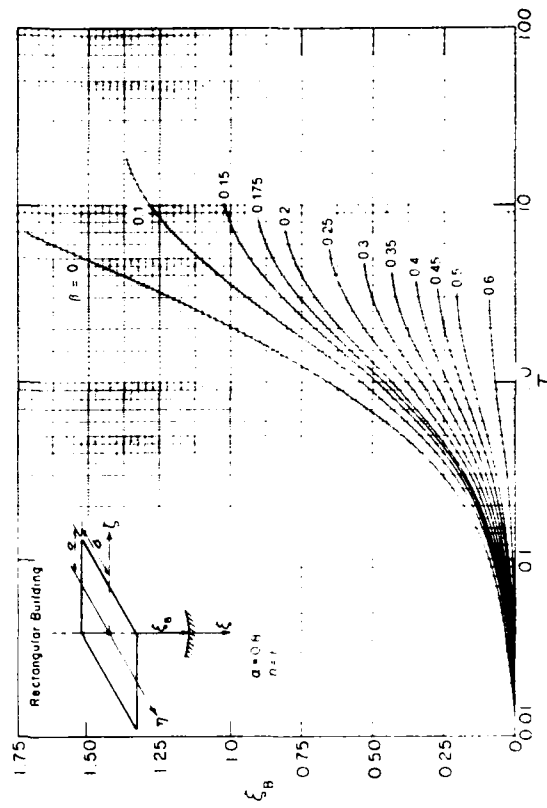

Figure A24.

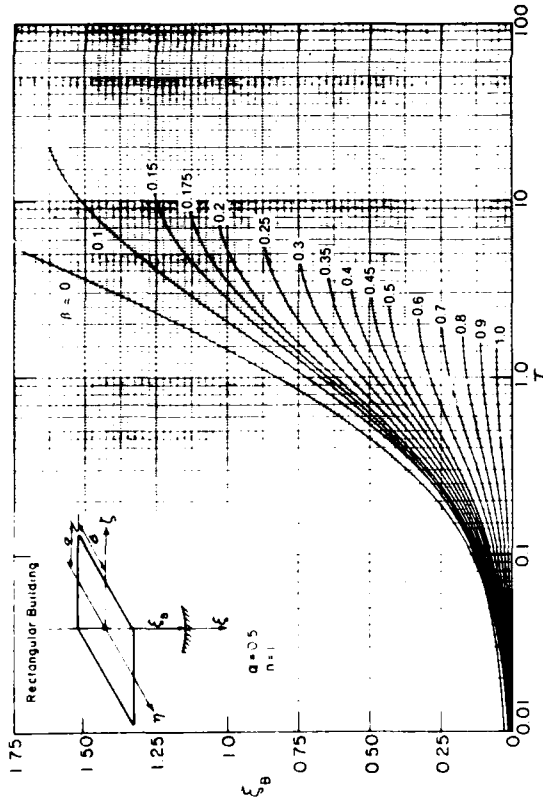

Figure A21.

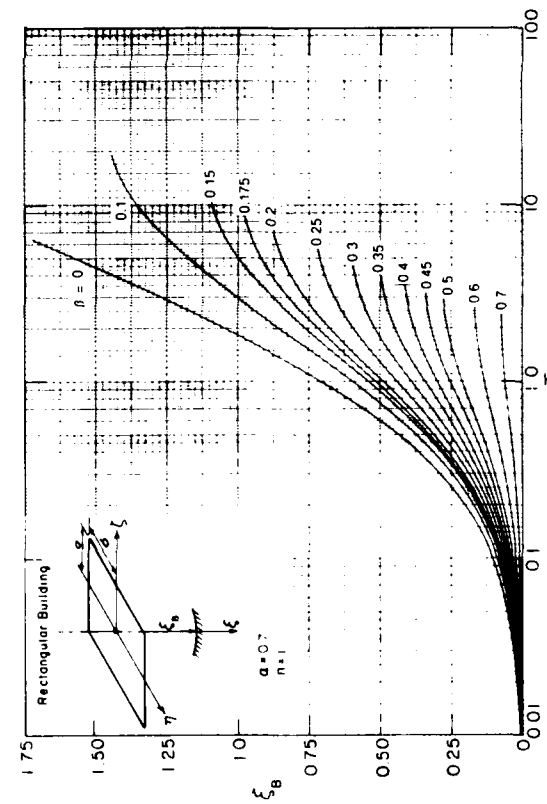

Figure A23.

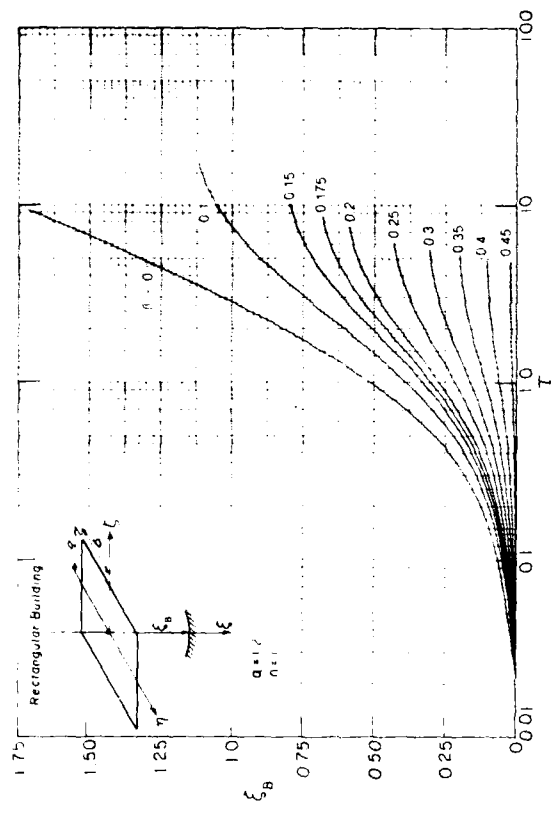

Figure A25.

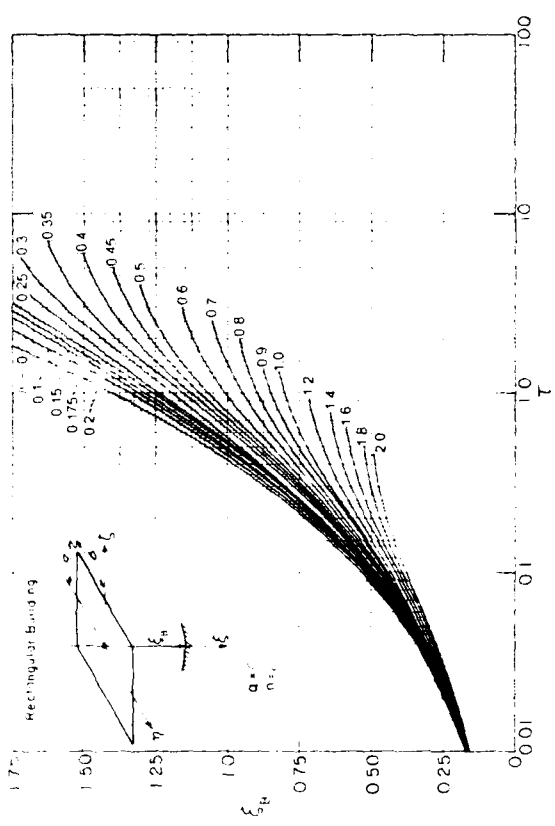

Figure A26.

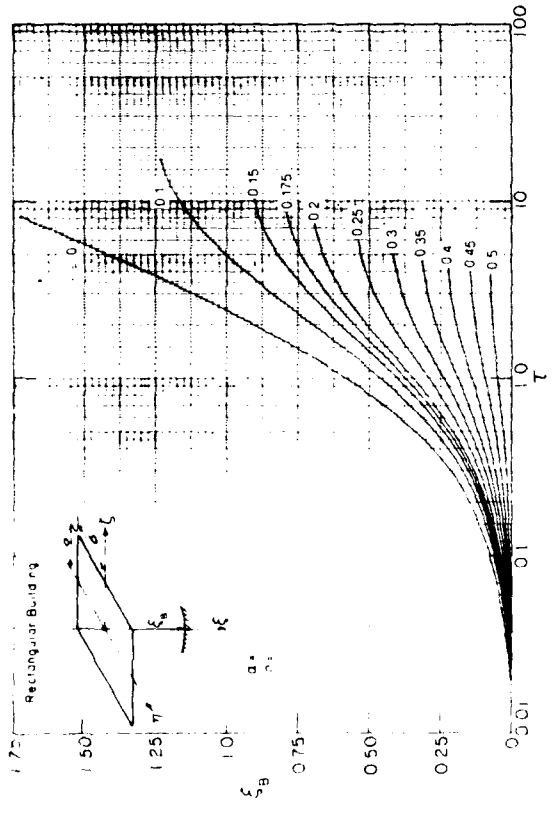

Figure A27.

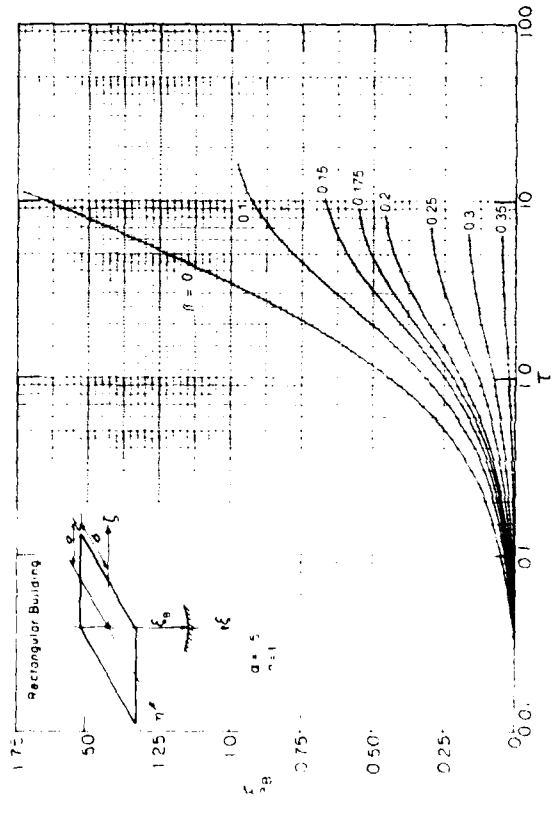

Figure A28.

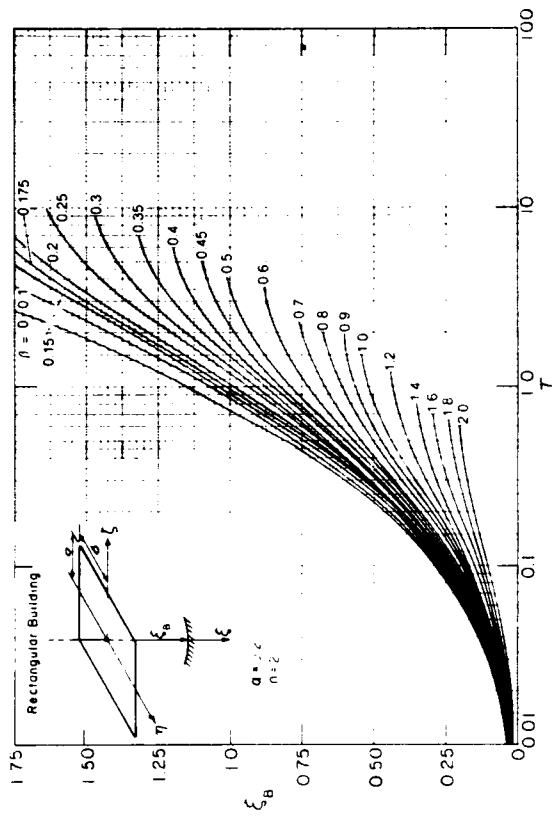

Figure A30.

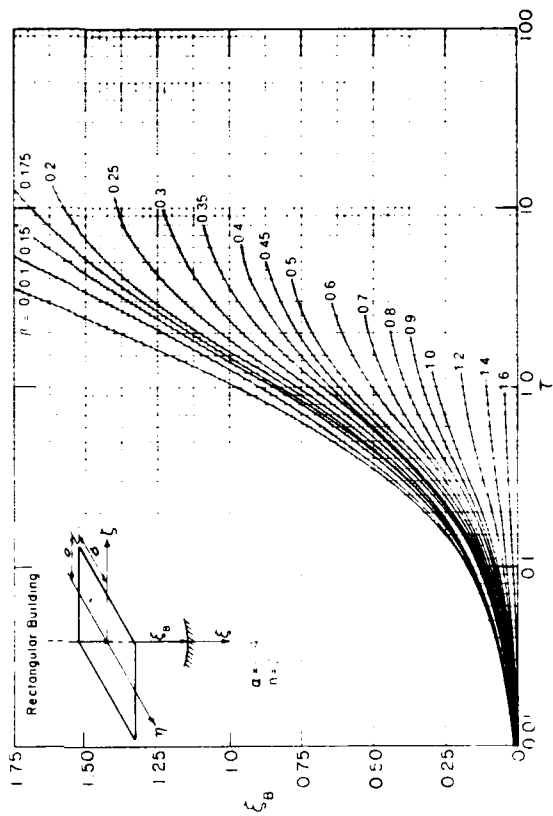

Figure A32.

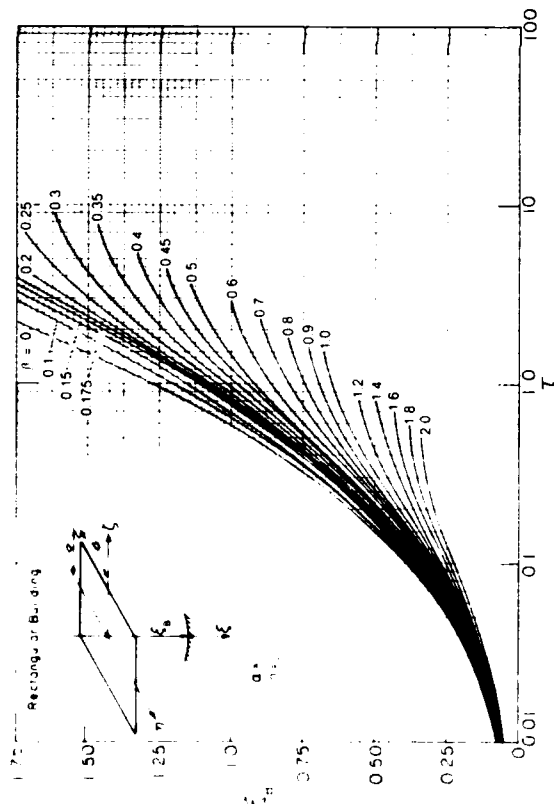

Figure A29.

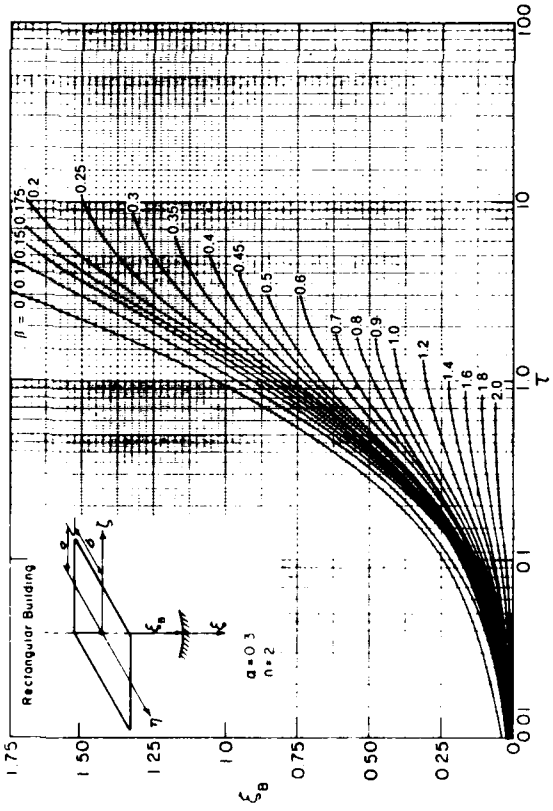

Figure A31.

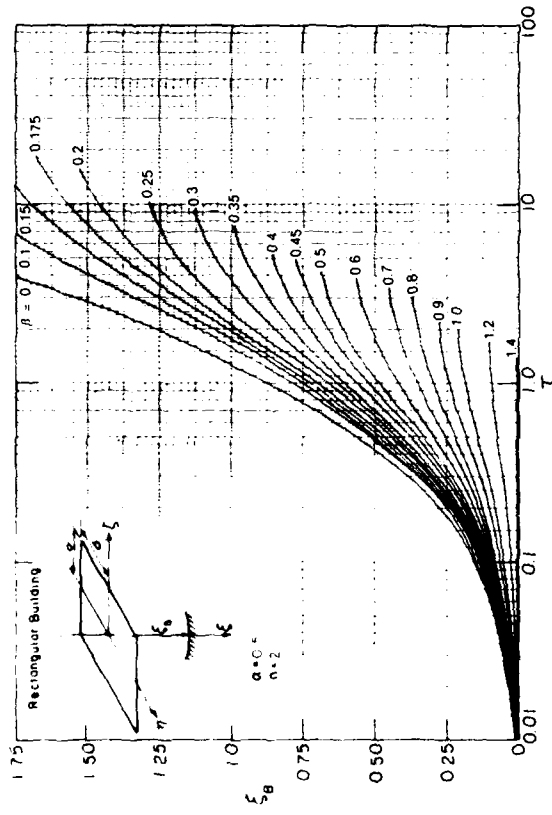

Figure A33.

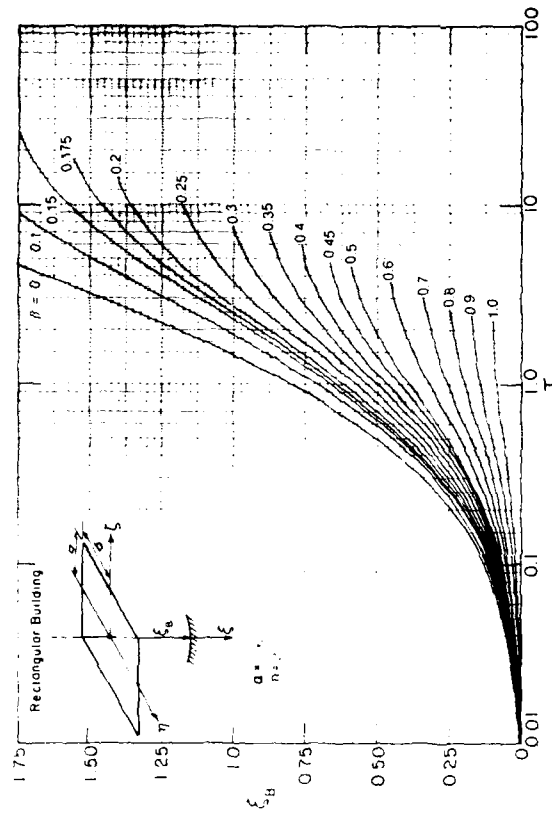

Figure A34.

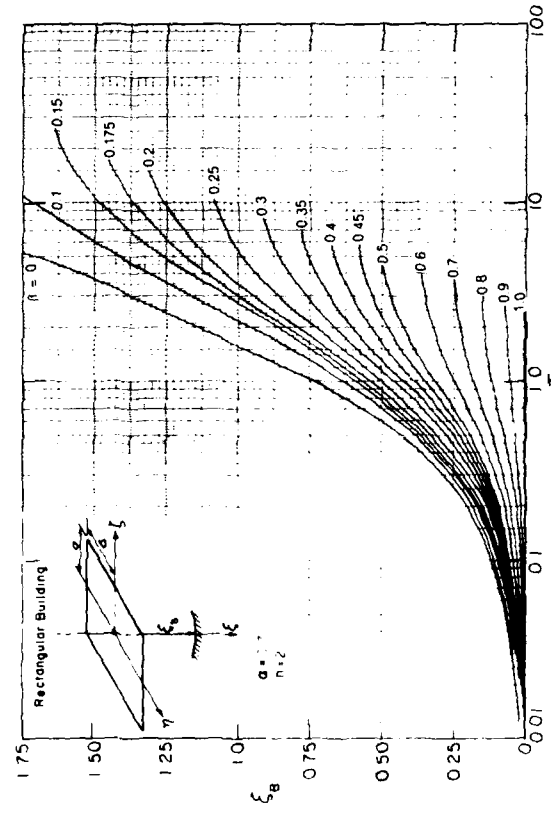

Figure A35.

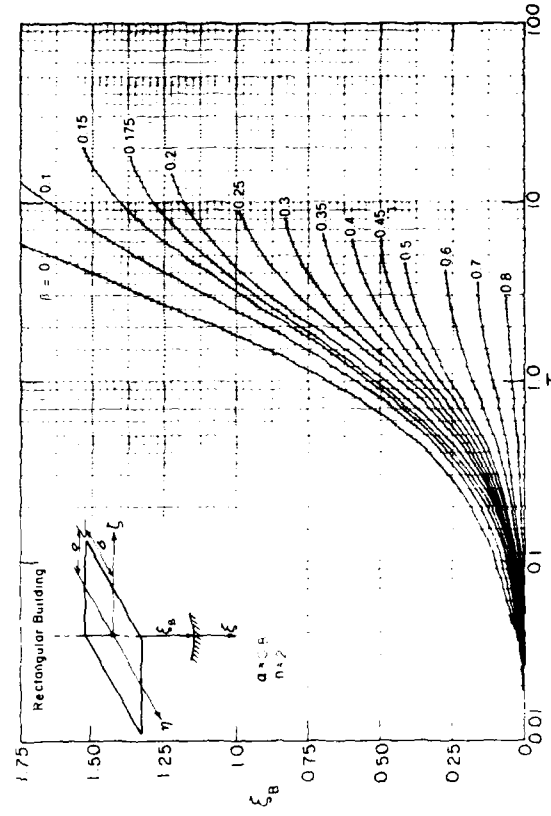

Figure A36.

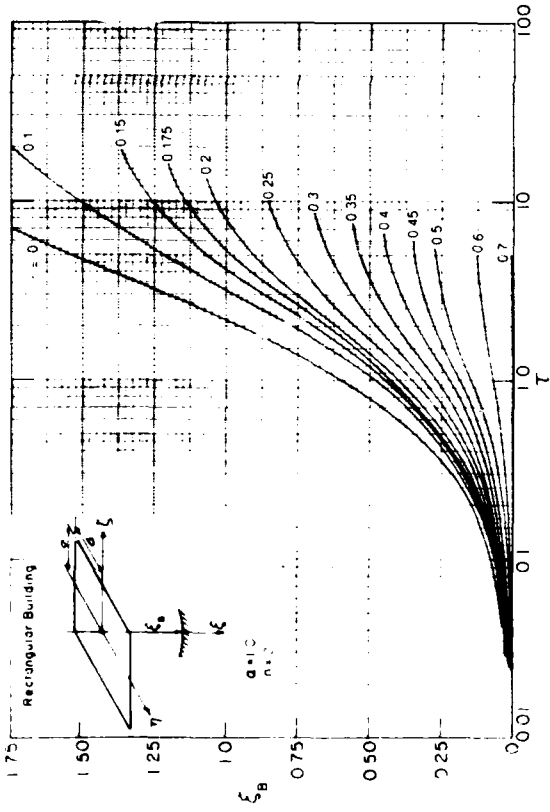

Figure A37.

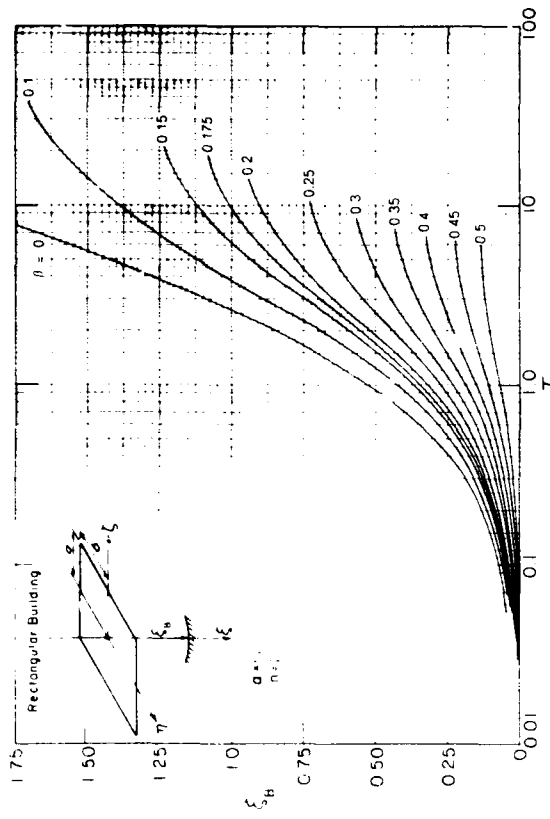

Figure A38.

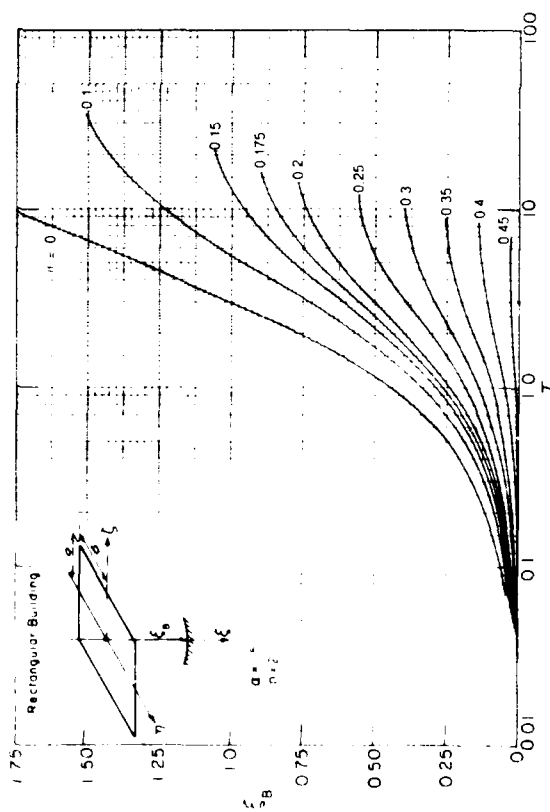

Figure A39.

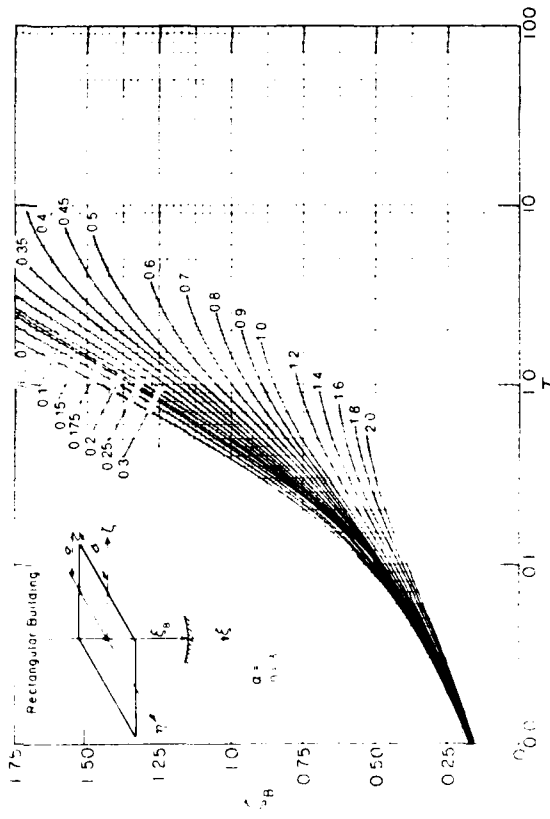

Figure A40.

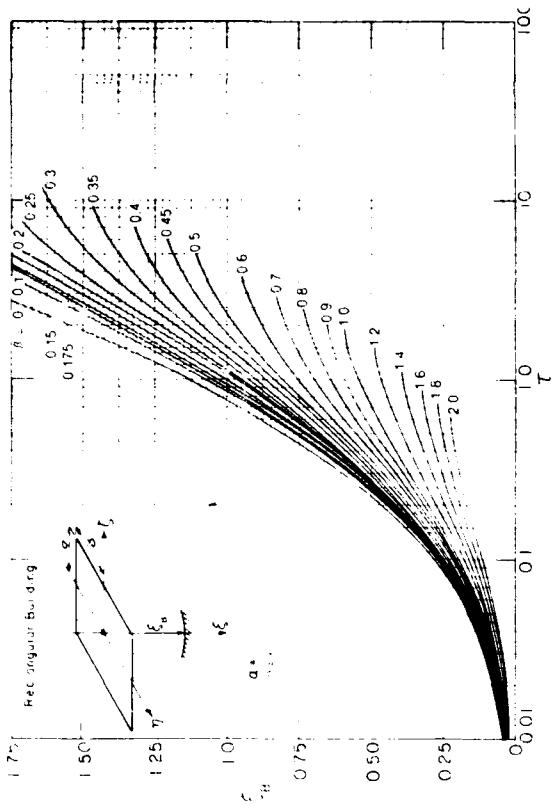

Figure A42.

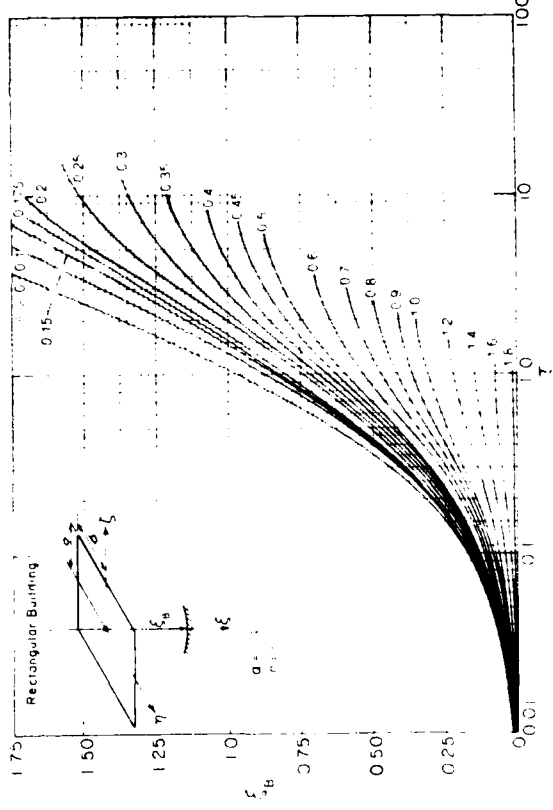

Figure A44.

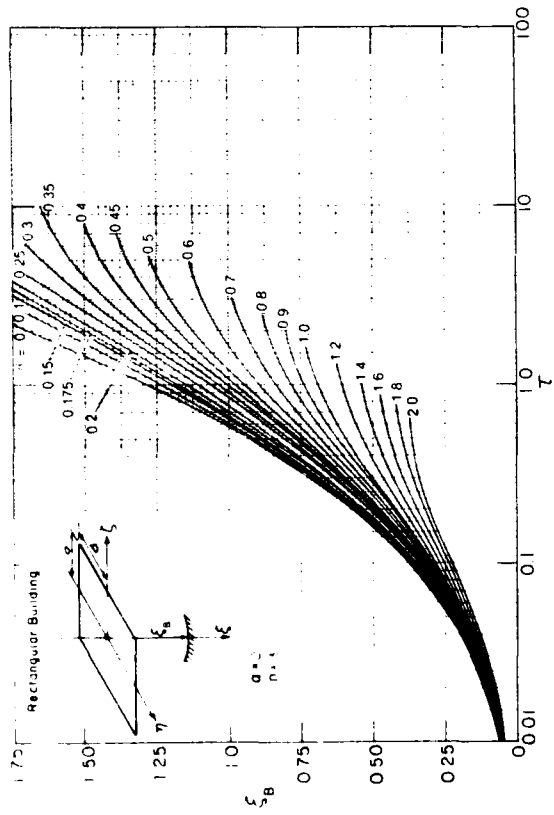

Figure A41.

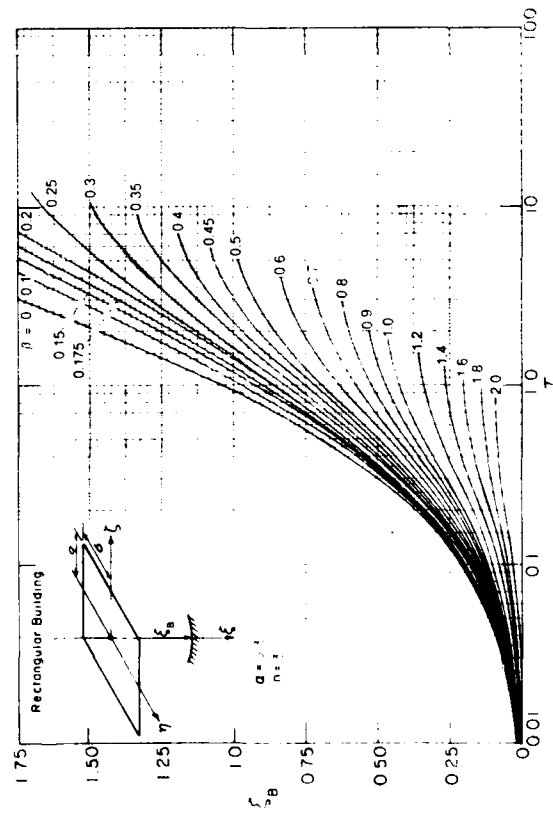

Figure A43.

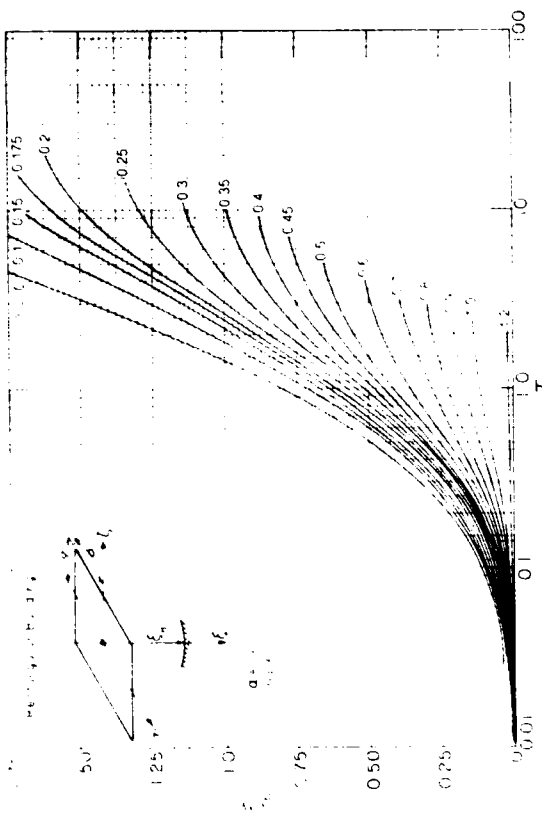

Figure A46.

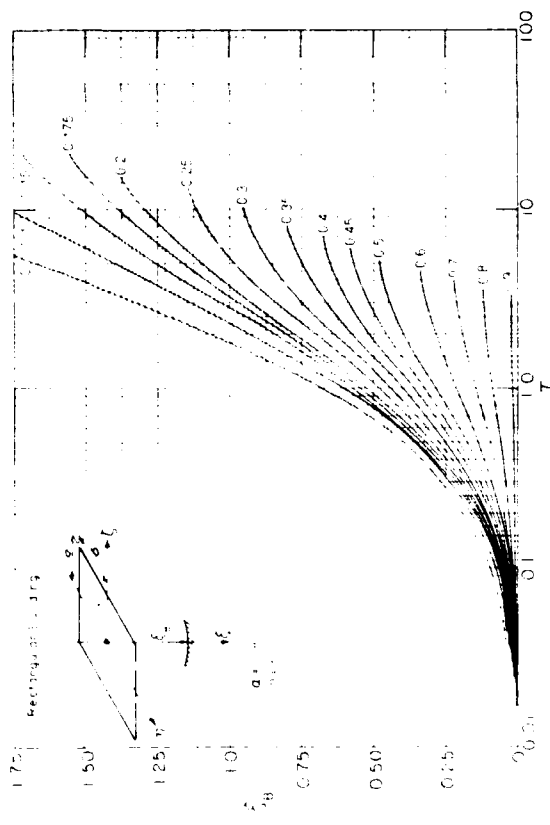

Figure A48.

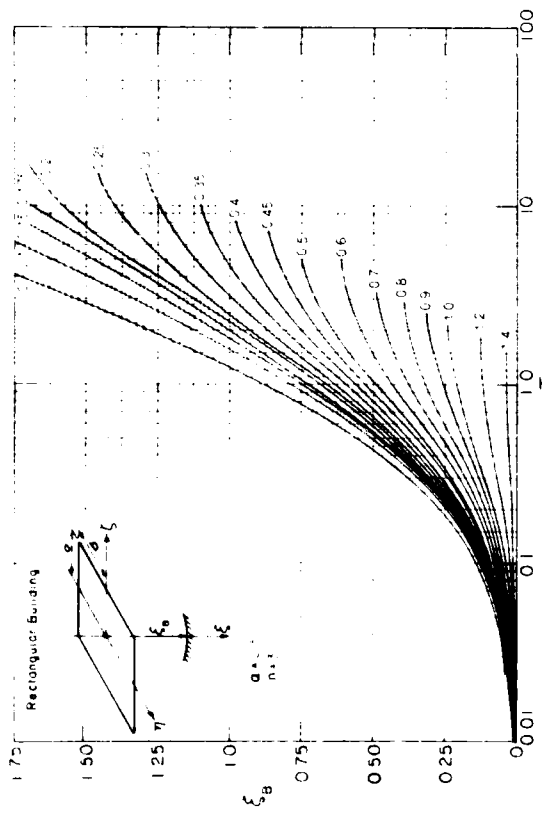

Figure A45.

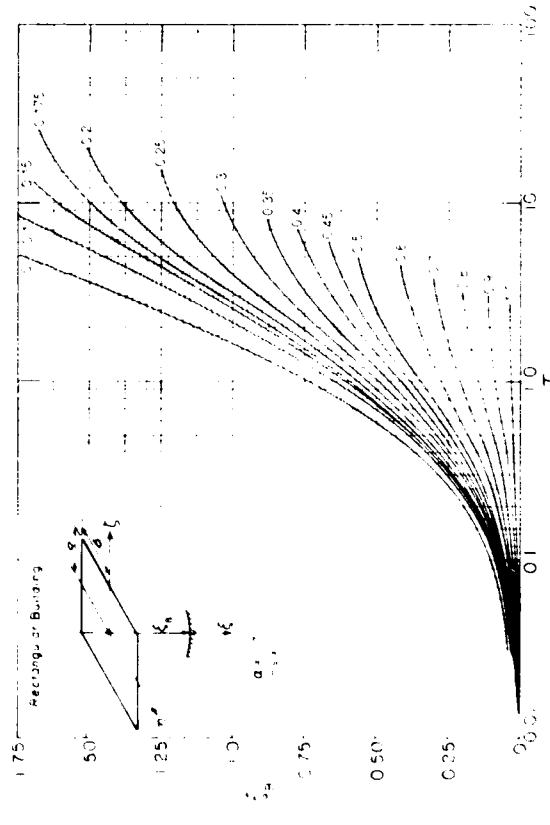

Figure A47.

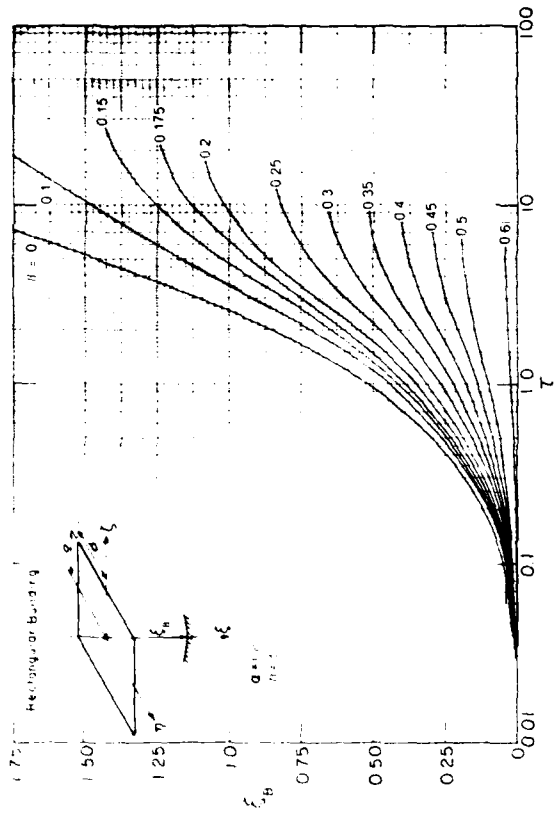

Figure A49.

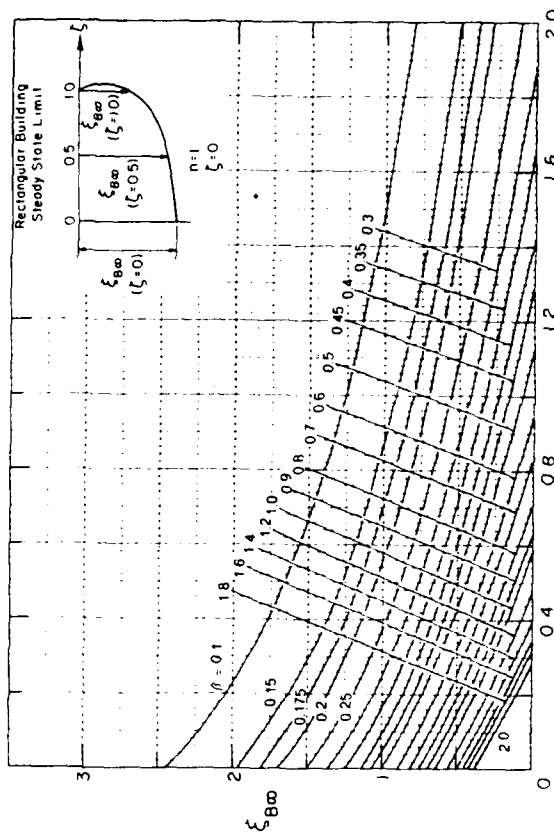

Figure A50.

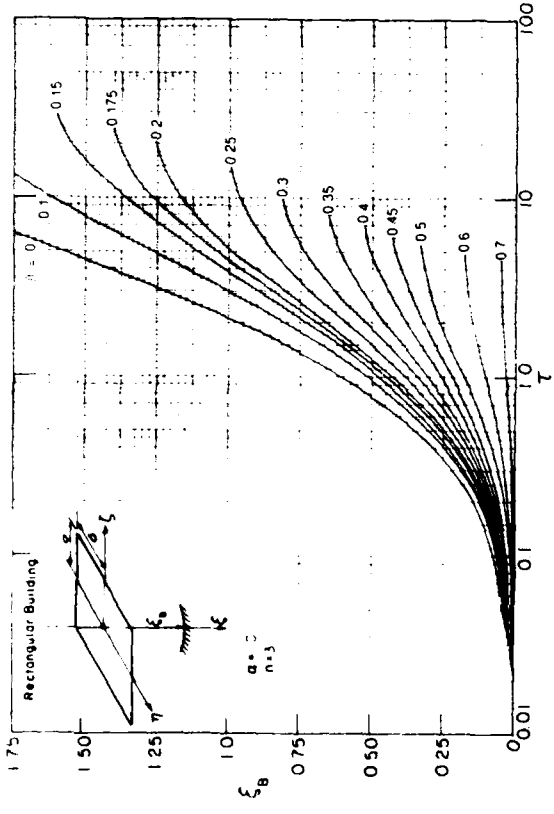

Figure A51.

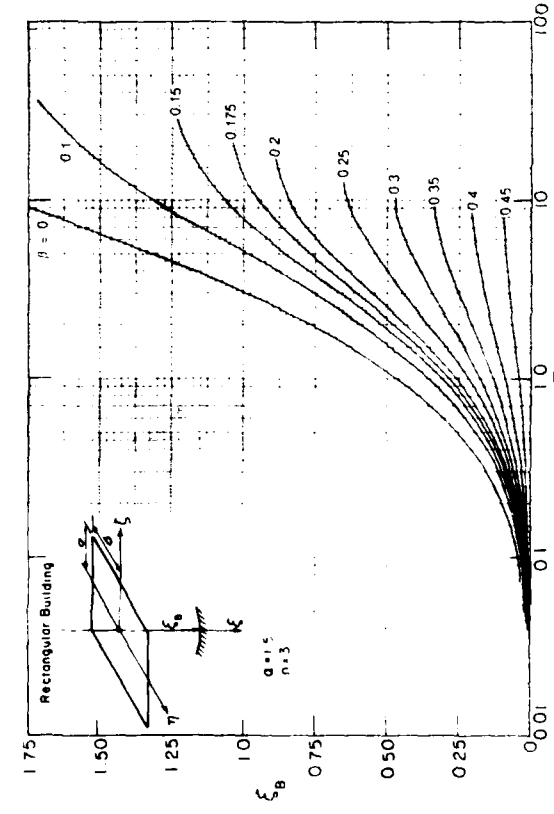

Figure A52.

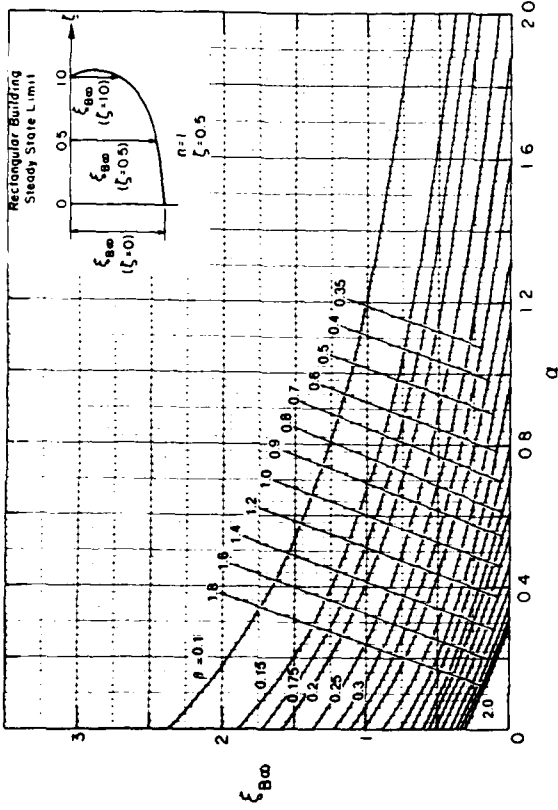

Figure A53.

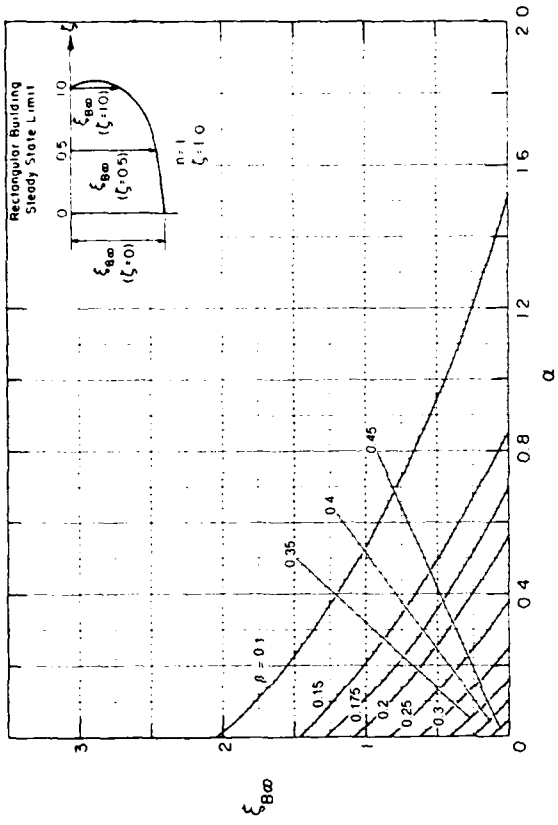

Figure A54.

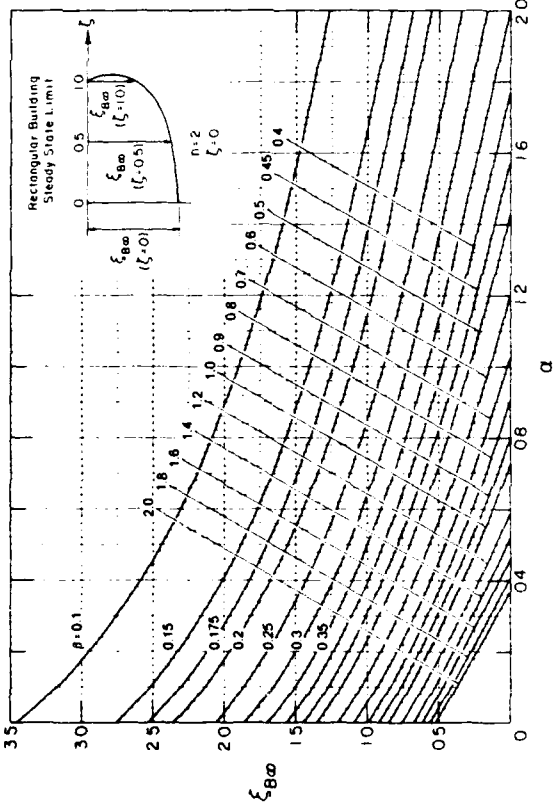

Figure A55.

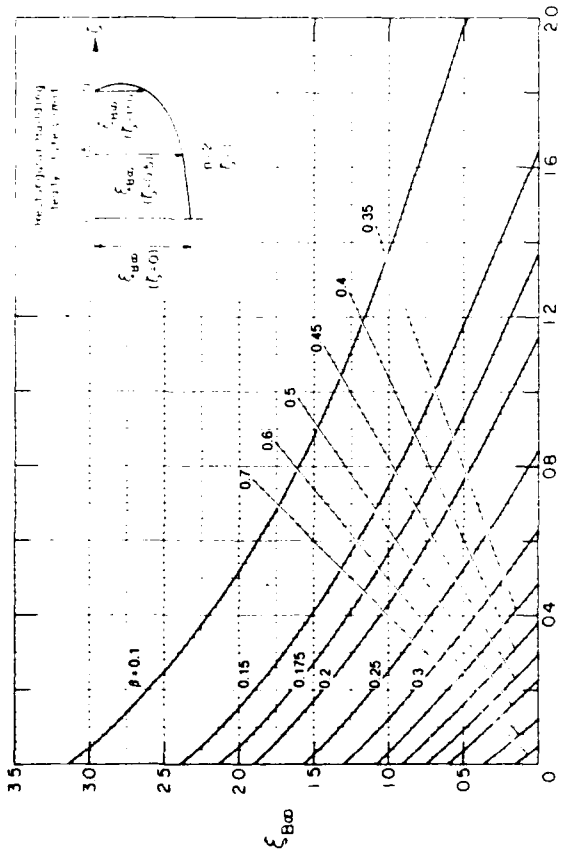

Figure A57.

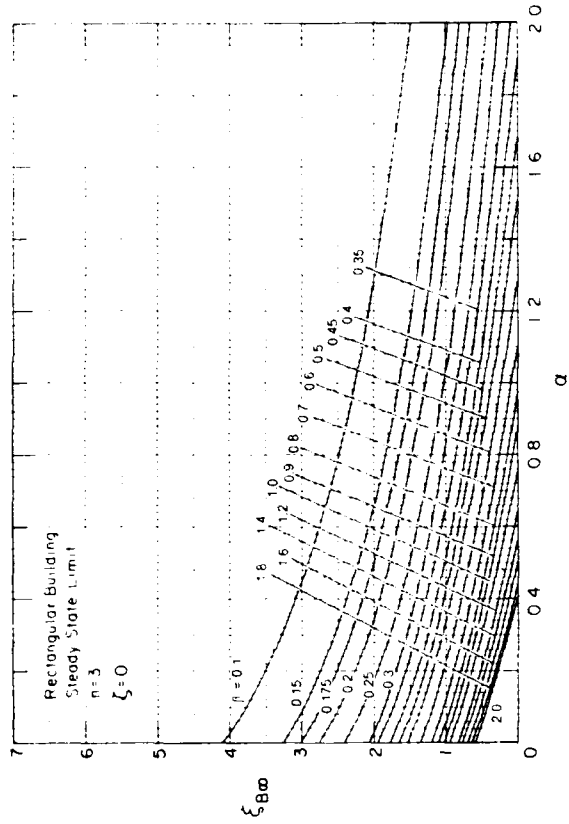

Figure A58.

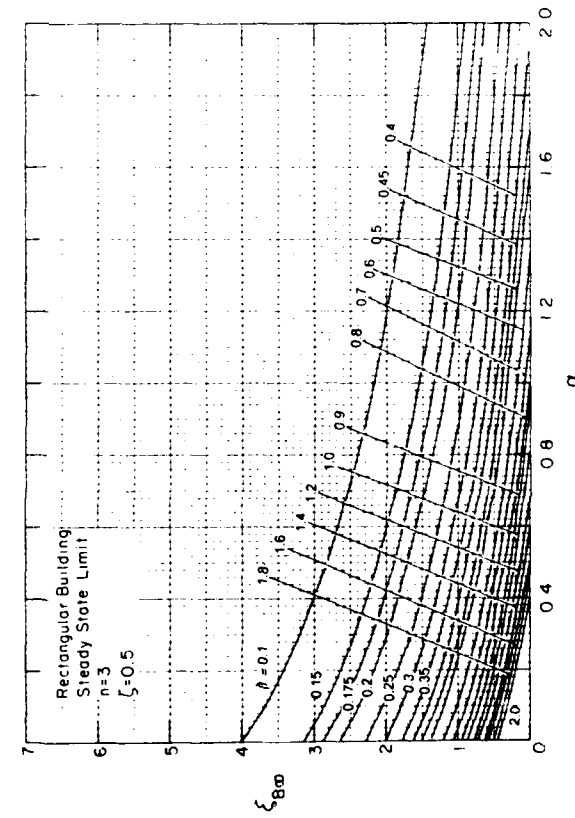

Figure A59.

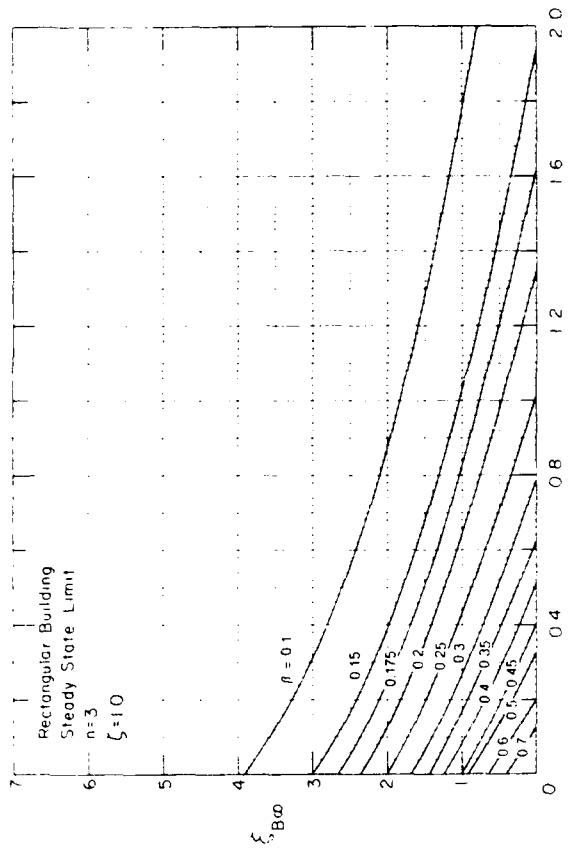

Figure A60.

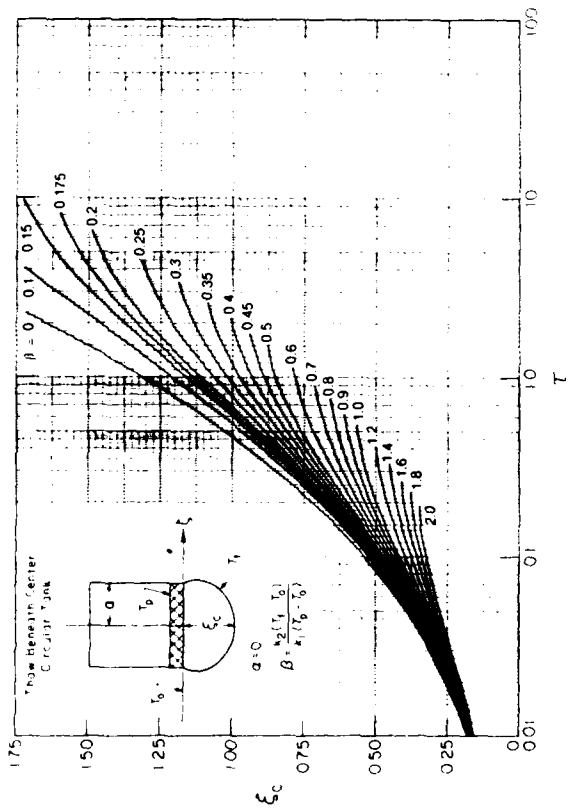

Figure A61.

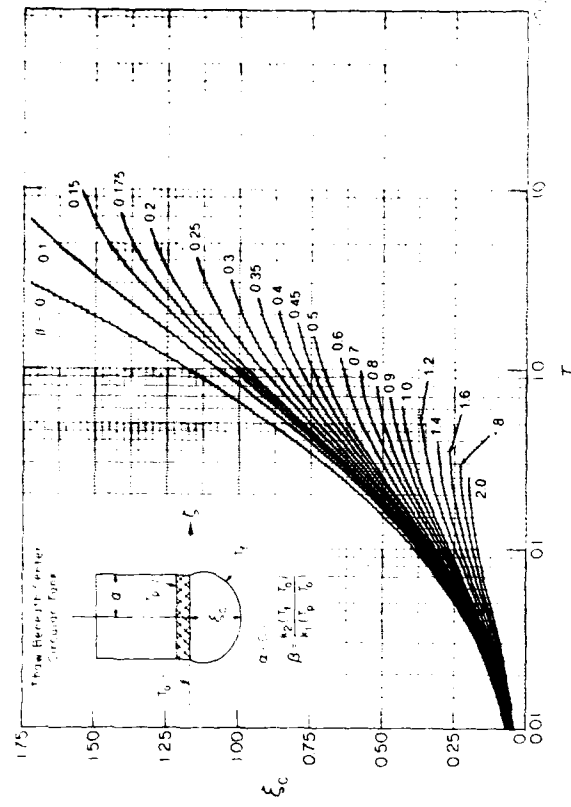

Figure A62.

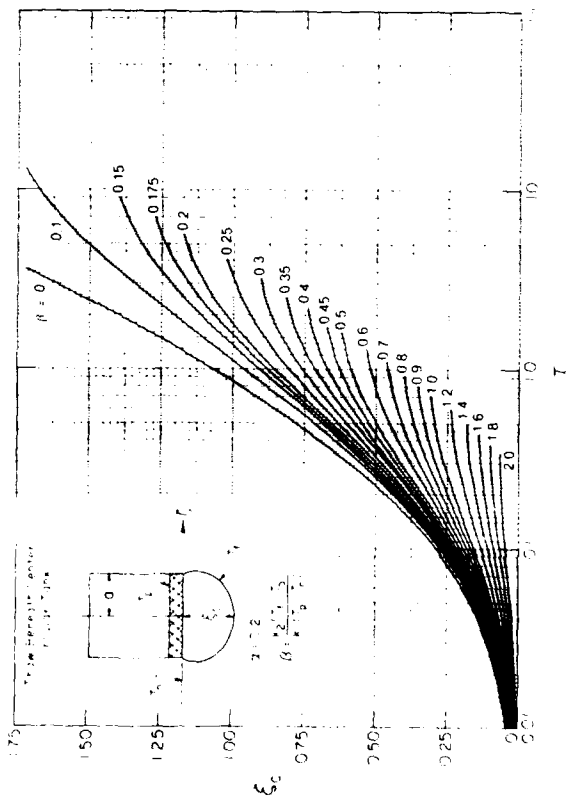

Figure A63.

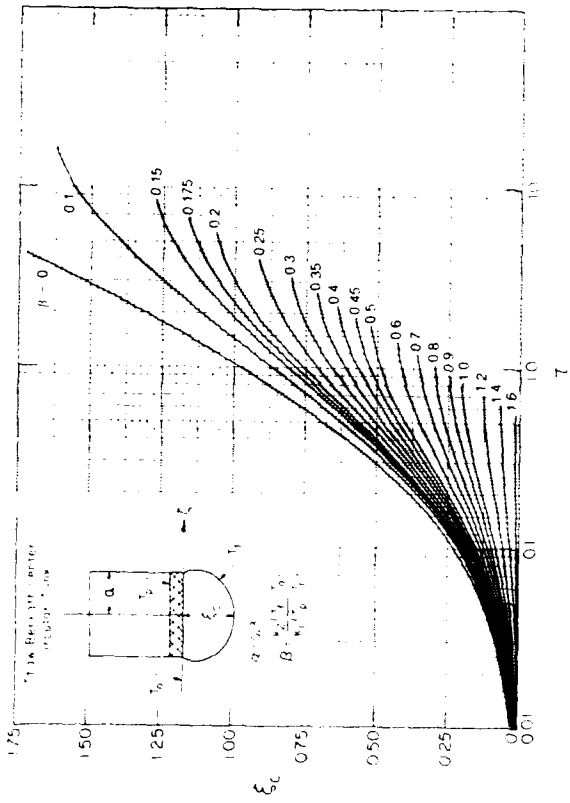

Figure A64.

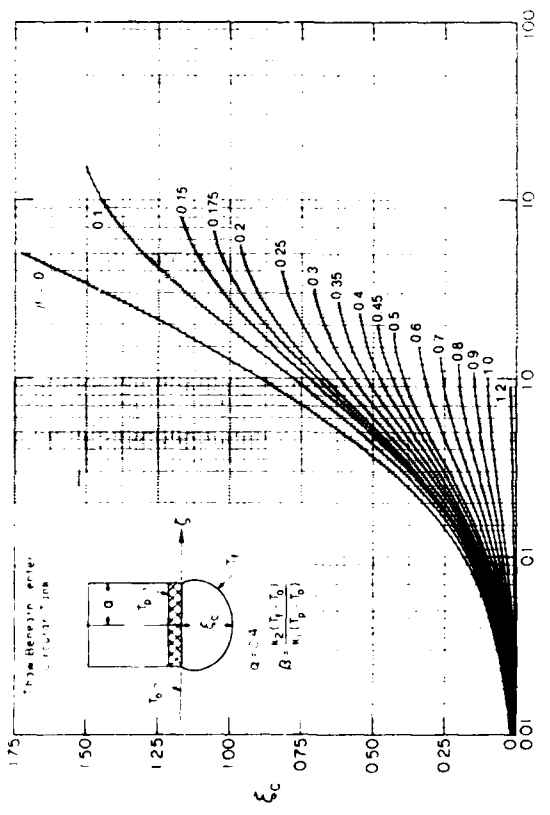

Figure A65.

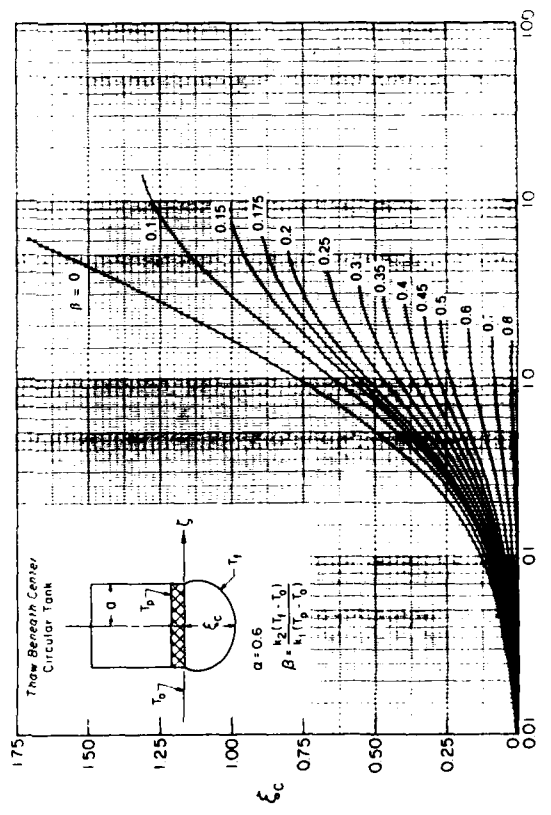

Figure A67.

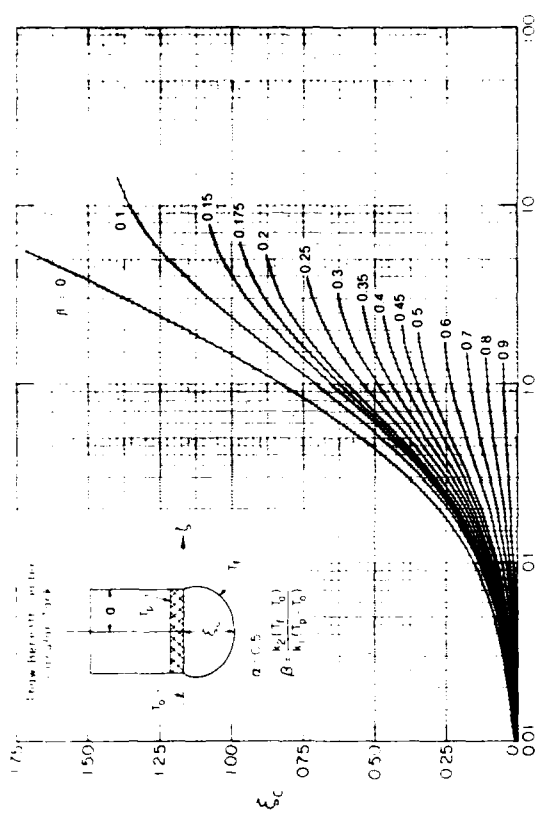

Figure A66.

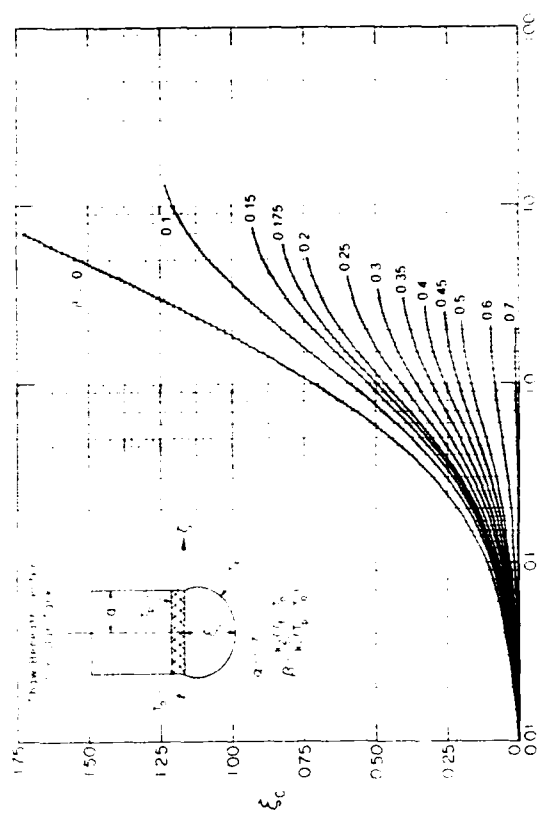

Figure A68.

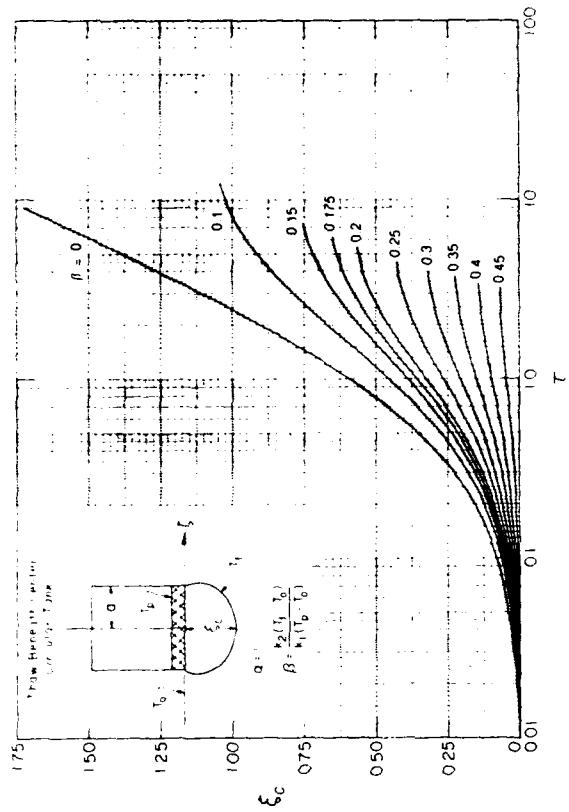

Figure A70.

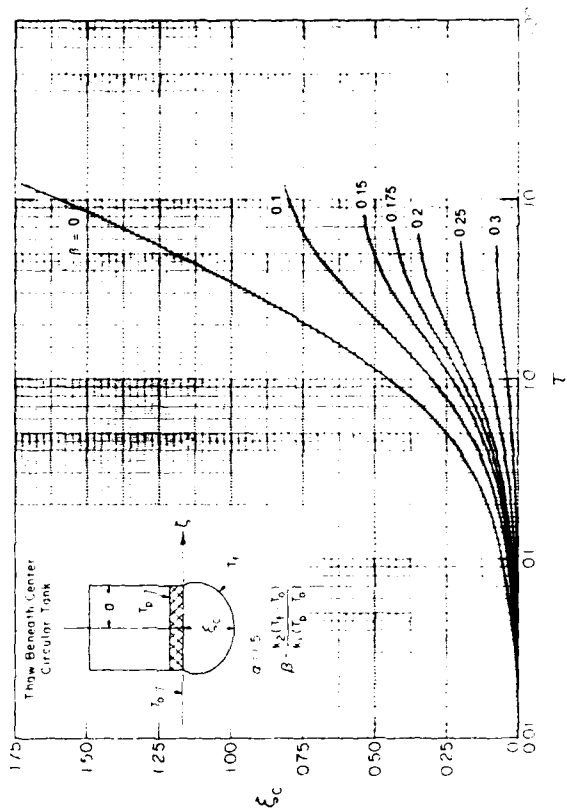

Figure A72.

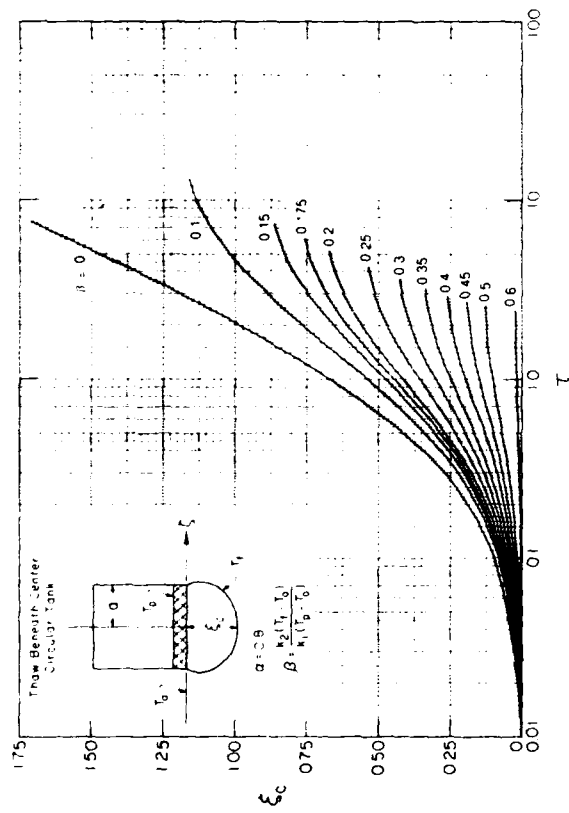

Figure A69.

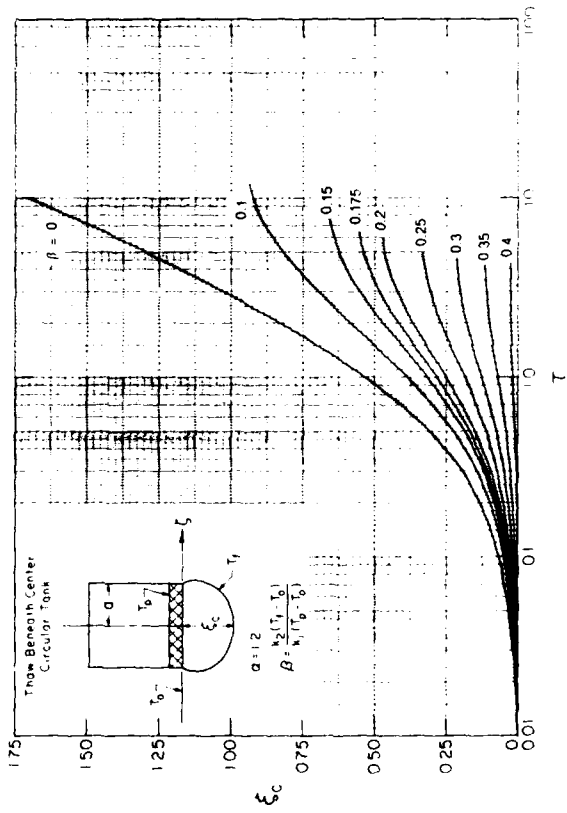

Figure A71.

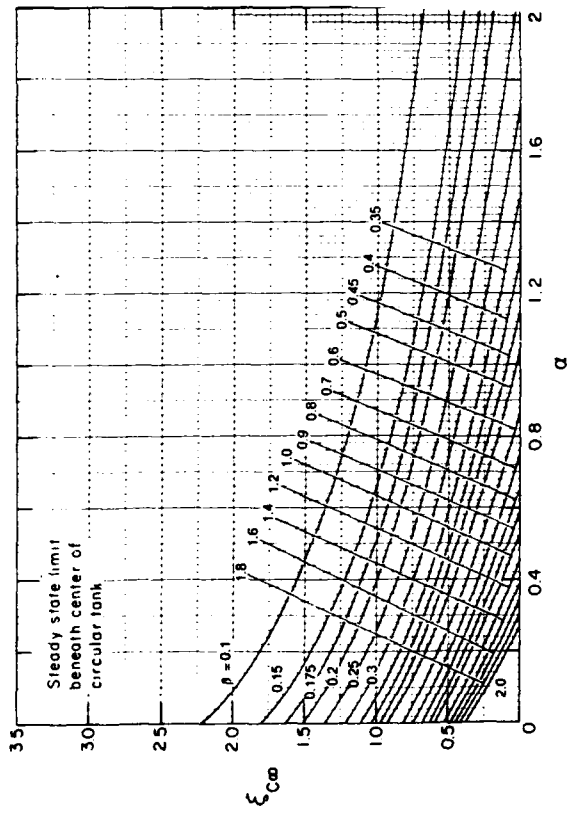

Figure A73.

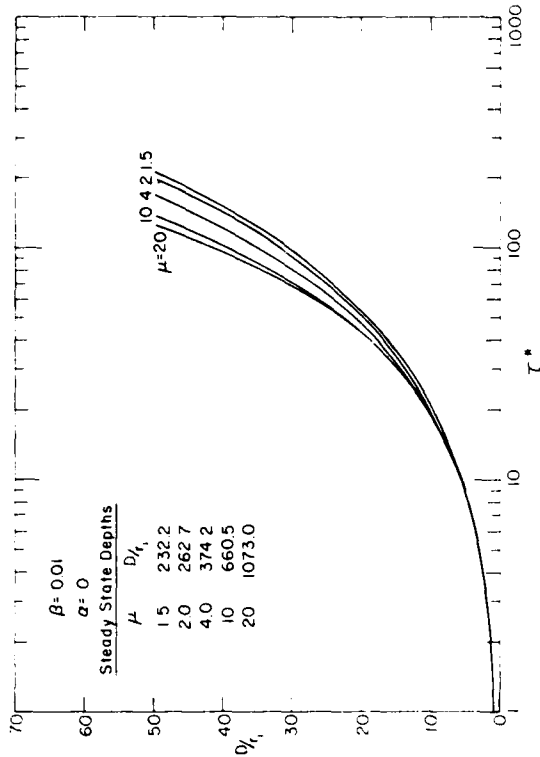

Figure A74.

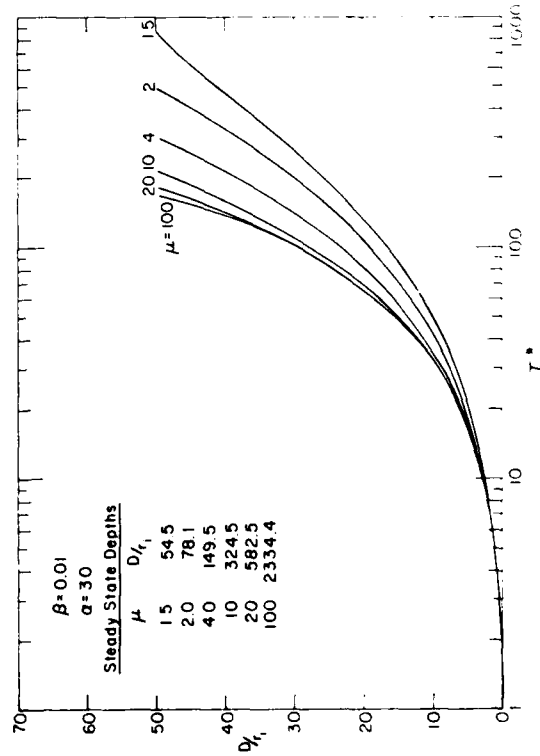

Figure A75.

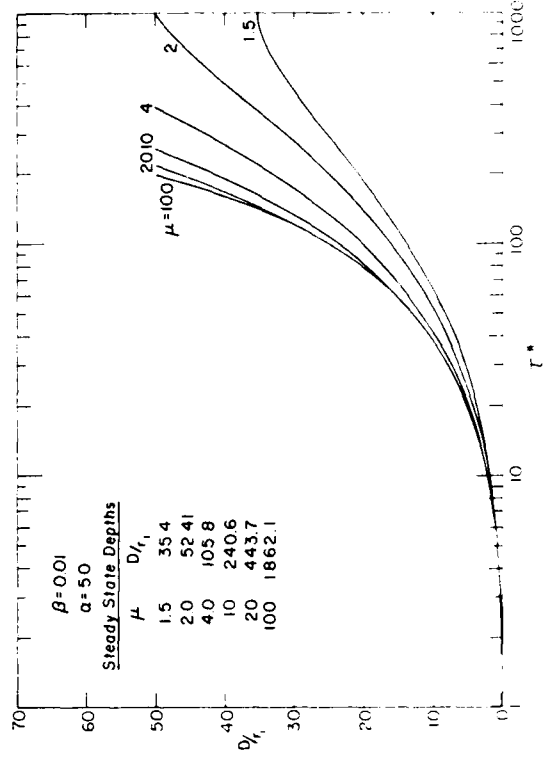

Figure A76.

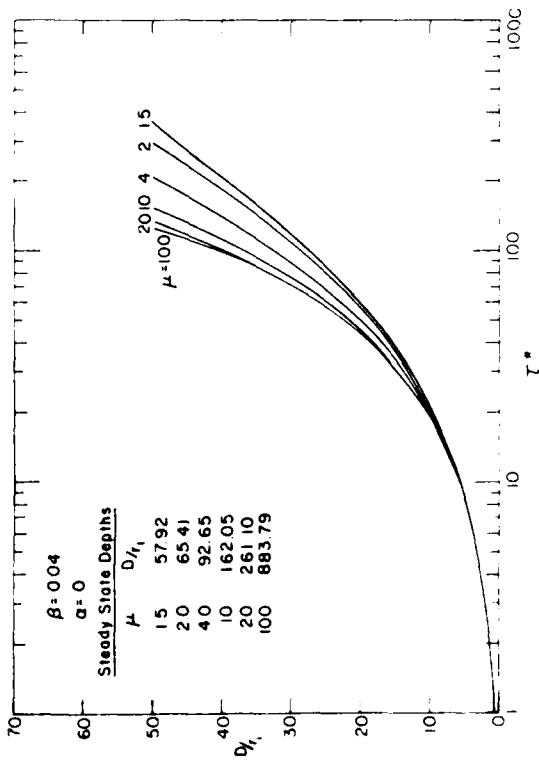

Figure A77.

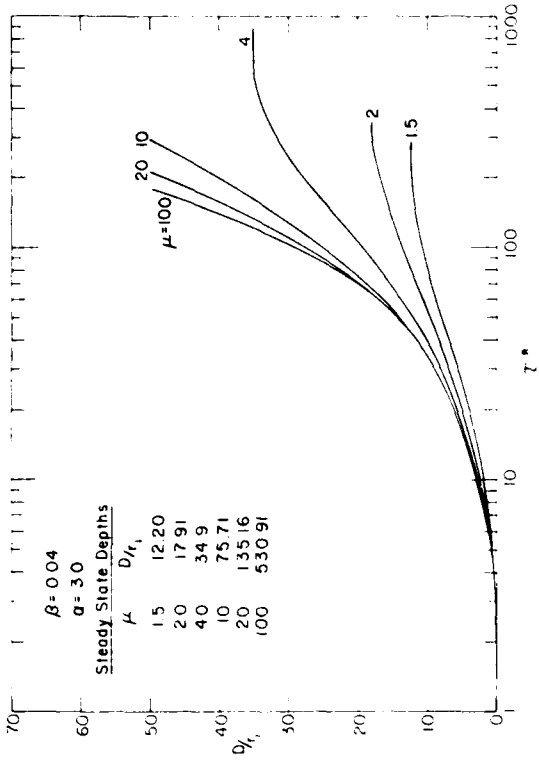

Figure A78.

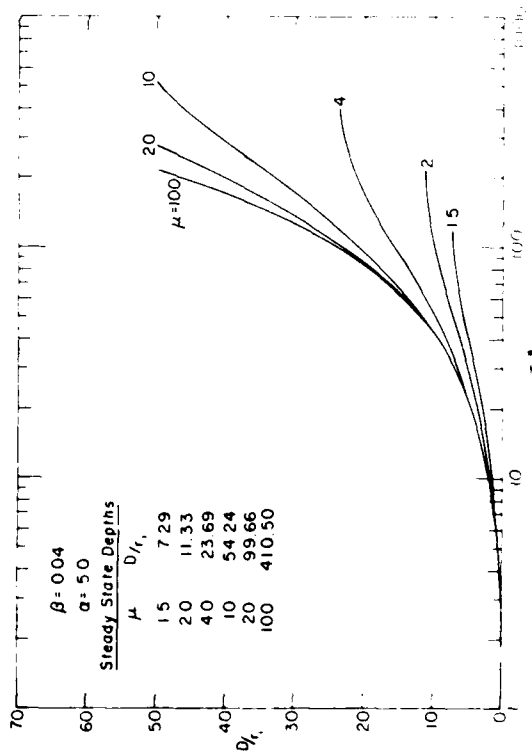

Figure A79.

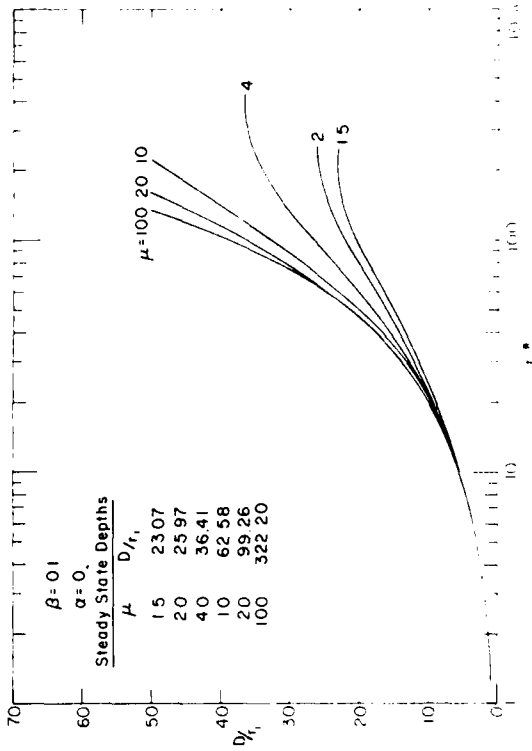

Figure A80.

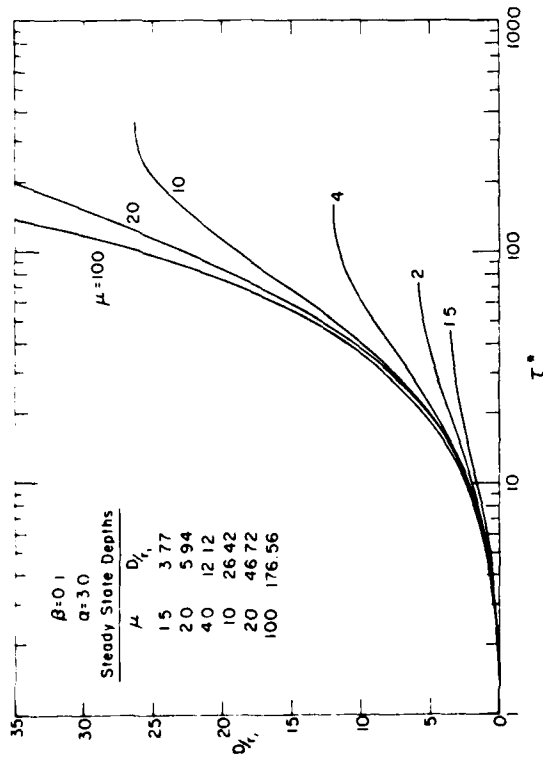

Figure A81.

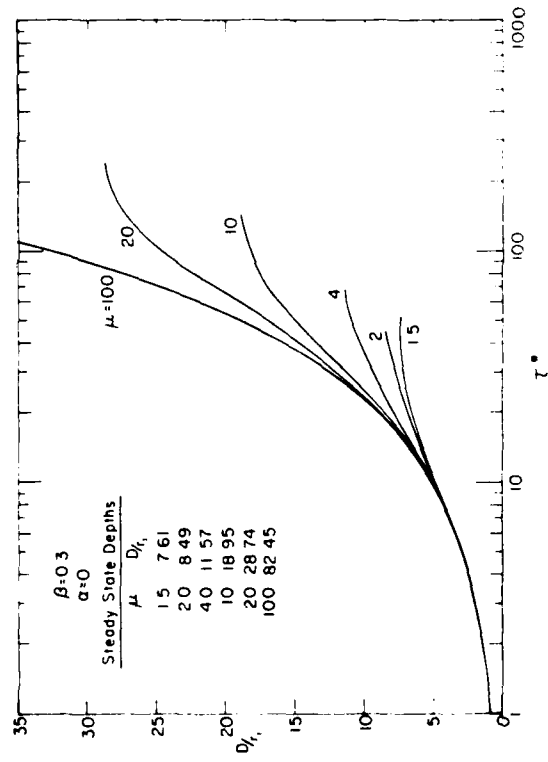

Figure A83.

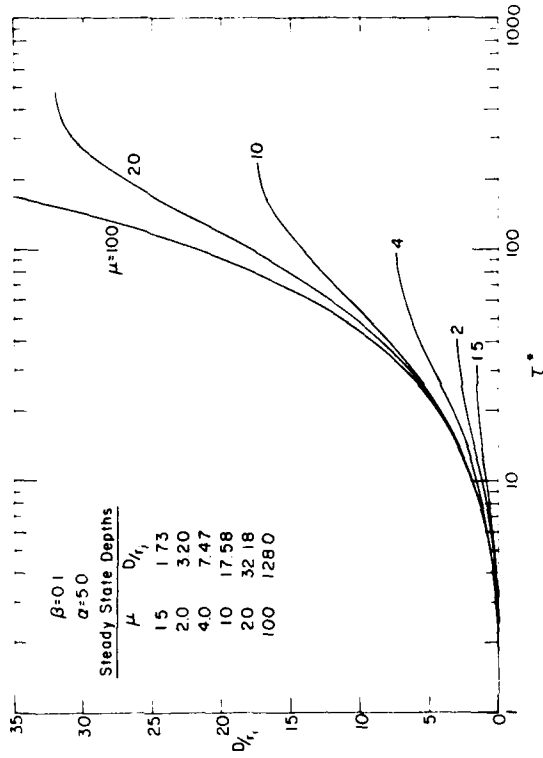

Figure A82.

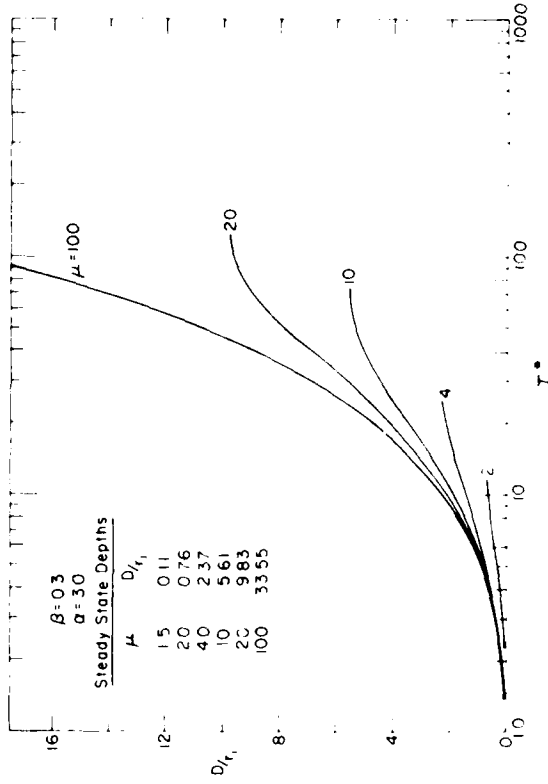

Figure A84.

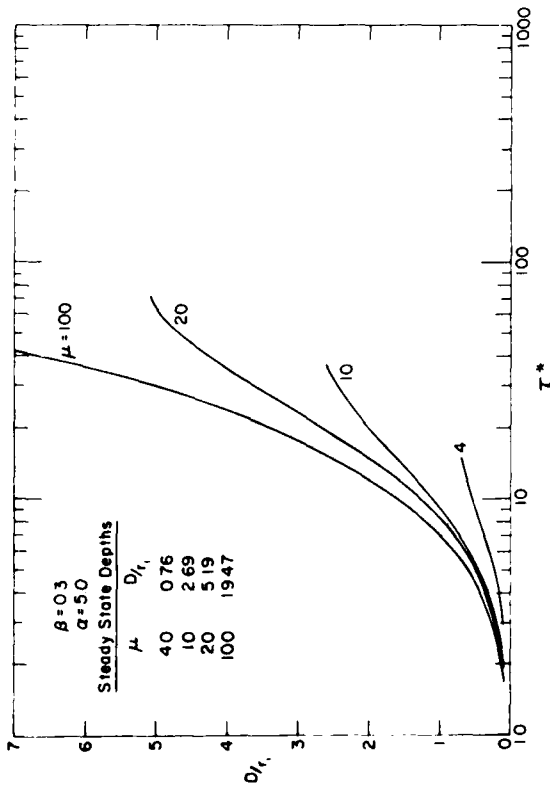

Figure A85.

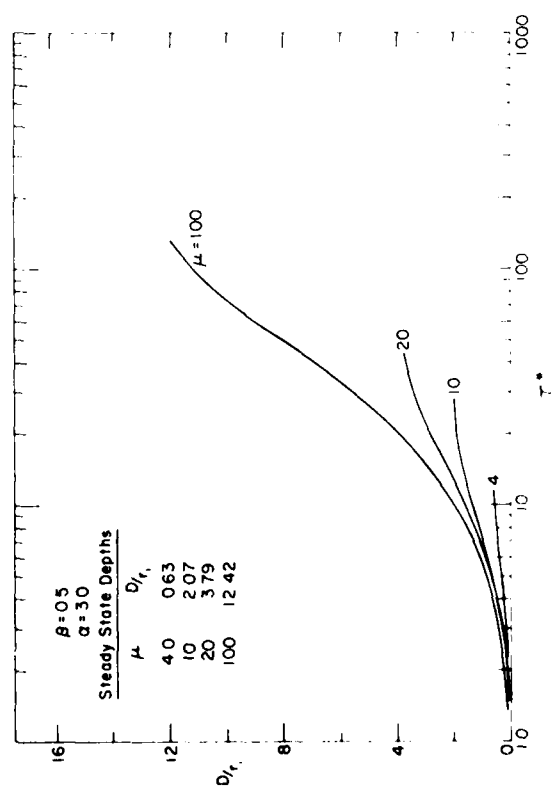

Figure A87.

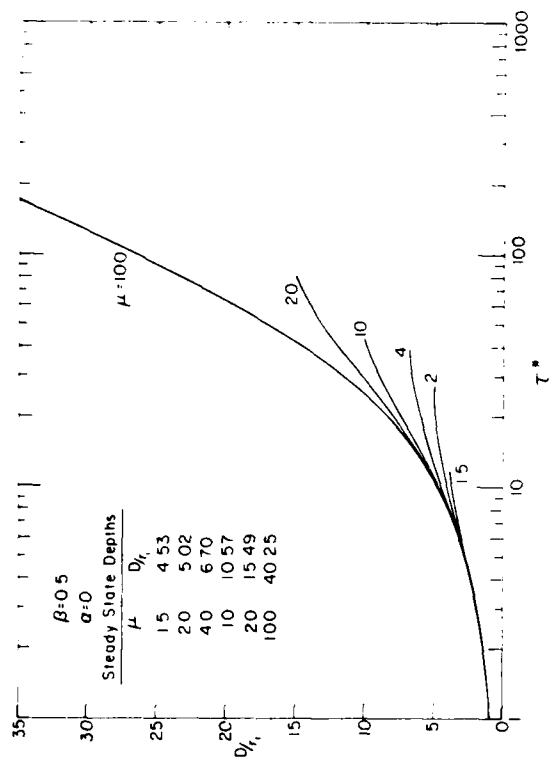

Figure A86.

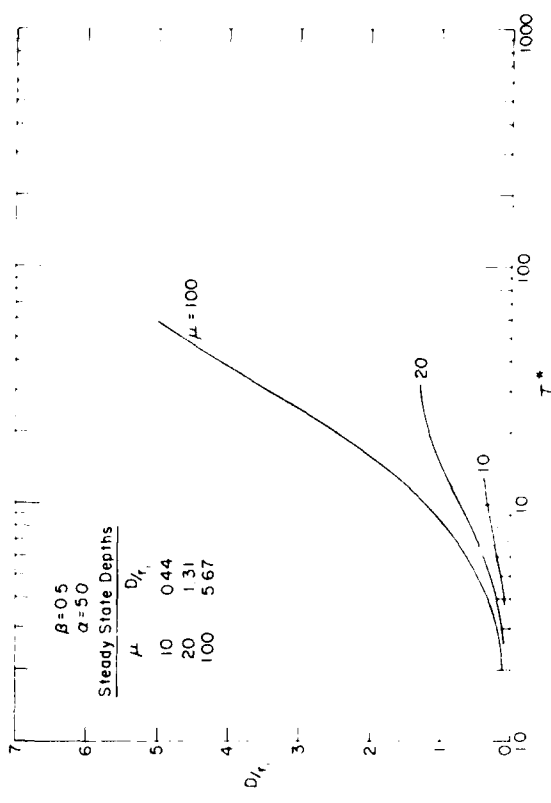

Figure A88.

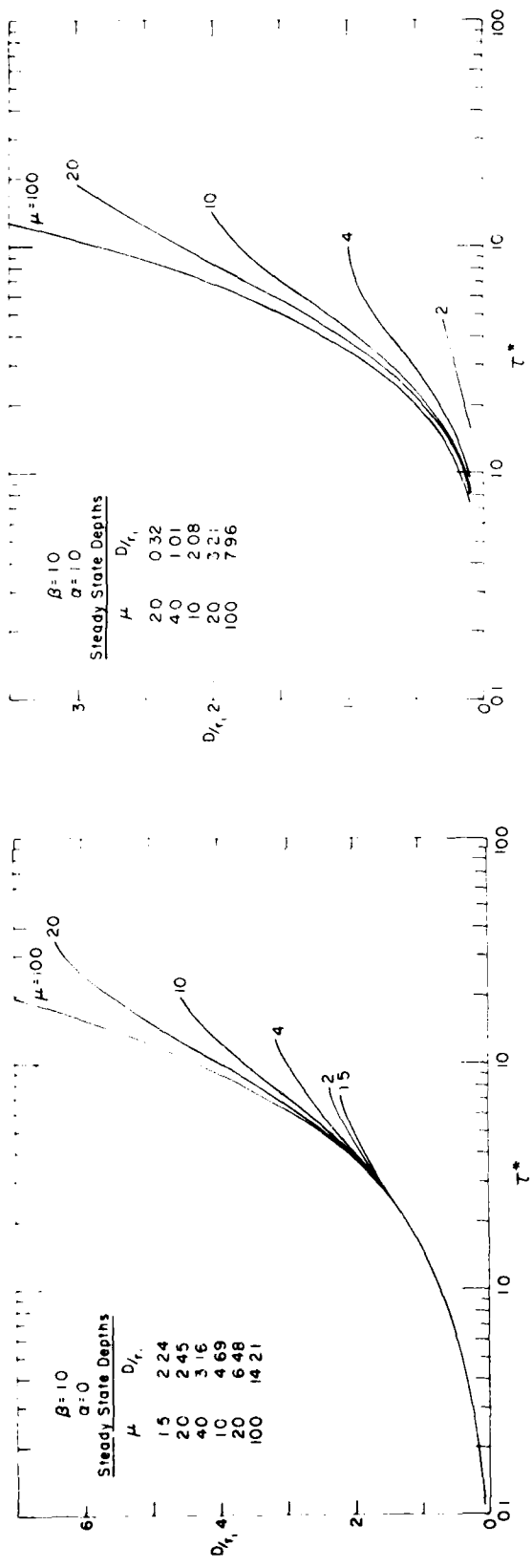

Figure A89.

Figure A90.

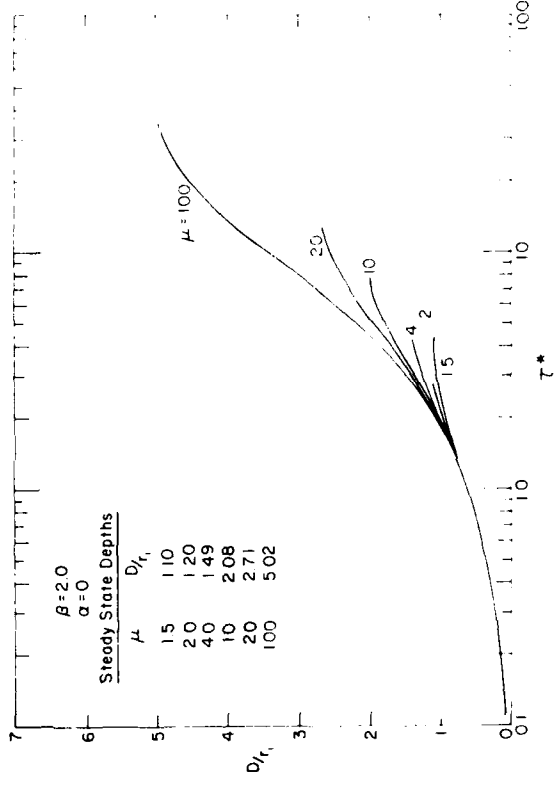
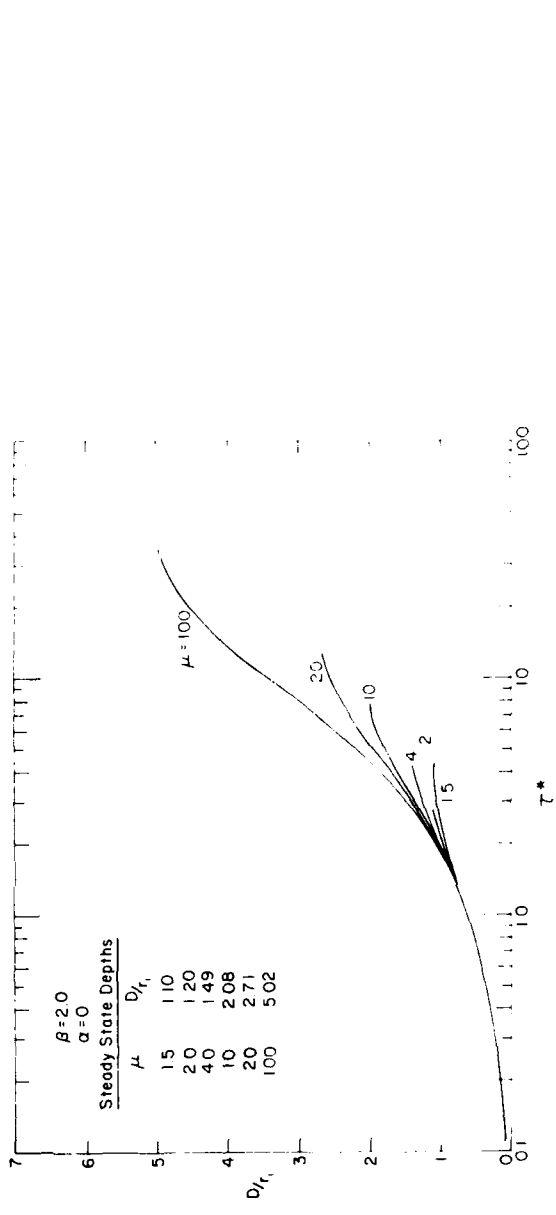

Figure A91.

A facsimile catalog card in Library of Congress MARC format is reproduced below.

Lunardini, Virgil J.

Conduction phase change beneath insulated heated or cooled structures / by Virgil J. Lunardini. Hanover, N.H.: U.S. Cold Regions Research and Engineering Laboratory; Springfield, Va.: available from National Technical Information Service.

vi, 50 p., illus.; 28 cm. (CRREL Report 82-22.)

Bibliography: p. 14.

1. Conduction (heat transfer). 2. Thermal insulation. 3. Phase change. I. United States. Army. Corps of Engineers. II. U.S. Army Cold Regions Research and Engineering Laboratory, Hanover, N.H. III. Series: CRREL Report 82-22.

END

DATE
FILMED

11-18-2

DTIC