

AD-A119-601

VIRGINIA UNIV CHARLOTTESVILLE DEPT OF MECHANICAL AND--ETC F/8 12/1
TRANSVERSE SHEAR STRESSES IN CIRCULARLY CURVED BARS.(U)

MAR 80 C THASANATORN, W D PILKEY

N00014-75-C-0374

UNCLASSIFIED

UVA/525303/MAE80/107

NL

1 of 1
ADs
REQ



END
DATE
FILMED
DTIC

①

AD A119601

TRANSVERSE SHEAR STRESSES IN CIRCULARLY CURVED BARS

Technical Report

Contract No. N00014-75-C0374

Office of Naval Research
800 N. Quincy Street
Arlington, Virginia 22217

Attn: Dr. N. Perrone

Submitted by:

C. Thasanatorn

and

W. D. Pilkey

Department of Mechanical and Aerospace Engineering
RESEARCH LABORATORIES FOR THE ENGINEERING SCIENCES
SCHOOL OF ENGINEERING AND APPLIED SCIENCE
UNIVERSITY OF VIRGINIA
CHARLOTTESVILLE, VIRGINIA

DTIC
SELECTED
SEP 27 1982
D
H

PHOTOCOPY

Report No. UVA/525303/MAE80/107

March 1980

DISTRIBUTION STATEMENT A
Approved for public release;
Distribution Unlimited

82 00 117

REPORT DOCUMENTATION PAGE		READ INSTRUCTIONS BEFORE COMPLETING FORM
1. REPORT NUMBER UVA/525303/MAE80/107	2. GOVT ACCESSION NO. AD-A119601	3. RECIPIENT'S CATALOG NUMBER
4. TITLE (and Subtitle) Transverse Shear Stresses in Circularly Curved Bar	5. TYPE OF REPORT & PERIOD COVERED Technical Report	
	6. PERFORMING ORG. REPORT NUMBER	
7. AUTHOR(s) W. D. Pilkey and C. Thasanatorn	8. CONTRACT OR GRANT NUMBER(s) N00014-75-C0374	
9. PERFORMING ORGANIZATION NAME AND ADDRESS Department of Mechanical and Aerospace Engineering University of Virginia Charlottesville, Virginia 22901	10. PROGRAM ELEMENT, PROJECT, TASK AREA & WORK UNIT NUMBERS	
11. CONTROLLING OFFICE NAME AND ADDRESS Structural Mechanics Program Office of Naval Research Arlington, Virginia 22217	12. REPORT DATE March 1980	
	13. NUMBER OF PAGES	
14. MONITORING AGENCY NAME & ADDRESS (if different from Controlling Office)	15. SECURITY CLASS. (of this report) Unclassified	
	15a. DECLASSIFICATION/DOWNGRADING SCHEDULE	
16. DISTRIBUTION STATEMENT (of this Report) Approved for public release; distribution unlimited.		
17. DISTRIBUTION STATEMENT (of the abstract entered in Block 20, if different from Report)		
18. SUPPLEMENTARY NOTES		
19. KEY WORDS (Continue on reverse side if necessary and identify by block number) Shear Stresses Elasticity Shear Finite elements Stress Analysis Solid mechanics Curved Bar Warping Stresses		
20. ABSTRACT (Continue on reverse side if necessary and identify by block number) ➤ Mathematical formulations and solution techniques are presented for the stress analysis of circularly curved bars subjected to transverse forces in the plane of curvature. The formulation follows the semi-inverse method of Saint Venant, using a stress function. Numerical results are obtained with a finite element method, which accepts curved bars with cross-sectional geometries.		

TRANSVERSE SHEAR STRESSES IN CIRCULARLY
CURVED BARS

By Chirasak Thasanatorn¹ and Walter D. Pilkey², M. ASCE

Introduction

The exact stress determination of a circularly curved bar subjected to pure bending and shear forces in the plane of curvature requires the solution of a boundary-value problem of three-dimensional elasticity. This presents formidable complications because of the difficulty of satisfying the boundary conditions. Few elasticity problems for curved bars have been solved. Analytical solutions of a curved bar with circular cross sections were developed by Golovin, as presented in Timoshenko (2). Also given in Reference 2 are plane elasticity solutions for curved bars of small width. A so-called strength-of-material theory of curved bars was developed by Winkler using assumptions analogous to the Bernoulli-Euler hypothesis of straight beam theory. In this case, the equilibrium conditions are satisfied in an average sense.

This paper presents a method for the stress analysis of a circularly curved bar subjected to a transverse end force in the plane of the bar curvature. This formulation follows the semi-inverse method of Saint Venant, using a stress function. The assumption that stresses on any cross section depend upon forces at that particular cross section permits the three-dimensional elasticity problem to be reduced to determining the stresses on the cross section of the curved bar. The stress solutions obtained from this structural model may be extended to more general cases of

¹Research Scientist, Hydronautics, Inc., Laurel, Maryland, 20810

²Professor of Applied Mechanics, University of Virginia, Charlottesville, Virginia, 22901

loading by appealing to Saint Venant's principle, provided that the cross section of interest is sufficiently far from any points of rapid variation in the internal forces. Finally, a finite element method, which is suitable for a curved bar with complicated cross-sectional geometry, is used to determine the stresses on the cross section.

Torsional stresses for circularly curved bars are treated in Reference 1.

Accession For	
NTIS GRA&I	<input checked="" type="checkbox"/>
DTIC TAB	<input type="checkbox"/>
Unannounced	<input type="checkbox"/>
Justification	
By _____	
Distribution/	
Availability Codes	
Dist	Avail and/or Special
A	

ELASTICITY FORMULATION

Consider a planar curved bar of initial curvature R , with one end fixed and the other end free, as shown in Fig. 1. The bar is subjected to a transverse radial force passing through the shear center at the free end. Assume: (1) the material is linearly elastic, continuous, homogeneous, and isotropic; (2) the curved bar is planar, lying in the x - z plane with the longitudinal axis coinciding with the geometric centroid of the cross section; (3) the curved bar can have any arbitrary cross-sectional configuration but must be prismatic; (4) the body forces are small compared to the magnitudes of the stresses and can be neglected; (5) the stresses at any cross section are assumed to depend upon only the internal forces at that cross section; and finally (6) the normal stress distribution is assumed to follow a hyperbolic law in the radial direction. The curved bar is modeled with fixed-free ends to simplify the mathematical formulation. For this case the variations of internal forces along the curved bar axis are either constant or are a function of sine or cosine functions.

From the overall equilibrium conditions of the bar of Fig. 1, the internal forces at any cross section along the bar axis are

$$\begin{aligned} P &= W \sin \theta; M_y = -WR \sin \theta; V_z = W \cos \theta \\ M_x &= M_z = 0; V_y = 0 \end{aligned} \quad (1)$$

The twisting moment M_x vanishes due to the assumption that the force W passes through the shear center of the cross section.

From assumption 5 (above) and Eq. (1), the three-dimensional elasticity problem may be reduced to a two-dimensional one by expressing the stresses in the form

$$\begin{aligned} \sigma_x &= \bar{\sigma}_x(y, z) \sin \theta; \sigma_y = \bar{\sigma}_y(y, z) \sin \theta; \sigma_z = \bar{\sigma}_z(y, z) \sin \theta \\ \tau_{yz} &= \bar{\tau}_{yz}(y, z) \sin \theta; \tau_{xy} = \bar{\tau}_{xy}(y, z) \cos \theta; \tau_{xz} = \bar{\tau}_{xz}(y, z) \cos \theta \end{aligned}$$

where $\bar{\sigma}_x$, $\bar{\sigma}_y$, $\bar{\sigma}_z$, $\bar{\tau}_{yz}$, $\bar{\tau}_{xy}$ and $\bar{\tau}_{xz}$ are functions of cross-sectional

coordinates (y, z) only. Assumptions 5 and 6 suggest trying to satisfy the stress equilibrium equations of elasticity theory by assuming a normal stress distribution in the form

$$\sigma_x = -\frac{ER^2}{(R+z)} [C_0 + C_y y + C_z z] \sin\theta \quad (3)$$

where C_0 , C_y , and C_z are constants to be determined. The stress expressions that automatically satisfy the three stress equilibrium equations can be expressed in terms of the two stress functions $\phi(y, z)$ and $\psi(y, z)$

$$\sigma_z = -\frac{ER^2}{(R+z)} [C_0 + C_y y + C_z z] \sin\theta \quad (4)$$

$$\sigma_y = \left\{ \frac{R^2}{(R+z)^2} \phi_{,zz} - \frac{R}{(R+z)} \psi_{,zz} + \frac{1}{2} \frac{ER^2}{(R+z)^2} \frac{dF(z)}{dz} [F(z) - y] [C_0 + 2C_y F(z)] \right\} \sin\theta \quad (5)$$

$$\sigma_z = \left(\frac{R^2}{(R+z)^2} \phi_{,yy} - \frac{R}{(R+z)} \psi_{,yy} + \frac{1}{2} \frac{ER^2}{(R+z)} \left\{ C_0 \left[\frac{G(y)}{(R+z)} - 1 \right] + C_z \left[\frac{G^2(y)}{(R+z)} - \frac{2RG(y)}{(R+z)} + 2R - (R+z) \right] \right\} \right) \sin\theta \quad (6)$$

$$\tau_{xy} = \left\{ \frac{R^2}{(R+z)^2} \phi_{,yz} + \frac{1}{2} \frac{ER^2}{(R+z)^2} (C_0 y + C_y y^2) - \frac{1}{2} \frac{ER^2}{(R+z)^2} F(z) [C_0 + C_y F(z)] \right\} \cos\theta \quad (7)$$

$$\tau_{xz} = \left(-\frac{R^2}{(R+z)^2} \phi_{,yy} + \frac{1}{2} \frac{ER^2}{(R+z)^2} [C_0 (R+z) + C_z (z^2 - R^2)] - \frac{1}{2} \frac{ER^2}{(R+z)^2} G(y) \left\{ C_0 + C_z [G(y) - 2R] \right\} \right) \cos\theta \quad (8)$$

$$\tau_{yz} = \left\{ \frac{R}{(R+z)} \psi_{,yz} - \frac{R^2}{(R+z)^2} \phi_{,yz} - \frac{ER^2}{(R+z)^2} (C_0 y + C_y y^2) + \frac{1}{2} \frac{ER^2}{(R+z)^2} F(z) [C_0 + C_y F(z)] \right\} \sin\theta \quad (9)$$

where $F(z)$ and $G(y)$ are defined along the cross-sectional boundary.

The stress expressions in Eqs. (4) - (9) are derived independent of the displacements u , v , and w . The stress components, or more specifically the stress functions ϕ and ψ , can not be taken as arbitrary functions of (θ, y, z) but are subject to the two stress compatibility conditions to ensure the existence of displacements u , v , and w corresponding to these stresses. A set of consistent stress-displacement relations can be derived by using the Hellinger-Reissner variational principle, which is a mixed principle. Then, two independent stress compatibility conditions can be derived from the five consistent stress-displacement equations. They are

$$\begin{aligned} \sigma_{y,rr} + \sigma_{r,yy} - 2\tau_{yr,yr} - \nu[\sigma_{y,yy} + \sigma_{r,rr} + 2\tau_{yr,yr}] \\ = -2\nu \frac{ER^2}{r^3} (C_0 + C_y y - C_z R) \sin\theta \end{aligned} \quad (10)$$

$$\begin{aligned} \sigma_{y,\theta r} - \frac{1}{r} \sigma_{y,\theta} + \nu \left\{ -\sigma_{r,\theta r} + \frac{1}{r} \sigma_{r,\theta} - \frac{2ER^2}{r^2} [C_0 + C_y y + \frac{1}{2} C_z (r - 2R)] \cos\theta \right\} \\ + (1 + \nu) \left[-\tau_{yr,\theta r} + r^2 \left(\frac{\tau_{\theta r}}{r} \right)_{,yy} - r^2 \left(\frac{\tau_{\theta r}}{r} \right)_{,yr} \right] = 0 \end{aligned} \quad (11)$$

where $r = (R + z)$. Cartesian and cylindrical coordinates are used interchangeably as convenience dictates. The constants C_0 , C_y , and C_z in the assumed normal stress expression of Eq. (2) are determined from the following equilibrium conditions for any section of the curved bar.

$$\int_A \int \sigma_x dydz = W \sin\theta \quad (12)$$

$$\int_A \int y \sigma_x dydz = 0 \quad (13)$$

$$\int_A \int z \sigma_x dydz = WR \sin\theta \quad (14)$$

The constants C_0 , C_y , and C_z are found to be

$$C_0 = 0; \quad C_y = \frac{W I_{yz}}{E(I_y I_z - I_{yz}^2)}; \quad C_z = \frac{W I_z}{E(I_y I_z - I_{yz}^2)} \quad (15)$$

where

$$I_y = \iint_A \frac{z^2}{(1+z/R)} dydz; \quad I_z = \iint_A \frac{y^2}{(1+z/R)} dydz; \quad \text{and } I_{yz} = \iint_A \frac{yz}{(1+z/R)} dydz$$

By substituting Eqs. (4) - (9) into (10) and (11), the two governing partial differential equations for the stress functions ϕ and Ψ can be obtained.

$$\begin{aligned} & \frac{R^2}{(R+z)^2} \phi_{,zzzz} - \frac{4R^2}{(R+z)^3} \phi_{,zzz} + \frac{6R^2}{(R+z)^4} \phi_{,zz} - \frac{R}{(R+z)} \Psi_{,zzzz} \\ & + \frac{2R}{(R+z)^2} \Psi_{,zzz} - \frac{2R}{(R+z)^3} \Psi_{,zz} + \frac{R^2}{(R+z)^2} \phi_{,yyyy} - \frac{R}{(R+z)} \Psi_{,yyyy} \\ & - \frac{2R}{(R+z)} \Psi_{,yyzz} + \frac{2R}{(R+z)^2} \Psi_{,yyz} + \frac{2R^2}{(R+z)^2} \phi_{,yyzz} - \frac{4R^2}{(R+z)^3} \phi_{,yyz} \\ & - \nu \left\{ \frac{2R^2}{(R+z)^2} \phi_{,yyzz} - \frac{2R}{(R+z)} \Psi_{,yyzz} - \frac{4R^2}{(R+z)^3} \phi_{,yyz} + \frac{6R^2}{(R+z)^4} \phi_{,yy} \right. \\ & + \frac{2R^2}{(R+z)^2} \Psi_{,yyz} - \frac{2R}{(R+z)^3} \Psi_{,yy} + \frac{2R}{(R+z)} \Psi_{,yyzz} - \frac{2R}{(R+z)^2} \Psi_{,yyz} \\ & - \frac{2R^2}{(R+z)^2} \phi_{,yyzz} + \frac{4R^2}{(R+z)^3} \phi_{,yyz} \left. \left[+ \left[\frac{1}{2} \frac{ER^2}{(R+z)^2} \frac{dF(z)}{dz} (F(z) - y) \right. \right. \right. \\ & \times (C_0 + 2C_y F(z)) \left. \left. \right]_{,zz} + \frac{1}{2} \frac{ER^2}{(R+z)} \left[\frac{C_0}{(R+z)} \frac{d^2G(y)}{dy^2} + C_z \left(\frac{2}{(R+z)} G(y) \right. \right. \right. \\ & \times \left. \left. \frac{d^2G(y)}{dy^2} + \frac{2}{(R+z)} \left(\frac{dG}{dy} \right)^2 - \frac{2R}{(R+z)} \frac{d^2G}{dy^2} \right] - \frac{2ER^2}{(R+z)^3} (C_0 + 2C_y y) \right. \\ & - \nu \left. \left[\frac{1}{2} \frac{ER^2}{(R+z)} \left[C_0 \left(\frac{G(y)}{(R+z)} - 1 \right) + C_z \left(\frac{G^2(y)}{(R+z)} - \frac{2FG(y)}{(R+z)} + R - z \right) \right] \right]_{,zz} \right. \\ & \left. + \frac{2ER^2}{(R+z)^3} (C_0 + 2C_y y) + \frac{2ER^2}{(R+z)^3} (C_0 + C_y y - C_z R) \right\} = 0 \end{aligned} \tag{16}$$

$$\begin{aligned}
& \frac{R^2}{(R+z)^2} \phi_{,zzz} - \frac{3R^2}{(R+z)^3} \phi_{,zz} - \frac{R}{(R+z)} \psi_{,zzz} + \frac{2R}{(R+z)^2} \psi_{,zz} \\
& + \nu \left\{ - \frac{R^2}{(R+z)^2} \phi_{,yyz} + \frac{3R^2}{(R+z)^3} \phi_{,yy} + \frac{R}{(R+z)} \psi_{,yyz} - \frac{2R}{(R+z)^2} \psi_{,yy} \right\} \\
& + (1+\nu) \left\{ - \frac{R}{(R+z)} \psi_{,yyz} + \frac{R^2}{(R+z)^2} \phi_{,yyz} - \frac{R^2}{(R+z)} \phi_{,yyyy} - \frac{R^2}{(R+z)} \phi_{,yyzz} \right. \\
& \left. + \frac{3R^2}{(R+z)^2} \phi_{,yyz} \right\} + (R+z) \left[\frac{1}{2} \frac{ER^2}{(R+z)^3} \frac{dF(z)}{dz} (F(z) - y)(C_0 + 2C_y F(z)) \right]_{,z} \\
& - (R+z) \left[\frac{1}{2} \frac{E\nu R^2}{(R+z)^2} \left[C_0 \left(\frac{G(y)}{(R+z)} - 1 \right) + C_z \left(\frac{G^2(y)}{(R+z)} - \frac{2RG(y)}{(R+z)} + R - z \right) \right] \right]_{,z} \\
& - \frac{2E\nu R^2}{(R+z)^2} \left(C_0 + C_y y + \frac{1}{2} C_z (z - R) \right) + (1+\nu) \left\{ \frac{1}{2} \frac{FR^2}{(R+z)^2} (C_0 + 2C_y y) \right. \\
& \left. - \frac{1}{2} \frac{ER^2}{(R+z)} [G(y) [C_0 + C_z (G(y) - 2R)]] \right\}_{,yy} \\
& + \frac{3}{2} \frac{ER^2}{(R+z)^2} (C_0 + 2C_y y) \left\{ = 0 \right.
\end{aligned} \tag{17}$$

The traction-free boundary conditions on the lateral surface of a curved bar yield the values

$$\phi_{,y} = \phi_{,z} = 0; \quad \psi_{,y} = \psi_{,z} = 0 \tag{18}$$

for the stress functions along the cross-sectional boundaries.

FINITE ELEMENT ANALYSIS

The governing equations for the stress functions ϕ and ψ as given in Equations (16) and (17) are too complex to be suitable for closed form solutions. A variationally based finite element procedure will be applied to obtain the solutions. The problem of integrating the partial differential equations (16) and (17) subject to boundary conditions (18) may be transformed into the problem of finding the unknown stress functions ϕ and ψ which make stationary a functional subject to the same boundary conditions. The functional may be expressed in matrix form as

$$\Pi = \iint [\{\phi\}^T [C] \{\phi\} - \{\phi\}^T \{F\} + D] dydz \quad (19)$$

in which

$$\{\phi\} = \begin{Bmatrix} \phi, yy \\ \phi, zz \\ \phi, yz \\ \psi, yy \\ \psi, zz \\ \psi, yz \end{Bmatrix} \quad (20)$$

$$\begin{aligned}
 & -v \frac{R^4}{(R+z)^2} (C_y y + C_z z) + v \frac{R^4}{(R+z)^3} C_y F(z) (F(z) - y) \frac{dF}{dz} \\
 & - \frac{1}{2} \frac{R^4}{(R+z)^2} C_z \left[\frac{G^2(y)}{(R+z)} - \frac{2RG(y)}{(R+z)} + R - z \right] + \frac{1}{2} \frac{E}{G} \frac{R^4}{(R+z)^3} \\
 & \times C_z \{ z^2 - R^2 G(y) [G(y) - 2R] \} \\
 \hline
 & -v \frac{R^4}{(R+z)^2} (C_y y + C_z z) - \frac{R^4}{(R+z)^3} C_y F(z) [F(z) - y] \frac{dF(z)}{dz} \\
 & + \frac{v}{2} \frac{R^4}{(R+z)^2} C_z \left[\frac{G^2(y)}{(R+z)} - \frac{2RG(y)}{(R+z)} + R - z \right] \\
 \hline
 \{F\} = & - \frac{E}{G} \frac{R^4}{(R+z)^3} C_y [y^2 - F^2(z)] \\
 \hline
 & v \frac{R^3}{(R+z)} (C_y y + C_z z) - v \frac{R^3}{(R+z)^2} C_y F(z) [F(z) - y] \frac{dF(z)}{dz} \\
 & + \frac{1}{2} \frac{R^3}{(R+z)} C_z \left[\frac{G^2(y)}{(R+z)} - \frac{2RG(y)}{(R+z)} + R - z \right] \\
 \hline
 & v \frac{R^3}{(R+z)} (C_y y + C_z z) + \frac{R^3}{(R+z)^2} C_y F(z) [F(z) - y] \frac{dF}{dz} \\
 & - \frac{v}{2} \frac{R^3}{(R+z)} C_z \left[\frac{G^2(y)}{(R+z)} - \frac{2RG(y)}{(R+z)} + R - z \right] \\
 \hline
 & \frac{1}{2} \frac{E}{G} \frac{R^3}{(R+z)^2} C_y [y^2 - F^2(z)]
 \end{aligned}
 \tag{1}$$

$$D = \frac{1}{2} \frac{ER^4}{(R+z)} \left[(C_y y + C_z z)^2 + \frac{1}{4} \frac{1}{(R+z)^2} (C_z z^2)^2 \right. \tag{22}$$

$$\left. - \frac{\nu}{2} \frac{1}{(R+z)} (C_y y + C_z z) (C_z z^2) \right] + \frac{1}{4} (1 + \nu) E \frac{R^4}{(R+z)^3} \left[2(C_y y^2)^2 + (C_z z^2)^2 \right]$$

$$[\begin{array}{cccccc} \frac{(3+2\nu)}{2E} \frac{R^4}{(R+z)^3} & -\frac{1}{2} \frac{\nu}{E} \frac{R^4}{(R+z)^3} & 0 & -\frac{1}{2E} \frac{R^3}{(R+z)^2} & \frac{1}{2} \frac{\nu}{E} \frac{R^3}{(R+z)^2} & 0 \\ -\frac{1}{2} \frac{\nu}{E} \frac{R^4}{(R+z)^3} & \frac{1}{2E} \frac{R^4}{(R+z)^3} & 0 & \frac{\nu}{2E} \frac{R^3}{(R+z)^2} & -\frac{1}{2E} \frac{R^3}{(R+z)^2} & 0 \\ 0 & 0 & \frac{1}{G} \frac{R^4}{(R+z)^3} & 0 & 0 & -\frac{1}{2G} \frac{R^3}{(R+z)^2} \\ -\frac{1}{2E} \frac{R^3}{(R+z)^2} & \frac{1}{2} \frac{\nu}{E} \frac{R^3}{(R+z)^2} & 0 & \frac{1}{2E} \frac{R^2}{(R+z)} & -\frac{\nu}{2E} \frac{R^2}{(R+z)} & 0 \\ \frac{\nu}{2E} \frac{R^3}{(R+z)^2} & -\frac{1}{2E} \frac{R^3}{(R+z)^2} & 0 & -\frac{\nu}{2E} \frac{R^2}{(R+z)} & \frac{1}{2E} \frac{R^2}{(R+z)} & 0 \\ 0 & 0 & -\frac{1}{2G} \frac{R^3}{(R+z)^2} & 0 & 0 & \frac{1}{2G} \frac{R^2}{(R+z)} \end{array}] \tag{25}$$

The procedure will be to idealize the cross-sectional domain by an assemblage of triangular elements. The functional Π may be approximated as the sum of functionals evaluated for each element. Mathematically, the functional may be written as

$$\Pi = \sum_{i=1}^M \Pi_i^{(e)} \quad (24)$$

where i indicates the element number and M is the total number of elements. At node j the stress functions and their first derivatives (slopes) with respect to y and z are chosen as the unknown nodal parameters and are expressed in matrix form as

$$\{\phi_j\}^T = [\phi_j \quad -\phi_{,y_j} \quad \phi_{,z_j} \quad \psi_j \quad -\psi_{,y_j} \quad \psi_{,z_j}] \quad (25)$$

The stress function behavior within each element may be written in terms of their nodal parameters

$$\begin{Bmatrix} \phi(y,z) \\ \psi(y,z) \end{Bmatrix}^e = [N]^e \{\phi_j\}^e \quad (26)$$

where $[N]^e$ is a shape function matrix and $\{\phi_j\}^e$ is a vector of the unknown nodal parameters. The vector of derivatives in Eq. (20) may be obtained by differentiating Eq. (26) with respect to y and z , Thus

$$\{\phi\} = [B]^e \{\phi_j\}^e \quad (27)$$

where elements of matrix $[B]^e$ are the second derivatives of the shape functions with respect to y and z as defined in Eq. (20). The discretized functional for element i is obtained in terms of the unknown nodal parameters by substituting Eq. (27) into (19)

$$\Pi_i^{(e)} = \iint_{A_i} [\{\phi_j^e\}^T [B^e]^T [C] [B^e] \{\phi_j^e\} - \{\phi_j^e\}^T [B^e]^T \{F\} + D] dydz \quad (28)$$

where integration is performed over the element domain A_1 . Finally the total functional is obtained by collecting the contributions from all discretized functionals within the cross-sectional domain.

$$\begin{aligned} \Pi(y, z, \phi_j) = & \sum_{i=1}^M \iint_{A_1} [(\phi_j^e)^T [B^e]^T [C] [B^e] (\phi_j)^T \\ & - (\phi_j^e)^T [B^e]^T [F] + D] dydz \end{aligned} \quad (29)$$

The stationary solution of the functional Π can be derived from the condition that the variation of the functional $\Pi(y, z, \phi_j)$ with respect to the unknown nodal parameters vanishes. That is

$$\delta \Pi(y, z, \phi_j) = \sum_{i=1}^M \frac{\partial \Pi_i}{\partial \phi_j} \delta \phi_j = 0 \quad \text{for } j = 1, 2, \dots, N \quad (30)$$

where N is the number of nodes on the cross section.

NUMERICAL RESULTS

The formulation will be applied to two curved bar cross sections. First, a homogeneous thin curved bar of rectangular cross section will be used so that the calculated stresses can be compared with an analytical solution available from plane elasticity theory. The second example, is chosen to be a curved box section.

Homogeneous Thin Curved Bar of Rectangular Cross Section. The thin rectangular curved bar of Fig. (2a) has a 1 in. (0.0254 m) width, 10 inch (0.254 m) depth, and a radius of curvature of 20 inches (0.508 m). The cross section is subjected to an internal shear force in the radial direction of 10,000 lb (44.48 kN) at its centroid. The discretized model of the cross section is shown in Fig. (2b) and partial computer results are presented in Fig. (3). The stress results obtained by the present formulation are compared in Fig. (4) with those obtained from the plane elasticity theory. The direct shear stresses based on the present formulation are the average values across the bar width.

Homogeneous Curved Box Girder Subjected to Direct Shear Force.

The second problem demonstrates the applicability of the method of analysis to a more complicated cross-sectional configuration. Choose the curved bar section of Fig. (5). It is made of steel with a modulus of elasticity and Poisson's ratio of 30×10^6 psi (206.85 GN/m^2) and 0.3 respectively. The section is subjected to an internal shear force of 100,000 lb (444.8 kN) in the z direction. The finite element idealization of the cross section is shown in Fig. (5). The shear stresses throughout the walls were computed. The average shear stresses across the wall thickness are illustrated in Fig. (6).

CONCLUSION

The paper presents a formulation for the direct (transverse) shear stress analysis of a circularly curved structural member. The formulation is based on the three-dimensional theory of elasticity. The assumption "stresses at any cross section depend only on the internal forces at that particular cross section" enables the three dimensional elasticity theory to be reduced to the determination of the stresses at a particular (two-dimensional) cross section. Although the solution is based on a cantilevered bar with a particular applied loading, this formulation can be used to compute the transverse shear stresses for a circularly curved bar with any boundary conditions and arbitrary loading. Thus, the formulation requires only that the internal forces be known on the cross section where the shear stresses are sought.

ACKNOWLEDGMENTS

This work was supported by the Office of Naval Research.

APPENDIX - REFERENCES

1. Thasanatorn, C., and Pilkey, W.D., "Torsional Stresses in Circularly Curved Bars," Journal of the Structural Division, ASCE, Vol. 105, No. ST11, Proc. Paper 14984, November, 1979, pp. 2327-2342.
2. Timoshenko, S.P., and Goodier, J.N., Theory of Elasticity, 3rd ed., McGraw-Hill Book Co., New York, 1970.

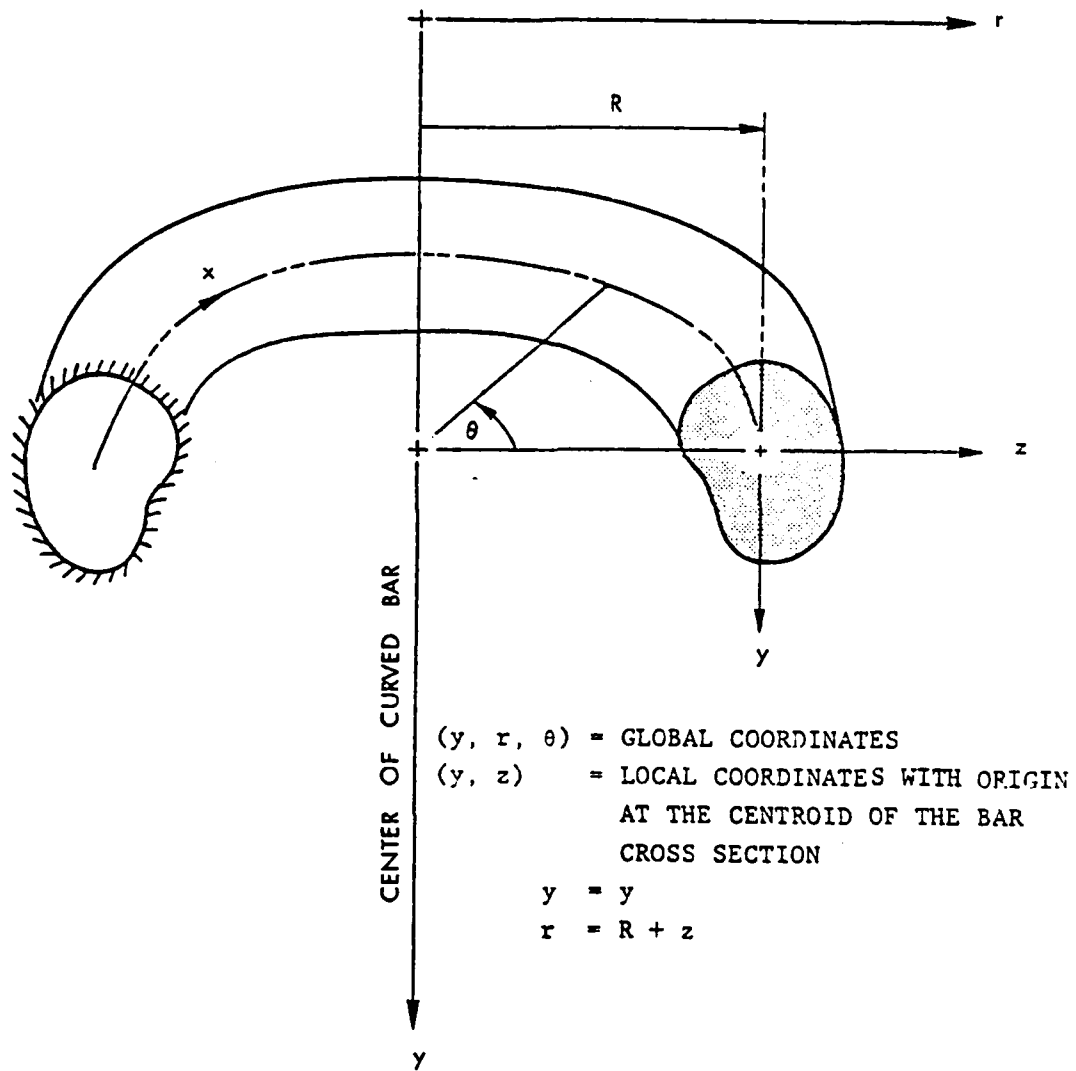
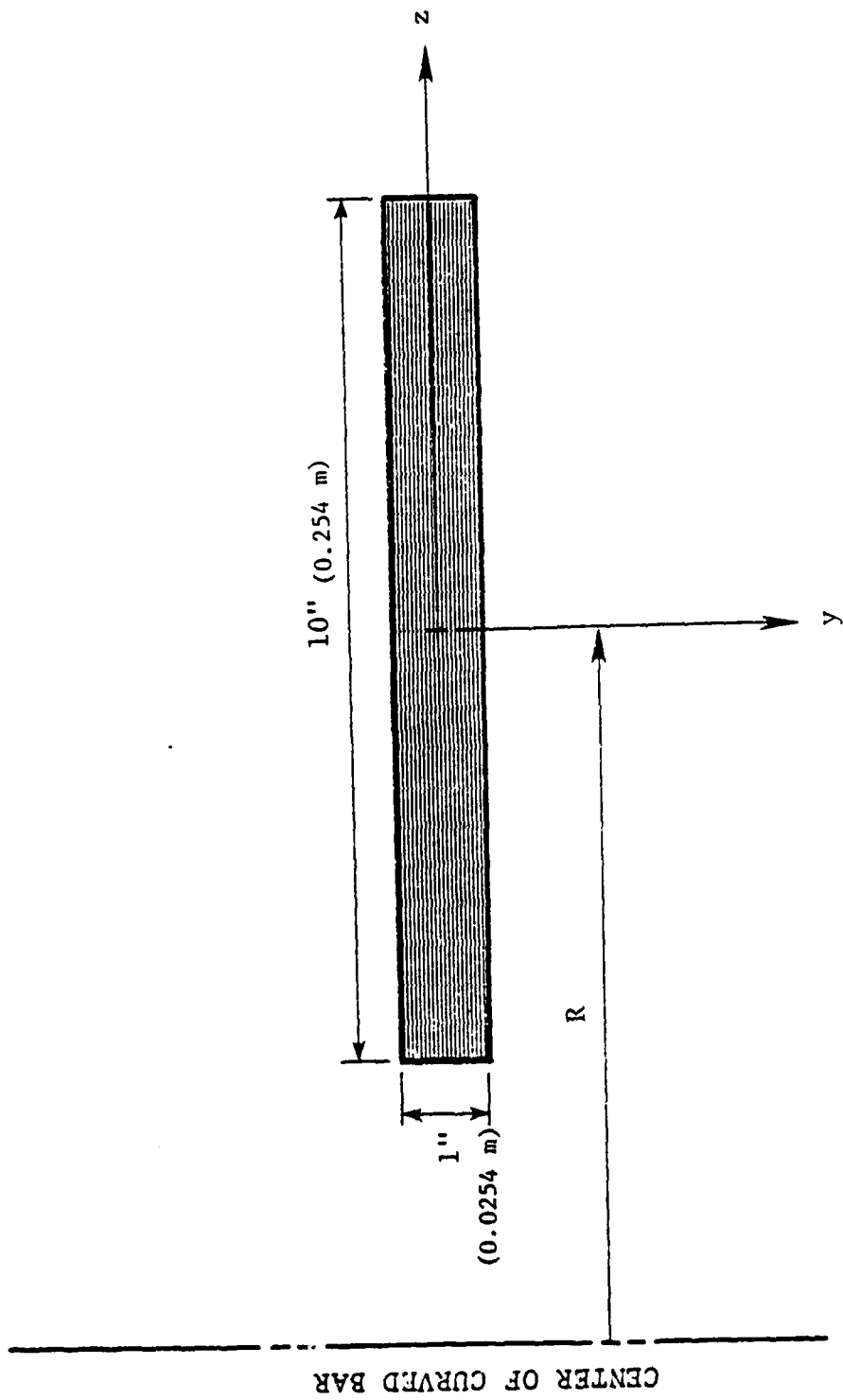
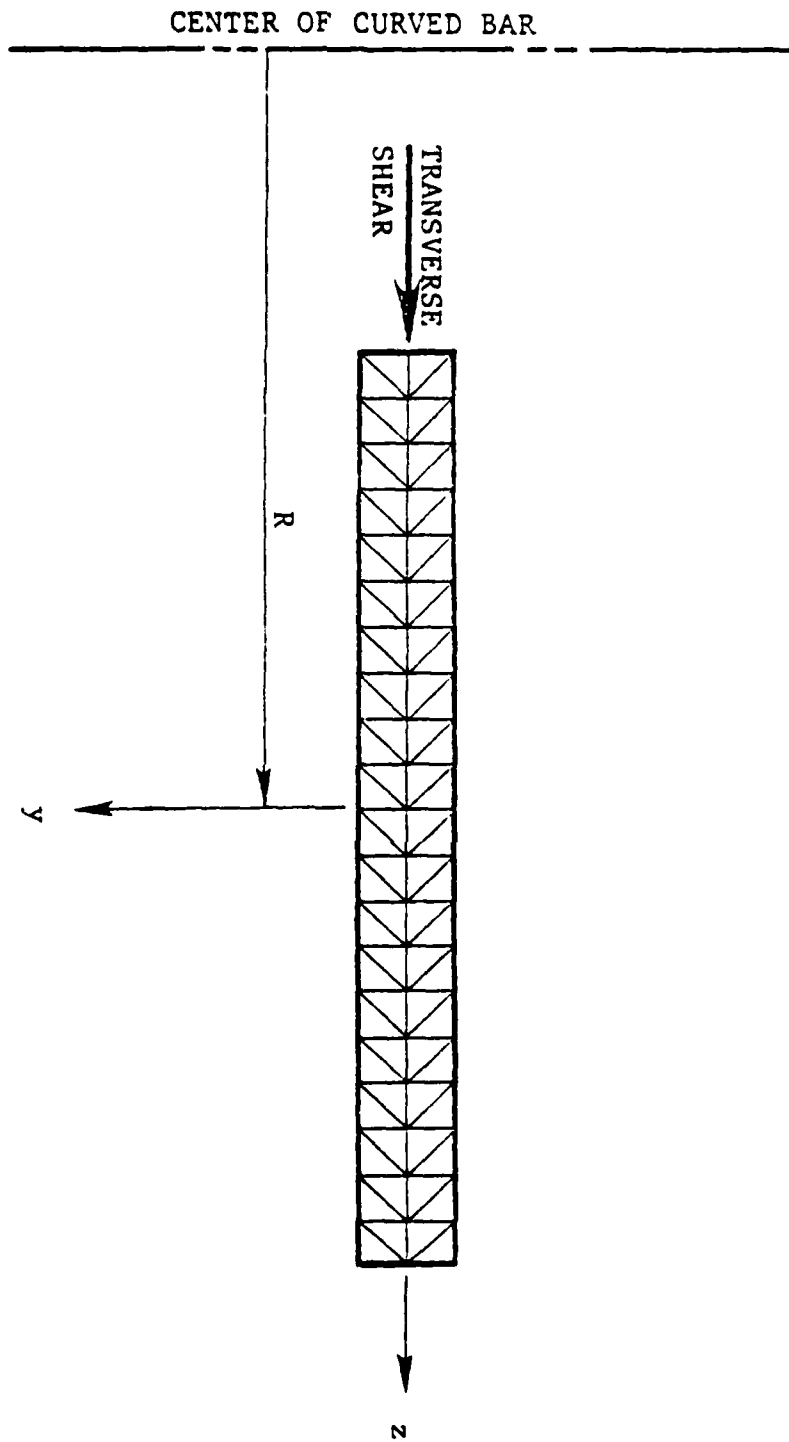

Fig. 1 Structural Model for Direct Shear Stress Analysis



a. Dimensions



b. Finite Element Representation

Fig. 2 Thin Curved Bar Subjected to Transverse Shear

SHEAR STRESSES DUE TO SHEAR FORCES (psi)

COORDINATES OF ELEMENT CENTROID		SHEAR STRESSES	
Y	Z	TXY	TXZ
.813	.313	24.640E+00	24.335E+01
.688	.138	-27.859E+00	19.225E+01
.313	.138	27.859E+00	19.225E+01
.188	.313	-24.640E+00	24.335E+01
.813	.813	22.034E+00	61.280E+01
.688	.638	-21.587E+00	57.500E+01
.313	.638	21.587E+00	57.500E+01
.188	.813	-22.034E+00	61.280E+01
.813	1.313	18.585E+00	90.825E+01
.688	1.138	-18.192E+00	88.061E+01
.313	1.138	18.192E+00	88.061E+01
.188	1.313	-18.585E+00	90.825E+01
.813	1.813	15.448E+00	11.382E+02
.688	1.638	-15.039E+00	11.192E+02
.313	1.638	15.039E+00	11.192E+02
.188	1.813	-15.448E+00	11.382E+02
.813	2.313	12.568E+00	13.105E+02
.688	2.138	-12.148E+00	12.989E+02
.313	2.138	12.148E+00	12.989E+02
.188	2.313	-12.568E+00	13.105E+02
.813	2.813	99.201E-01	14.321E+02
.688	2.638	-94.915E-01	14.267E+02
.313	2.638	94.915E-01	14.267E+02
.188	2.813	-99.201E-01	14.321E+02
.813	3.313	74.804E-01	15.087E+02
.688	3.138	-70.455E-01	15.087E+02
.313	3.138	70.455E-01	15.087E+02
.188	3.313	-74.804E-01	15.087E+02
.813	3.813	52.285E-01	15.457E+02
.688	3.638	-47.894E-01	15.502E+02
.313	3.638	47.894E-01	15.502E+02
.188	3.813	-52.285E-01	15.457E+02
.813	4.313	31.467E-01	15.474E+02
.688	4.138	-27.049E-01	15.558E+02
.313	4.138	27.049E-01	15.558E+02
.188	4.313	-31.467E-01	15.474E+02
.813	4.813	12.189E-01	15.178E+02
.688	4.638	-77.581E-02	15.294E+02
.313	4.638	77.581E-02	15.294E+02
.188	4.813	-12.189E-01	15.178E+02

Fig. 3 Direct Shear Stress Distribution (in psi)
on the Thin Curved Bar Section of Fig. 2

Note: 1 in. = 0.0254 m; 1 psi = 6.895 kN/m²

Coordinates (in.)		Direct Shear Stress (psi)	
y'	z'	Present Formulation	Plane Stress Theory
0.5	0.25	217.80	244.69
0.5	0.75	593.90	650.58
0.5	1.25	894.43	960.69
0.5	1.75	1128.70	1190.69
0.5	2.25	1304.70	1353.40
0.5	2.75	1429.40	1459.40
0.5	3.25	1508.70	1517.50
0.5	3.75	1547.95	1535.01
0.5	4.25	1551.50	1518.06
0.5	4.75	1523.60	1471.81
0.5	5.25	1467.55	1400.58
0.5	5.75	1386.40	1308.04
0.5	6.25	1283.05	1197.31
0.5	6.75	1159.65	1071.03
0.5	7.25	1018.55	931.45
0.5	7.75	861.51	780.52
0.5	8.25	690.26	619.87
0.5	8.75	506.31	450.95
0.5	9.25	310.97	274.96
0.5	9.75	105.47	92.96

Note: 1 in. = 0.0254 m; 1 psi = 6.895 kN/m²

Fig. 4a Comparison of the Shear Stresses (in psi) along the Center Line of a Thin Curved Bar of Fig. 2 Obtained by the Present Formulation with those of Two-Dimensional Plane Stress Theory

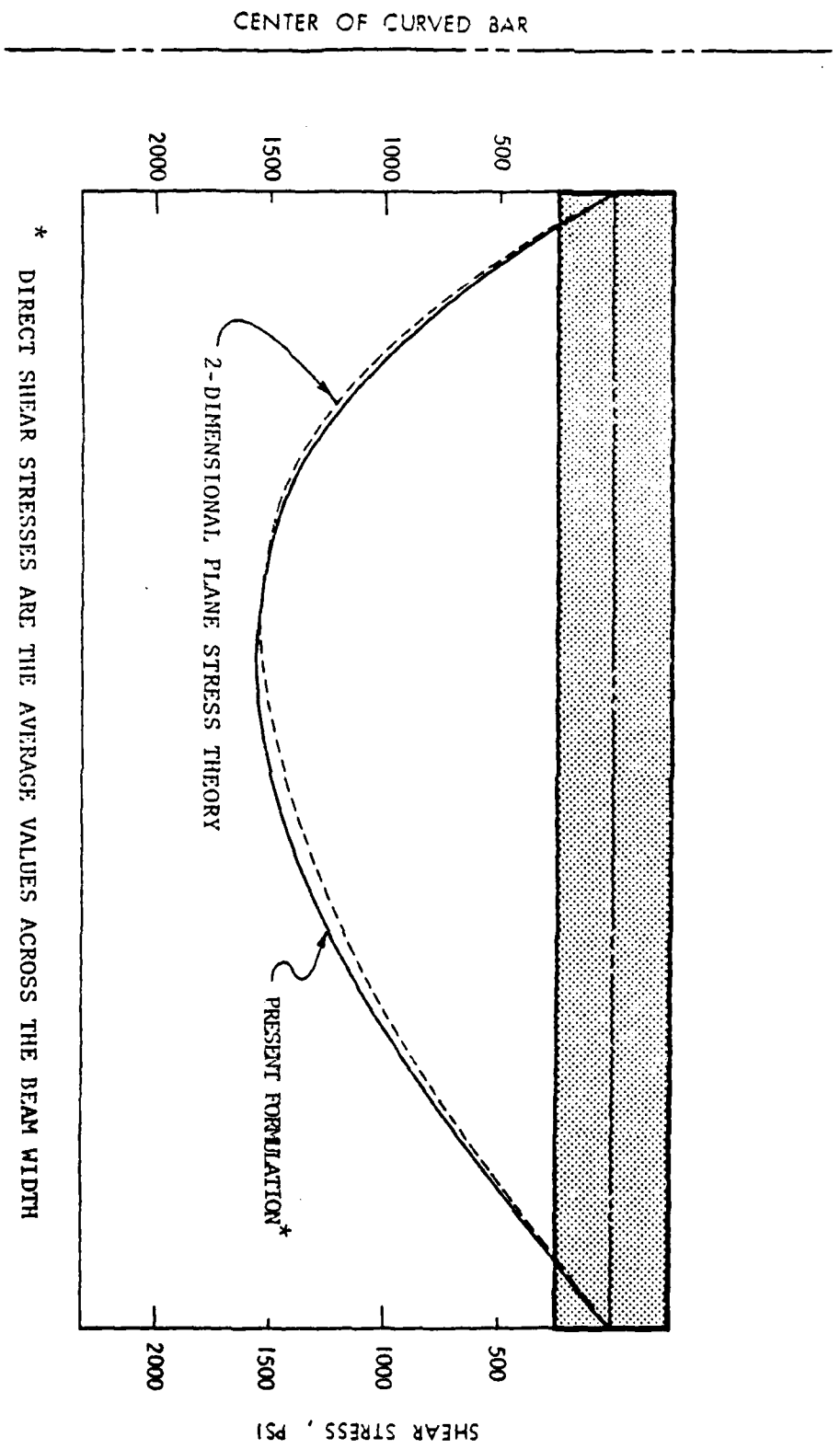

Fig. 4b Direct Shear Stress Distributions Along the Center Line of the Bar of Fig. 2

Note: 1 in. = 0.0254 m; 1 psi = 6.895 kN/m²

CENTER OF CURVED BAR

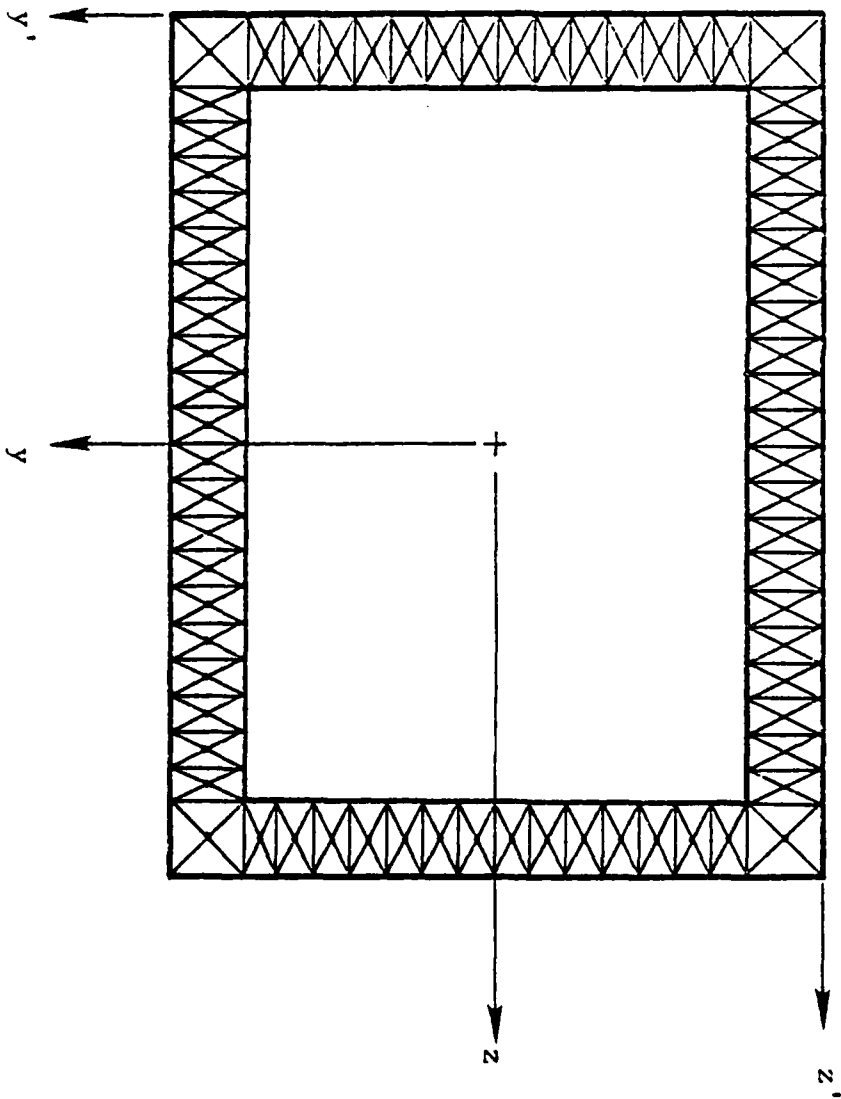

Fig. 5 Finite Element Representation of a Curved Box Section

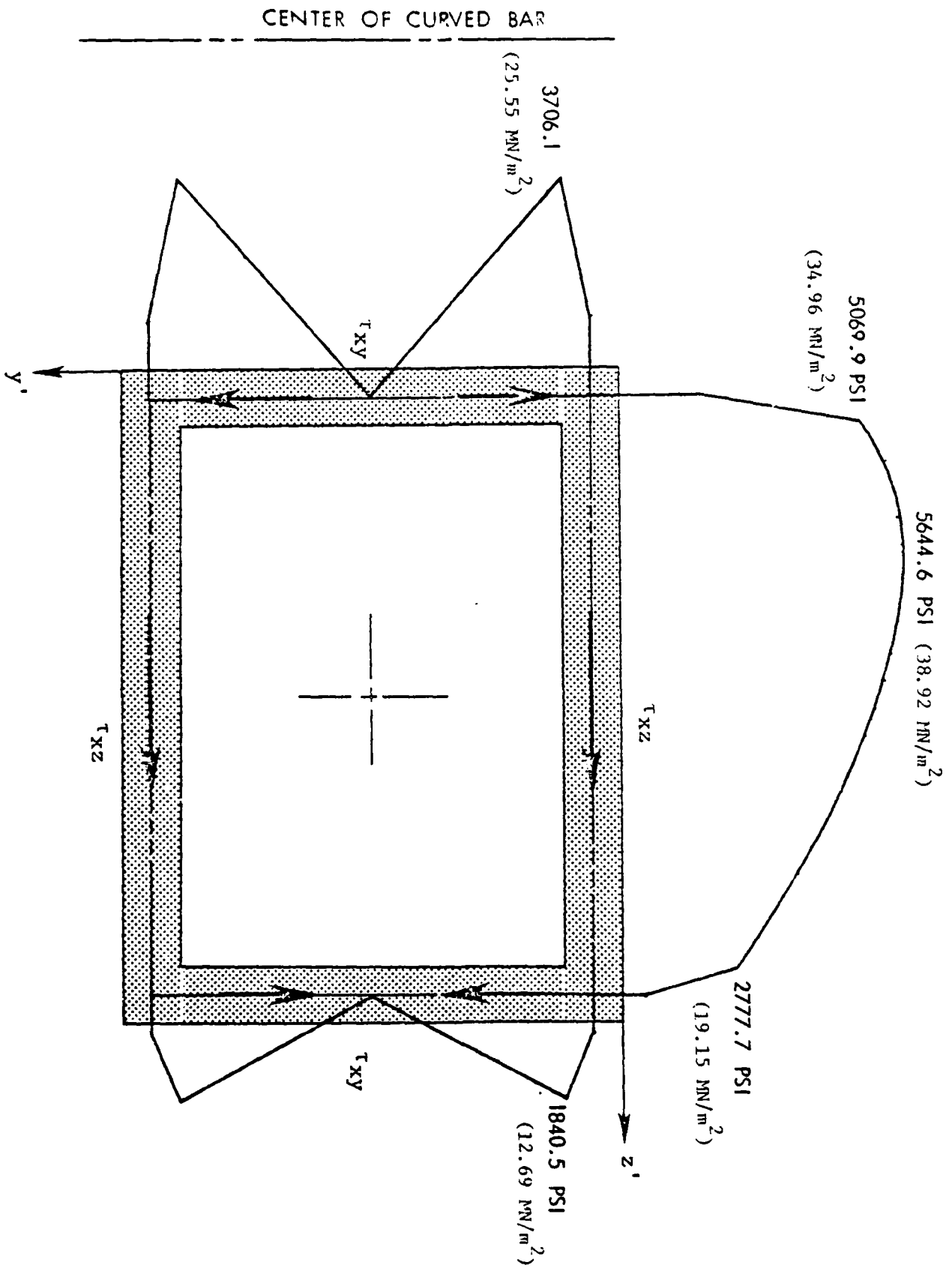

Fig. 6 Direct Shear Stresses on a Curved Box Section

DISTRIBUTION LIST

No. of Copies

1 - 6	Office of Naval Research 800 N. Quincy Street Arlington, Virginia 22217
1	Dr. Nick Perrone Office of Naval Research 800 N. Quincy Street Arlington, Virginia 22217
1	ONRRR 2110 G. Street, N.W. Washington, D.C., 20037 Attn: C. Richard Main
1	I. A. Fischer
1	W. D. Pilkey
1	C. Thasanatorn
1	L. S. Fletcher
2	E. H. Pancake Science/Technology Information Center Clark Hall
1	RLES Files
1	Each entry in ONR Structural Mechanics Contract Research Program Distribution List

DATE
ILME