

AD-A119 717

NAVY PERSONNEL RESEARCH AND DEVELOPMENT CENTER SAN D--ETC F/G 5/9

THE ENLISTED SURVIVAL TRACKING FILE (STF): A REVISION.(U)

SEP 82 K W GAY, J I BORACK

NPRDC-TN-82-27

UNCLASSIFIED

NL

1 of 2

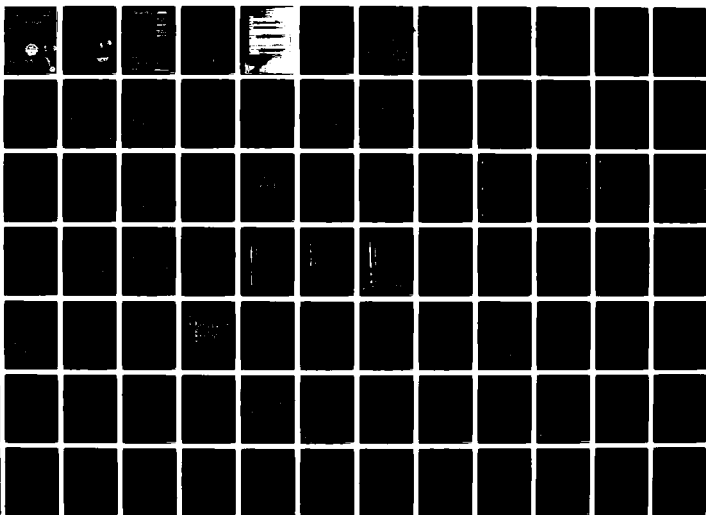

12

NPRDC TN 82-27

SEPTEMBER 1982

AD A119717

THE ENLISTED SURVIVAL TRACKING
FILE (STF): A REVISION



DTIC
ELECTE
SEP 28 1982
S D H

DTIC FILE COPY

NAVY PERSONNEL RESEARCH
AND
DEVELOPMENT CENTER
San Diego, California 92152

DISTRIBUTION STATEMENT I
Approved for public release
Distribution Unlimited

82 09 28 011



**THE ENLISTED SURVIVAL TRACKING FILE (STF):
A REVISION**

**Kenneth W. Gay
Naval Military Personnel Command**

**Jules I. Borack
Navy Personnel Research and Development Center**

**Reviewed by
Joe Silverman**

**DTIC
ELECTE
SEP 28 1982
S D
H**

**Released by
James F. Kelly, Jr.
Commanding Officer**

**DISTRIBUTION STATEMENT A
Approved for public release
Distribution Unlimited**

**Navy Personnel Research and Development Center
San Diego, California 92152**

UNCLASSIFIED

SECURITY CLASSIFICATION OF THIS PAGE (When Data Entered)

REPORT DOCUMENTATION PAGE		READ INSTRUCTIONS BEFORE COMPLETING FORM
1. REPORT NUMBER NPRDC TN 82-27	2. GOVT ACCESSION NO. AD-A119 717	3. RECIPIENT'S CATALOG NUMBER
4. TITLE (and Subtitle) THE ENLISTED SURVIVAL TRACKING FILE (STF): A REVISION	5. TYPE OF REPORT & PERIOD COVERED Final Report	
	6. PERFORMING ORG. REPORT NUMBER 15-82-16	
7. AUTHOR(s) Kenneth W. Gay, Naval Military Personnel Command Jules I. Borack Navy Personnel Research and Development Center	8. CONTRACT OR GRANT NUMBER(s)	
	9. PERFORMING ORGANIZATION NAME AND ADDRESS Navy Personnel Research and Development Center San Diego, California 92152	
10. PROGRAM ELEMENT, PROJECT, TASK AREA & WORK UNIT NUMBERS ZF63-521-001-010	11. CONTROLLING OFFICE NAME AND ADDRESS Navy Personnel Research and Development Center San Diego, California 92152	
	12. REPORT DATE September 1982	
13. MONITORING AGENCY NAME & ADDRESS (if different from Controlling Office)	13. NUMBER OF PAGES 97	
	14. SECURITY CLASS. (of this report) UNCLASSIFIED	
15. DISTRIBUTION STATEMENT (of this Report) Approved for public release; distribution unlimited.		
16. DISTRIBUTION STATEMENT (of the abstract entered in Block 20, if different from Report)		
17. SUPPLEMENTARY NOTES		
18. KEY WORDS (Continue on reverse side if necessary and identify by block number) Manpower requirements Manpower supply Personnel policies Decision making		
19. ABSTRACT (Continue on reverse side if necessary and identify by block number) This report supersedes NPRDC Technical Note 81-11 of April 1981. It provides an update of the Enlisted Survival Tracking File (STF), a data base that permits analysis of the longitudinal behavior of individuals or groups of individuals. STF has been used to forecast personnel losses.		

DD FORM 1 JAN 73 1473

EDITION OF 1 NOV 65 IS OBSOLETE
S/N 0102-LF-014-6601

UNCLASSIFIED
SECURITY CLASSIFICATION OF THIS PAGE (When Data Entered)

FOREWORD

The work described in this report was conducted within task area ZF63-521-001-010 (Manpower Management Decision Technology), work unit 3.12 (Cohort Continuance Models), and supports work unit 3.16 (Accession Planning Models). The overall objective of the task area is to develop techniques to improve the Navy's managerial decision-making capabilities. The objective of work unit 3.12 is to develop techniques to relate longitudinal plans and policies directly with personnel data relating to specific points in time; and of work unit 3.16, to develop methods to analyze tradeoffs between enlisted manpower requirements, personnel policies, and available enlisted manpower supply.

This report supersedes NPRDC Technical Note 81-11 of April 1981. It provides an update of the Enlisted Survival Tracking File (STF), a data base that permits analysis of the longitudinal behavior of individuals or groups of individuals (e.g., cohorts). This data base has been used by OP-135 in forecasting personnel losses. In addition, it is a principal source of information for the Structured Accession Planning System (STRAP), which has been developed for use by OP-120 and DCNO (MPT).

JAMES F. KELLY, JR
Commanding Officer

JAMES W. TWEEDDALE
Technical Director

Accession For	
NTIS GRA&I	<input checked="" type="checkbox"/>
DTIC TAB	<input type="checkbox"/>
Unannounced	<input type="checkbox"/>
Justification	
By _____	
Distribution/	
Availability Codes	
Dist	Avail and/or Special





CONTENTS

	Page
INTRODUCTION	1
Problem	1
Objective	1
APPROACH	1
STF DESCRIPTION	1
Overview	1
STF-L File	2
STF-B File	2
Interpretation of STF Record Sequences	5
STF Applications	7
FUTURE DEVELOPMENTS	7
APPENDIX A--STF-L DATA ELEMENTS AND CODING STRUCTURES	A-0
APPENDIX B--STF-B DATA ELEMENTS AND CODING STRUCTURES.	B-0
APPENDIX C--STF UPDATE PROCESSING	C-0
DISTRIBUTION LIST	

LIST OF FIGURES

1. STF-L Record Format	3
2. STF-L position correspondence with audit/trail and EMR files.	4
3. STF-B Record Format, showing length of data elements and positions where they start on the record	5
4. A sequence of STF-L records for individuals with fictitious social security numbers 1111111111 and 2222222222	6

INTRODUCTION

Problem

The development of comprehensive Navy personnel management systems requires longitudinal analysis of enlisted personnel behavior. Such analysis requires a data base containing a chronological record of individual behavior.

Objective

The objective of the effort described herein was to develop the Enlisted Survival Tracking File (STF), a readily accessible, comprehensive source of enlisted longitudinal personnel data.

APPROACH

Development was initiated in 1975 by the Bureau of Naval Personnel. Specifically, Pers 5212 (Enlisted Programs Branch) and Pers 2120 (Enlisted Strength and Advancement Planning) requested Pers 35-b (Operations Research) to create an ongoing "survival rate" report to serve the needs of both organizations.

Since NAVPERSRANDCEN required the use of an enlisted longitudinal data base to facilitate its cohort continuance modeling effort, it collaborated with Pers 35-b (now NMPC-164) in 1977 to develop the STF. This data base was to be consistent with official Navy data bases (such as the Enlisted Master Record (EMR) File), and it was intended to (1) serve the needs of Navy enlisted loss and strength planners (OP-133), (2) satisfy the design requirements of new manpower programming systems (OP-120/DSS), and (3) provide data necessary for the analysis of enlisted cohort continuance behavior.

STF DESCRIPTION

Overview

The STF consists of two separate collections of records--a longitudinal file (STF-L) and a biographical file (STF-B). STF-L consists of sequences of fixed-length records that represent the status of each individual at quarterly intervals. STF-B consists of one fixed-length record per individual containing selected biographical data. The data used to construct these files are derived from the end-of-quarter EMR file and the quarterly audit/trail file. These files are routinely prepared by NMPC-163 and are documented in the Navy Manpower and Personnel Management Information System (MAPMIS) manual.

Both STF files contain records commencing with the end of the fourth quarter of FY 1977. Therefore, for all individuals accessed after the fourth quarter of FY77, the STF contains a complete longitudinal description of their enlistment history. Appendices A and B provide data elements and coding directives for the STF-L and STF-B files respectively. The process involved in updating the STF is described in Appendix C.

STF-L File

The STF-L file consists of fixed length, 120-character records with the format shown in Figure 1 (fixed-block with a block size of 12,000). The correspondence between STF data elements and their associated positions on the Navy audit/trail and EMR files is shown in Figure 2.

All records for each individual occur consecutively in chronological order. Each record represents the status of an individual (with respect to certain variables) as of the end of a specific quarter. Such a record exists for every quarter during which the individual appeared in active duty status on the EMR. Moreover, whenever the status of an individual (with respect to these variables) does not change from quarter to quarter, a counter is incremented to indicate that the contents of the record relate to more than one quarter.

The first data element in each STF-L record is the social security number, a nine-position number used to identify the individual. The next is a five-position number--10-14--that indicates the "as-of" date for the information contained in that record.

Positions 10-11 give the last 2 digits of the fiscal year; position 12, the specific quarter within the fiscal year for which the data are pertinent; and positions 13-14, the number of consecutive quarters for which the data are pertinent. Thus, the sequence "78301" appearing in positions 10-14 would indicate that the data in this record pertain to the end of the third quarter of FY78 (i.e., end June 1978) and that the data pertain only to that quarter. Similarly, the sequence "78304" would indicate that the data pertain to the end of the third quarter of FY78 (i.e., end June 1978) and to the end of the following three quarters (i.e., end Sept. 1978, end Dec. 1978, and end Mar. 1979).

As shown in Figure 1, Positions 111-120 of a given record are used to indicate Loss Date of Occurrence (111-114), Loss Code Navy (115-117), and Loss Code DoD (118-120). These positions are filled in if the individual left active duty status during the fiscal year and quarter shown in positions 10-12 and did not return to active duty prior to the end of that quarter. When positions 111-120 are filled in, positions 13-14 (quarter count) always contain "01." The sequence "951" appearing in positions 115-120 of a given record would indicate the individual entered desertion status during the fiscal year and quarter shown in positions 10-12 and remained in desertion status as of the end of that quarter.

STF-B File

The STF-B file consists of fixed-length, 120-character records with the format shown in Figure 3 (fixed-block, with block size of 32,400). This file consists of one record per individual. Each record contains selected biographical data obtained from the individual's most recent end-of-quarter EMR file, except in the case of home of record (positions 10-11), which is obtained from the earliest end-of-quarter EMR file monitored for the individual.

<u>Data Element</u>	<u>Length</u>	<u>Start</u>
Social Security Number	9	1
As-of Date Fiscal Year	2	10
As-of Date Quarter	1	12
As-of Date Count	2	13
Strength Indicator	1	15
Sex	1	16
Race	1	17
Ethnic Group	1	18
Date of Birth	4	19
AFQT	2	23
Education Years	2	25
Education Certification	1	27
A-School Indicator*	1	28
Dependency-Primary	1	29
Term of Enlistment	1	30
Type of Enlistment	2	31
Term Status	1	33
Number of Enlistments	1	34
Type of Acquisition	2	35
Type of Program*	1	37
Rate/Special Program Code	5	38
Branch/Class	2	43
RADO Months	3	45
Enlisted Designator	1	48
Present Rate Code	4	49
Present Pay Grade	1	53
PNEC	4	54
SNEC	4	58
ADSD	4	62
PEBD	4	66
CED	4	70
CADD	4	74
EAOS	4	78
Soft EAOS	4	82
EAOS Change Indicator*	1	86
Onboard Actual UIC	5	87
Onboard ACC	3	92
Onboard Sea/Shore Code	1	95
Onboard Transfer Date	4	96
Past Actual UIC	5	100
SRB Received Indicator*	1	105
SRB Zone	1	106
SRB Skill Indicator	1	107
SRB Award Level	1	108
RQC	2	109
Loss Date of Occurrence	4	111
Loss Code Navy	3	115
Loss Code DoD	3	118
LRECL = 120 BLKSIZE = 32400 RECFM = FB		
Sort Sequence: SSN (Major) As-of Date (Minor)		

*Computed STF data elements.

Figure 1. STF-L Record Format

<u>Data Element</u>	<u>Length</u>	<u>Start</u>	<u>Audit/ Trail</u>	<u>EMR</u>
Social Security Number	9	1	1	1
As-of Date Fiscal Year	2	10	-	-
As-of Date Quarter	1	12	-	-
As-of Date Count	2	13	-	-
Strength Indicator	1	15	37,38	44,45
Sex	1	16	49	71
Race	1	17	50	72
Ethnic Group	1	18	51	73
Date of Birth	4	19	43	65
AFQT	2	23	173	2338
Education Years	2	25	169	331
Education Certification	1	27	320	333
A-School Indicator*	1	28	-	-
Dependency-Primary	1	29	55	90
Term of Enlistment	1	30	160	310
Type of Enlistment	2	31	158	308
Term Status	1	33	334	253
Number of Enlistments	1	34	161	311
Type of Acquisition	2	35	252	2120
Type of Program*	1	37	-	-
Rate/Special Program Code	5	38	234	2124
Branch/Class	2	43	120	262
RADO Months	3	45	155	305
Enlisted Designator	1	48	104	234
Present Rate Code	4	49	56	97
Present Pay Grade	1	53	60	101
PNEC	4	54	86	150
SNEC	4	58	90	158
ADSD	4	62	122	264
PEBD	4	66	134	282
CED	4	70	128	276
CADD	4	74	128	270
EAOS	4	78	140	288
Soft EAOS	4	82	-	256
EAOS Change Indicator*	1	86	-	-
Onboard Actual UIC	5	87	181	370
Onboard ACC	3	92	204	438
Onboard Sea/Shore Code	1	95	189	394
Onboard Transfer Date	4	96	-	456
Past Actual UIC	5	100	-	505
SRB Received Indicator*	1	105	-	-
SRB Zone	1	106	-	2340
SRB Skill Indicator	1	107	-	2353
SRB Award Level	1	108	-	2354
RQC	2	109	108	237
Loss Date of Occurrence	4	111	272	612
Loss Code Navy	3	115	278	618
Loss Code DoD	3	118	208	625

*Computed STF data elements.

Figure 2. STF-L position correspondence with audit/trail and EMR files.

<u>Data Element</u>	<u>Length</u>	<u>Start</u>
Social Security No.	9	1
Home of Record	2	10
DoD-AFEES	3	12
SCREEN	3	15
Mental Apt Test ID	2	18
Mental Apt Test Results	26	20
School History (5x8)	40	46
Completion Date (4)		
Course Code (4)		
School History		
Student action (5x2)	10	86
School type (5x1)*	5	96
School course code TDPG-1	4	101
School course code TDPG-2	4	105
School course code TDPG-3	4	109
School type TDPG (3x1)*	3	113
School course code avail	4	116
School type avail*	1	120

LRECL = 120 BLKSIZE = 32,400 RECFM = FB
Sort Sequence: SSN (Major)
* Computed STF Data Elements

Figure 3. STF-B Record Format, showing length of data elements and positions where they start on the record.

Interpretation of STF Record Sequences

Figure 4 presents a sequence of records from the STF-L file updated through the end of the fourth quarter of FY79 (i.e., end Sept. 1979). The sequence contains the historical records of two individuals identified by their SSNs (111111111 and 222222222). Note that the file contains three records for each individual.

	1	2	3	4	5	6	7	8	9	10	11	12
1.....	0.....	0.....	0.....	0.....	0.....	0.....	0.....	0.....	0.....	0.....	0.....	0.....
11111111177403FMCY570369101104111117				11	730050000	740674067406000078067806	033411004	622540				
11111111178301BMCY570369101 04111117				11	7300400000000740874077406000078087808	0334110947809411040	7806951					
11111111179101BMCY570369101104931117				11	7300600000000741074097406000078107810	3274639017811317460	1 7811942LHK					
2222222279201FMCY5906671326 4011111				11	36005	790379037903000083038303	311553401	0				
2222222279301FMCY5906671223 4011111				11	360059710	790379037903000083038303	305653421	311550				
2222222279401FMCY5906671221 4011111				11	2360059710	79037903790300008303850	311573421	30560				

Figure 4. A sequence of STF-L records for individuals with fictitious social security numbers 11111111 and 22222222.

The records listed in Figure 4 are described below:

1. SSN = 11111111

a. Positions 10-12 of the first record (774) indicate that this individual's history has been tracked only from the end of the fourth quarter of FY77 (his active duty service date (ADSD), appearing in positions 62-65, is June 1974 (7406)). Positions 13-14 (03) indicate that the data in this record relate to the end of the first quarter of FY 1978 and the end of the second quarter of FY 1978, as well as the end of the fourth quarter of FY 1977.

b. The next record for this individual shows his status at the end of the third quarter of FY 1978. Positions 111-120 (7806951) of this record show that he was in desertion status at that time and had been declared a deserter in June 1978. Since no record for this individual appears at the end of the fourth quarter of FY 1978, it appears that he was still in desertion status at that time and had not returned to active duty status at any time during the quarter.

c. The third and last record for this individual shows that, at the end of the first quarter of FY 1979, he had left the Navy. Positions 111-120 (7811942 LHK) indicate that his separation occurred in November 1978 with Navy loss code 942 and DoD loss code (SPD code) LHK. No subsequent records appear for this individual, indicating that he did not return to active duty.

2. SSN = 22222222

a. Positions 10-12 of the first record (792) for this individual indicate that his history has been tracked beginning at the end of the second quarter of FY79. Since positions 62-65 (7903) show that his ADSD is March 1979, it is clear that the file contains his entire enlistment history. Positions 13-14 (01) indicate that the data in this record relate only to this quarter.

b. The second record shows that some data fields have been changed for this individual (e.g., PNEC (positions 54-57), soft EAOS (positions 82-85), onboard UIC (positions 87-91), onboard ACC (positions 92-94), and past UIC (positions 100-104)). Similarly, each subsequent end-of-quarter record shows changes in one or more data fields.

c. Positions 10-12 (794) of the third record for this individual indicate that he was still in active duty status at the end of the fourth quarter of FY79.

STF Applications

The STF is currently serving as the principal data source for a Standard Report Generator (SRG), the STRAP Enlisted Predictor (STEP), and the Enlisted Loss Information System (ELIS).

a. SRG provides summary statistical data for any subset of Navy personnel definable in terms of STF variables. "Cohorts" may be defined in terms of values of STF variables at various stages of an individual's enlisted history. The report generator displays the number of individuals in this cohort who entered the Navy in each fiscal year and quarter, who were onboard at the end of each fiscal year and quarter, and who were lost to the Navy (disaggregated by reason) during each fiscal year and quarter.

b. STEP serves as a module within the Navy's Structured Accession Planning (STRAP) system.¹ STEP provides the system with historically based rates and counts that are used in projecting future personnel flows. These flows include attrition, reenlistment, advancements through the lower three pay grades, extensions, and others.

c. ELIS is a computerized information system that enables a user to obtain historical data and projections of losses and related personnel flows. Further information on this system can be obtained from NMPC-164 (Decision Support Systems).

FUTURE DEVELOPMENTS

It is anticipated that data from earlier years (i.e., prior to September 1977) will be added to the STF to enhance its utility. Additionally, data elements derived from the candidate data base (CANDAB) may be added to the STF to facilitate studies of advancement examination test-takers. Finally, consideration will be given to the benefits of creating additional data elements.

¹Borack, J. L., & Gay, K. W. The STRAP Enlisted Predictor (STEP) (NPRDC Tech. Rep. 81-16). San Diego: Navy Personnel Research and Development Center, July 1981. (AD-A102 910)

APPENDIX A
STF-L DATA ELEMENTS AND CODING STRUCTURES

Table 1.

SURVIVAL TRACKING FILE

STF-L RECORD FORMAT

<u>DATA ELEMENT</u>	<u>Length</u>	<u>Start</u>
Social Security No.	9	1
As-Of Date Fiscal Yr.	2	10
Quarter	1	12
Count	2	13
Strength Indicator	1	15
Sex	1	16
Race	1	17
Ethnic Group	1	18
Date of Birth	4	19
AFQT	2	23
Education Years	2	25
Education Certification	1	27
A-School Indicator *	1	28
Dependency-Primary	1	29
Term Enlistment	1	30
Type Enlistment	2	31
Term Status	1	33
Number of Enlistments	1	34
Type of Acquisition	2	35
Type of Program *	1	37
Rate/Special Prog Code	5	38
Branch/Class	2	43
RADO Mos	3	45
Enlisted Designator	1	48
Present Rate Code	4	49
Present Pay Grade	1	53
PNEC	4	54
SNEC	4	58
ADSD	4	62
PEBD	4	66
CED	4	70
CADD	4	74
EAOS	4	78
Soft EAOS	4	82
EAOS Change Indicator*	1	86
Onboard Actual UIC	5	87
Onboard ACC	3	92
Onboard Sea/Shore Code	1	95
Onboard Transfer Date	4	96
Past Actual UIC	5	100
SRB Received Indicator *	1	105
Zone	1	106
Skill Indicator	1	107
Award Level	1	108
RQC	2	109
Loss Date of Occurrence	4	111
Loss Code Navy	3	115
Loss Code DoD	3	118
LRECL = 120 BLKSIZE = 3200 RECFM=FB		
Sort Sequence: SSN (Major) As-Of Date (Minor)		

Table 2

STF-L
POSITION CORRESPONDENCE WITH AUDIT/TRAIL & EMR FILES

<u>DATA ELEMENT</u>	<u>Length</u>	<u>Start</u>	<u>Audit/ Trail</u>	<u>EMR</u>
Social Security No.	9	1	1	1
As-Of Date Fiscal Yr.	2	10	-	-
Quarter	1	12	-	-
Count	2	13	-	-
Strength Indicator	1	15	37,38	44,45
Sex	1	16	49	71
Race	1	17	50	72
Ethnic Group	1	18	51	73
Date of Birth	4	19	43	65
AFQT	2	23	173	2338
Education Years	2	25	169	331
Education Certification	1	27	320	333
A-School Indicator *	1	28	-	-
Dependency-Primary	1	29	55	90
Term Enlistment	1	30	160	310
Type Enlistment	2	31	158	308
Term Status	1	33	334	253
Number of Enlistments	1	34	161	311
Type of Acquisition	2	35	252	2120
Type of Program *	1	37	-	-
Rate/Special Prog Code	5	38	234	2124
Branch/Class	2	43	120	262
RADO Mos	3	45	155	305
Enlisted Designator	1	48	104	234
Present Rate Code	4	49	56	97
Present Pay Grade	1	53	60	101
PNEC	4	54	86	150
SNEC	4	58	90	158
ADSD	4	62	122	264
PEBD	4	66	134	282
CED	4	70	128	276
CADD	4	74	128	270
EAOS	4	78	140	288
Soft EAOS	4	82	-	256
EAOS Change Indicator*	1	86	-	-
Onboard Actual UIC	5	87	181	370
Onboard ACC	3	92	204	438
Onboard Sea/Shore Code	1	95	189	394
Onboard Transfer Date	4	96	-	456
Past Actual UIC	5	100	-	505
SRB Received Indicator *	1	105	-	-
Zone	1	106	-	2340
Skill Indicator	1	107	-	2353
Award Level	1	108	-	2354
RQC	2	109	108	237
Loss Date of Occurrence	4	111	272	612
Loss Code Navy	3	115	278	618
Loss Code DoD	3	118	208	625

* Computed STF data elements

Chapter II
Part A
Section 1

Enlisted Data Element Dictionary

SOCIAL SECURITY NUMBERS (SSN)

1. DEFINITION. A 9-position number used to identify an individual. SSN is the major control, used with the first five characters of name, for locating an individual within the NAFMIS system and no two members may legally be identified by the same number. A member will be specifically identified in all records, files, reports, and correspondence by his SSN.

2. REFERENCES.

- a. BUPERS Instruction 1070.20
- b. BUPERS Manual, NAVPERS 15791
- c. Navy Recruiting Manual, COMNAVCEUITCOMINST 1130.8
- d. PAYPERS Manual, Part 9, Chapter 6, NAVSO F-3050
- e. Pers-38 Internal Procedures

3. CODE STRUCTURE. See APPENDIX A.17.

4. APPLICABLE TRANSACTIONS.

Change
Code

Description

1xx	Navy-strength Gain
2xx	Activity-strength Gain
344	SSN Change
CAC	CACHE Gains
QC0	Availability

AS-OF DATE

1. **Definition:** A 5-position number used to indicate the As-Of Date of the data contained in the record. The As-Of Date is based on the date of the update processing.

2. **Code Structure:**

FY (STF 10-11) Fiscal year

Quarter (STF 12) Quarter of fiscal year

Count (STF 13-14) Number of quarters data in record remains unchanged

STRENGTH INDICATOR

1. **DEFINITION:** A-1 Position Alphanumeric Field Derived from the Strength Control Indicator (SC-IND)

(EMR Positions 44-45; Audit/Trail Positions 37-38)

2. **CODE STRUCTURE:**

F - Active Strength Records -
SC-IND (EMR 44-45) - XF

H - Loss/Hold
SC-IND (EMR 44-45) - HX

D - Deserter
SC-IND (EMR 44-45) - DX

A - Loss/Hold Supported by an Availability -
SC-IND (EMR 44-45) - AX

R - Deserter Supported by an Availability -
SC-IND (EMR 44-45) - RX

Chapter II
Part A
Section 1

Enlisted Data Element Dictionary

STRENGTH CONTROL INDICATOR (SCINE)

1. DEFINITION. A 5-position alphanumeric field which represents a member's current strength status in the Enlisted Master Record. Field consists of:

- a. LOSS/HOLD status (position 1)
- b. Flexwriter/Enlisted Service Record (position 2)
- c. 1xx/2xx Gains (position 3)
- d. (position 4 reserved for future use)
- e. Availability Gain (position 5)

2. REFERENCES.

- a. Internal requirements of Pers-35
- b. NAVPERS Manual, Part 9, Chapter 6, NAVSO F-3050
- c. Navy Recruiting Manual, COMNAVCRUITCOMINST 1130.8

3. CODE STRUCTURE.

<u>Code</u>	<u>Description</u>
XPXXX	Active Strength record
XEXXX	SCAT/ESR record with data errors
HXXXX	EMR Loss/Hold recorded
DXXXX	EMR Deserter record
AXXXX	EMR Record in a Loss/Hold status supported by an availability
XXXXA	EMR Record created by an availability
XXXXC	EMR Record created by COMPASS Prospective Gains and Avails
RXXXX	EMR Record in a deserter status with a subsequent Avail reported
XX1XX	Created by 194/195/18x change codes
XX2XX	EMR Record established by an Activity Gain (2xx)

Chapter II
Part A
Section 1

Enlisted Data Element Dictionary

SEX (SEX)

1. **DEFINITION.** A 1-position alphabetic field assigned to distinguish between male and female members.

2. **REFERENCES.**

- a. Navy Recruiting Manual, COMNAVCRUITCONINST 1130.8
- b. PAYPERS Manual, Part 9, Chapter 6, NAVSO P-3050

3. **CODE STRUCTURE.**

<u>Code</u>	<u>Description</u>
F	Female
M	Male
Z	Not reported

4. **APPLICABLE TRANSACTIONS.**

<u>Change Code</u>	<u>Description</u>
1xx	Navy-strength gain
1FL/ESP	SCAT Gain/Enlisted Service Record Gain
18x	Transactions from OCARS (see Remarks)
194/195	INVOL Recalled/VOL Recalled to Active Duty
327	Change/Correct SEX

Chapter II
Part A
Section 1

Enlisted Data Element Dictionary

RACE (RACE)

1. DEFINITION. A 1-position alphabetic field which indicates a division of mankind possessing common traits that are transmissible by descendency, sufficient to characterize it as a distinct human type.

2. REFERENCES.

- a. Navy Recruiting Manual, CONNAVCRUITCONINST 1130.8
- b. DOD Instruction 1336.5 (NOTAL)
- c. BUPERS Manual, NAVPERS 15791

3. CODE STRUCTURE.

<u>Code</u>	<u>Abbr</u>	<u>Description</u>
C	CAU	Caucasian
N	NEG	Negroid
X	OTH	Other
Z	UNK	Unknown

4. APPLICABLE TRANSACTIONS.

<u>Change Code</u>	<u>Description</u>
1PL	SCAT Navy-strength gain
ESR	Enlisted Service Record gain
352	Race Code

Chapter II
Part A
Section 1

Enlisted Data Element Dictionary

ETHNIC GROUP (ETHNIC)

1. **DEFINITION.** A 1-position field which identifies segments of the population that possess common characteristics and a cultural heritage significantly different from that of the general population.

2. **REFERENCES.**

- a. PAYPERS Manual, Part 9, Chapter 6, NAVSO P-3050
- b. BUPERS Manual, NAVPERS 15791
- c. Manual for Standard Data Elements, DOD 5000.12

3. **CODE STRUCTURE.** See Appendix A.15.

4. **APPLICABLE TRANSACTIONS.**

<u>Change Code</u>	<u>Description</u>
E77	Change ETHNIC GROUP
1PL	SCAT Gain
ESR	Enlisted Service Record Gain

5. **UPDATE METHODS.**

<u>Source</u>	<u>Mode</u>
Activity	a. Enlistment Contract, DD FORM 4
	b. Personnel Diary, NAVPERS 1075/75
Census Match BUPERS	a. Data Exchange Tape to EPNAC
	a. Cards from research (TAC E77)
Pers-38	a. Cards from research (TAC E77)
EPNAC	a. Enlisted Change Tape

Chapter II
Appendix A

Table 15 -- ETHNIC GROUP

<u>Ethnic Group</u>	<u>Abbreviation</u>	<u>Code</u>	<u>Description</u>
SPANISH DESCENT	SPAN-DCNT	1	Includes all personnel of Spanish extraction, except when delineated separately.
AMERICAN INDIAN	AMER-IND	2	Includes all personnel of American Indian extraction, except when delineated separately.
ASIAN AMERICAN	ASIAN-AMER	3	Includes all personnel of Asian/Pacific derivation, except when delineated separately.
PUERTO-RICAN	PR	4	
FILIPINO	FILIPINO	5	
MEXICAN-AMERICAN	MEXICAN	6	Includes 'CHICANO'
ESKIMO	ESKIMO	7	Does not include ALEUT
ALEUT	ALEUT	8	
CUBAN-AMERICAN	CUBAN	9	
CHINESE	CHINESE	G	
JAPANESE	JAPANESE	J	
KOREAN	KOREAN	K	
OTHER		X	A member of an ethnic group not included above
NONE	NONE	Y	A member considers oneself to be of the 'general population'
UNKNOWN	UNKN	Z	Data unavailable

Chapter II
Part A
Section 1

Enlisted Data Element Dictionary

DATE OF BIRTH (BIRTH)

1. DEFINITION. A 6-position numeric field (YRMODA) which indicates the birth date of the member as recorded on his Enlistment Contract.

2. REFERENCES.

- a. PAYPERS Manual, NAVSO P-3050
- b. Navy Recruiting Manual, COMNAVCRUITCOMINST 1130.8
- c. BUPERS Manual, NAVPERS 15791

3. CODE STRUCTURE.

<u>Code</u>	<u>Description</u>
*****	DOB reported erroneously; must be corrected by Pers-3522
(YRMODA)	Year (2-pos.), Month (2-pos.), Day (2-pos.)

4. APPLICABLE TRANSACTIONS.

<u>Change Code</u>	<u>Description</u>
1FL	Navy strength gain
ESR	Enlisted Service Record gain - see Remark c.
C32	Change DOB (OCR)

Enlisted Data Element Dictionary

ARMED FORCES QUALIFICATION TEST SCORE (AFQTSORE)

1. DEFINITION. A 2-position numeric field which indicates the score attained on the AFQT by selected groups of personnel as set forth in the RECRUITING MANUAL. For female members, this field will contain Armed Forces Women's Selection Test Scores.

2. REFERENCES.

- a. Navy Recruiting Manual, COMNAVCEUITCCMINST 1130.8
- b. DOE Instruction 1145.3

3. CCDZ STRUCTURE.

<u>Code</u>	<u>Description</u>
(blank)	Not reported
00	AFQT not required to be reported by AFES
01-98	Attained score of 01 through 98 (2 positions)
99	Attained score of 99 or greater

4. APPLICABLE TRANSACTIONS.

<u>Change Code</u>	<u>Description</u>
B29	Test Scores (See REMARKS)
1FL	SCAT Gain
ESR	Enlisted Service Record Gain to
C70	AFQT Score

5. UPDATE METHODS.

<u>Source</u>	<u>Code</u>
Activity	a. Official correspondence to Pers-55
Pers-352	a. TAC C70 (cards)

Table 07 -- EDUCATION

1. YEARS OF EDUCATION.

<u>Code</u>	<u>Description</u>
01-08	Grammar School grades
09-12	High School grades
13-20	College (1-8 years)

2. EDUCATIONAL CERTIFICATION.

<u>Code</u>	<u>Description</u>
1	None Received
2	High School Diploma
3	High School GED Equivalency
4	Certificate of Completion of an Occupational Program
5	Certificate of Attendance at an Occupational Program
A	1 or 2 years College Level Equivalency
D	Associate Degree Level
G	Professional Nursing Diploma (3-yr hospital school of nursing)
K	Baccalaureate Degree Level and certain first profession degrees (Law, Theology, Optometry, Chiropody, etc.)
N	Masters Degree Level (includes certificates of advanced study and those degrees identified as licentiate)
R	Post-Masters (but below Doctorate)
U	Doctor's Degree Level
W	First-Professional Certificate

NOTE: First-Professional Degrees are the first degrees awarded in:

Architecture
Certified Public Accounting
Chiropody or Podiatry (D.S.C. or POD.D.)
Dentistry (D.D.S. or D.M.D.)
Medicine (M.D.)
Optometry (O.D.)
Osteopathy (D.O.)
Pharmacy
Veterinary Medicine
Law (L.L.B. or J.D.)
Theology (B.D., Rabbi, or other)

Advanced degrees within the above fields are to be coded at the Master's or Doctorate level, as applicable.

3. EDUCATIONAL SOCIETY.

<u>Code</u>	<u>Description</u>
J	PHI BETA KAPPA-member with Baccalaureate Degree
K	PHI BETA KAPPA-member with Masters Degree
L	PHI BETA KAPPA-member with a Doctor's Degree.
M	TAU BETA PI-member with a Baccalaureate Degree.
N	TAU BETA PI-society member with a Master's Degree.
O	TAU BETA PI-society member with a Doctor's Degree.

A-SCHOOL INDICATOR

1. DEFINITION: A 1-position numeric used to indicate the A-school history of an individual. This data element is derived from several different EMR data elements.

2. CODE STRUCTURE:

Code		
1	Attended A-school Graduated	School history course Code (EMR 1166) = A-school course code School-history-student- Action = bb or P1
2	Attended A-school Did not graduate	Same as for 1 except school-history-student- Action (EMR 339) = Other
3	Currently in A-school	Student-availability-course-code (EMR 2280) = A-school course code
4	Slated to attend A-school	Temporary-duty-prospective-gain- 1,2, or 3 course-code (EMR 1616, 1721, 1826) = A-school course code
5	Striker	Present rate code (EMR 97) Not = 3600, 5000, 6000, nor 7800 and present pay grade (EMR 10) = 5,6,7 (E1-3)
6	General Detail	Present rate code (EMR 97) = 3600, 5000, 6000, or 7800
7	None of the above	

MAPMIS SYSTEMS DOCUMENTATION MANUAL, NAVPERS 15,642

Chapter II
Appendix A

Table #2 -- DEPENDENCY

Position 1 = PRI-DEP Position 2 = SEC-DEP	NO SEC DEP	ONE PARENT	TWO PARENTS
No Primary Dependents *For married, no primary dependents, see below.	Ø-Ø	Ø-J	Ø-S
Spouse (no dep children)	1-Ø	1-J	1-S
Spouse & 1 dep child	2-Ø	2-J	2-S
Spouse & 2 dep children	3-Ø	3-J	3-S
Spouse & 3 dep children	4-Ø	4-J	4-S
Spouse & 4 dep children	5-Ø	5-J	5-S
Spouse & 5 dep children	6-Ø	6-J	6-S
Spouse & 6 dep children	7-Ø	7-J	7-S
Spouse & 7 dep children	8-Ø	8-J	8-S
Spouse & 8 or more dep children	9-Ø	9-J	9-S
1 dep child (no spouse)	A-Ø	A-J	A-S
2 dep children	B-Ø	B-J	B-S
3 dep children	C-Ø	C-J	C-S
4 dep children	D-Ø	D-J	D-S
5 dep children	E-Ø	E-J	E-S
6 dep children	F-Ø	F-J	F-S
7 dep children	G-Ø	G-J	G-S
8 or more children	H-Ø	H-J	H-S
*married (no primary dependent)	K-Ø	K-J	K-S

NOTE:

Secondary dependency code structure was revised in April 1973. The following code conversion occurred:

Codes Ø, J, and S remained unchanged.

Codes 1, 2, 3 and 4 were converted to code Ø.

Codes K, L, M and N were converted to code J.

Codes T, U, V and W were converted to S.

3. CODE STRUCTURE. See Appendix A.2

4. APPLICABLE TRANSACTIONS.

<u>Code</u>	<u>Description</u>
1FL	SCAT gain/correction
ESR	Enlisted Service Record gain/correction
336	DEPENDENCY change (PRI/SEC)

5. UPDATE METHODS.

<u>Source</u>	<u>Mode</u>
Activity	a. Dependency Application/Record of Emergency Data, NAVPERS 1070/602 (OCR)
NFC, Cleveland	a. Data Set b. NFC Error Tape
Census Match BUPERS	a. Data Exchange Tape (DET) to EPMAC
Pers-3522	a. Cards from research (TACs 1FL/ESR)
OCARS	a. TACs 336 for members being disenrolled and returned to enlisted status

6. REMARKS.

a. EPMAC corrects its file to reflect the DET DEPENDENCY if Census Match reveals a difference between the EMR and PMR.

b. Always record both PRIMARY and SECONDARY DEPENDENCY Codes, even though one or both may be none.

3. CODE STRUCTURE.

a. TYPE OF ENLISTMENT.

<u>Code</u>	<u>Description</u>
(blank)	Not reported
01	1st enlistment, no prior service, no bonus
03	1st enlistment, USN-S (Inductee), no bonus
10	1st enlistment, prior service, bonus
11	1st enlistment, prior service, no bonus
20	Reenlistment USN-S to USN within 24 hours, bonus
21	Reenlistment USN-S to USN within 24 hours, no bonus
30	Reenlistment within 24 hours, bonus
31	Reenlistment within 24 hours, no bonus
40	Reenlistment within 3 months, bonus
41	Reenlistment within 3 months, no bonus
50	Reenlistment over 3 months, bonus
51	Reenlistment over 3 months, no bonus
81	USN or USNR from Naval Aviation Cadet
82	USN or USNR from Aviation Officer Candidate
83	USN or USNR from Officer Candidate
84	USN or USNR from Naval Academy Midshipman
85	USN or USNR from Naval Reserve Officer Training Corps
86	USN or USNR from Armed Forces Academy other than US Naval Academy
87	Termination of Officer Appointment
88	USN or USNR from Flight Officer
90	Transferred to USNPR/retained on Active Duty
91	Surrender of deserter
93	Delivery of deserter
94	Involuntarily recalled to active duty
95	Voluntarily recalled to active duty
97/98	Error Gain - Appropriate code will be submitted on new Enlisted Service Record Gain (TAG ESB)

b. TERM OF ENLISTMENT.

<u>Code</u>	<u>Description</u>
(blank)	Not reported
0	Not applicable (USNPR, USNRPR, USN-RET, USNR-RET)
1	Minority enlistment
2	Two year enlistment
3	Three year enlistment
4	Four year enlistment
5	Five year enlistment
6	Six year enlistment

Chapter II
Part A
Section 1

Enlisted Data Element Dictionary

TERM STATUS CODE (TERMSTATUS)

1. DEFINITION. A 1-position alphanumeric code which indicates the status of a member (USN only) as affected by a reenlistment or an extension of enlistment which counts as a reenlistment (period equal to or greater than 24 months). This code should be equal to the member's number of enlistments unless member has operative extensions totaling 24 or more months. The code increases by 1 each time a member reenlists or executes OPERATIVE EXPENSIONS totaling 24 or more months.

2. REFERENCES.

- a. PAYPERS Manual, NAVSO P-3058
- b. BUPERS LTR PERS-B2213 HAS/RFP of 14 MAR 1973

3. CODE STRUCTURE.

Code	Description
(blank)	Not reported
0 (zero)	Insular Force, Fleet Reserve, and Retired on Active duty
1-9	First to ninth terms (count for reenlistment)
A-G	Tenth to sixteenth terms (count for reenlistment)
Z	Reserve member on Active Duty

4. APPLICABLE TRANSACTIONS.

Change Code	Description
TSC	TERM STATUS CODE change
1xx	Navy-strength gains (reenlistment only)
300	Discharge/Immediate reenlistment
383	ACDUOBLI OPEX (USN)

C. NUMBER OF ENLISTMENTS IN CURRENT BRANCH AND CLASS OF SERVICE.

<u>Code</u>	<u>Description</u>
(blank)	Not reported
0	Special-Nationals, Fleet Reserve, Retired
1	1st enlistment in current BR/CI
2	2nd enlistment in current BR/CI
3	3rd enlistment in current BR/CI
4	4th enlistment in current BR/CI
5	5th enlistment in current BR/CI
6	6th enlistment in current BR/CI
7	7th enlistment in current BR/CI
8	8th enlistment in current BR/CI
9	9th enlistment in current BR/CI
A	10th enlistment in current BR/CI
B	11th enlistment in current BR/CI
C	12th enlistment in current BR/CI
D	13th enlistment in current BR/CI
E	14th enlistment in current BR/CI
F	15th enlistment in current BR/CI

Chapter II
Part A
Section 1

Enlisted Data Element Dictionary

TYPE OF ACQUISITION (ACTYPEAQN)

1. DEFINITION. A 2-position numeric field which indicates the type of acquisition of an enlistee.

2. REFERENCES.

a. Navy Recruiting Manual, COMNAVCRUITCOMINST 1130.8

3. CODE STRUCTURE.

CHARGEAELE

<u>Code</u>	<u>Description</u>
10	MALE ENLISTED IN READY MARINER (4x10) PROGRAM (WITH OR WITHOUT DELAYED ACTIVE DUTY FOR TRAINING)
11	QUEBEC - NO PRIOR SERVICE OR HAS PRIOR ACTIVE SERVICE OF LESS THAN 6 MONTHS IN OTHER THAN USN OR USNR.
12	QUEBEC - PRIOR USN OR ACTIVE USNR SERVICE LESS THAN 4 MONTHS.
13	QUEBEC - PRIOR NAVAL RESERVE SERVICE (OTHER THAN CACHE), NO PRIOR ACTIVE SERVICE
14	QUEBEC - MUSICIAN
15	QUEBEC - MUSICIAN APPLICANT WHO FAILED THE MUSICAL AUDITION AND WHO ENLISTED FOR GENERAL SERVICE OR IN ANOTHER SPECIAL PROGRAM (NOT USED FOR AN APPLICANT WHO REQUESTS TO BE RETURNED HCME AND WBC, AT A LATER DATE AFTER ARRIVAL AT HCME, ENLISTS IN THE USN)
16	QUEBEC - NAVY INDUCTEE
17	QUEBEC - PRIOR NAVAL RESERVE SERVICE, NO PRIOR ACTIVE SERVICE - RETURNING CACHE
18	ACTIVE MARINER ENLISTEE
19	TAR ENLISTED PROGRAM ENLISTEE

MCN-CHARGEABLE

MALE

<u>Code</u>	<u>Descriptive</u>
21	ROMEQ - PRIOR REGULAR NAVY SERVICE (REENLISTING WITH BROKEN SERVICE).
22	RCMEC - PRIOR ACTIVE USNR SERVICE (INCLUDES 4 OR MORE MONTHS ACDU)
23	RCMEC - PRIOR NAVY INDUCTEE SERVICE
24	RCMEC - PRIOR OTHER SERVICE (OTHER THAN USN, USNR, USMC, OR USMCR)
25	ROMEQ - PRIOR SERVICE (OTHER THAN USN OR USNR). ACCEPTED FOR ENLISTMENT TEMPORARILY IN THE CACHE USNR-8.
32	ZOLU - REENLISTING OVER 24 HOURS BUT WITHIN 3 MONTHS.

FEMALE

<u>Code</u>	<u>Descriptive</u>
41	RECRUIT ENLISTMENT USN
43	REENLISTING USN WITHIN 3 MONTHS
44	REENLISTING USN OVER 3 MONTHS
45	FIRST ENLISTMENT USN PRIOR NAVAL SERVICE OTHER THAN CACHE
46	FIRST ENLISTMENT USN PRIOR OTHER SERVICE
47	FIRST ENLISTMENT USN PRIOR NAVAL RESERVE SERVICE, NO PRIOR ACTIVE SERVICE (RETURNING CACHE)
48	ALL USNR ENLISTMENTS

4. APPLICABLE TRANSACTIONS.

<u>Change Code</u>	<u>Descriptive</u>
1FL	Navy-strength Gains (SCAT)

TYPE OF PROGRAM

1. **DEFINITION:** A. 1-position numeric field indicating the enlistment program.

2. **CODE STRUCTURE:**

1 - **USN initial obligation greater than 5 years:**

BR-CL (EMR 262) < 32 OR = 90 and

SOFT EAOS (EMR 256) - AS-OF-DATE > 60 MONTHS

2 - **USNR THIRTY-SIX MONTH OBLIGATION:**

BR-CL (EMR 262) = 32 OR = 78 AND

RADO-NOS (EMR 305) = 36

3 - **USN TWO YEAR OBLIGATION:**

BR-CL (EMR 262) < 32 OR = 90 AND

EADS (EMR 288) - ADSD (EMR 264) = 24 MONTHS

Blank - Otherwise

MAPMIS SYSTEMS DOCUMENTATION MANUAL, NAVPERS 15,642

Chapter II
Part A
Section 1

Enlisted Data Element Dictionary

SPECIAL PROGRAM CODE/OCCUPATIONAL GROUP (RCRATESPC)

1. DEFINITION. A 5-position alphanumeric field which identifies the program in which enlistment/reenlistment is being made. All accessions must have a 5-digit code:

- a. 1-position CATEGORY (TYPE ENLISTMENT). Position 2124.
- b. 4-position ENLISTED PROGRAM and/or GUARANTEES authorized by the CATEGORY. Positions 2125-2128.

2. REFERENCES.

- a. COMNAVCRUITCOM Notice 1139 of 17 Sep 1975
- b. Navy Recruiting Manual, COMNAVCRUITCOMINST 1139.8

3. CODE STRUCTURE. See REMARK b.

1st Position - Type Enlistment:

<u>Code</u>	<u>Category</u>
C	Upon enlistment as USN CACHE
D	Upon enlistment USNR with delayed active duty (other than Ready Mariner and Reserve Female Enlistment Program)
R	All Ready Mariner and Reserve Female Enlistment Program
A	Upon enlistment USN and upon commencement of active duty as USNR (other than Ready Mariner and Reserve Female Enlistment Program)

2nd, 3rd, 4th and 5th Positions:

Active Mariner Program (A-M)

<u>Code</u>	<u>Description</u>
Z999	A-M, ATP
Z**9	A-M, School
MZ99	A-M, Subfarer

MAPNIS SYSTEMS DOCUMENTATION MANUAL, NAVPERS 15,642

Advanced Electronics Field Program (AEF)

<u>Code</u>	<u>Description</u>
A999	AEF, No Specific School, Non-Sub Volunteer
A**9	AEF, Specific School, Non-Sub Volunteer
A99S	AEF, No Specific School, Sub Volunteer
A**S	AEF, Specific School, Sub Volunteer

Advanced Technical Field (ATF)

<u>Code</u>	<u>Description</u>
B**9	ATF, Specific School

Direct Procurement Enlistment Program (DPEP) excluding NAVETS/OSVETS

<u>Code</u>	<u>Description</u>
C999	DPEP, Designated Striker
C***	DPEP, Ultimate paygrade E-4 to E-7, No "A" School required
D***	DPEP, Ultimate paygrade E-4 to E-7, "A" School required

Medical Technologist Training Program (MEDTECH)

<u>Code</u>
E999

Musician Program

<u>Code</u>
F999

Nuclear Field Program (NF)

<u>Code</u>	<u>Description</u>
G999	NF, No Specific School
G**9	NF, Specific School

Occupational Specialty Program (OCCSPEC)
(other than Philippines)

<u>Code</u>	<u>Description</u>
H429	4YO OCCSPEC

Philippine Recruiting Program

<u>Code</u>	<u>Description</u>
9999	Philippine, Non-OCCSPEC
9299	Philippine, OCCSPEC

Programmed School Input (PSI)

<u>Code</u>
J**9

Ready Mariner Program (R-M)

<u>Code</u>	<u>Description</u>
X**9	R-M, School

Reserve Female Enlistment Program (RFEP)

<u>Code</u>	<u>Description</u>
W**9	RFEP, School

Seafarer/Airman Program

<u>Code</u>	<u>Description</u>
K499	4YO S/A, No coast
K4W9	4YO S/A, West coast
K4E9	4YO S/A, East coast

School Guarantee Program (SGP)

<u>Code</u>	<u>Description</u>
4**9	4YO SGP
5**9	5YO SGP

MAPMIS SYSTEMS DOCUMENTATION MANUAL, NAVPERS 15,642

Subfarer Program

<u>Code</u>	<u>Description</u>
M499	USN 4YO Subfarer, No Coast
M4W9	USN 4YO Subfarer, West Coast
M4E9	USN 4YO Subfarer, East Coast
MZ99	USNR Active Mariner Subfarer

NAVET (other than DPEP) reenlisting under CONTINUOUS service

<u>Code</u>	<u>Description</u>
N999	NAVET, No PRISE I, No PRISE II, No PRISE II PSI and No RESCORE
NM**	NAVET, RESCORE

NAVET (other than DPEP) reenlisting under BROKEN service

<u>Code</u>	<u>Description</u>
7999	NAVET, No PRISE I, No PRISE II, No PRISE II PSI and No RESCORE
7P99	NAVET, PRISE I
7G**	NAVET, PRISE II
7J**	NAVET, PRISE II PSI
7M**	NAVET, RESCORE

OSVET (other than DPEP)

<u>Code</u>	<u>Description</u>
S999	OSVET, No PRISE I, No PRISE II, No PRISE II PSI and No RESCORE
SG**	OSVET, PRISE II
SJ**	OSVET, PRISE II PSI

NAVET/OSVET DPEP

<u>Code</u>	<u>Description</u>
Q999	NAVET, DPEP Designated Striker
Q***	NAVET, DPEP Ultimate paygrade E-4 to E-7
L999	OSVET, DPEP Designated Striker
L***	OSVET, DPEP Ultimate paygrade E-4 to E-7

MAPMIS SYSTEMS DOCUMENTATION MANUAL, NAVPERS 15,642

TAR Enlisted Program (TEP)

<u>Code</u>	<u>Description</u>
Y**9	TEP, School

NOTE:

<u>@OCCSPEC</u>	<u>Code</u>	<u>Occupational Specialty</u>
<u>Category</u>	<u>Code</u>	
OA	A	Operations Specialties, Analysis
OB	B	Operations Specialties, Control
OC	C	Graphic Specialties
OD	D	Administrative Specialties
OE	E	Supply and Accounting Specialties
OJ	J	Electrical Specialties
OK	K	Ordnance Specialties
ON	N	Mechanical Specialties, Precision Equipment
OP	P	Mechanical Specialties, General
OQ	Q	Aviation Maintenance and Handling
OR	R	Mechanical Specialties, Fabrication
OV	V	Aviation Electrical/Electronics
OW	W	Security Group Specialties
OZ	Z	Occupational Specialty, Technical
CB	5	Mechanical Fabrication (Construction)

#Paygrade Code

E-4	4
E-5	5
E-6	6
E-7	7

** Insert 2-position rating code from list following REMARKS.

4. APPLICABLE TRANSACTIONS.

<u>Change Code</u>	<u>Description</u>
E85	Special Program Code
1FL	SCAT Navy-strength Gain
ESR	Enlisted Service Record Navy-strength Gain

5. UPDATE METHODS.

<u>Source</u>	<u>Mode</u>
AFBES	a. Data Set EF.PJB0114B via USAREC (SCAT tape)
Activity	a. Scheduling and Coding Sheet for Enlistees through Armed Forces Examining and Entrance Stations, AA Form 1966 b. Enlistment Contract, DD Form 4
EPMAC	a. Enlisted Change Tape
Pers-352	a. Correction cards

6. REMARKS.

a. This element, established 1 Oct 1975, replaced the elements SPECIAL PROGRAM CODE INDICATOR (SPCIND) and RATE/SPECIAL PROGRAM CODE (RATE/SPC).

b. Until the existing codes for RATE/SPC are converted on the EMB, Positions 2122 thru 2128 will continue to contain RATE/SPC. Accessions as-of 1 Oct 1975 will contain SPC/OCC GRP in Positions 2124 thru 2128.

<u>Rating/ School</u>	<u>Rating Code</u>
AB	AB
ABE	A1
ABH	A2
ABF	A3
AC	AC
AD	AD
ADJ	A4
ADR	A5
AE	AE
AF	AF
AG	AG
AK	AK
AM	AM
AME	A6
AMH	A7
AMS	A8
AO	AO
AQ	AQ
AS	AS
ASE	A9
ASH	AH
ASM	AA

Chapter II
Part A
Section 1

Enlisted Data Element Dictionary

BRANCH AND CLASS OF SERVICE (BRCLASS)

1. DEFINITION. 2-position numeric field which indicates the branch and component of service in which a member is currently serving.

2. REFERENCES.

- a. Navy Recruiting Manual, COMNAVCRUITCOMINST 1130.8
- b. BUPERS Manual, NAVPERS 15791
- c. PAYPERS Manual, NAVSC P-3050

3. CODE STRUCTURE.

<u>Code</u>	<u>Abbr</u>	<u>Description</u>
(blank)		Not Reported
11	USN	Regular Navy
15	USN-NAT	Insular force (Guam or Phillipines)
23	USN-S	Inductee
25	USN-MI	Medical Inductee
32	USNR-E	Naval Reserve (Ready)
68	USNFB-F6	Fleet Reserve (from USN)
78	USNFB-F6	Fleet Reserve (from USNR)
90	USN-RET	Retired Regular Navy
56	USNR-RET	Retired Naval Reserve

4. APPLICABLE TRANSACTIONS.

<u>Change Code</u>	<u>Description</u>
1xx	Navy-strength gains (including 1EL/ESR)
300	Discharge with immediate reenlistment
334	BR/CI change
379/380	Active Duty Obligation Amplification

Chapter II
Part A
Section 1

Enlisted Data Element Dictionary

RESERVE ACTIVE DUTY OBLIGATION, MONTHS (RADOMOS)

1. DEFINITION. A 3-position numeric field representing the number of months of active duty for which a Naval Reservist has an obligation.

2. REFERENCES.

- a. PAYPERS Manual, NAVSO P-3050
- b. Navy Recruiting Manual-ENL, CGNAVCROUITCCMINST 1130.8

3. CODE STRUCTURE.

<u>Code</u>	<u>Description</u>
(xxx)	3-position number of months

4. APPLICABLE TRANSACTIONS.

<u>Change Code</u>	<u>Description</u>
194/195	INVC1/VOL Recalled To Active Duty
300	Discharge, with Immediate Reenlistment
379	ACUOBLI Amplification (see REMARKS)
387	Agreement To Remain on Active Duty, Operative

Chapter II
Part A
Section 1

Enlisted Data Element Dictionary

ENLISTED DESIGNATOR CODE (ENLDESIG)

1. DEFINITION. A 1-position numeric field which indicates a special qualification not necessarily covered by RATE or NEC.

2. REFERENCES.

- a. PAYPERS Manual, Part 9, Chapter 6, NAVSO P-3959
- b. BUPERS Manual, NAVPERS 15791
- c. BUPERS Instruction 1089.51

3. CODE STRUCTURE.

<u>Code</u>	<u>Display</u>	<u>Description</u>
(blank)	(blank)	Not qualified for any designator
1	SS	Designated 'qualified in submarines' USN or USNR
2	SU	Designated Submarine School graduate USN or USNR
3	DV	Qualified Diver
4	PJ	Qualified as a parachutist
5	SQ	Designated 'qualified in submarines' USN or USNR, but not to be assigned to submarine duty without prior approval of the Chief of Naval Personnel
6	NAC	Qualified as 'Naval Aircrewman'
7	SG	Designated "qualified in submarines," but not in submarine source rating
8	SP	To be assigned
9	AP	Qualified as 'Aviation Pilot'

4. APPLICABLE TRANSACTION.

<u>Change Code</u>	<u>Description</u>
333	Change ENLISTED DESIGNATOR CODE

Chapter II
Part A
Section 1

Enlisted Data Element Dictionary

PRESENT RATE CODE (RATEPRESCODES)

1. DEFINITION. A 5-position alphanumeric field which indicates the current RATING (occupational) or apprenticeship (4-positions numeric) and PAY GRADE (1-position alphabetic) related to PRESENT RATE ABBREVIATION.

2. REFERENCES.

- a. PAYPERS Manual, NAVSO P-3050
- b. Manual of Navy Enlisted Manpower and Personnel Classifications and Occupational Standards, Section I (Navy Enlisted Occupational Standards), NAVPERS 18068
- c. Manual Of Advancement In Rating, BUPERSINST 1430.16
- d. BUPERS Notices 1430/1440 series

3. CODE STRUCTURE. See Appendix A.03.

4. APPLICABLE TRANSACTIONS.

<u>Change Code</u>	<u>Description</u>
1xx	Navy-strength gains (initial establishment)
328	Change PRESENT RATE
340	COURT MEMORANDUM

Chapter II
Appendix A

Table 03 -- RATE CODE (See Note)

RATE CODE	RATE ABBR	APPLICABLE PAYGRADE CODE									
		E9 MC	E8 SC	E7 C	E6 1	E5 2	E4 3	E3 SN	E2 SA	E1 SR	
0100	BM	A	J	1	2	3	4	5	6	7	
0150	MA	A	J	1	2	3	4	5	6	7	
0200	QM	A	J	1	2	3	4	5	6	7	
0250	SM	A	J	1	2	3	4	5	6	7	
0300	OS	A	J	1	2	3	4	5	6	7	
0350	EW	A	J	1	2	3	4	5	6	7	
0400	ST	A	J	1	2	3	4	5	6	7	
0401	STG	A	J	1	2	3	4	5	6	7	
0404	STS	A	J	1	2	3	4	5	6	7	
0450	OT	A	J	1	2	3	4	5	6	7	
0500	TM	A	J	1	2	3	4	5	6	7	
0600	GM	A	J	1	2	3	4	5	6	7	
0601	GMM	A	J	1	2	3	4	5	6	7	
0602	GMT	A	J	1	2	3	4	5	6	7	
0604	GMG	A	J	1	2	3	4	5	6	7	
0800	FT	A	J	1	2	3	4	5	6	7	
0801	FTG	A	J	1	2	3	4	5	6	7	
0802	FTM	A	J	1	2	3	4	5	6	7	
0803	FTB	A	J	1	2	3	4	5	6	7	
0810	MT	A	J	1	2	3	4	5	6	7	
0900	MN	A	J	1	2	3	4	5	6	7	
1000	ET	A	J	1	2	3	4	5	6	7	
1001	ETN	A	J	1	2	3	4	5	6	7	
1002	ETR	A	J	1	2	3	4	5	6	7	
1010	DS	A	J	1	2	3	4	5	6	7	
1080	PI	A	J	1	2	3	4	5	6	7	
1100	IM	A	J	1	2	3	4	5	6	7	
1200	OM	A	J	1	2	3	4	5	6	7	
1400	NC	A	J	1	2	3	4	5	6	7	
1500	RM	A	J	1	2	3	4	5	6	7	
1611	CTT	A	J	1	2	3	4	5	6	7	
1622	CTA	A	J	1	2	3	4	5	6	7	
1633	CTM	A	J	1	2	3	4	5	6	7	
1644	CTO	A	J	1	2	3	4	5	6	7	
1655	CTR	A	J	1	2	3	4	5	6	7	
1666	CTI	A	J	1	2	3	4	5	6	7	
1700	YN	A	J	1	2	3	4	5	6	7	
1750	LN	A	J	1	2	3	4	5	6	7	
1800	PN	A	J	1	2	3	4	5	6	7	
1900	DP	A	J	1	2	3	4	5	6	7	
2000	SK	A	J	1	2	3	4	5	6	7	
2100	DK	A	J	1	2	3	4	5	6	7	
2200	MS	A	J	1	2	3	4	5	6	7	
2300	IS	A	J	1	2	3	4	5	6	7	
2490	SH	A	J	1	2	3	4	5	6	7	
2600	JO	A	J	1	2	3	4	5	6	7	
2700	PC	A	J	1	2	3	4	5	6	7	
3100	LI	A	J	1	2	3	4	5	6	7	
3200	DM	A	J	1	2	3	4	5	6	7	
3300	HU	A	J	1	2	3	4	5	6	7	
3600	SN	A	J	1	2	3	4	5	6	7	
3600	SA	A	J	1	2	3	4	5	6	7	
3600	SR	A	J	1	2	3	4	5	6	7	

NAPMIS SYSTEMS DOCUMENTATION MANUAL, NAVPERS 15,642

RATE CODE	RATE ABBR	APPLICABLE PAYGRADE CODE								
		E9 MC	E8 SC	E7 C	E6 1	E5 2	E4 3	E3 FN	E2 FA	E1 FR
3700	MM	A	J	1	2	3	4	5	6	7
3800	EN	A	J	1	2	3	4	5	6	7
3900	MR	A	J	1	2	3	4	5	6	7
4000	BT	A	J	1	2	3	4	5	6	7
4020	BR	A	J	1	2	3	4	5	6	7
4100	EM	A	J	1	2	3	4	5	6	7
4200	IC	A	J	1	2	3	4	5	6	7
4300	HT	A	J	1	2	3	4	5	6	7
4600	PM	A	J	1	2	3	4	5	6	7
4700	ML	A	J	1	2	3	4	5	6	7
5000	FN							5	6	7
5000	FA							6		
5000	FR									7

RATE CODE	RATE ABBR	APPLICABLE PAYGRADE CODE								
		E9 MC	E8 SC	E7 C	E6 1	E5 2	E4 3	E3 CN	E2 CA	E1 CR
5080	CU	A								
5100	EA		J	1	2	3	4	5	6	7
5300	CE		J	1	2	3	4	5	6	7
5380	EQ	A								
5410	EO		J	1	2	3	4	5	6	7
5500	CM		J	1	2	3	4	5	6	7
5600	BU		J	1	2	3	4	5	6	7
5700	SW		J	1	2	3	4	5	6	7
5800	UT	A	J	1	2	3	4	5	6	7
6000	CN							5	6	7
6000	CA							6		
6000	CR									7

MAPMIS SYSTEMS DOCUMENTATION MANUAL, NAVPERS 15,642

RATE CODE	RATE ABBR	APPLICABLE PAYGRADE CODE									
		E9 MC	E8 SC	E7 C	E6 1	E5 2	E4 3	E3 AN	E2 AA	E1 AR	
6080	AF	A									
6180	AV	A									
6200	AD		J								
6205	ADR			1	2	3	4	5	6	7	
6206	ADJ			1	2	3	4	5	6	7	
6300	AT		J	1	2	3	4	5	6	7	
6310	AX		J	1	2	3	4	5	6	7	
6400	AW	A	J	1	2	3	4	5	6	7	
6500	AO	A	J	1	2	3	4	5	6	7	
6520	AQ	A	J	1	2	3	4	5	6	7	
6600	AC	A	J	1	2	3	4	5	6	7	
6700	AB	A	J	1	2	3	4	5	6	7	
6704	ABE			1	2	3	4	5	6	7	
6705	ABF			1	2	3	4	5	6	7	
6706	ABH			1	2	3	4	5	6	7	
6800	AE		J	1	2	3	4	5	6	7	
6900	AM		J	1	2	3	4	5	6	7	
6901	AMS			1	2	3	4	5	6	7	
6902	AMH			1	2	3	4	5	6	7	
6903	AME			1	2	3	4	5	6	7	
7000	PR	A	J	1	2	3	4	5	6	7	
7100	AG	A	J	1	2	3	4	5	6	7	
7200	TD	A	J	1	2	3	4	5	6	7	
7300	AK	A	J	1	2	3	4	5	6	7	
7400	AZ	A	J	1	2	3	4	5	6	7	
7500	AS	A	J	1	2	3	4	5	6	7	
7501	ASE										
7502	ASH										
7503	ASM										
7600	PH	A	J	1	2	3	4	5	6	7	
7800	AN										
7800	AA										
7800	AR										

		E9 MC	E8 SC	E7 C	E6 1	E5 2	E4 3	E3 HN	E2 HA	E1 HR
8000	HM	A	J	1	2	3	4	5		
8000	HN									
8000	HA									
8000	HR									

		E9 MC	E8 SC	E7 C	E6 1	E5 2	E4 3	E3 DN	E2 DA	E1 DR
8300	DT	A	J	1	2	3	4	5	6	7
8300	DN									
8300	DA									
8300	DR									

Note: RATE CODE consists of the above 4-position RATE CODE plus the APPLICABLE PAYGRADE CODE; i.e.: the code for a HTCS is 4300J.

Chapter II
Part A
Section 1

Enlisted Data Element Dictionary

PRIMARY NAVY CLASSIFICATION CODE (PNEC) (PNECDATE)

1. DEFINITION. An 8-position numeric field used as a supplement to the enlisted rating structure (General, Service, and Emergency ratings) which indicates a primary special knowledge or skill for manpower management usage, consisting of:

a. A 4-position numeric NEC Code (Ø15Ø), as outlined in the NEC manual.

b. 4-position numeric data (YRMO - Ø154) which indicates the date on which the PNEC was initially awarded, or, in cases where periodic requalification or recertification is necessary for retention of the PNEC, the date on which requalification or recertification was last accomplished.

2. REFERENCES.

- a. PAYPERS Manual, NAVSO P-3Ø5Ø
- b. BUPERS Notice 1221 series
- c. Manual Of Navy Enlisted Manpower And Personnel Classifications And Occupational Standards, (Navy Enlisted Classifications) Section II, NAVPERS 18Ø68

3. CODE STRUCTURE.

PRIMARY NAVY ENLISTED CLASSIFICATION CODE. See Reference c.

<u>Code</u>	<u>Description</u>
(xxxxYRMO)	4-pos. NEC CODE; 2-pos. year; 2-pos. month

Chapter II
Part A
Section 1

Enlisted Data Element Dictionary

SECONDARY NAVY ENLISTED CLASSIFICATION CODE (SNEC) (SNECDATE)

1. DEFINITION. SNEC is a manpower management - 8-position numeric field used as a supplement to the Enlisted Rating Structure (General, Service, and Emergency Ratings) which indicates:

a. A 4-position numeric secondary skill or special knowledge - 015E.

b. A 4-position numeric field (YRMO - 0162) which indicates either the date on which the SNEC was initially awarded or, in cases where periodic requalification or recertification is required for retention of the SNEC, the date on which such requalification or recertification was accomplished.

2. REFERENCES.

- a. NAVPERS Manual, NAVSO P-3050
- b. BUPERS Notice 1221 series
- c. Manual Of Navy Enlisted Manpower And Personnel Classifications And Occupational Standards, (Navy Enlisted Classifications) Section II, NAVPERS 1b068

3. CODE STRUCTURE. See Reference c.

<u>Code</u>	<u>Description</u>
(xxxxYRMO)	4-pos. NEC CODE; 2-pos. year; 2-pos. month

4. APPLICABLE TRANSACTIONS.

<u>Change Code</u>	<u>Description</u>
NEA	Change all NECs (BUMED/Pers-53)
NEB	Add one NEC (BUMED/Pers-53)
NEP	Add one NEC (initial input from UNITAS, via USAREC)
328	Change PRESENT RATE
338	DOD Occupational Grouping Code (E-1 to E-3 only)
340	Court Memoranda

Chapter II
Part A
Section 1

Enlisted Data Element Dictionary

ACTIVE DUTY SERVICE DATE (ADSD)

1. DEFINITION. A 6-position numeric date which reflects all periods of Active Federal Military Service in commissioned, warrant, flight officer, or enlisted status. If there is no break in active duty from date of original entry on such duty, ADSD is the date of original entry on active duty. If there is a break in active duty, ADSD is later than the date of original entry by a period equivalent to the break (or breaks). In computing, include all periods of active duty for training. For a tour of 30 days or less, count the actual number of days. For longer tours, subtract the first day of the tour from the last day and add 1 day to the remainder (see REMARK e.).

2. REFERENCES.

- a. BUPERS Manual, NAVPERS 15791
- b. Navy Recruiting Manual, COMNAVCRUITCOMINST 1130.8
- c. PAYPERS Manual, NAVSO P-3050

3. CODE STRUCTURE.

<u>Code</u>	<u>Description</u>
(blank)	Not reported
(YRMODA)	2-pos. year; 2-pos. month; 2-pos. day

4. APPLICABLE TRANSACTIONS.

<u>Change Code</u>	<u>Description</u>
050	Record Of Unauthorized Absence
1FL/ESR	SCAT/ESR gains to Navy-strength
1xx	Navy-strength gains
340	Court Memorandum
359	ADSD Change
379/380	ACEUOBLI Amplification (see REMARK e for LOST TIME)

Chapter II
Part A
Section 1

Enlisted Data Element Dictionary

FAY ENTRY BASE DATE (FEED)

1. DEFINITION. A 6-position numeric date field (YEMCEA) that indicates the date from which the total net federal service creditable for pay purposes may be computed. The FEED is computed by subtracting net prior service from the date the current period of service commenced.

2. REFERENCES.

- a. Navy Recruiting Manual, COMNAVCRUITCOMINST 1130.8
- b. BUPERS Manual, NAVPERS 15791
- c. Department of Defense Pay and Entitlements Manual, DCDEM
- d. PAYPERS Manual, NAVSO P-3050

3. CODE STRUCTURE.

<u>Code</u>	<u>Description</u>
(blank)	Not reported
(000000)	FLEXO, Undetermined (to be researched/ reported)
(YRMDA)	2-pos. year; 2-pos. month; 2-pos. day

4. APPLICABLE TRANSACTIONS.

<u>Change Code</u>	<u>Description</u>
050	Record of Unauthorized absence
1FL/ESR	SCAT (FLEXC)/Enlisted Service Record Gains
340	Court Memorandum
390	FEED Change
379/380	ACDUOBLI Application for LOST TIME

Chapter II
Part A
Section 1

Enlisted Data Element Dictionary

CURRENT ENLISTMENT DATE (CED)

1. DEFINITION. A 6-position field which indicates the date a member of the Regular Navy or Naval Reserve commenced his current enlistment, as recorded in his Enlistment/Reenlistment Contract. CED does not apply to Fleet Reserve or Retired personnel.

2. REFERENCES.

- a. Navy Recruiting Manual, COMNAVCRUITCCMINST 1130.8
- b. BUPERS Manual, NAVPERS 15791
- c. PAYPERS Manual, NAVSO P-3050

3. CODE STRUCTURE.

<u>Code</u>	<u>Description</u>
(YRMODA)	2-pos. year; 2-pos. month; 2-pos. day

4. APPLICABLE TRANSACTIONS.

<u>Change Code</u>	<u>Description</u>
B70	CURRENT ENLISTMENT DATE change
1xx	Navy-strength gains (including IFL/ESR)
300	Discharge with Immediate Reenlistment
379/380	Active Duty Obligation Amplification

Chapter II
Part A
Section 1

Enlisted Data Element Dictionary

CURRENT ACTIVE DUTY DATE (CADE)

1. DEFINITION. A 6-position numeric field that indicates the actual date on which a member commenced his current Active Duty. This date is applicable to Naval Reservists, Fleet Reservists, and Retired members called or recalled to Active Duty. It also applies to members who are administratively transferred to the Fleet Reserve or the Retired list, but remained on Active Duty. If a Naval Reservist on Active Duty reenlists USNR and remains on Active Duty, then his CADE is the date of the reenlistment.

2. REFERENCES.

- a. BUPERS Manual, NAVPERS 15791
- b. Enlisted Transfer Manual, NAVPERS 15909
- c. PAYPERS Manual, NAVSO P-3050
- d. BUPERS Instruction 1130.4

3. CCDE STRUCTURE.

<u>Code</u>	<u>Description</u>
(YRMODA)	2-pos. year; 2-pos. month; 2-pos. day

4. APPLICABLE TRANSACTIONS.

<u>Change Code</u>	<u>Description</u>
B76	Change CURRENT ACTIVE DUTY DATE
1FL/ESH	SCAT (FLIXC)/Enlisted Service Record gains.
194/195	INVCL/VOL Recall to Active Duty
300	Discharge with immediate Reenlistment
379/380	Active Duty Obligation Amplification (See REMARKS).

Chapter II
Part A
Section 1

Enlisted Data Element Dictionary

EXPIRATION OF ACTIVE OBLIGATED SERVICE (EAOS)

1. DEFINITION. A 6-position numeric field which indicates when a member is eligible for separation from active duty. It is computed as CED/CADB plus TERMEM1/TERMACDU. It is adjusted by adding operative extensions and deleting lost time.

2. REFERENCES.

- a. BUPERS Manual, NAVPERS 15791
- b. Enlisted Transfer Manual, NAVPERS 15909
- c. PAYPERS Manual, NAVSO P-3050

3. CODE STRUCTURE.

<u>Code</u>	<u>Description</u>
(YEMODA)	2-pos. year; 2-pos. month; 2-pos. day

4. APPLICABLE TRANSACTIONS.

<u>Change Code</u>	<u>Description</u>
C00	ACEUOBLI Correction
050	RECCHD CP UA
1PL/ESH	SCAT (FLIXC)/Enlisted Service Record gain
194/195	INVOL/VCL Recalled To Active Duty
300	Discharge With Immediate Reenlistment
340	COURT MEMORANDUM
379/380	ACEUCBLI Application
381	ACEUOBLI Correction (BUPERS research only)
383	Agreement To Extend Enlistment, Operative
387	Agreement To Remain On Active Duty, Operative
389	Agreement To Extend USNR Enlistment, Operative

Chapter II
Part A
Section 1

Enlisted Data Element Dictionary

SOFT EXPIRATION OF ACTIVE OBLIGATED SERVICE (SOFTREACS)

1. DEFINITION. A 6-position numeric field (YRMODA) which reflects a member's present total obligation. This date includes expiration of present enlistment and any extension he may have executed.

2. REFERENCE.

- a. BUPERS Manual, NAVPERS 15791
- b. Enlisted Transfer Manual, NAVPERS 15909
- c. PAYPERS Manual, NAVSO P-3050

3. CODE STRUCTURE.

<u>Code</u>	<u>Description</u>
(YRMODA)	2-pos. year; 2-pos. month; 2-pos. day

4. APPLICABLE TRANSACTIONS.

<u>Change Code</u>	<u>Description</u>
000	ACDUOELI Correction
050	RECORD OF DA
1FL/ESH	SCAT (FLZXC)/Enlisted Service Record gain
194/195	INVOL/VCL Recalled To Active Duty
300	Discharge With Immediate Reenlistment
340	COURT MEMORANDUM
379/380	ACDUOBLI Amplification
381	ACDUOELI Correction (BUPERS research only)
383	Agreement To Extend Enlistment, Operative
387	Agreement To Remain On Active Duty, Operative
389	Agreement To Extend USNR Enlistment, Operative

EADS-CHANGE-INDICATOR

1. DEFINITION: A. 1-position numeric field indicating the cause of a EAOS change. This indicator is based on transaction records from the Audit/Trail file. If more than one transaction has occurred during the quarter, the last one is used.

2. CODE STRUCTURE:

1 - Immediate Reenlistment -

CHANGE-CODE (AUDIT/TRAIL 278) = 130, 131

2 - Reenlistment Continuous Service -

CHANGE-CODE (AUDIT/TRAIL 278) = 140, 141

3 - Extension - (No Bonus)

CHANGE-CODE (AUDIT/TRAIL 278) = 38X

CHANGE-DESCRIPTION (AUDIT/TRAIL 313) NOT = B

4 - Bonus Extension - (Bonus)

CHANGE-CODE (AUDIT/TRAIL 278) = 38X

CHANGE-DESCRIPTION (AUDIT/TRAIL 313) = B

5 - USNR to USN -

CHANGE-CODE (AUDIT/TRAIL 278) = 10X, 11X

6 - Returned from Desertion -

CHANGE-CODE (AUDIT/TRAIL 278) = 191,193

9 - Reason Unknown

Blank - No Change

MAPMIS SYSTEMS DOCUMENTATION MANUAL, NAVPERS 15,642

STF-L-87-91

**Chapter II
Part A
Section 1**

Enlisted Data Element Dictionary

ONBOARD ACCOUNTING CATEGORY CODE (ONBDACCTG)

1. **DEFINITION.** A 3-position numeric field which reflects the reason a member is attached to an activity.
2. **REFERENCES.**
 - a. PAYPERS Manual, NAVSO P-3050
 - b. BUPERS Instruction 1030.51
 - c. Navy Recruiting Manual, COMNAVCRUITCOMINST 1130.8
3. **CODE STRUCTURE.** See Appendix A.09.
4. **APPLICABLE TRANSACTIONS.**

<u>Change Code</u>	<u>Description</u>
1FL	SCAT/Flexowriter Gain
ESR	Enlisted Service Record Gain
1xx	Navy-strength Gain
18x	NES Gain from OCARS
191/193	Surrendered/Delivered Deserter
194/195	Involuntarily/Voluntarily Recalled to Active Duty
2xx	Activity-strength Gain
300	Discharge/Immediate Reenlistment (OCR)
376	ACC Change

Chapter II
Appendix A

Table 09 -- ACCOUNTING CATEGORY CODE

<u>Code</u>	<u>Description</u>
100	For Duty
101	Gained - failed to report for Duty
102	For Duty - termination of Officer Appointment
103	For Duty - TEMAC/TAR
104	For Duty - Humanitarian Assignment (over 6 months)
105	For Duty - Limited Duty (designator not assigned)
106	For Duty CFO
107	For Duty - Mobilization
108	For Duty - Guaranteed PSI Program
150	TEM DU - PSI
320	TEM DU - For Further Assignment (FFA)
330	TEM DU - For Further Transfer (FFT)
340	TEM DU - Under Instruction Less Than 20 weeks (recruit training)
341	TEM DU - Under Instruction Less Than 20 weeks (other than RECTRA)
342	For Duty Under Instruction - 20 weeks or greater (other than ADCOP, NESEP, NENEP or NEDEP)
343	For Duty - 20 weeks or greater (ADCOP, NESEP, NENEP, NEDEP, or NAPS)
350	TEM DU - Not Otherwise Defined
351	Gained - Failed To Report For Temporary Duty
352	TEM DU CFO (less than 6 months)
353	TEM DU - Termination of Officer Appointment
354	TEM DU - Humanitarian Assignment (6 months or less)
370	TEM DU - Under Treatment in any Medical Facility other than a Medical Holding Company
371	TEM DU - Under Treatment In A Medical Holding Company
372	TEM DU - Hospitalized at non-military medical facility
380	TEM DU - Pending Separation, Discharge, Release, Retirement
381	TEM DU - Pending Separation, Discharge, Release, Retirement (non- pay status, at home waiting final disposition)
390	TEM DU - Disciplinary Status (at other than correctional activity)
391	TEM DU - In Confinement At A Correctional Activity
392	TEM DU - Confined Or Held By Civil Authorities
393	TEM DU - Home awaiting results of Appellate Review

NOTES:

- a. First position
 - (1) 1 indicates a charge against allowance.
 - (2) 3 indicates no charge against allowance.
- b. Second position indicates the general reason for a member to be on board.
- c. Third position is for EPMAC use.
- d. PSI (ACC. 15x) must be identified on BUPERS Report 1080-14 as PSI and never as a PL.

Chapter II
Part A
Section 1

Enlisted Data Element Dictionary

ONBOARD SEA/SHORE CODE (ONBDSS)

1. DEFINITION. A 1-position numeric field which indicates an activity's type of duty classification.

2. REFERENCES.

- a. Enlisted Transfer Manual, NAVPERS 15909
- b. Pers-3C Activity Master File ("A" File)
- c. BUPERS Instruction 1780.51

3. CODE STRUCTURE.

<u>Code</u>	<u>Description</u>
1	Shore Duty
2	Sea Duty
3	Overseas Duty
4	Toured Sea Duty (non-rotated ships)
5	Neutral Duty
6	Preferred Overseas Shore Duty

4. APPLICABLE TRANSACTIONS.

<u>Change Code</u>	<u>Description</u>
1FL	Navy-Strength gain (SCAT/FLEXO)
ESR	Navy-strength gain (Enlisted Service Record)
18x	NES Gain from OCARS
191/193	Surrendered Deserter/Returned Deserter
2xx	Activity-strength gain
CAC	CACHE gain

Chapter II
Part A
Section 1

Enlisted Data Element Dictionary

ONBOARD DATE TRANSFERRED (ONBDTRFDT)

1. DEFINITION. A 6-position numeric field (YRMODA) which indicates the actual date member was transferred from the Activity.

2. REFERENCES.

- a. Enlisted Transfer Manual, NAVPERS 15909
- b. PAYPERS Manual, NAVSO P-3050

3. CODE STRUCTURE.

<u>Code</u>	<u>Description</u>
(blank)	Not Applicable
(YRMODA)	2-pos. year; 2-pos. month; 2-pos. day

4. APPLICABLE TRANSACTIONS.

<u>Change Code</u>	<u>Description</u>
6xx	Activity-strength Transfer
7xx	Activity-strength Loss
717	Missing In Action (Activity-strength Loss)
95x	NES Losses to OCARS

5. UPDATE METHODS.

<u>Source</u>	<u>Mode</u>
Activity	a. Personnel Diary, NAVPERS 1070/75
EPHAC	a. Enlisted Change Tape
Census Match EPHAC	a. Enlisted Change Tape

STF-L-100-104

PAST ACTUAL UIC

(SEE STF-L-87-91)

SRB - RECEIVED INDICATOR

1. **DEFINITION:** A. 1-position field indicating whether SRB has been paid SRB.

2. **CODE STRUCTURE:**

1 - Received SRB -

SRB-INSTALLMENT-PAID

(EMR 2340 POS 11) > 0

0 - Did not receive SRB

SRB-INSTALLMENTS-PAID NOT > 0

Chapter II
Part A
Section 1

Enlisted Data Element Dictionary

SELECTIVE REENLISTMENT BONUS (SRBZONEDATA)

1. DEFINITION. A 15-position element relative to a bonus which may be awarded to an enlisted member in a designated rating or NEC, who reenlists or extends his enlistment for at least 3 years. The purpose of the SRB program is to increase the number of reenlistments in those ratings characterized by retention levels insufficient to adequately man the career force by paying a reenlistment bonus incentive. The bonus will be paid in addition to all pay and allowances to which the member is otherwise entitled.

2. REFERENCES.

- a. BUPERS Instruction 1133.26
- b. BUPERS Instruction 1133.28
- c. PAYPERS Manual, NAVSO P-3050
- d. Military Pay and Allowances Entitlements Manual, DODPM
- e. Navy and Marine Corps Military Pay Procedures, NAVSO P-3007
- f. DOD Instruction 1304.22
- g. DOD Directive 1304.21
- h. SECNAV Instruction 7220.72

3. CODE STRUCTURE. A 15-position field depicting the Zone and related information (see References a and b):

<u>Code</u>	<u>Description</u>
A	At least 21 months of continuous naval service (excluding ACDUTRA), but not more than 6 years of total active military service
B	At least 6 but not more than 10 years continuous active military service
C	Broken service, otherwise Zone A eligibility. Time lapsed since last discharge/RAD is greater than 3 months and equal to or less than 1 year

- D Broken service, otherwise Zone A eligibility. Time lapsed since last discharge/RAD is greater than 1 year and equal to or less than 2 years
- E Broken service, otherwise Zone B eligibility. Time lapsed since last discharge/RAD is greater than 3 months and equal to or less than 1 year
- F Broken service, otherwise Zone B eligibility. Time lapsed since last discharge/RAD is greater than 1 year and equal to or less than 2 years

Positions 2-5

(YRMO) Effective date

Positions 6-9

(xxxx) Rating or NEC for which payment made

Position 10

1-6 Number of payments authorized

Position 11

1-6 Number of payments received

Position 12 (Payment Category)

- A Annual Installment (2nd and subsequent)
- D Advanced payment (one or more annual installments paid in advance. Terminal installment paid first)
- I Initial Installment
- L Lump-Sum payment made
- R Remaining Amount payment made
- X Accelerated (next anniversary installment moved ahead)

Position 13

(Y) Last position of Fiscal Year of Effective Date Of Payment (generated)

Position 14 (Skill/Rating Indicator)

Y Yes, member serving in Rating/NEC authorized
 N No, member not serving in Rating/NEC authorized
 B Broken Service enlistment/reenlistment

Position 15 (Award Level)

1-6 The multiple of the monthly basic pay to which the member was entitled at the time of discharge or release (see Enclosures to Reference (a) for applicable levels)

4. APPLICABLE TRANSACTIONS.

<u>Change Code</u>	<u>Description</u>
QR5	Selective Reenlistment Bonus

5. UPDATE METHODS.

<u>Source</u>	<u>Mode</u>
Activity	a. Military Pay Order (Single), NAVCOMPT 3060 b. Administrative Remarks, NAVPERS 1070/613 (Page 13)
NFC, Cleveland	a. Data Set EF.PNFC602
Pers-53	a. Corrected QRB TACS (cards)

6. REMARKS.

- a. A member will have data in SRB Zone 'A' or SRB Zone 'B', but not both.
- b. This element has replaced VRB, which is no longer being maintained.
- c. For specific eligibility requirements, see References (a & b).

MAPMIS SYSTEMS DOCUMENTATION MANUAL, NAVPERS 15,642

Chapter II
Part A
Section 1

Enlisted Data Element Dictionary

REENLISTMENT QUALITY CONTROL CODE (REENQUALCONTROL)

1. DEFINITION. A 2-position alphanumeric field which indicates the type of reenlistment recommendation a member received upon separation from his last enlistment (USN or USNR). See REMARKS.

2. REFERENCES.

- a. Navy Recruiting Manual, COMNAVCRUITCOMINST 1130.8
- b. PAYPERS Manual, NAVSO P-3050
- c. BUPERS Instruction 1900.2
- d. BUPERS Instruction 1133.22

3. CODE STRUCTURE. (See Reference c).

<u>Code</u>	<u>Description</u>
00	Not reported
10	Recommended for Reenlistment
R1	Recommended for Preferred Reenlistment
20	Recommended for Reenlistment but ineligible because of status: Fleet Reserve, Retired (except transfer to TDRL), Commissioned Officer, Warrant Officer, Midshipman, and Cadet.
3(x)	Recommended for Reenlistment except for disqualifying factor represented by (x), listed below: <ul style="list-style-type: none"> A - Alien (when discharged IAW BUPERS Manual 3850220 (1) (V) Marriage to alien not eligible for entry into U.S.) B - Parenthood/Pregnancy C - Conscientious Objector D - Demonstrated dependency or hardship but not meeting requirements of BUPERSMAN 3850240 E - Erroneous induction or enlistment G - Condition (not physical disability) interfering with performance of duty H - Hardship

- K - Disenrolled from Naval Academy or other officer program - not considered qualified for enlisted status
 - L - Favorable recommendation of board which directed separation
 - P - Physical disability (includes discharge and transfer to TDRL)
 - Q - Disqualified for officer candidate training (not PQ for appointment as officer in the Naval service)
 - R - Eligible for a probationary 2-year reenlistment (See BUPERSINST. 1133.22D)
 - S - Sole surviving son
 - T - Overweight/Overheight
 - U - Minority age
 - V - Overage for Active Service
 - X - Motion Sickness/Nonswimmer
- Not Recommended for Reenlistment

4y

4. APPLICABLE TRANSACTIONS.

<u>Change Code</u>	<u>Description</u>
1xx	Navy-strength gains
1FL	Navy-strength gain (SCAT)
ESR	Navy-strength gain (Enlisted Service Record)
300	Discharged/Immediate Reenlistment (OCR)
95x	NES Losses to OCARS

5. UPDATE METHODS.

<u>Source</u>	<u>Mode</u>
Activity	a. Immediate Reenlistment Contract (OCR), NAVPERS 1070/601 b. Personnel Diary, NAVPERS 1070/75
AFES	a. SCAT transactions via USAREC SCAT tape
Pers-3512	a. EP.OCRTAC to NES Daily Update b. Error cards to Pers-3522 for research
EPHAC	a. Enlisted Change Tape
OCARS	a. 95x TACs from OCARS/NES interface

Chapter II
Part A
Section 1

Enlisted Data Element Dictionary

ATTRITION LOSS DATE OF OCCURRENCE (PASTLOSSDT)

1. DEFINITION. A 6-position numeric field (YRMODA) which indicates the date on which the member was lost to Active Enlisted Strength by discharge, release to inactive duty, death, desertion, retirement, etc.

2. REFERENCES.

a. PAYPERS Manual, NAVSO P-3050

3. CODE STRUCTURE.

<u>Code</u>	<u>Description</u>
(YRMODA)	2-pos. year; 2-pos. month; 2-pos. day

4. APPLICABLE TRANSACTIONS.

<u>Change Code</u>	<u>Description</u>
8xx	Navy-strength loss
9xx	Navy-strength loss
95x	NES Losses to OCARS

5. UPDATE METHODS.

<u>Source</u>	<u>Mode</u>
Activity	a. Personnel Diary, NAVPERS 1070/75
EPHAC	a. Enlisted Change Tape
OCARS	a. 95x TACs from NES/OCARS interface

6. REMARKS.

a. NES Losses to OCARS cause a Loss/Hold SCIND Code to be generated.

Chapter II
Part A
Section 1

Enlisted Data Element Dictionary

ATTRITION LOSS CHANGE CODE (LOSSCHGCODE)

1. DEFINITION. A 3-position numeric standard MAPNIS code indicating the reason for a loss to Navy-strength

2. REFERENCES.

- a. PAYPERS Manual, NAVSO P-3050
- b. DODINST 1336.1
- c. BUPERSINST 1900.4 (DEPARTMENTAL)
- d. BUPERSINST 1900.2

3. CODE STRUCTURE.

See Transaction Code (TAC) writeups in Chapter IV of this manual. The code is validated by table look-up in EPMAC/BUPERS programs.

4. APPLICABLE TRANSACTIONS.

<u>Change Code</u>	<u>Description</u>
8xx	Navy-strength loss
9xx	Navy-strength loss

5. UPDATE METHODS.

<u>Source</u>	<u>Mode</u>
Activity	a. Personnel Diary, NAVPERS 1070/75
EPMAC	a. Enlisted Change Tape

6. REMARKS.

a. Navy Standard Loss Codes (within NES) differ from DOD Loss Codes listed in the above references.

Chapter II
Part A
Section 1

Enlisted Data Element Dictionary

ATTRITION LCSS DEPARTMENT OF DEFENSE LOSS CODE (LCSSDCGCEZ)

1. DEFINITION. A 3-position alphanumeric code which indicates the reason for a member's separation from active service. This element is required by DCD to establish standard reporting criteria for all Armed Forces of the United States.

2. REFERENCES.

- a. PAYPERS Manual, NAVSO F-3050
- b. BUPERS Manual, NAVPERS 15791
- c. BUPERSINST 1900.2
- d. BUPERSINST 1900.4 (Departmental)
- e. BUPERS Instruction 1080.50

3. CODE STRUCTURE.

See References c. and d. for codes (see also Chapter IV, 8xx/9xx TACs)

4. APPLICABLE TRANSACTIONS.

Change Code

Description

300	Discharge with Immediate Reenlistment
8xx	Navy-strength lcss
9xx	Navy-strength lcss
95x/961	OCARS Losses to Enlisted Strength
996	Loss data correction

APPENDIX B
STF-B DATA ELEMENTS AND CODING STRUCTURES

STF-B

POSITION CORRESPONDENCE WITH AUDIT/TRAIL AND EMR FILES

<u>DATA ELEMENT</u>	<u>Length</u>	<u>Start</u>	<u>Trans</u>	<u>EMR</u>
Social Security No.	9	1	1	1
Home of record	2	10	53	83
DoD-AFEES	3	12	163	646
SCREEN	3	15	--	2198
Mental Apt Test ID	2	18	--	2300
Mental Apt Test Results	26	20	--	2302
School history (5x8)	40	46	--	1166
Completion date (4)				
Course code (4)				
School history				
Student action (5x2)	10	86	--	339
School type (5x1)*	5	96	--	--
School course code TDPG-1	4	101	--	1616
School course code TDPG-2	4	105	--	1721
School course code TDPG-3	4	109	--	1826
School type TDPG (3x1) *	3	113	--	--
School course code avail	4	116	--	2280
School type avail *	1	120	--	--

* Computed STF data elements

Chapter II
Part A
Section 1

Enlisted Data Element Dictionary

HOME OF RECORD (HCME-HECCRE)

1. DEFINITION. A 2-position alphanumeric field which indicates the state, U.S. possession, or country a member has reported as his/her Home of Record.

2. REFERENCES.

- a. Navy Recruiting Manual, COMNAVCRUITCOMINSI 139.8
- b. Manual For Standard Data Elements, DGD 5000.12

3. CODE STRUCTURE. See Appendix A.16.

4. APPLICABLE TRANSACTIONS.

<u>Change Code</u>	<u>Description</u>
1FL	SCAT Navy-strength gain
ESR	Navy-strength gain
C41	Change State of Residence
308	Immediate Reenlistment

5. UPDATE METHODS.

<u>Source</u>	<u>Mode</u>
Activity	a. Enlistment Contract, DD Form 4 (establish) b. Letter to Pers-38 (change)
EFMAC	a. Enlisted Change Tape
Pers-3522	a. Cards to the UPDATE
Pers-38	a. Confirmation/approval forwarded to Pers-3522

Chapter II
Appendix A

Table 16 -- COUNTRIES OF THE WORLD
and
STATES OF THE UNITED STATES

<u>Code</u>	<u>Country/State</u>	<u>Abbreviation</u>
AF	Afghanistan	--
AL	Albania	--
AG	Algeria	--
AQ	American Samoa	--
AN	Andorra	--
AO	Angola	--
AV	Anguilla	--
AY	Antarctica	--
AC	Antigua	--
AR	Argentina	--
AT	Ashmore and Cartier Islands	--
AS	Australia	--
AU	Austria	--
BF	Bahama Islands	--
BA	Bahrain	--
BG	Bangladesh	--
BB	Barbados	--
BE	Belgium	--
BD	Bermuda	--
BT	Bhutan	--
BL	Bolivia	--
BC	Botswana	--
BV	Bouvet Is.	--
BR	Brazil	--
BH	Belize	--
IO	British Indian Ocean Territory	--
BP	British Solomon Islands	--
VI	British Virgin Islands	--
BX	Brunei	--
BU	Bulgaria	--
BH	Burma	--
BY	Burundi	--
CB	Cambodia	--
CM	Cameroon	--
CA	Canada	--
PQ	Canal Zone	--
EQ	Canton and Enderbury Islands	--
CV	Cape Verde Is.	--
CJ	Cayman Islands	--
CT	Central African Republic	--
CD	Chad	--

MAPMIS SYSTEMS DOCUMENTATION MANUAL, NAVPERS 15,642

<u>Code</u>	<u>Country/State</u>	<u>Abbreviation</u>
CI	Chile	--
CH	China, Peoples Republic of	--
TW	China, Republic of	--
KT	Christmas Is. (Indian Ocean)	--
CK	Cocos Is. (Indian Ocean)	--
CO	Colombia	--
CN	Comoro Is.	--
CF	Congo (Brazzaville)	--
CR	Coral Sea Island Territory	--
CW	Cook Islands	--
CS	Costa Rica	--
CU	Cuba	--
CY	Cyprus	--
CZ	Czechoslovakia	--
DM	Dahomey	--
DA	Denmark	--
DO	Dominica	--
DR	Dominican Republic	--
EC	Ecuador	--
EG	Egypt	--
ES	El Salvador	--
EK	Equatorial Guinea	--
ET	Ethiopia	--
FO	Faeroes Is.	--
FA	Falkland Is.	--
FJ	Fiji	--
FI	Finland	--
FR	France	--
FG	French Guiana	--
FP	French Polynesia	--
FS	French Southern and Antarctic Lands	--
FT	French Territory of the Afars and Issas	--
GB	Gabon	--
GA	Gambia	--
GZ	Gaza Strip	--
GE	Germany, Federal Republic of	--
GC	Germany, East	--
GH	Ghana	--
GI	Gibraltar	--
CN	Gilbert and Ellice Islands (Includes Central and Southern Line Islands)	--
GR	Greece	--
GL	Greenland	--
GJ	Grenada	--
GP	Guadeloupe	--
GQ	Guam	--

MAPHS SYSTEMS DOCUMENTATION MANUAL, NAVPERS 15,642

<u>Code</u>	<u>Country/State</u>	<u>Abbreviation</u>
GT	Guatemala	--
GV	Guinea	--
GY	Guyana	--
HA	Haiti	--
HI	Heard and McDonald Islands	--
HO	Honduras (Includes Swan Islands)	--
HK	Hong Kong	--
HU	Hungary	--
IC	Iceland	--
IN	India	--
ID	Indonesia	--
IR	Iran	--
IZ	Iraq	--
IY	Iraq-Saudi Arabia Neutral Zone	--
EI	Ireland	--
IS	Israel	--
IW	Israel-Jordan Demilitarized Zones	--
IU	Israel-Syria Demilitarized Zones	--
IT	Italy	--
IV	Ivory Coast	--
JM	Jamaica	--
JN	Jan Mayen	--
JA	Japan (Includes Ryukyu Is.)	--
JQ	Johnston Atoll	--
JO	Jordan	--
KE	Kenya	--
KN	Korea, North	--
KS	Korea, Republic of	--
KU	Kuwait	--
LA	Laos	--
LE	Lebanon	--
LT	Lesotho	--
LI	Liberia	--
LY	Libya	--
LS	Liechtenstein	--
LU	Luxembourg	--
MC	Macao	--
MA	Madagascar	--
MI	Malawi	--
MY	Malaysia	--
MV	Maldives	--
ML	Mali	--
MT	Malta	--
MB	Martinique	--
MR	Mauritania	--
MP	Mauritius	--

MAPMIS SYSTEMS DOCUMENTATION MANUAL, NAVPERS 15,642

<u>Code</u>	<u>Country/State</u>	<u>Abbreviation</u>
MX	Mexico	
MQ	Midway Is.	
MN	Monaco	
HG	Mongolia	
MH	Montserrat	
MO	Morocco	
MZ	Mozambique	
NR	Nauru	
NP	Nepal	
NL	Netherlands	
NA	Netherlands Antilles	
NC	New Caledonia	
NE	New Hebrides	
NZ	New Zealand	
NU	Nicaragua	
NG	Niger	
NI	Nigeria	
NE	Niue	
NF	Norfolk Is.	
NO	Norway	
MU	Oman	
PK	Pakistan	
PN	Panama	
PP	Papua New Guinea	
PF	Paracel Islands	
PA	Paraguay	
PE	Peru	
RP	Philippines	
PC	Pitcairn	
PL	Poland	
PO	Portugal	
PU	Portugese Guinea	
PT	Portugese Timor	
RQ	Puerto Rico	
QA	Qatar	
RE	Reunion	
RO	Romania	
RW	Rwanda	
SC	St. Christopher Nevis	
SH	St. Helena	
ST	St. Lucia	
SB	St. Pierre and Miquelon	
VC	St. Vincent	
SM	San Marino	
TP	Sao Tome E Principe	
SA	Saudi Arabia	
SC	Senegal	
SE	Seychelles	
SL	Sierra Leone	

MAPS SYSTEMS DOCUMENTATION MANUAL, NAVPERS 15,642

<u>Code</u>	<u>Country/State</u>	<u>Abbreviation</u>
SK	Sikkim	--
SN	Singapore	--
CE	Sri Lanka (Ceylon)	--
SO	Somalia	--
SP	South Africa	--
WA	South-West Africa	--
RH	Southern Rhodesia	--
UR	Soviet Union	--
SP	Spain	--
SS	Spainsh Sahara	--
ME	Spanish Terr. Of Northern Morocco	--
PG	Spratly Is.	--
SU	Sudan	--
NS	Surinam	--
SV	Svalbard	--
WZ	Swaziland	--
SW	Sweden	--
SZ	Switzerland	--
SY	Syria	--
TZ	Tanzania	--
TH	Thailand	--
TO	Togo	--
TL	Tokelau Isalnds	--
TN	Tonga	--
TD	Trinidad and Tobago	--
TQ	Trust Territory of the Pacific Islands	--
TS	Tunisia	--
TU	Turkey	--
TK	Turks and Caicos Islands	--
UG	Uganda	--
TC	United Arab Emirates	--
UK	United Kingdom	--
US	United States	--
BQ	United States Misc. Caribbean Islands	--
IQ	United States Misc. Pacific Islands	--
UV	Upper Volta	--
UY	Uruguay	--
VT	Vatican City	--
VE	Venezuela	--
VN	Vietnam, North	--
VS	Vietnam, Republic of	--
VQ	Virgin Islands	--
WQ	Wake Is.	--
WF	Wallis and Futuna	--
WB	West Berlin	--

<u>Code</u>	<u>Country/State</u>	<u>Abbreviation</u>
WS	Western Samoa	--
YE	Yemen Arab Republic	--
YS	Yemen, Peoples Democratic Republic of	--
YO	Yugoslavia	--
CG	Zaire, Republic of	--
ZA	Zambia	--
01	Alabama	ALA
02	Alaska	ALS
04	Arizona	ARZ
05	Arkansas	ARK
06	California	CAL
08	Colorado	COL
09	Connecticut	CONN
10	Delware	DEL
11	District of Columbia	DIC
12	Florida	FLA
13	Georgia	GEO
15	Hawaii	HAW
16	Idaho	IDA
17	Illinois	ILL
18	Indiana	IND
19	Iowa	IOWA
20	Kansas	KAN
21	Kentucky	KEN
22	Louisiana	LIA
23	Maine	MNE
24	Maryland	MLD
25	Massachusetts	MASS
26	Michigan	MICH
27	Minnesota	MINN
28	Mississippi	MISS
29	Missouri	MO
30	Montana	MONT
31	Nebraska	NEB
32	Nevada	NEV
33	New Hampshire	N H
34	New Jersey	N J
35	New Mexico	N MEX
36	New York	N Y
37	North Carolina	N CAR
38	North Dakota	N DAK
39	Ohio	OHIO
40	Oklahoma	OKLA
41	Oregon	ORE
42	Pennsylvania	PENN
44	Rhode Island	RH IS
45	South Carolina	S CAR
46	South Dakota	S DAK

MAPHS SYSTEMS DOCUMENTATION MANUAL, NAVPERS 15,642

<u>Code</u>	<u>Country/State</u>	<u>Abbreviation</u>
47	Tennessee	TERN
48	Texas	TEX
49	Utah	UTAH
50	Vermont	VT
51	Virginia	VIR
53	Washington	WASH
54	West Virginia	W VA
55	Wisconsin	WISC
56	Wyoming	WYO
58	Other U.S. Possessions	--
99	Other Foreign Countries	--
ØØ	Unknown - This code will be utilized as a program default.	

- Note:
1. Codes Ø3, Ø7, 14, 43, and 52 are reserved for future use.
 2. Codes 58 and 99 are not DOD Standard, but are retained until no longer found in the Master File, due to attrition.

Chapter II
Part A
Section 1

Enlisted Data Element Dictionary

DOD AFEES

1. DEFINITION. A 3-position field which indicates the ARMED FORCES ENTRANCE EXAMINATION STATION that effected the member's enlistment.

2. REFERENCES.

a. NAVY RECRUITING MANUAL, COMNAVCRUITCOM INST 1130.8A

3. CODE STRUCTURE.

<u>Code</u>	<u>Description</u>
A01	Albany, NY
A02	Baltimore, MD
A03	Boston, MA
A04	Buffalo, NY
A05	Ft. Hamilton, NY
A06	Harrisburg, PA
A07	Manchester, NH
A08	Newark, NJ
A09	New Haven, CT
A10	Philadelphia, PA
A11	Pittsburgh, PA
A12	Portland, ME
A13	Springfield, MA
A14	Syracuse, NY
A15	Wilkes-Barre, PA
A20	Atlanta, Ga
A21	Beckley, WV
A22	Charlotte, NC
A23	Coral Gables, FL
A24	Pt. Jackson, SC
A25	Jacksonville, FL
A30	San Juan, P.R.
A31	Raleigh, NC
A32	Richmond, VA

MAPNIS SYSTEMS DOCUMENTATION MANUAL, NAVPERS 15,642

<u>Code</u>	<u>Description</u>
B26	Knoxville, TN
B27	Louisville, KY
B28	Montgomery, AL
B29	Nashville, TN
B42	Jackson, MS
B43	Kansas City, MO
B44	Little Rock, AR
B45	Memphis, TN
B46	New Orleans, LA
B49	Shreveport, LA
B54	Chicago, IL
B55	Cincinnati, OH
B56	Cleveland, OH
B57	Columbus, OH
B58	Des Moines, IA
B59	Detroit, MI
B60	Fargo, ND
B61	Indianapolis, IN
B62	Milwaukee, WI
B63	Minneapolis, MN
B64	Omaha, NE
B65	Sioux Falls, SD
B66	St. Louis, MO
C36	Albuquerque, NM
C37	Amarillo, TX
C38	Dallas, TX
C39	Denver, Co
C40	El Paso, TX
C41	Houston, TX
C47	Oklahoma City, OK
C48	San Antonio, TX
C70	Boise, ID
C71	Butte, MT
C72	Fresno, CA
C73	Honolulu, HI
C74	Los Angeles, CA
C75	Oakland, CA
C76	Phoenix, AZ
C77	Portland, OR
C78	Salt Lake City, UT
C79	Seattle, WA
C80	Spokane, WA
C82	Guam, M.I.
999	Unknown

Chapter II
Part A
Section 1

Enlisted Data Element Dictionary

SUCCESS CHANCES FOR RECRUITS ENTERING THE NAVY (SCREEN)

1. DEFINITION. A 3-position alphanumeric field which reflects a recruit's chances of successfully completing his initial tour of active duty. To be considered in establishing the score are AFQT Score, years education, age, and whether or not the member has dependents.

2. REFERENCES.

a. Navy Recruiting Manual, COMNAVCRUITCOMINST 113β.8

3. CODE STRUCTURE.

Code Description

Position 1 - Categories

A	Over 12 years education, no dependents (Majority)
B	Twelve years education, no dependents (Majority)
C	Over 12 years education, dependents (Majority)
D	Twelve years education, dependents (Majority)
E	Less than 12 years education, no dependents (Majority)
F	Less than 12 years education, dependents (Majority)
G	Over 12 years education, no dependents (Minority)
H	Twelve years education, no dependents (Minority)
J	Over 12 years education, dependents (Minority)
K	Twelve years education, dependents (Minority)
L	Less than 12 years education, no dependents (Minority)
M	Less than 12 years education, dependents (Minority)

Positions 2 & 3

(xx) a 2-position numeric score

Chapter II
Part A
Section 1

Enlisted Data Element Dictionary

ENLISTMENT EVALUATION TEST IDENTIFICATION (TESTID)

1. DEFINITION. A 2-position alpha-numeric code that identifies one of the particular test series administered to the recruit member:

- a. Basic Test Battery (BTE) - see MENTAL APTITUDE RESULTS.
- b. Armed Services Vocational Aptitude Battery (ASVAB) -- See MENTAL APTITUDE RESULTS.

2. REFERENCES.

- a. Navy Recruiting Manual, COMNAVCRUITCOMINST 1130.8
- b. Manual of Enlistment Classification Procedures, NAVPERS 15812
- c. BUPERS Manual, NAVPERS 15791

3. CODE STRUCTURE.

<u>Code</u>	<u>Description</u>
A5	ASVAB V
A6	ASVAB VI
A7	ASVAB VII
E2	BIB2
E4	EIB4
B5	EIE5
B7	EIE7
E8	EIE8
B9	BUPERS generate to identify records which contain test scores but have a blank test ID.

4. APPLICABLE TRANSACTIONS.

<u>Change Code</u>	<u>Description</u>
B29	Test Score
1FL	Navy-strength Gains (SCAT)

3. CODE STRUCTURE.

BASIC TEST BATTERY (ETE)

<u>ETE CODE</u>	<u>GCT</u>	<u>ARI</u>	<u>MECH</u>	<u>CLER</u>	<u>SHOP</u>	<u>ETST</u>		
B2	22-77	22-73	23-77	28-77	XX	XX	CI	22-76
E4	22-74	24-77	20-75	24-E3	XX	XX	CI	22-76
B5	22-72	22-74	20-77	28-79	XX	XX	CI	22-76
E7	22-75	25-69	22-75	28-73	22-74	XX	CI	22-76
B8	22-75	30-69	22-73	24-74	28-74	XX	CI	22-76

ARMED SERVICE VOCATIONAL APTITUDE BATTERY (ASVAB)

<u>Test</u>	<u>Score</u> <u>ASVAB 5</u>	<u>Range</u> <u>ASVAB 6</u>	<u>ASVAB 7</u>
GI	27-70	27-70	27-69
NC	27-66	27-69	27-68
AL	27-73	27-73	27-73
WK	27-69	27-68	27-68
AR	27-69	27-69	27-66
SP	27-68	27-73	27-70
MK	27-66	27-69	27-69
EI	27-73	27-73	27-73
MC	27-73	27-73	27-73
GS	27-73	27-73	27-73
SI	27-69	27-69	27-69
AI	27-70	27-69	27-69

4. APPLICABLE TRANSACTIONS.

<u>Change Code</u>	<u>Description</u>
B29	TEST SCORES
1PL	Navy-strength gain (SCAT)

SCHOOL HISTORY (SCHHIST1/2/3/4/5)

1. DEFINITION. Five 8-position numeric fields which are used to indicate significant formal Navy Training completed. All such training is included in the NAVY INTEGRATED TRAINING RESOURCES AND ADMINISTRATION SYSTEM (NITRAS), defined as any course two or more weeks in duration, or those courses for which an NEC is earned, regardless of duration. Each field consists of:

- a. Completion Date - Location 1166 (SCHHIST1/2/3/4/5DT)
- b. Course Code - Location 1170 (SCHHIST1/2/3/4/5CODE)

2. REFERENCES.

- a. Enlisted Transfer Manual, NAVPERS 15909
- b. CNETINST 1510.1

3. CODE STRUCTURE.

<u>Code</u>	<u>Description</u>
Completion Date (Pos. 1-4)	
(YRMO)	Year (2 pos.); Month (2 pos.)
Course Name (Pos. 5-8)	
(XXXX)	NITRAS School Course Code (see TRANSMAN for codes)

4. APPLICABLE TRANSACTIONS.

<u>Change Code</u>	<u>Description</u>
E38	Add School History
E45	School History, all five levels
QS1	NITRAS Transaction

5. UPDATE METHODS.

<u>Source</u>	<u>Mode</u>
NITRAS	a. Tape to the EMR update program
Pers-36121	a. Corrections via Cards

STUDENT ACTION CODE (5X2)

1. **DEFINITION.** Five 2-position alphanumeric fields which indicates member's graduation, or reason for non-graduation, of school/course identified by corresponding SCHOOL HISTORY COURSE CODE.

2. **REFERENCE.**

- a. TRANSMAN, figure 24a
- b. CNETINST 1510.1

3. **ITEM CODES.**

- a. NITRAS userman (NOTAL)

4. **CODE STRUCTURE**

- a. GRAD = 1*
- b. ACADEMIC ATTRITE CODES PAGE B-16a.
- c. NON-ACADEMIC ATTRITE CODES PAGE B-16b.

ANTICIPATED DISPOSITION

ACADEMIC ATTRIBUTES		REASSIGNED/ TRANSFERRED	DISCHARGED/ SEPARATED	RECLASSIFIED
CLASSROOM INABILITY	Lack of Fundamental knowledge/ prerequisite skills	AA	AB	AC
	Reading Deficiency	AD	AE	AF
	Math Deficiency	AG	AH	AJ
	Lack of Analytical Ability/Logic ..	AK	AL	AM
LABORATORY INABILITY	Lack of Fundamental knowledge/ prerequisite entry level skills	CA	CB	CC
	Lack of Manual Skills/Dexterity in use of tools & test equipment	CD	CE	CF
	Lack of Analytical Ability/Logic ..	CG	CH	CI
	Lack of Knowledge Application	CK	CL	CM
	Gross Violation of Safety Procedures	CR	CS	CT
	Other	EA	EB	EC

ACADEMIC ATTRIBUTES

ANTICIPATED DISPOSITION

NON-ACADEMIC ATTRIBUTES		REASSIGNED/ TRANSFERRED	DISCHARGED/ SEPARATED	RECLASSIFIED
MOTIVATION	Negative Navy/Military Attitude.....	GA	GB	GC
	Negative School/Training Attitude.....	GD	GE	GF
	Negative Attitude Toward This School/Course..	GG	GH	GI
	Learning Inability Attributed to a Documented Personal Problem.....	GK	GL	GM
	Not Mission Adapted or Oriented (Aero- nautically, Submarine, Diving, Explosive Ordnance Disposal, Special Warfare).....	GN	GO	QP
ELIGIBILITY REQUIREMENTS	Does Not Meet Physical Prerequisites for Service Field, Rating, or Speciality Training.....	JD	JE	JF
	Swimming Disqualification.....	JK	JL	JM
	Administrative Ineligibility for Course, School, or Service Field.....	JR	JS	JT
	Loss of Academic Eligibility for Nuclear or Advanced Electronics.....	JX	JY	JZ
DISCIPLINARY	Alleged Civil Crime.....	LD	LE	LF
	Alleged Military Crime.....	LG	LH	LJ
	Habitual Offender.....	LK	LL	LM
	Unauthorized Absence.....	LN	LP	LQ
	Declared Deserter.....			UR
ADMINISTRATIVE	Alcohol/Drug Rehabilitation.....	NA	NB	NC
	Rating or Program Conversion.....	ND		NE
	Fraudulent Enlistment.....		NL	
	Unsuitability.....		NP	
	Extreme Personal Hardship or Dependency..... Incomplete Training as Requested by Member's Command/Higher Authority.....	NX	NY	NZ
MEDICAL	Pregnancy.....	QA	QB	QC
	Psychological/Psychiatric.....	QD	QE	QF
	Became Physically Disqualified During Training.....	QG	QH	QJ
	Hospitalization.....	QK	QL	QM
	Other Medical Not Specified Above.....	QN	QP	QQ
	Death.....		SB	
	Other.....	ZA	ZB	ZC

NON-ACADEMIC ATTRIBUTES

STF-B-96-100
STF-B-113-115
STF-B-120

SCHOOL TYPE (5X1)
SCHOOL TYPE TDPG (3X1)
SCHOOL TYPE AVAIL (1)

1. **DEFINITION:** A 1-position field indicating whether the corresponding school course is an "A" school.

2. **STRUCTURE:**

1 - "A" school

Blank - Not "A" school

STF-B-101-104
STF-B-105-108
STF-B-109-112

**TEMPORARY DUTY PROSPECTIVE GAIN
(FIRST, SECOND, THIRD)**

FIRST TEMPORARY DUTY PROSPECTIVE GAIN SCHOOL COURSE CODE (TDPGI COURSE CODE - 1616). A 4- position numeric field that indicates a formal Navy school or course a member has been ordered to attend under the auspices of UNITRAS. This system includes schools for courses 2 or more weeks in duration, or those schools or courses for which a NEC is earned, regardless of duration.

STUDENT AVAILABILITY AREA (STUDENTAVAILAREA)

1. DEFINITION. 4-positions alphanumeric which indicate courses as a result of formal Navy training under the auspices of the NITRAS system.

a. STUDENT AVAILABILITY COURSE CODE (STUAVAIL COURSE) - 2280. A 4-position alphanumerical field which indicates a formal Navy school a member is attending under the auspices of NITRAS, which schools or courses are of two or more weeks in duration, or those schools or courses for which an NEC is earned, regardless of duration.

2. REFERENCES.

- a. Enlisted Transfer Manual, NAVPERS 15909
- b. Navy Enlisted Manpower and Personnel Classification and Occupational Standards - Section II, NAVPERS 18068
- c. CNET Instruction 1510.1 series

3. CODE STRUCTURE.

<u>Code</u>	<u>Description</u>
STUAVAIL COURSE	
(xxxx)	School Course Code

4. APPLICABLE TRANSACTIONS.

<u>Change Code</u>	<u>Description</u>
QDO	BUPERS controlled PG to PERMIC
QKO	COMPASS TAC
QMO	Modify Activity Assignment

5. UPDATE METHODS.

<u>Source</u>	<u>Mode</u>
Pers-51	a. Assignment/Order document b. Modifications to previous orders c. COMPASS transactions

6. REMARKS.

a. The student must not have a previously assigned ultimate duty station and must be available for assignment after completion of the current course.

APPENDIX C
STF UPDATE PROCESSING

STF UPDATE PROCESSING

The four computer programs used in updating the STF file are described in the following paragraphs. A copy of these programs is available on request from NAVPERS-RANDCEN, Code 15.

EMR Extract Program

This program creates an extract from the end-quarter EMR file. Most of the data elements in STF are taken directly from the EMR, while some are derived from EMR data elements (for details on specific elements and their derivation, see Appendix A). The output record contains data elements for both the STF-L and STF-B files. This extract is input to the STF update program.

Audit/Trail File Extract

This program creates two extracts from the audit/trail file. The first extract is based on audit/trail records with change codes "198" (cancel erroneous loss), "344" (SSN change), "8xx" (loss), and "9xx" (loss). The second extract is based on audit/trail records with change codes affecting either EAOS date. These include extensions, return from desertion, change of branch and class, etc. The first extract is input to the STF update program and serves to keep the STF accurate with respect to SSN changes, loss changes/cancellations, and gain cancellations. The second file is input to the STF merge program to determine reason for EAOS changes.

STF Update Program

This program combines the old STF-L, old STF-B, EMR extract, and audit/trail file extract to produce an intermediate step STF-L and STF-B and a file of SSN changes. The processing logic is described in the following steps:

1. All STF-L records with the same SSN are read and saved.
2. The STF-B record with the corresponding SSN is read.
3. The EMR extract record is read.
4. If the SSN on the EMR extract does not appear in the STF file, create new STF-L and STF-B records and write them to the intermediate files. Processing continues at step 3.
5. If the SSN on the old STF is not found on the EMR extract, the audit/trail extract is searched for change code "198" (cancel erroneous loss), "344" (SSN change), "996" (change loss reason), "998" (cancel erroneous gain), "8xx" (loss), or "9xx" (loss). If more than one of these codes are found, they are processed in chronological order. The STF file is modified accordingly. If the SSN has been modified, all of the STF records are written to the SSN change file.
6. If the SSN on the old STF matches the SSN of the EMR extract and the most recent STF record is not a loss (i.e., positions 111-120 are blank), the EMR record is appended to the STF-L record sequence. If the most recent STF record is a loss (i.e., positions 111-120 are not blank), the audit/trail extract is searched for possible amendment to STF loss record.

AD-A119 717

NAVY PERSONNEL RESEARCH AND DEVELOPMENT CENTER SAN D--ETC F/G 5/9
THE ENLISTED SURVIVAL TRACKING FILE (STF): A REVISION.(U)
SEP 82 K W GAY, J I BORACK
NPRDC-TN-82-27

UNCLASSIFIED

NL

2 of 2



END
DATE
AUTH.
1 1982
BY

7. Positions 15-24 of all records are set to the value of the EMR extract record.

8. If the contents of positions 24-120 in the last STF-L record match the contents of the corresponding positions in the EMR extract record, the quarter count (positions 13-14) in the last STF-L record is incremented. In this case, the EMR record is not included in the set of records written to the intermediate STF-L file. If the contents do not match, the EMR extract is included in the set of records written to the intermediate STF-L and STF-B files.

STF Merge Program

This program combines the intermediate STF-L file, the intermediate STF-B file, the SSN change file and the EAOS change reason file to produce the new STF-L and STF-B files. The SSN change records are appropriately inserted into both the STF-L and STF-B files. If either EAOS (positions 78-85) of the two most recent STF-L records differ, the EAOS change reason file is searched. If no record with the corresponding SSN is found, the EAOS change indicator (POS 86) in the most recent STF-L record is set to 9 (i.e., unknown reason). If a corresponding EAOS change is found, the indicator is set to the appropriate value. The STF-L records and the STF-B records are written to the new STF-L and STF-B files.

The STF update process is illustrated in Figure C-1.

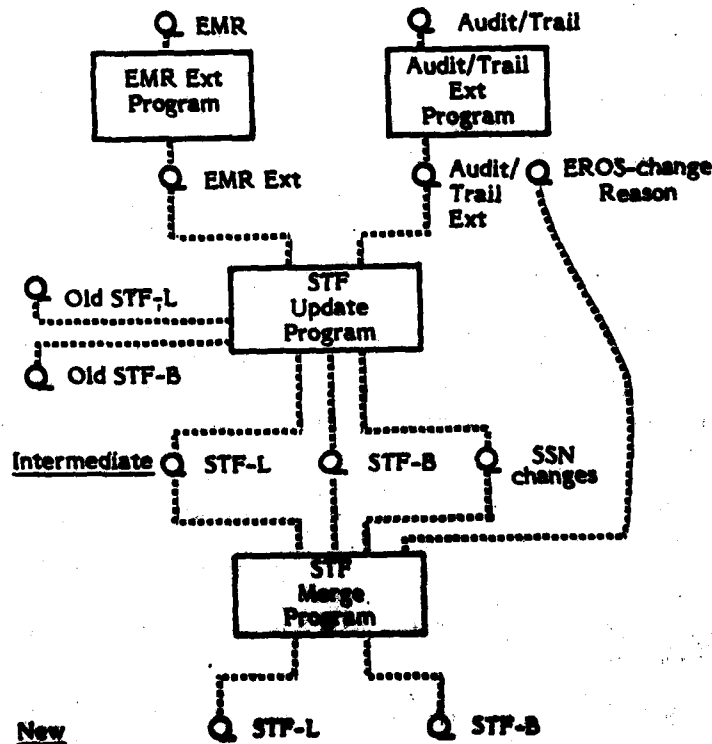

Figure C-1. Flowchart illustrating STF update processing.

DISTRIBUTION

Chief of Naval Operations (OP-11), (OP-12) (2), (OP-13), (OP-115) (2)

Chief of Naval Material (NMAT 05)

Commander Naval Military Personnel Command (NMPC-013C), (NMPC-164) (25)

Naval Postgraduate School, Department of Administrative Sciences (25)

Defense Technical Information Center (DDA) (12)