

AD A119770



2



1045 JONES BRANCH DRIVE McLEAN, VIRGINIA 22102 (703) 891-5000 TELETYPE 111581PM MCEN

Effectiveness of Mission Essential Maintenance Only (MEMO) During Transition to War

DTIC
COLLECTED
SEP 30 1982
D
H

PREPARED FOR THE DEPARTMENT OF THE ARMY, DEPUTY CHIEF OF STAFF
FOR LOGISTICS, MAINTENANCE POLICY (DALO-SMP)

DISTRIBUTION STATEMENT A
Approved for public release;
Distribution Unlimited

JUNE 16, 1982

BDM/W-82-313-TR



85

REPORT DOCUMENTATION PAGE		READ INSTRUCTIONS BEFORE COMPLETING FORM	
1. REPORT NUMBER BDM/W-82-313-TR	2. GOVT ACCESSION NO. A119 770	3. RECIPIENT'S CATALOG NUMBER	
4. TITLE (and Subtitle) Effectiveness of Mission Essential Maintenance Only (MEMO) during Transition to War		5. TYPE OF REPORT & PERIOD COVERED Final Study Report Jun 81 - Jan 82	
		6. PERFORMING ORG. REPORT NUMBER Same as 1	
7. AUTHOR(s) BDM Corporation		8. CONTRACT OR GRANT NUMBER(s) MDA 903-81-C-0411	
9. PERFORMING ORGANIZATION NAME AND ADDRESS BDM Corp, 7915 Jones Branch Drive, McLean, VA 22103 (703) 821-5000		10. PROGRAM ELEMENT, PROJECT, TASK AREA & WORK UNIT NUMBERS same as 1	
11. CONTROLLING OFFICE NAME AND ADDRESS HQDA (DALO-SMP) Washington, DC 20310		12. REPORT DATE June 16, 1982	
14. MONITORING AGENCY NAME & ADDRESS (if different from Controlling Office) Same as 11		13. NUMBER OF PAGES 201	
		15. SECURITY CLASS. (of this report) UNCLASSIFIED	
16. DISTRIBUTION STATEMENT (of this Report) Not limited to Department of the Army and other components of the Department of Defense A		15a. DECLASSIFICATION/DOWNGRADING SCHEDULE NA	
		17. DISTRIBUTION STATEMENT (of the abstract entered in Block 20, if different from Report) Unlimited	
18. SUPPLEMENTARY NOTES N/A			
19. KEY WORDS (Continue on reverse side if necessary and identify by block number) Logistics Mobilization Maintenance Deployed Forces Transportation ADP Manpower			
20. ABSTRACT (Continue on reverse side if necessary and identify by block number) Study focused on heavy present and 1986 era equipment to define impact of contingency maintenance standard on policies, procedures, doctrine in AR 750-1; determine impacts of transitioning to new standards, and impacts on turn around times/special controls. Central objective was to assess MEMO as one means of providing essential maintenance with a reduced strength maintenance force during the transition to war period.			

THE BDM CORPORATION

FOREWORD

This report is submitted to the US Army Deputy Chief of Staff for Logistics, Maintenance Policy (DALO-SMP) by The BDM Corporation, 7915 Jones Branch Drive, McLean, Virginia, 22102, in fulfillment of deliverable 0002AF of Contract MDA903-81-C-0411.

Accession For	
NTIS GRA&I	<input checked="" type="checkbox"/>
DTIC TAB	<input type="checkbox"/>
Unannounced	<input type="checkbox"/>
Justification for the	<i>(1-182) or file</i>
By	<i>file</i>
Distribution/	
Availability Codes	
Avail and/or	
Dist	Special.
<i>A</i>	



THE BDM CORPORATION

ACKNOWLEDGEMENTS

The authors wish to acknowledge the guidance and assistance provided by the personnel of the US Army Deputy Chief of Staff for Logistics, Maintenance Policy; the US Army Materiel Systems Analysis Activity; the US Army Ordnance School and the Army Study Advisory Group. The study benefited greatly from the active participation of LTC. David T. Morgan, Jr.; LTC. Joe P. Babb; LTC. Paul G. Bowers; and Dr. Wayne Copes who were instrumental in providing guidance and inputs that greatly enhanced the quality of the study.

THE BDM CORPORATION

LIST OF FIGURES

<u>Figure</u>		<u>Page</u>
I-1	Methodology Flowchart	I-3
I-2	Overview of Phase I Simulation Runs	I-5
II-1	Methodology Flowchart	II-5
II-2	Equipment Maintenance Analysis Methodology	II-6
III-1	MACATAK Model Configuration	III-4
III-2	Overview of Phase I Simulation Runs	III-10
III-3	M60A1 Operational Availability at ORG 01, Baseline Run	III-16
III-4	M813 Operational Availability at ORG 01, Baseline Run	III-17
III-5	M113A1 Operational Availability at ORG 01, Baseline Run	III-18
III-6	M813 Operational Availability at ORG 04, Baseline Run	III-19
III-7	M109A1 Operational Availability at ORG 04, Baseline Run	III-20
III-8	M113A1 Operational Availability at ORG 01, Baseline vs. MEMO	III-22
III-9	M109A1 Operational Availability at ORG 04, Baseline vs. MEMO	III-27
III-10	M60A1 Operational Availability at ORG 01, Baseline vs. MEMO	III-31
III-11	M60A1 Jobs Awaiting NSL Parts at FDS 01, Baseline vs. MEMO	III-35
III-12	M60A1 Jobs Awaiting DX Parts at RDS 01, Baseline vs. MEMO	III-36
III-13	M813 Operational Availability at ORG 01, Baseline vs. MEMO	III-38

THE BDM CORPORATION

LIST OF FIGURES (CONTINUED)

<u>Figure</u>		<u>Page</u>
III-14	M813 Operational Availability at ORG 04, Baseline vs. MEMO	III -39
III-15	Number of 63G Busy at FDS 01	III -45
III-16	Number of 63B Busy at RDS 01	III -48
III-17	Impacts of Deferred Maintenance - M113A1 at ORG 01	III -54
III-18	Impacts of Deferred Maintenance - M109 at ORG 01	III -56
III-19	Impacts of Deferred Maintenance - M60A1 at ORG 01	III -57
III-20	Impacts of Deferred Maintenance - M813 at ORG 01	III -59
III-21	M113A1 Jobs Awaiting NSL Parts at FDS 01	III -60
III-22	M109A1 Jobs Awaiting DX Parts at RDS 01	III -61
III-23	M813 Jobs Awaiting ASL Parts at RDS 01	III -62
III-24	M60A1 Jobs Awaiting NSL Parts at RDS 01	III -63
III-25	Number of 63H Busy at FDS 01	III -65
III-26	Number of 63G Busy at FDS 01	III -66
III-27	Number of 63B Busy at RDS 01	III -67
III-28	Number of 44B Busy at RDS 01	III -68
IV-1	Option 3 Simulation Run	IV-5
VII-1	RCM Decision Tree	VII-10
VII-2	Maintenance Action Essentiality Coding Methodology	VII-11

TABLE OF CONTENTS

<u>Chapter</u>		<u>Page</u>
	FOREWORD	iii
	ACKNOWLEDGEMENTS	iv
	TABLE OF CONTENTS	v
	LIST OF FIGURES	vii
	LIST OF TABLES	ix
I	EXECUTIVE SUMMARY	I-1 to I-20
	A. Introduction	I-1
	B. Methodology	I-2
	C. Phase I "H" Series Analyses	I-4
	D. Contingency Maintenance Standard	I-9
	E. Phase II (1986 Era) Analyses	I-11
	F. Phase III Tasks	I-13
	G. Summary of Findings and Observations	I-15
II	INTRODUCTION AND OVERVIEW	II-1 to II-12
	A. Background	II-1
	B. Current Efforts	II-1
	C. Simulation Overview	II-3
III	"H" SERIES EQUIPMENT ANALYSIS	III-1 to III-74
	A. Introduction	III-1
	B. Overview of Simulation Runs	III-9
	C. Analysis of Simulation Results	III-12
	D. Conclusions	III-70
IV	CONTINGENCY MAINTENANCE STANDARD	IV-1 to IV-15
	A. Introduction	IV-1
	B. Contingency Maintenance Standard Options	IV-1
	C. Comparison of Options	IV-12
	D. Selection of the Recommended Contingency Maintenance Standard	IV-14
V	1986 ERA EQUIPMENT ANALYSES (PHASE II)	V-1 to V-10
	A. Introduction	V-1
	B. 1986 Era Equipment Data Availability	V-2

THE BDM CORPORATION

TABLE OF CONTENTS (CONTINUED)

<u>Chapter</u>		<u>Page</u>
	C. Applicability of Phase I Findings	V-4
	D. Impacts of Modular Design	V-6
	E. Conclusions and Recommendations	V-10
VI	PHASE III TASKS	VI-1 to VI-10
	A. Introduction	VI-1
	B. Contingency Maintenance Standard Impacts on AR 750-1	VI-1
	C. Interfacing the Contingency Maintenance Standard with Present Maintenance Methods	VI-4
	D. Impacts of Operation in Other Theaters and Areas of Operations	VI-6
	E. Major Component and Assembly Usage	VI-7
VII	OBSERVATIONS	VII-1 to VII-13
	A. Purpose	VII-1
	B. Supply Policy	VII-1
	C. Manpower Authorizations	VII-5
	D. Equipment Authorizations	VII-6
	E. The 42 Series FMs	VII-6
	F. The Essentiality Coding Problem	VII-8
	G. Logistics Support Analysis Reports (LSAR)	VII-13
	H. Shotline Data	VII-13
VIII	SUMMARY AND APPLICATION OF STUDY RESULTS	VIII-1 to VIII-10
	A. Purpose	VIII-1
	B. Summary of Study Findings and Observations	VIII-1
	C. Application of Study Results	VIII-6
<u>Appendices</u>		<u>Page</u>
A	THE MACATAK MODEL	A-1 to A-23
B	CONTINGENCY MAINTENANCE STANDARD ADDITION TO AR 750-1	B-1 to B-2

THE BDM CORPORATION

LIST OF TABLES

<u>Table</u>		<u>Page</u>
I-1	Baseline Data Requirements	I-7
I-2	Summary of Options	I-12
III-1	MTDF Data Used by MACATAK	III-6
III-2	Attrition Data and Sources	III-8
III-3	Summary of Adjustments to OST's, Supply Policy, Equipment, and Manpower Authorizations	III -14
III-4	Summary of Average Operational Availability at D+120 (#OPNL/#AUTH)	III -15
III-5	Deferred Workload for the APC (Man-Hours)	III -23
III-6	Number of Jobs Received (APC)	III -23
III-7	Maintenance Turnaround Time (APC)	III -24
III-8	Queues for Parts and DX Items (APC)	III -24
III-9	Queues for Skills (APC)	III -26
III-10	Deferred Workload for the M-109 (Man-Hours)	III -26
III-11	Number of Jobs Received (M-109)	III -28
III-12	Maintenance Turnaround Time (M-109)	III -28
III-13	Queues for Parts and DX Items (M-109)	III -29
III-14	CMAC Summary M-60A1	III -30
III-15	Deferred Workload for the M-60A1 (Man-Hours)	III -32
III-16	Number of Jobs Received M-60A1	III -32
III-17	Maintenance Turnaround Times (M-60A1)	III -33
III-18	Queues for Parts and DX Items (M-60A1)	III-33

THE BDM CORPORATION

LIST OF TABLES (CONTINUED)

<u>Table</u>		<u>Page</u>
III-19	Jobs Waiting Men (M60A1)	III -34
III-20	Deferred Workload for the Truck (Man-Hours)	III -37
III-21	Number of Jobs Received (Truck)	III -40
III-22	Maintenance Turnaround Times (Truck)	III -40
III-23	Queues for Parts and DX Items (Truck)	III -41
III-24	Jobs Waiting Men (Truck)	III -40
III-25	MOSs Not Affected by MEMO	III -43
III-26	MOSs at FDS with Some Reduction in Manpower Achieved (D to D+120)	III -44
III-27	MOSs at RDS with No Improvement Under MEMO (D to D+120)	III -46
III-28	MOSs at RDS with Workload Reductions Under MEMO (D to D+120)	III -47
III-29	MOSs at GS Unaffected by MEMO (D + D+120)	III -49
III-30	MOSs at GS with Reduced Requirements Under MEMO (D + D+120)	III -50
III-31	Summary of Deferred Maintenance	III -52
III-32	MOSs at RDS with Large Work Backlogs (D + 121 to D + 180)	III -69
III-33	MOSs at GS with Large Work Backlogs	III -69
IV-1	Contingency Maintenance Standard Options	IV-2
IV-2	Average Operational Availability (Option 3 to Run 2)	IV-6
IV-3	Average Turnaround Times D to D+140 & D to D+120	IV-8
IV-4	Summary of Options	IV-15



7915 JONES BRANCH DRIVE · McLEAN, VIRGINIA 22102 · (703) 821-5000 · TELEX 901103BDM MCLN

EFFECTIVENESS OF MISSION
ESSENTIAL MAINTENANCY ONLY
(MEMO) DURING TRANSITION TO WAR
June 16, 1982

BDM/W-82-313-TR

DTIC
SELECTED
SEP 30 1982
S H

Prepared for the Department of the Army, Deputy Chief of Staff.
for Logistics, Maintenance Policy (DALO-SMP)

CHAPTER I
EXECUTIVE SUMMARY

A. INTRODUCTION

1. Background

During the past decade a number of studies and analyses have been conducted to determine how a peacetime force structure with its inherent shortfalls in manpower, can be rapidly and efficiently transitioned to war. These studies and analyses have attempted to assess the capabilities of the logistics system, organized, manned and equipped within peacetime constraints, to respond to the increased demands placed on it in a wide range of wartime operational settings. One of the primary objectives of these study efforts has been to accomplish required workloads while at the same time minimizing the shortfalls in logistics force structure. One method frequently offered has been to defer those maintenance actions that are not essential or that can be performed later in an operation without serious degradation of equipment performance. The Mission Essential Maintenance Only (MEMO) concept has been offered as one means of providing essential maintenance with a reduced strength maintenance force structure during the transition to war period.

2. Purpose and Objectives of the MEMO Study

The purpose of the MEMO study is to validate the MEMO concept and develop a contingency maintenance standard that will permit an efficient and effective transition from peace to war with the maintenance structure at reduced strength.

The primary objectives of the study are to:

- (1) Determine the validity of deferring nonessential maintenance.
- (2) Determine the contingency maintenance standard to be adopted during the transition period (120 days for the purpose of this study).
- (3) Determine the risks and trade-offs associated with adopting a deferred maintenance approach during the transition period.

THE BDM CORPORATION

Ultimately the results of the MEMO study will be used to recommend material stationing and force structure for maintenance units while transitioning from a peacetime to a wartime posture.

3. Study Approach

The study was divided into three phases. Phase I involved applying the MEMO concept as codified in the 42 series field manuals to selected "H" series equipment (M-60A1 tank, M-109A1 howitzer, M-113A1 armored personnel carrier and the M-813 5 ton truck) over the 120 day transition period. The Phase I analyses were aimed at validating the MEMO concept and developing a contingency maintenance standard to be applied during transition to war.

Phase II of the study involved an analysis of 1986 era equipment (M-1 tank, M-2 infantry fighting vehicle, M-3 cavalry fighting vehicle, M-901 improved TOW vehicle and the XM-987 multiple launch rocket system) to determine the applicability of the contingency standard to new equipment. Phase III of the study consisted of defining the impacts of the contingency maintenance standard on existing policies procedures and doctrine as stated in AR 750-1; determining the interfaces necessary to transition from the current maintenance standard to the contingency maintenance standard and back again upon attaining a mature maintenance posture; determining the impact of adopting the contingency maintenance standard in other theaters and contingency operations; and to assess the impacts of the contingency maintenance standard in such areas as major component and assemblies usage, transportation, maintenance turnaround time, and special controls.

B. METHODOLOGY

The BDM methodology diagrammed in Figure I-1, was developed and applied by a team of experienced logisticians familiar with maintenance, supply and transportation functions combined with a team of OR/SA professionals with vast experience in data collection, simulation and modeling,

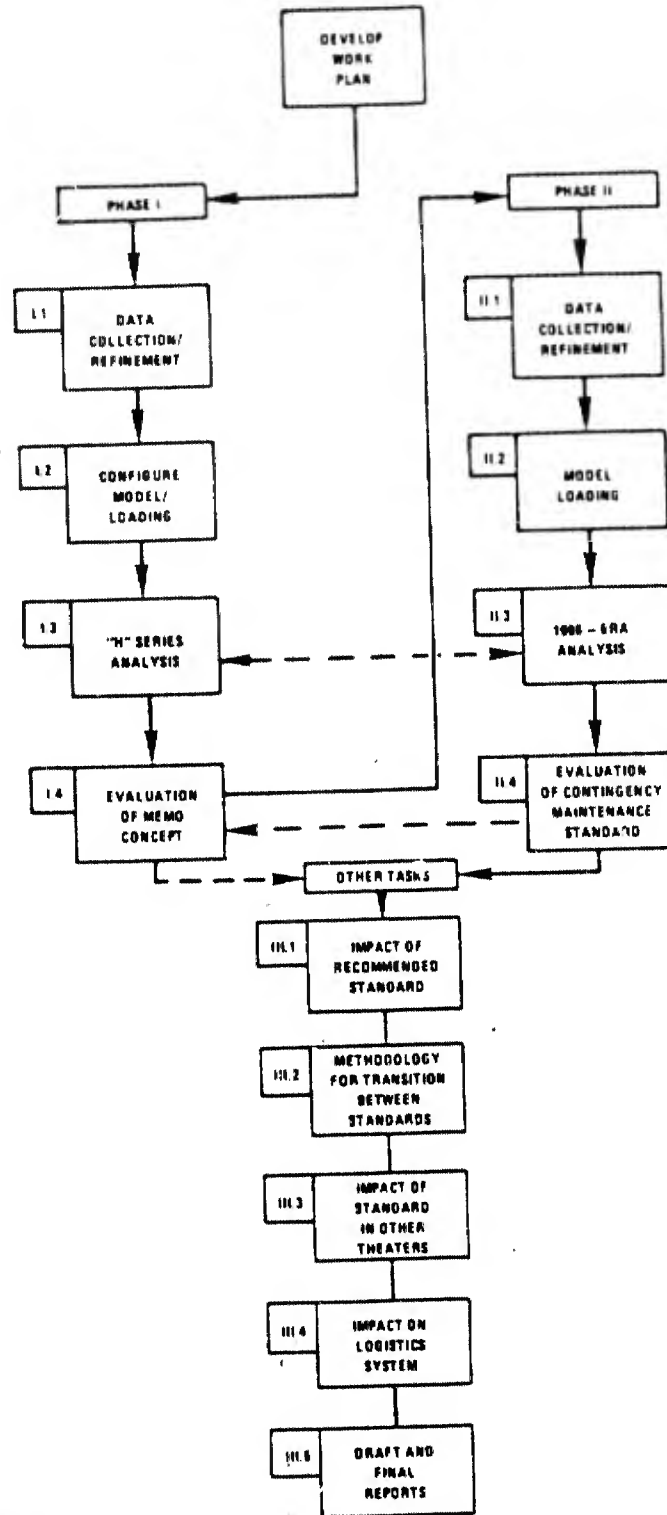

1099/B1W

Figure I-1. Methodology Flowchart

analyses and cost effectiveness evaluations. The methodology was specifically designed to accomplish all of the Phase I, II and III tasks and to accomplish the objections of the study.

The methodology included the use of the Maintenance Capabilities Attack (MACATAK) simulation model to analyze the application of the MEMO concept, as codified in the 42 series FMs, over the 120 day transition period, and to develop the contingency maintenance standard. MACATAK enabled the performance of the MEMO concept and the contingency maintenance standard to be observed over space and time and the impacts to be quantified in terms of operational availability of specific end items, utilization of individual MOSs, and requirements for authorized stockage list (ASL), non-stockage list (NSL) and reparable components and assemblies (these were treated as direct exchange (DX) items).

Detailed discussions of the methodology and technical approach are provided in Chapter III of this report. A detailed description of the MACATAK model is provided in Appendix A of the report. Detailed discussions of how the MACATAK model was employed and the results of the simulation runs are presented in Chapters III and VI of the report.

C. PHASE I "H" SERIES ANALYSES

The results of the Phase I analyses indicated that while the MEMO concept was valid, it must be applied incrementally and in conjunction with sound maintenance management if the desired results are to be achieved.

The conclusion is based on the results of the MACATAK simulation runs which measured the performance of the current maintenance system ("H" series) when required to maintain the M-60A1 tank, M-109 howitzer, M-113A1 armored personnel carrier and M-813 truck using first the current maintenance standard and then the MEMO concept over a 120 day transition period. Figure I-2 portrays the three simulation runs used in the analyses.

Run 1 established the baseline. It consisted of maintaining the selected end items under the current maintenance standard. During the first 120 days (D to D + 120) all maintenance actions were performed. The

PHASE I SIMULATION RUNS

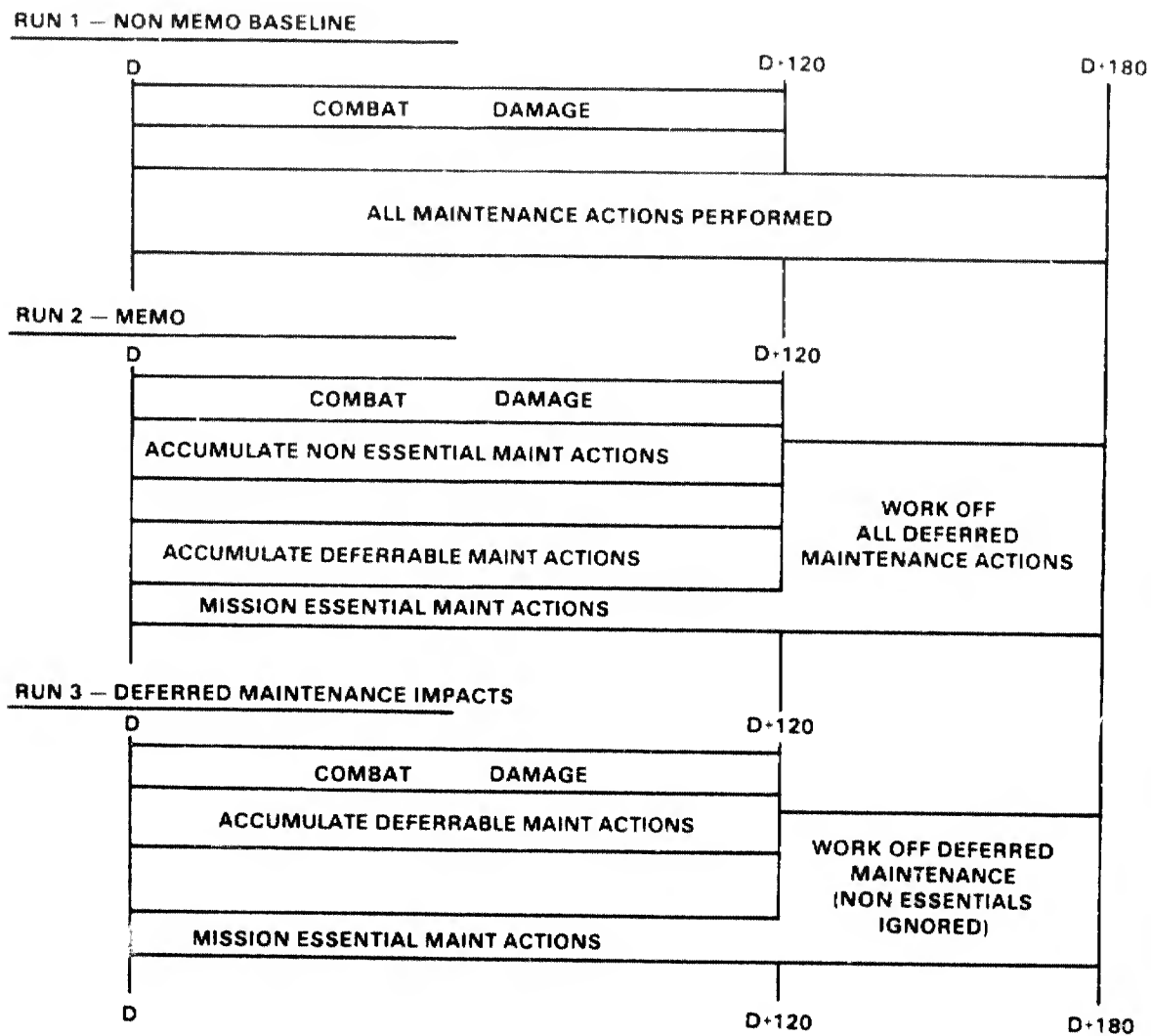

Figure I-2. Overview of Phase I Simulation Runs

maintenance workload consisted of normal maintenance failures plus combat damage. During the last 60 days of the run (D + 121 to D + 180) the maintenance system continued to perform all maintenance actions which consisted only of normal maintenance failures. Table I-1 provides a summary of input data required to conduct the simulation and the sources of the data. The input data is discussed in greater detail in Chapter III of this report.

During Run 2 the MEMO concept was applied on a continuous basis during the 120 day transition period (D to D + 120). The maintenance workload consisted of normal maintenance failures plus combat damage. However, during this 120 day period only mission essential maintenance actions were performed. All deferrable and nonessential maintenance actions were accumulated to be worked off during the last 60 days of the run, (D + 121 to D + 180). During the last 60 days of the run the maintenance workload consisted of normal maintenance failures plus all maintenance actions that were deferred during the D to D + 120 period.

Run 3 is essentially the same as Run 2 except that only deferrable maintenance actions were accumulated during the 120 day transition period and worked off during the D + 121 to D + 180 portion of the run. Non-essential maintenance actions were ignored.

In addition to the conclusion that the MEMO concept was valid if properly applied, analyses of the simulation results and the 42 series FMs indicated the following:

- (1) The need to maintain the 42 series manuals in addition to equipment technical manuals (TMs) could be eliminated by annotating the maintenance allocation charts (MACs) in the equipment TMs and incorporating the other 42 series FM data in the appropriate publication for the equipment. While the contingency maintenance allocation charts (CMACs) in the 42 series FMs can be used to annotate the MACs in equipment TMs, the 42 series FMs should be reviewed to insure that they are current and to eliminate discrepancies which are discussed in Chapter VII of this report.

TABLE I-7. BASELINE DATA REQUIREMENTS

<u>ELEMENT</u>	<u>DATA</u>	<u>SOURCE</u>
1. END ITEMS TO BE SUPPORTED	NOMENCLATURE & LINE NUMBER	SPECIFIED BY USER (MUST BE IN MTRF)
2. END ITEM SUPPORT PRIORITY	PRIORITY I THRU X	SPECIFIED BY USER
3. END ITEM USAGE INTENSITY	NUMERIC VALUE (0-1)	SPECIFIED BY USER
4. FLEET COMPOSITION	NUMBER OF EACH TYPE END ITEM BY NODE	- FORCE COMPOSITION - TOE AUTHORIZATION
5. NODE PRIORITY	NUMERIC VALUE (1-3) ORG, FDS, RDS	SPECIFIED BY USER
6. SKILLS	NUMBER OF INDIVIDUALS BY MOS AT FDS AND RDS NODES (SKILLS ARE NOT SIMULATED AT ORG AND GS NODES)	MAINT UNIT TOE
7. LIFT EQUIPMENT	NUMERIC VALUE AT FDS AND RDS NODES (LIFT EQUIPMENT IS NOT SIMULATED AT ORG AND GS NODES)	MAINT UNIT TOE
8. DIRECT EXCHANGE (DX) INVENTORY	INVENTORY OF LINE ITEMS	PRE-PROCESSOR BASED UPON AR710-2 CRITERIA OR ACTUAL UNIT INVENTORIES
9. PLL/ASL AND NSL AVAILABILITY THRESHOLD	PERCENTAGE (DEMAND SATISFACTION)	AR 710-2
10. ORDER-SHIP TIMES (OST) - PLL/ASL - NSL - MAJOR END ITEM	DELAY TIME - NUMERIC VALUE (DAYS BY NODE) - 00 - 00	SPECIFIED BY USER OR FROM DSS REPORTS 00 SPECIFIED BY USER
11. DIRECT EXCHANGE ITEM RESUPPLY - FROM DS TO ORG NODE - FROM SUPPLY SYSTEM TO DS NODES	DELAY TIME - NUMERIC VALUE (HOURS OR DAYS) - NUMERIC VALUE (DAYS BY NODE)	SPECIFIED BY USER USE PLL/ASL OST (ITEM 10)
12. NOTIFICATION TIME	DELAY TIME	SPECIFIED BY USER
13. RECOVERY TIME	DELAY TIME	SPECIFIED BY USER OR OC&S BATTLEFIELD RECOVERY MODEL DATA
14. CONTACT TEAM TRAVEL TIME	DELAY TIME (BY NODE)	SPECIFIED BY USER BASED UPON TRAVEL DISTANCE
15. EVACUATION TIME	DELAY TIME	SPECIFIED BY USER BASED UPON TRAVEL DISTANCE AND AVAILABILITY OF TRANSPORT

- (2) Continuous application of the MEMO concept over extended periods of time (in this case 120 days) will result in the accumulation of deferred maintenance backlogs that will overwhelm the maintenance system. MEMO application periods should be limited to 15 to 20 days.
- (3) Various types of equipment will react differently to the application of the MEMO concept. Those which will react most favorably will have the greatest deferred maintenance workload at the organizational and forward direct support levels. The deferred maintenance workload is a function of not only the number of deferred maintenance actions but also their frequency of occurrence.
- (4) The application of the MEMO concept will not effect all MOS's uniformly. Some MOSs will experience reductions in workloads during the periods in which MEMO is applied, while others will experience little if any reductions.
- (5) The application of the MEMO concept will not result in any substantial reductions in requirements for repair parts and DX items. In fact, requirements may increase since parts will be required for deferred maintenance actions plus additional mission essential actions that may be performed by MOSs freed from deferred and nonessential tasks.
- (6) Any reductions in requirements for repair parts and DX items should not be viewed as savings since these parts and MOSs will be required to perform the deferred maintenance actions when they are worked off.
- (7) While reductions of workloads were realized for some MOS's during MEMO application periods, these reductions were offset by corresponding increases in workloads for the same MOS's when deferred maintenance backlogs were worked off.

These findings, supported by tabular statistics and graphs produced by the simulation runs provided the foundations for constructing alternative contingency maintenance standards.

D. CONTINGENCY MAINTENANCE STANDARD

1. Alternatives Developed

During the course of the Phase I analyses, five alternative contingency maintenance standards were considered. The first alternative was to retain the current maintenance standard if the MEMO concept proved to be invalid. The second alternative was the continuous application of the MEMO concept, as codified in the 42 series FMs. The third alternative was developed by analyzing simulations of the first alternative (baseline Run 1) and the second alternative (MEMO Runs 2 and 3). The third alternative was then simulated and the results analyzed to develop alternatives four and five.

2. Summary and Advantages of Alternatives

a. Summary

Each of the five alternative contingency maintenance standards considered are summarized below:

1) Alternative 1 (Current Maintenance Standard)

All maintenance actions are accomplished as they occur and as maintenance resources are available, without consideration to the essentiality of maintenance actions.

2) Alternative 2 (42 Series FM MEMO Standard)

Only mission essential maintenance actions are accomplished during the 120 day transition period. All deferrable maintenance actions are accumulated and accomplished at the end of the 120 day transition period.

3) Alternative 3 (Incremental MEMO Application Standard)

The MEMO concept is applied incrementally throughout the 120 day transition period, with MEMO application periods not exceeding 15 to 20 days. During the MEMO application periods only mission essential maintenance actions are performed. Deferrable maintenance actions are accumulated and accomplished in between the MEMO application periods.

4) Alternative 4 (Incremental MEMO and Management Application Standard)

Alternative 4 is essentially the same as Alternative 3 except that maintenance management is included at each level of maintenance. The role of the manager is to insure that maintenance resources focus on those items of equipment that can be most rapidly repaired and returned to the operational fleet. Other more extensively damaged items are evacuated to the next level of repair.

5) Alternative 5 (Selected Item Application and Management Standard)

Alternative 5 resembles Alternative 4; however, maintenance efforts are focused on the repair of selected major end items most required to meet operational needs, and the role of the maintenance managers is significantly increased.

The MEMO concept is applied incrementally throughout the 120 day transition period, with MEMO application periods not exceeding 15 to 20 days. During the MEMO application periods, first priority is given to the performance of mission essential maintenance actions. Deferable maintenance actions are also accomplished during MEMO application periods if required maintenance resources and time are available. Deferred maintenance backlogs are accomplished between the MEMO application periods. Maintenance resources are focused on those items of equipment that can be most rapidly repaired and returned to service. Other more extensively damaged items are evacuated to the next level of maintenance depending on that level's capacity and backlog. Available MOSs can be shifted from their specialty to related areas where they can be more effectively used to meet operational needs. This includes shifting from component repair to repair of end items by replacement of faulty components. Higher level maintenance units can also form and deploy maintenance augmentation packages to lower levels--particularly the organizational and forward direct support level to increase the capabilities to repair major end items by replacing faulty components. These augmentation packages consist of maintenance personnel accompanied by tools, parts and DX items necessary to accomplish required repairs.

The role of the maintenance manager includes recommending priorities of equipment to be repaired, managing MEMO applications and workloads at his level and coordinating evacuation and augmentation requirements with his supporting maintenance manager. Additionally, maintenance managers at levels where component repair is accomplished will be required to determine essentiality of component repair based upon demand and availability. In this alternative the only essentiality coded maintenance actions in MACs are those maintenance actions which repair the major end item. Essentiality codes of maintenance actions for repair of components is determined on a day to day basis and is based upon demand and availability.

b. Advantages

The advantages and disadvantages of each alternative are discussed in Chapter IV. They are summarized in Table I-2.

c. Recommended Alternative

Based upon the advantages and disadvantages of each alternative, Alternative 5 appears to be the best alternative for the contingency maintenance standard.

E. PHASE II (1986 ERA) ANALYSES

The results of Phase II analyses indicated that the recommended contingency maintenance standard (Alternative 5) could be successfully applied to the 1986 era equipment. This conclusion was based upon analyses of available Logistic Support Analysis Reports (LSAR) for the M-1 tank, M-2 IFV, M-3 CFV, M-901 ITV and SM-987 MLRS, and discussions with personnel from project manager offices and experienced maintenance personnel from the US Army Ordnance Center and School, Aberdeen, Maryland.

Analyses also indicated that 1986 era equipment would respond to the application of the contingency maintenance standard in much the same manner as current, "H series" equipment.

- (1) Various types of equipment will react differently, depending upon where the greatest deferred maintenance workload actually occurs;

TABLE I-2. SUMMARY OF OPTIONS

CRITERIA	OPTIONS				
	1	2	3	4	5
1. INCREASES OPERATIONAL AVAILABILITY OVER CURRENT STANDARD	N/A	YES	YES	YES	YES
2. PRECLUDES UNACCEPTABLE DEFERRED MAINT. BACKLOGS	YES	NO	YES	YES	YES
3. PRECLUDES UNMANAGEABLE SURGE REQUIREMENTS FOR SKILLS AND PARTS	YES	NO	YES	YES	YES
4. PRECLUDES UNMANAGEABLE ACCUMULATION OF PARTS FOR DEFERRED MAINT. ACTIONS	YES	NO	YES	YES	YES
5. MINIMIZES INCREASED FAILURE RATES STEMMING FROM DEFERRING MAINT.	YES	NO	YES	YES	YES
6. INCORPORATES PROVEN MANAGEMENT TECHNIQUES					
a. AT EACH LEVEL	NO	NO	PARTIAL	YES	YES
b. FOR TOTAL SYSTEM	PARTIAL	NO	NO	NO	YES
7. CONSIDERS REPAIR OF END ITEMS AND REPAIR OF REPARABLES	NO	NO	NO	NO	YES

- (2) Not all MOSs will be effected uniformly;
- (3) No substantial savings in repair parts and DX items will occur; and
- (4) Any decreases in manpower or parts utilization during periods when the contingency maintenance standard is applied will result in corresponding increases necessary to accomplish deferred maintenance backlogs.

During both the Phase I and Phase II analyses it was determined that the MEMO concept and contingency maintenance standard could be implemented without significant change to the current and 1986 era maintenance systems. However, analysis of the 1986 equipment indicated that the modular design of new equipment may require significant changes in the functions of direct and general support maintenance. Specifically, the increased volume of reparable components and assemblies on new equipment may require that component repair capabilities at the direct support level be replaced by increased (DX) supply capabilities, and that component repair be centralized at the general support level. This is discussed in greater detail in Chapter V.

F. PHASE III TASKS

The Phase III analyses focused on four tasks: the impacts of the contingency maintenance standard on current policies, procedures and doctrine; means of interfacing with current maintenance methods; the impacts of adopting the contingency maintenance standard in other theaters; and the impacts of the contingency maintenance standard on the logistics systems. Findings in each of these areas are summarized below. Detailed discussions are provided in Chapter VI.

1. Impacts on Current Policies, Procedures and Doctrine

AR 750-1 was reviewed to determine the impacts of the contingency maintenance standard on current maintenance policies, procedures and doctrine. It was determined that provisions required to provide for implementation of the contingency maintenance standard included relatively minor

changes to the current regulation. The changes which include the addition of a chapter on the MEMO concept are outlined in Chapter VI. They are aimed primarily at recognizing the contingency maintenance standard as approved doctrine, outlining when it is to be employed, and addressing other actions necessary for its implementation.

The new chapter that is recommended is outlined in Appendix B. It is oriented toward providing a clear definition of the contingency maintenance standard and how it should be implemented.

2. Interface

The key to providing the interface between the current maintenance standard and the contingency maintenance standard is to provide maintenance managers and repairmen the necessary guidance and management tools. This can be accomplished by incorporating the recommended changes into AR 750-1 and providing annotated MACs in the TMs for each vehicle.

3. Application in Other Theaters and Contingencies

a. Other Theaters

Analyses determined that the contingency maintenance standard is as applicable to one theater as another. Workloads can be expected to vary from one theater to another, but these variations are not attributable to nor do they effect the contingency maintenance standard. Variations will be caused by the combination of threat, climate and topography. Threat and topography may cause the frequency of some maintenance actions to increase. Climate may also cause changes in workloads. For example personnel heaters will become mission essential in arctic climates. These variations may require changes in TOE authorizations for the effected MOSs.

b. Other Contingencies

Analyses determined that the contingency maintenance standard could be applied during other contingency operations, but would not replace the need for sound logistics planning. Tailoring of maintenance units to support force packages would require that consideration be given to providing adequate logistics resources to accomplish the repair of major

end items and that provisions be made for either repairing reparable components or providing additional stockage levels to meet operational needs.

4. Impacts on Logistics Systems

The contingency maintenance standard was specifically designed to minimize surge requirements for repair parts and replacement components and assemblies. The two major factors that may influence requirements for increased stockage of parts, components and assemblies are the modular design of new equipment and the deployment of contingency force packages and logistics support packages which replace component and assembly repair capabilities with increased levels of stock.

G. SUMMARY OF FINDINGS AND OBSERVATIONS

1. Background

The study effort was designed and conducted to answer the questions contained in the contract statement of work (RFP Number MDA903-81-R-0067). The major findings summarized in paragraph 2 below address these questions. During the course of the study several observations were also made in areas related to the study. These observations provide insights into a number of supply and maintenance problem areas which ultimately effect the ability of the maintenance system to respond to operational needs during the transition period and during combat operations. While some of the observations provide insights as to courses of action that should be taken by the Army, others identify areas where further analyses are necessary. The observations summarized in paragraph 3 below are discussed in greater detail in Chapter VII.

2. Findings

a. Validity of the MEMO Concept

The MEMO concept is valid if applied incrementally and in conjunction with proven maintenance management procedures. Continuous application of the MEMO concept (as codified in the 42 series FMs) throughout the 120 day transition period will result in deferred maintenance backlogs that overwhelm the maintenance and supply systems.

b. Man-hour Costs

When compared to the current maintenance standard, the application of the MEMO concept, as codified in the 42 series FMs and the contingency maintenance standard, results in reduced maintenance workloads. However, these reduced man-hour requirements do not occur uniformly for all MOSs. Furthermore, these reductions should not be viewed as savings in the context that TOE authorizations can be reduced or that shortages are acceptable. First, the hours saved by deferring deferrable maintenance actions will most likely be used to perform additional mission essential actions. Second, the MOS's will be required to accomplish the deferred maintenance backlogs.

c. Material Costs

When compared to the current maintenance standard, the application of the MEMO concept as codified in the 42 series FMs and the contingency maintenance standard does not result in a reduction of requirements for repair parts and reparable components and assemblies. First of all the repair parts and reparable components and assemblies for deferred maintenance actions are required to accomplish deferred maintenance backlogs. Secondly, additional repair parts and reparables will most likely be required to accomplish the increased number of mission essential maintenance actions that can be performed as a result of deferring other actions.

d. Recommended Contingency Maintenance Standard

Alternative 5 provides the best combination of proven maintenance management techniques and MEMO concept application. The alternative is applicable to "H" series and 1986 era equipment, permits realization of MEMO concept potentials, and is the most responsive to operational needs.

e. Policy, Procedural, and Doctrinal Impacts

The recommended contingency maintenance standard has minimal impact on current maintenance policies, procedures and doctrine. Initial provisions for implementation of the contingency maintenance standard can

be accomplished by relatively minor changes to AR 750-1 and supporting documents.

f. Interfaces

Ease of interface with current maintenance methods was a key consideration in the development of the recommended contingency maintenance standard. Incorporating recommended changes to AR 750-1, emphasizing the need for sound maintenance management and providing annotated MACs will provide the guidance and management tools necessary for interface.

g. Operations in Other Theaters

Operations in other theaters such as Korea, and Southwest Asia and the conduct of other contingency operations do not effect the application of the recommended contingency maintenance standard. Variations in workloads attributable to different threats, climates, and topographies can be expected, but are independent from the recommended contingency maintenance standard.

h. Impacts on Logistics Systems

The implementation of the recommended contingency maintenance standard will have little impact on the logistics systems. Tailoring of logistics support packages for contingency operations can necessitate that stockage levels of repair parts, components and assemblies and unit carrying capacities be increased when component and assembly repair capabilities are not deployed. Modularization may also necessitate increased stockage levels of reparable particularly at the direct support level and the centralization of component and assembly repair at the general support level. However, neither tailoring nor restructuring of direct and general support functions are attributable to the recommended contingency maintenance standard.

3. Observations

a. Retention of the 42 Series FMs

The need to maintain the 42 Series FMs can be eliminated by annotating the MACs in current equipment TMs and incorporating the other contents of the 42 series FMs into other appropriate maintenance publications. While the 42 series FMs can be used to annotate MACs, the 42 series

FMs should be thoroughly reviewed to insure that they are current and to eliminate discrepancies.

b. Stockage Policy

Current add-retain criteria in AR 710-2 combined with the formula used to calculate authorized stockage levels results in the breadth and depth of stockage in peacetime that appears to be substantially less than the levels required to support wartime operations. These shortfalls may far exceed the capabilities of the supply system and industry to meet surge demands that may occur during transition and war. Current efforts to allow stockage of non-demand supported combat ASL/PLL within a limit of 300 line items do not appear to be adequate.

c. NSL

During transition to war and war, many NSL items will become ASL due to increased equipment utilization, combat damage and corresponding increased demands. This will pose a serious problem in overseas theaters in which NSL items are not stocked. Current efforts to allow stockage of non-demand supported items may not be adequate.

d. Unit Equipment Authorizations

Units may not be authorized sufficient equipment to support required maintenance operations. Shortages of lift equipment caused significant queues during initial attempts to simulate the current maintenance system. Units may also require substantial increases in trucks and vans for repair parts as stockage levels must be increased to support wartime operations.

e. Unit Personnel Authorizations

Units do not appear to be properly organized for prolonged 24-hour operations. Shortages of some MOSs were experienced during initial attempts to simulate the current maintenance system. Increased authorizations should also be considered for some critical MOSs to provide the maintenance system the depth, redundancies and resilience required to meet wartime demands and insure system survivability.

f. Essentiality Coding of Reparable Repair actions

Maintenance actions for the repair of reparable should not be assigned essentiality codes in MACs. The essentiality of repairing reparable should be determined by maintenance managers on a day to day basis, based upon demands and availability of reparable in the supply and maintenance systems. Maintenance actions assigned essentiality codes in MACs should be limited to those which involve repair and return of the major end item to service.

g. Essentiality Coding Methodology

The decision tree logic used in the DOD Reliability Centered Maintenance (RCM) program offers the disciplined approach required to determine essentiality codes for maintenance actions. This methodology should be applied when determining essentiality codes for maintenance of new equipment and should be used to verify the essentiality codes contained in the 42 series FM CMACs. The Army should consider taking the steps necessary to formalize the use of this methodology and to begin its application.

h. Essentiality Codes

The designation of some maintenance actions as "NONESSENTIAL" raises serious questions as to whether the component or assembly to which they pertain should have been included in the equipment design and procurement. At the same time, peacetime safety items were not identified as such.

i. Logistics Support Analysis Reports (LSAR)

The LSAR appears to offer the Army considerable potential for analyzing equipment, maintenance support concepts and for validating TOE and parts requirements. There does not appear to be a procedure for maintaining, updating or fully utilizing the LSAR data.

j. The Maintenance Task Demand File (MTDF)

The MTDF provides a format compatible with the LSAR and has proven a useful tool in analyzing maintenance problems. It appears that a procedure to use LSAR data for new and product improved equipment to expand

the MTFD and a procedure to update the MTFD would provide a valuable analytic tool to the Army.

k. Hotline Data

The hotline data currently developed by AMSAA and BRL could be more widely used if a standard format existed. The MTFD appears to be the logical candidate.

CHAPTER II
INTRODUCTION AND OVERVIEW

A. BACKGROUND

Traditionally, maintenance has been defined as all actions taken to retain materiel in a serviceable condition or to restore it to serviceability. The proliferation of increasingly sophisticated equipment in the armed services has created a corresponding increase in maintenance workload. This increased maintenance workload requires additional expenditure of manpower and material resources to achieve the desired equipment operational availability rates. The maintenance problem is further complicated during the transition to war by the need to meet operational requirements in compressed time with reduced manpower resources. Thus, the services, particularly the Army, have been forced to take a second look at the traditional maintenance definitions and concepts in search of ways to reduce maintenance manpower requirements while retaining a relatively high availability.

B. CURRENT EFFORTS

A number of studies and analyses have been initiated with the purpose of determining how a peacetime force structure can be rapidly and efficiently transitioned to war. These studies have attempted to assess the Army's capability versus requirements in various operational settings. Each has recommended a variety of ways the expected force structure shortfall could be minimized. One method frequently offered is that of deferring nonessential maintenance. The Mission Essential Maintenance Only (MEMO) concept has been offered as a means of providing essential maintenance without the full cost of a maintenance force structure for the transition to war.

The MEMO concept is designed to reduce the required maintenance workload. This reduction would be achieved by performing only the mission

THE BDM CORPORATION

essential maintenance actions, postponing deferrable maintenance actions, and not performing at all non-mission essential ones. In the concept, mission essential maintenance tasks are those essential in terms of mission accomplishment or safety of personnel and equipment. Deferrable actions are those that can be deferred for a specified period of time, for example, 120 days. Nonmission essential actions are those not essential in terms of mission accomplishment or safety of personnel or equipment.

To some extent, the MEMO concept formalizes the procedure used by many units during World War II and the Korean and Vietnam conflicts. During these conflicts, seldom, if ever, were trucks deadlined for lack of canvas, damaged tailgates, torn seats, or even cracked windshields. As long as the vehicle was capable of performing its primary mission, it was retained in operational status and the maintenance was deferred until the mechanics, parts, and time became available.

A prima facie examination of the MEMO concept appears to disclose that the concept is highly desirable and operationally effective in its utilization of available maintenance resources. By performing only the mission essential maintenance actions, the available manpower can be used more effectively and a higher equipment availability rate can be maintained.

1. Results

The MEMO concept has been codified in FM 42 series field manuals for selected items of Army equipment. The methodology and results documented in those manuals have not been validated for use in present contingency planning. Other study efforts related to maintenance, in general, and MEMO, in particular include Air Line of Communication (ALOC); Total Army Analysis (TAA)-86; FM 101-10-1 Staff Officers' Field Manual; Battlefield Recovery and Evacuation (BRE) Study; Administrative and Logistics System Program Review (ALSPR); Sustainability Predictions for Army Spare Component Requirement for Combat (SPARC); Maintenance Standards Study; Positive Challenge (PC); Manpower Authorization Criteria (MACRIT); Force Analysis Simulation of Theater Administrative and Logistical Support (FASTALS); Concepts Evaluation Model (CEM); the Combat-to-Support Balance Study (CSBS); and the Minimum Essential US Ground Forces Support Unit

CHAPTER II
INTRODUCTION AND OVERVIEW

A. BACKGROUND

Traditionally, maintenance has been defined as all actions taken to retain materiel in a serviceable condition or to restore it to serviceability. The proliferation of increasingly sophisticated equipment in the armed services has created a corresponding increase in maintenance workload. This increased maintenance workload requires additional expenditure of manpower and material resources to achieve the desired equipment operational availability rates. The maintenance problem is further complicated during the transition to war by the need to meet operational requirements in compressed time with reduced manpower resources. Thus, the services, particularly the Army, have been forced to take a second look at the traditional maintenance definitions and concepts in search of ways to reduce maintenance manpower requirements while retaining a relatively high availability.

B. CURRENT EFFORTS

A number of studies and analyses have been initiated with the purpose of determining how a peacetime force structure can be rapidly and efficiently transitioned to war. These studies have attempted to assess the Army's capability versus requirements in various operational settings. Each has recommended a variety of ways the expected force structure shortfall could be minimized. One method frequently offered is that of deferring nonessential maintenance. The Mission Essential Maintenance Only (MEMO) concept has been offered as a means of providing essential maintenance without the full cost of a maintenance force structure for the transition to war.

The MEMO concept is designed to reduce the required maintenance workload. This reduction would be achieved by performing only the mission

THE BDM CORPORATION

essential maintenance actions, postponing deferrable maintenance actions, and not performing at all non-mission essential ones. In the concept, mission essential maintenance tasks are those essential in terms of mission accomplishment or safety of personnel and equipment. Deferrable actions are those that can be deferred for a specified period of time, for example, 120 days. Nonmission essential actions are those not essential in terms of mission accomplishment or safety of personnel or equipment.

To some extent, the MEMO concept formalizes the procedure used by many units during World War II and the Korean and Vietnam conflicts. During these conflicts, seldom, if ever, were trucks deadlined for lack of canvas, damaged tailgates, torn seats, or even cracked windshields. As long as the vehicle was capable of performing its primary mission, it was retained in operational status and the maintenance was deferred until the mechanics, parts, and time became available.

A prima facie examination of the MEMO concept appears to disclose that the concept is highly desirable and operationally effective in its utilization of available maintenance resources. By performing only the mission essential maintenance actions, the available manpower can be used more effectively and a higher equipment availability rate can be maintained.

1. Results

The MEMO concept has been codified in FM 42 series field manuals for selected items of Army equipment. The methodology and results documented in those manuals have not been validated for use in present contingency planning. Other study efforts related to maintenance, in general, and MEMO, in particular include Air Line of Communication (ALOC); Total Army Analysis (TAA)-86; FM 101-10-1 Staff Officers' Field Manual; Battlefield Recovery and Evacuation (BRE) Study; Administrative and Logistics System Program Review (ALSPR); Sustainability Predictions for Army Spare Component Requirement for Combat (SPARC); Maintenance Standards Study; Positive Challenge (PC); Manpower Authorization Criteria (MACRIT); Force Analysis Simulation of Theater Administrative and Logistical Support (FASTALS); Concepts Evaluation Model (CEM); the Combat-to-Support Balance Study (CSBS); and the Minimum Essential US Ground Forces Support Unit

THE BDM CORPORATION

Requirements for the First 30 Days of War in Europe Study. It is expected that the study of maintenance concepts will necessitate concurrent examination of the supply and transportation processes which directly support that maintenance.

2. Actions

The MEMO concept has been offered as a means of providing essential maintenance without the full cost of a maintenance force structure for the transition to war. Validation of this concept is essential before the Army can name appropriate refinements in maintenance policy force structures and material stationing.

The ultimate use of the MEMO study results will be to develop the recommended material stationing and force structure for maintenance units while transitioning to a wartime footing. Specific objectives of the study are:

- (1) To determine the validity of deferring nonessential maintenance The MEMO (Mission Essential Maintenance Only) Concept.
- (2) To determine the maintenance standard to be adopted during the transition to war period.
- (3) To determine the risks and trade-offs associated with adopting a deferred maintenance approach during the transition to war period.

C. SIMULATION OVERVIEW

1. Introduction

Determining the validity of the MEMO concept essentially consisted of performing a comparative evaluation between the MEMO concept and the present maintenance standards. Some of the numerous key issues and questions answered by such an evaluation include:

- (1) What will happen when the deferred maintenance becomes due-- will it then overwhelm the maintenance system?
- (2) What will be the condition of the equipment after 120 days under the MEMO concept--will it be economically repairable?

THE BDM CORPORATION

- (3) Is the current mix of maintenance skills in the units compatible with the MEMO concept or will certain skills be in excess and others short?
- (4) Will the anticipated gains in maintenance capability under the MEMO concept be real, or will these gains fail to materialize due to shortages in the Class IX supply and transportation system?

In addition, the study will:

- (1) Determine and define the impact that the recommended contingency maintenance standard will have on existing policies, procedures, and doctrine (AR 750-1);
- (2) Determine the best means of interfacing with present maintenance methods;
- (3) Determine the impact of adopting the contingency maintenance standard in Korea, Southwest Asia, and contingency operations; and,
- (4) Assess the impact on the logistics systems in such areas as major component and assemblies usage, transportation of these items, turn around time, and special controls needed.

2. Technical Approach

The original approach to this study is portrayed in Figure II-1. Task I.1 and I.2 were organized to provide the information and simulation model configuration and basic data required to support the "H" series analyses in Task I.3. Figure II-2 shows the breakout of Task I.3. The analysis in Task I.3 was made using the Maintenance Capabilities Attack (MACATAK) simulation model to assist in forecasting damage and failure workloads (Subtask I.3.1), and to produce quantitative data by simulating the current standard (Subtasks I.3.2 and I.3.3) and MEMO applications (Subtask I.3.4). The results of Subtasks I.3.2 through I.3.4 provided the statistics required for the comparative analysis performed in Subtask I.3.5. The products of Tasks I.1 through I.3 provided the basis for conclusions and the recommended standards in Task I.4.

Phase II was accomplished in a single effort based on the lessons learned in Phase I and the applicability of Phase I findings to the 1986

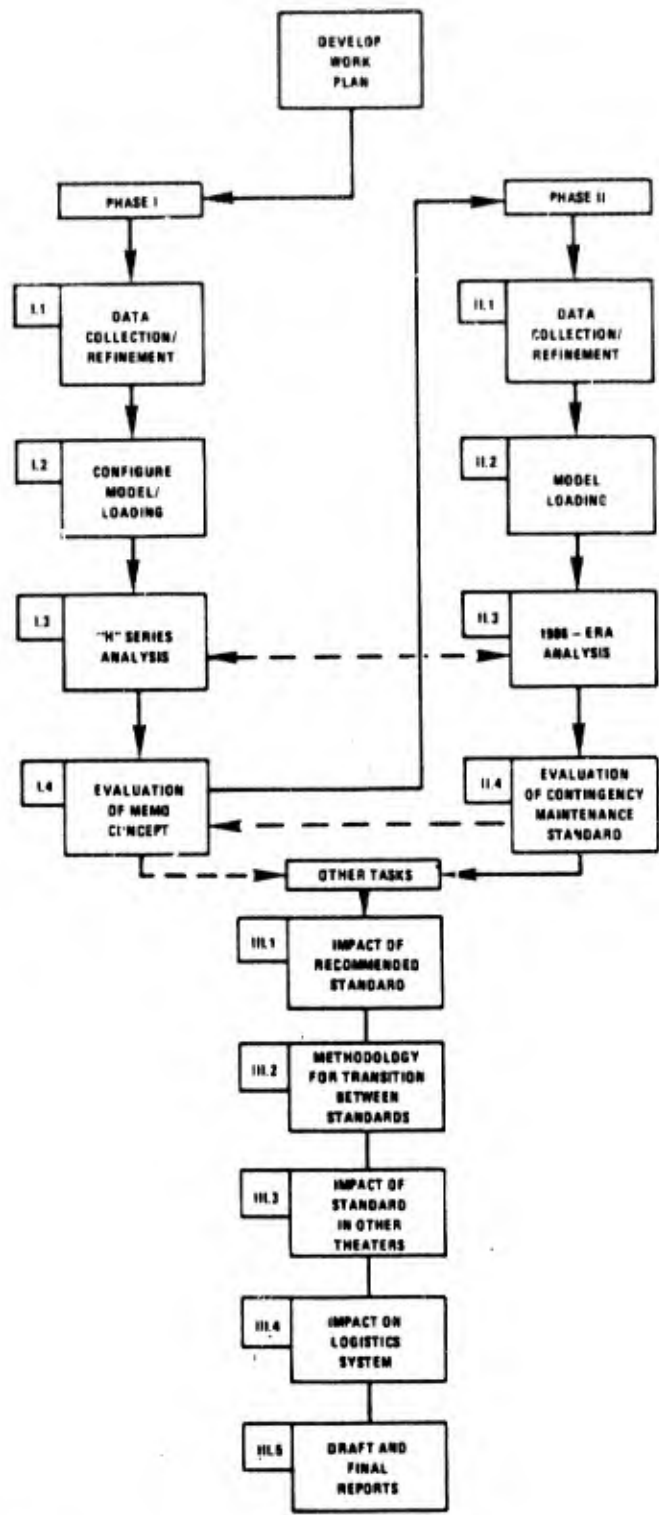

1899/81W

Figure II-1. Methodology Flowchart

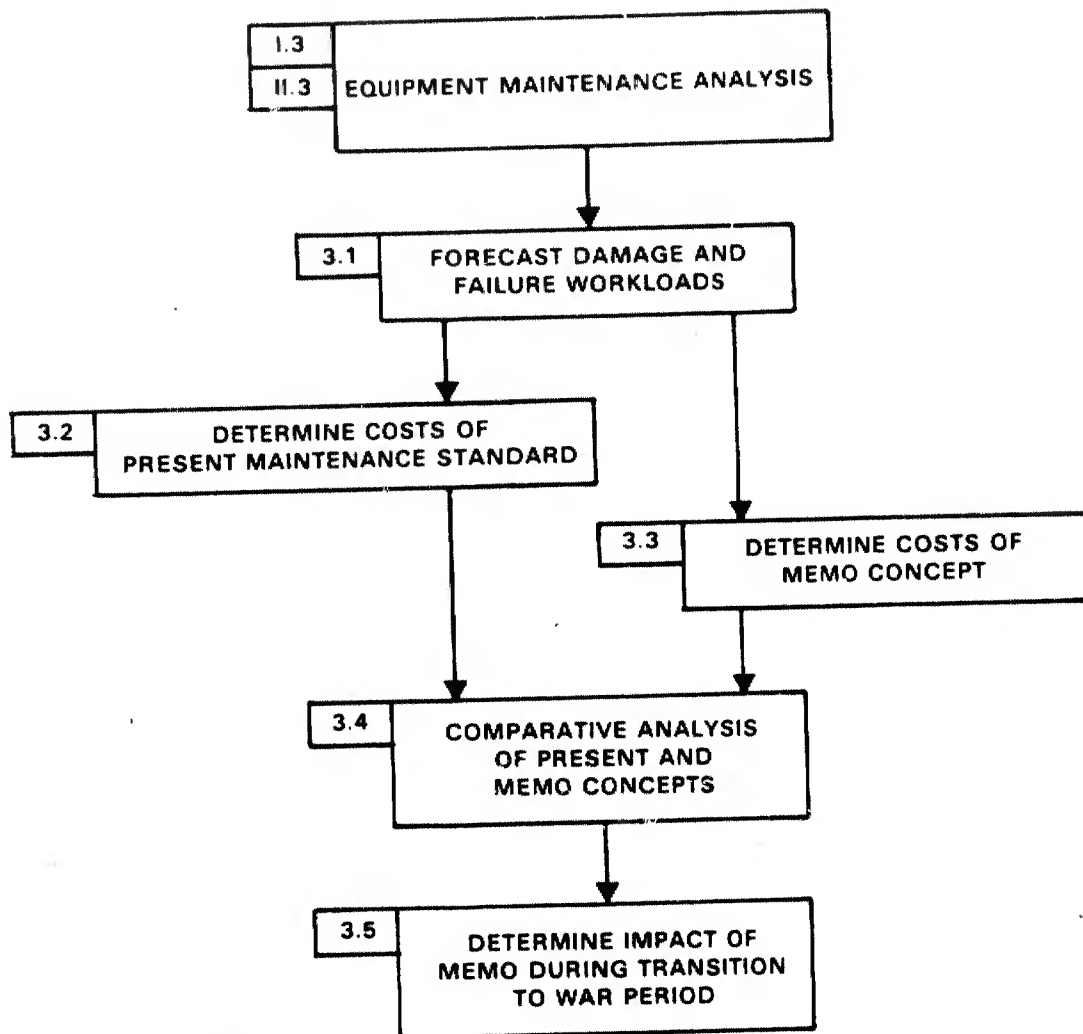

1899/81W

Figure II-2. Equipment Maintenance Analysis Methodology

THE BDM CORPORATION

era equipment. Simulation modeling was not used due to incomplete and unvalidated data at this time. Nevertheless, it was still possible to judge the applicability of the MEMO contingency standard to 1986-era equipment. The data and results of Phase I and Phase II were used to complete Phase III, Other Tasks.

The analysis made extensive use of the Maintenance Capabilities Attack (MACATAK) simulation model. MACATAK is a high resolution maintenance model specifically designed to analyze the inner workings of a maintenance support system and to determine impacts of scenario-generated workloads on the maintenance system and the operational availability of end items over space and time. MACATAK accurately takes into account the dynamics and synergisms that exist within the maintenance system and realistically responds to peacetime, transition and wartime scenario inputs. The model outputs provide quantitative data to include both tabular statistics and graphs which enable individual MOS utilization, component utilization, repair parts availability, maintenance backlogs, and the operational availability of each equipment type to be observed on a day-to-day basis throughout the period of the simulation. The MACATAK simulation model is ideally suited for the type of analysis required for this study. A comprehensive description of the MACATAK model is contained in Appendix A.

a. Method of Performance

The BDM Corporation achieved the objective of this effort by fulfilling the requirements of the specific tasks delineated in the following paragraphs.

1) Task I - "H" Series Equipment

The Phase I effort evaluated the validity of the MEMO concept applied to selected "H" series TOE equipment (M-60A1 Tank and M-113 APC, M-109 Howitzer, and M-813 five-ton truck) and recommended the maintenance standard to be adopted during the transition to war and during contingencies. The analysis encompassed a 120 day transition period and beyond, to six months. Combat intensities, duration of war phases, and losses provided in the European scenario used in OMNIBUS 81 were used in

THE BDM CORPORATION

the analysis. The initial emphasis of the analysis focused on the 120 day transition period to determine the benefits, shortcomings and manhour and dollar costs achieved by the application of the MEMO concept. Emphasis then shifted to the period beyond 120 days to determine subsequent impacts of MEMO deferred maintenance workloads on the maintenance support system and the operational availability of the selected equipment items.

The following subtasks were accomplished as part of this task.

- (1) Subtask I.1 - Data Collection and Refinement,
 - (a) Subtask I.1.1 - Collect "H" Series TOE data on systems that are not currently available,
 - (b) Subtask I.1.2 - Refine equipment maintenance data for the Maintenance Task Demand File (MTDF),
 - (c) Subtask I.1.3 - Determine maintenance workloads from attrition rates and combat damage.
- (2) Subtask I.2 - Configure maintenance model MACATAK and load data.
- (3) Subtask I.3 - Perform "H" series equipment analysis under standard and MEMO concepts,
 - (a) Subtask I.3.1 - Forecast combat losses, damage and technical failures,
 - (b) Subtask I.3.2 - Determine Workload Costs of Current Maintenance Standard,
 - (c) Subtask I.3.3 - Determine Workload Costs of MEMO Concept,
 - (d) Subtask I.3.4 - Perform comparative analysis of the current and MEMO standards,
 - (e) Subtask I.3.5 - Determine impacts of MEMO concept on equipment and maintenance system.
- (4) Subtask I.4 - Evaluation of MEMO concept methodology and recommendation of standard,
 - (a) Subtask I.4.1 - Evaluation of MEMO concept from model results,
 - (b) Subtask I.4.2 - Development of contingency maintenance standard in terms of MEMO.

2) Task II - 1986 Era Equipment

In this task BDM evaluated the validity of applying the contingency maintenance standard to selected 1986 era equipment (M-1, "Abrams" Tank; M-2/3, "Bradley" infantry and cavalry fighting vehicles; M-901, improved tow vehicle, and the XM-987 multiple launch rocket system) during the transition to war period.

Although the use of simulation modeling to accomplish Phase II was contemplated, the study team in concert with the Army Study Advisory Group determined that modeling 1986 era equipment would be neither necessary nor prudent. First of all, the lessons learned during the Phase I effort and the applicability of Phase I findings to the 1986 era equipment indicated that the Phase II effort could be accomplished satisfactorily without the use of simulation modeling. Secondly, the point to which some of the 1986 era equipment had progressed in the new equipment development and test cycles precluded the availability of some data. Other data had not yet been validated. The results of any simulation based upon incomplete data and data that had not been validated would be highly questionable and could cast doubt on the validity of the entire effort. It is felt that the methodology utilized in this study should be applied to the future equipment when valid data becomes available. The following sub-tasks were accomplished as part of this task :

- (1) Subtask II-1. Data Collection and Refinement
 - (a) Subtask II.1.1 - Collect data on 1986-ERA TOE and systems
 - (b) Subtask II.1.2 - Collect equipment maintenance data.
 - (c) Subtask II.1.3 - Determine maintenance workloads from attrition data and combat damage.
- (2) Subtask II-2 - Configure MACATAK Model (since the decision was made not to attempt simulation, the data was prepared for entry into the data base but, the model was not loaded for simulation).
- (3) Subtask II-3 - Analysis of MEMO for 1986-ERA equipment analysis
 - (a) Subtask II.3.1 - Forecast combat losses, damage and technical failures.

- (b) Subtask II.3.2 - Perform comparative analysis of the current and proposed contingency maintenance standard.
- (c) Subtask II.3.3 - Determine impacts of contingency maintenance standard on equipment and maintenance system.
- (4) Subtask II-4 - Evaluation of contingency maintenance standard
 - (a) Subtask II.4.1. - Evaluation of the contingency maintenance standard.
 - (b) Subtask II.4.2 - Recommendations.

In spite of the tentative nature of Phase II data, it was still possible to judge the applicability of the MEMO contingency standard to 1986 era equipment. It is believed that the MEMO standard will be a valid concept for Phase II items provided that good management is a part of its application.

Furthermore, analysis of the data available on Phase II end items revealed significant differences in 1986 era equipment that may change the mission profile of organizational and direct support maintenance and may aggravate known problems in the maintenance system. These areas are addressed in Chapter V.

3) Task III - Other Tasks

a) Subtask III-1 - Determine Contingency Standard Impacts on Current Policies, Procedures, and Doctrine

The quantitative data obtained from MACATAK simulation runs made during Subtask I.3.1 (Workload Forecasts), I.3.2 (Current Standard), I.3.3 (MEMO Workload/Costs), I.3.4 (Comparative Analysis), I.3.5 (MEMO Impacts) combined with the evaluation of MEMO in Task 1.4 and the analytical effort of Phase II enabled the impacts of the contingency maintenance standard on AR 750-1 to be determined and defined. Particular emphasis was placed on maintenance doctrine and procedures.

b) Subtask III-2 - Interface Present Maintenance Methods With the Contingency (Maintenance) Standard

The key to smooth transition to and from the Contingency Maintenance Standard (CMS) is prior planning. This subtask analyzed the problems of when and how to implement such transitions.

c) Subtask III-3 - Determine Contingency Maintenance Standard Impacts on Other Theaters and Operations

The impacts of adopting the Contingency Maintenance Standard (CMS) for operations in Korea, Southwest Asia, and other geographical areas were determined by assessing the problems of operations and maintenance in such environments and the resulting impacts on the implementation of the CMS. Consideration was given to force package and logistic planning considerations such as the size and composition of force packages, logistic support packages, duration of operations as well as accompanying supplies and modes of providing resupply support.

d) Determine Contingency (Maintenance) Standard Impacts on Other Aspects of the Logistics System

The impacts of the Contingency Maintenance Standard on logistics system areas were analyzed. General areas of interest included stockage and resupply of major end items, major components and assemblies; evacuation; turnaround times associated with stockage levels, locations, and actual repair; and special controls or management procedures that may be required. Consideration was given to both the one for one impacts of contingency maintenance standard and diffused impacts that occur due to the inner dynamics, synergisms and relationships that exist within the maintenance system. In each case, the key elements were maintenance actions, the locations at which they are performed, who performs them, and the stockage levels and locations, maintenance organization MOS requirements, and transportation requirements.

A specific area of major interest during the analysis was the impacts associated with devoting available manpower

resources in forward maintenance units to the repair of end items as opposed to the current division of labor between end items and reparable components. The analysis addressed the impacts and trade-offs associated with either deferring the repair of reparable components or evacuating reparable components to centralized repair facilities in rear areas. The impact on supply requirements for reparable components was also analyzed. The focal points of the analysis included MOS requirements in forward units, DX stockage levels and locations, associated transportation impacts, and possible impacts on operational availability.

e) Subtask III-5 - Prepare Draft and Final Reports to Meet Study Requirements

The required study reports were provided in accordance with delivery schedules. Extensive use was made of computer graphics throughout the report to support the findings and recommendations. Such graphics permit both the analyst and those who will use the report to observe the dynamics of the maintenance system variables, and the impacts of conceptual approaches on individual variables over space and time. The graphics, combined with the data bases and tabular data associated with them, and the extensive BDM experience will provide accurate descriptions of the maintenance systems, standards, and advantages and disadvantages associated with the conceptual approaches.

b. Report Structure

The remaining chapters and appendices of this report address the subjects indicated:

- (1) Chapter III - "H" Series Equipment Analysis (Task I);
- (2) Chapter IV - Contingency Maintenance Standard;
- (3) Chapter V - 1986 Era Equipment Analysis (Task II);
- (4) Chapter VI - Other Tasks (Task III);
- (5) Chapter VII - Observations;
- (6) Chapter VIII - Conclusions and Recommendations; and,
- (7) Appendix A - The MACATAK Model.
- (8) Appendix B - Contingency Maintenance Standard Addition to AR 750-1.

CHAPTER III
"H" SERIES EQUIPMENT ANALYSIS

A. INTRODUCTION

1. Phase I Tasks

The Phase I study effort evaluated the MEMO concept and determined the impacts of deferring maintenance workloads as the MEMO concept was applied to selected "H" series equipment (M-60, M-109, M-113, M-813). Phase I was accomplished by four subtasks. Subtask I.1 consisted of data collection and refinement. It included obtaining "H" series TOEs for an armored division; obtaining and completing technical maintenance data for the four selected items of equipment; and determining equipment attrition rates and combat damage for each type equipment during the 120 day transition period. Subtask I.2 consisted of configuring the MACATAK model to represent the maintenance system of the armored division and to measure workloads at the general support maintenance level. This subtask also included loading the MACATAK model with the data previously collected and beginning test simulation runs. Subtask I.3 consisted of using simulation runs to analyze the impacts of the MEMO concept and of deferred maintenance workloads. Each simulation run encompassed a 120 day transition period plus an additional 60 day recovery period. During the 120 day transition period, workloads which included normal technical failures, combat losses and combat damage were quantified for the current maintenance standard and MEMO. The system response to demands generated by these workloads was measured in terms of operational availability of each end item over space and time. The 60 day recovery period was used to assess the impacts of deferred maintenance workloads attributable to essential deferred and nonessential maintenance actions. Subtask I.4 involved development of a contingency maintenance standard based upon the results of the MEMO analyses.

THE BDM CORPORATION

2. Study Objectives

The ultimate objective of the MEMO study was to produce data, findings and recommendations that can be used to develop recommended material stationing and force structure for maintenance units while transitioning to a wartime posture. The specific objectives of the Phase I effort were to determine:

- (1) the validity of the MEMO concept and its application,
- (2) the contingency maintenance standard to be adopted during transition to war, and
- (3) to gain insights into the risks and trade-offs associated with adopting a deferred maintenance approach during the transition period.

3. MEMO Expectations and Realizations

a. Expectations

The basic premise of the MEMO concept is that equipment operational availability can be improved or at least maintained by an understrength work force during the transition period (120 days) by accomplishing only mission essential maintenance actions (e.g., deferring other maintenance actions). This premise is based upon the following key assumptions.

- (1) Deferrable and nonessential maintenance actions identified in the 42 series FMs constitute a substantial workload.
- (2) Deferring these maintenance actions during the transition period will result in substantial savings in manpower.
- (3) The manpower savings will enable a work force at full strength to increase operational availability or will enable a work force at reduced strength to at least maintain desired levels of operational availability.

b. Realizations

Analyses of the simulation results and the manner in which the MEMO concept was applied indicated the following.

- (1) The application of MEMO produced an increase in operational availability for some end items but not for others.

THE BDM CORPORATION

- (2) Manpower savings realized during the MEMO application period occurred for some MOSs but not for others.
 - (3) The application of MEMO caused a reduction in demands for repair parts and DX items at some levels of maintenance but an increase in demands at others.
 - (4) The application of MEMO without proper management can cause maintenance workloads for some end items to increase at forward levels of maintenance rather than decrease.
4. Configuring and Loading the MACATAK Simulation Model

a. MACATAK Configuration

The MACATAK simulation model was configured as shown in Figure III-1 to reflect the maintenance system of an armored division. The organizational nodes (ORG 01, 02, 03, and 04) represent organizational maintenance to include recovery and the density of each end item supported by the node. ORG 01, 02, and 03 represent the three brigades of the division while ORG 04 represents the divisional units located in the division rear area. The three forward direct support nodes (FDS 01, 02, and 03) represent the direct support maintenance companies positioned in each brigade area. The rear direct support node (RDS 01) represents those companies of the division maintenance battalion located in the DISCOM area. The general support maintenance node (GSMNT) represents the GS maintenance capability of the COSCOM. (A more detailed description of the MACATAK model is provided in Appendix A.)

b. Unit TOE Data

"H" Series TOEs for the armored division were obtained to determine the densities of each selected end item (M-60, M-109, M-113, M-813) to be supported by each organizational node, the quantities by MOS of maintenance personnel authorized at each DS unit and the lift equipment authorized each DS unit. Lift equipment in this case was defined as wreckers authorized for use in the maintenance area. Recovery vehicles were not considered as being available for use as lift equipment due to their combat recovery mission.

MEMO STUDY — PHASE I — MACATAK CONFIGURATION

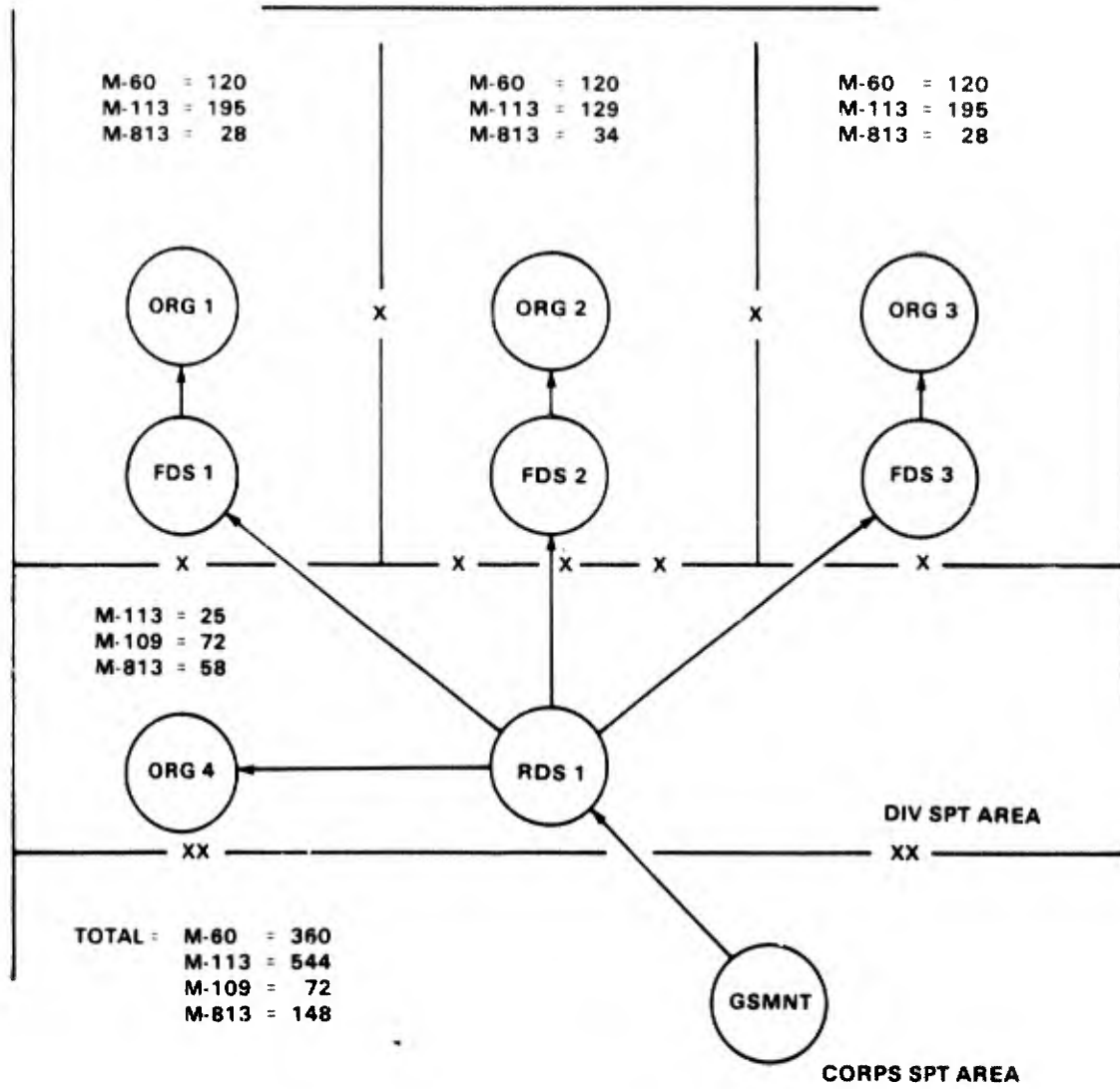

Figure III-1. MACATAK Model Configuration

THE BDM CORPORATION

c. Supply Policy and Resupply

AR 710-2 was used as the basis for determining supply policy inputs to the model. These included determination of ASL and NSL items, DX items, calculation of initial DX inventories, and determination of the availability of ASL items at each divisional maintenance node. Resupply delays or order ship times (OST) were based upon information provided by the US Army Logistics Center and from quarterly air lines of communication (ALOC) reports.

d. Detailed Maintenance Data

The MACATAK model employs a preprocessor to draw the technical maintenance data it requires from the Maintenance Task Demand File (MTDF). The type data required is shown in Table III-1. The MTDF is maintained by the Logistics Center at Data Processing Field Office (DPFO), Ft. Leavenworth. Extensive assistance was provided to the BDM study team by representatives from the Ordnance School, in updating the maintenance data for the M-109 and M-113 in order to complete the data base and to properly reflect deferred and nonessential maintenance actions identified in the 42 series FMs. The technical maintenance data was used to generate the normal maintenance workload based upon the frequency of occurrence specified for each maintenance action. It was also used to reflect the combat damage workload by identifying those maintenance actions required by each shotline specified during various model runs. (The content of the MTDF and the level of detail required by the MACATAK model are discussed in Appendix A.)

e. Scenario

The US Army, Concept Analysis Agency's (CAA) OMNIBUS Capability Study FY81 (OMNIBUS 81) and Wartime Requirements for Ammunition and Material, FY82-86 Study (AMMO P-86/WARF 86) were used to determine combat intensities, duration of war phases and loss rates that could be expected for each of the four equipment items during the 120 day transition period. OMNIBUS 81 evaluated the end FY81 capability of the Army to provide, deploy, and sustain a force in support of a Southwest Asia (SWA) contingency followed by a NATO conflict. The NATO conflict included a

THE BDM CORPORATION

TABLE III-1. MTF DATA USED BY MACATAK

NOTE: WHEN ACCESSING THE MTF THE END ITEM NOMENCLATURE AND END ITEM TYPE ARE SPECIFIED BY THE PRE-PROCESSOR.

1. FUNCTIONAL GROUP CODE
2. MAC LINE NUMBER
3. MAINTENANCE TASK NAME
4. REPARABLE COMPONENT
5. COMPONENT WASHOUT RATE
6. APPLICABLE SCENARIO
7. LEVEL OF REPAIR RECOMMENDED
8. MISSION ESSENTIAL, HOT ENVIRONMENT
9. MISSION ESSENTIAL, COLD ENVIRONMENT
10. END ITEM IMMOBILE
11. LIFT EQUIPMENT REQUIRED
12. REPARABLE BY CONTACT TEAM
13. REPARABLE WHILE ON THE END ITEM
14. MINIMUM MOS FACTOR
15. FREQUENCY OF TASK OCCURRENCE
 - a. PROBABLE VALUE (NORM)
 - b. MEASUREMENT INDEX
16. TASK TIME OR TIME TO REPAIR (PROBABLE VALUE)
17. NORMAL MANPOWER REQUIREMENTS
 - a. MOS
 - b. NUMBER
18. REPAIR PARTS
 - a. IF REPAIR PARTS ARE REQUIRED
 - b. IF A REPLACEMENT COMPONENT (DX ITEM) IS REQUIRED

major Warsaw Pact Organization (WPO) thrust against the Northern Army Group (NORTHAG) and powerful, yet secondary, attacks on the Central Army Group (CENTAG). The US division evaluated in Phase I was a forward deployed division stationed in Germany.

f. Attrition Rates and Maintenance Workloads

To permit the comparative analysis of the MEMO concept and the current maintenance standard, attrition rates had to be translated into maintenance workloads. In the non-combat environment, the maintenance problem normally consists of repairing technical failures. These failures usually occur at rates corresponding to the intensity of equipment use and at a ratio of approximately one item to one failure. The maintenance workload attributable to technical failures over time is a function of equipment densities (obtained from "H" Series TOEs), usage intensities (obtained from the OMNIBUS 81 Scenario and AMMO P-86/WARF 86), and frequencies of occurrence for each maintenance action (obtained from the MTDf and other sources).

During wartime the maintenance problem consists of repairing both technical failures and combat damage. Unlike technical failures, combat damage normally results in several damaged or destroyed parts on each combat damaged equipment item. Furthermore, the need to repair some items is eliminated as some equipment is damaged beyond repair and some is not recoverable. The maintenance actions associated with each combat damaged item were determined using a single shotline probability methodology.

The attrition input data required by the MACATAK model was developed by using combat loss and combat damage rates provided by CAA, shotlines developed during the Theater Nuclear Force Survivability (TNF/S) program, shotline data provided by the US Army Material Systems Analysis Activity (AMSAA), and recoverability rates provided by the Ordnance Center. Table III-2 provides an overview of the type data required and the sources of the data.

TABLE III-2. ATTRITION DATA AND SOURCES

- FROM OMNIBUS 81
 - COMBAT INTENSITY
 - COMBAT DAMAGE - M-60 AND M-113
 - CATASTROPHIC LOSSES AND
 - NON-CATASTROPHIC LOSSES

- FROM AMMO P-86/WARF P-86
 - M-109 AND M-813 CATASTROPHIC LOSS DATA

- FROM ARMY MATERIAL SYSTEMS ANALYSIS ACTIVITY
 - M-109 AND M-813 NON-CATASTROPHIC LOSS DATA
 - SHOTLINES

B. OVERVIEW OF SIMULATION RUNS

1. Introduction

Three basic simulation runs were made during the Phase I analysis. These simulation runs were designed to determine the validity of the MEMO concept, determine the risks and trade-offs associated with deferring maintenance actions and to provide the basis to develop a contingency maintenance standard. The three basic simulation runs were structured so that the impacts of the MEMO concept and deferred maintenance approaches could be observed and compared throughout the analysis process. The first simulation run consisted of a non-MEMO baseline; the second a MEMO run in which both nonessential and deferrable maintenance actions were accumulated and then worked off; and the third a run in which only deferrable maintenance actions were accumulated and then worked off. These simulation runs are portrayed in Figure III-2.

2. Non-MEMO Baseline Run (Run 1)

The non-MEMO baseline run was designed to meet the requirements of Task I.3.2 and to provide the basis for comparison of the MEMO and deferred maintenance action simulation runs. It was divided into two parts. The first portion of the simulation run (D to D+120) included accomplishing all maintenance actions that occur due to usage failure plus those additional actions attributable to combat damage. The second portion of the simulation run (D+121 to D+180) consisted of a recovery period during which there was no combat damage but during which all maintenance actions that occurred due to usage failures were repaired. At no time during the baseline run were maintenance actions deferred.

This approach enabled the analyst to view the performance of the maintenance system operating in combat under the current maintenance support concept as well as the ability of the maintenance system to recover from the combat damage workload. The tabular statistics and graphs generated by the baseline simulation run provided the basis for comparison

PHASE I SIMULATION RUNS

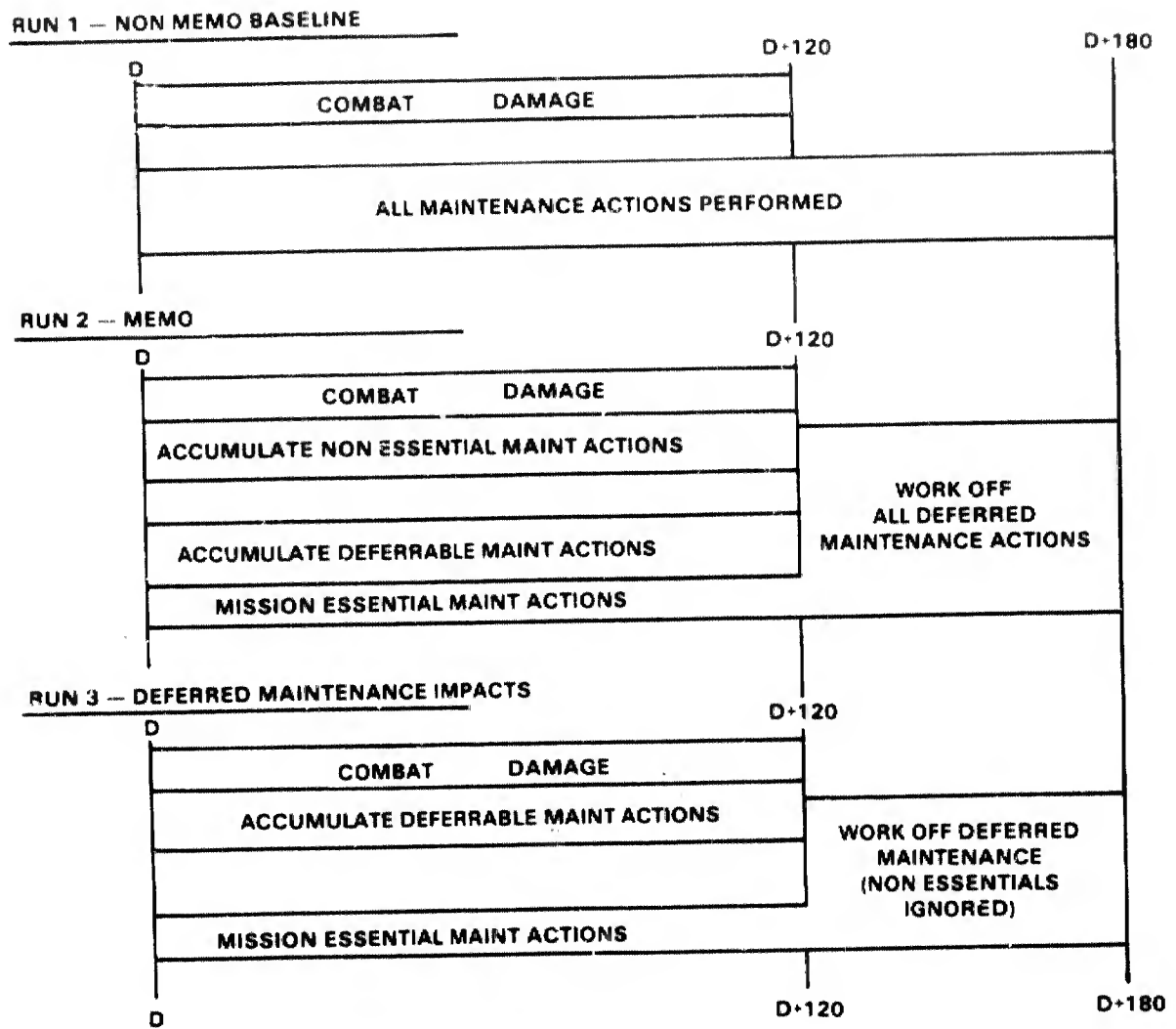

Figure III-2. Overview of Phase I Simulation Runs

of the MEMO and deferred maintenance action simulation runs (Runs 2 and 3). In this way, the impacts of the MEMO concept and deferred maintenance action workloads could be measured.

3. MEMO Simulation Run (Run 2)

The MEMO simulation run was designed to meet the requirements of Task I.3.3, to measure the impacts of the MEMO concept during combat and to measure the impact of deferred maintenance workloads that were accumulated during the MEMO period. The simulation run was divided into two portions each of which is the same length in time as the baseline run to facilitate direct comparison. During the first portion of the MEMO simulation run (D to D+120), the maintenance system was operated in combat under the MEMO concept. Nonessential and other deferrable maintenance actions were accumulated and worked off during the second portion of the run (D+121 to D+180). As in the baseline run, combat damage did not occur during the second portion of the simulation run. During the second portion of the MEMO simulation run MEMO was "turned off" and all maintenance actions were performed, including all accumulated nonessential and deferred maintenance actions.

This approach provided for the full utilization of available resources during the MEMO period, enabled analysts to observe changes in operational availability attributable to MEMO and to measure the impacts of the deferred maintenance (both nonessential and other deferred maintenance actions) workload on the maintenance system. The tabular statistics and graphs produced by the MEMO simulation run were directly comparable to those produced by the baseline run.

4. Deferred Maintenance Action Impacts Simulation Run (Run 3)

Since nonessential maintenance actions can be either deferred indefinitely or eliminated, and some essential maintenance actions can be deferred for given periods of time before they must be accomplished, this simulation run was designed to measure the impact of working off maintenance actions that are identified as deferrable in the 42 series field manuals and ignoring those identified as nonessential. The impacts

THE BDM CORPORATION

of deferrable maintenance actions are observed by comparing the tabular statistics and graphs directly with the other runs from D + 121 to D + 180. The impacts of nonessential maintenance actions can be measured by making comparisons between Run 3 simulation run and the MEMO simulation run.

The first portion of this simulation run and the first portion of the MEMO simulation run were the same. Both included combat damage and performance of essential maintenance actions. Only deferrables were accumulated during the D to D + 120 period of the simulation run. No consideration was given to nonessential maintenance actions. During the second portion of the run all accumulated deferrable actions were worked off, plus any normal reliability failures that occurred during the second portion of the run. Nonessential maintenance actions were not accumulated during the first portion of the run or worked off during D+121 to D+180 day period.

C. ANALYSIS OF SIMULATION RESULTS

1. Modification of Input Data

The first run, referred to as the non-MEMO Baseline Simulation Run (Run 1) was constructed to reflect as accurately as possible the performance of the "H" series armored division maintenance system operating under the current maintenance standard over space and time. It established the baseline for comparisons with the other two simulation runs required to evaluate the MEMO concept and determine specific impacts of deferred maintenance workloads. Before a satisfactory simulation run of 180 days could be obtained several iterative runs were necessary.

The initial run was attempted using TOE manpower and equipment authorization for the DS forward and DS rear maintenance units and supply policy as specified in AR 710-2 for ASL, NSL, and DX items. Supply policy considerations included ASL and NSL order ship times (OST) approximated to those currently being experienced by units in USAREUR. In the next series of simulation runs substantial adjustments had to be made in the supply

policy area to insure that the maintenance system had repair parts and DX items sufficiently available to reasonably accomplish the maintenance workload. This was followed by another series of simulation runs in which lift equipment authorizations were increased on a selective basis until sufficiently available to reasonably accomplish the maintenance workload. Increased authorizations of selected MOSs were also required. The adjustments to supply policy, OSTs, equipment and manpower authorizations were all made based upon analyses of tabular data and graphs produced by each iterative simulation run. A summary of these adjustments is provided in Table III-3.

2. Non-MEMO Baseline Simulation Run (Run 1)

a. Operational Availability

The MACATAK simulation model produces operational availability graphs at each organizational maintenance node (ORG 01-04) for each end item being examined. These graphs are analyzed in conjunction with supporting tabular statistics and graphs which portray and quantify the maintenance system response to workloads over space and time at each echelon of maintenance. Table III-4 was prepared from the tabular statistics to provide a summary of the average operational availability rates for each end item at each organizational maintenance node during the D to D + 120 period.

Based upon an analysis of the tabular statistics and operational availability graphs, the operational availability graphs at ORG 01 for the tank, truck, and APC and at ORG 04 for the truck and howitzer were determined to be representative of the equipment operational availability graphs for ORG 01-04. These graphs are shown in Figures III-3 through III-7. They permit the performance of the maintenance system to be observed over time in terms of the operational availability attained for each end item. These graphs and the supporting statistics establish the baseline against which Runs 2 and 3 will be compared.

THE BDM CORPORATION

TABLE III-3. SUMMARY OF ADJUSTMENTS TO OST'S, SUPPLY POLICY, EQUIPMENT, AND MANPOWER AUTHORIZATIONS

ORDER/SHIP/TIMES

<u>PARTS TYPE</u>	<u>ACTUAL RESUPPLY TIMES</u>	<u>TIMES USED IN THE SIMULATION</u>	
NSL	CONUS TO USER	CONUS TO ORG	4-8 DAYS
	40 - 60 + DAYS	CONUS TO FDS	4-5 DAYS
		CONUS TO RDS	3-5 DAYS
ASL	CONUS TO USER	MAX DELAY CONUS TO USER	
	20 - 35 DAYS	4 - 8 DAYS	

SUPPLY POLICY

DX INVENTORIES INCREASED FOR SELECTED REPARABLES ON THE M-813 AND M-113A1

LIFT EQUIPMENT AT RDS

<u>TOE AUTH</u>	<u>USED FOR MODELING</u>
5	10

SELECTED MANPOWER AUTHORIZATIONS

<u>MOS</u>	<u>DESC</u>	<u>NODE</u>	<u>*TOE AUTH (FA SHIFT)</u>	<u>*USED FOR MODELING (EA SHIFT)</u>	<u>AVG BUSY/MAX</u>
41C	FC INST REPAIRER	RDS	4	8	2.3/8
45L	FA REPAIRER	RDS	2	8	6.8/8
63B	LT WH VEH REPAIRER	RDS	3	15	12/15
63G	FUEL & ELEC SYS. REP.	FDS 01-03	1	2	.8/2
63W	WH VEH REPAIRER	RDS	8	16	8/16

*2 SHIFTS OF 12 HRS. 1/2 TOE AUTH USED ON EACH
III-14

THE BDM CORPORATION

TABLE III-4 SUMMARY OF AVERAGE OPERATIONAL AVAILABILITY
AT D + 120 (#OPNL/#AUTH)

<u>END ITEM</u>	<u>NODE</u>			
	<u>ORG 01</u>	<u>ORG 02</u>	<u>ORG 03</u>	<u>ORG04</u>
M-60A1	57.5/120	58.6/120	56.6/120	N/A
M-813	14.7/28	21./34	16.2/28	50.0/58
M-109	N/A	N/A	N/A	29.5/72
M-113A1	113.9/195	66.1/129	114.3/195	16.1/25

ANALYST: JIM BDM COMP
 DATE: 1/7/1982
 RUN NAME: BASELINE RUN 1

** HARLOGS MODEL MACATAN **
 TRANSACTION FILE ANALYZER

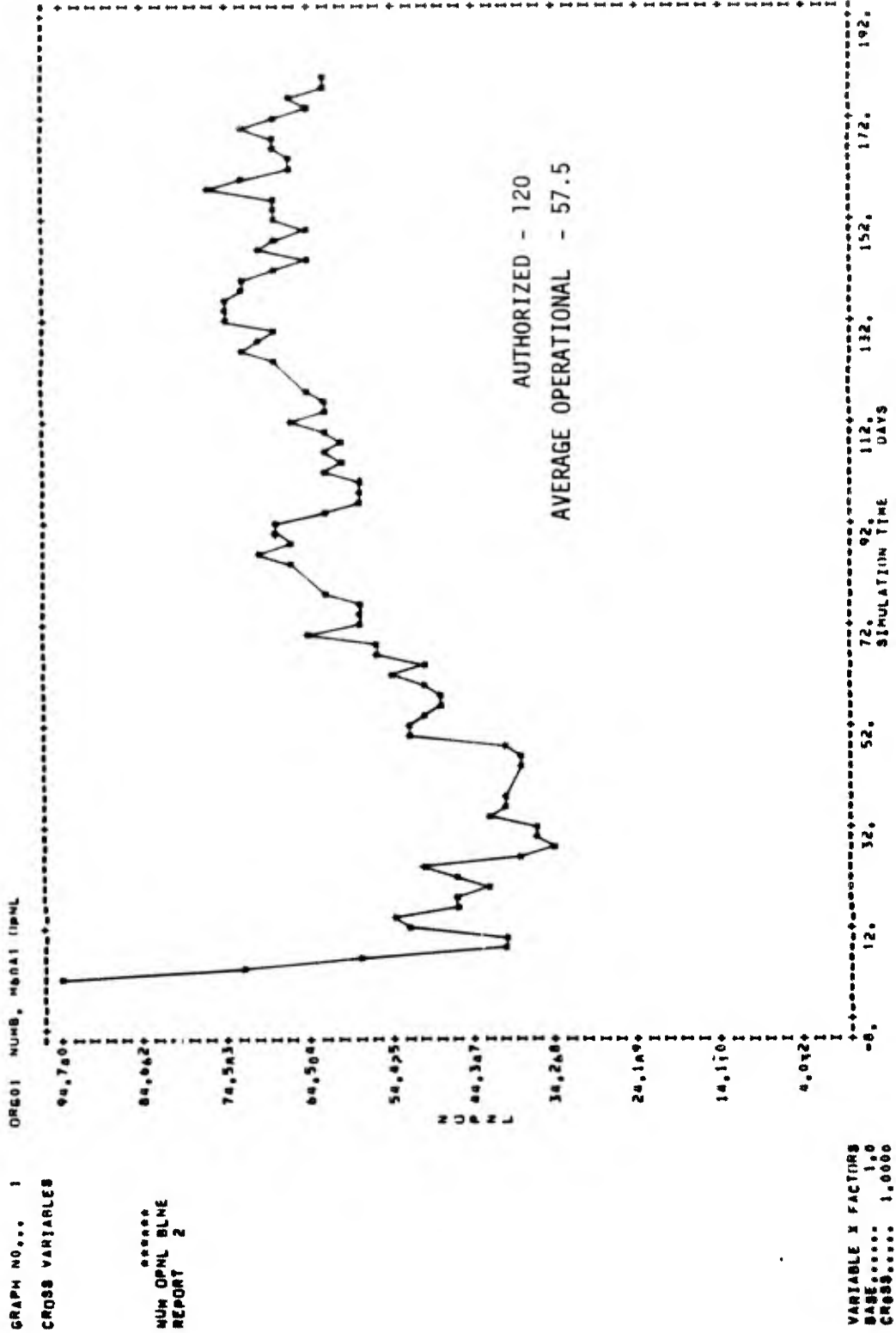

Figure III-3. M60A1 Operational Availability at ORG 01, Baseline Run

ANALYST: THE BDM CORP
 DATE: 1/7/1982
 RUN NAME: BASELINE RUN 1

*** WARELOGS MODEL MACATAK ***
 TRANSACTION FILE ANALYZER

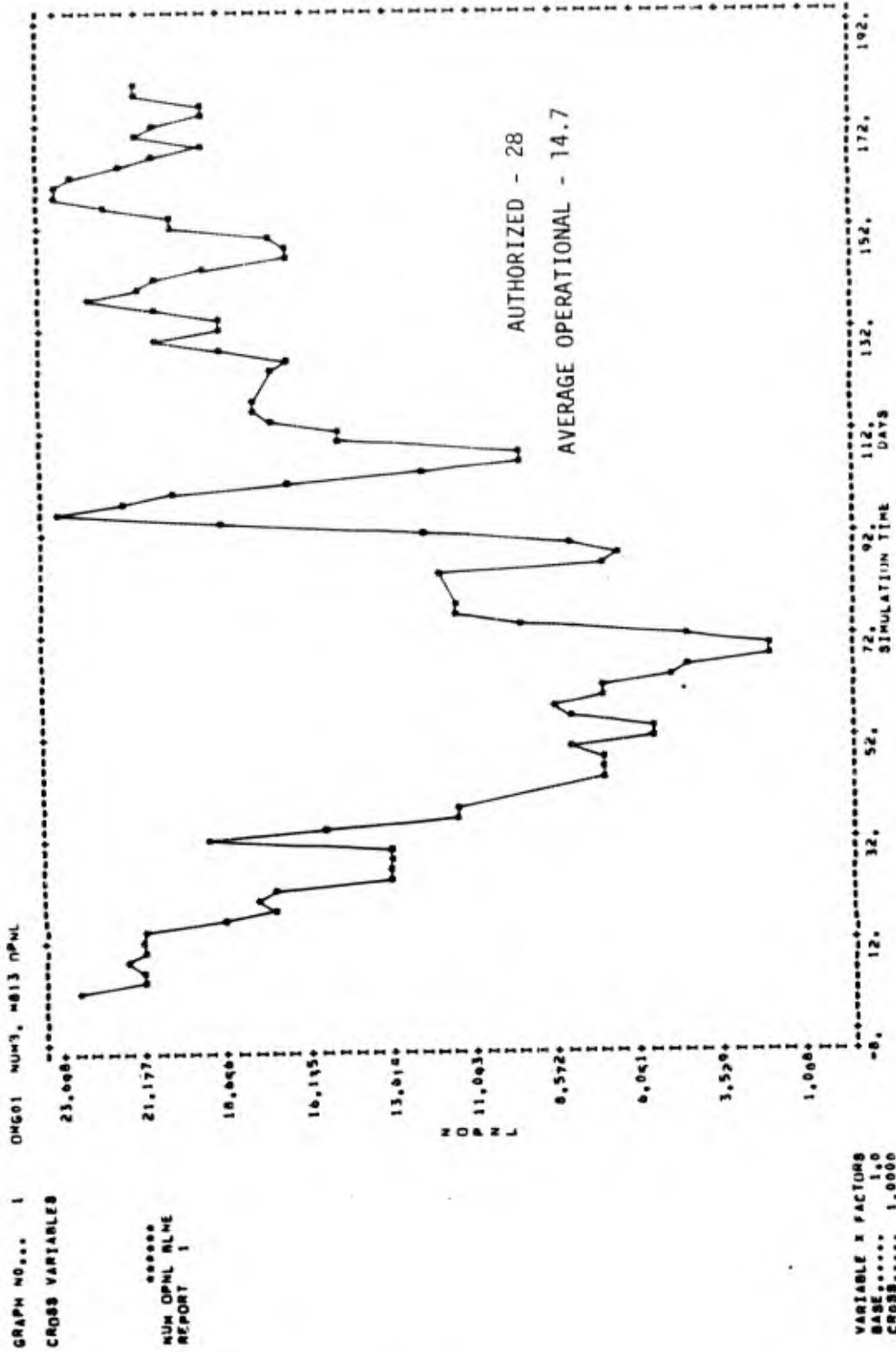

Figure III-4. M813 Operational Availability at ORG 01, Baseline Run

ANALYST, THE BDM CORP
 DATE, 1/ 7/ 1982
 RUN NAME, BASELINE RUN 1

** MA=LOGS MODEL MACATAK **
 TRANSACTION FILE ANALYZER

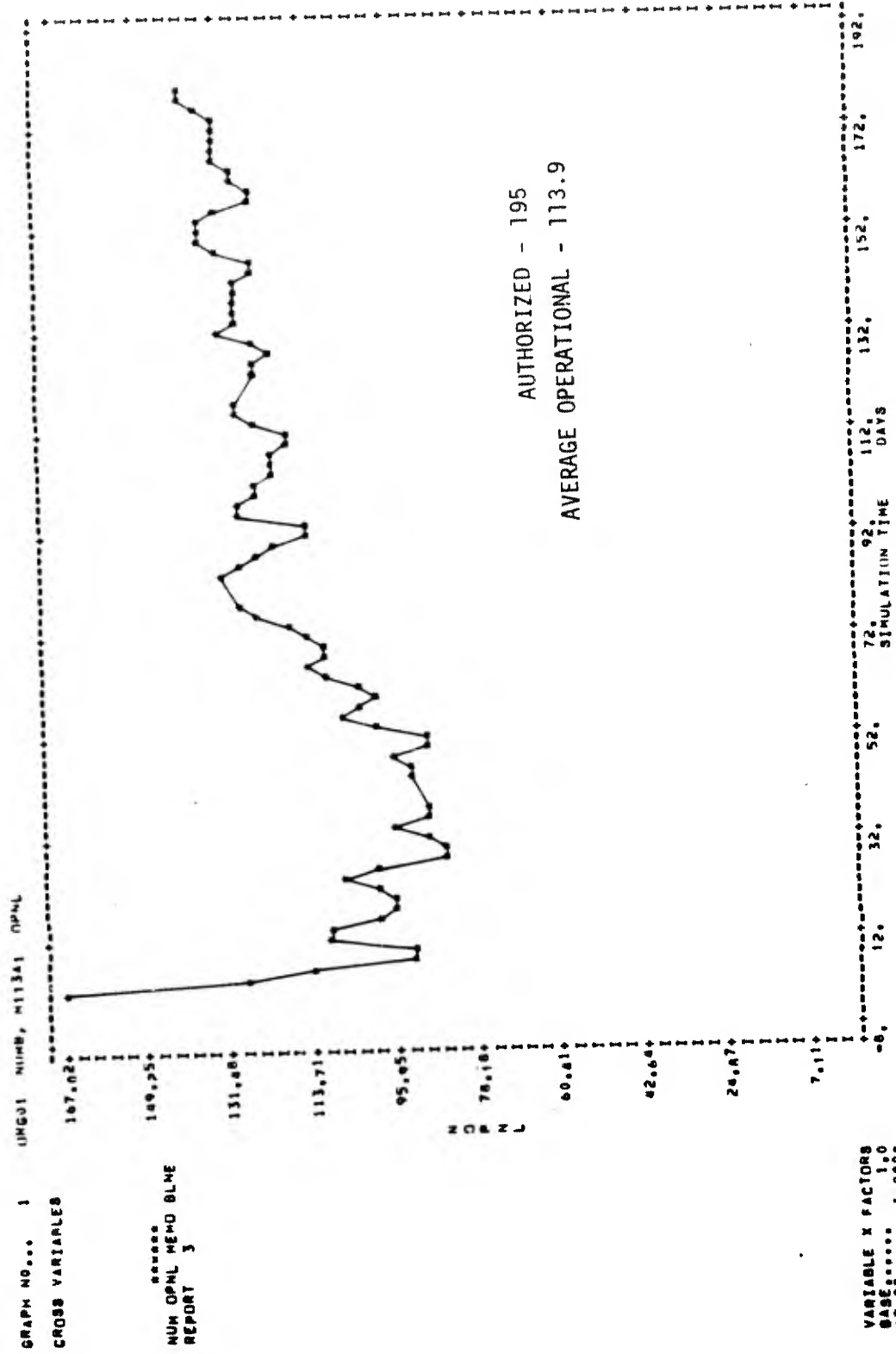

Figure III-5. M113A1 Operational Availability at ORG 01, Baseline Run

ANALYST, THE BDM CORP
 DATE, 1/ 7/ 1982
 RUN NAME, BASELINE RUN 1

** MANUGS MODEL MACATAK **
 TRANSACTION FILE ANALYZER

GRAPH NO... 4
 ORG04 NUMB, M813 OPML

CROSS VARIABLES

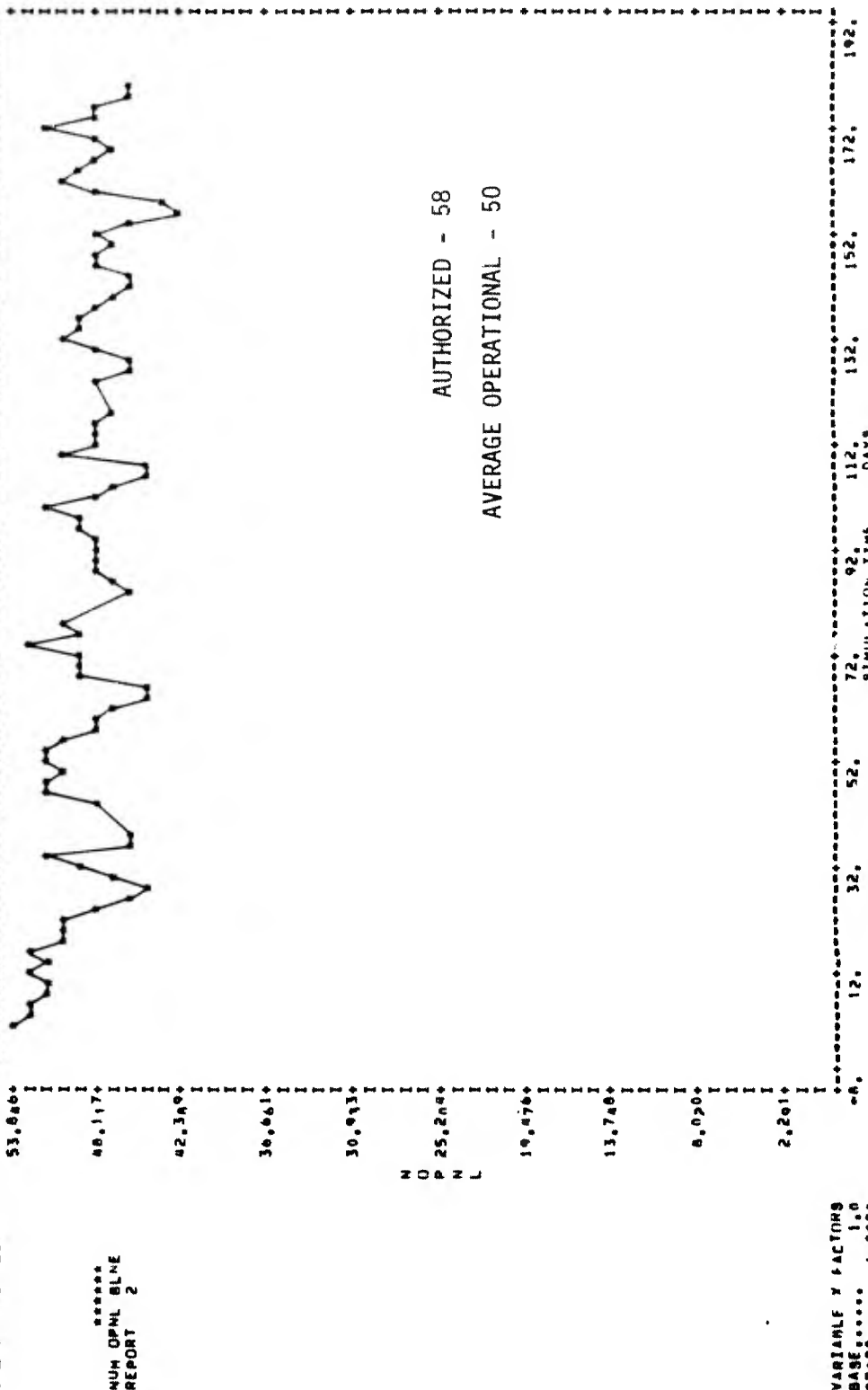

Figure III-6. M813 Operational Availability at ORG 04, Baseline Run

ANALYST, THE BDM CORP
 DATE, 1/ 7/ 1962
 RUN NAME, BASELINE RUN 1

** MATHUGS MODEL MACATK **
 TRANSACTION FILE ANALYZER

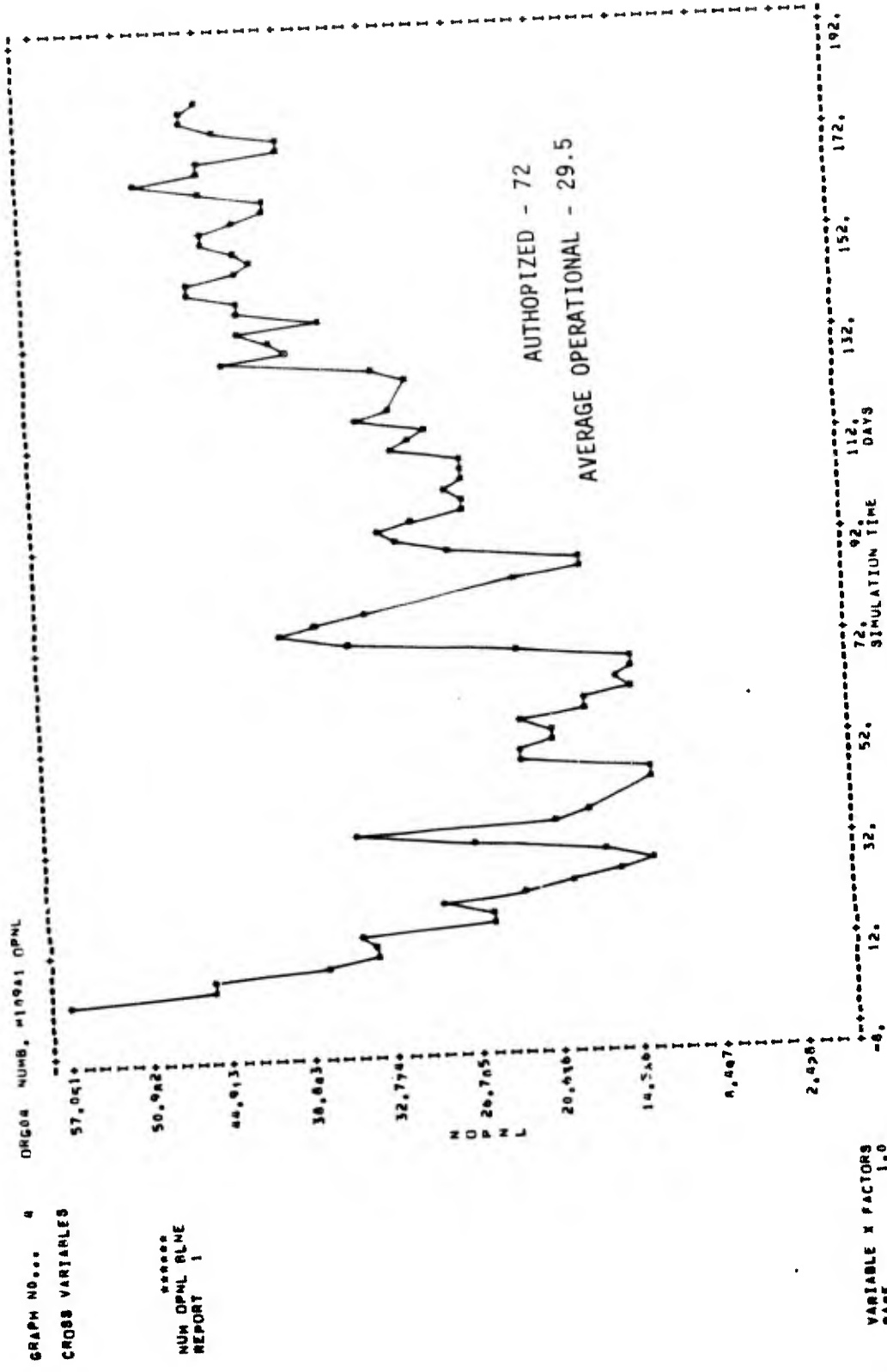

Figure III-7. M109A1 Operational Availability at ORG 04, Baseline Run

b. Resource Expenditures

The detailed statistics concerning the workloads and resource expenditures in the Baseline Run (Run 1) are discussed in Paragraph D below (Analysis of Simulation Results).

3. MEMO Run (Run 2) and Deferred Maintenance Impacts Run (Run 3)

a. Introduction

The discussion of Run 2 and 3 results is divided into two parts. The first portion of the discussion deals with the specific impacts of MEMO, observed during the first 120 days of Run 2. The second portion of the discussion deals with the impact of the maintenance backlog, created by the application of MEMO for 120 days, as it is worked off during D + 121 to D + 180. In this portion of the discussion the specific impacts of deferred maintenance actions can be observed.

b. Impacts of MEMO (D to D + 120)

1) Operational Availability (D to D + 120)

Initial analyses of the simulation runs indicated that each of the end items examined reacted differently to the application of the MEMO concept. For this reason each of the end items are discussed separately in subsequent paragraphs. While some of the deviations can be attributed to equipment design, type of equipment and mission profiles, the manner in which the MEMO concept is reflected in the 42 series FMs has a significant bearing on the results. The content of the 42 series manuals is discussed separately in Chapter VII.

a) M-113A1 Armored Personnel Carrier

Most of the MEMO expectations were realized when the MEMO concept was applied to the APC. Increases in the operational availability of the APC can be observed during the D to D + 120 period in Figure III-8 which portrays the APC during the baseline and MEMO runs. On average, there were 14 more APCs operational in the MEMO run.

The increases in operational availability of the APC during the MEMO application period are due to the size and distribution of the deferred maintenance workload as it occurred over space and time.

ANALYST, THE BDM CORP
 DATE, 1/ 7/ 1982
 RUN NAME, BASELINE RUN 1 & 2

TRANSACTION FILE ANALYZER

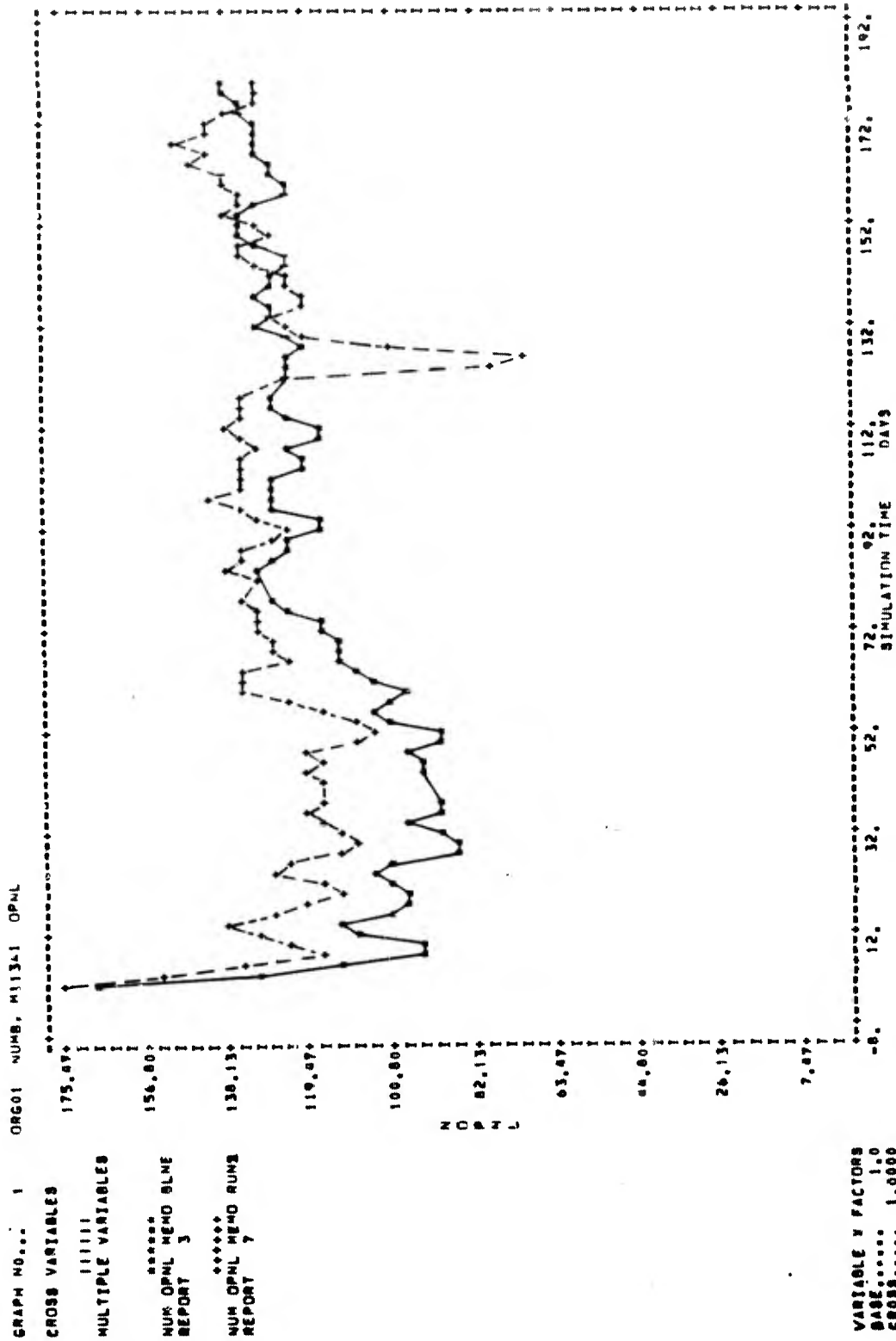

Figure III-8. M113A1 Operational Availability at ORG 01, Baseline vs MEMO

THE BDM CORPORATION

The size of the deferred maintenance workload as it occurred is shown in Table III-5 in terms of maintenance man-hours.

TABLE III-5. DEFERRED WORKLOAD FOR THE APC
(MAN-HOURS)

TYPE MAINT <u>ACTION</u>	<u>MAINTENANCE LEVEL</u>				
	ORG (01-04)	FDS (01-03)	RDS	GS	DEPOT
DEFERRABLE	72	4491	1093	4468	2941
NONESSENTIAL	<u>0.1</u>	<u>11.35</u>	<u>1</u>	<u>1</u>	<u>5</u>
TOTAL DEFERRED	72.1	4502.35	1094	4469	2946

The most significant reduction in workload occurred at the forward direct support level which is the most fragile link in the maintenance system, particularly during combat. Reductions in workloads at the general support and depot levels were also sizable. The maintenance actions at the general support level Table III-6 shows the number of jobs actually received at each maintenance level.

TABLE III-6. NUMBER OF JOBS RECEIVED (APC)

SIMULATION <u>RUN</u>	<u>MAINTENANCE LEVEL</u>			
	ORG 01	FDS 01	RDS	GS
BASELINE (1)	4668	900	554	317
MEMO (2)	<u>3789</u>	<u>493</u>	<u>564</u>	<u>191</u>
DECREASE/INCREASE	-877	-407	+10	-126

The statistics again indicate that the most significant reductions in workload occurred at the organizational and

THE BDM CORPORATION

forward direct support level which is the specific intent of the MEMO concept. Examination of maintenance turnaround times also indicated an improvement in performance under MEMO (Table III-7).

TABLE III-7. MAINTENANCE TURNAROUND TIME (APC)
(IN DAYS)

<u>TYPE FAILURE</u>	<u>BASELINE</u>	<u>MEMO</u>	<u>DECREASE/ INCREASE</u>
RELIABILITY FAILURE	1.06	1.04	-0.02
COMBAT DAMAGE	7.30	5.70	-0.60

The most significant improvement was the 1.6 day decrease in the turnaround time for combat damaged items during the MEMO run.

Queues for repair parts and DX items are shown in Table III-8. In most cases queues for parts were reduced in the MEMO run. This was attributable to the reduction in maintenance actions as a result of MEMO. Increases in queues are attributable to a forward migration of combat damage workloads during MEMO.

TABLE III-8. QUEUES FOR PARTS AND DX ITEMS (APC)
(NUMBER OF JOBS)

<u>TYPE PARTS</u>	<u>ORG 01</u>		<u>FDS 01</u>		<u>RDS</u>	
	<u>BL</u>	<u>MEMO</u>	<u>BL</u>	<u>MEMO</u>	<u>BL</u>	<u>MEMO</u>
DX	0	0.44	0.06	0.06	0.30	0.12
ASL	17	15	20	11	1.8	1.9
NSL	22	12	2	0.5	0.4	0.1

The forward migration of workloads occurs in the simulation runs when the maintenance action in a shotline which caused

repairs to be accomplished at one echelon in the baseline, is deferred during MEMO. As a result of being deferred the remaining workload moved forward during the MEMO run to the next lowest level. This occurred since for the conduct of the simulation runs it was agreed by the Army Study Advisory Group that combat damaged and items were normally evacuated to the highest echelon required to accomplish the repairs. That echelon would then accomplish all repair actions. As a result, during the simulation runs, combat damaged equipment was repaired at the highest echelon indicated in the shotline. For example, an item would be repaired at the general support level when a general support level maintenance action was the highest level required by the maintenance actions in the shotline. In the baseline run the entire workload associated with this shotline was placed on the general support maintenance unit. However, in the MEMO run, if the general support maintenance action was deferrable or nonessential, the workload migrated forward to the next lower level indicated in the shotline. This was observed on the APC, howitzer and truck, and to a much greater extent on the tank. It accounted for the significant decrease in the operational availability of the tank. It also accounted for increased queues for parts and DX items at forward levels of maintenance in the MEMO run.

It should be noted at this point that although this phenomenon was permitted to occur in the MEMO simulation runs so that the full impact of deferred maintenance available could be observed, it would most likely be precluded by proper management in an actual situation. Specifically, if maintenance workloads exceeded the capabilities of the lower maintenance level, or the time required to accomplish all repairs exceeded a given limit, the item would be evacuated to the next higher echelon. Queues for skills at FDS 01 and RDS are shown in Table III-9. At both levels queues are reduced under MEMO. A discussion of specific MOS utilization is provided after the analyses of the four end items.

THE BDM CORPORATION

TABLE III-9. QUEUES FOR SKILLS (APC)

	FDS 01		RDS	
	<u>BL</u>	<u>MEMO</u>	<u>BL</u>	<u>MEMO</u>
JOB WAITING MEN	0.2	0	5.9	0

b) M-109A1 Howitzer

The application of the MEMO concept to the M-109 howitzer had little impact on operational availability or workloads. This is due primarily to the relatively small deferred maintenance workload on the M-109 and the relatively low density of the end item. Figure III-9 provides the operational availability graph for the M-109 during the baseline and MEMO runs.

Table III-10 portrays the size of the deferred maintenance workload in terms of man-hours as it occurred. Since the M-109 receives most of its direct support maintenance from the rear direct support node, the forward direct support level is not shown.

TABLE III-10. DEFERRED WORKLOAD FOR THE M-109
(MAN-HOURS)

<u>TYPE MAINT ACTION</u>	<u>MAINTENANCE LEVEL</u>			
	<u>ORG 01-04</u>	<u>RDS</u>	<u>GS</u>	<u>DEPOT</u>
DEFERRABLE	5	1251	193	103
NONESSENTIAL	0	0	0	0

Table III-11 indicates the number of jobs actually received during the baseline and MEMO runs. Although some reductions in workloads are apparent during the MEMO run, these reductions are not significant when viewed over the 120-day period.

ANALYST: THE BDM CORP
 DATE: 1/ 7/ 1982
 RUN NAME: BASELINE RUN 1 & 2

*** M109A1 MODEL MACATAK ***
 TRANSACTION FILE ANALYZER

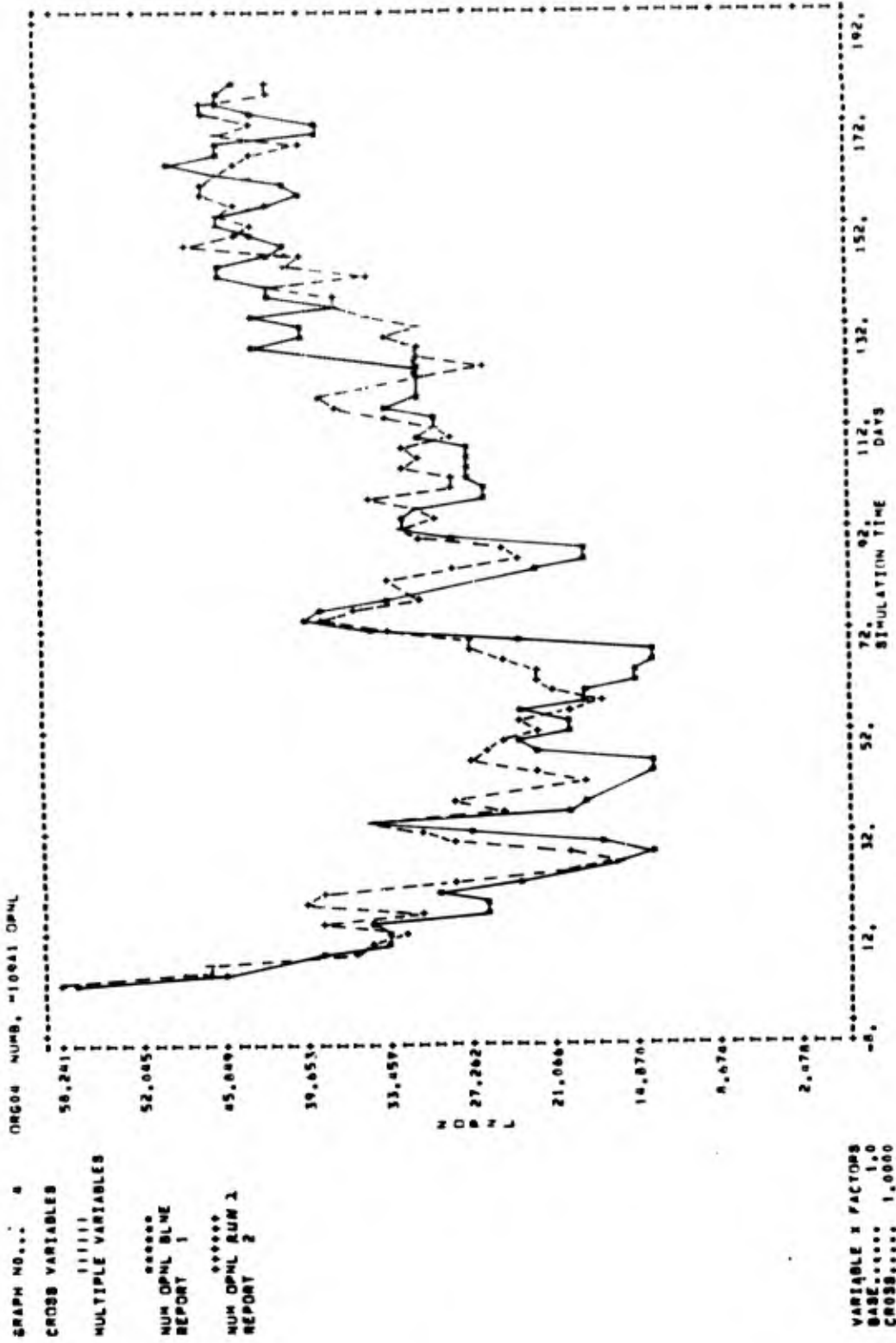

Figure III-9. M109A1 Operational Availability at ORG 04, Baseline vs MEMO

THE BDM CORPORATION

TABLE III-11. NUMBER OF JOBS RECEIVED (M-109)

<u>SIMULATION RUN</u>	<u>MAINTENANCE LEVEL</u>		
	<u>ORG 01</u>	<u>RDS</u>	<u>GS</u>
BASELINE (1)	1262	2429	125
MEMO (2)	1113	2044	84

Since the deferred maintenance workloads are relatively small, little difference was observed in the maintenance turnaround times of the baseline and MEMO runs (Table III-12).

TABLE III-12. MAINTENANCE TURNAROUND TIME (M-109)
(IN DAYS)

<u>TYPE FAILURE</u>	<u>BASELINE</u>	<u>MEMO</u>	<u>DECREASE/ INCREASE</u>
RELIABILITY FAILURE	0.86	0.89	+0.03
COMBAT DAMAGE	5.4	5.4	-

Queues for repair parts and DX items are shown in Table III-13. Although in most cases slight reductions in queues are shown during the MEMO run, these reductions are not significant enough to cause any marked increase in operational availability. The increase in queues for DX and ASL items at ORG 01 are attributable primarily to a forward migration of combat damage workloads during MEMO.

Queues for skills at RDS during the baseline run were an average of 3.4 and were reduced to an average of 1.5 during the MEMO run. However, this decrease in the number of jobs waiting skills is not sufficient enough to cause a marked increase in operational availability when viewed over the 120-day period.

THE BDM CORPORATION

TABLE III-13. QUEUES FOR PARTS AND DX ITEMS (M-109)
(IN NUMBERS OF JOBS)

MAINTENANCE LEVELS AND RUNS

<u>TYPE PARTS</u>	ORG 01		RDS	
	<u>BL</u>	<u>MEMO</u>	<u>BL</u>	<u>MEMO</u>
DX	1	1.7	0.9	0.7
ASL	3.2	4.0	7.0	5.7
NSL	3.0	2.7	3.4	2.6

c) M-60A1 Tank

The performance of the tank in the MEMO run was contrary to expectations. Its operational availability decreased, the workload at FDS increased significantly, turnaround times increased, queues for NSL items at the organizational and forward direct support levels and queues for DX parts at RDS increased significantly. The typical marked decrease in operational availability is shown for node ORG 01 in Figure III-10. On average, ten fewer tanks were available. This reduction is attributable to three factors:

- (1) The distribution of the deferred workload as it occurred over space and time,
- (2) The size of the deferred workload, and
- (3) The forward migration of combat damage workloads when MEMO was applied.

Table III-14 quantifies the distribution of mission essential, deferrable and nonessential maintenance actions as they appear in the contingency maintenance allocation chart (CMAC) in FM 42-9-1 for the M-60A1 tank. The table indicates that most of the deferrable and nonessential maintenance actions which comprise the deferred maintenance workload are properly located at the organizational and direct support level to support MEMO implementation. However, CMACs and MACs do not indicate the frequency of occurrence for the deferred maintenance actions which determines how much the workloads will actually be reduced.

TABLE III-14. CMAC SUMMARY M-60A1

TYPE MAINT. <u>ACTION</u>	<u>MAINTENANCE LEVEL</u>			
	<u>ORG</u>	<u>DS*</u>	<u>GS</u>	<u>DEPOT</u>
MISSION ESSENTIAL	355	112	8	24
DEFERRABLE	26	39	24	0
NONESSENTIAL	69	12	1	0

*CMACs do not differentiate between FDS and RDS.

THE BDM CORPORATION

Table III-15 quantifies the deferred maintenance workload for the M-60A1 tank in terms of man-hours as it actually occurred. This indicates that although the CMAC states that the majority of deferred maintenance actions are performed at the organizational and direct support levels, the majority of maintenance man-hour reductions attributable to deferred maintenance actually occur at the rear direct support and general support levels. The implications of this are shown in Table III-16.

TABLE III-15. DEFERRED WORKLOAD FOR THE M-60A1
(MAN-HOURS)

TYPE MAINT ACTION	<u>MAINTENANCE LEVEL</u>				
	ORG (01-04)	FDS (01-03)	RDS	GS	DEPOT
DEFERRABLE	24	271	857	169	0
NONESSENTIAL	<u>923</u>	<u>777</u>	<u>3357</u>	<u>3221</u>	<u>0</u>
TOTAL DEFERRED	947	1048	4214	3390	0

Table III-16 indicates where the jobs were actually received over space and time during the baseline and MEMO runs. This table when compared to the previous table indicates that when MEMO was applied to the M-60A1, a forward migration of workloads occurred; from GS to the FDS and RDS levels. The greatest increase in the number of maintenance actions received was at the FDS level which accounts for the decrease in operational availability.

TABLE III-16. NUMBER OF JOBS RECEIVED M-60A1

<u>SIMULATION RUN</u>	<u>MAINTENANCE LEVEL</u>			
	<u>ORG 01</u>	<u>FDS 01</u>	<u>RDS</u>	<u>GS</u>
BASELINE (1)	4005	719	1992	1980
MEMO (2)	<u>3382</u>	<u>1109</u>	<u>2080</u>	<u>653</u>
DECREASE/INCREASE	-623	+390	+88	-1327

THE BDM CORPORATION

The forward migration of the workload and the subsequent surge on FDS directly impacts maintenance turnaround times. Table III-17 shows a nearly one-day increase in the average time required to work off combat damage.

TABLE III-17. MAINTENANCE TURNAROUND TIMES (M-60A1)
(IN DAYS)

<u>TYPE FAILURE</u>	<u>BASELINE</u>	<u>MEMO</u>	<u>DECREASE/ INCREASE</u>
RELIABILITY FAILURE	0.06	0.55	-0.05
COMBAT DAMAGE	6.5	7.4	+0.90

Statistics on average queue sizes for parts and DX items indicated that queues actually decreased in most cases during the MEMO period. The only increases occurred at the organizational forward direct support levels for NSL items (Table III-18). These averages are misleading in two important instances: NSL items at FDS and DX items at RDS.

TABLE III-18. QUEUES FOR PARTS AND DX ITEMS (M-60A1)
(NUMBER OF JOBS)

MAINTENANCE LEVELS AND RUNS

<u>TYPE PARTS</u>	<u>ORG 01</u>		<u>FDS 01</u>		<u>RDS</u>	
	<u>BL</u>	<u>MEMO</u>	<u>BL</u>	<u>MEMO</u>	<u>BL</u>	<u>MEMO</u>
DX	0.54	0.45	0.03	0.25	6.7	4.0
ASL	7.7	6.3	2.9	2.5	2.9	2.6
NSL	1.9	2.5	1.4	3.2	11.6	9.8

Since the average queues for parts statistics are averages over the 120 day period, graphs were used to assess the full impact of the NSL queues. The graph of the NSL queue at FDS 01 indicated

THE BDM CORPORATION

that approximately eight more tanks were waiting NSL in the MEMO run than in the baseline. This is shown in Figure III-11. The NSL queues, which were caused by the shift in the workload, are primarily responsible for the decrease in operational availability in Run 2.

The statistics showing the average queues for DX items at rear direct support indicated a substantial decrease under MEMO (from 6.7 in the Baseline to 4.0 during MEMO). However, analysis of the graph indicated that during the MEMO run significant queues for DX items occurred during the first 80 days and also contributed significantly to the degradation of the tank fleet. The graph is shown in Figure III-12.

Due to the impacts of NSL and DX queues during the MEMO run fewer jobs were waiting men, since skills could not be used until the required parts became available (Table III-19). This led to smaller queues for men. In effect, men were waiting for the repair parts they needed.

TABLE III-19. JOBS WAITING MEN (M60A1)

	FDS 01		RDS	
	<u>BL</u>	<u>MEMO</u>	<u>BL</u>	<u>MEMO</u>
JOBS WAITING MEN	2.4	1.3	1.1	1.4

In summary, the forward migration of workloads during the application of MEMO was most pronounced for the M60A1 tank and was the primary cause of the lower operational availability rate during the MEMO simulation run. As previously mentioned this situation could be precluded by good management in an actual situation. In the case of the tank, management intervention would have produced an operational availability rate during the MEMO application period that would have been equal to or exceeded the baseline rate. However, no amount of management can prevent the accumulation of deferred work which builds up under prolonged MEMO periods.

ANALYST., THE BDM CORP
 DATE, 1/ 7/ 1982
 RUN NAME, BASELINE RUN 1 & 2

** MANLOSS MODEL MACATAK **
 TRANSACTION FILE ANALYZER

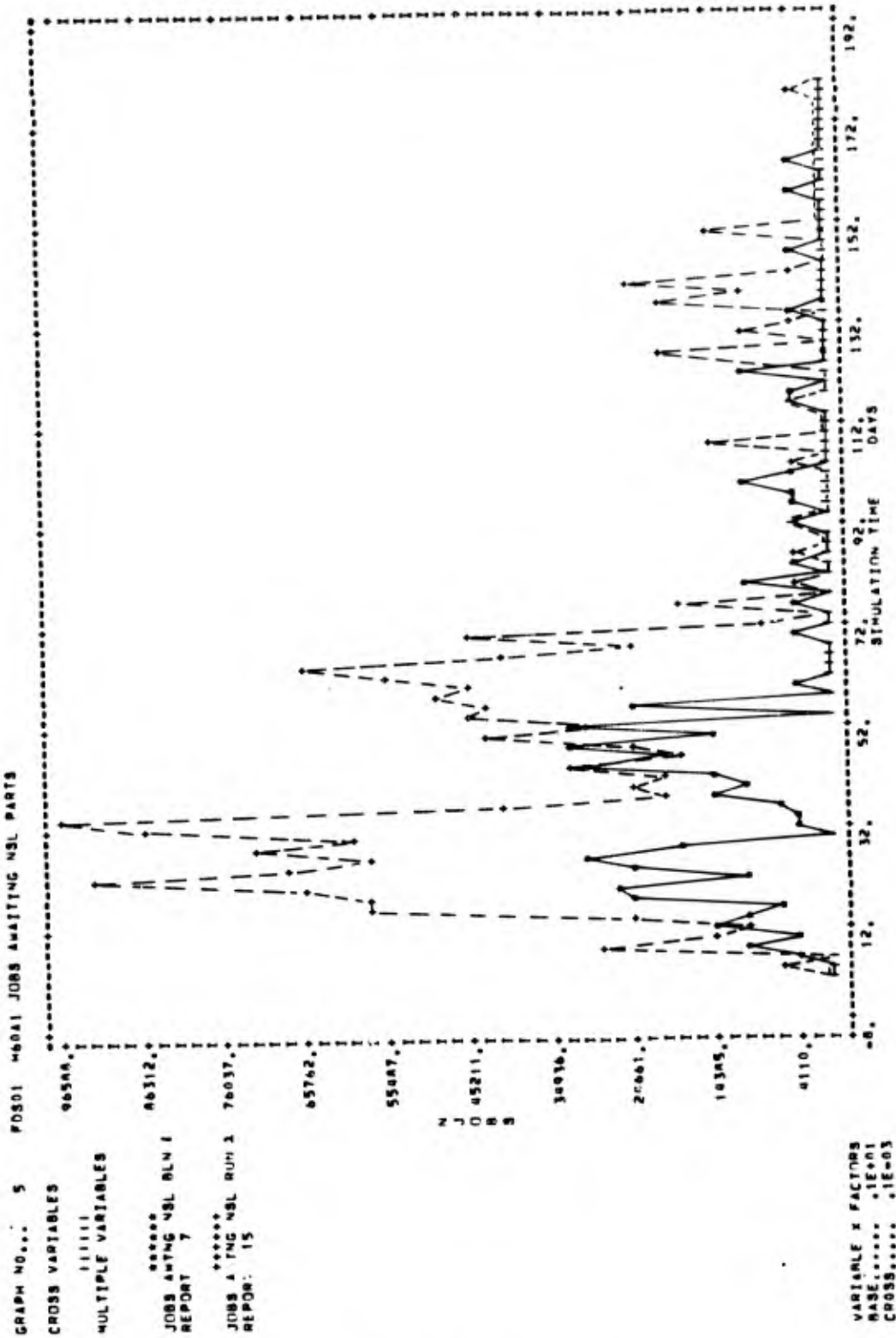

Figure III-11. M60A1 Jobs Awaiting NSL Parts at FDS 01, Baseline vs MEMO

ANALYST, THE BDM CORP
 DATE, 1/ 7, 1982
 RUN NAME, BASELINE RUN 1 & 2

** HAWKINS MODEL MACATAK **
 TRANSACTION FILE ANALYZER

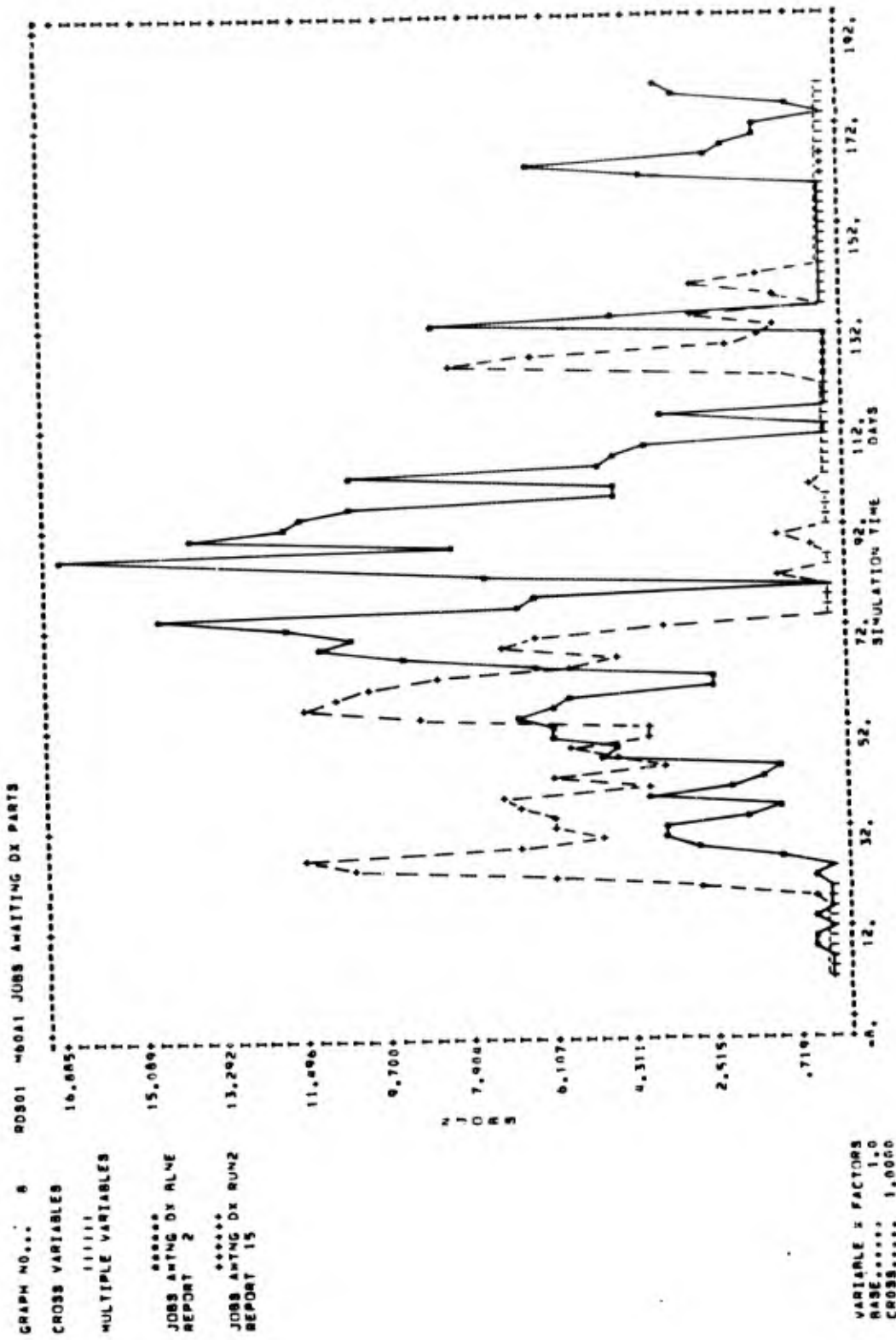

Figure III-12. M60A1 Jobs Awaiting DX Parts at RDS 01, Baseline vs MEMO

THE BDM CORPORATION

d) M813 Truck

The application of MEMO to the truck has little positive effect on operational availability as shown in Figures III-13 and 14. As with the tank, this is attributable to the size of the deferred workload, the distribution of the deferred workload as it occurred over space and time, and the same forward migration of combat damage workloads when MEMO was applied. The forward migration of workloads was far less a factor with the truck than the tank.

Table III-20 quantifies the deferred workload in terms of man hours. At ORG 01 and FDS 01 the size of the workload over the 120 day period was less than one man hour due to the low density of the items and the low frequency of occurrence of deferred maintenance actions. Nearly all of the deferred workload is located at the rear direct support level.

TABLE III-20. DEFERRED WORKLOAD FOR THE TRUCK
(MAN HOURS)

TYPE MAINT <u>ACTION</u>	MAINTENANCE LEVEL				
	<u>ORG 01</u>	<u>ORG 04</u>	<u>FDS 01</u>	<u>RDS</u>	<u>GS</u>
DEFERRABLE	(LESS THAN 1)	97	(LESS THAN 1)	10,835	0
NON-ESSENTIAL	0	0	0	0	0

Table III-21 shows the number of jobs received at each level of maintenance during the baseline and MEMO runs. Very few reductions occur at the organizational and forward direct support levels. This is due primarily to the forward migration of workloads from the rear direct support level to the forward direct support and organizational levels for the truck fleet at ORG 01 and from the rear direct support level to the organizational level at ORG 04.

ANALYST, THE BDM CORP
 DATE, 1/ 7/ 1982
 RUN NAME, BASELINE RUN 1 & 2

OF MANLOGS MODEL MACATK
 TRANSACTION FILE ANALYZE4

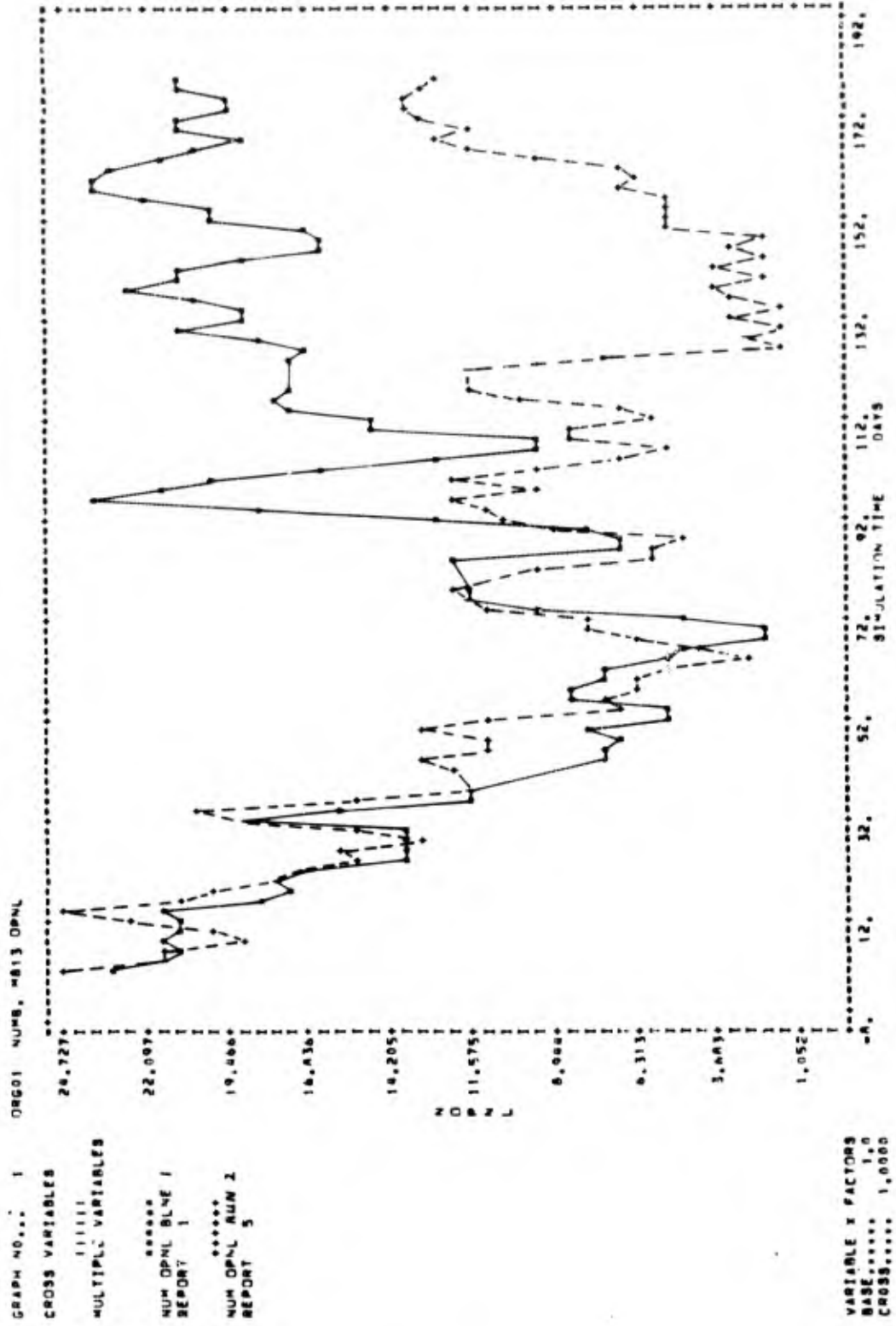

Figure III-13. M813 Operational Availability at ORG 01, Baseline vs MEMO

ANALYST, THE BDM CORP
 DATE, 1/7/1982
 RUN NAME, BASELINE RUN 1 & 2

OR MAPLOGS MODEL MACATAK **
 TRANSACTION FILE ANALYZER

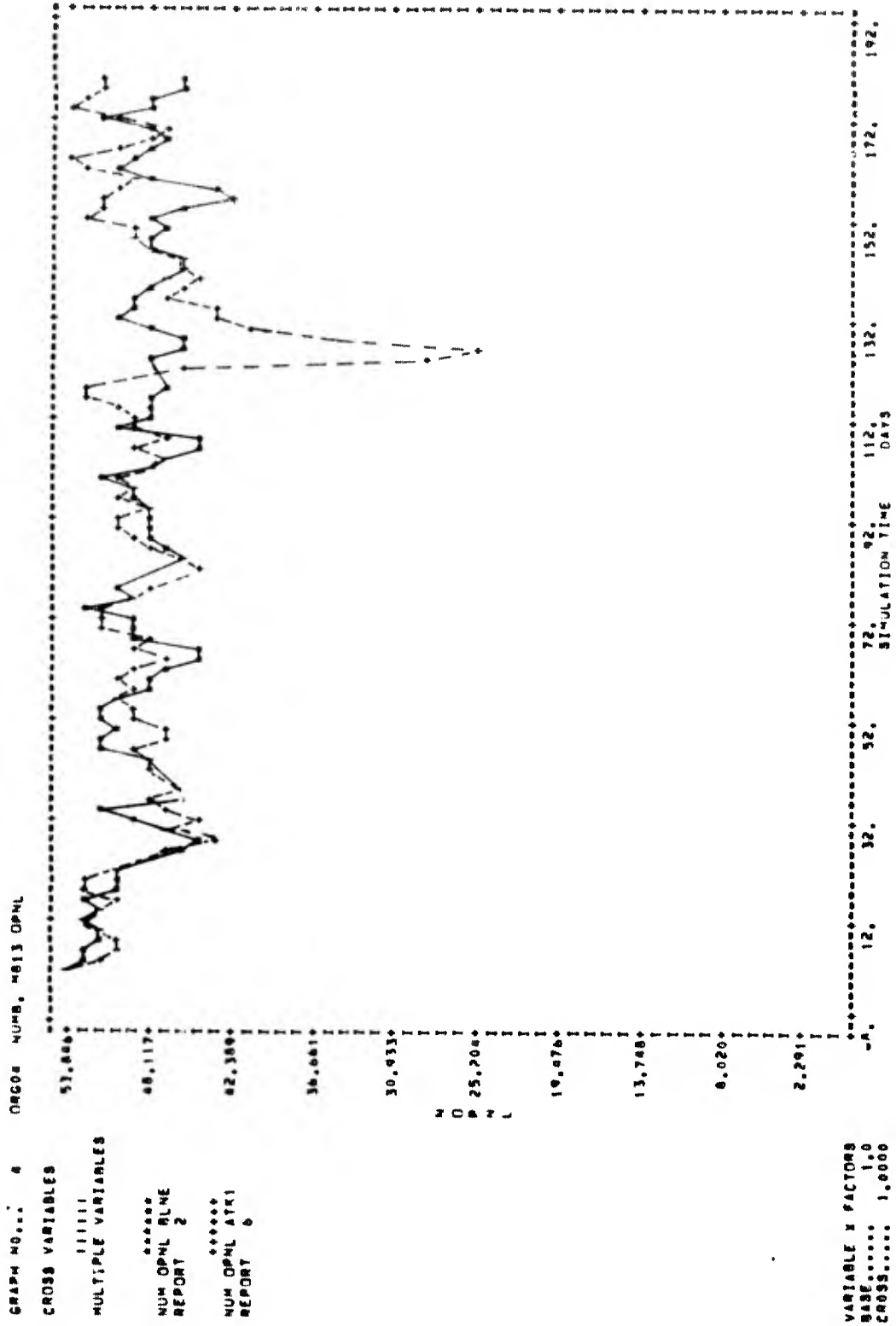

Figure III-14. M813 Operational Availability at ORG 04, Baseline vs MEMO

THE BDM CORPORATION

TABLE III-21. NUMBER OF JOBS RECEIVED (TRUCK)

SIMULATION <u>RUN</u>	MAINTENANCE LEVEL				
	<u>ORG 01</u>	<u>ORG 04</u>	<u>FDS 01</u>	<u>RDS</u>	<u>GS</u>
BASELINE (1)	1,176	2,690	489	2,780	503
MEMO (2)	<u>1,175</u>	<u>2,594</u>	<u>437</u>	<u>1,080</u>	<u>412</u>
DECREASE/INCREASE	-1	-96	-52	-1,700	-91

Maintenance turnaround times were reduced to some extent by MEMO. However, these reductions were not sufficient enough to have marked effect on operational availability (Table III-22).

TABLE III-22. MAINTENANCE TURNAROUND TIMES (TRUCK)
(IN DAYS)

<u>TYPE FAILURE</u>	<u>ORG 01</u>		<u>ORG 04</u>	
	<u>BL</u>	<u>MEMO</u>	<u>BL</u>	<u>MEMO</u>
RELIABILITY FAILURE	0.31	0.30	0.28	0.36
COMBAT DAMAGE	4.7	3.60	7.3	3.3

Statistics concerning queues for parts (Table III-23) and jobs waiting men (Table III-24) indicate some improvement during the MEMO run. However, like the tank, the forward migration of workloads during MEMO caused significant surge requirements for parts that cannot be observed in the averages. This is evidenced by the number of jobs waiting men in Table III-24.

The reduction of jobs waiting men during the MEMO run is caused primarily by queues for parts, since the men cannot perform the repairs until parts are received.

TABLE III-24. JOBS WAITING MEN (TRUCK)

	<u>FDS 04</u>		<u>RDS</u>	
	<u>BL</u>	<u>MEMO</u>	<u>BL</u>	<u>MEMO</u>
JOBS WAITING MEN	3.9	1.8	1.6	0.04

THE BDM CORPORATION

TABLE III-23. QUEUES FOR PARTS AND DX ITEMS (TRUCK)
(AVERAGE NUMBER OF JOBS)

TYPE	MAINTENANCE LEVELS & RUNS							
	ORG 01		ORG 04		FDS 01		PDS	
	<u>BL</u>	<u>MEMO</u>	<u>BL</u>	<u>MEMO</u>	<u>BL</u>	<u>MEMO</u>	<u>BL</u>	<u>MEMO</u>
DX	0.54	1.6	0.34	1.1	0.40	0.13	3.8	0.74
ASL	0.77	1.3	0.27	3.0	1.2	1.1	2.4	1.7
NSL	1.9	0.58	0.44	0.26	0	0	0.22	0.17

2) Utilization of Skills (D to D + 120)

A basic premise of MEMO is that skills will be freed up from deferrable work for more efficient use on mission essential work. Run 2 showed that MEMO had two basic effects on MCS usage. First, Run 2 showed that the MEMO concept did not result in a uniform reduction in workloads for all MOSs. Some experienced substantial reductions; others did not. Run 2 also indicated that without proper management of the forward migrating workload, some MOSs will actually see an increase in their work under MEMO. Second, there is a definite pattern among echelons: the higher the echelon, the more MOSs which experienced workload reductions. This means that (1) better utilized MOSs tend to be repairing reparable rather than end items, and (2) forward echelons MOSs, whose work is generally directed toward repair of end items, are not aided by a long-term application of MEMO.

It should be noted up front that any reductions in work should not be viewed as savings since the deferred workloads must be accomplished at the end of the MEMO period. This is discussed in the D + 121 to D + 180 analysis.

Since some MOSs work on more than one of the end items examined in this study, Run 2 results are generally not discussed in terms of specific end items.

.) MEMO Impact on Skills at FDS (D to D + 120)

At FDS, the MOSs fall into two categories. In category one are those with little or no reduction in workloads attributable to deferred maintenance. These MOSs and their workloads are listed in Table III-25. FDS 01 was chosen because results there are typical of results at all FDS nodes.

Some workloads actually increase from D to D + 120. These increases occur because of the forward movement of maintenance under MEMO. None of the increases actually increased the average man busy by more than one man (2080 hours).

THE BDM CORPORATION

TABLE III-25. MOSs NOT AFFECTED BY MEMO

MOS	MAN-HOURS		PERFORMED
	<u>RUN 1</u>		<u>RUN 2</u>
11B INFANTRYMAN (M-113)	0		0
13B CANNON CREWMAN (M-109)	0		0
*19E M-60 ARMOR CREWMAN	522		1522
31E FIELD RADIO REPAIRER	41		287
41C FIRE CONTROL INSTRUMENT REPAIRER	1427		1316
43M FABRIC REPAIR SPECIALIST	0		0
44B METAL WORKER	257		303
44E MACHINIST	71		123
45B SMALL ARMS REPAIRER	73		69
45K TANK TURRET REPAIRER	3685		4603
45L ARTILLERY REPAIRER	0		0
63B LT WVEH & PWR GEN MECHANIC	3340		3083
63C HV WHEEL VEHICLE MECHANIC	0		0
63W WHEEL VEHICLE REPAIRER	1536		1282
*64C MOTOR TRANSPORT OPERATOR (M-813)	138		105

*These MOSs are not authorized at FDS. The statistics indicated the amount of organizational level maintenance performed at FDS due to combat damage worked off at FDS.

In category two are the two MOSs for which MEMO reduces the average number of men busy, but only by small amounts. These are summarized in Table III-26.

TABLE III-26. MOSs AT FDS WITH SOME REDUCTION IN MANPOWER ACHIEVED (D TO D + 120)

MOS	AVERAGE BUSY		MAN-HOURS PERFORMED	
	<u>RUN 1</u>	<u>RUN 2</u>	<u>RUN 1</u>	<u>RUN 2</u>
63H	2.3	2.1	6601	6605
63G	1.1	.27	3282	753

The savings in terms of men on average are less than 1 in both cases. The average utilization of the 63G shown in Figure III-15 demonstrates how man-hour differences, which appear to be significant, are not necessarily translated directly into manpower savings.

In summary, MOS utilization is scarcely improved under a long MEMO period. Workloads can actually increase and lower the operational availability of end items supported. All MOSs at FDS are considered to be critical.

b) MEMO Impact on Skills at RDS (D to D + 120)

At RDS, the MOSs fall into two categories. First are the MOSs scarcely used and those whose utilization is not improved by MEMO. Table III-27 lists these MOSs and their RDS workloads. The table shows the critical MOSs, i.e., those whose profile is not improved under MEMO, to be the 63H, 41C, and 45L. These three MOSs at RDS are working on the M-109A1 and the M-113A1. The 45L works exclusively on the M-109A1.

In category two at RDS are the 63Y, 63G, 44B, 63W, and 63B. For these MOSs at RDS, workloads are significantly reduced under MEMO. These are translated into manpower savings of one to three men on average only for the 44B, 63W, and 63B, as shown in Table III-28.

** MAILLOGS MODEL MACATAK **
 ANALYST: THE BDM CORP
 DATE: 11 / 7 / 1982
 RUN NAME: BLNE/RUN 2/RUN 3
 TRANSACTION FILE ANALYZER

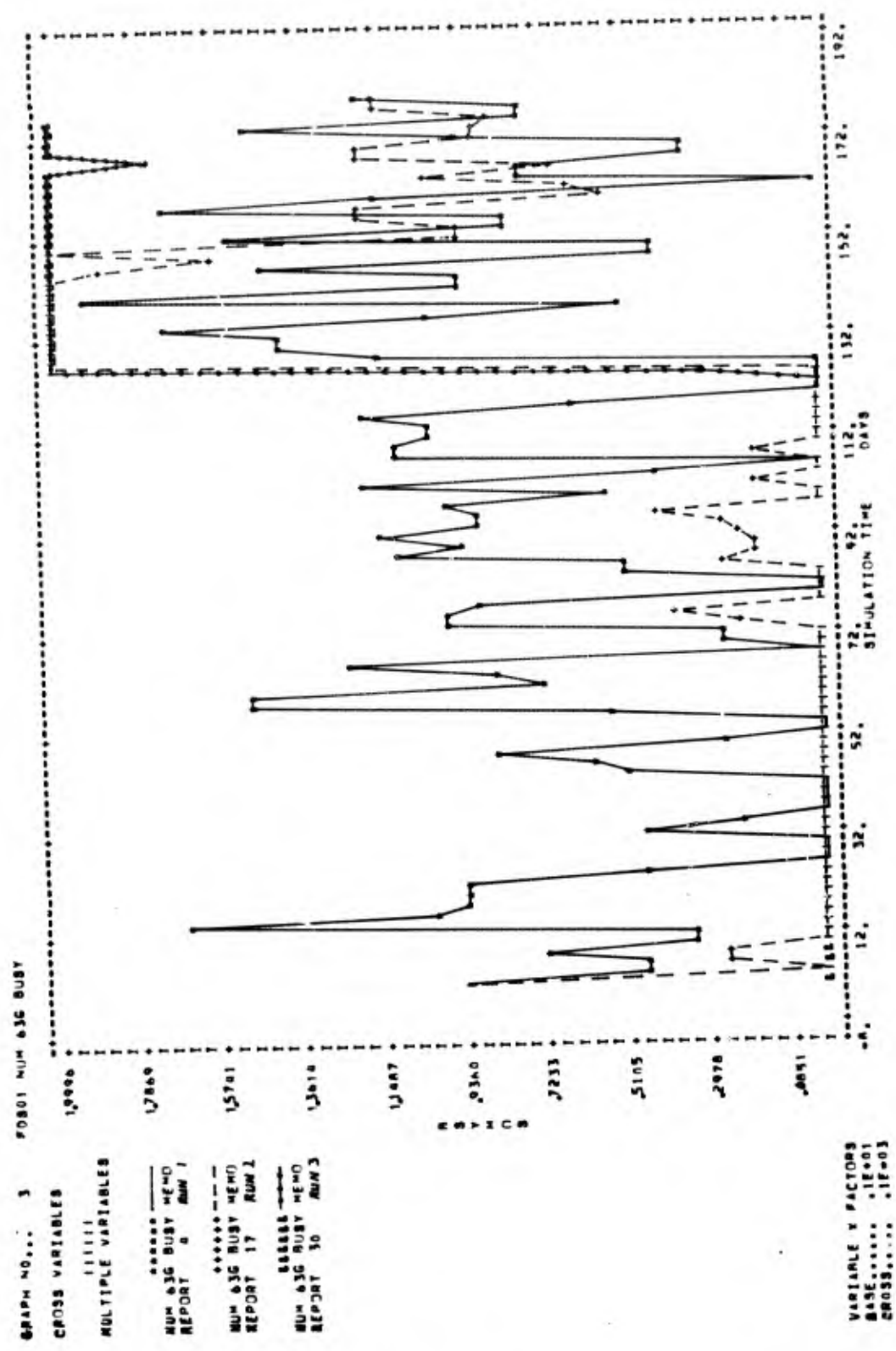

Figure III-15. Number of 63G Busy at FDS 01

THE BDM CORPORATION

TABLE III-27. MOSs AT RDS WITH NO IMPROVEMENT
UNDER MEMO (D TO D + 120)

MOS	AUTHORIZATION	AVG BUSY		MAN-HOURS PERFORMED	
		RUN 1	RUN 2	RUN 1	RUN 2
* 11B	100	0.0	0.0	0	0
* 13B	100	.11	.04	290	162
* 19E	100	.21	.43	614	1054
31E	2	.42	.52	1130	1346
**41C	8	3.1	3.1	8812	8785
43M	1	.23	.09	650	245
44E	2	.44	.38	1242	1071
45B	1	.02	.01	69	27
**45L	8	6.8	6.3	19,593	18,178
**63H	30	5.6	5.8	16,139	16,558
63S	10	.18	0.0	505	0
* 64C	100	.07	.04	1969	7

* The 11B (Infantryman), 13B (Cannon Crewman), 19E (M-60 Crewman) and 64C (Motor Transport Operator) are not authorized at RDS. The statistics indicate the amount of organizational level maintenance performed at RDS due to combat damage worked off at RDS.

**Critical MOSs at RDS

The 63W and 63B are associated with the M-813 at RDS, while more than one half of the 44B is associated with the M-813 the rest is divided among the other end items.

TABLE III-28. MOSs AT RDS WITH WORKLOAD REDUCTIONS
UNDER MEMO (D TO D + 120)

<u>MOS</u>	<u>AUTHORIZATION</u>	<u>AVG BUSY</u>		<u>MAN-HOURS PERFORMED</u>	
		<u>RUN 1</u>	<u>RUN 2</u>	<u>RUN 1</u>	<u>RUN 2</u>
44B	4	2.6	.80	7397	2180
63B	15	4.8	1.2	13,762	3460
63G	8	1.2	.93	3506	2673
63W	16	6.7	5.2	19,213	14,921
63Y	10	1.0	.57	2937	1594

Figure III-16 shows the significant improvement in the 63B for D to D + 120.

c) MEMO Impact on Skills at GS (D to D + 120)

The MOSs at GS fall into two very distinct classes: those unaffected by MEMO and those with significant manpower savings in D to D + 120. In category one, the critical MOSs, are those listed in Table III-29. This table has to be read differently than the previous MOS tables. As previously reported, the availability of skills at GS was unconstrained in all simulation runs. This means that the requirement for each MOS is given in the "MAX BUSY" column.

The second category of MOSs at RDS consists of those for which there is considerable manpower savings in D to D + 120. These reductions must not be viewed as savings since there will be great surges in requirements for them in D + 121 to D + 180 as shown later. These MOSs are tabulated in Table III-30.

ANALYST: THE BDM CORP
 DATE: 1/ 7/ 1982
 RUN NAME: BLNE/RUN 2/RUN 3

** MANLOGS MODEL MACATAK **
 TRANSACTION FILE ANALYZER

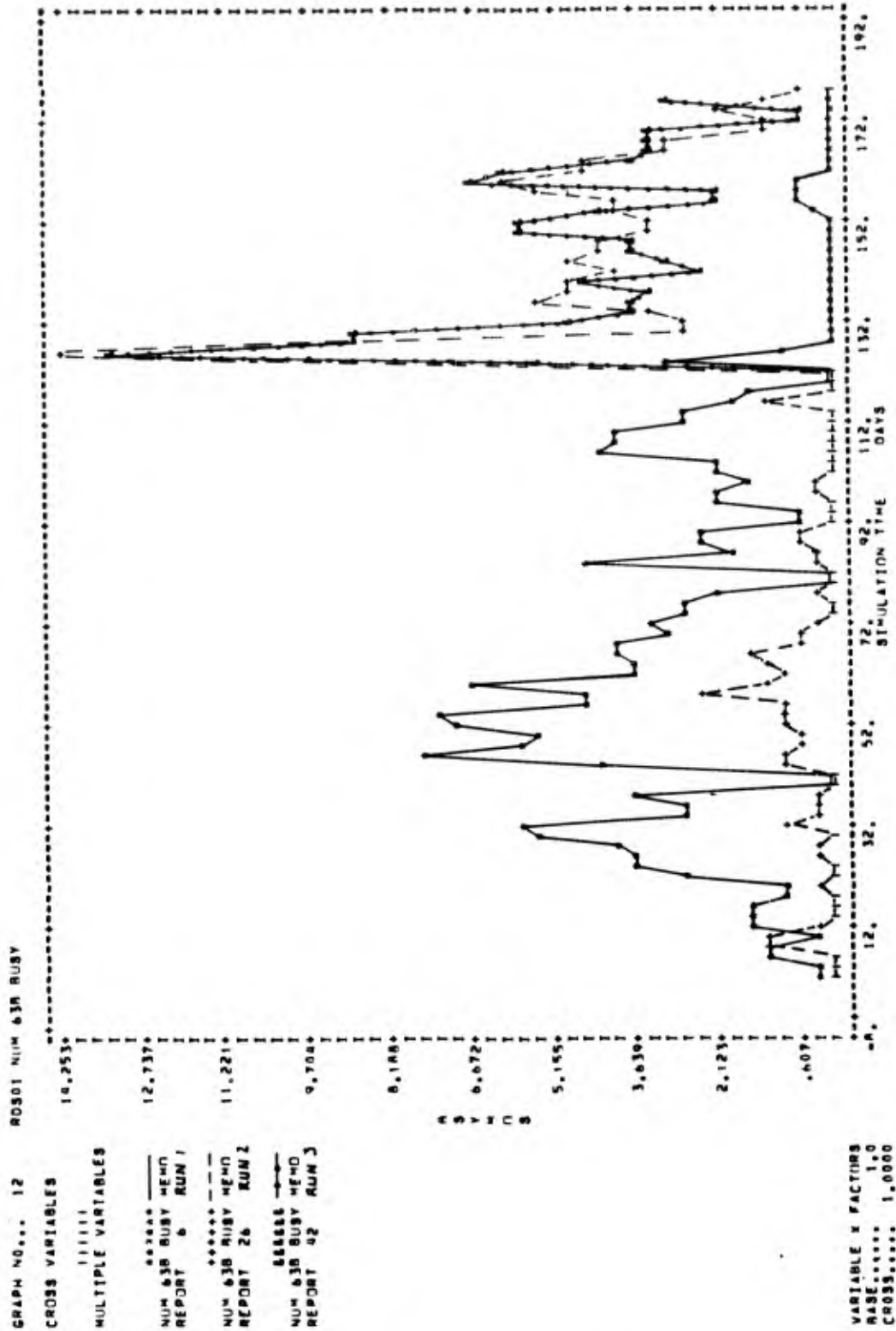

Figure III-16. Number of 63B Busy at RDS 01

THE BDM CORPORATION

TABLE III-29. MOSs AT GS UNAFFECTED BY MEMO
(D TC 5 + 120)

MOS	TOE AUTH	AVG BUSY		MAX BUSY		MAN-HOURS PERFORMED	
		RUN 1	RUN 2	RUN 1	RUN 2	RUN 1	RUN 2
*11B	0	0.0	0.0	0	0	0	0
*13B	0	0.0	0.0	0	0	0	0
*31E	0	.36	.17	4	3	782	408
41C	7	.41	.33	6	5	1171	964
43M	0	0.0	0.0	0	0	0	0
44E	8	.22	.13	4	2	512	228
45B	3	.0003	0.0	1	0	3	0
45L	4	.47	.30	6	6	1337	797
63B	14	.16	.12	4	4	437	310
*63S	0	0.0	0.0	0	0	0	0
63W	40	1.6	1.2	11	10	4522	3490
*64C	0	.05	.04	2	2	146	103

*The 11B (Infantryman), 13B (Cannon Crewman), 63S (HV Wheel Vehicle Mechanic), 31E (Field Radio Repairer), and 64C (Motor Transport Operator) are not authorized at GS. The statistics reflect the amount of organizational maintenance performed at the GS level as a result of combat damage worked off there.

THE BDM CORPORATION

TABLE III-30. MOSs AT GS WITH REDUCED REQUIREMENTS
UNDER MEMO (D TO D + 120)

MOS	TOE	AVG BUSY		MAX BUSY		MAN-HOURS PERFORMED	
	AUTH	RUN 1	RUN 2	RUN 1	RUN 2	RUN 1	RUN 2
63Y	0	2.0	3.0	16	3	4245	208
63H	48	6.1	2.9	38	18	17,256	8072
63G	9	.53	.30	6	3	1540	861
*19E	0	.70	.04	12	4	1507	58
44B	8	1.4	.16	10	3	3351	393
45K	11	3.1	.83	16	7	7719	2331

*The 19E (M-60 Crewman) is not authorized at GS. The statistics in the table indicate the amount of organizational level maintenance that would have to be performed at the GS level by other MOSs. This is a result of combat damage worked off at GS.

At GS, the 19E, 44B, 45K, 63H, and 63Y are largely involved with the M-60A1. This chapter has already addressed the effect of deferring their work on operational availability, i.e., the forward migration problem. The work for the 63G is divided nearly equally between the M-60A1 and the M-813. One other point needs to be made about the man-hours and men "saved" at GS. Since GS work tends to address the repair of reparable and not of end items, the decreases in utilization shown in Table III-30 do not directly affect the operational availability of end items. Furthermore, the savings associated with deferred repair of reparable may not actually be realized depending on current demand for them. That is, reparable which are in short supply must be fixed then, not put off.

In summary, for the items in this study, long-term application of MEMO improves skill utilization only at rear echelons, not forward where repair of end items is most likely to be effected. MOS requirements can be reduced for the MEMO period but the savings may not be

realized in practice. The GS work deferred will also overwhelm the maintenance system, as will be shown in the D + 121 to D + 180 analysis.

c. Impacts of the Deferred Maintenance Workload (D + 121 to D+ 180)

The results of the simulation runs indicated that continuous long-term application of the deferred maintenance MEMO concept will produce maintenance backlogs and surge requirements for DX items, ASL, NSL and maintenance skills that overwhelm the maintenance and supply systems. Secondly, analyses of deferred maintenance actions indicated that long-term application of a deferred maintenance concept will also cause an increase in the mission essential maintenance workload. For example, long-term deferment of relatively simple maintenance actions that could cause a potential failure or prolonged the life of a part or component, can result in the failure of the component and damage to other components as well. This will place an additional burden on both the maintenance and supply systems by increasing demands for parts, skills and replacement components and also by increasing the time required to repair and return the end item to service.

1) Condition of the Equipment at D + 121

Table III-31 provides a summary of the average condition of the end items at the end of the MEMO application period in Runs 2 and 3. The reductions in the average number of deferred maintenance actions in Run 3 is attributable to the number of nonessential maintenance actions associated with the end item. The "Number of Vehicles with Deferred Maintenance" column shows that the nonessentials for the M-813, M-109A1, and the M-113A1 are not a significant part of the total deferred workload. The large percentage of nonessential work for the M-60A1 is clearly seen in the decrease in vehicles with deferred work and in the number of jobs to be performed on each.

TABLE III-31. SUMMARY OF DEFERRED MAINTENANCE

END ITEM	NODE	RUN 2		RUN 3	
		TOTAL VEH W/DEFERRED MAINT AT D+120	AVG NO. OF MAs* PER VEH	TOTAL VEH W/DEFERRED MAINT AT D+120	AVG NO. OF MAs PER VEH
M-60A1	ORG 01	56	7	37	2
M-813	ORG 01	12	30	12	30
M-109A1	ORG 04	31	12	31	12
M-113A1	ORG 01	129	12	129	11

*Maintenance Actions

2) Operational Availability (D + 121 to D + 180)

A marked decrease in the operational availability of end items was observed at the beginning of the D + 121 to D + 180 period during Run 2. (Figures III-8, 9, 10, 13, and 14 previously shown.) This reflected the initial response of the maintenance system to the deferred maintenance workload that had been accumulated over the D to D + 120 MEMO application period. In Run 2, the deferred maintenance workload consisted of deferrable and nonessential maintenance actions. Run 3, in which nonessential maintenance actions were ignored, was made to observe the impact of deferrable maintenance actions accumulated over the D to D + 120 period. Since the distribution and occurrence of deferred maintenance varied from end item to end item, the impacts of deferred maintenance workloads are discussed separately for each.

Operational availability graphs which depict the results of simulation Runs 1, 2 and 3 are discussed in subsequent paragraphs for each end item. Discussions focus on the D + 121 to D + 180 period in which the deferred maintenance workload was placed on the maintenance system. While the graphs permit the initial impact of the deferred maintenance workload to be observed during the first few days of the D + 121 to D + 180 period, they should not be used to interpret the

THE BDM CORPORATION

ability of the maintenance system to work off the backlog. This is due to the manner in which the availability of skills was treated at the general support level.

The MACATAK model was modified to determine the number of each MOS that would be required to accommodate the general support maintenance workload. This was done by placing an unlimited number of each MOS at the general support level. This resulted in all general support maintenance actions being accomplished without queues for skills. The number of each MOS required over space and time to accomplish the workload without delay was recorded. It also resulted in workloads being accomplished in much less time than would have been possible had the availability of skills at the general support level been constrained by unit TOE authorizations. General support skill utilization is discussed in Paragraph 6(3).

a) Impacts of Deferred Maintenance on the
M-113A1 (D + 121 to D + 180)

The initial impacts of the deferred maintenance workload were observed between days 121 and 125 of the operational availability graphs of Runs 2 and 3 (Figure III-17). The average number operational drops from 123 in the baseline to 68 in Run 2 and 89 in Run 3. The decrease in availability was less for Run 3 due to the elimination of nonessential maintenance actions. The relatively fast recovery rate is due to the way GS skills were handled. In order to measure the requirement for skills at GS, unlimited manpower was made available. If GS MOS authorizations were restricted to TOE authorizations, the availability of the M-113A1 could be expected to drop to 68 in Run 2 and 89 in Run 3 and stay near those levels due to the great surges in MOS requirements.

The decrease in operational availability in Runs 2 and 3 does not mean that all vehicles with deferred maintenance were automatically deadlined at the end of the MEMO application period (D + 120). Deferred maintenance backlogs were worked off on each vehicle as they were brought into the maintenance shop when reliability failures

ANALYST, THE BDM CORP
 DATE, 1/ 7/ 1962
 RUN NAME, BLME/RUN 2/RUN 3

** MANLOGS MODEL MACAT:Y **
 TRANSACTION FILE ANALYZER

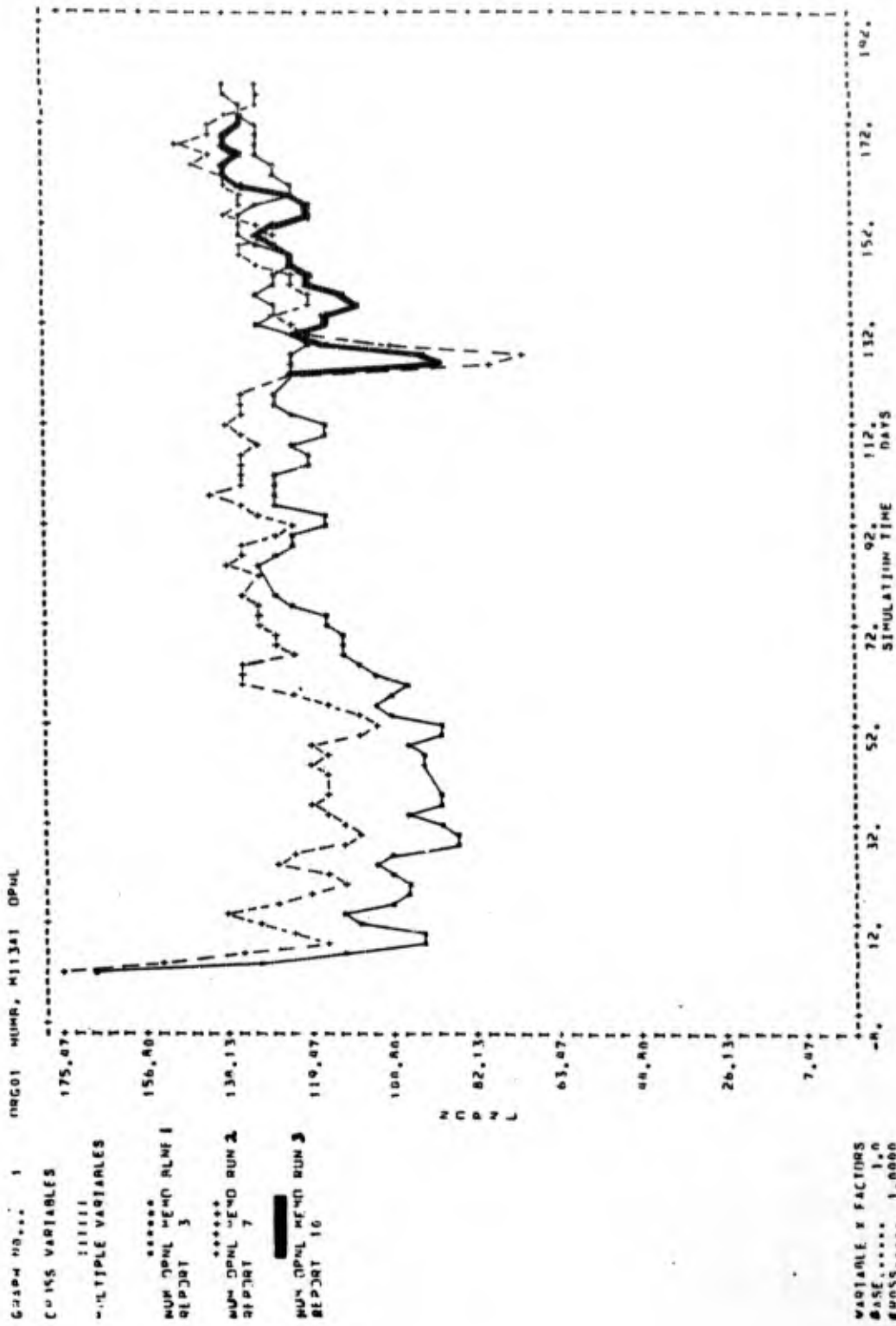

Figure III-17. Impacts of Deferred Maintenance - M113A1 at ORG 01

occurred after D + 120. The decrease in operational availability is attributable to the rate at which the maintenance system was capable of accomplishing the deferred maintenance actions. The sudden decrease in operational availability between D + 121 and D + 125 indicates that the maintenance system was overwhelmed.

The additional time required for the maintenance system to recover caused some deferred maintenance actions to be deferred considerably beyond the 120 day period. As previously mentioned these additional delays can result in an increase of mission essential maintenance as more serious failures stem from the excessive period in which maintenance actions were deferred.

b) Impacts of Deferred Maintenance on the M-109A1 (D + 121 to D + 180)

The initial impacts of the deferred maintenance workload were observed between days 121 and 125 of the operational availability graphs for Runs 2 and 3 (Figure III-18). The decrease in operational availability was actually greater for Run 3 as the elimination of nonessential maintenance actions caused some forward migration of workloads. The remainder of the D + 121 to D + 180 period showed relatively little difference between Runs 1, 2 and 3 since the deferred maintenance workload for the M-109A1 was relatively small.

c) Impacts of Deferred Maintenance on the M-60A1 (D + 121 to D + 180)

The initial impacts of the deferred maintenance workload for the M-60A1 were observed between days 121 and 130 (Figure III-19). The significant difference between Runs 2 and 3 is due to the makeup of the deferred workload on the M-60A1. In Run 2 the operational availability fell to an average of 30 vehicles between day 121 and 125, since the deferred workload consisted of deferrable and nonessential maintenance actions. However, since nearly all of the deferred maintenance workload for the M-60A1 consisted of nonessential maintenance actions, operational availability increased to an average of 66 vehicles in Run 3 since nonessentials were eliminated.

ANALYST: THE BDM CORP
 DATE: 1/ 7/ 1982
 RUN NAME: BLNE/MUN 2/MUN 3

** MATHLOS MODEL MACATA* **
 TRANSACTION FILE ANALYZER

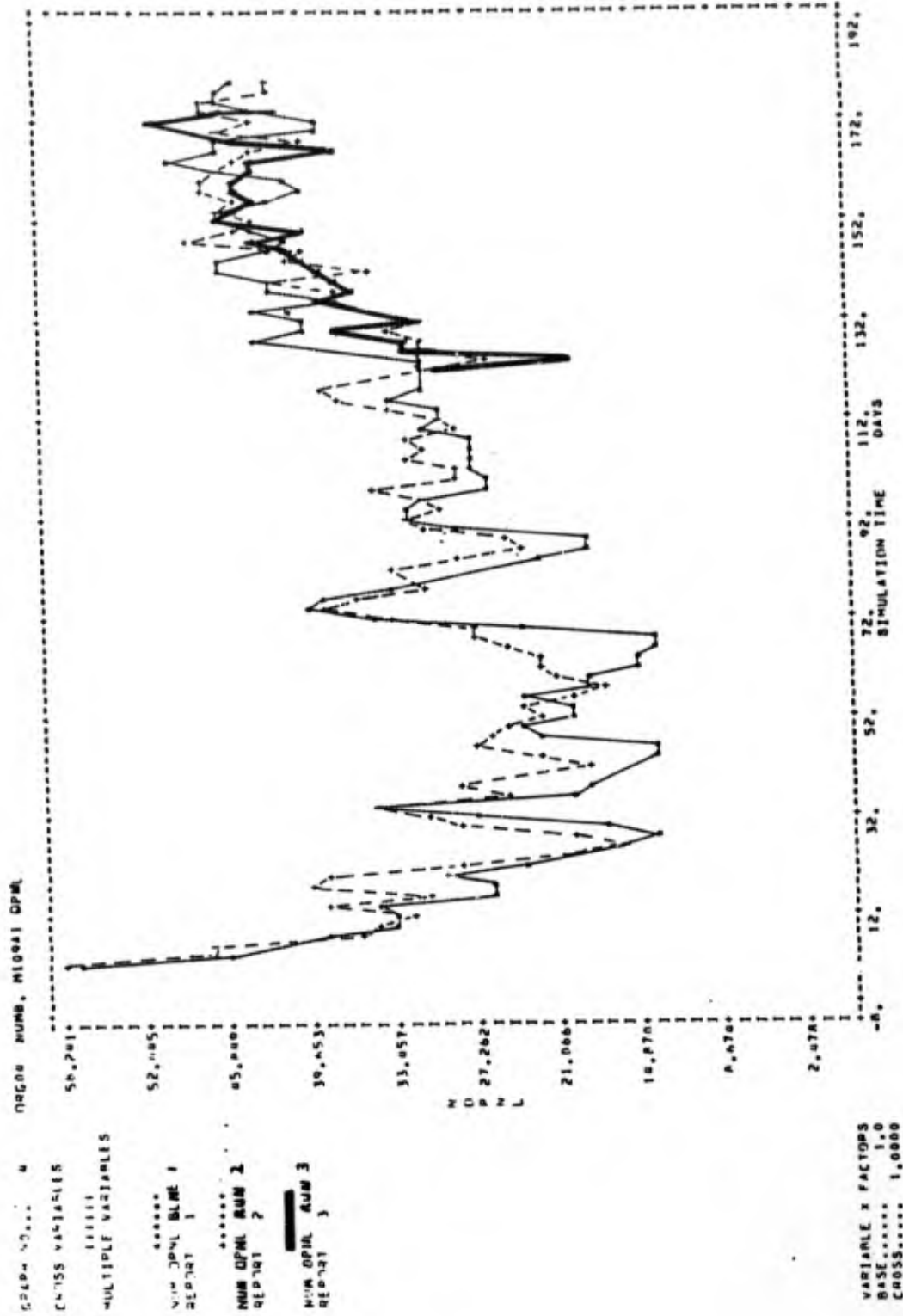

Figure III-18. Impacts of Deferred Maintenance - M109A1 at ORG 01

ANALYST, THE BDM CORP
 DATE, 1/ 7/ 1982
 RUN NAME, BLME/RUN 2/RUN 3

** MAILLOGS MODEL MACATAK **
 TRANSACTION FILE ANALYZER

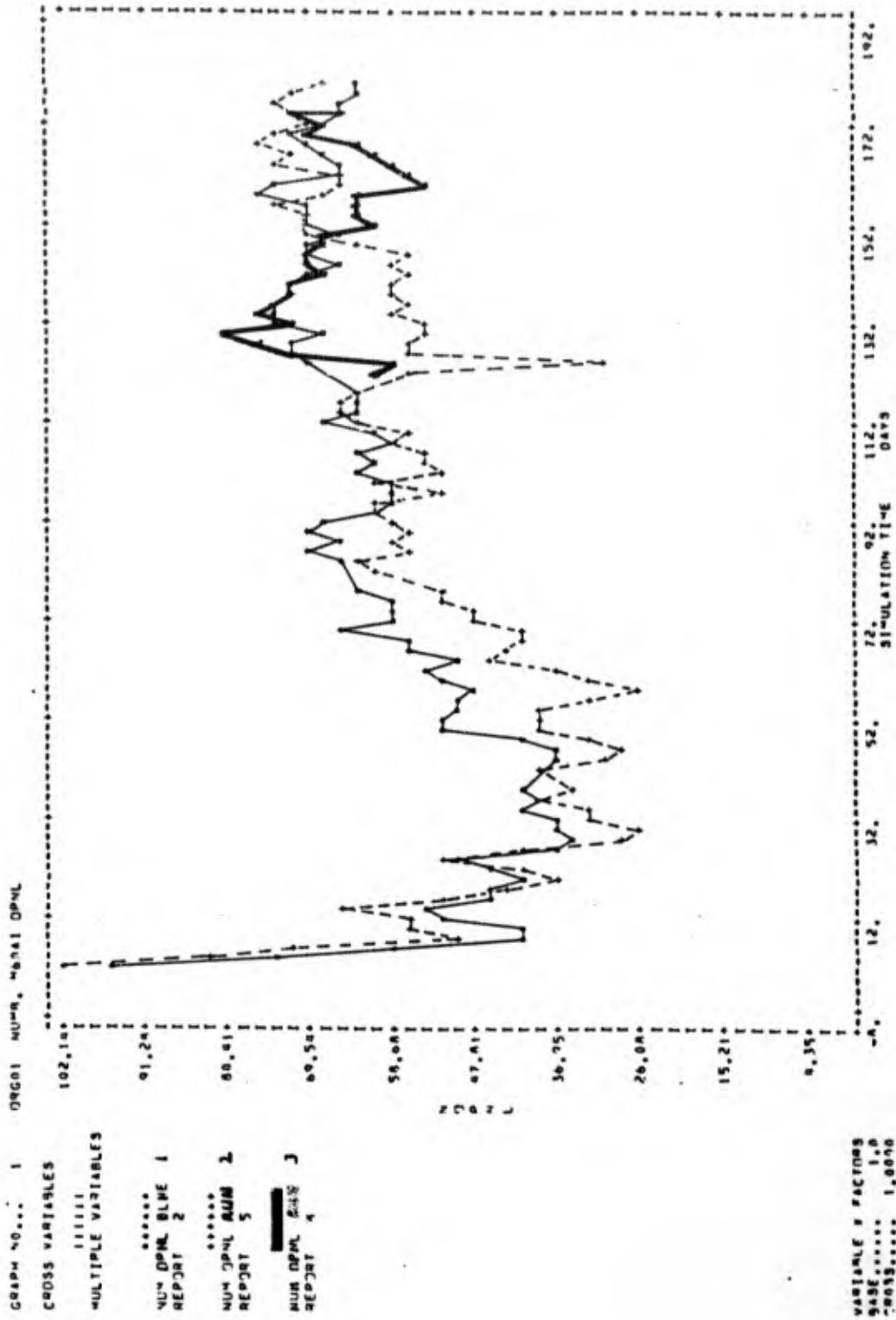

Figure III-19. Impacts of Deferred Maintenance - M60A1 at ORG 01

d) Impacts of Deferred Maintenance on the M-813 (D + 121 to D + 180)

The initial impacts of the deferred maintenance workload for the M-813 were observed between D + 121 and D + 130 (Figure III-20). There was little difference between Runs 2 and 3 since nearly all of the deferred maintenance on the M-813 consisted of deferrables which were worked off in both runs.

3) Queues for DX Items and Parts (D + 121 to D + 180)

The long-term application of a deferred maintenance concept poses a particular dilemma where parts are concerned. If units requisition parts required to perform deferred maintenance actions as they occur during the period where actions are deferred, the accumulation of parts will rapidly exceed the units' ability to carry them. Secondly, if the units defer the requisition of parts until the deferred maintenance actions are to be worked off, the surge in demands will overwhelm the supply and maintenance systems causing queues for DX items and parts.

In the simulations, DX items and repair parts were not requested for deferred maintenance actions until D + 121 to D + 180 when the deferred maintenance backlog was worked off. This was done to measure the impacts of surge requirements expressed in terms of queues for DX, ASL, and NSL items. Graphs showing some of the most significant queues are shown in Figures III-21 through 24. The delays indicated on the graphs will be considerably longer than in the simulation runs since OST, for ASL and NSL were adjusted to make the simulations possible. These adjustments are discussed in Paragraph C.

Queues for NSL items deserve particular attention. Analysis of the shotlines and results of the simulation runs indicated that demands for NSL items will increase during combat. Since NSL items are not stocked in overseas theaters, delays considerably longer than those indicated in the graphs will result. These delays are attributable to the OSTs which are currently 60 to 90 days for NSL items. Even if the NSL items were provided by ALOC, the OST would be from 20 to 30 days at best, based upon current experience. Even with the "in theater" OST of 4 to 8

ANALYST, THE BDM CORP
 DATE, 1/ 7/ 1982
 RUN NAME, BLNE/RUN 2/RUN 3

** NAMELOGS MODEL MACATAK **
 TRANSACTION FILE ANALYZER

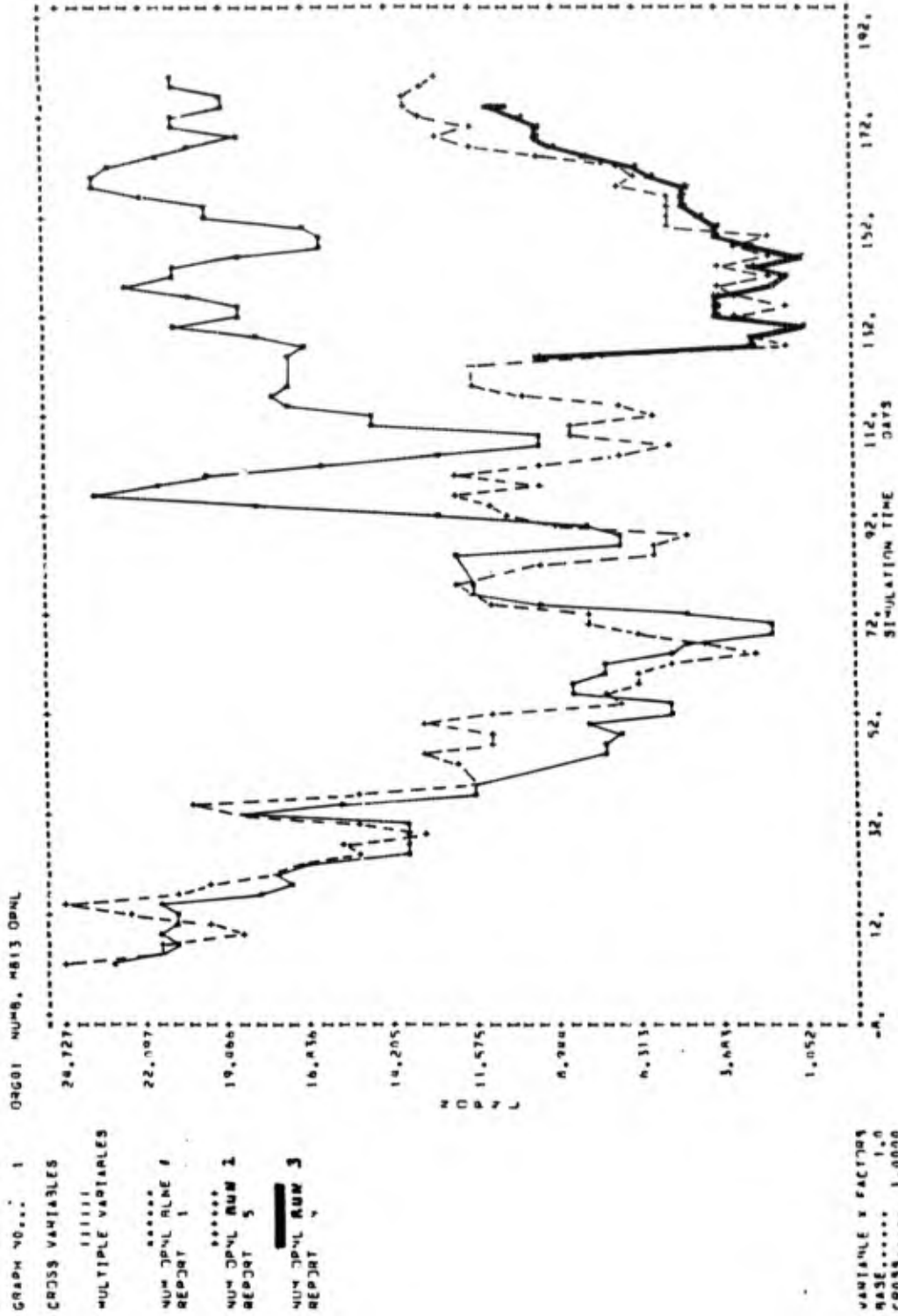

Figure III-20. Impacts of Deferred Maintenance - MB13 at ORG 01

ANALYST, THE BDM CORP
 DATE, 1/ 7, 1982
 RUN NAME, BLN/RUN 2/RUN 3

** HAWKINS MODEL MACATAK **
 TRANSACTION FILE ANALYZER

GRAPH NO... 5 FDS01 M113A1 JOBS AWAITING NSL PARTS

CROSS VARIABLES
 21,562*

MULTIPLE VARIABLES

 JOBS AMTNG NSL BLN 1
 REPORT 5 19,268*

 JOBS AMTNG NSL RUN 2
 REPORT 17 16,970*

 JOBS AMTNG NSL RUN 3
 REPORT 26 14,681*

N
 J 0 10,093
 B 8
 S 5

7,790*

5,505*

3,211*

.918*

VARIABLE X FACTORS
 RATE..... 1.0
 CROSS..... 1,000

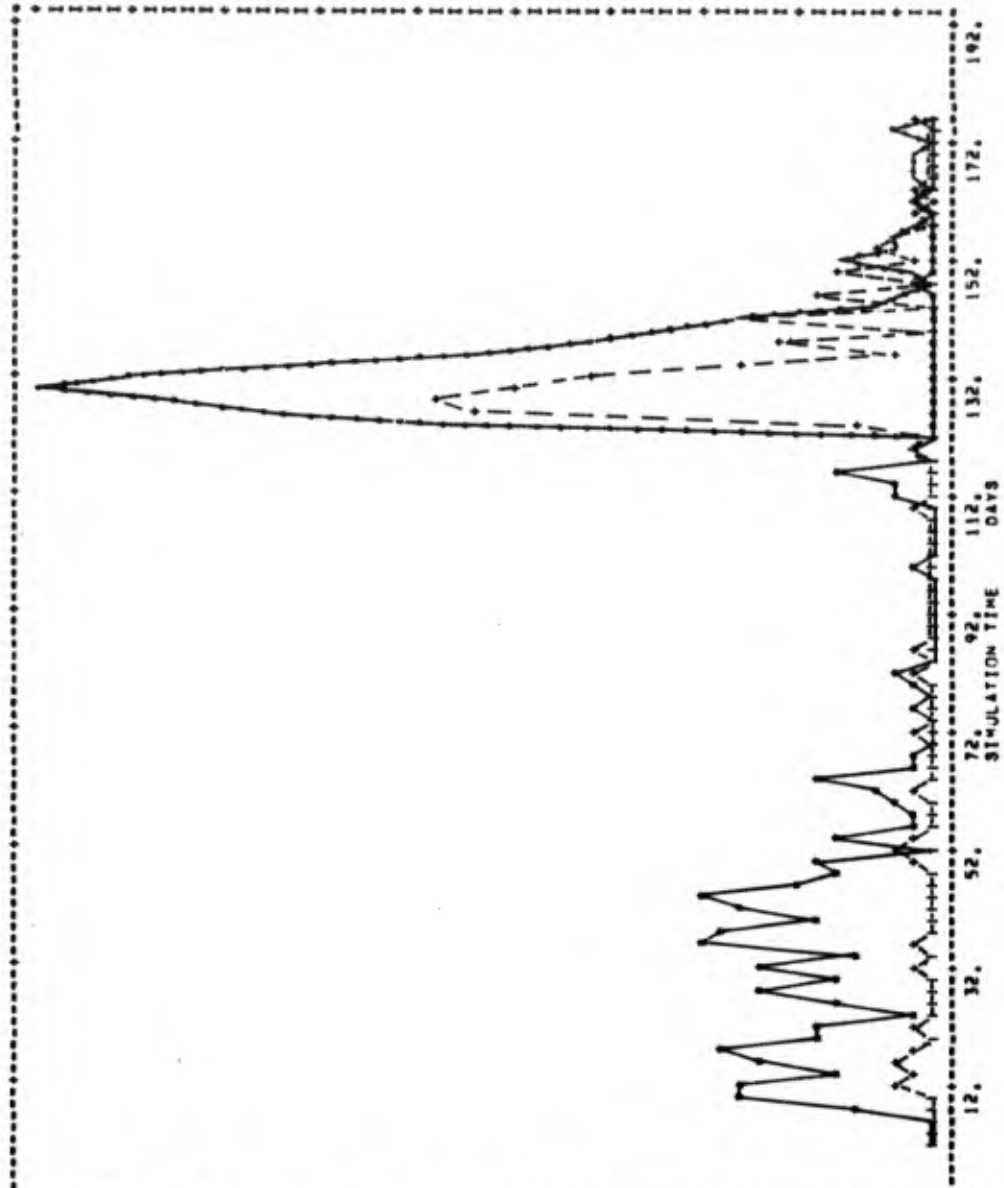

Figure III-21. M113A1 Jobs Awaiting NSL Parts at FDS 01

ANALYST: THE BDM CORP
 DATE: 1/ 7/ 1962
 RUN NAME: BLNE/RUN 2/RUN 3

** MAWLOS MODEL MACATAK **
 TRANSACTION FILE ANALYZER

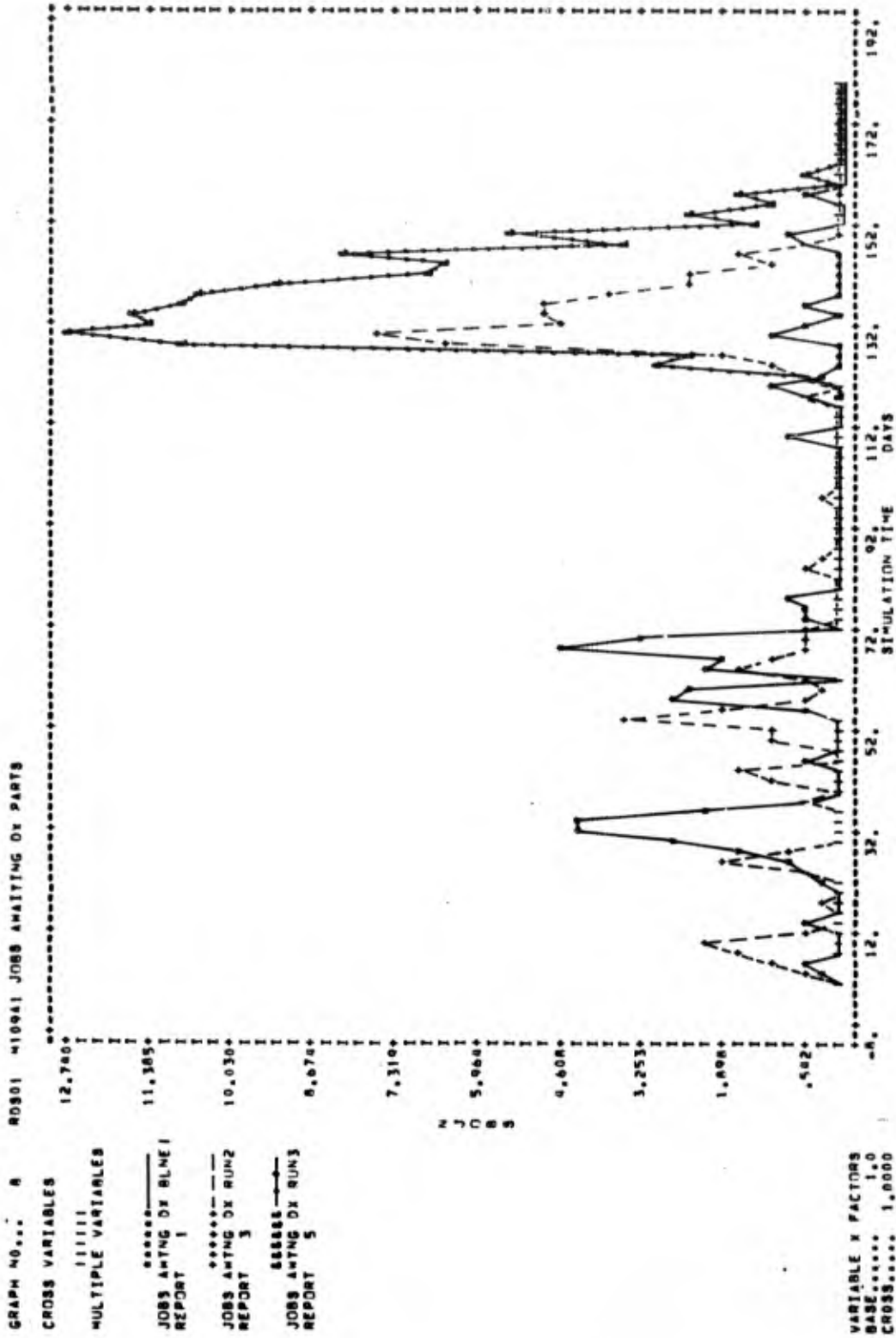

Figure III-22. M109A1 Jobs Awaiting DX Parts at RDS 01

ANALYSIS OF THE BDM CORP
 DATE: 1/ 7/ 1982
 RUN NAME: BLME/RUN 2/RUN 3

** MAWLOGS MODEL MACATK **
 TRANSACTION FILE ANALYZER

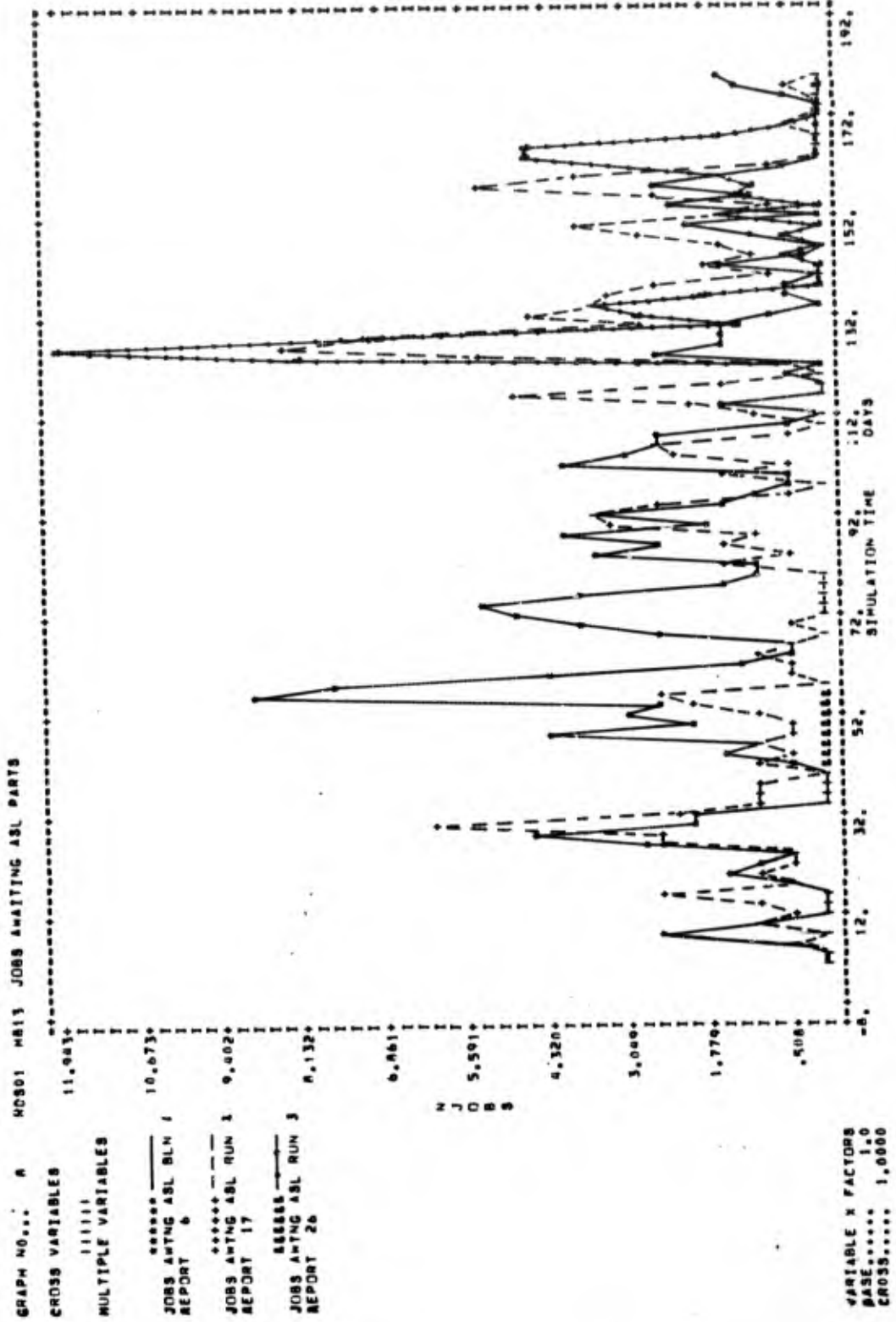

Figure III-23. M813 Jobs Awaiting ASL Parts at RDS 01

ANALYST, THE BDM CORP
 DATE, 1/ 7/ 1982
 RUN NAME, BLNE/RUN 2/RUN 3

** MACLOSS MODEL MACATAN **
 TRANSACTION FILE ANALYZER

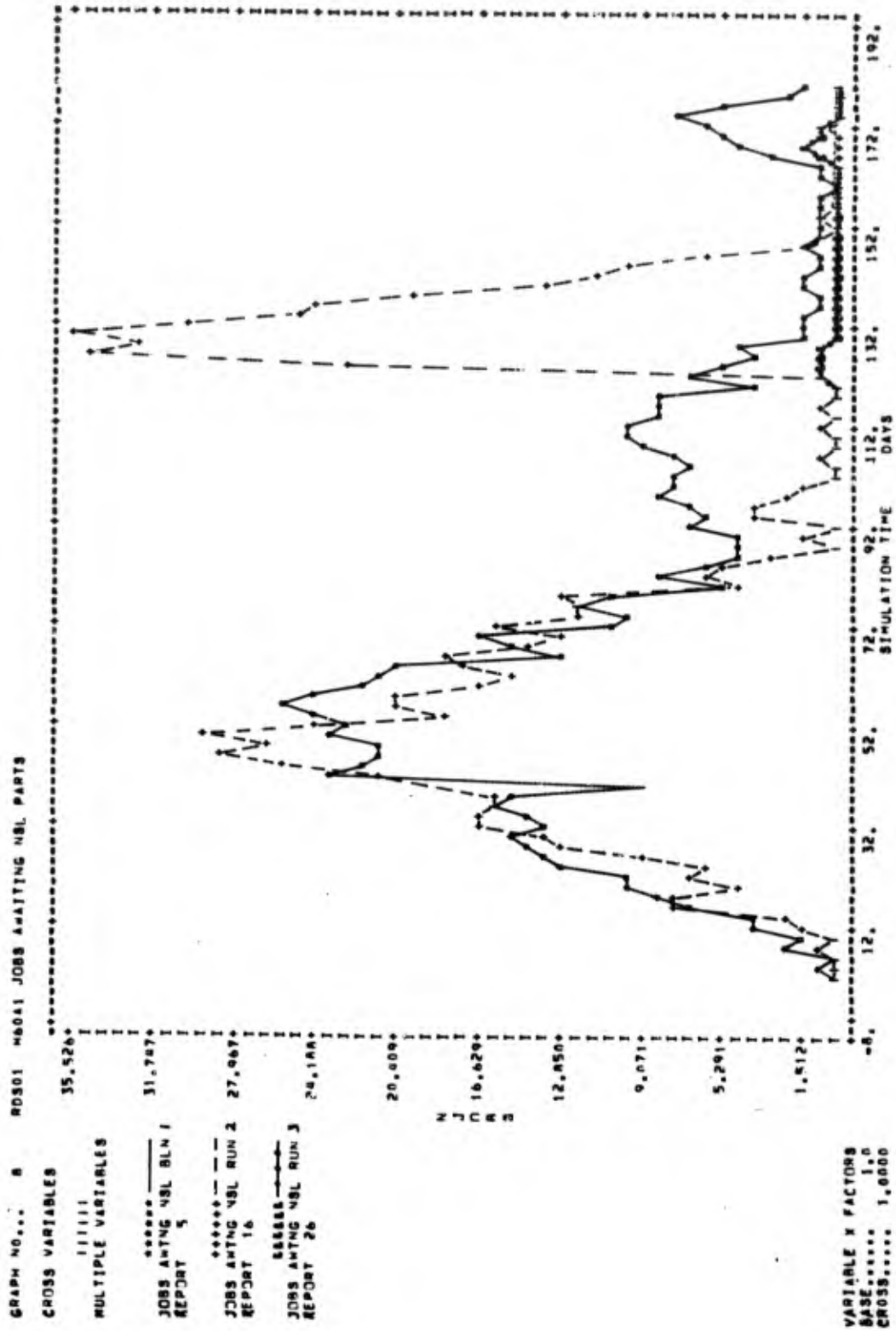

Figure III-24. M60A1 Jobs Awaiting NSL Parts at RDS 01

days used in this study, NSL is still a significant problem. OST, and delays in supply are discussed in Chapter VI.

4) Skills Utilization (D + 121 to D + 180)

The analysis of MEMO's impact on skills from D to D + 120 highlighted, by echelon, those MOSs with improved, i.e., lower, utilization. This section will quantify the impact the deferred work for those MOSs has when it is worked off in D + 121 to D + 180. The general result is that this accumulated backlog overwhelms the maintenance system, particularly at RDS and GS. This is true also in Run 3 when accumulated nonessential maintenance is ignored. So the apparent benefit of MEMO will be shown to be transitory and costly in terms of the surges in MOS requirements needed to work off the deferred maintenance on the vehicles.

a) Deferred Workload Impact on Skills at FDS
(D to D + 120)

FDS experiences only minimal increases in MOS requirements. The reason for this was pointed out in the MEMO period skills analysis: only the 63H and 63G experienced significant workload reductions in the MEMO period. The increases in requirements for these MOSs are shown in Figures III-25 and 26. The average number of 63H busy increases from its MEMO period average of 2.1 to 4.2 in Run 2. With nonessentials eliminated (in Run 3), the shifting of work forward increases the average number busy to 6.4, well below the 12 authorized. The 63G has a sustained surge to its authorization of 2 at FDS and is clearly overloaded in Run 2 and Run 3.

b) Deferred Workload Impact on Skills at RDS
(D + 121 to D + 180)

Surge requirements at RDS are more pronounced. The MOSs with large deferrable workloads as previously identified are shown in Table III-32. Figures III-27 and III-28 are typical of the large magnitude of requirements for these MOSs. Elimination of nonessential work in Run 3 helps but does not prevent noticeably higher utilization in the non-MEMO period.

ANALYST, THE BDM CORP
 DATE, 1/ 7/ 1982
 RUN NAME, BLNE/RUN 2/RUN 3

** MAPLOGS MODEL MACATK **
 TRANSACTION FILE ANALYZER

GRAPH NO... 2 FSDI NUM 63H BUSY

GROSS VARIABLES

 MULTIPLE VARIABLES

 SUM 63H BUSY MEMO 1
 REPORT 5

 SUM 63H BUSY MEMO 2
 REPORT 18

 SUM 63H BUSY MEMO 3
 REPORT 31

 SUM 63H BUSY MEMO 4
 REPORT 44

 SUM 63H BUSY MEMO 5
 REPORT 57

 SUM 63H BUSY MEMO 6
 REPORT 70

 SUM 63H BUSY MEMO 7
 REPORT 83

 SUM 63H BUSY MEMO 8
 REPORT 96

 SUM 63H BUSY MEMO 9
 REPORT 109

 SUM 63H BUSY MEMO 10
 REPORT 122

 SUM 63H BUSY MEMO 11
 REPORT 135

 SUM 63H BUSY MEMO 12
 REPORT 148

 SUM 63H BUSY MEMO 13
 REPORT 161

 SUM 63H BUSY MEMO 14
 REPORT 174

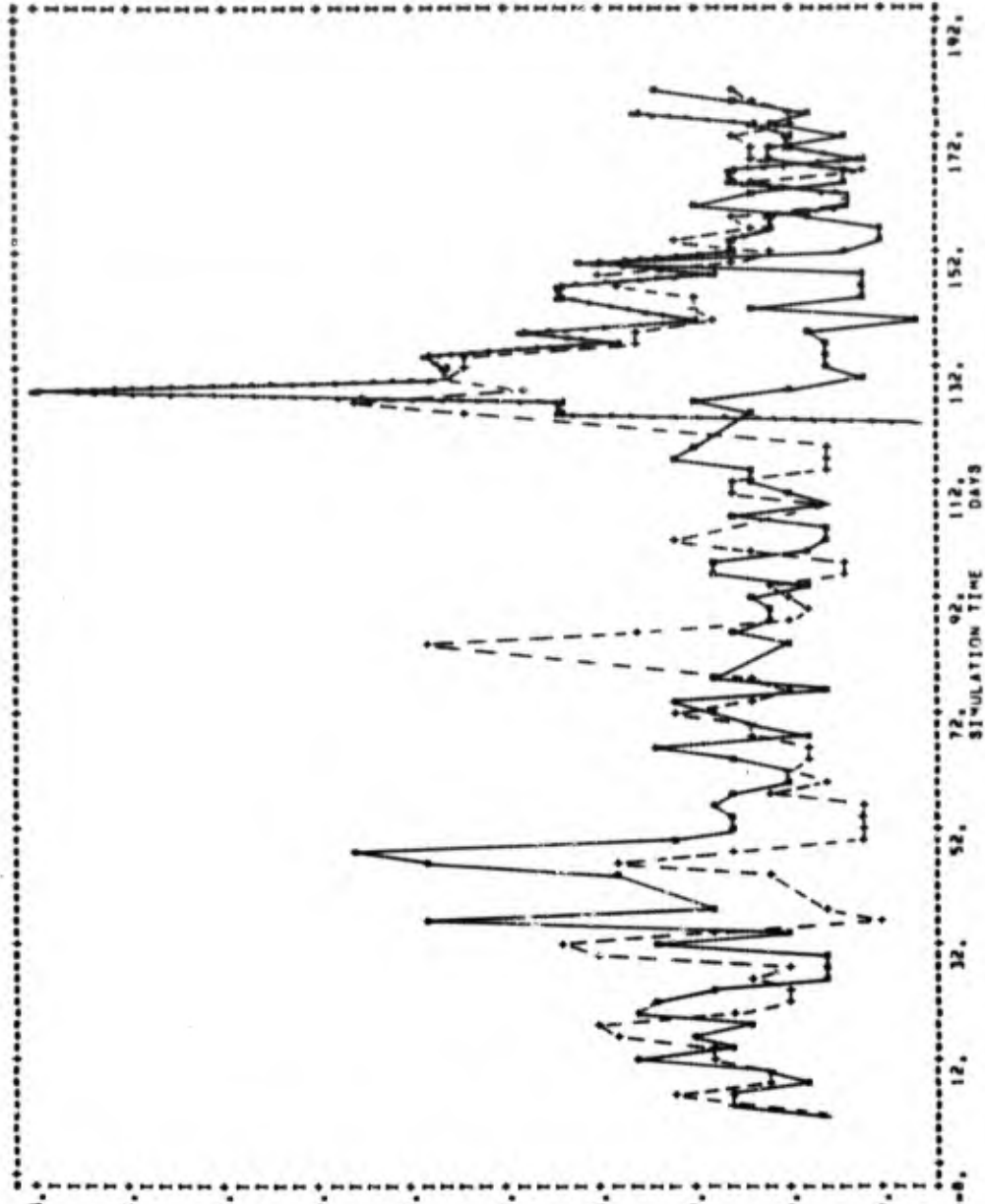

VARIABLE Y FACTORS
 USE..... *1E+01
 RISS..... *1E+03

Figure III-25. Number of 63H Busy at FDS 01

ANALYST: THE BDM CORP
 DATE: 1/17/1982
 RUN NAME: BLME/RUN 2/RUN 3

*** MAMLOGS MODEL MACATK ***
 TRANSACTION FILE ANALYZED

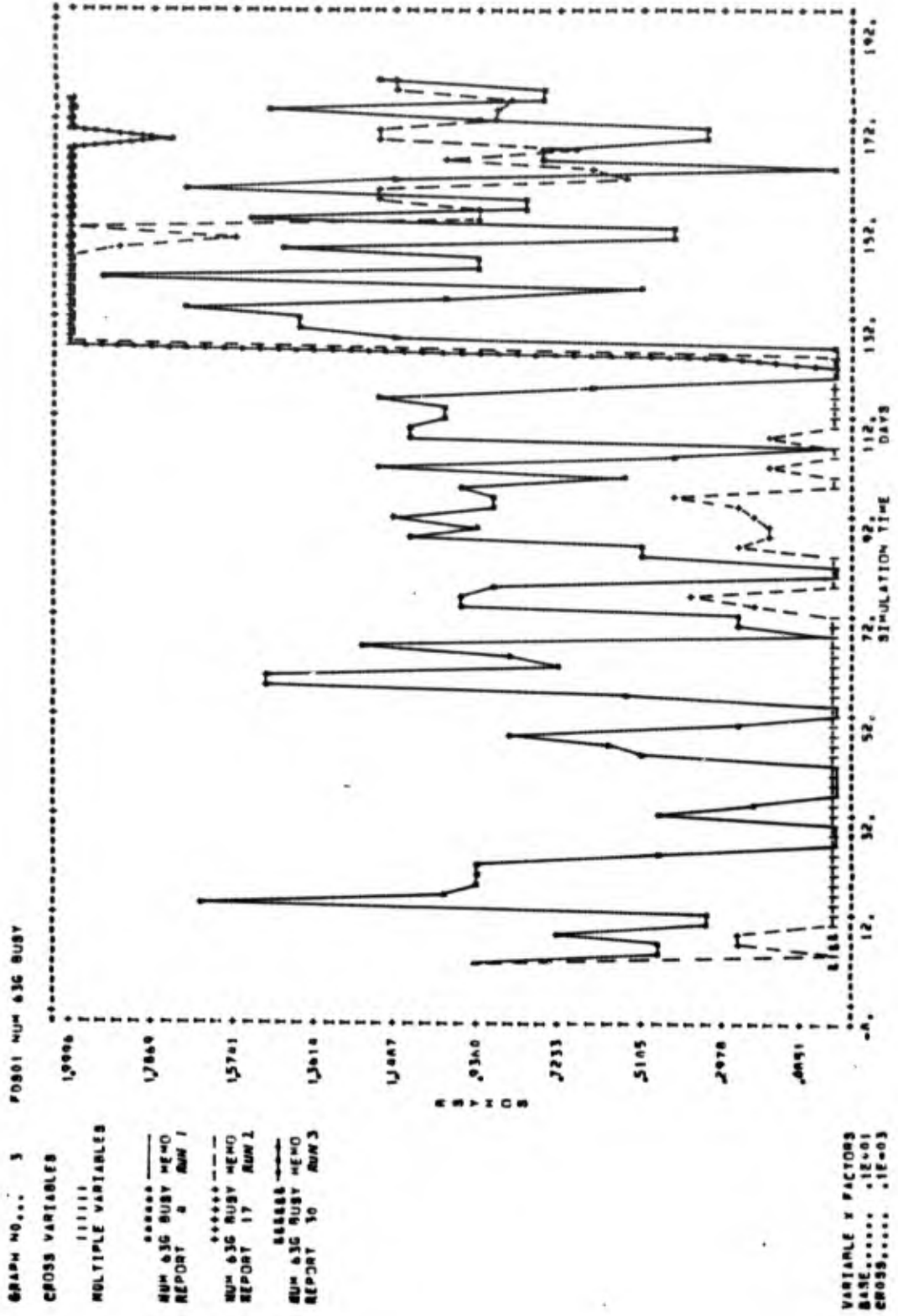

Figure III-26. Number of 63G Busy at FDS 01

ANALYST: THE BDM CORP
 DATE: 1/7/1982
 RUN NAME: BLNE/RUN 2/RUN 3

•• MAILLOG MODEL MACATK ••
 TRANSACTION FILE ANALYZER

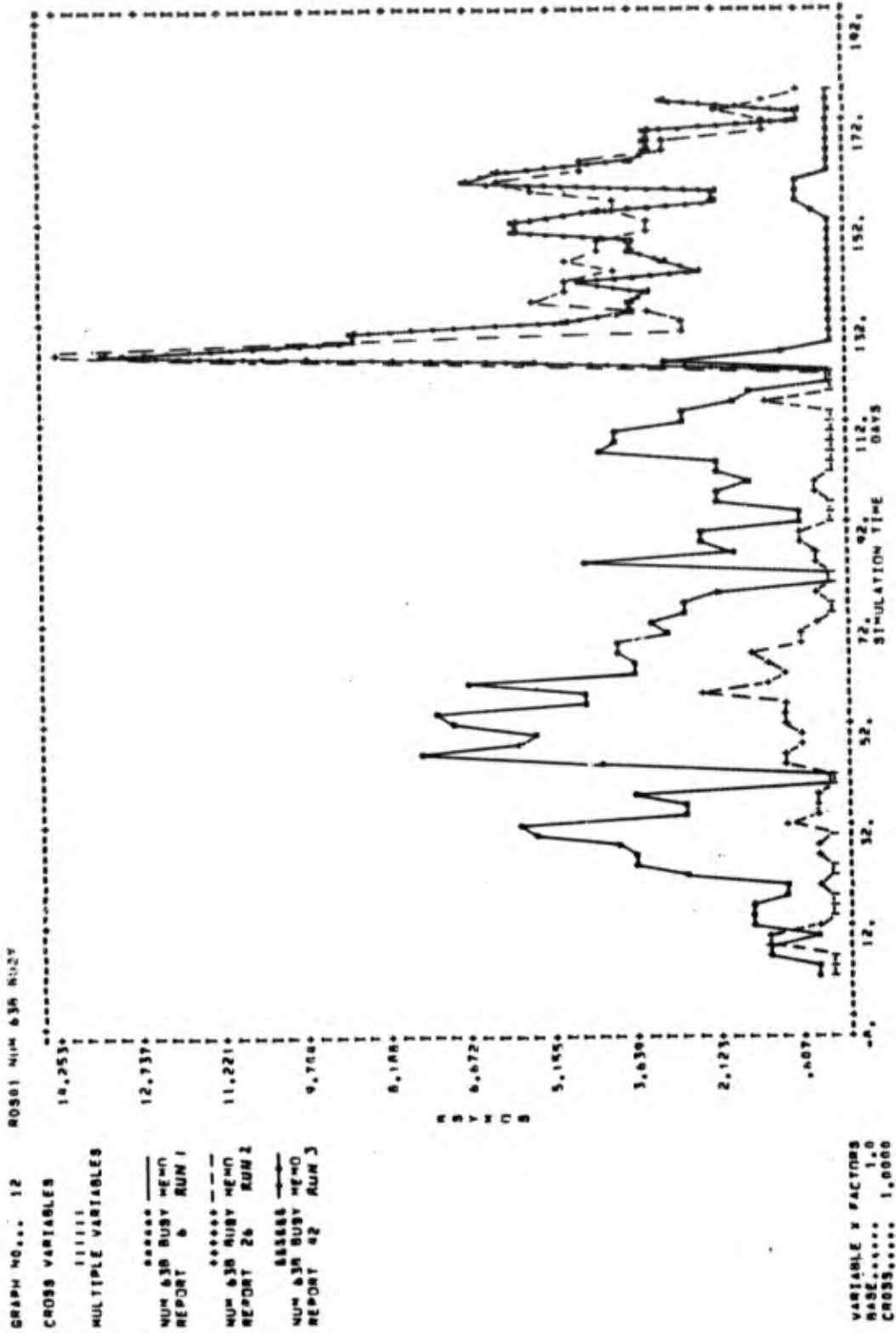

Figure III-27. Number of 63B Busy at RDS 01

ANALYST, THE BDM CORP
 DATE, 1/ 7/ 1982
 RUN NAME, BLNE/RUN 2/RUN 3

** HARLOGS MODEL MACATAK **
 TRANSACTION FILE ANALYZER

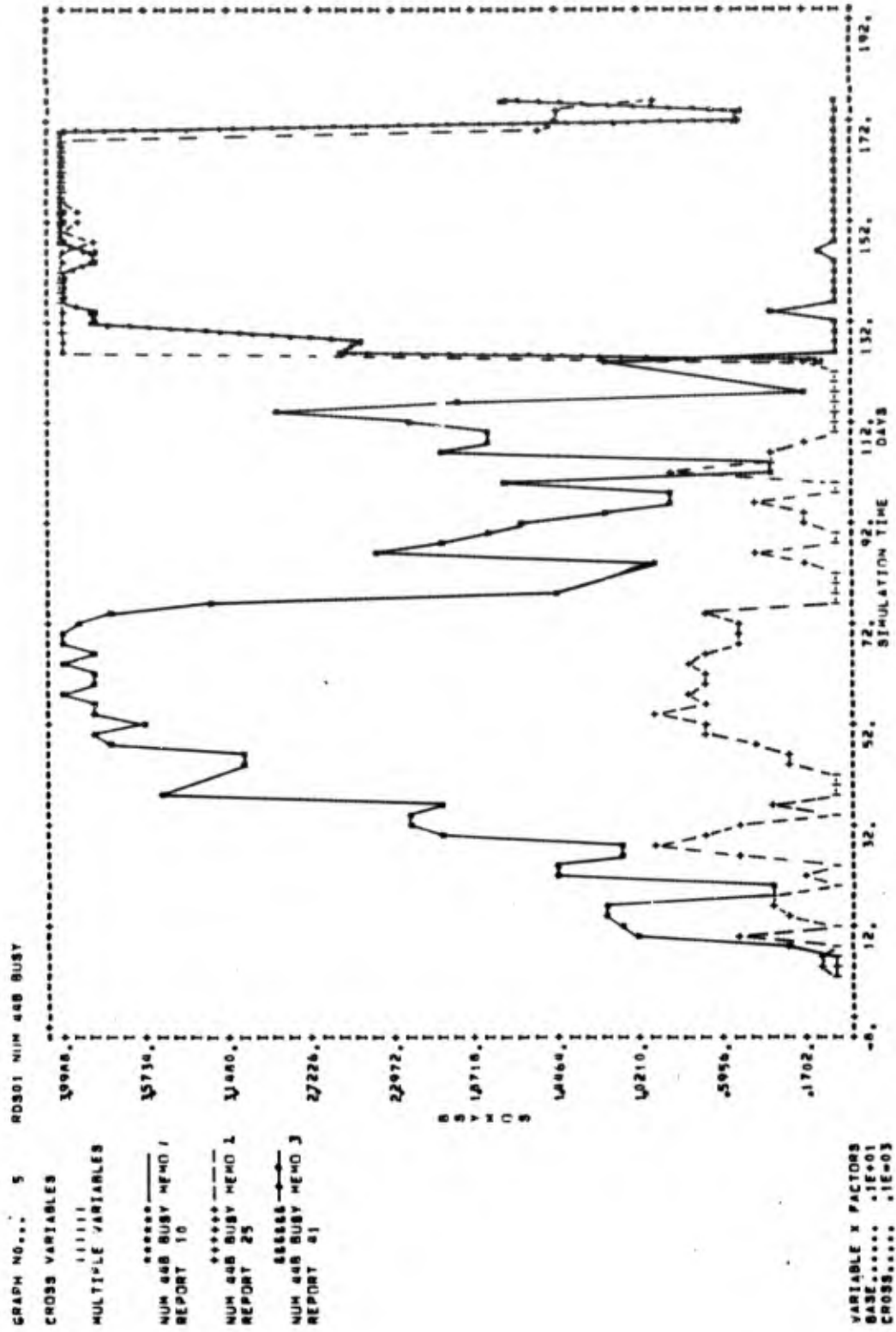

Figure III-28. Number of 44B Busy at RDS 01

TABLE III-32. MOSs AT RDs WITH LARGE WORK BACKLOGS
(D + 121 TO D + 180)

MOS	AUTHORIZATION	AVG BUSY (D TO D+120)		AVG BUSY (D+121 TO D+180)		MAX BUSY (D+121 TO D+180)	
		RUN 2	RUN 3	RUN 2	RUN 3	RUN 2	RUN 3
44B	4	.80		4.0	3.8	4.	4.
63B	15	1.2		8.2	6.2	15	13
63G	8	.93		1.1	1.7	8.	8.
63W	16	5.2		4.0	4.7	8	7
63Y	10	.57		2.6	1.2	10.	10.

c) Deferred Workload Impact on Skills at GS
(D + 121 to D + 180)

It was previously reported that the most savings in man-hours and in MOSs occurred at GS from D to D + 120. In the non-MEMO period from D + 121 to D + 180, those supposed savings completely overwhelm GS. This is dramatically demonstrated in Table III-33. Again, because skills were made available in unlimited quantity at GS in order to measure the skills requirements, the "MAX BUSY" column shows that requirement for the MOSs in the table. The table shows that the elimination of nonessentials in Run 3 greatly reduced requirements for the 44B, 45K, and 63Y. In Run 3, the 44B and 45K requirement was brought down under the TOE level.

TABLE III-33. MOSs AT GS WITH LARGE WORK BACKLOGS

MOS	TOE AUTH	AVG BUSY (D TO D+120)		MAX BUSY (D TO D+120)		AVG BUSY (D+121 TO D+180)		MAX BUSY	
		RUN 2	RUN 2	RUN 2	RUN 3	RUN 2	RUN 3	RUN 2	RUN 3
44B	8	.16		3	.80	LESS THAN	.1	36	3
45K	11	.83		7	1.7	LESS THAN	.1	56	7
63G	9	.30		3	1.1	1.5		44	49
63H	48	2.9		18	3.2	7.8		88	77
63Y	0	.09		3	.50	.05		39	10

The unlimited manpower available at GS allowed the backlog to be worked off at an incredible speed with very high skill requirements. Realistic limits on MOS availability would clearly prevent the bounce-back that the operational graphs show. Indeed, the operational availability would probably drop initially and continue downward.

D. CONCLUSIONS

1. General

The conclusions discussed at this point stem entirely from the Phase I "H" Series analyses. The conclusions focus on the validity of the MEMO concept applied continuously for 120 days and form the basis for development in Chapter IV of the contingency maintenance standard.

2. Validity of the MEMO Concept

Analyses of simulation results indicated that application of the MEMO concept can enable the maintenance system to operate more efficiently. The reductions in workloads that can be achieved under MEMO can enable the maintenance work force to increase the operational availability of end items over the levels attained under the current maintenance standard. The extent to which reductions in workloads and increases in operational availability can be increased are dependent upon the following factors.

a. Deferred Maintenance Actions and Their Frequency of Occurrence

The greatest increase in operational availability can be achieved when workloads are reduced on the end item itself at the organizational and forward direct support levels. The amount that the maintenance workload can be reduced is dependent upon the number of deferrable and nonessential maintenance actions that can be identified on the end item at those maintenance levels and more important, their frequency of occurrence. This was best observed in the results achieved when the MEMO concept was applied to the M-113A1 and the M-60A1. The largest reductions in maintenance workloads occurred at the organizational and forward direct support levels on the M-113A1. As a result, increases

in operational availability were realized. For the M-60A1 the largest reductions in workload occurred at the rear direct support and general support levels. Operational availability of the M-60A1 actually decreased in the simulation runs.

b. The Relationship of Management to MEMO

The MEMO concept must be applied in conjunction with good maintenance management. The application of the MEMO concept can result in an uneven reduction in maintenance workloads. For example, large reductions may be experienced at one level of maintenance but not at others. When this occurs the maintenance managers must intervene to redistribute the workload and insure that available maintenance resources are fully utilized. The simulation results for the M-60A1 and the M-813 are good examples of why maintenance management is critical. In both cases the application of the MEMO concept caused significant reductions of maintenance workloads at the rear levels and a forward migration of workloads to the organizational and particularly the forward direct support level. This resulted in significant decreases in operational availability for the tank and precluded any significant benefits from being achieved. However, by taking appropriate action, managers could have redistributed maintenance workloads from the organizational and particularly the forward direct support level to the rear. This would have put to use the maintenance resources available at the rear direct support and general support levels and relieved the forward levels of their backlogs. Those end items with excessive damages requiring unacceptable time to repair at one level should be evacuated to the next higher level, enabling forward resources to work on several as opposed to a single end item. This approach would have increased the operational availability of the M-60A1 and the M-813 in Run 2 above that of the baseline for D to D + 120.

c. Long-Term Application of MEMO

The simulation results indicated that a continuous application of the MEMO concept over an excessive period of time can create a deferred maintenance backlog that will overwhelm the maintenance system. Long-term deferment of maintenance actions can also lead to an increase in

the mission essential maintenance workloads as more complex failures stem from long-term deferment of relatively simple maintenance actions.

d. Proper Definition of MEMO

For the MEMO concept to be successful it must be uniformly applied through the use of published guidelines which properly define the concept. The guidelines used in the study were the 42 series FMs for the M-113A1, M-60A1, M-109A1 and the M-813. Although the MEMO concept was determined to be valid, serious questions arose concerning the validity of the 42 series FMS. The discrepancies noted in the FMs warrant separate discussion and are addressed in Chapter VII, Observations.

3. Benefits and Shortcomings of MEMO

a. Benefits of MEMO

The primary benefits of the MEMO concept are that it provides a means for more efficient use of available maintenance resources in critical items of equipment. This more efficient use of available resources in turn increases operational availability rates over those achieved under the current maintenance standard.

b. Shortcomings of MEMO

The shortcomings addressed at this point pertain specifically to the MEMO concept--not to the shortcomings of the 42 series FMs which are addressed in Chapter VII.

1) Skills

The application of the MEMO concept does not result in reductions of workloads for all skills. Furthermore the skills whose workload is reduced under the MEMO concept cannot always be used to assist or accomplish the work of other more heavily utilized skills, since the skills are not always transferable to new areas. This is also true to some extent for skill levels within a given MOS. As a result, shortages of critical MOSs cannot be relieved by MEMO in all cases.

2) End Items

As was observed in the simulation runs, not all end items react the same when MEMO is applied. This is due to the design of the equipment and its mission profile.

3) DX Items and Repair Parts

Continuous application of the MEMO concept over excessively long periods of time pose significant parts supply problems. If units requisition and accumulate parts required for deferred maintenance actions, the quantities will soon exceed the units' management and carrying capacities. If requisitions are submitted at the end of the MEMO period an unacceptable surge is placed on the supply system.

4) Failure Rates

Failure rates can be expected to increase as long-term deferment of relatively simple maintenance actions result in more complex failures. This can be avoided by incremental application of the MEMO concept.

4. Resource Expenditures

The results of the baseline and MEMO simulation runs were compared to determine whether any significant savings of manpower and other logistics resources were realized during MEMO application period. It was determined that reductions in workloads during MEMO would not constitute a savings. Resources conserved during the MEMO application period would be directed to performing mission essential maintenance and would be required at the end of the MEMO period when the deferred maintenance backlog was worked off. The only real savings would occur when nonessential maintenance actions were completely ignored. The savings would consist primarily of parts and time since manpower and other equipment resources (tools, test equipment and lift equipment) would be used on mission essential tasks. No attempt was made to quantify the cost savings attributable nonessential maintenance actions since the nonessential maintenance actions identified in the 42 series FMs are highly questionable.

a. Skills

Skills whose workload would be reduced under MEMO would be used to the extent possible to perform mission essential maintenance and to assist other MOSs that were in short supply. Furthermore, at the end of the MEMO period the skills whose workloads were reduced during MEMO would

be required to work off the deferred maintenance backlog. As a result no savings of skills can be attributed to the MEMO concept.

b. DX Items and Repair Parts

The parts required to accomplish deferred maintenance actions although not used during the MEMO application period would be used when the deferred maintenance backlog was worked off. Demands for parts over the MEMO and deferred maintenance work off period would most likely be greater than demands over the same period under the current maintenance standard. This increase occurs since the number of mission essential tasks performed during the MEMO period will most likely increase. This increase coupled with the parts required to perform deferred maintenance actions constitutes an overall increase in demands. Parts associated with deferred maintenance actions on equipment lost in combat could be viewed as a savings. This saving would most likely be offset by demands for parts required to perform the increased mission essential workload stemming from increased failure rates resulting from excessive long-term deferred maintenance.

c. Tools, Test Equipment and Lift Equipment

Tools, test equipment and lift equipment not used to perform deferred maintenance actions during the MEMO application period will be used to perform mission essential tasks. They will also be in great demand when deferred maintenance backlogs are worked off.

5. Incremental Application of MEMO

As observed in the simulation runs where the MEMO concept was applied continuously for 120 days, excessive deferred maintenance backlogs were created. It appeared that incremental application of MEMO would enable the benefits of MEMO to be realized without accumulating an unacceptable backlog. This was one of the basic premises used in constructing the contingency maintenance standard. The contingency maintenance standard is addressed in Chapter IV.

CHAPTER IV

CONTINGENCY MAINTENANCE STANDARD

A. INTRODUCTION

Based upon the results of the Phase I "H" series analyses a contingency maintenance standard was sought that would meet the following basic criteria:

- (1) Increase operational availability over the current maintenance standard when applying the same maintenance resources.
- (2) Preclude the accumulation of unacceptable deferred maintenance backlogs.
- (3) Preclude unmanageable surge requirements for skills and parts, and the accumulation of unmanageable quantities of parts required for deferred maintenance actions.
- (4) Minimize increased failure rates stemming from excessive long term deferment of maintenance actions that contribute to more complex failures.
- (5) Incorporate proven maintenance management techniques.
- (6) Take full advantage of modular equipment design incorporated in new and future equipment.

B. CONTINGENCY MAINTENANCE STANDARD OPTIONS

1. Options Considered

Five options were developed for consideration as the contingency maintenance standard. They are listed in Table IV-1 and discussed in subsequent paragraphs.

TABLE IV-1. CONTINGENCY MAINTENANCE STANDARD OPTIONS

<u>OPTION</u>	<u>DESCRIPTION/TITLE</u>
1	CURRENT MAINTENANCE STANDARD
2	42 SERIES FIELD MANUALS - MEMO STANDARD
3	INCREMENTAL MEMO APPLICATION STANDARD
4	INCREMENTAL MEMO AND MANAGEMENT APPLICATION STANDARD
5	SELECTED ITEM APPLICATION AND MANAGEMENT STANDARD

2. Option 1 (Current Maintenance Standard)

The current maintenance standard was considered an option if the advantages of MEMO or another contingency standards did not outweigh the retention of the current standard. The results of the simulation runs indicated that available maintenance resources could be used more efficiently under a deferred maintenance concept. Discussion with experienced maintenance personnel (commissioned officers, warrant officers, and non-commissioned officers assigned to the Ordnance School) also revealed that during combat operations, available maintenance resources would be used to effect only those repairs necessary to enable the equipment to accomplish its combat mission. Other maintenance actions would be deferred until the situation and availability of maintenance resources permitted their accomplishment. In other words, an informal MEMO system would exist in combat. The results of the simulation runs combined with these comments from experienced maintenance personnel indicated that retention of the current maintenance standard during combat was neither realistic nor desirable. The option to retain the current maintenance standard was therefore eliminated from further consideration.

3. Option 2 (42 Series Field Manuals (FM) MEMO Standard)

The adoption of the MEMO concept as portrayed in the 42 series FMs was considered an option if MEMO expectations were realized and improvements were deemed to be unnecessary. The results of the simulation runs indicated that the full potential of the MEMO concept, if applied for 120 days, could not be realized without substantial change. Analysis of

the 42 series FMs also indicated what appeared to be major discrepancies in the Contingency Maintenance Allocation Charts (CMACs) and in the methodology used to determine and assign essentiality codes.

For these reasons, Option 2 cannot be considered as a viable contingency maintenance standard.

4. Option 3 (Incremental MEMO Application Standard)

a. Description of Option 3

Option 3 consisted of an incremental application of the MEMO concept for varying periods of time during the transition period. The incremental approach applied the MEMO concept during preparation for offensive operations, during periods of attack and for short periods of time immediately following an attack. The continuous application period of MEMO was limited to between 15 and 20 days at the most. For example, during one portion of the simulation, MEMO was applied for a 5 day period preceding an offensive operation, 2 days during the operation and 5 days after the operation for a total of 12 days. During a defensive portion of the simulation MEMO was applied for 3 days during an enemy attack and 7 days following the attack for a total of 10 days. During the other portions of the simulation run deferred maintenance actions were worked off to the extent time and available resources permitted.

The objectives of this option were to take advantage of the benefits of MEMO without accumulating a deferred maintenance workload that would overwhelm the maintenance and supply systems. The period prior to attacks was viewed as a period in which available maintenance resources should be used most efficiently to increase the operational availability of equipment. During the attack, available maintenance resources were concentrated on those mission essential tasks required to return equipment to the battle. The period immediately following attacks was viewed as the period when available maintenance resources should be used to prepare for the next battle. Incremental application of MEMO and return to periods where deferred maintenance actions were accomplished enabled backlogs to be worked off without creating unacceptable or unmanageable surge requirements for parts and skills.

Under Option 3, management of workloads was limited to the application of the MEMO concept during the periods discussed. Since this option appeared to be able to meet all six selection criteria, the study team devoted a separate simulation run to it.

b. The Option 3 Simulation Approach

The study team determined that the number of variables introduced in the Option 3 simulation should be minimized. The primary objective was to measure the effects of applying the MEMO concept incrementally by direct comparison with Runs 2 and 3 of the "H" Series analyses. As a result, the Option 3 simulation was structured to include the same basic elements used in the "H" series analyses:

- (1) scenario
- (2) "H" series equipment
- (3) combat damage and attrition rates
- (4) mission essential maintenance actions as defined in the 42 series FMs.

The only new variable introduced in the Option 3 simulation run was the incremental application of the MEMO concept during the periods where activity was the most intense during the transition period. These periods were determined by analyzing the scenario used for the "H" series analyses. The application periods were varied in length to reflect the application of MEMO prior to offensive operations, during an attack and immediately after an attack. A recovery period was also designated at the end of the simulation run where deferred maintenance backlogs could be worked off. Figure IV-1 portrays the Option 3 simulation run, highlighting the periods where the MEMO concept was applied.

c. Results of the Option 3 Simulation

1) Operational Availability

Comparisons were made between the Option 3 simulation run and the original MEMO run (Run 2) at two points during the 120 day period. The first comparison was made at the end of 40 days covering the D to D + 40 period in which intensities were the highest. The second comparison was made at the end of the 120 day period. The results of these comparisons are shown in Table IV-2.

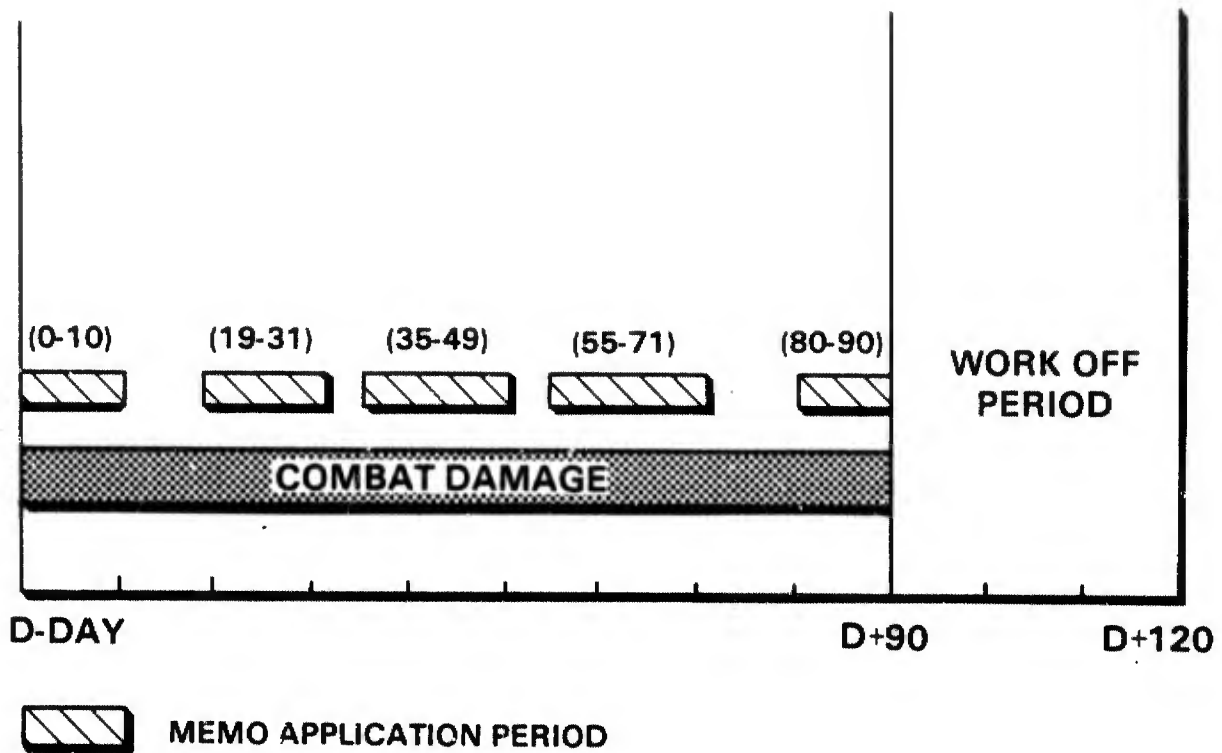

Figure IV-1. Option 3 Simulation Run

THE BDM CORPORATION

TABLE IV-2. AVERAGE OPERATIONAL AVAILABILITY
(OPTION 3 TO RUN 2)

<u>END ITEM</u>	AVG		AVG	
	D TO D + 40		D TO D + 120	
	<u>RUN 2</u>	<u>OP 3</u>	<u>RUN 2</u>	<u>OP 3</u>
M-60A1	49.4	49.6	49.6	52.0
M-813*	18.5/49.2	16.3/48.6	12.1/49.0	10.6/47.9
M-113	124.6	119	127.3	120.6
M-109	33.0	33.4	30.0	28.9

*AVERAGE OPERATIONAL AVAILABILITY FOR THE M-813 INCLUDES THE FLEETS
AT ORG 01 AND ORG 04 RESPECTIVELY.

THE BDM CORPORATION

During the D to D + 40 period the average operational availability for the M-60A1 and M-109A1 increased by 0.2 and 0.4 respectively while slight decreases of 5.6 occurred at ORG 01 for the M-113. This indicated that during the period of highest intensity, Option 3 was at least keeping pace with the continuous application of MEMO (Run 2). At the end of the 120 day period, average operational availability rates for Option 3 were slightly lower for all end items than in Run 2. The decreases were 2.4 for the M-60A1; 1.5 for the M-813 at ORG 01 and 1.1 at ORG 04; 6.7 for the M-113A1 and 1.1 for the M-109. Average maintenance turnaround times were also compared over the same periods to gain better insights as to how the maintenance system was performing and as to the deferred maintenance workloads being accumulated in Option 3. The statistics for Run 2 and Option 3 are provided in Table IV-3. Average turnaround times for reliability failures and combat damage do not vary significantly between Run 2 and Option 3. However, significant reductions of turnaround times relative to deferred maintenance were observed for each end item over the D to D + 40 and D to D + 120 periods in the Option 3 run. The most significant reduction occurred for the M-813 where deferred maintenance turnaround times were reduced from 37 days in run 2 to 2.4 days under Option 3 during the D to D + 40 period and from 37 to 4.1 overall. Reductions in deferred maintenance turnaround times in the Option 3 simulation averaged about 7 days for the M-60A1 and M-109A1 and about 4 days for the M-113A1.

This indicated that unacceptable deferred maintenance backlogs were not being accumulated in Option 3 and that surge requirements for parts and skills were being kept to manageable proportions. It also means that the end items are in better condition than in Run 2, since maintenance actions are not deferred for extended periods of time. As a result, more complex failures stemming from long deferral of maintenance are avoided. Further analysis revealed that at the end of the 120 day period no deferred maintenance backlogs existed under Option 3.

THE BDM CORPORATION

TABLE IV-3. AVERAGE TURNAROUND TIMES D TO D + 40 & D TO D + 120
(RUN 2 VS. OPTION 3 IN DAYS)

<u>END ITEMS</u>	<u>CATEGORY</u>	<u>D TO D+40</u>		<u>D TO D+120</u>	
		<u>RUN 2</u>	<u>OP 3</u>	<u>RUN 2</u>	<u>OP 3</u>
M60A1	RELIABILITY FAILURE	0.51	0.54	0.55	0.58
	COMBAT DAMAGE	6.2	5.8	7.4	7.3
	DEF MAINT	10.8	3.3	10.8	2.8
M813	RELIABILITY FAILURE	0.28	0.31	0.3	0.34
	COMBAT DAMAGE	2.9	3.4	3.6	3.7
	DEF MAINT	37	2.4	37	4.1
M113A1	RELIABILITY FAILURE	0.86	0.83	1.0	0.96
	COMBAT DAMAGE	5.5	5.8	5.7	6.0
	DEF MAINT	7.5	3.1	7.5	3.9
M109A1	RELIABILITY FAILURE	0.83	0.77	0.89	0.84
	COMBAT DAMAGE	5.0	4.9	5.4	5.4
	DEF MAINT	10.3	3.0	10.3	3.3

Since deferred maintenance actions were not accumulated in Option 3, but worked off in a more timely manner the condition of the equipment was significantly better than for Run 2. This decreased the likelihood of increases in failure rates and mission essential workloads stemming from long term deferment of maintenance actions. The success of the simulation results for Option 3 led to two other options which are refinements of Option 3. These two options were similar enough to Option 3 that they could be analyzed without simulation.

5. Option 4 (Incremental MEMO and Management Application Standard)

a. Description of Option 4

Option 4 was developed as a result of lessons learned during the "H" series analyses and the analysis of the Option 3 simulation results. Option 4 is basically the same as Option 3 except for two major modifications.

In Option 4 MEMO would be applied incrementally under the same conditions as in Option 3 (prior to offensive actions, during intense periods of combat (offensive and defensive) and immediately after an attack). However, deferred maintenance actions would be accomplished during periods of MEMO application if required resources and time were available. This would distribute deferred and mission essential maintenance workloads more evenly than in Option 3, make better use of available resources and assist in leveling out the peaks and valleys of maintenance activity.

Secondly, under Option 4 maintenance managers at each level would coordinate and regulate the distribution of maintenance workloads. For example, if the capacity was exceeded at one level, the maintenance manager would cause more extensively damaged equipment to be evacuated to the next higher level for repair. He would also arrange for additional backup support from the next higher level to assist in working off backlogs.

b. Advantages and Disadvantages of Option 4

Option 4 takes advantage of the benefits derived from the incremental application of the MEMO concept and incorporates proven maintenance management procedures. As a result the maintenance workloads can

be more evenly distributed to available maintenance resources than in Option 3. Additionally, the employment of proven maintenance management procedures enable the forward migration of workloads experienced in Run 2 of the "H" series analysis and in the Option 3 simulation run to be controlled or eliminated.

The combination of incremental application of the MEMO concept and proven maintenance management procedures will enable operational availability rates to be increased in Option 4 over those achieved in Option 3 and Run 2 in the "H" series analyses. At the same time, the deferred maintenance backlogs will be reduced over those experienced in Option 3.

The major limitations of Option 4 are that the emphasis of management focuses on each level as opposed to the total system and that MEMO is applied arbitrarily to all equipment. First of all, maintenance managers at one level cannot be permitted to route overflows to the next level if the higher level is as equally or more overburdened. Secondly, it may be desirable to focus most or all available maintenance resources on selected types of equipment to meet operational needs rather than the application of the MEMO concept to all equipment regardless of need.

6. Option 5 (Selected Item Application and Management Standard)

a. Description of Option 5

Option 5 resembles Option 4 in three respects. First, MEMO is applied incrementally with deferred maintenance actions accomplished during MEMO periods when resources and time are available. Second, when maintenance capacities are exceeded at their level, maintenance managers request backup support. Last, more heavily damaged equipment is repaired at higher levels. However, Option 5 differs from Option 4 in two areas. First the role of the maintenance manager is significantly increased in Option 5. Second, MEMO is applied only to selected types of equipment as determined by operational needs.

Option 5 incorporates management at each maintenance level with the total system manager. As in Option 4, the role of the manager at each level is to request backup support and arrange for the more heavily

THE BDM CORPORATION

damaged equipment to be repaired at higher levels when his maintenance capacities are exceeded. The role of the total system manager is to insure that maintenance resources available in the overall system are fully and most efficiently utilized.

Maintenance managers also must distinguish between the repair of end items (the M-60A1, M-1, M-813, M-2, M-3, etc.) and the repair of reparable for the end items. Deferrability of repairs on the end items is determined using the essentiality codes contained in annotated MACs in the TM for each end item. Essentiality for reparable on the other hand is determined by maintenance managers based upon availability and demand. For example, the repair of engines and transmissions can be deferred at the general support level if there are sufficient engines and transmissions available in supply to meet demands and the maintenance resources can be used to repair either end items or other reparable that are in short supply. In this respect essentiality coding of maintenance actions for reparable is determined by managers from day to day based upon operational requirements. It is not simply indicated in the CMAC or MAC on a one time basis.

Under Option 5, maintenance managers would also be called upon to apply the MEMO concept to selected types of equipment, for example the M-60A1, to meet operational requirements. Other types of equipment (M-813, M-113) might continue under the current maintenance standard or under a priority system which would enable all transferable MOSs to be shifted to the most critical items of equipment. In effect under Option 5, maintenance managers would be relied upon to use the MEMO concept as a tool to distribute workloads to available maintenance resources over space and time, and also focus available resources on those types of equipment most critical to operational needs. Higher level maintenance units can also form and deploy maintenance augmentation packages to lower levels--particularly the organizational and forward direct support level to increase the capabilities to repair major end items by replacing faulty components. These augmentation packages consist of maintenance personnel accompanied by tools, parts and DX items necessary to accomplish required repairs.

b. Advantages and Disadvantages of Option 5

Option 5 provides the total system approach that is most responsive to operational needs, both in terms of increasing the operational availability of the most critical end items and in terms of focusing maintenance resources on reparable items that are in short supply. The incorporation of total system management with management at each level insures the most even distribution of workloads and that all available resources are fully and efficiently utilized. This includes the capability to form and deploy maintenance augmentation packages consisting of personnel with tools and parts to forward maintenance levels.

The greatest potential problem area in Option 5 is the capability of the maintenance managers. For the managers to be able to accomplish their roles, additional training will most likely be required in all related areas. In addition, an effective means of exchanging maintenance management information will be required.

c. COMPARISON OF OPTIONS

1. Option 1 (Current Maintenance Standard)

No further consideration was given to Option 1 as a contingency maintenance standard when the results of the "H" series analyses indicated that equipment operational availability could be increased employing the same quantities of resources under the MEMO concept.

2. Option 2 (42 Series FM - MEMO Standard)

Two factors precluded further consideration being given to Option 2 as a contingency maintenance standard. First, long-term continuous application of the MEMO concept generated a deferred maintenance backlog that overwhelmed the maintenance and supply systems. Second, the results of the "H" series analyses indicated that attempts to apply the MEMO concept without proper application of proven maintenance management techniques could result in degradations of equipment operational availability rates. The most extreme example observed in the analysis was the forward migration of maintenance workloads on the M-60A1 which could have been precluded by proper maintenance management.

3. Option 3 (Incremental MEMO Application Standard)

The incremental application of the MEMO concept in Option 3 produced operational availability rates comparable to those in Option 2 without accumulating a deferred maintenance backlog. Like Option 2, the absence of maintenance management precluded MEMO expectations from being fully realized. While Option 3 was determined to be more advantageous than Options 1 or 2, it did not approach the benefits that could be realized under Options 4 and 5, both of which employ the MEMO concept in conjunction with maintenance management.

4. Option 4 (Incremental MEMO and Management Application Standard)

Option 4 improves upon Option 3 by applying rudimentary maintenance management in conjunction with incremental application of the MEMO concept. In Option 4 maintenance management focuses on two areas. First, during periods of MEMO application, deferred maintenance is accomplished when resources and time are available, thus further decreasing deferred maintenance impacts. Second, when the maintenance workload exceeds the capacity of the maintenance organization at a given level, either in terms of total workload or time and resources required to return a single end item to service, the maintenance manager at that level will attempt to arrange for backup support from the next higher level. This approach helps to insure that the maintenance resources at each level are fully utilized and provides for more even distribution of workloads from one level to another. It also enables the forward migration of workloads such as those experienced for the M-60A1 to be precluded. While Option 4 enables the potentials of the MEMO concept to be realized to a greater extent than Options 1, 2 or 3, it does not take into account the management problem associated with evenly distributing workloads over the total maintenance system or the need to concentrate available maintenance resources on specific types of equipment such as the tank. In this respect, Option 4 does not approach the potential that can be realized under Option 5.

5. Option 5 (Selected Item Application and Management Standard)

Compared to the other options, Option 5 provides the greatest potential for realizing MEMO benefits and the greatest flexibility for

meeting operational needs. Like Option 4, the MEMO concept is applied incrementally. Deferred maintenance actions are also worked off during periods of MEMO applications when resources and time are available.

Option 5 offers major advantages over the other options in three areas. First maintenance management is oriented more towards the total system. Where Option 4 was concerned with capacities and backup support at each individual level, Option 5 requires another level of management to insure that workloads that exceed the capacity at one level are not arbitrarily moved to another level where overloads are even greater. Second, Option 5 recognizes that some equipment may be more critical to operational needs than others. Therefore, the MEMO concept can be applied to selected types of equipment in Option 5 as opposed to all equipment in the other options. Last, Option 5 differentiates between maintenance actions on the end item and those on reparable, providing a more realistic and workable approach to essentiality coding. Management of the repair of reparable will become an increasingly important factor as modular design increases in new equipment.

D. SELECTION OF THE RECOMMENDED CONTINGENCY MAINTENANCE STANDARD

1. Summary of Comparisons

The matrix in Table IV-4 summarizes the manner in which each of the five options meet the basic criteria put forth in paragraph A.

2. Recommended Contingency Maintenance Standard

Based upon the analyses and comparisons of the Options, Option 5 is recommended as the Contingency Maintenance Standard. This is the option that is most responsive to operational needs, both in terms of increasing the operational availability of the most critical end items and in terms of focusing maintenance resources on reparable that are in short supply.

TABLE IV-4. SUMMARY OF OPTIONS

CRITERIA	OPTIONS				
	1	2	3	4	5
1. INCREASES OPERATIONAL AVAILABILITY OVER CURRENT STANDARD	N/A	YES	YES	YES	YES
2. PRECLUDES UNACCEPTABLE DEFERRED MAINT. BACKLOGS	YES	NO	YES	YES	YES
3. PRECLUDES UNMANAGEABLE SURGE REQUIREMENTS FOR SKILLS AND PARTS	YES	NO	YES	YES	YES
4. PRECLUDES UNMANAGEABLE ACCUMULATION OF PARTS FOR DEFERRED MAINT. ACTIONS	YES	NO	YES	YES	YES
5. MINIMIZES INCREASED FAILURE RATES STEMMING FROM DEFERRING MAINT.	YES	NO	YES	YES	YES
6. INCORPORATES PROVEN MANAGEMENT TECHNIQUES					
a. AT EACH LEVEL	NO	NO	PARTIAL	YES	YES
b. FOR TOTAL SYSTEM	PARTIAL	NO	NO	NO	YES
7. CONSIDERS REPAIR OF END ITEMS AND REPAIR OF REPARABLES	NO	NO	NO	NO	YES

CHAPTER V
1986 ERA EQUIPMENT ANALYSES (PHASE II)

A. INTRODUCTION

1. General

The Phase II effort evaluated the validity of applying the contingency maintenance standard to 1986 era equipment during the transition to war period. The 1986 era equipment included in the evaluation were the M-1 "Abrams tank, the M-2 "Bradley" Infantry Fighting Vehicle (IFV), the M-3 Cavalry Fighting Vehicle (CFV), the M-901 Improved TOW Vehicle (ITV), and the XM-987 Multiple Launch Rocket System (MLRS).

Although the use of simulation modeling to accomplish Phase II was contemplated, the study team in concert with the Army Study Advisory Group determined that modeling 1986 era equipment would be neither necessary nor prudent. First of all, the lessons learned during the Phase I effort and the applicability of Phase I findings to the 1986 era equipment indicated that the Phase II effort could be accomplished satisfactorily without the use of simulation modeling. Secondly, the point to which some of the 1986 era equipment had progressed in the new equipment development and test cycles precluded the availability of some data. Other data had not yet been validated. The results of any simulation based upon incomplete data and data that had not been validated would be highly questionable and could cast doubt on the validity of the entire effort. It is felt that the methodology utilized in this study should be applied to the future equipment when valid data becomes available.

In spite of the tentative nature of Phase II data, it was still possible to judge the applicability of the MEMO contingency standard to 1986 era equipment. It is believed that the MEMO standard will be a valid concept for Phase II items provided that good management is a part of its application.

Furthermore, analysis of the data available on Phase II end items revealed significant differences in 1986 era equipment that may change the

THE BDM CORPORATION

mission profile of organizational and direct support maintenance and may aggravate known problems in the maintenance system.

B. 1986 ERA EQUIPMENT DATA AVAILABILITY

1. General

Not all 1986 era equipment has reached the state in the new equipment development and test cycle where all information concerning their maintainability or their maintenance requirements has been completed. Each 1986 era end item to be considered during the Phase II analyses is discussed below to highlight these areas in which data is either incomplete or requires validation.

2. M-1 Tank

Logistics Support Analysis Reports (LSAR) for the M-1 tank were provided to the study team by the project manager's office. Since the LSARs were based primarily on engineering estimates and had not been updated to include test data, the validity of the LSARs in their present state was questioned by the Army. After discussion with the project manager's office, representatives of Army agencies and the Study Advisory Group, it was determined that no attempt should be made to use the current LSAR data for simulation modeling. As a result, no effort was made to determine essentiality codes for the maintenance actions in the LSAR 04, Maintenance Allocation Summary.

3. M-2/M-3 (IFV/CFV)

LSARs were provided for the M-2 and M-3. Army representatives did not question the validity of the M-2/M-3 data.

A working conference was held at Aberdeen by the Ordnance School to determine essentiality codes for all maintenance actions for the M-2 and M-3, and to discuss the shotline data that had been provided by the Army Material Systems Analysis Activity (AMSAA). While essentiality codes were assigned to each maintenance action indicated in the Maintenance Allocation Summary (LSAR 04), the lack of a disciplined methodological approach makes the validity of the codes suspect. The methodology used consisted of Army

maintenance experts reaching a consensus as to the essentiality and deferability of each maintenance action. In the absence of a disciplined approach, many of the same inconsistencies contained in the 42 series FMs also occurred in the data developed for the M-2 and M-3.

Shotline data for the M-2 and M-3 had been provided to the BDM study team by AMSAA. This data had been developed to support a previous study effort aimed at identifying combat PLL requirements. A review of the shotline data indicated some discrepancies between the maintenance actions listed in the shotlines and those contained in the Maintenance Allocation Chart Summary. Further analysis indicated that the shotlines had actually been developed for the MICV (XM-701), an earlier version similar to but not the same as the M-2/M-3 (IFV/CFV).

4. M-901 ITV

Detailed maintenance data for the M-113A1 chassis of the M-901 was available and had been used in the "H" series analyses. The same was true for the M-113A1 shotline data. However, neither the LSAR nor shotline data were available for the TOW portion of the M-901 until late in the study effort.

The fact that the majority of the maintenance for the M-901 was related to the M-113A1 chassis and that the M-113A1 had been simulated in the "H" series analysis, to include the simulation of the Option 3 contingency standard, enabled some conclusions to be drawn as to the applicability of the contingency standard to 1986 era equipment. However, the non-availability of detailed maintenance data and shotlines for the TOW portion of the M-901 precluded simulation modeling.

5. XM-987 MLRS

LSAR data was obtained for the MLRS and appeared to be acceptable to the Army. However, no shotline data had yet been developed. Due to the lack of shotline data required to simulate the item, no actions were taken to determine essentiality codes for maintenance actions. The lack of shotline data and essentiality codes was a deterrent to simulation modeling.

C. APPLICABILITY OF PHASE I FINDINGS

1. General

The 1986 era equipment and the maintenance structure that will support it were analyzed to determine the extent to which the contingency maintenance standard could be applied to the 1986 era equipment.

2. 1986 Maintenance Structure

The analysis of the 1986 maintenance structure focused on the Army 86 efforts. A review was made of the Division 86 and Corps 86 Unit Reference Sheets (URSs) and draft TOEs obtained from the Logistics Center and which are on file at The BDM Corporation. It was determined that even though alterations had been made in the maintenance organizations, the levels of maintenance and the maintenance functions to be accomplished at each level remained consistent with those of the "H" series system.

The levels of maintenance in the "H" series and "1986" systems consist of organizational, forward direct support, rear direct support and general support maintenance. The functions are also basically the same, with the majority of repairs on the end items being accomplished at the organizational and forward direct support levels, and the majority of the repair of reparable accomplished at the general support and rear direct support levels.

The MOSs for the "H" series and 1986 series TOEs are also basically the same, although more system peculiar MOSs do appear in the 1986 TOEs. For example, the new MOSs for the M-1 tank and the M-2/M-3 are added to the 1986 TOEs.

3. Equipment Similarities.

The 1986 equipment is not unlike the "H" series equipment. This is particularly true for the M-901 which is essentially an M113A1 with a TOW fire control and launch package mounted on it.

Probably the two greatest differences between "H" series and 1986 era equipment are that the newer equipment is more sophisticated and has incorporated more modular design characteristics. While the incorporation of modular design does not affect the applicability of the contingency

maintenance standard per se, it may have significant impact on the structure and function of the maintenance system, particularly at the direct and general support levels. These areas are discussed in paragraph D.

4. Deferred Maintenance Profiles

During the "H" series analyses, the types of equipment which responded most favorably to the MEMO concept consisted of that equipment which had the highest occurrence of deferred maintenance actions (includes deferrable and non-essentials) at the organizational and forward direct support levels during the periods when MEMO was applied. Since the essentiality coding of maintenance actions for the 1986 era equipment has not been satisfactorily accomplished, profiles could not be constructed except for a partial profile for the M-901. As previously stated, the M-901 is based on the M-113A1 chassis. The M-113A1 had the profile most responsive to the MEMO concept during the "H" series analyses.

Although profiles could not be constructed for the other 1986 era equipment, the results of the working conference held at Aberdeen by the Ordnance School indicated that deferrable maintenance actions at the organizational and forward direct support levels could be identified on 1986 era equipment as they had been identified on their "H" series counterparts. This finding combined with the experience with the M-113A1 chassis in the Phase I analyses further substantiated that the contingency maintenance standard developed as a result of the Phase I analyses was applicable to 1986 era equipment.

5. Applicability of Phase I Findings

Once the 1986 era equipment and maintenance support structure had been analyzed, the findings of the Phase I study effort were reviewed for applicability to the 1986 era equipment. The following findings, upon which the contingency maintenance standard was based, were found to be applicable to 1986 era equipment.

- (1) When the MEMO concept is applied properly, some increase in operational availability can be expected. However, various types of equipment will react differently due to their design and mission profiles.

THE BDM CORPORATION

- (2) The application of the MEMO concept will not result in a uniform reduction in workloads for all MOSs. Some MOSs will experience significant reductions while others will experience little, if any.
- (3) Continuous deferment of maintenance actions over extended periods of time, for example, the 120 day period in the MEMO run (Run 2), will result in the accumulation of unacceptable deferred maintenance workloads. This will also result in unmanageable surge requirements for DX items, repair parts, skills and maintenance related equipment when attempts are made to work off the backlogs.
- (4) Continuous deferment of maintenance actions over extended periods of time will cause increased failure rates as more serious failures stem from long term deferment of relatively simple maintenance actions.
- (5) The application of a deferred maintenance standard must include sound maintenance management practices for the potential benefits to be fully realized.
- (6) The reduction in workloads attributable to deferred maintenance does not constitute a real savings in maintenance resources since:
 - (a) Time and resources that would have been used to accomplish deferred maintenance actions are used to accomplish mission essential maintenance.
 - (b) The maintenance resources not used to accomplish deferred maintenance actions at one point in time will be required to work off the deferred maintenance backlog.

D. IMPACTS OF MODULAR DESIGN

1. General

While modular design does not directly affect the application of the contingency maintenance standard to 1986 era equipment, modularization

may require changes to the structure and function of maintenance units. These changes stem from the increasing number of reparable required at the organizational and forward direct support levels to repair and return end items to service. The impacts of these increased requirements are discussed in this chapter to clarify this relationship to the implementation of the contingency maintenance standard.

2. Repair by Replacement

The modular design concept supports the repair of end items by replacement of faulty components that are easily removable. This enables the repair and return of end items to be accomplished at the organizational and forward direct support levels and reduces the requirement to evacuate equipment to higher levels for repair. This in turn decreases maintenance downtimes and enables the repair and return of equipment to the operational fleet to be accomplished more efficiently. While there is some modularization in the "H" series equipment, the full impact of modularization will not be felt until newer equipment in which modularization has been incorporated on a larger scale is fielded. The M-1 tank, M-2 IFV, M-3 CFV, XM-987 MLRS, and the TOW fire control and launch package of the M-901 ITV all stress modularization and repair by replacement of faulty components to a greater extent than in the M-60A1 tank, M-109 howitzer and M-113A1 APC.

3. Impacts of Modularization on the Maintenance System

The impacts of modularization can be observed by addressing two major aspects of the maintenance system; the repair of the end items and the repair of reparable components. Under the current maintenance system, maintenance resources at the organizational level focus almost entirely on the repair of the end item. At the forward direct support level the main effort is the repair of the end item, with a limited component repair capability. At the rear direct support and general support levels, the capability to repair components increases dramatically. As newer equipment is fielded, the problems associated with the supply of reparable and the repair of reparable will increase dramatically.

Significant increases in the breadth and depth of reparable required to support end item repair can be expected. Correspondingly, the

THE BDM CORPORATION

requirement for a component repair capability will increase. These increases will aggravate problems already being experienced by the maintenance system. The mobility and management of repair parts and components will become a much larger problem for maintenance units at all levels, particularly at the direct support level. Shortages of test, measurement, and diagnostic equipment (TMDE) and related software will be exacerbated. The need for facilities which permit the repair of sophisticated components will increase. The need for highly skilled component repairmen will increase, adding to the training and retention problems of the Army.

4. Changes to Structure and Functions

As more modularized equipment is fielded and the requirements for stockage, TMDE, component repair facilities and highly skilled manpower increase, the question becomes where to put them. One approach would be to leave the current maintenance structure and functions unchanged. This would mean adding stockage management capabilities, TMDE, facilities and highly skilled MOSs to the current maintenance units. This would result in significant increases in manpower and equipment for the forward direct support and rear direct support maintenance units of the division and an expanded component repair capability at the general support level in the Corps.

The practicality of maintaining an increased component repair capability in the division is questionable. The manpower and equipment increases associated with component repair will substantially increase the problems associated with moving the units of the division maintenance battalion, to include the forward direct support companies. It is already questionable as to whether or not these units can meet current mobility requirements. Secondly, the frequency with which these units will be required to move on the modern battlefield raises serious doubts as to the productivity of component repair facilities and MOSs even if centralized in the division rear area.

Another approach might be to change the structure and function of the maintenance units in the division. For example, the function of forward direct support companies might be changed to focus on increased DX

supply and repair of end items by augmenting organizational maintenance units when required. Maintenance support from the forward direct support companies might consist of backup organizational support and performance of those direct support maintenance actions that can be accomplished in the user battalion area. The stockage of reparable at the forward direct support level might be increased significantly to meet the needs of augmentation teams and the organizational maintenance elements. Component repair at the forward direct support level might be eliminated or at least restricted to testing evacuated reparable to insure that they are faulty prior to evacuation.

Another approach might be to centralize component repair at the general support maintenance level and focus divisional direct support units on increasing their DX supply role and repairing end items by replacement of easily removable components. In this respect, divisional DSUs would perform backup organization maintenance overflows and provide on-site augmentation in the form of skills, equipment, TMDE and repair parts and reparable to organizational maintenance elements. Very limited component repair could be accomplished at the division rear. This would consist of repair of selected components by replacement of easily removable components.

This approach replaces the direct support component repair capability by increasing stockage levels at the forward direct support and rear direct support levels. It also centralizes the highly skilled MOSs at component repair facilities further to the rear where the requirement to move is substantially reduced. Subsequently, the highly skilled MOSs can be used more productively. Capability to repair the end items forward would also be increased as direct support maintenance augmentation packages complete with skills, equipment and parts can be deployed to where they are most needed to actually repair end items as opposed to limiting work to diagnosis.

5. Areas for Further Analyses

The scope of the MEMO study, time and fiscal constraints precluded further analyses and development of total support concepts.

However, additional analyses appear to be required in this area to bring together the many related studies currently being conducted in the maintenance area and to more completely assess the impacts of increased component repair requirements related to emerging equipment.

E. CONCLUSIONS AND RECOMMENDATIONS

1. Applicability of the Contingency Maintenance Standard to 1986 Era Equipment

Analyses indicated that the contingency maintenance standard is applicable to the 1986 era equipment. The equipment design and mission profiles will permit deferred maintenance in the same manner as the "H" series equipment. Like the "H" series equipment, not all types of end items can be expected to react in the same manner to a deferred maintenance concept nor will uniform reductions in workloads be experienced for all MOSs. Additionally, reductions in workloads and resource expenditures during periods of deferred maintenance will be offset as deferred maintenance actions are worked off.

2. Changes of Maintenance Structure and Functions

Regardless of the maintenance standard, the impacts of modularization may require changes in the maintenance structure and function of the maintenance units. These changes are attributable to the increasing number of reparables associated with each of the newer end items and the increasing complexities of component repair. Additional analyses are recommended in this area to explore trade-offs associated with new approaches to component repair and stockage.

CHAPTER VI
PHASE III TASKS

A. INTRODUCTION

This chapter addresses the results of the Phase III analysis. It includes Task III.1 - Determine and define the impact of the contingency maintenance standard on the policies, procedures and doctrine contained in AR 750-1; Task III.2 - Determine how to interface the contingency maintenance standard with present maintenance methods; Task III.3 - Determine the impact of adopting the contingency maintenance standard in other theaters and areas of operation; and Task III.4 - Assess the impact of the contingency maintenance standard on the logistics system. Each task (Tasks III.1, III.2, III.3 and III.4) is discussed individually in subsequent paragraphs. Task III.5 which outlines the requirements for the study report does not require discussion.

B. CONTINGENCY MAINTENANCE STANDARD IMPACTS ON AR 750-1

1. General

The recommended contingency maintenance standard requires that AR 750-1 be changed in two areas. First, recognition of the contingency maintenance standard as an approved maintenance procedure is required at appropriate points throughout the AR. Second, a chapter which defines the contingency maintenance standard and its implementation should be added.

More extensive changes to AR 750-1 may be required as the full impacts of modularly designed equipment such as the M-1 tank, M-2/3 IFV/CFV, and MLRS are experienced. This is particularly true if decisions are made to change the functions of direct and general support maintenance by centralizing component repair at the general support level and replacing component repair with increased DX inventories at the direct support level.

2. Recognition of the Contingency Maintenance Standard (CMS)

Examples are given below of the type changes necessary in AR 750-1 to recognize the contingency maintenance standard as an approved maintenance procedure. The examples listed below are not intended to be all inclusive. The actual change document should be developed based upon a more thorough review of AR 750-1.

- (1) Paragraph 1-3b should include a brief paragraph that recognizes the contingency maintenance standard and provides general guidance as to when it should be applied. The paragraph should be similar in nature and content to paragraph 1-3b (2) which addresses the forward support concept.
- (2) Paragraph 2-1c (1) should include the requirement to accomplish essentiality coding of maintenance actions on end items. By incorporating essentiality coding in the logistics support analysis (LSA) process, the evaluation of the end item response to deferred maintenance can be easily accomplished and the development of annotated MACs will be facilitated. As previously mentioned, the MAC, with mission essential, deferrable and peacetime safety maintenance actions identified is key to the implementation of the contingency maintenance standard.
- (3) Paragraph 2-7 should include essentiality coding of maintenance actions on the end item as a requirement under maintenance support parameters and criteria. This will insure that LSARs will include essentiality codes in the LSAR 04, Maintenance Allocation Summary report which provides the basis for the MAC of the Technical Manual (TM).
- (4) Paragraph 2-11 should include essentiality coding repair actions on end items as part of the maintenance standard. The rationale is the same as for (2) above.
- (5) Paragraph 2-14 should include essentiality coding of repair actions on the end item as a policy for allocating maintenance operations and resources during combat operation or other

operations where the maximum operational availability of end items must be accomplished with limited maintenance resources.

- (6) Paragraph 3-2a should include essentiality codes for repair actions on end items in order to provide for the implementation of the contingency maintenance standard.
- (7) Paragraph 3-3f (2) should be expanded to include authorizing deferred maintenance. This will provide approval and guidelines for implementing the contingency maintenance standard.
- (8) The responsibilities for essentiality coding of repair actions on end items should be included in Appendix A. The study team views essentiality coding as a definite requirement that should be incorporated in the ILS process. The primary responsibility for essentiality coding should probably rest with the material developer. However, the combat developer must also participate in some key decisions and is responsible to ensure that essentiality coding data produced by the material developer meets the needs of the combat developer/user community.
- (9) Definition of the contingency maintenance standard, mission essential, deferrable, peacetime/safety and nonessential maintenance actions should be included in Appendix B.

3. Implementation Instructions

Chapter 3, Maintenance Operations of AR 750-1, was reviewed to determine whether or not the Contingency Maintenance Standard and implementing instructions could be incorporated. The study team agreed that devoting a separate chapter to the standard and its implementation would provide a document that would be more usable and would more clearly state policy, procedures and responsibilities. An outline of the proposed chapter(Chapter VIII) was therefore developed and is included in the report as Appendix B.

C. INTERFACING THE CONTINGENCY MAINTENANCE STANDARD WITH PRESENT MAINTENANCE METHODS

1. Background

The Option 3 simulation run substantiated that incremental deferral of deferrable and nonessential maintenance actions to permit concentration of available resources on mission essential actions precluded accumulation of unmanageable deferred maintenance backlogs. The analysis of Option 5, the recommended contingency maintenance standard, demonstrated that by introducing sound management practices at all levels and concentrating on the essentiality of maintenance actions for the repair of end items, available maintenance resources could be more efficiently and effectively utilized. The successful implementation of the contingency maintenance standard and its interface with current maintenance methods is dependent upon commanders, their maintenance managers, and on the material and combat developers who must provide the annotated MACs necessary to permit implementation. No significant changes to the maintenance structure or functions are included in the recommended contingency standard; however, changes may be necessary as more modularly designed equipment is introduced into the Army inventory.

2. The Role of the Commander

Commanders must work closely with maintenance managers to insure that repair priorities support operational needs. Commanders must also insure that the contingency maintenance standard is being applied properly over time to preclude the accumulation of unacceptable backlogs. The basic role of the commander can be translated into the following key tasks:

- (1) Insure that available maintenance resources are being focused on the equipment most required to meet operational needs.
- (2) Insure the maximum operational availability of equipment and a balanced force is being maintained through the most efficient use of available resources.
- (3) Insure that the incremental application of the contingency maintenance standard is being accomplished at the correct times and does not exceed 15 to 20 days of continuous application.

- (4) Insure that maintenance personnel and managers are properly trained and that cross training is accomplished to the extent possible to increase the transferability of maintenance skills.

3. The Role of the Maintenance Manager

Maintenance managers must keep commanders informed as to the status of equipment, the capabilities of the maintenance system, and of supply and maintenance shortfalls in addition to accomplishing the management of available maintenance resources. Based upon the decision of the commander and the capabilities of the maintenance system, maintenance managers must:

- (1) Focus available maintenance resources on equipment most required to meet operational needs.
- (2) Maintain the desired level and balance of operational equipment, i.e., proper ratios of tanks to APC, etc.
- (3) Apply the contingency maintenance standard incrementally to prepare for and support combat operations without accumulating unacceptable deferred maintenance backlogs.
- (4) Cross train available personnel to the extent possible.
- (5) Coordinate with supporting and supported maintenance managers at all levels to insure that maintenance workloads are properly distributed and that all available maintenance resources are being fully utilized.
- (6) Insure that priorities for the repair of reparable support demands.

4. The Role of the Material and Combat Developers

The primary role of the material and combat development community is to provide the maintenance personnel with tools needed to implement the contingency standard. This role is played out during new equipment development and product improvements through the Integrated Logistics Support (ILS) process and must culminate in MACs which clearly identify mission essential, deferrable, peacetime safety and if applicable, nonessential maintenance actions for repair of the end item. Secondly, the combat development community must insure that maintenance TOEs provide sufficient personnel with the required MOSs and support equipment necessary to accomplish

the current maintenance standard. Last, stockage policy must provide the levels of repair parts and DX items necessary to support combat operations during the transition from peace to war and subsequently to support wartime operations.

D. IMPACTS OF OPERATION IN OTHER THEATERS AND AREAS OF OPERATIONS

1. Background

Although the contingency maintenance standard was developed using a European scenario, it is equally as applicable to other theaters and areas of operation. This is not to say that maintenance workloads will not be affected by various climates and topographics. These variations may require adjustments to manpower and equipment authorizations and will generate different demands for repair parts and DX items. However, these variations do not effect the basic principles used to implement the contingency maintenance standard.

2. Maintenance Workloads

Operations in theaters where the threat, climate and topography differ widely will effect maintenance workloads in two ways. First, the number of mission essential maintenance actions may increase or decrease from one climatic zone to another. Secondly, the frequency of occurrence for some maintenance actions will increase or decrease depending upon the topography and conditions under which the equipment must operate.

a. Mission Essential Maintenance Actions

Increases or decreases in mission essential maintenance actions can be most easily identified by examining current MACs. For example, crew heaters and other equipment heating elements are not mission essential in temperate zones, except during winter. They are mission essential in Arctic zones. Conversely air conditioning and ventilation units are more critical for some items of equipment in tropical and hot desert climates. MOSs required to repair these items and the stockage of parts and DX items required to support maintenance operations may have to be adjusted to accommodate the increased or decreased workloads. This is

THE BDM CORPORATION

commonly accomplished at the present time through the use of the MTOE (Modified Table of Equipment) and recomputation of stockage levels.

b. Frequency of Occurance

The frequency of occurrence for parts and component failures entered into the LSAR and other basic RAM data bases reflect the norm. However, these frequencies can change significantly in various topographics and climates. For example in desert operations cleaning, lubrication and filter changes will increase to protect equipment from sand and dust. Failure attributable to sand and dust can also be expected to increase. In wet tropical climates, mildew, fungus, rust and rot can be expected to take its toll. Mountainous terrain and areas which lack decent roads and trafficability will also take its toll on tires and suspension systems. MOS authorizations and repair parts and DX stockage will have to be adjusted accordingly through the use of the MTOE and recomputation of stockage levels.

c. Threat

Different threats will yield different types and extents of combat damage. This in turn translates to variations in the types and numbers of repair actions, related repair parts, DX items and skills required to effect repairs. For example, in an environment where there are few anti-armor missiles but the use of mines is widespread, the frequency of maintenance actions, and corresponding demands for parts and skills related to the repair of suspension systems will increase. In the opposite situation the frequency of turret and hull damage will increase. In effect the frequency of occurrence of certain maintenance actions can be related to various threat environments. TOEs and stockage levels can be varied accordingly.

E. MAJOR COMPONENT AND ASSEMBLY USAGE

1. Background

While component and assembly usage in the form of DX items was quantified for each of the simulation runs discussed in Chapter III, the

relationship of usage to the contingency maintenance standard has not been specifically addressed. Additionally two other factors which will impact on usage rates bear mentioning. These factors are the type and duration of contingency operations and the impact of increased densities of modularly designed equipment.

2. Impact of the Contingency Maintenance Standard

Slight increases in demands for major assemblies and components may occur as the contingency maintenance standard is applied. Of the two, increases in demands for replaceable components will most likely be the greatest. These increases are attributable to two factors. First, even though deferred maintenance actions are not performed during the periods when the contingency standard is applied, managers will continue to requisition the parts, components and in some cases assemblies required to perform the deferred actions. This will be done to insure that the required parts/components are on hand when the deferred maintenance backlog is worked off. As a result, usage levels will be approximately the same as for the current maintenance standard. Secondly, as skills and resources are freed from deferred maintenance actions they will focus on mission essential maintenance actions and increase the number of mission essential maintenance actions performed during the period in which the contingency standard is applied. As a result, demands for parts/components/assemblies will increase correspondingly.

These increases should be neither significant nor unmanageable since they will be distributed over time as the contingency maintenance standard is applied incrementally. As a result, stockage policy will permit the required stockage level increases to be established.

3. Contingency Operations

Contingency planners will normally tailor maintenance support and modify maintenance support procedures for smaller contingency force packages that are to be engaged in limited operations of short duration. For example a reinforced brigade will normally be deployed with a very limited direct support maintenance capability. In the brigade example, direct support will most likely be limited to repair of end items by replacement

of faulty parts, modules, components and assemblies. The capability to repair reparable components and assemblies removed from the end items would not be deployed with the brigade. A similar approach might be taken with the deployment of a division sized contingency force package. The division would most likely be deployed without a general support maintenance capability or the capability to repair reparable removed from end items may be withheld. In both examples, the capability to repair reparable would have to be replaced by additional inventories of reparable that would be deployed with the force package.

As a general rule any time the repair of reparable is either deferred or the workload is placed on the next higher level of maintenance:

- (1) The next higher level must be capable of absorbing the additional workload.
- (2) The supply system must be capable of responding to increased demands for reparable previously made available by the maintenance system.
- (3) The transportation system and carrying capacity of the force package must be capable of transporting the increased volume of reparable.

4. Impact of Modularization

As previously mentioned in this chapter (paragraph B1) and in Chapter V, as the densities of modularly designed equipment increases, so will the demands and correspondingly the inventories of replacement components and assemblies. These increases will complicate not only the supply problem but the component/assembly repair problem as well.

While this area requires further examination, the study team agreed that the retention of the capability to repair components and assemblies at the direct support level may not be either the most efficient or effective approach. Skills, tools; sophisticated test equipment, fault isolation equipment and facilities as well as DX stockage levels at the direct support level would have to be increased. Even with the increases, these units would probably be unable to fully utilize the repair capability

THE BDM CORPORATION

since they will frequently be required to move. The Army may well be required to consider centralizing component and assembly repair capabilities in the Corps rear area or even in the COMMZ to get full utilization of skills, equipment and facilities. Stockage levels at the forward levels of maintenance would have to be increased. In effect, the function of the direct support maintenance unit may be changed to focus on repair of end items by replacement of easily removable components and assemblies and to support these operations with increased DX inventories. The general support maintenance function would be increased in the area of component and assembly repair.

CHAPTER VII
OBSERVATIONS

A. PURPOSE

The purpose of this chapter is to provide a summary of observations made during the course of the simulation runs and other analyses during the course of the MEMO study. Some of the observations have already been mentioned in preceding chapters and are discussed in greater detail here. While some of the observations pertain directly to the MEMO concept and its implementation, others deal with problem areas observed within the logistics system and which may warrant further study. The order in which the observations are presented in no way reflect orders of importance or magnitudes and should not be used to establish priorities.

B. SUPPLY POLICY

1. Background

Supply policy contained in AR 710-2 was used to determine the availability of repair parts and to construct an inventory of DX items in the initial simulation runs for the baseline. Order ship times (OSTs) currently experienced in USAREUR for ASL and NSL items were used to reflect supply and transportation system response times. The results of the initial simulation runs indicated that supply policy in conjunction with current OSTs was not responsive to the needs of the maintenance system. Excessive delays were experienced as the maintenance system waited for ASL, NSL and DX items required to accomplish repairs. Delays attributable to NSL items were the most excessive since NSL items were not available in the theater and had to be obtained from CONUS. The NSL problem was exacerbated by combat damage, which increased the number of NSL items required to accomplish repair actions.

To permit analyses of the current maintenance standard and the MEMO maintenance concept, the supply problem had to be overcome. The

availability of ASL and NSL items was increased, DX inventories were increased and OSTs were reduced. Even then, periodic delays attributable to NSL items were experienced and substantially degraded the operational availability of end items.

The steps taken to increase the availability of repair parts and replacement components and assemblies were necessary to permit the observation of the maintenance system as it performed under the current maintenance standard, the MEMO maintenance concept, and finally under Alternative 3 of the contingency maintenance standard. These steps do not effect the validity of the study results, specifically, comparisons made of the system response to workloads under the three maintenance standards. The requirement to make the changes to permit the system responses to be observed, simply points out that repair parts and replacement components and assemblies must be available before maintenance can be accomplished. The changes highlight the need to review current stockage policy to insure that wartime demands can be met.

2. Supply Policy Insights

Although the purpose of the MEMO study did not include an in-depth analysis of supply policy, some analysis was necessary to determine how shortfalls in supply could be overcome to permit the impacts of the MEMO concept to be observed. While the following observations are not conclusive, they do provide insights into the supply problem and identify areas where further analyses might be desirable.

a. Stockage Levels

The results of the simulation runs and subsequent analyses indicated that the depth and breadth of DX items and repair parts stocked in peacetime are insufficient to meet wartime requirements. While this is not a new problem, the extent of the problem bears further examination and could have far reaching impacts on stockage policy, unit TOE's and stockage levels maintained in peacetime.

Both the depth of stockage (quantities of each component or part stocked) and the breadth of stockage (number of line items authorized for stockage) are determined based upon demands over space and time. The

chasm that exists between what is stocked in peacetime and what needs to be stocked to meet wartime requirements stems from the relatively low demands experienced in peacetime as compared to the much higher demands that will occur during wartime.

During peacetime, demands for DX items and repair parts are relatively low since unit equipment is not fully utilized except during the preparation and conduct of annual training tests and a limited number of field training exercises. Even then, periods of full utilization are limited to a few days. The majority of the time, unit equipment remains idle in equipment parks.

Considering only the demands for DX items and repair parts attributable to equipment utilization, dramatic increases occur during wartime as units are employed and full equipment utilization becomes the rule rather than the exception. As equipment utilization increases the number of failures over space and time will increase correspondingly. For example, if the mean time between failures (MTBF) for a given component is 100 hours of operation and the equipment is operated 200 hours a year during peacetime, two failures of the component can be expected. In wartime if the equipment utilization is increased to 2000 hours of operation 20 failures of the component can be expected. This amounts to a quantum increase in the stockage level required to support wartime operations.

If steps are taken to adjust peacetime demands to more closely approximate wartime demands when applying the formula and add/retain criteria in AR 710-2, required stockage levels would increase significantly. This creates significant problems for the Army. First of all quantum increases in stockage levels in peacetime are expensive and it is difficult to justify their retention. Second, if they are increased to wartime levels, unit TOE authorizations of men and equipment (parts vans) will have to be significantly increased to enable units to manage and carry the increased stocks. Third, if stockage levels are not increased, wartime requirements cannot be supported from existing stocks and industry will most likely be unable to meet the resulting surge of demands.

THE BDM CORPORATION

b. Breadth of Stockage

While the preceding paragraph addresses the breadth and depth of stockage in general terms it focuses primarily on the problems associated with the depth of stockage. Wartime breadth of stockage deserves special attention.

AR 710-2 controls the breadth of stockage through the application of add/retain criteria. Specifically, if demands are below a certain level the item is not authorized in the ASL. It is an NSL item. Furthermore, NSL items are not authorized for stockage in overseas theaters.

While increased demands for NSL items can be expected as combat damage occurs, demands for NSL items will also increase significantly as equipment utilization increases in wartime. Analyses indicated that many of the items that were NSL items in peacetime will become ASL items as demands increase during combat. In other words, items that did not meet AR 710-2 ASL add/retain criteria in peacetime will meet it in wartime due to the increase in demands.

This change in status and increased demands will have the most significant impact in overseas theaters. First, the ASL items that were previously NSL will not be available in the theater until supply is received from the CONUS National Inventory Control Point (NICP). Second, as with surge requirements for other ASL items, the surge requirement for the newly qualified ASL items may overwhelm the NICP and industry.

c. Combat PLL

While the recent action outlined in DA Pamphlet 710-3 and DA Circular 700-18-2 is a step towards improving the support of combat operations, it does not completely solve the stockage problem. First of all it does not solve the problem of quantum increases in ASL stocks required to satisfy wartime demands. Secondly, it does not address the problems associated with manpower and equipment increases required to manage and transport increased stocks of DX items and repair parts. Further study is recommended in these areas.

THE BDM CORPORATION

C. MANPOWER AUTHORIZATIONS

1. Background

During the course of loading the MACATAK model for the simulation runs, half of the maintenance personnel authorized in the maintenance units were placed in each 12 hour shift to reflect 24 hour operations. In some cases, MOS authorizations were increased so that an equal number were available on each shift. As the initial runs were made, unacceptable shortages of some MOSs precluded completion of the simulation. As previously discussed, these authorizations were increased to enable the impacts of the MEMO concept to be evaluated.

2. Potential Problem Areas

The need to change authorizations for selected MOSs indicated that two potential problem areas may exist. First, maintenance unit TOEs must be constructed to support 24 hour operations in combat. Second, authorizations for some MOSs may be insufficient to support the long-term periods of increased and full equipment utilization that will be experienced in combat.

A third area which may warrant further examination is the authorization for critical MOSs. Critical MOSs in this case are those highly skilled MOSs such as the tank turret repairer who were being used to the fullest and their workloads were not reduced when the MEMO concept was applied. It appears that since these individuals are used to capacity and their workloads are not easily transferrable to other MOSs, the maintenance system is particularly fragile in this area. The loss of personnel with any one of these MOSs during combat would result in unacceptable degradations of equipment operational availability. Additionally, they do not appear capable of recovering from maintenance backlogs since they are fully utilized nearly all of the time during normal operations.

Taking into account these three potential problem areas it may be desirable to reexamine maintenance unit TOE authorizations to insure that:

- (1) Unit TOEs permit 24 hour operations for extended periods.

THE BDM CORPORATION

- (2) Unit TOEs provide the depth of critical MOSs necessary to sustain the force during periods of intense combat and to enable the unit to absorb some loss of critical personnel without degrading unit maintenance capabilities to unacceptable levels.

D. EQUIPMENT AUTHORIZATIONS

1. Background

During the initial simulation runs made to construct the baseline run, a shortage of lift equipment was experienced. To preclude unacceptable queues building in future simulation runs, the authorization for lift equipment was increased. Further analyses of maintenance unit TOEs indicated that other tools, portable test equipment and test measurement and diagnostic equipment (TMDE) may not be authorized in sufficient quantities to support combat operations or the forward support concept involving extensive use of maintenance support teams.

2. Potential Areas of Analysis

Although no in depth analyses were performed, it appears that maintenance unit TOEs should be analyzed to insure that the proper mixes of tools, test equipment, TMDE and lift equipment are present to support long term combat operations and forward support maintenance concepts involving the use of maintenance support teams in forward areas.

E. THE 42 SERIES FMs

1. Background

The 42 series FMs for the four items of equipment examined in the "H" series analysis were used in conjunction with the MTDf to analyze the MEMO concept. The contingency maintenance allocation charts (CMACs) identified mission essential, deferrable and nonessential maintenance actions for each end item. The MTDf provided the more detailed Reliability, Availability, and Maintainability (RAM) data required by the MACATAK simulation model. While the scope of the study did not include a detailed

analysis of the 42 series FMs, some analysis was necessary to determine why end items reacted differently when the MEMO concept was applied and to determine whether the 42 series FMs should be retained as separate publications, eliminated entirely, or incorporated into existing publications. This portion of the chapter addresses the retention of the manuals and discrepancies noted in the manuals during analyses.

2. Retention of the 42 Series FMs

The study team determined that while the content of the 42 series FMs should be retained, the need to maintain another set of individual manuals could be eliminated by incorporating the 42 series FMs into existing technical manuals and data bases. The need to retain the CMACs in the 42 series FMs can be eliminated by annotating the maintenance allocation charts (MACs) in existing publications. The more technical RAM data in the 42 series FMs can also be placed in existing publications for each end item or stored and maintained in a data base such as the MTDf. This approach permits the retention of the data in the 42 series FMs, but at the same time eliminates the need to maintain still another publication.

3. Discrepancies in the 42 Series FMs

The analyses of the 42 Series FMs was limited to FM42-9-9, FM42-9-5, FM42-9-2, and FM42-9-1 for the M-113A1, M-109A1, M-813, and M-60A1 respectively. In the course of the study, discrepancies were discovered in these manuals. For example, there did not appear to be continuity among the four manuals. This was evident in the high number of nonessential maintenance actions on the tank as compared to the relatively low number of nonessential maintenance actions on the other items. As was discussed in Chapter III, this contributed to the different behavior of the end items under MEMO.

There also appeared to be discrepancies in essentiality coding of maintenance actions in all of the manuals. In most cases, for example, the repair of a given component was classified as mission essential, while its replacement was classified as deferrable. This seemed to indicate that the

replacement of component should be considered as a last resort in spite of the component's mission essentiality. Logic would suggest that if repair is not possible, the component must be replaced without delay.

In both these areas, the problem seems to stem from the lack of a common definition or common methodology for determining essentiality of maintenance actions. For this reason the study team strongly suggests that all of the fifty-one published 42 series FMs should be thoroughly reviewed before they are used to annotate other MACs.

F. THE ESSENTIALITY CODING PROBLEM

1. Background

As discussed in the preceding paragraph, there seemed to be either a lack of common definition or the lack of a common methodology for determining the essentiality of maintenance actions. Additionally, questions were raised as to whether essentiality codes should be assigned to reparable components or whether the essentiality of their repair should be determined on a day to day basis by maintenance managers.

2. Essentiality Coding

Analyses of the essentiality coding problem led the study team to conclude that essentiality codes should be assigned only to those maintenance actions that pertain directly to the repair of the end item. Reparable components should be assigned essentiality codes by maintenance managers based upon availability of the items within the supply and maintenance systems and the demands for the items. Secondly, that decision tree logic should be used as the methodology for determining essentiality codes. Analysts also questioned whether there should be any nonessential maintenance actions per se.

a. End Item Repair vs Reparables

Where essentiality coding is concerned, the repair of the end item and the repair of reparable components for the end item should be treated as two separate and distinct problems. Those repair actions on the end item most directly effect the operational availability of the end item.

For example, if the engine of a tank fails and replacement is required, the tank is returned to service when the engine replacement is completed. The repair of the engine that has been removed will not affect the operational availability of a tank unless there are no other replacement engines available in either the supply or maintenance systems. Whether or not there are great demands for engines and whether or not there are sufficient engines available in the supply or maintenance systems will determine the resources devoted to engine repair. This is particularly true if these same resources can be used on more critical tasks involving repair and return of end items to service. Since demands and availability in combat can change drastically from day to day, the essentiality of repairing reparables, in this example tank engines, must be managed. A simple entry in the MAC or CMAC will not always correspond to operational needs.

b. Essentiality Coding Methodology

The decision tree logic used in the Department of Defense (DOD) Reliability Centered Maintenance (RCM) program provides a more disciplined approach that can be applied to the maintenance action essentiality coding problem. The RCM methodology (Figure VII-1) requires analysts to consider the effects that the failure of specific parts, components and replacement assemblies will have on the safety and ability of equipment to accomplish its mission or function. The yes and no decisions that the analysts are required to make determine the path taken in the logic tree and subsequently the maintenance procedures that should be followed.

When applied to the problem of maintenance action essentiality coding, the process is divided into two parts as shown in Figure VII-2. The first part is oriented towards determining the essentiality of the part, component or assembly being considered. The second part focuses on the essentiality of individual maintenance actions which pertain to the repair and return of the end item to service. The entire process is aimed at providing analysts with the essentiality coding information required to annotate the equipment MAC. It results in identifying those maintenance actions that are peculiar to a specific type operation or region (Block A), nonessential maintenance actions (Block B), deferrable

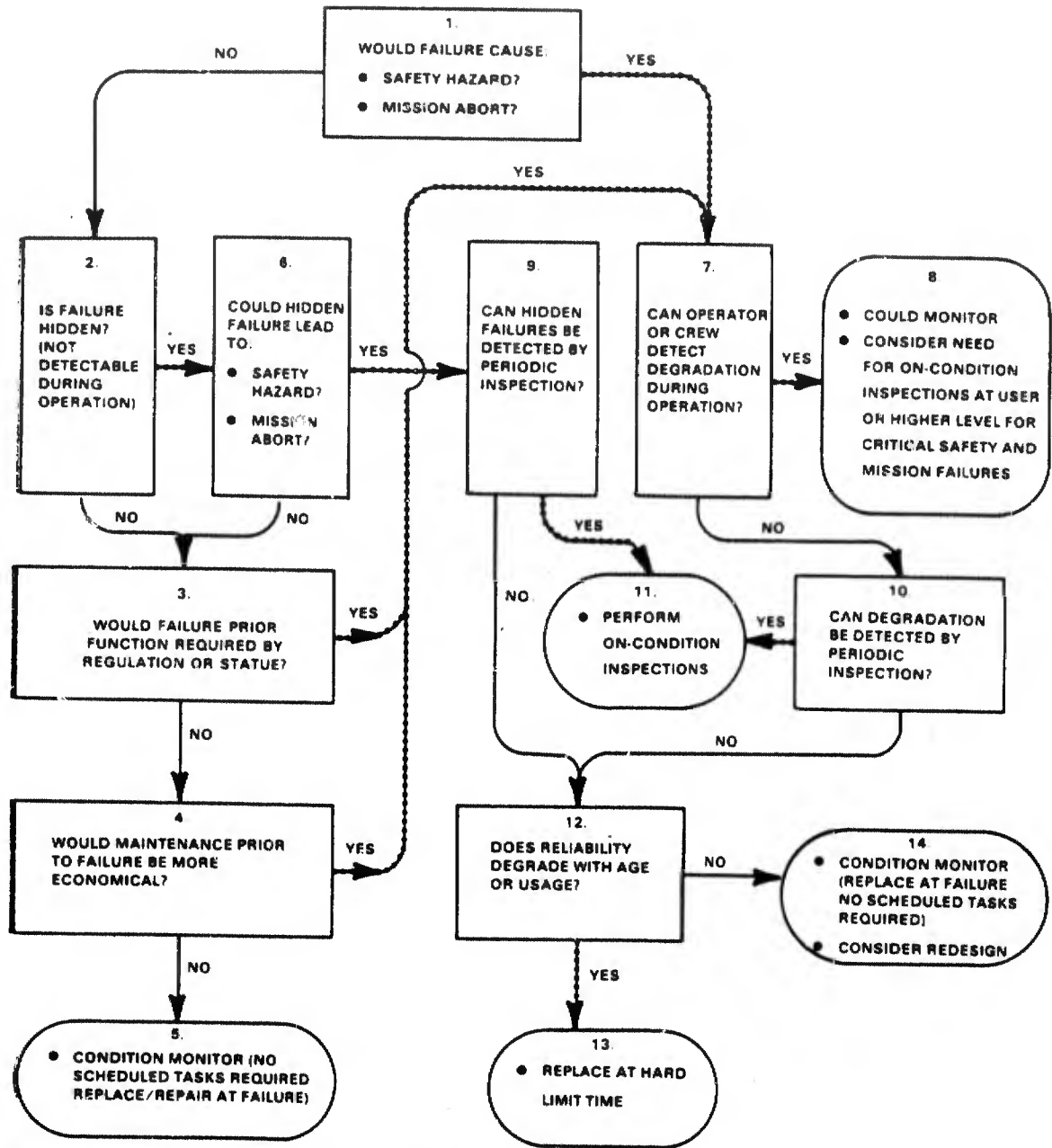

DEFINITIONS:

CONDITION MONITOR: OPERATOR/CREW MONITORS FOR DETERIORATION LEADING TO FAILURE OR OCCURANCE OF FAILURE.

ON CONDITION: INSPECTION OR TEST TO DETECTION DETERORATION LEADING TO FAILURE OR OCCURANCE OF FAILURE.

HARD TIME LIMIT: REPLACE AT FIXED TIME INTERVAL, OPERATING HOURS, MILES, OR ROUNDS FIRED.

Figure VII-1. RCM Decision Tree

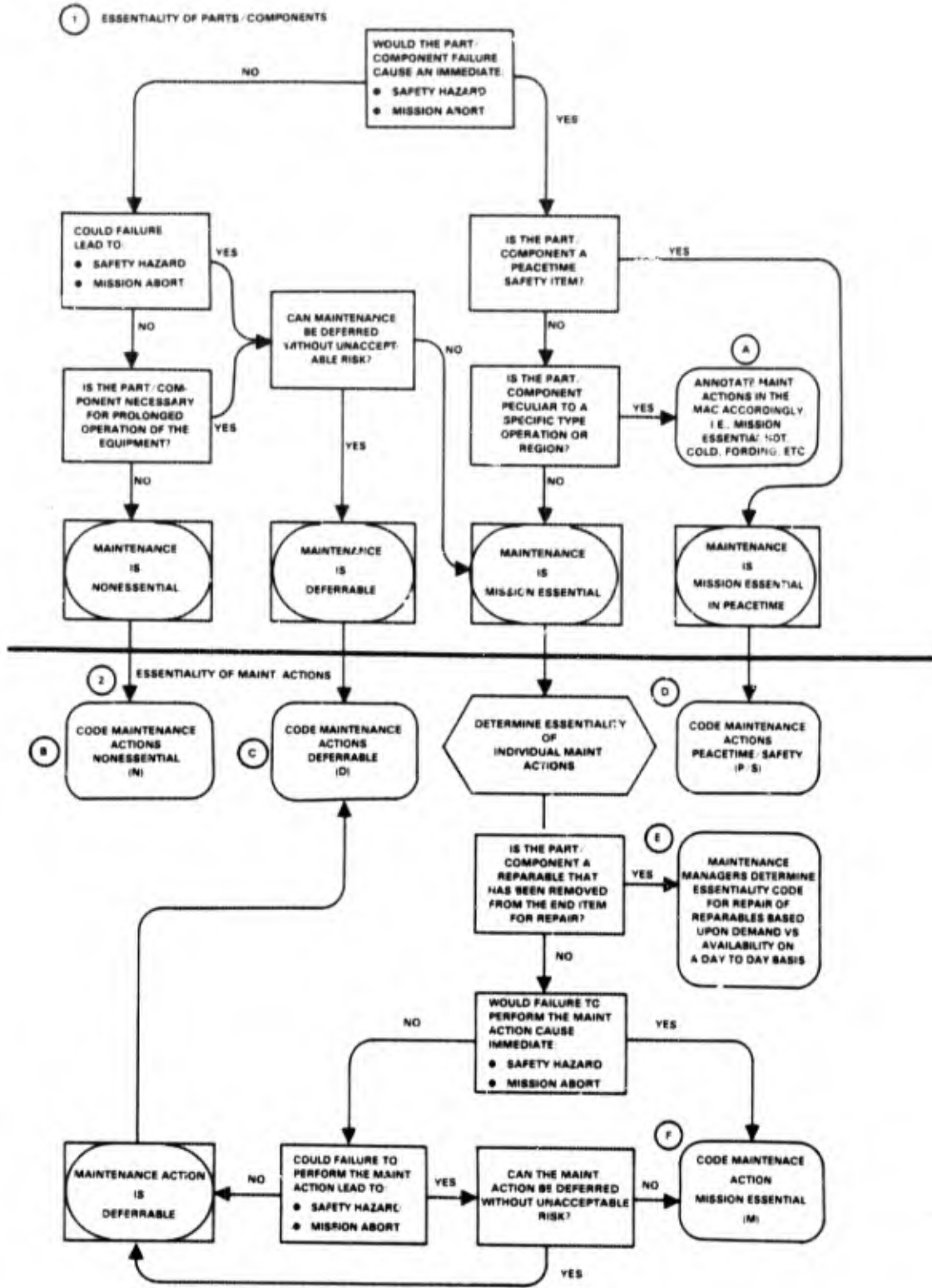

Figure VII-2. Maintenance Action Essentiality Coding Methodology

maintenance actions (Block C), peacetime/safety actions (Block D), repair or reparable removed from end items (Block E) and mission essential maintenance actions (Block F).

In this example, essentiality codes for nonessential (N), deferrable (D) and peacetime/safety (P/S) maintenance actions are derived directly from the essentiality of the parts, components, and assemblies to which they correspond. Maintenance actions relative to mission essentials must be examined individually since the study determined that the essentiality of repairing reparable removed from end items should be determined by maintenance managers based upon demands versus availability and since experience has shown that some maintenance actions relative to mission essentials can be deferred without unacceptable risk.

c. Nonessential Maintenance Actions

Designating maintenance actions as nonessential raises serious questions as to whether the component or assembly to which the maintenance action pertains is essential. This in turn raises the question as to why it was put on the equipment in the first place.

At the same time, we realize that certain peacetime safety items must be installed and maintained on equipment in peacetime. These items have nothing to do with the ability of the item to accomplish its combat mission but are more often designed to insure the safety of trainers and the civilian population during peacetime. Examples of these items are the lights, convoy flags, and placards that are required by German law for military equipment to use German roads and autobahns.

The study team recommends that it might be more acceptable to identify such items in the CMACs, as peacetime safety items (P/S). The study team also recommends that if items on equipment are determined to be nonessential in combat and are not peacetime safety items, consideration should be given to eliminating them.

THE BDM CORPORATION

G. LOGISTIC SUPPORT ANALYSIS REPORTS (LSAR)

1. Background

In this and other studies where LSAR data and the MTDf have been used, it was found that no procedures appear to exist to enter the LSAR data into the MTDf or another data base to permit its use in further analyses. Furthermore, there does not appear to be on-going efforts to update either the LSAR or MTDf.

2. Maintaining RAM Data Bases

The data contained in LSARs provide the logistics communities of DARCOM and TRADOC with an indispensable tool for determining support requirements, analyzing equipment, and measuring the effect of equipment modification and new maintenance support concepts. The study team believes that it would be in the best interest of the Army to institutionalize the maintenance of this data and to place it in a data base that is compatible with Army maintenance models.

H. SHOTLINE DATA

1. Background

Extensive efforts are being expended by The Army Material Systems Analysis Activity (AMSAA) and The Ballistic Research Laboratory (BRL) to develop shotlines on equipment. This data could be more widely used within the Army community if it was placed in a format compatible with Army maintenance models.

2. Maintaining Shotline Data

The study team believes that a standardized format could be developed through coordination between AMSAA and the TRADOC logistics community. In this way the shotline data could be more widely used to determine parts requirements and to determine wartime manpower requirements for maintenance unit TOEs.

CHAPTER VIII
SUMMARY AND APPLICATION OF STUDY RESULTS

A. PURPOSE

The purpose of this chapter is to provide a summary of the study results and to identify how the study findings and observations can be applied.

B. SUMMARY OF STUDY FINDINGS AND OBSERVATIONS

The following summary of study findings and observations consists of brief statements with references to the appropriate chapter or chapters of the report in which the findings and observations are discussed.

1. Study Findings

a. Validity of the MEMO Concept

The MEMO concept is valid if applied incrementally and in conjunction with proven maintenance management procedures. Continuous application of the MEMO concept (as codified in the 42 series FMs) throughout the 120 day transition period will result in deferred maintenance backlogs that overwhelm the maintenance and supply systems (Chapter III).

b. Recommended Contingency Maintenance Standard

Alternative 5 provides the best combination of proven maintenance management techniques and MEMO concept application. The alternative is applicable to "H" series and 1986 era equipment, permits realization of MEMO concept potentials, and is the most responsive to operational needs (Chapters IV and V).

c. Man-hour Costs

When compared to the current maintenance standard, the application of the MEMO concept as codified in the 42 series FMs and the contingency maintenance standard results in reduced maintenance workloads. However, these reduced man-hour requirements do not occur uniformly for all MOSs. Furthermore, these reductions should not be viewed as savings in the

context that TOE authorizations can be reduced or that shortages are acceptable. First, the hours saved by deferring deferrable maintenance actions will most likely be used to perform additional mission essential actions. Second, the MOSs will be required to accomplish the deferred maintenance backlogs (Chapters III and IV).

d. Material Costs

When compared to the current maintenance standard, the application of the MEMO concept as codified in the 42 series FMs and the contingency maintenance standard does not result in a reduction of requirements for repair parts and reparable components and assemblies. First of all, the repair parts and reparable components and assemblies for deferred maintenance actions are required to accomplish deferred maintenance backlogs. Secondly, additional repair parts and reparables will most likely be required in an earlier time frame to accomplish the increased number of mission essential maintenance actions that can be performed as a result of deferring other actions (Chapters III and IV).

e. Policy, Procedural, and Doctrinal Impacts

The recommended contingency maintenance standard has minimal impact on current maintenance policies, procedures and doctrine. Initial provisions for implementation of the contingency maintenance standard can be accomplished by relatively minor changes to AR 750-1 and supporting documents (Chapter V).

f. Interfaces

Ease of interface with current maintenance methods was a key consideration in the development of the recommended contingency maintenance standard. Incorporating recommended changes to AR 750-1 emphasizing the need for sound maintenance management and providing annotated MACs will provide the guidance and management tools necessary for interface (Chapter V).

g. Operations in Other Theaters

Operations in other theaters such as Korea, and Southwest Asia and the conduct of other contingency operations do not affect the application of the recommended contingency maintenance standard. Variations in workloads attributable to different threats, climates, and topographies can be expected, but are independent from the recommended contingency maintenance standard (Chapter V).

h. Impacts on Logistics Systems

The implementation of the recommended contingency maintenance standard will have little impact on the logistics systems. Tailoring of logistics support packages for contingency operations can necessitate that stockage levels of repair parts, components and assemblies and unit carrying capacities be increased when component and assembly repair capabilities are not deployed. Modularization may also necessitate increased stockage levels of reparable particularly at the direct support level and the centralization of component and assembly repair at the general support level. However, neither tailoring nor restructuring of direct and general support functions are attributable to the recommended contingency maintenance standard (Chapter V).

2. Study Observations

a. Retention of the 42 Series FMs

The need to maintain the 42 series FMs can be eliminated by annotating the MACs in current equipment TMs and incorporating the other contents of the 42 series FMs into appropriate maintenance publications. While the 42 series FMs can be used to annotate MACs, the 42 series FMs should be thoroughly reviewed to insure that they are current and to eliminate discrepancies (Chapter VII).

b. Stockage Policy

Current add-retain criteria in AR 710-2 combined with the formula used to calculate authorized stockage levels results in the breadth and depth of stockage in peacetime that appears to be substantially less than the levels required to support wartime operations. These shortfalls may far exceed the capabilities of the supply system and industry to meet surge

THE BDM CORPORATION

demands that may occur during transition and war. Current efforts to allow stockage of non-demand supported combat ASL/PLL do not appear to be adequate (Chapters III and VII).

c. NSL

During transition to war and war, many NSL items will become ASL due to increased equipment utilization, combat damage and corresponding increased demands. This will pose a serious problem in overseas theaters in which NSL items are not stocked. Current efforts to allow stockage of non-demand supported items may not be adequate (Chapters III and VII).

d. Unit Equipment Authorizations

Units may not be authorized sufficient equipment to support required maintenance operations. Shortages of lift equipment caused significant queues during initial attempts to simulate the current maintenance system. Units may also require substantial increases in trucks and vans for repair parts as stockage levels must be increased to support wartime operations (Chapters III and VII).

e. Unit Personnel Authorizations

Units do not appear to be properly organized for prolonged 24-hour operations. Shortages of some MOSs were experienced during initial attempts to simulate the current maintenance system. Authorizations may also have to be increased for some critical MOSs to provide the maintenance system the depth, redundancies and resilience required to meet wartime demands and ensure system survivability (Chapters III and VII).

f. Essentiality Coding of Repairable Repair Actions

Maintenance actions for the repair of repairables should not be assigned essentiality codes in MACs. The essentiality of repairing repairables should be determined by maintenance managers on a day-to-day basis, based upon demands and availability of repairables in the supply and maintenance systems. Maintenance actions assigned essentiality codes in MACs should be limited to those which involve repair and return of the major end item to service (Chapter VII).

THE BDM CORPORATION

g. Essentiality Coding Methodology

The decision tree logic used in the DOD Reliability Centered Maintenance (RCM) program offers the disciplined approach required to determine essentiality codes for maintenance actions. This methodology should be applied when determining essentiality codes for maintenance of new equipment and should be used to verify the essentiality codes contained in the 42 series FM CMACs. The Army should consider taking the steps necessary to formalize the use of this methodology and to begin its application (Chapter VII).

h. Essentiality Codes

The designation of some maintenance actions as "NONESENTIAL" raises serious questions as to whether the component or assembly to which they pertain should have been included in the equipment procurement. At the same time, peacetime safety items were not identified as such (Chapter VII).

i. Logistics Support Analysis reports (LSAR)

The LSAR appears to offer the Army considerable potential for analyzing equipment, maintenance support concepts and for validating TOE and parts requirements. There does not appear to be a procedure for maintaining, updating or fully utilizing the LSAR data (Chapter VII).

j. The Maintenance Task Demand File (MTDF)

The MTDF provides a format compatible with the LSAR and has proven a useful tool in analyzing maintenance problems. It appears that a procedure to use LSAR data for new and product improved equipment to expand the MTDF and a procedure to update the MTDF would provide a valuable analytic tool to the Army (Chapter VII).

k. Shotline Data

The shotline data currently developed by AMSAA and BRL could be more widely used if a standard format existed. The MTDF appears to be the logical candidate (Chapter VII).

C. APPLICATION OF STUDY RESULTS

1. Background

The primary efforts of the MEMO study were to determine the validity of the MEMO concept and to develop a proposed contingency maintenance standard that will permit an efficient and effective transition from peace to war with the maintenance structure at reduced strength. The objectives were to determine the validity of deferring nonessential maintenance, determine the contingency maintenance standard to be adopted during the 120 day transition period, and to determine the risks and trade-offs associated with adopting a deferred maintenance approach during the transition period. Ultimately, the results of the MEMO study are to serve as a basis for material stationing and force structure for maintenance units.

While the study results answer the basic questions in the contract statement of work, several other observations were made during the course of the study. These observations deal with basic conditions that are requisite to accomplishing required maintenance workloads regardless of the maintenance support concept being employed. For example, supply policy must provide for the inventories of parts, components and assemblies that will be required during transition to war. Unit TOEs must also provide for the equipment necessary to transport these inventories and the tools, test equipment, TMDE and trained personnel necessary to accomplish required maintenance workloads.

The application of the study results are discussed in subsequent paragraphs. In those instances where problem areas identified during the course of the study were beyond the scope of the study, the need for further study is identified. Several of these problem areas concern very basic problems that exist in the supply and maintenance systems and should be examined regardless of whether or not the proposed contingency maintenance standard is incorporated into Army maintenance doctrine.

2. The Proposed Contingency Maintenance Standard

The proposed contingency maintenance standard provides commanders and maintenance managers the means to increase the operational availability of equipment over those levels that could be achieved using the same available maintenance resources while operating under the current maintenance standard. While the contingency maintenance standard enables the maintenance system to be more responsive to operational needs, it should be applied incrementally to preclude the accumulation of overwhelming deferred maintenance backlogs. Because of this, the contingency maintenance standard should not be viewed as the panacea for overcoming peacetime shortages of maintenance personnel, parts, components, assemblies and maintenance units during the transition period. The following actions can be taken to facilitate implementation and interface of the proposed contingency maintenance standard. In most cases the actions would be beneficial to the Army regardless of whether or not the proposed standard is adopted.

a. Changes to Policy and Doctrine

The changes to AR 750-1 and supporting documents recommended in Chapter VI and Appendix B of this report should be made to recognize the contingency maintenance standard as an approved maintenance practice, define the standard, and prescribe its implementation.

b. Essentiality Coding Methodology

The essentiality coding methodology prescribed in Chapter VII should be incorporated into Army policy and into ILS procedures. It should then be applied to all new items of equipment and used to review all 42 series FMs.

c. Elimination of 42 Series FMs

Once reviewed, the 42 series FMs should be used to annotate existing MACs. The other contents of the 42 series FMs should be incorporated into appropriate maintenance publications. In this manner the need to maintain the 42 series FMs as separate publications can be eliminated.

d. Improved Transferrability of Skills

The survivability of the maintenance system can be increased and the potential benefits of the proposed contingency maintenance standard

more fully realized if steps are taken to increase the transferrability of maintenance skills. Specifically, the capability of maintenance personnel with one MOS to assist others with different MOSs is needed. This is particularly true for those MOSs least affected by the application of a deferred maintenance concept. This may be accomplished by increasing the emphasis on cross training in maintenance courses. The BDM study team does not believe that this particular problem should be left to on the job training (OJT), since there will not be time for OJT in war. This area requires further study.

e. Critical MOSs

MOSs with highly specialized training are part of the skills transferrability problem, but deserve special attention. These MOSs are least affected by a deferred maintenance concept and are critical to accomplishing mission essential workloads. They are also most difficult to retain in the Army due to their high level of training and high demand in civilian industry. One solution may be to increase the transferrability of skills. Another may be to increase TOE authorization to provide the maintenance system greater resilience and survivability.

f. Maintenance Management Training

One of the key factors in the successful implementation of the proposed contingency maintenance standard is the ability of key maintenance supervisors to manage workloads. Training may have to be increased for maintenance managers. This area requires further analysis to determine how maintenance managers are performing in the field, what management tools they have, and the adequacy of management training.

3. Force Structure and Stationing

As with the actions discussed above, some of the actions which impact on force structure and stationing are directly related to the implementation of the proposed contingency maintenance standard while others pertain to basic problem areas observed during the course of the study. The problems of critical MOSs and MOS cross training have already been addressed in paragraphs 2d and e above. The resolution of these problem

areas may have some impact on unit TOE authorizations. Other areas are addressed below.

a. Unit Manpower and Equipment Authorizations

During the initial attempts to measure the responsiveness of the current maintenance system to workloads that occurred during the transition period, some adjustments had to be made to manpower and equipment authorizations. This indicated that maintenance TOEs may not provide adequate personnel and equipment authorizations that are required to support 24 hour operations in a combat environment. The scope of the study did not permit sensitivity analyses to be conducted that would determine specific manpower and equipment requirements. The analyses performed and the results of initial simulations did indicate the need to validate current TOE authorizations.

b. Augmentation Packages Versus Contact Teams

Current forward support maintenance concepts were analyzed during the course of the study to evaluate the current maintenance standard and to develop the proposed contingency maintenance standard. The deployment of augmentation packages to where they are most needed as opposed to the use of contact teams may provide a more productive approach to "repair forward" requirements. The augmentation packages would consist of maintenance personnel, tools, test equipment, portable TMDE and the parts, components and assemblies required to accomplish repairs. Contact teams currently have a very limited repair capability and are primarily concerned with diagnosing damage and failures. The augmentation package concept may bear further consideration and analyses.

c. Impacts of Modularization

Increases in new modular designed equipment may have the most far reaching impact on maintenance force structure and material positioning. Inherent in modular design is a quantum increase in the number of repairable components that must be handled by the maintenance and supply systems. This increase may necessitate the reduction or elimination of component repair at the direct support level in favor of increased DX stockage levels, and the centralization of component repair in the ccrrps

rear or at echelons above corps (EAC). Although it has no bearing on the validity of the proposed contingency maintenance standard, this potential problem area should be examined in current maintenance restructuring studies or in a separate study.

d. Stockage Levels and Locations

Current stockage policy as provided in AR 710-2 and the inventories created in peacetime do not appear to be adequate to support wartime demands and will undoubtedly cause severe degradation of fleet operational availability during the transition period. Additionally, current approaches to establishing combat PLL and ASL may not be adequate, particularly to overcome the NSL problem anticipated in overseas theaters. While the impacts of supply policy shortfalls were observed during the course of the study, the scope of the study did not permit analyses that are required to determine the changes that are necessary to establish required stockage levels and locations. Such a study is recommended and should include addressing the increased stockage of reparable that will be required for new modular designed equipment.

4. Army Maintenance Analysis Capability

Many of the problem areas discussed above require an extensive Army maintenance analysis capability. During the course of the study the BDM study team observed that the capability could be increased significantly by making better use of data, automated data bases, and simulation modeling capabilities that currently exist. For example, the LSAR for each new item of equipment contains a great deal of information that can be used in performing required analyses. The same is true for the hotline data produced by AMSAA and BRL. If the LSAR and hotline data were placed in an automated data base such as the MTDf and provisions were made to update the data with field use and test data, the analytic capability of the Army would be increased tremendously at little additional expense to the Army. This area should be explored as soon as possible.

APPENDIX A
THE MACATAK MODEL

A. PURPOSE AND USE

The MACATAK simulation model was developed to analyze maintenance support concepts and the survivability/vulnerability of the maintenance system by quantifying the system response to workloads as a function of space, time and operational items returned to the fleet in the conventional, chemical and nuclear environments. The model was constructed to provide for operation in the peacetime mode and transition to wartime by applying the combat damage module which can be used to degrade both the fleet and the maintenance system. MACATAK can be adapted to represent divisional and non-divisional maintenance systems.

In its divisional configuration, the model represents the organizational, forward direct support, rear direct support and general support levels of maintenance. The forward and rear direct support nodes are represented in great detail while the organizational and general support nodes are represented in lesser detail. The forward and rear direct support nodes of the model can represent different maintenance levels for various applications of the model.

The model was designed to represent a wide range of maintenance demands and system degradation. Varying demand and degradation patterns may be specified through the combat damage module. Attacks on the fleet generate increased combat damage workloads on the system. Attacks on the system are made by specifying various conventional, chemical, and nuclear effects and thus degrading the system response capabilities.

The normal mode of operation for the MACATAK model is a baseline run which represents a maintenance system operating under a given set of conditions. The baseline run is followed by a series of iterative runs where parametric analysis is used to measure the effects of various concepts and fleet and system degradations. A comparative analysis can then be performed on the system responses under varying conditions.

THE BDM CORPORATION

B. GENERAL CHARACTERISTICS

The MACATAK model is a discrete-event, stochastic simulation model consisting of three primary type maintenance nodes at which organizational, forward direct support, and rear direct support operations are simulated. The fourth type node is the general support maintenance node which simulates performance of general support maintenance tasks and direct support maintenance overflows. Figure A-1 graphically portrays the nodes of the MACATAK model in a divisional configuration. In Phase I of the MEMO study 1st, 2nd, and 3rd brigade fleets consist of M-60s, M-113s, and M-813s. The division rear fleet consist of all the M-109s, plus M-813s and a limited number of M-113s as illustrated in Figure A-2.

Organizational maintenance nodes represent the aggregated elements of the division maintenance system operating at organizational level (level 1) in support of a specified array of equipment or fleet. Specifically, organizational Nodes 1-3 (ORG01, ORG02, and ORG03) represent the aggregated organizational maintenance elements of each brigade. The array of equipment, or fleet, supported consists of the equipment assigned to each brigade. ORG04 represents the aggregated organizational maintenance elements of the units found in the division rear area. The array of equipment, or fleet, supported consists of the equipment assigned to the units in the support area.

Forward Direct Support (FDS) Maintenance Nodes FDS01, FDS02, and FDS03 represent elements of the maintenance system operating in direct support of a specified array of equipment in forward areas. For example, the forward support maintenance companies of a maintenance battalion, provide forward direct support (level 2) maintenance to the brigade fleets.

The rear direct support node, RDS01, represents elements of the maintenance system operating in the division support area. RDS01 provides rear direct support maintenance (level 3) for all equipment fleets in brigade and level 2 and 3 support for the fleet in the division rear area.

THE BDM CORPORATION

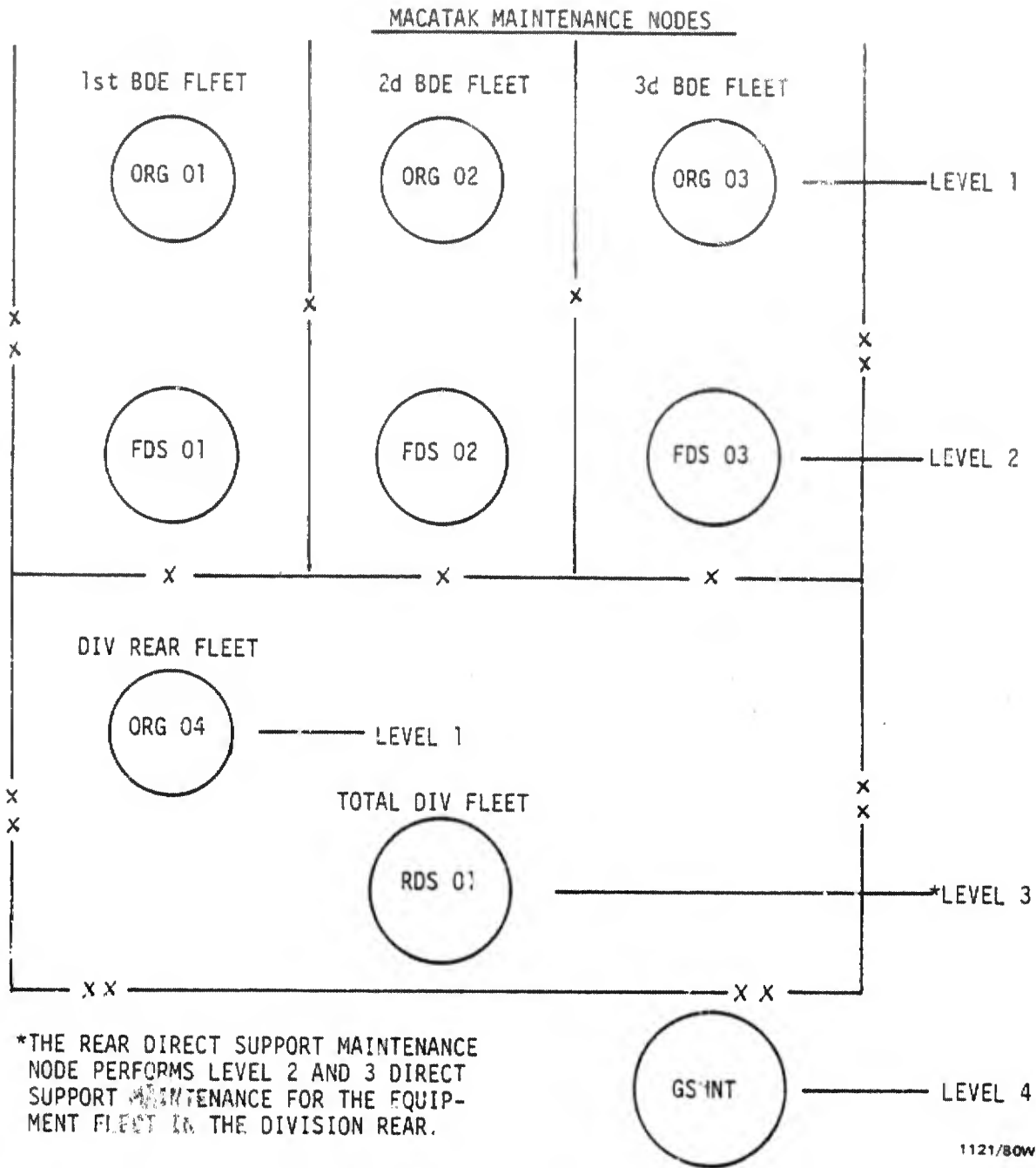

Figure A-1. MACATAK Maintenance Nodes (Divisional Configuration)

MEMO STUDY — PHASE I — MACATAK CONFIGURATION

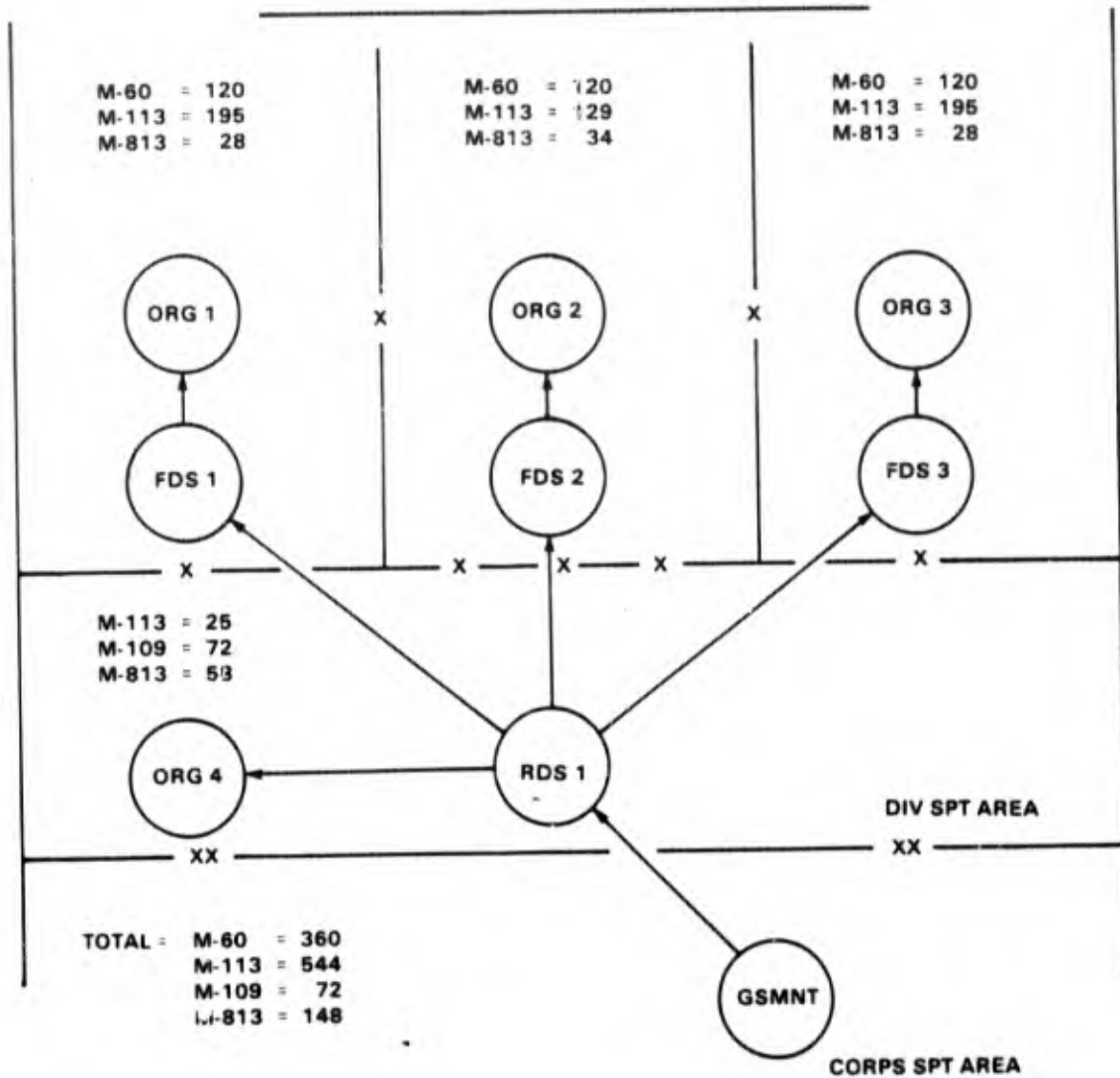

Figure A-2. MACATAK Model Configuration

The General Support Maintenance Node (GSMNT) represents the general support elements of the corps level maintenance system (level 4), operating in general support of the division.

Overloads of the direct support nodes can be caused either by attacks on the fleet or attacks on the maintenance system or a combination of both. Overloads cause queue build-ups and overflows of work. Normally the overflow from the forward direct support nodes flow to the rear direct support node and from the rear direct support node to the general support node. This is shown in Figure A-3.

Destruction of nodes causes diversion of workloads to occur. For example, destruction of a forward direct support node can cause the work load to be shifted to another direct support node or to the rear direct support node. Destruction of the rear direct support node can cause diversion of incoming workloads from forward direct support nodes to the general support node. This is shown in Figure A-4.

The maintenance workload consists of the number of maintenance actions that must be performed to return operational items to the fleet. During the baseline run failures are based upon frequency distribution data, specifically Mean Time Between Failure (MTBF) for each end item component. During the peacetime run, failures occur on a one for one basis, i.e., one reliability failure on one end item. During wartime, shotline data are used to select a number of maintenance actions for each combat damaged end item. A more detailed discussion of this process is included in subsequent paragraphs.

The model is a sophisticated simulation model with complex logic to handle the many decisions arising from maintenance workloads, overflows and diversions. The model enables the user to study the interactions that occur within the maintenance system, from level to level, and between the maintenance and supply system. In addition, conditions relative to fleet degradation and maintenance system degradation can be altered during the model runs. The model then reacts to the new conditions and the cause and effect relationships can be studied. The basic measure of effectiveness is

MACATAK WORKLOAD OVERFLOWS

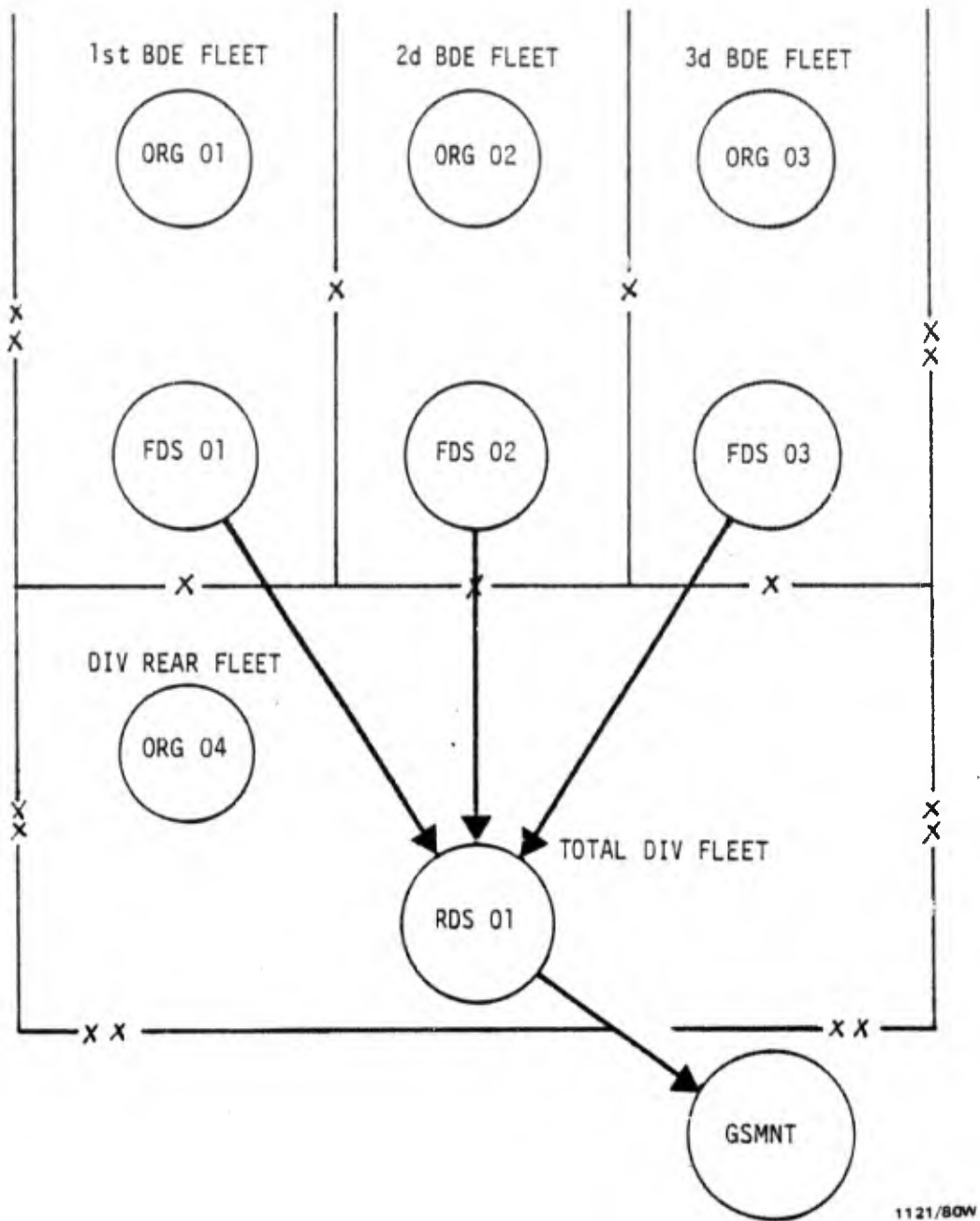
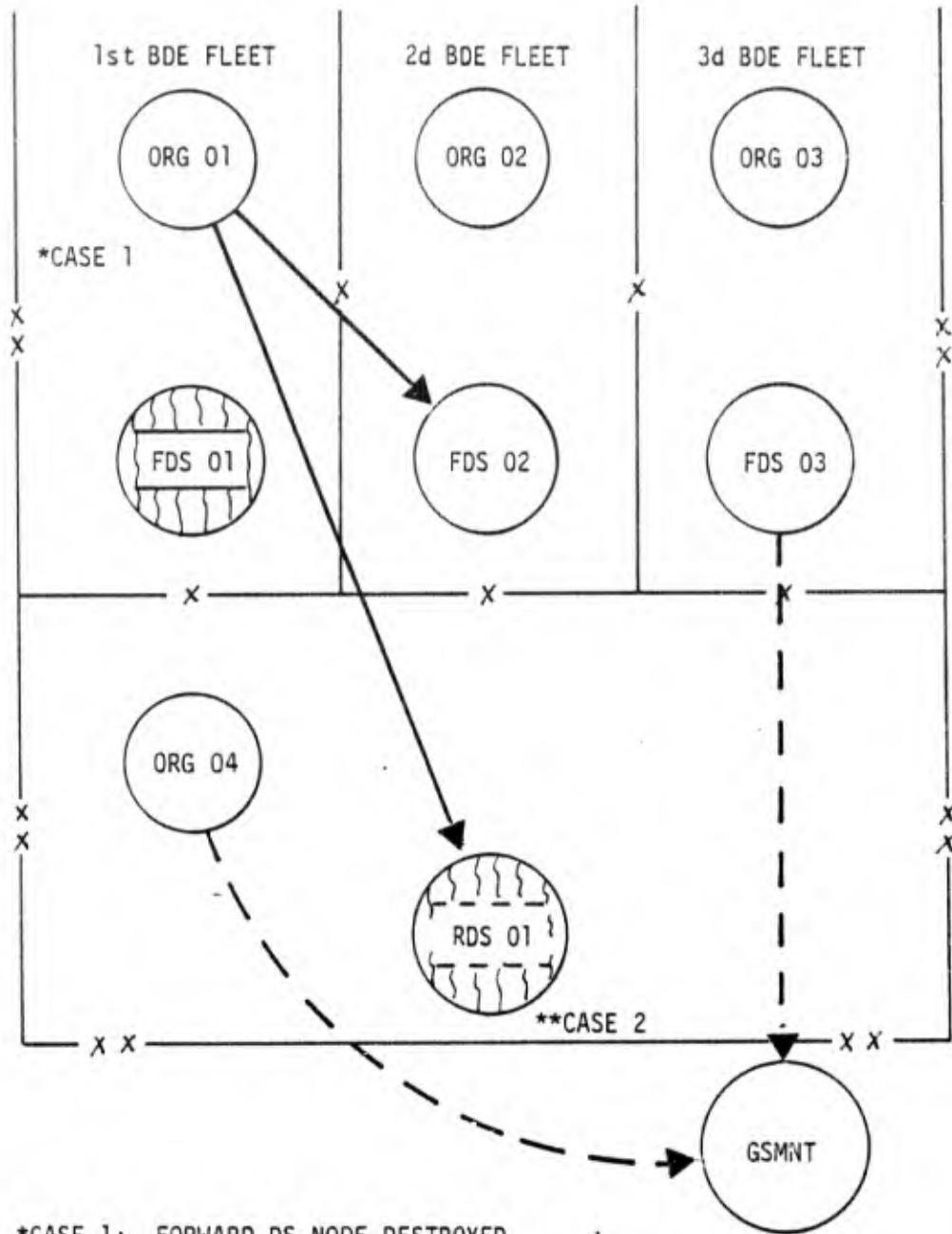

Figure A-3. MACATAK Maintenance Workload Overflows (Divisional Configuration)

MACATAK WORKLOAD DIVERSIONS



*CASE 1: FORWARD DS NODE DESTROYED
 WORKLOAD IS DIVERTED TO NEAREST LATERAL
 FORWARD DS NODE OR TO THE REAR DS NODE

**CASE 2: REAR DS NODE DESTROYED
 WORKLOAD IS DIVERTED TO GENERAL SUPPORT NODE

1121/80W

Figure A-4. Macatak Maintenance Workload Diversions (Divisional Configuration)

the number of operational end items returned to the fleet. The capabilities of the model provide a tool to analyze new concepts and the vulnerability/survivability of the maintenance system.

C. MODEL DESCRIPTION

1. Inputs and Data Base

a. Introduction

1) Background

The MACATAK model is highly sophisticated and is designed to simulate a maintenance system in a significant level of detail. Because of this, an extensive amount of detailed input data is required. MACATAK input data falls into three categories: maintenance system data, end item reliability data drawn from an automated data base, and data applied to enable transition from peace to war and to effect changes to fleet size and systems capabilities.

2) Maintenance System Data

Maintenance system data describes the location of maintenance nodes, recovery and evacuation times, and initial maintenance system resource levels, such as MOS authorizations. This data, for the most part, can be extracted from TOEs, supply policy documents and the results of experience, field tests or other simulations.

3) End Item Reliability Data

MACATAK was designed to be compatible with other existing and emerging models and to the extent possible, draw data from an existing data base.

The Maintenance Task Demand File (MTDF) is the data base currently used by MACATAK since it provides the maintenance data in the level of detail required by the model and has significant potential for other maintenance applications. During the baseline run, the MTDF serves two important functions:

First, it provides the data necessary to generate the baseline maintenance workload by specifying maintenance actions that must

be performed. These maintenance actions are referred to as reliability failures and occur at a rate based upon the Mean Time Between Failures (MTBF) as calculated from the MTBF for each component of the end item being considered. Reliability failures occur on a one-for-one basis--one reliability failure on an individual end item.

The second function of the MTDf is to provide all of the other data that is required by the model to accomplish each maintenance action. For example, the MTDf provides the following type data relative to each maintenance action: level of repair; whether lift equipment is needed; whether a contact team can accomplish the action; MOSs required; what maintenance action is required; time needed to complete the action, etc. This data is used by the model to realistically simulate actions that must be taken to effect repair, drawing from the maintenance resources of the maintenance system.

4) Combat Attrition and Damage

During wartime, the maintenance problem becomes more complex. In addition to reliability failures which continue to occur as in peacetime, the effects of conventional, chemical and nuclear attacks on both the operational fleet and the maintenance system must be taken into account. The problem is further complicated by combat damage inflicted on the end items supported by the maintenance system. The model, therefore, makes three provisions for these problems.

First, the combat damage module takes into account both attacks on the fleet and combat damage. Attacks on the fleet are considered through the application of attrition data expressed in terms of end items lost to combat and those that are recoverable and reparable. Combat damage is considered through the application of shotlines to each damaged end item. While reliability failures occur on a basis of one failure--one end item non-operational, combat damaged items will normally have multiple failures, some of which can be repaired independent of others and some of which may require repair in sequence. Shotlines are selected at random for each combat damaged end item and identify a number of specific maintenance actions that must be accomplished.

Attacks on the maintenance system (which were not "played" in this study) and other effects that can hamper maintenance efforts are taken into account by changing specific data elements used by the model. For example, if the recovery time being experienced by a unit is significantly long, the recovery delay time can be increased accordingly. Casualties and damage to a maintenance unit can also be taken into account by reducing the number of skills and maintenance equipment available. These are only a few examples of how effects can be applied.

b. Maintenance System Data Elements

Table A-1 provides a list of the baseline data elements and data sources. The purpose of the table is to provide insights into the order of magnitude of the baseline data input requirements and where the required data can be obtained. A more detailed presentation of the input data requirements and their use in the MACATAK model is contained in the MACATAK User's Manual.

c. Maintenance Task Demand File Data Base

The MTFD is item based--that is, it is segmented by major end items. The format or structure of the MTFD was designed to provide essential maintenance data for any end item contained in the MTFD data base. The MTFD is maintained on magnetic disc files at the TRADOC DPFO at Fort Leavenworth, Kansas. The BDM Services Company, Final Report, Design and Development Maintenance Task Demand (MTD) File (Phase II), Volume IV: Data Base Contents (BDM/FT.LEE-FR-78-015) dated 10 February 1978, describes the MTFD and how it was developed.

The MACATAK model requires most, but not all of the data contained in the MTFD for the items represented in the model. The data required by the MACATAK model is obtained by using the preprocessor. The data elements obtained for the MACATAK model by the preprocessor are listed in Table A-2.

d. Combat Attrition and Damage

1) Combat Damage Module (Attacking the Fleet)

The combat damage modules provide two basic functions: First, they apply combat attrition data to the fleet supported by each node

TABLE A-1. BASELINE DATA REQUIREMENTS

<u>ELEMENT</u>	<u>DATA</u>	<u>SOURCE</u>
1. END ITEMS TO BE SUPPORTED	NOMENCLATURE & LINE NUMBER	SPECIFIED BY USER (MUST BE IN MTFD)
2. END ITEM SUPPORT PRIORITY	PRIORITY I THRU X	SPECIFIED BY USER
3. END ITEM USAGE INTENSITY	NUMERIC VALUE (0-1)	SPECIFIED BY USER
4. FLEET COMPOSITION	NUMBER OF EACH TYPE END ITEM BY NODE	- FORCE COMPOSITION - TOE AUTHORIZATION
5. NODE PRIORITY	NUMERIC VALUE (1-3) ORG, FDS, RDS	SPECIFIED BY USER
6. SKILLS	NUMBER OF INDIVIDUALS BY MOS AT FDS AND RDS NODES (SKILLS ARE NOT SIMULATED AT ORG AND GS NODES)	MAINT UNIT TOE
7. LIFT EQUIPMENT	NUMERIC VALUE AT FDS AND RDS NODES (LIFT EQUIPMENT IS NOT SIMULATED AT ORG AND GS NODES)	MAINT UNIT TOE
8. DIRECT EXCHANGE (DX) INVENTORY	INVENTORY OF LINE ITEMS	PRE-PROCESSOR BASED UPON AR710-2 CRITERIA OR ACTUAL UNIT INVENTORIES
9. PLL/ASL AND NSL AVAILABILITY THRESHOLD	PERCENTAGE (DEMAND SATISFACTION)	AR 710-2
10. ORDER-SHIP TIMES (OST)	DELAY TIME	
- PLL/ASL	- NUMERIC VALUE (DAYS BY NODE)	SPECIFIED BY USER OR FROM DSS REPORTS
- NSL	- DO	DO
- MAJOR END ITEM	- DO	SPECIFIED BY USER
11. DIRECT EXCHANGE ITEM RESUPPLY	DELAY TIME	
- FROM DS TO ORG NODE	- NUMERIC VALUE (HOURS OR DAYS)	SPECIFIED BY USER
- FROM SUPPLY SYSTEM TO DS NODES	- NUMERIC VALUE (DAYS BY NODE)	USE PLL/ASL OST (ITEM 10)
12. NOTIFICATION TIME	DELAY TIME	SPECIFIED BY USER
13. RECOVERY TIME	DELAY TIME	SPECIFIED BY USER OR OC&S BATTLEFIELD RECOVERY MODEL DATA
14. CONTACT TEAM TRAVEL TIME	DELAY TIME (BY NODE)	SPECIFIED BY USER BASED UPON TRAVEL DISTANCE
15. EVACUATION TIME	DELAY TIME	SPECIFIED BY USER BASED UPON TRAVEL DISTANCE AND AVAILABILITY OF TRANSPORT

TABLE A-2. MTF COMPONENT DATA USED BY MACATAK

NOTE: When accessing the MTF, the end item nomenclature and end item type are specified by the pre-processor.

1. FUNCTIONAL GROUP CODE
2. MAC LINE NUMBER
3. MAINTENANCE TASK NAME
4. REPARABLE COMPONENT
5. COMPONENT WASHOUT RATE
6. APPLICABLE SCENARIO
7. LEVEL OF REPAIR RECOMMENDED
8. MISSION ESSENTIALITY - HOT ENVIRONMENT
9. MISSION ESSENTIALITY - COLD ENVIRONMENT
10. END ITEM IMMOBILE
11. LIFT EQUIPMENT REQUIRED
12. REPARABLE BY CONTACT TEAM
13. REPARABLE WHILE ON THE END ITEM
14. MINIMUM MOS FACTOR
15. FREQUENCY OF TASK OCCURRENCE
 - a. PROBABLE VALUE (NORM)
 - b. MEASUREMENT INDEX
16. TASK TIME OR TIME TO REPAIR (PROBABLE VALUE)
17. NORMAL MANPOWER REQUIREMENTS
 - a. MOS
 - b. NUMBER
18. REPAIR PARTS
 - a. IF REPAIR PARTS ARE REQUIRED
 - b. IF A REPLACEMENT COMPONENT (DX ITEM) IS REQUIRED

and second they provide for combat damage to each recoverable and reparable end item through the random selection of shotlines.

The combat attrition data consists of the number of end items lost--that is those that are not recoverable or reparable and must be replaced from the supply system; the percent of reliability failures that are recoverable; and the number of combat damaged end items that are recoverable and reparable. In this manner the workload for both reliability failures and combat damaged items is quantifiable. This process is portrayed in Figure A-5.

The second function of the combat damage logic is to select at random a shotline for each recoverable and reparable combat damaged end item. The attack input data includes a number of shotlines for each type end item included in the model. The shotlines are extracted from existing data bases such as the combat damage (CODAM) data base. The shotlines each specify a number of maintenance actions that are contained in the MTDf and must be performed to return the operational end item to the fleet. Figure A-6 portrays this process graphically.

2) Application of Specific Effects (Attacking the System)

The MACATAK model is designed to permit both data contained in the baseline and data base to be altered to reflect the effects of the conventional, chemical and nuclear environments on the maintenance system as realistically as possible. This feature also permits the impacts of degraded supply and transportation systems to be simulated by altering appropriate supply and transportation data elements such as OSTs, availability thresholds, and DX inventories.

2. Scenario

The MACATAK model is not scenario dependent. It can be operated completely independent from a scenario with only minimum input, or it can be operated, as it was in the MEMO study, in conjunction with a scenario, wargame or another study to generate the input data required by MACATAK. The US Army Concept Analysis Agency's OMNIBUS-81 Study was used to support Phase I of the MEMO study.

a. Baseline Mode

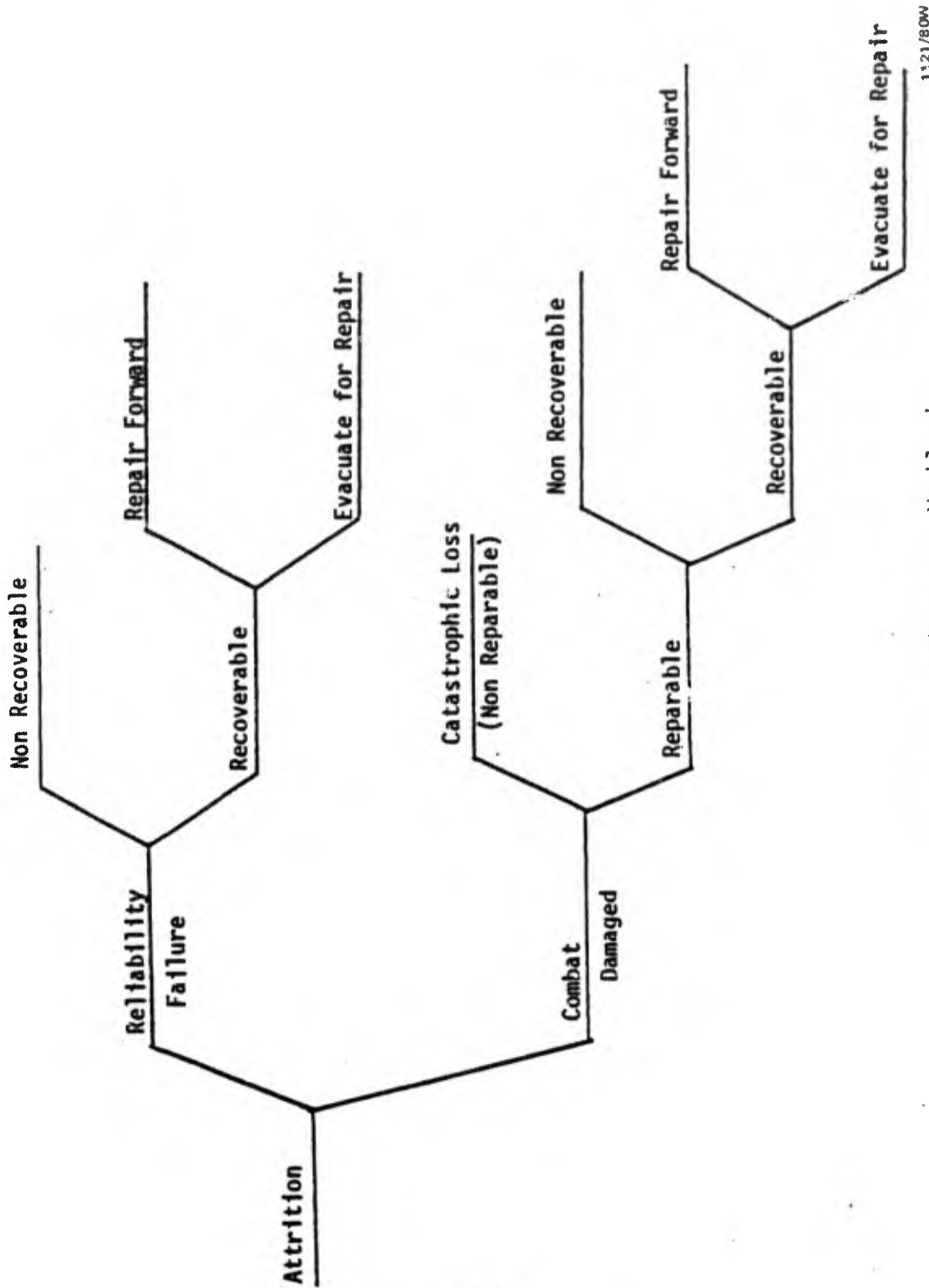

11/21/80W

Figure A-5. Maintenance workload

COMBAT DAMAGE SIMULATION

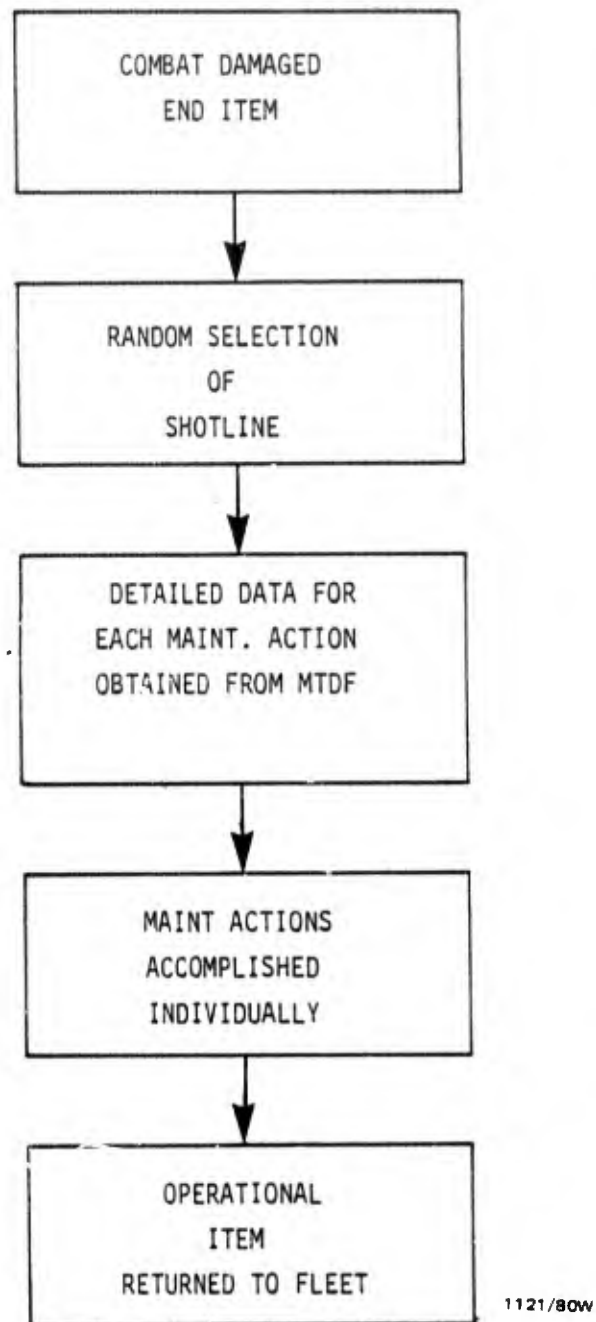

Figure A-6. Simulation of Combat Damage Using Shotlines

THE BDM CORPORATION

When operated in the baseline mode, the principal data elements required by MACATAK consist of the makeup of the maintenance system to be simulated expressed in terms of skills at each node, maintenance related equipment availability, supply policy and the types and number of equipment items to be supported at each node. The maintenance workload consists of reliability failures which occur at rates based upon the mean time between failure for each component as specified in the MTDf. Normally when operated in this mode, neither the fleet nor the maintenance system are degraded.

b. Attack Mode

When MACATAK is operated in the attack mode, combat attrition and damage inputs are required. In this mode the MACATAK model can be operated either in conjunction with a scenario or independent from a scenario. When operated in conjunction with a scenario the data provided by the events in the scenario relative to fleet and/or system degradation are used as inputs for the combat damage module. The cumulative effects of these inputs can be measured over time in terms of the number of operational end items returned to the fleet.

When the analyst desires to determine detailed effects of specific stimuli the combat damage module can be used to apply specific effects to degrade the fleet or system. In this mode the MACATAK model is operated independent of a scenario and is used to establish and analyze specific cause and effect relationships. For example the analyst may want to determine the overall impact on the productivity of the system that results from the addition or reduction of a specific MOS or a change in parts availability at given nodes. In this case the combat damage module would be used to effect the necessary stimuli and the effects on system productivity could be quantitatively determined.

c. Objectives

Due to the manner in which the MACATAK model is constructed, nearly any or all of the factors in the model can be altered. For example, the analyst can degrade personnel and equipment authorization at each node, supply availability, recovery and evacuation capabilities, etc. However,

the analyst will achieve the best results by inputting only those effects that could either realistically be experienced during a given attack or limit the number of input changes to as few as possible so that specific cause and effect relationships can be established. The more precisely the objectives can be stated, the more variables can be eliminated and subsequently the more precisely cause and effect relationships can be observed. The temptation to "model the whole world" at once should be avoided.

3. Activities Simulated

a. Supply and Transportation

Although there is no intent to simulate either the supply or transportation systems in the MACATAK model, there is a need to represent these systems in order to realistically simulate the maintenance system. The LOGATAK model can be used to evaluate the feasibility of the movements generated in MACATAK. For example, transportation for the evacuation of equipment for repair at a higher echelon, the ability of the transportation system to effect resupply of major end items and repair parts/components and the availability of repair parts/components are significant functions in simulating the maintenance of equipment. Therefore, the following provisions in the MACATAK model have been made:

- (1) Evacuation is represented by a delay time obtainable from actual experience or from other simulations such as LOGATAK. This delay time encompasses the time required to make transportation assets available and accomplish the actual evacuation from one echelon to another. This is represented in the model by a single time value for each node and as an input value in the combat damage module.
- (2) Resupply logic is represented in the model by Order Ship Time (OST) distributions relative to replacement of major end items, resupply of ASL/PLL and resupply of NSL. The OSTs relative to each category are based upon actual experience/documentation from the field or can reflect the actual OSTs being experienced by a specific unit.

THE BDM CORPORATION

- (3) Availability of repair parts/components is represented in the model by distributions based upon actual demand data and supply policy relative to demand satisfaction. In the case of determining whether an item is PLL/ASL or NSL a threshold is established based upon demand frequencies. The higher demand frequency items fall above the threshold in the PLL/ASL category. Those with lower demand frequencies are considered NSL items. PLL/ASL items are considered more often available within the division and corps supply/maintenance system than are NSL. OSTs are more likely to be shorter for PLL/ASL items than for NSL items which are obtained from excess, through cannibalization or from CONUS.
- (4) Direct exchange (DX) items are represented in the model by actual inventories due to the demands placed on the maintenance system to repair, stock and use DX items. Inventories may be initialized by pre-processor based upon direct exchange procedures contained in Section XV to Chapter 3 to AR 710-2, or actual unit inventories can be used. When DX items must be obtained from the supply system PLL/ASL logic is used.

b. Maintenance

The maintenance system is simulated by four organizational maintenance nodes, three forward direct support maintenance nodes, a rear direct support node, a general support maintenance node and a combat damage module. During the baseline run reliability failures are generated by the MTDf based upon the mean time between failure of components. The MTDf specifies the maintenance action to be performed, the level of repair, skills required, time to repair, parts/components required, whether or not a contact team can accomplish the repairs, and whether or not light equipment is required. Reliability failures are on a one-for-one basis, i.e., one failure on one end item. During wartime runs reliability failures continue plus combat damage is simulated by random selection of shotlines which identify several maintenance actions to be accomplished on each end item specified as combat damaged, recoverable and reparable.

THE BDM CORPORATION

The organizational maintenance node represents the aggregate of organizational maintenance capabilities in a brigade, in the division rear area or in a nondivisional area. Therefore, skills and lift equipment are assumed to be available. The node does, however, simulate supply and use the remainder of data elements provided by the MTD (see Figure A-7).

The forward direct support node represents the TOE maintenance unit in the brigade or other forward area. Therefore, skills are represented. DX inventories and contact teams are also represented (see Figure A-8).

The rear direct support node represents the TOE direct support maintenance units in the divisional or nondivisional support area. The rear direct support node and the forward direct support nodes simulate maintenance operations in the same level of detail (see Figure A-9).

The general support maintenance node like the organizational maintenance node assumes that all required skills are available, and gives consideration to repair parts and end item replacement supply. The purpose of the node is to represent general support level maintenance, general support contact teams, supply, and to accommodate division direct support workload overflows and diversions (see Figure A-10). In the MEMO study, increases had to be made to the numbers of repairers and lift equipment in GS TOEs. Otherwise the maintenance system would have broken down very quickly thus precluding any meaningful study of the MEMO concept.

ORGANIZATIONAL MAINTENANCE NODE

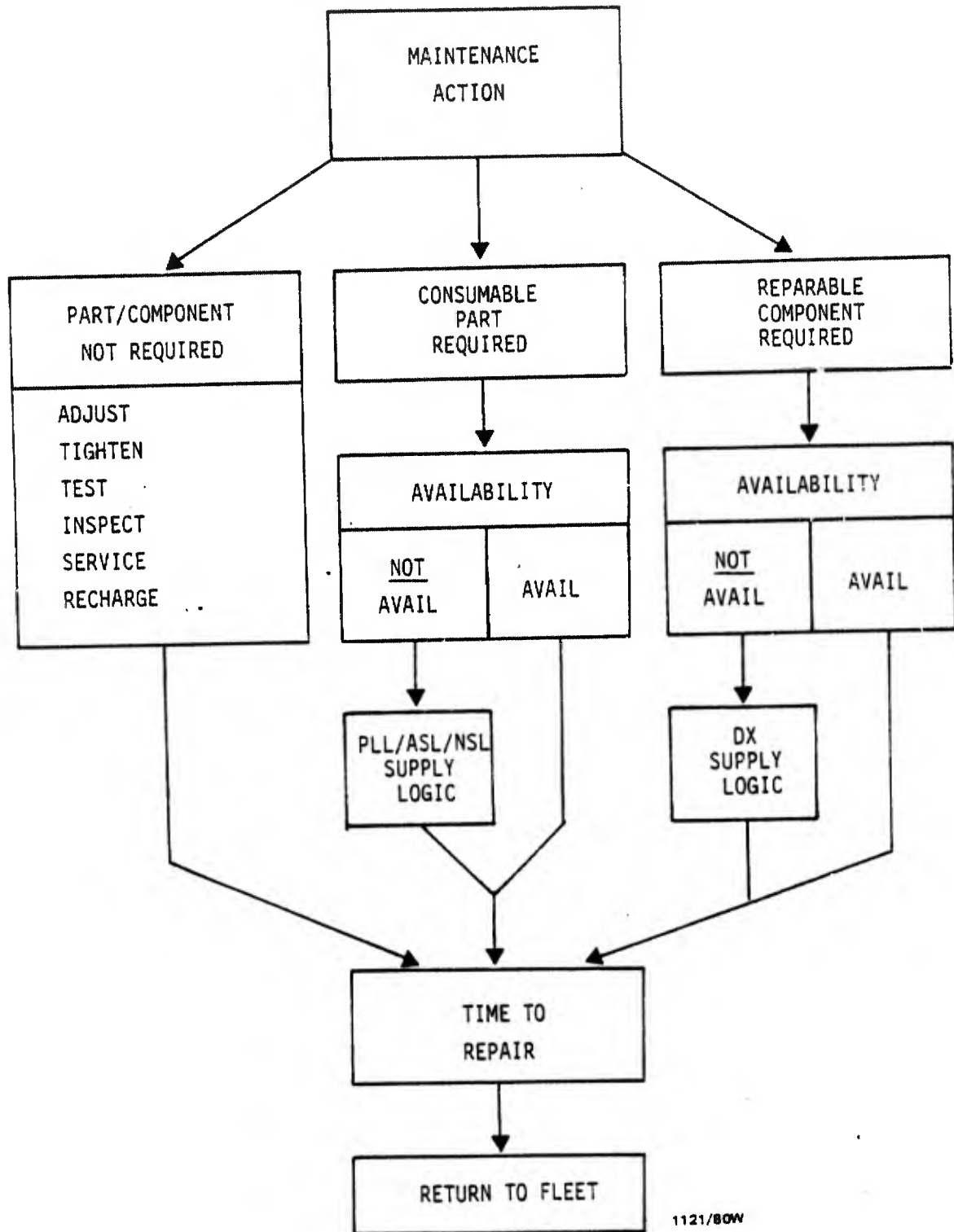

Figure A-7. Organizational Maintenance Node

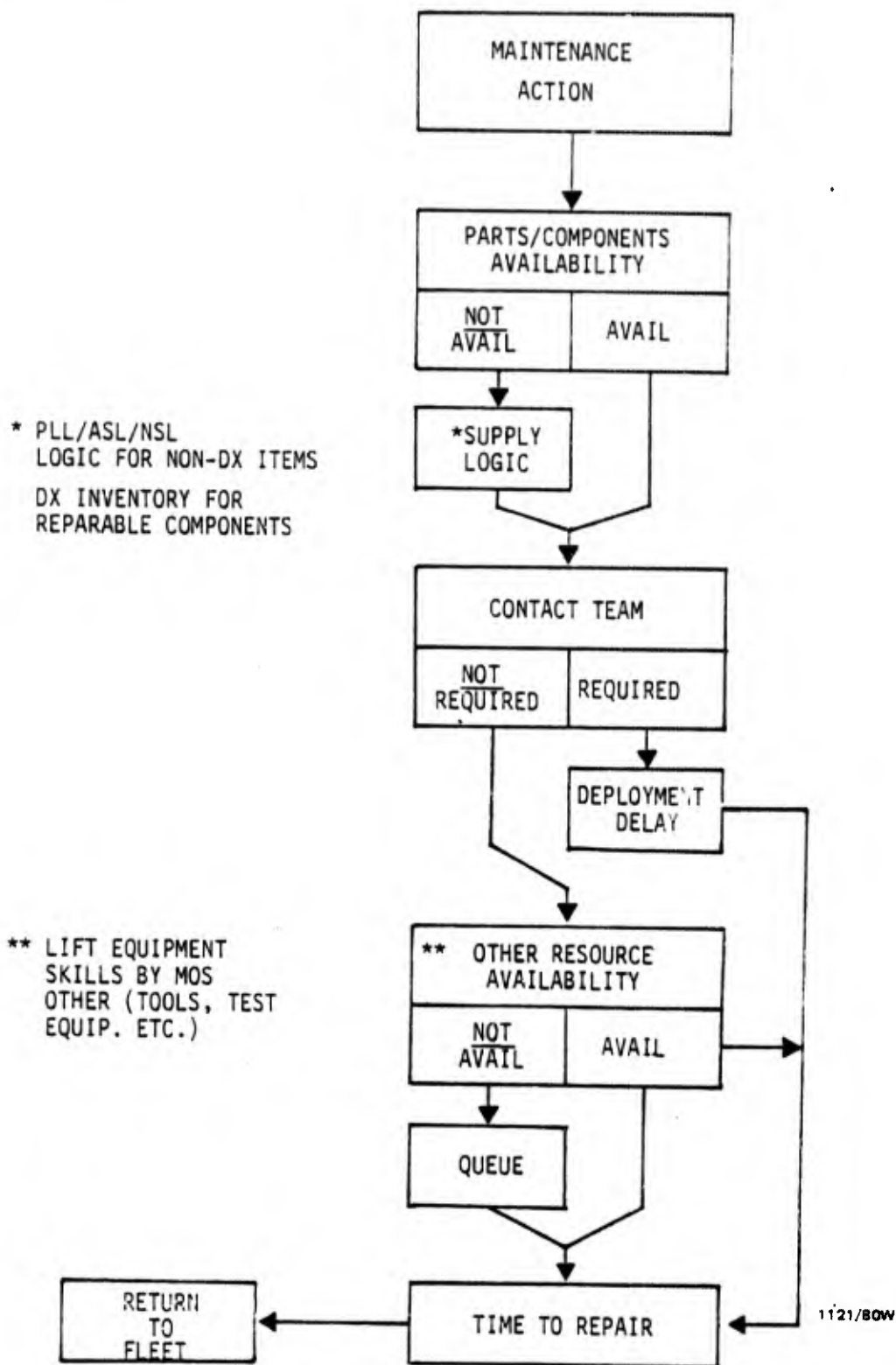

Figure A-8. Forward Direct Support Maintenance Node A-21

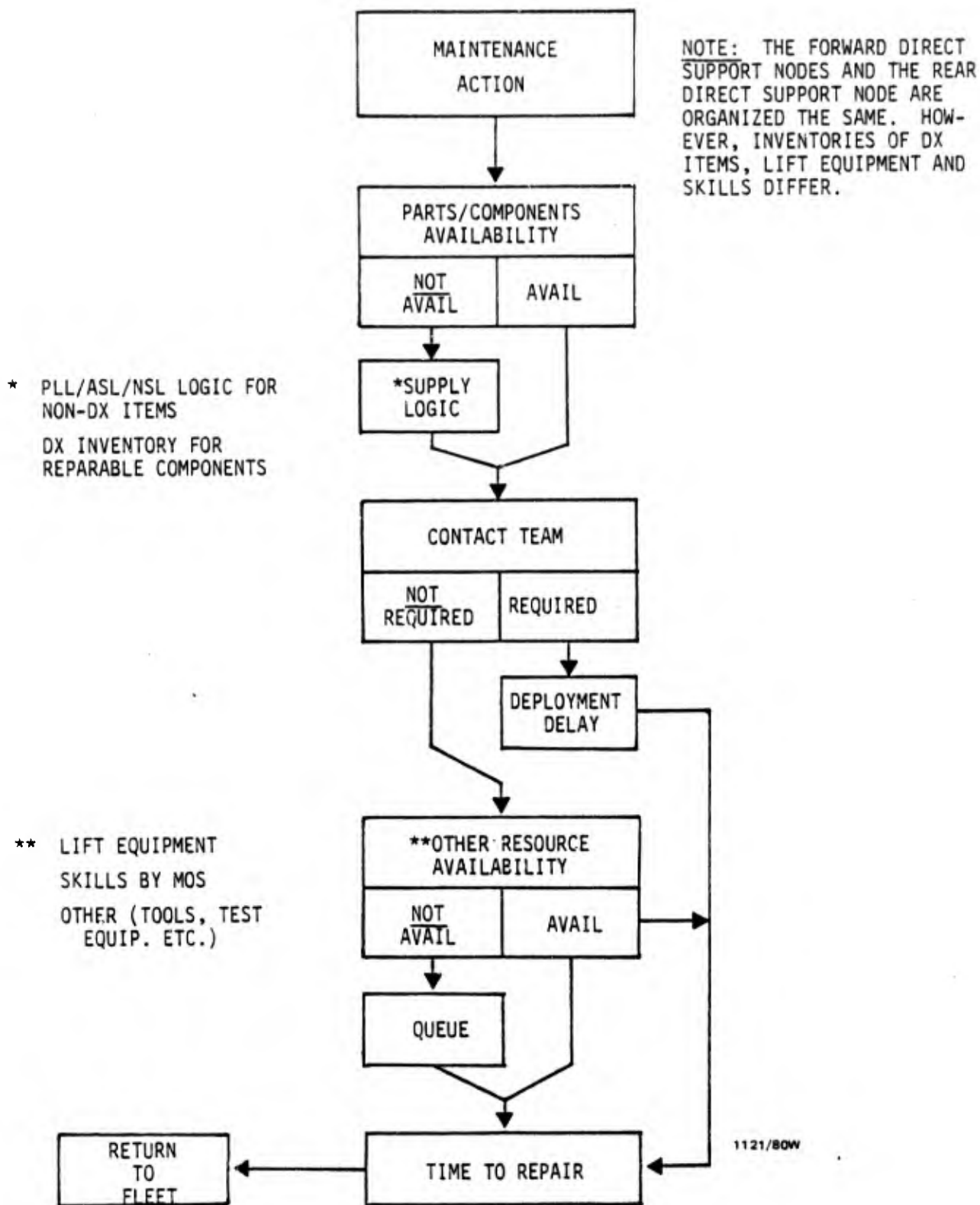

Figure A-9. Rear Direct Support Maintenance Node

GENERAL SUPPORT MAINTENANCE NODE

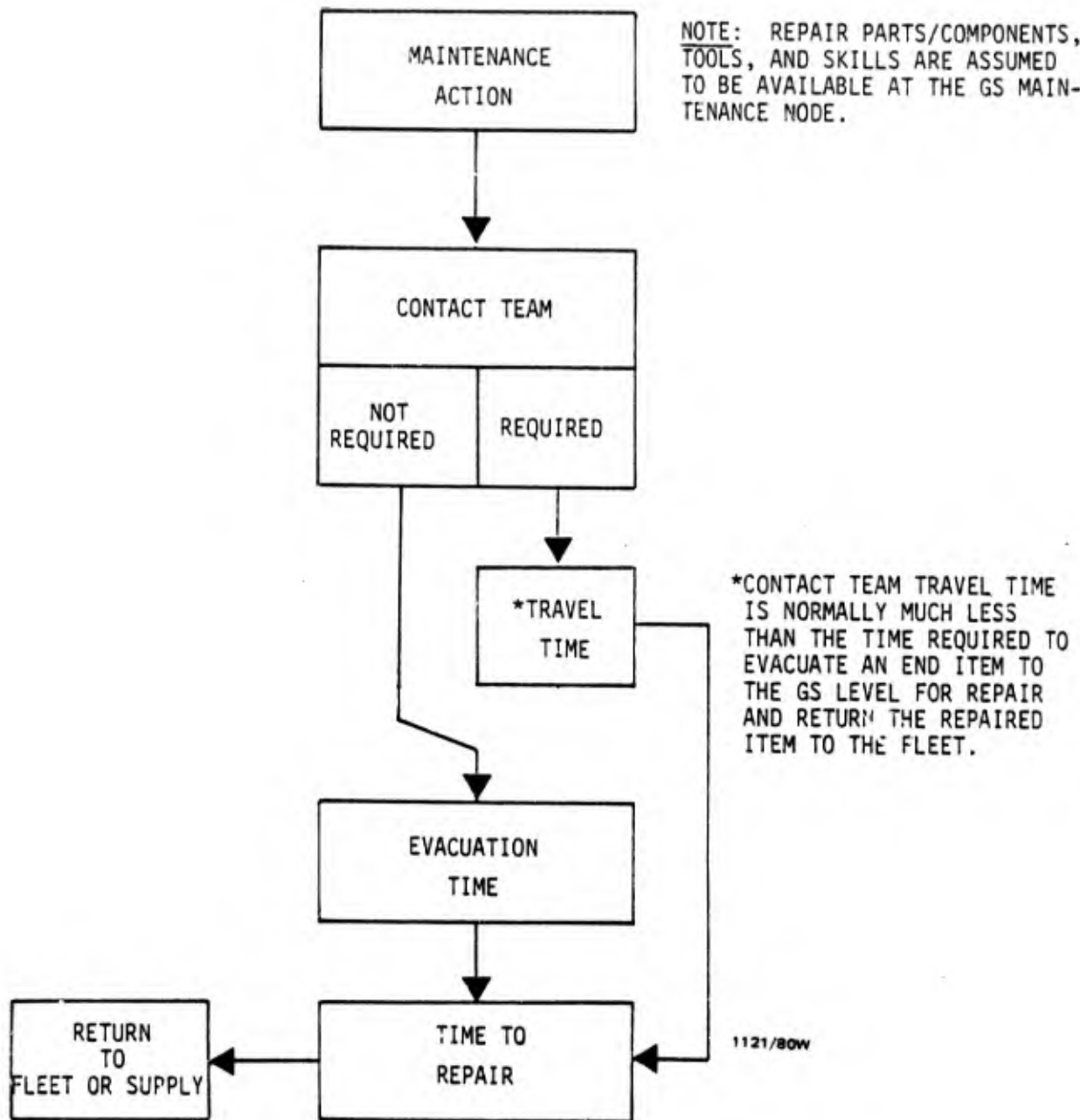

Figure A-10. General Support Maintenance Node

APPENDIX B
CONTINGENCY MAINTENANCE STANDARD
ADDITION TO AR 750-1

- 8-1 Purpose: To define the Contingency Maintenance Standard and provide implementation instructions and responsibilities.
- 8-2 Applicability: Identify the equipment or types of equipment to which the contingency maintenance standard will apply.
- 8-3 Contingency Maintenance Standard: Provide a detailed description of the contingency maintenance standard, stressing the following areas:
- (1) Incremental application of mission essential maintenance for periods not to exceed 15 to 20 days.
 - (2) Application to selected items of equipment based upon operational need.
 - (3) Application of essentiality coding to only those maintenance actions for repair of the end item.
 - (4) The use of annotated MACs which indicate mission essential, deferrable, peacetime safety and if applicable, nonessential maintenance actions for repair of the end item.
 - (5) The need to requisition repair parts and components for deferred maintenance actions as they occur.
 - (6) The need for sound maintenance management at all levels of the maintenance system, within the division as a whole and between the division and supporting general support maintenance at Corps.
- 8-4 Implementation: Provide a description of how the contingency maintenance standard is applied. Generally, the same areas should be covered in this paragraph as in paragraph 8-3. However, in this paragraph the emphasis should be on "how to" implement and who is responsible in each area.
- 8-5 Essentiality Coding of Maintenance Actions: Provide policy for essentiality coding of maintenance actions on the end item only, for

THE BDM CORPORATION

inclusion in the MACs and for determination of essentiality coding by managers for repair of reparable components. The following points should be covered:

- (1) The use of essentiality coded maintenance actions on the end items to implement the contingency maintenance standard.
- (2) The role of managers in determining essentiality of reparables required to support the implementation of the contingency maintenance standard and operational requirements. Essentiality coding of reparables must be based upon availability and demand.
- (3) The policy for including essentiality coding of repair actions on end items in the ILS process. Responsibilities of material developers and combat developers should be clearly defined.
- (4) The methodology (decision tree logic) to be used in essentiality coding of repair actions on the end items should be specified and clearly defined.